

Service Manual

Digital Camera

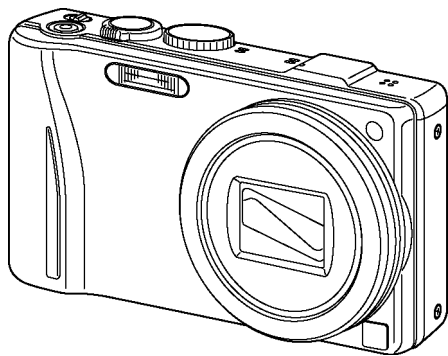

Model No. **DMC-TZ20EB**
DMC-TZ20EE
DMC-TZ20EF
DMC-TZ20EG
DMC-TZ20EP
DMC-TZ20GC
DMC-TZ20GN
DMC-TZ20SG
DMC-ZS10P
DMC-ZS10PC
DMC-ZS10PU
DMC-ZS10GD
DMC-ZS10GH
DMC-ZS10GK
DMC-ZS10GT

VOL.1

Colours

- (S).....Silver Type (except DMC-TZ20EF, ZS10PC/GD)
- (K).....Black Type
- (A).....Blue Type (only DMC-TZ20EB/EE/EG/EP/GN, ZS10P/PC)
- (R).....Red Type (except DMC-ZS10GD/GH/GT)
- (T).....Brown Type (only DMC-TZ20EE/EF/EG/EP/GC/GN, ZS10P/GK/GT)
- (N).....Gold Type (only DMC-TZ20SG, ZS10GK)

Panasonic[®]

© Panasonic Corporation 2011.
Unauthorized copying and distribution is a violation of law.

WARNING

This service information is designed for experienced repair technicians only and is not designed for use by the general public. It does not contain warnings or cautions to advise non-technical individuals of potential dangers in attempting to service a product. Products powered by electricity should be serviced or repaired only by experienced professional technicians. Any attempt to service or repair the product or products dealt with in this service information by anyone else could result in serious injury or death.

TABLE OF CONTENTS

	PAGE		PAGE
1 Safety Precautions -----	3		
1.1. General Guidelines -----	3		
1.2. Leakage Current Cold Check -----	3		
1.3. Leakage Current Hot Check (See Figure 1)-----	3		
1.4. How to Discharge the Capacitor on Flash P.C.B.-----	4		
2 Warning -----	5		
2.1. Prevention of Electrostatic Discharge (ESD) to Electrostatic Sensitive (ES) Devices-----	5		
2.2. How to Recycle the Lithium Ion Battery (U.S. Only)-----	5		
2.3. Caution for AC Cord (For EB/GC/GH/SG)-----	6		
2.4. How to Replace the Lithium Battery-----	7		
3 Service Navigation -----	9		
3.1. Introduction -----	9		
3.2. Important Notice 1:(Other than U.S.A. and Canadian Market) -----	9		
3.3. About VENUS FHD (IC6001) < Located on the Main P.C.B. >-----	9		
3.4. General Description About Lead Free Solder (PbF) -----	10		
3.5. How to Define the Model Suffix (NTSC or PAL model)-----	11		
4 Specifications -----	16		
5 Location of Controls and Components -----	18		
6 Service Mode -----	20		
6.1. Error Code Memory Function -----	20		
6.2. ICS (Indication of additional Camera Settings when picture was taken) function -----	24		
7 Troubleshooting Guide -----	26		
7.1. Checking Method of GPS failure (Except: ZS10GK) -----	26		
8 Service Fixture & Tools -----	28		
8.1. Service Fixture and Tools -----	28		
8.2. When Replacing the Main P.C.B. -----	28		
8.3. Service Position -----	29		
9 Disassembly and Assembly Instructions -----	30		
9.1. Disassembly Flow Chart-----	30		
9.2. P.C.B. Location -----	30		
9.3. Disassembly Procedure -----	31		
9.4. Lens Disassembly Procedure-----	39		
9.5. Assembly Procedure for Lens -----	43		
9.6. Removal of the C-MOS Unit-----	47		
9.7. Removal of the Zoom Motor Unit -----	47		
9.8. Removal of the Focus Motor Unit -----	48		
9.9. The Application of Grease Method -----	48		
10 Measurements and Adjustments -----	49		
10.1. Introduction -----	49		
10.2. Before Disassembling the unit-----	49		
10.3. Details of Electrical Adjustment-----	51		
10.4. After Adjustment-----	55		
11 Maintenance -----	56		
		11.1. Cleaning Lens, Viewfinder and LCD Panel -----	56

1 Safety Precautions

1.1. General Guidelines

1. IMPORTANT SAFETY NOTICE

There are special components used in this equipment which are important for safety. These parts are marked by \triangle in the Schematic Diagrams, Circuit Board Layout, Exploded Views and Replacement Parts List. It is essential that these critical parts should be replaced with manufacturer's specified parts to prevent X-RADIATION, shock fire, or other hazards. Do not modify the original design without permission of manufacturer.

2. An Isolation Transformer should always be used during the servicing of AC Adaptor whose chassis is not isolated from the AC power line. Use a transformer of adequate power rating as this protects the technician from accidents resulting in personal injury from electrical shocks. It will also protect AC Adaptor from being damaged by accidental shorting that may occur during servicing.
3. When servicing, observe the original lead dress. If a short circuit is found, replace all parts which have been overheated or damaged by the short circuit.
4. After servicing, see to it that all the protective devices such as insulation barriers, insulation papers shields are properly installed.
5. After servicing, make the following leakage current checks to prevent the customer from being exposed to shock hazards.

1.2. Leakage Current Cold Check

1. Unplug the AC cord and connect a jumper between the two prongs on the plug.
2. Measure the resistance value, with an ohmmeter, between the jumpered AC plug and each exposed metallic cabinet part on the equipment such as screwheads, connectors, control shafts, etc. When the exposed metallic part has a return path to the chassis, the reading should be between $1M\Omega$ and $5.2M\Omega$. When the exposed metal does not have a return path to the chassis, the reading must be infinity.

1.3. Leakage Current Hot Check (See Figure 1)

1. Plug the AC cord directly into the AC outlet. Do not use an isolation transformer for this check.
2. Connect a $1.5k\Omega$, 10 W resistor, in parallel with a $0.15\mu F$ capacitor, between each exposed metallic part on the set and a good earth ground, as shown in Figure 1.
3. Use an AC voltmeter, with $1 k\Omega/V$ or more sensitivity, to measure the potential across the resistor.
4. Check each exposed metallic part, and measure the voltage at each point.
5. Reverse the AC plug in the AC outlet and repeat each of the above measurements.
6. The potential at any point should not exceed 0.75 V RMS. A leakage current tester (Simpson Model 229 or equivalent) may be used to make the hot checks, leakage current must not exceed $1/2$ mA. In case a measurement is outside of the limits specified, there is a possibility of a shock hazard, and the equipment should be repaired and rechecked before it is returned to the customer.

Hot-Check Circuit

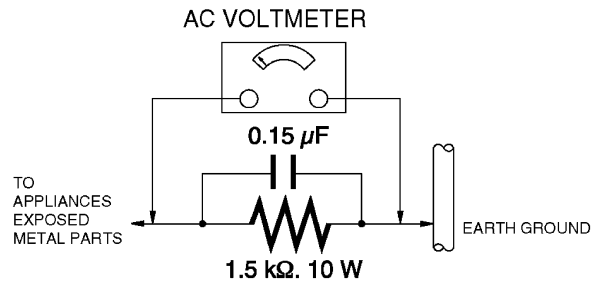

Figure 1

1.4. How to Discharge the Capacitor on Flash P.C.B.

CAUTION:

1. Be sure to discharge the capacitor on Flash P.C.B.
2. Be careful of the high voltage circuit on Flash P.C.B. when servicing.

[Discharging Procedure]

1. Refer to the disassemble procedure and remove the necessary parts/unit.
2. Install the insulation tube onto the lead part of Resistor (ERG5SJ102:1k Ω /5W).
(an equivalent type of resistor may be used.)
3. Place a resistor between both terminals of capacitor on the Flash P.C.B. for approx. 5 seconds.
4. After discharging, confirm that the capacitor voltage is lower than 10V using a voltmeter.

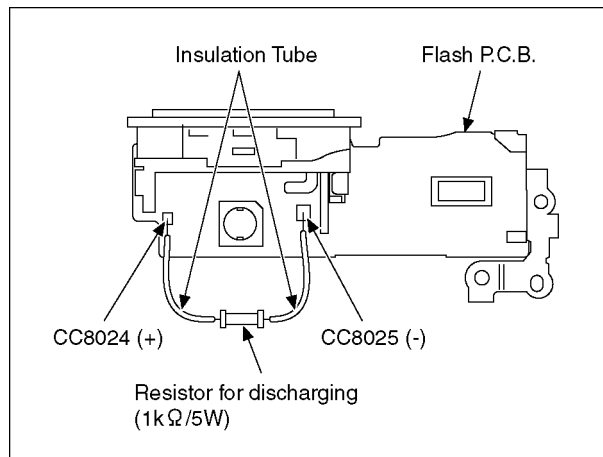

Fig. F1

2 Warning

2.1. Prevention of Electrostatic Discharge (ESD) to Electrostatic Sensitive (ES) Devices

Some semiconductor (solid state) devices can be damaged easily by static electricity. Such components commonly are called Electrostatically Sensitive (ES) Devices.

Examples of typical ES devices are C-MOS image sensor, IC (integrated circuits) and some field-effect transistors and semiconductor "chip" components.

The following techniques should be used to help reduce the incidence of component damage caused by electrostatic discharge (ESD).

1. Immediately before handling any semiconductor component or semiconductor-equipped assembly, drain off any ESD on your body by touching a known earth ground. Alternatively, obtain and wear a commercially available discharging ESD wrist strap, which should be removed for potential shock reasons prior to applying power to the unit under test.
2. After removing an electrical assembly equipped with ES devices, place the assembly on a conductive surface such as aluminum foil, to prevent electrostatic charge buildup or exposure of the assembly.
3. Use only a grounded-tip soldering iron to solder or unsolder ES devices.
4. Use only an antistatic solder removal device. Some solder removal devices not classified as **antistatic (ESD protected)** can generate electrical charge sufficient to damage ES devices.
5. Do not use freon-propelled chemicals. These can generate electrical charges sufficient to damage ES devices.
6. Do not remove a replacement ES device from its protective package until immediately before you are ready to install it. (Most replacement ES devices are packaged with leads electrically shorted together by conductive foam, aluminum foil or comparable conductive material).
7. Immediately before removing the protective material from the leads of a replacement ES device, touch the protective material to the chassis or circuit assembly into which the device will be installed.

CAUTION:

Be sure no power is applied to the chassis or circuit, and observe all other safety precautions.

8. Minimize bodily motions when handling unpackaged replacement ES devices. (Otherwise harmless motion such as the brushing together of your clothes fabric or the lifting of your foot from a carpeted floor can generate static electricity (ESD) sufficient to damage an ES device).

2.2. How to Recycle the Lithium Ion Battery (U.S. Only)

ENGLISH



A lithium ion/polymer battery that is recyclable powers the product you have purchased. Please call 1-800-8-BATTERY for information on how to recycle this battery.

FRANÇAIS



L'appareil que vous vous êtes procuré est alimenté par une batterie au lithium-ion/polymère recyclable. Pour des renseignements sur le recyclage de la batterie, veuillez composer le 1-800-8-BATTERY.

2.3. Caution for AC Cord (For EB/GC/GH/SG)

2.3.1. Information for Your Safety

IMPORTANT

Your attention is drawn to the fact that recording of pre-recorded tapes or discs or other published or broadcast material may infringe copyright laws.

WARNING

To reduce the risk of fire or shock hazard, do not expose this equipment to rain or moisture.

CAUTION

To reduce the risk of fire or shock hazard and annoying interference, use the recommended accessories only.

FOR YOUR SAFETY

DO NOT REMOVE THE OUTER COVER

To prevent electric shock, do not remove the cover. No user serviceable parts inside. Refer servicing to qualified service personnel.

2.3.2. Caution for AC Mains Lead

For your safety, please read the following text carefully.

This appliance is supplied with a moulded three-pin mains plug for your safety and convenience.

A 5-ampere fuse is fitted in this plug.

Should the fuse need to be replaced please ensure that the replacement fuse has a rating of 5 amperes and it is approved by ASTA or BSI to BS1362

Check for the ASRA mark or the BSI mark on the body of the fuse.



If the plug contains a removable fuse cover you must ensure that it is refitted when the fuse is replaced.

If you lose the fuse cover, the plug must not be used until a replacement cover is obtained.

A replacement fuse cover can be purchased from your local Panasonic Dealer.

If the fitted moulded plug is unsuitable for the socket outlet in your home then the fuse should be removed and the plug cut off and disposed of safely.

There is a danger of severe electrical shock if the cut off plug is inserted into any 13-ampere socket.

If a new plug is to be fitted please observe the wiring code as shown below.

If in any doubt, please consult a qualified electrician.

2.3.2.1. Important

The wires in this mains lead are coloured in accordance with the following code:

Blue	Neutral
Brown	Live

As the colours of the wires in the mains lead of this appliance may not correspond with the coloured markings identifying the terminals in your plug, proceed as follows:

The wire which is coloured BLUE must be connected to the terminal in the plug which is marked with the letter N or coloured BLACK.

The wire which is coloured BROWN must be connected to the terminal in the plug which is marked with the letter L or coloured RED.

Under no circumstances should either of these wires be connected to the earth terminal of the three pin plug, marked with the letter E or the Earth Symbol.

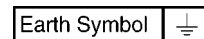

2.3.2.2. Before Use

remove the Connector Cover as follows.

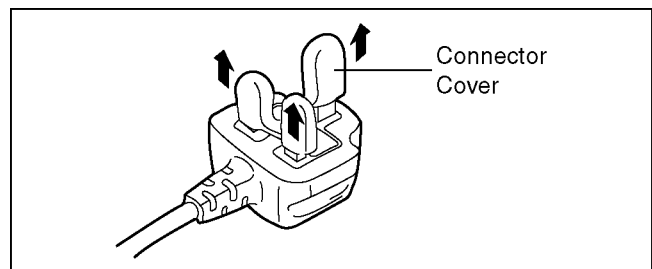

2.3.2.3. How to Replace the Fuse

1. Remove the Fuse Cover with a screwdriver.

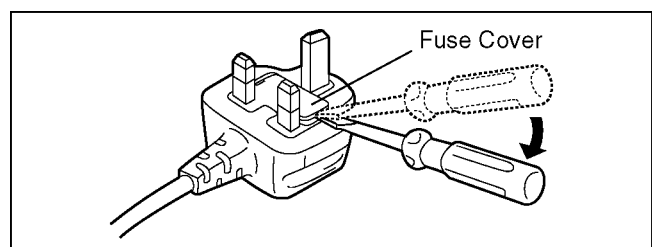

2. Replace the fuse and attach the Fuse cover.

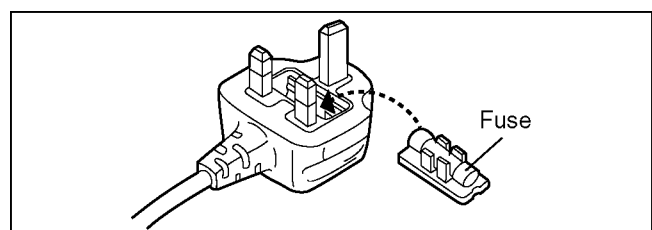

2.4. How to Replace the Lithium Battery

2.4.1. Replacement Procedure

1. Remove the SD Card P.C.B. (Refer to Disassembly Procedures.)
2. Remove the Lithium battery (Ref. No. **ZB9901** at foil side of SD Card P.C.B.) and then replace it into new one.

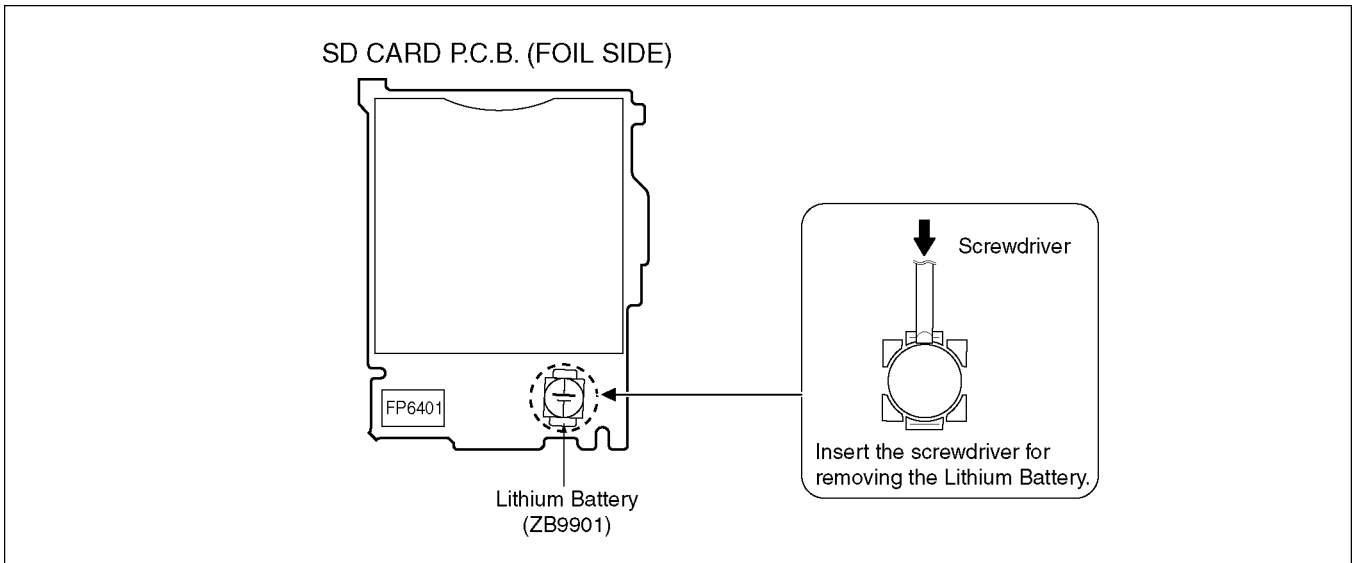

CAUTION

Danger of explosion if battery is incorrectly replaced.
Replace only with the same or equivalent type.

CAUTION

The battery used in this device may present a risk of fire or chemical burn if mistreated.
Do not recharge, disassemble, heat above 100°C (212°F), or incinerate.
Replace battery with Panasonic part number ML-421S/DN only.
Use of another battery may present a risk of fire or explosion.
Dispose of used battery promptly.
Keep away from children.
Do not disassemble and do not dispose of in fire.

Note:

The lithium battery is a critical component.

(Type No.: ML-421S/DN **Manufactured by Energy Company, Panasonic Corporation.**)

It must never be subjected to excessive heat or discharge.

It must therefore only be fitted in equipment designed specifically for its use.

Replacement batteries must be of the same type and manufacture.

They must be fitted in the same manner and location as the original battery, with the correct polarity contacts observed.

Do not attempt to re-charge the old battery or re-use it for any other purpose.

It should be disposed of in waste products destined for burial rather than incineration.

(For English)

CAUTION

Danger of explosion if battery is incorrectly replaced.
Replace only with the same or equivalent type recommended by the manufacturer.
Dispose of used batteries according to the manufacturer's instructions.

(For German)

ACHTUNG

Explosionsgefahr bei falschem Anbringen der Batterie. Ersetzen Sie nur mit einem äquivalentem vom Hersteller empfohlenem Typ.
Behandeln Sie gebrauchte Batterien nach den Anweisungen des Herstellers.

(For French)

MISE EN GARDE

Une batterie de remplacement inappropriée peut exploser. Ne remplacez qu'avec une batterie identique ou d'un type recommandé par le fabricant. L'élimination des batteries usées doit être faite conformément aux instructions du fabricant.

Note:

Above caution is applicable for a battery pack which is for DMC-TZ20/ZS10 series, as well.

3 Service Navigation

3.1. Introduction

This service manual contains technical information, which will allow service personnel's to understand and service this model. Please place orders using the parts list and not the drawing reference numbers. If the circuit is changed or modified, the information will be followed by service manual to be controlled with original service manual.

3.2. Important Notice 1:(Other than U.S.A. and Canadian Market)

1. The service manual does not contain the following information because of the issue servicing to component level without necessary equipment/facilities.
 - a. Schematic diagram, Block Diagram and PCB layout of MAIN P.C.B.
 - b. Parts list for individual parts for MAIN P.C.B.When a part replacement is required for repairing MAIN P.C.B., replace as an assembled parts. (MAIN P.C.B.)

3.3. About VENUS FHD (IC6001) < Located on the Main P.C.B. >

- The VENUS FHD (IC6001) consists of two IC chips, which are fixed together with solder. (It is so called, "Package On Package" type of IC.)

Caution:

- During servicing, do not press down hard on the surface of IC6001.

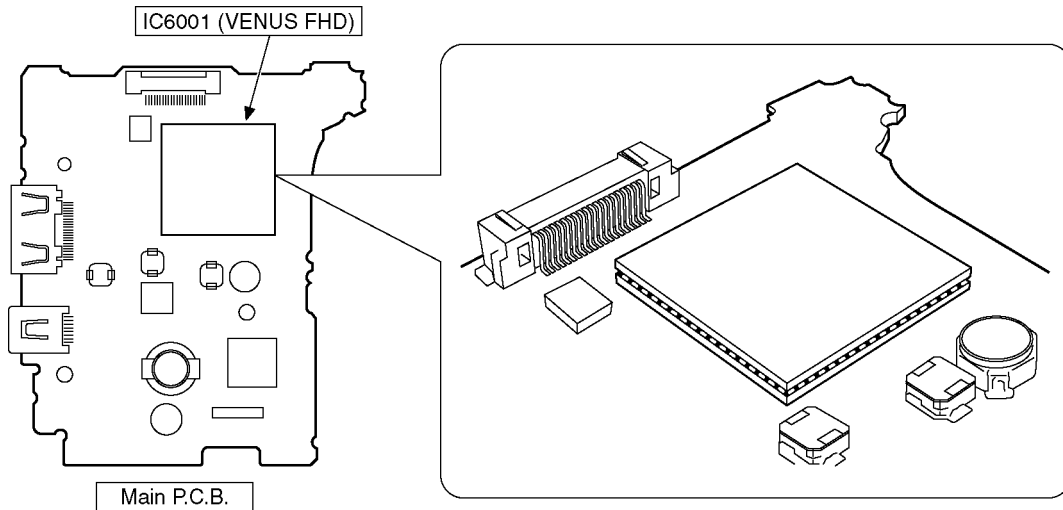

3.4. General Description About Lead Free Solder (PbF)

The lead free solder has been used in the mounting process of all electrical components on the printed circuit boards used for this equipment in considering the globally environmental conservation.

The normal solder is the alloy of tin (Sn) and lead (Pb). On the other hand, the lead free solder is the alloy mainly consists of tin (Sn), silver (Ag) and Copper (Cu), and the melting point of the lead free solder is higher approx.30 °C (86 °F) more than that of the normal solder.

Definition of PCB Lead Free Solder being used

The letter of PbF is printed either foil side or components side on the P.C.B. using the lead free solder. (See right figure)

PbF

Service caution for repair work using Lead Free Solder (PbF)

- The lead free solder has to be used when repairing the equipment for which the lead free solder is used.
- (Definition: The letter of **PbF** is printed on the P.C.B. using the lead free solder.)
- To put lead free solder, it should be well molten and mixed with the original lead free solder.
- Remove the remaining lead free solder on the P.C.B. cleanly for soldering of the new IC.
- Since the melting point of the lead free solder is higher than that of the normal lead solder, it takes the longer time to melt the lead free solder.
- Use the soldering iron (more than 70W) equipped with the temperature control after setting the temperature at 350±30 degrees C (662±86 °F).

Recommended Lead Free Solder (Service Parts Route.)

- The following 3 types of lead free solder are available through the service parts route.
 - RFKZ03D01KS----- (0.3mm 100g Reel)
 - RFKZ06D01KS----- (0.6mm 100g Reel)
 - RFKZ10D01KS----- (1.0mm 100g Reel)

Note:

* Ingredient: tin (Sn) 96.5%, silver (Ag) 3.0%, Copper (Cu) 0.5%, Cobalt (Co) / Germanium (Ge) 0.1 to 0.3%

3.5. How to Define the Model Suffix (NTSC or PAL model)









There are nine kinds of DMC-TZ20/ZS10, regardless of the colours.

- a) DMC-TZ20 (Japan domestic model.) /SG
- b) DMC-ZS10P/PC
- c) DMC-TZ20EB/EF/EG/EP
- d) DMC-TZ20EE
- e) DMC-ZS10GD
- f) DMC-ZS10GT
- g) DMC-TZ20GN
- h) DMC-ZS10GK
- i) DMC-TZ20GC, ZS10GH/PU

What is the difference is that the "INITIAL SETTINGS" data which is stored in Flash ROM mounted on Main P.C.B.

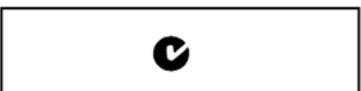
3.5.1. Defining methods

To define the model suffix to be serviced, refer to the nameplate which is putted on the bottom side of the Unit.

<p>a) DMC-TZ20 (Japan domestic model) /SG The nameplate for this model shows the following Safety registration mark.</p>	 <p style="text-align: center;">Safety registration mark</p>
	
<p>b) DMC-ZS10P/PC The nameplate for these models show the following Safety registration mark.</p>	
	
<p>c) DMC-TZ20EB/EF/EG/EP The nameplate for these models show the following Safety registration mark.</p>	
	
<p>d) DMC-TZ20EE The nameplate for this model show the following Safety registration mark.</p>	<p>g) DMC-TZ20GN The nameplate for these models show the following Safety registration mark.</p>
	
<p>e) DMC-ZS10GD The nameplate for this model show the following Safety registration mark.</p>	<p>h) DMC-ZS10GK The nameplate for these models show the following Safety registration mark.</p>
	
<p>f) DMC-ZS10GT The nameplate for this model show the following Safety registration mark.</p>	<p>i) DMC-TZ20GC, DMC-ZS10GH/PU The nameplate for these models do not show any above safety registration mark.</p>
	

Note:
After replacing the MAIN P.C.B., be sure to achieve adjustment.
The Maintenance software (DIAS) is available at "software download" on the "Support Information from NWBG/VDBG-AVC"
web-site in "TSN system".

3.5.2. INITIAL SETTINGS:

After replacing the MAIN P.C.B., make sure to perform the initial settings after achieving the adjustment by ordering the following procedure in accordance with model suffix of the unit.

1. IMPORTANT NOTICE:

Before proceeding Initial settings, be sure to read the following CAUTIONS.

CAUTION 1:(INITIAL SETTINGS)

---AFTER REPLACING THE MAIN P.C.B. ---

[Other than "EG, EF, EB, EP and GK" models : (VEP56124A is used as a Main P.C.B.)]

*.The model suffix can be chosen **JUST ONE TIME** .

(Effective model suffix : DMC-TZ20 " EE/GC/GN/SG and NONE(JAPAN)"
DMC-ZS10 " GD/GH/GT/P/PC and PU")

*.Once one of the model suffix has been chosen, the model suffix lists will not be displayed, thus, it can not be changed.

[Only for "EG, EF, EB and EP" models : (VEP56124B is used as a Main P.C.B.)]

*.From the beginning, only "EG, EF, EB, and EP" are displayed as a model suffix lists, and these are displayed from the second times as well.

[Only for "GK" model : (VEP56124C is used as a Main P.C.B.)]

*.From the beginning, only "GK" is displayed as a model suffix list, and this is displayed from the second times as well.

CAUTION 2:(Stored picture image data in the unit)

This unit employs "Built-in Memory" for picture image data recording.(Approx.18MB)
After proceeding "INITIAL SETTINGS", the picture image data stored in the unit is erased.

2. PROCEDURES:

- Precautions: Read the above "CAUTION 1" and "CAUTION 2", carefully.
- Preparation:

1. Attach the Battery or AC Adaptor with a DC coupler to the unit.
2. Set the mode dial to the PROGRAM AE mode.

Note: If the mode dial position is other than PROGRAM AE mode, it does not display the initial settings menu.

- **Step 1. The temporary cancellation of "INITIAL SETTINGS":**

Set the REC/PLAYBACK selector switch to "REC (Camera mark)".

While keep pressing "UP of Cursor button" and MOTION PICTURE button simultaneously, turn the Power on.

- **Step 2. The cancellation of "INITIAL SETTINGS":**

Set the REC/PLAYBACK selector switch to "PLAYBACK".

Press "UP of Cursor button" and MOTION PICTURE button simultaneously, then turn the Power off.

- **Step 3. Turn the Power on:**

Set the REC/PLAYBACK selector switch to "REC (Camera mark)", and then turn the Power on.

• **Step 4. Display the "INITIAL SETTINGS" menu:**

Note: If the unit is other than PROGRAM AE mode, it does not display the initial settings menu. While keep pressing MENU/SET and "RIGHT of Cursor button" simultaneously, turn the Power off. The "INITIAL SETTINGS" menu is displayed.

There are two kinds of "INITIAL SETTINGS" menu form as follows:

[CASE 1. After replacing MAIN P.C.B.]

There are three kinds of menu form as follows:

[Except for "EG, EF, EB, EP and GK" models : (VEP56124A is used as a Main P.C.B.)]

When MAIN P.C.B. has just been replaced, all of the model suffix are displayed as follows. (Four pages in total)

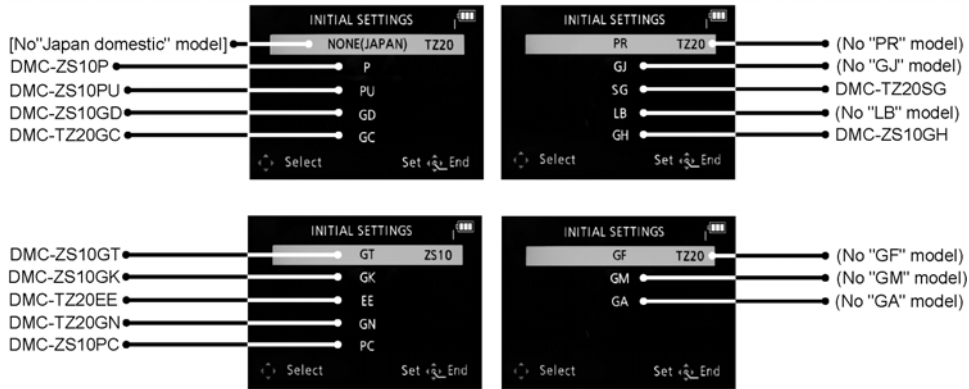

[Only for "EG, EF, EB and EP" models : (VEP56124B is used as a Main P.C.B.)]

When MAIN P.C.B. has just been replaced, the following model suffix are displayed as follows. (Two pages in total)



[Only for "GK" model : (VEP56124C is used as a Main P.C.B.)]

When MAIN P.C.B. has just been replaced, the only "GK" is displayed as follow.



[CASE 2. Other than "After replacing MAIN P.C.B."]

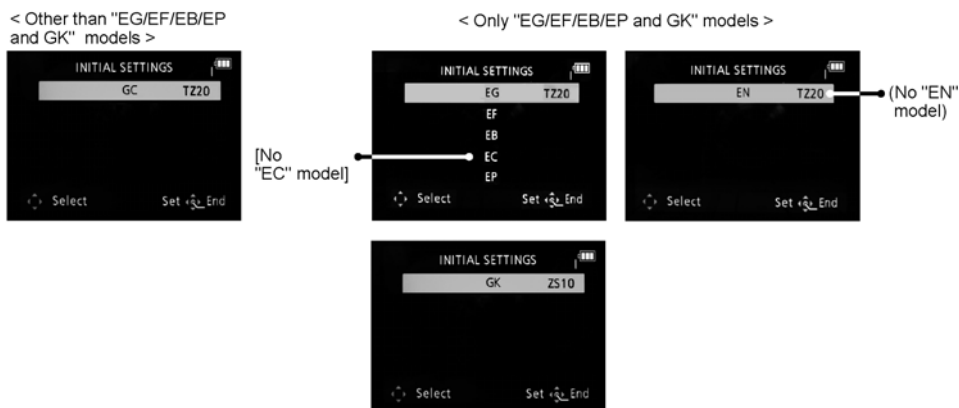

• **Step 5. Chose the model suffix in "INITIAL SETTINGS": (Refer to "CAUTION 1")**

[Caution: After replacing MAIN P.C.B.]

(Especially, other than "EG, EF, EB and EP" models : (VEP56101B is used as a Main P.C.B.)).

The model suffix can be chosen, JUST ONE TIME.

Once one of the model suffix have been chosen, the model suffix lists will not be displayed, thus, it can be changed.

Therefore, select the area carefully.

Select the area with pressing "UP / DOWN of Cursor buttons".

• **Step 6. Set the model suffix at "INITIAL SETTINGS":**

Press the "RIGHT" of Cursor buttons".

The only set area is displayed. Press the "RIGHT" of Cursor buttons" after confirmation.

(The unit is powered off automatically.)

• **Step 7. CONFIRMATION:**

Confirm the display of "PLEASE SET THE CLOCK" in concerned language when the unit is turned on again.

When the unit is connected to PC with USB cable, it is detected as removable media.

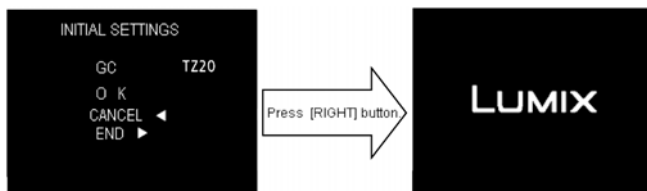

1) As for your reference, major default setting condition is as shown in the following table.

Default setting (After "INITIAL SETTINGS")

	MODEL	VIDEO OUTPUT	LANGUAGE	DATE	REMARKS
a)	DMC-TZ20 (Japan domestic model)	NTSC	Japanese	Year/Month/Date	
b)	DMC-TZ20EB	PAL	English	Date/Month/Year	
c)	DMC-TZ20EE	PAL	Russian	Date/Month/Year	
d)	DMC-TZ20EF	PAL	French	Date/Month/Year	
e)	DMC-TZ20EG	PAL	English	Date/Month/Year	
f)	DMC-TZ20EP	PAL	English	Date/Month/Year	
g)	DMC-TZ20GC	PAL	English	Date/Month/Year	
h)	DMC-TZ20GN	PAL	English	Date/Month/Year	
i)	DMC-TZ20SG	PAL	English	Date/Month/Year	
j)	DMC-ZS10GD	NTSC	Korean	Year/Month/Date	
k)	DMC-ZS10GH	PAL	English	Date/Month/Year	
l)	DMC-ZS10GK	PAL	Chinese (simplified)	Year/Month/Date	No Underwater mode.
m)	DMC-ZS10GT	NTSC	Chinese (Traditional)	Year/Month/Date	
n)	DMC-ZS10P	NTSC	English	Month/Date/Year	
o)	DMC-ZS10PC	NTSC	English	Month/Date/Year	
p)	DMC-ZS10PU	NTSC	Spanish	Month/Date/Year	

4 Specifications

Digital Camera: Information for your safety

Power Source	DC 5.1 V
Power Consumption	When recording: 1.4 W When playing back: 0.9 W
Camera effective pixels	14,100,000 pixels
Image sensor	1/2.33" MOS sensor, total pixel number 15,100,000 pixels Primary color filter
Lens	Optical 16 x zoom f=4.3 mm to 68.8 mm (35 mm film camera equivalent: 24 mm to 384 mm)/ F3.3 (Max. W) to F5.9 (Max. T)
Digital Zoom	Max. 4 x
Extended optical zoom	Max. 33.8 x (When the picture size is set to 3 million pixels [3M] or less.)
Focus range	
P/A/S/M	50 cm (1.64 feet) (Wide)/2 m (6.57 feet) (Tele) to ∞
Macro/ Intelligent Auto/ Motion picture	3 cm (0.10 feet) (Wide)/1 m (3.28 feet) (Tele) to ∞ (7 x to 11 x is 2 m (6.57 feet) to ∞)
Scene Mode	There may be difference in above settings.
Shutter system	Electronic shutter + Mechanical shutter
Burst recording	Burst speed (Burst number/maximum recordable pixels)
For mechanical shutter	Approx. 2 frames/sec (Max. 100 frames/14 M), Approx. 5 frames/sec (Max. 100 frames/14 M), Approx. 10 frames/sec (Max. 15 frames/14 M)
For electronic shutter	40 frames/sec (Max. 50 frames/5 M), 60 frames/sec (Max. 60 frames/3.5 M)
During motion picture recording	Approx. 2 frames/sec (Max. 40 frames/3.5 M), Approx. 5 frames/sec (Max. 40 frames/3.5 M), Approx. 10 frames/sec (Max. 40 frames/3.5 M)

Minimum Illumination	Approx. 14 lx (when i-Low light is used, the shutter speed is 1/60th of a second)
Shutter speed	60 to 1/4000 th [Starry Sky] Mode: 15 seconds, 30 seconds, 60 seconds
Exposure (AE)	Program AE (P)/Aperture-priority AE (A)/ Shutter-priority AE (S)/Manual exposure (M) Exposure Compensation (1/3 EV Step, -2 EV to +2 EV)
Metering Mode	Multiple/Center weighted/Spot
LCD monitor	3.0" TFT LCD (4:3) (Approx. 460,800 dots) (field of view ratio about 100 %)/Touch panel
Flash	Flash range: (ISO AUTO) Approx. 60 cm (1.97 feet) to 5.0 m (16.4 feet) (Wide)
Microphone	Stereo
Speaker	Monaural
Recording media	Built-in Memory (Approx. 18 MB)/SD Memory Card/ SDHC Memory Card/SDXC Memory Card
Recording file format	
Still picture	JPEG (based on Design rule for Camera File system, based on Exif 2.3 standard/DPOF corresponding)/MPO
Motion pictures	AVCHD/QuickTime Motion JPEG
Interface	
Digital	USB 2.0 (High Speed)
Analog video	NTSC Composite
Audio	Audio line output (Monaural)
Terminal	HDMI: MiniHDMI TypeC AV OUT/DIGITAL: Dedicated jack (8 pin)
Dimensions	Approx. 104.9 mm (W) x 57.6 mm (H) x 33.4 mm (D) [4.13" (W) x 2.27" (H) x 1.31" (D)] (excluding the projection part)

Mass	With card and battery: Approx. 219 g (0.482 lb) Excluding card and battery: Approx. 197 g (0.434 lb)
Operating temperature	0 °C to 40 °C (32 °F to 104 °F)
Operating humidity	10 %RH to 80 %RH
GPS	Reception frequency: 1575.42 MHz (C/A code) Geographical coordinate system: WGS84
Language select	[ENGLISH]/[ESPAÑOL]

Battery charger
(Panasonic DE-A65B): Information for your safety

Input	110 V to 240 V ~ 50/60Hz, 0.2 A
Output	4.2 V === 0.65 A

Equipment mobility: Movable
Battery Pack (lithium-ion)
(Panasonic DMW-BCG10PP): Information for your safety

Voltage/capacity	3.6 V/895 mAh
-------------------------	---------------

Note:

*Above specification is for DMC-ZS10P. Some of the specification may differ depends on model suffix.

[1] Only for "EB/EF/EG/EP" models:

1). [Interface Digital:]

- Data from the PC can not be written to the camera using the USB connection cable.

[2] Others:

1). [Analog video/audio:]

NTSC -----(Only "P/PC/PU/GT/GD" models)

NTSC/PAL Composite (Switched by menu) -----(Except "P/PC/PU/GT/GD" models)

2). [GPS:]

- DMC-ZS10GK does not equipped with GPS function.

5 Location of Controls and Components

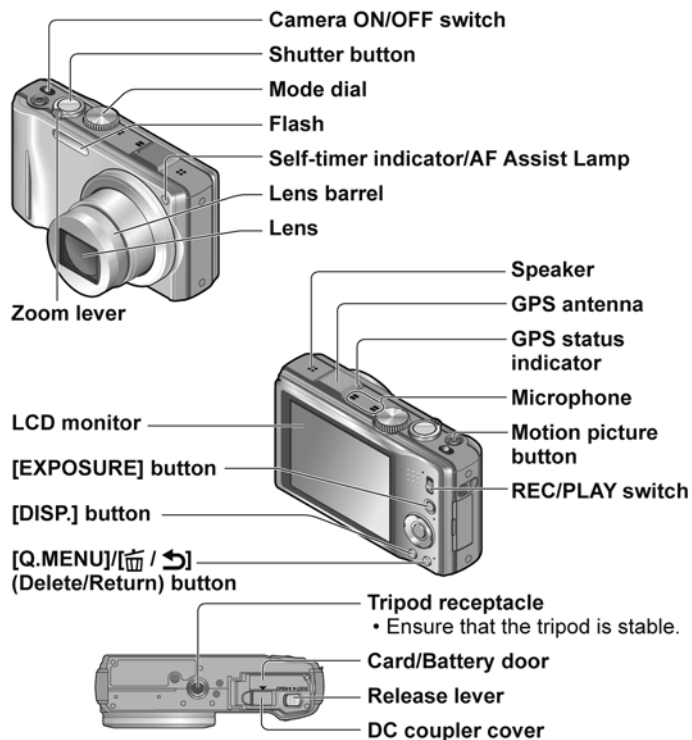

● The illustrations and screens in this manual may differ from the actual product.

Cursor button

[MENU/SET]
 (menu display/set/finish)

Up cursor button (▲)
 • Exposure Compensation, Auto Bracket etc.

Left cursor button (◀)
 • Self-timer

Right cursor button (▶)
 • Flash

Down cursor button (▼)
 • Macro Mode etc.

● In this manual, the button that is used is indicated by ▲ ▼ ▶ ◀.

Hand strap eyelet

①
②

We recommend using the supplied hand strap to avoid dropping the camera.

HDMI socket

[AV OUT/DIGITAL] socket

Mode dial

iA	[Intelligent Auto] Mode Take pictures with automatic settings.
P	[Program AE] Mode The subjects are recorded using your own settings.
A	[Aperture-Priority] Mode The shutter speed is automatically determined by the aperture value you set.
S	[Shutter-Priority] Mode The aperture value is automatically determined by the shutter speed you set.
M	[Manual Exposure] Mode The exposure is adjusted by the aperture value and the shutter speed which are manually adjusted.
CUST	[Custom] Mode Use this mode to take pictures with previously registered setting.
3D	[3D Photo Mode] Record 3D still pictures.
SCN	[Scene Mode] Take pictures according to the scene.
MS1	[My Scene Mode]
MS2	Take pictures in frequently-used Scene Modes.

6 Service Mode

6.1. Error Code Memory Function

1. General description

This unit is equipped with history of error code memory function, and can be memorized 16 error codes in sequence from the latest. When the error is occurred more than 16, the oldest error is overwritten in sequence.

The error code is not memorized when the power supply is shut down forcibly (i.e., when the unit is powered on by the battery, the battery is pulled out) The error code is memorized to FLASH ROM when the unit has just before powered off.

2. How to display

The error code can be displayed by ordering the following procedure:

• Preparation:

1. Attach the Battery or AC Adaptor with a DC coupler to the unit.
2. Set the mode dial to the PROGRAM AE mode.

Note:

*Since this unit has built-in memory, it can be performed without inserting SD memory card.

• Step 1. The temporary cancellation of "INITIAL SETTINGS":

Set the REC/PLAYBACK selector switch to "REC (Camera mark)".

While keep pressing "UP of Cursor button" and "MOTION PICTURE button simultaneously, turn the Power on.

• Step 2. Execute the error code display mode:

Press the "LEFT of Cursor button", MENU/SET button and MOTION PICTURE button simultaneously.

The display is changed as shown below when the above buttons are pressed simultaneously.

Normal display → Error code display → Operation history display → Normal display →

Example of Error Code Display

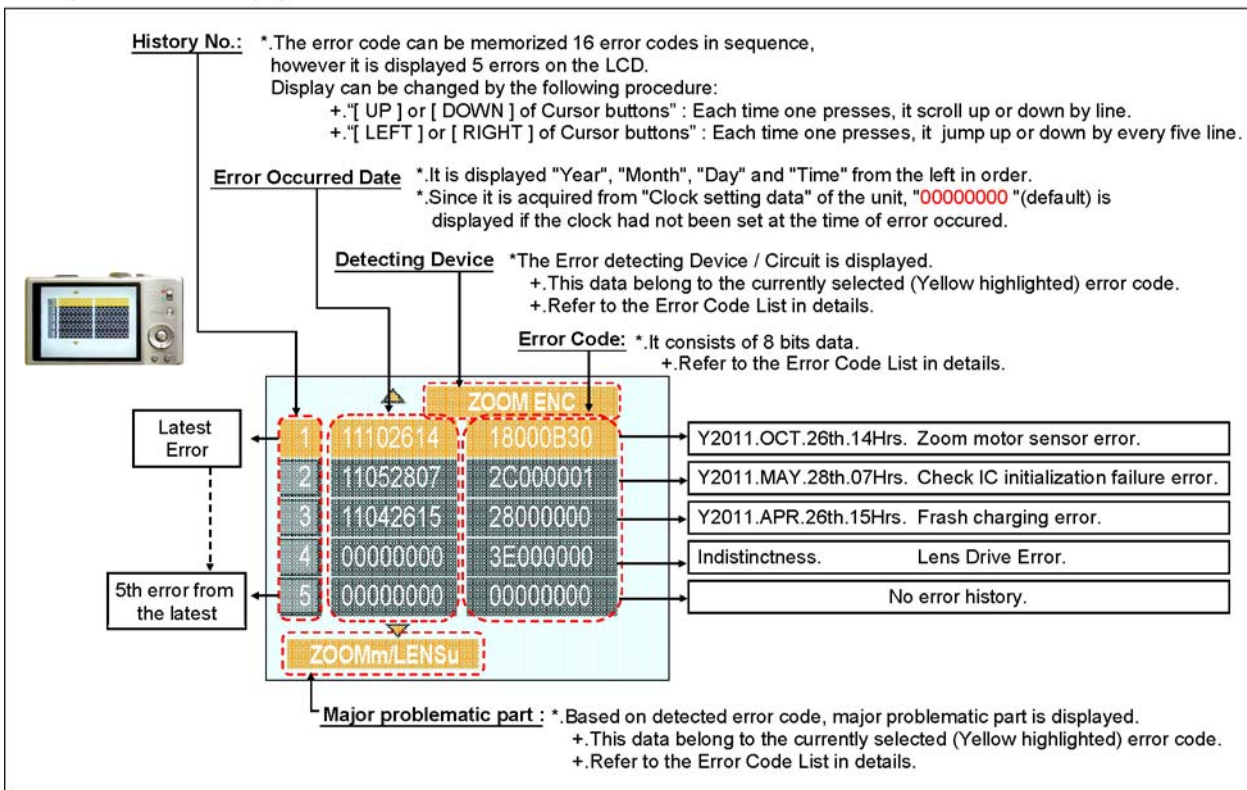

3. Error Code List

The error code consists of 8 bits data and it shows the following information.

Attribute	Main item	Sub item	Error code		Contents (Upper)	Error Indication	
			High 4bits	Low 4 bits	Check point (Lower)	Detecting device	Part/Circuit
LENS	Lens drive	OIS	18*0	1000	PSD (X) error. Hall element (X axis) position detect error in OIS unit. OIS Unit	OIS X	LENSu NG
				2000	PSD (Y) error. Hall element (Y axis) position detect error in OIS unit. OIS Unit	OIS Y	
			3000	GYRO (X) error. Gyro (IC7103) detect error on Top Operation P.C.B. IC7103 (Gyro element) or IC6001 (VENUS FHD)	GYRO X	GYRO NG	
				4000	GYRO (Y) error. Gyro (IC9701) detect error on Gyro P.C.B. IC9701 (Gyro element) or IC6001 (VENUS FHD)		GYRO Y
			5000	MREF error (Reference voltage error). IC9101 (LENS drive) or IC6001 (VENUS FHD)	OIS REF	LENSSd/DSP NG	
				6000	Drive voltage (X) error. LENS Unit, LENS flex breaks, IC6001(VENUS FHD) AD value error, etc.		OISX REF
			7000	Drive voltage (Y) error. LENS Unit, LENS flex breaks, IC6001(VENUS FHD) AD value error, etc.	OISY REF	LENSu/LENS FPC	
				Zoom (C.B.)	0?10		Collapsible barrel Low detect error (Collapsible barrel encoder always detects High.) Mechanical lock, FP9005-(29) signal line or IC6001 (VENUS FHD)
			0?20			Collapsible barrel High detect error (Collapsible barrel encoder always detects Low.) Mechanical lock, FP9005-(29) signal line or IC6001 (VENUS FHD)	ZOOM H
			0?30		Zoom motor sensor error. Mechanical lock, FP9005-(40), (42) signal line or IC6001 (VENUS FHD)	ZOOM ENC	
		0?40			Zoom motor sensor error. (During monitor mode.) Mechanical lock, FP9005-(40), (42) signal line or IC6001 (VENUS FHD)		
		0?50	Zoom motor sensor error. (During monitor mode with slow speed.) Mechanical lock, FP9005-(40), (42) signal line or IC6001 (VENUS FHD)				
			0?60				Phase error or operation failure of zoom Lens/motor/encoder. (IMPACT) Mechanical lock, zoom encoder.
		Focus	0?01		HP High detect error (Focus encoder always detects High, and not becomes Low) Mechanical lock, FP9005-(29) signal line or IC6001 (VENUS FHD)	FOCUS L	LENS FPC/DSP
					0?02	HP Low detect error (Focus encoder always detects Low, and not becomes High) Mechanical lock, FP9005-(29) signal line or IC6001 (VENUS FHD)	
		Lens	18*1	0000	Power ON time out error. Lens drive system	LENS DRV	LENSu
				18*2	0000		

Attribute	Main item	Sub item	Error code		Contents (Upper)	Error Indication	
			High 4bits	Low 4 bits	Check point (Lower)	Detecting device	Part/Circuit
	Adj.History	OIS	19*0	2000	OIS adj. Yaw direction amplitude error (small)	OIS ADJ	OIS ADJ
				3000	OIS adj. Pitch direction amplitude error (small)		
				4000	OIS adj. Yaw direction amplitude error (large)		
				5000	OIS adj. Pitch direction amplitude error (large)		
				6000	OIS adj. MREF error		
				7000	OIS adj. time out error		
				8000	OIS adj. Yaw direction off set error		
				9000	OIS adj. Pitch direction off set error		
				A000	OIS adj. Yaw direction gain error		
				B000	OIS adj. Pitch direction gain error		
				C000	OIS adj. Yaw direction position sensor error		
				D000	OIS adj. Pitch direction position sensor error		
				E000	OIS adj. other error		
HARD	VENUS A/D	Flash	28*0	0000	Flash charging error. IC6001-(AC18) signal line or Flash charging circuit	STRB CHG	STRB PCB/ FPC
	FLASH ROM (EEPROM Area)	FLASH ROM (EEPROM Area)	2B*0	0001	EEPROM read error	FROM RE	FROM
				0003	IC6001 (FLASH ROM)	FROM WR	FROM
				0004	EEPROM write error		
				0002	IC6001 (FLASH ROM)		
				0005	Firmware version up error Replace the firmware file in the SD memory card.	(No indication)	(No indication)
	0008	SDRAM error	(No indication)	(No indication)			
	0009	SDRAM Mounting defective					
	SYSTEM	RTC	2C*0	0001	SYSTEM IC initialize failure error Communication between IC6001 (VENUS FHD) and IC9101 (SYSTEM)	SYS INIT	MAIN PCB
	SOFT	CPU	Reset	30*0	0001 0007	NMI reset Non Mask-able Interrupt (30000001-30000007 are caused by factors)	NMI RST
Card		Card	31*0	0001	Card logic error SD memory card data line or IC6001 (VENUS FHD)	SD CARD	SD CARD/ DSP
				0002	Card physical error SD memory card data line or IC6001 (VENUS FHD)		
				0004	Write error SD memory card data line or IC6001 (VENUS FHD)		
				0005	Format error	SD WRITE	
				0001	Camera task finish process time out. Communication between Lens system and IC6001 (VENUS FHD)	INMEMORY	FROM
CPU, ASIC hard		Stop	38*0	0001	Camera task finish process time out. Communication between Lens system and IC6001 (VENUS FHD)	LENS COM	LENSu/DSP
				0002	Camera task invalid code error. IC6001 (VENUS FHD)	DSP	DSP
				0100	File time out error in recording motion image IC6001 (VENUS FHD)	DSP	DSP
				0200	File data cue send error in recording motion image IC6001 (VENUS FHD)		
				0300	Single or burst recording brake time out.		
Memory area		Memory area	3A*0	0008	work area partitioning failure USB dynamic memory securing failure when connecting	(No indication)	(No indication)
				0000	FLASH ROM processing early period of camera during movement.	INIT	(No indication)
Operation	Power on	3B*0	0000	FLASH ROM processing early period of camera during movement.	INIT	(No indication)	
Zoom	Zoom	3C*0	0000	Imperfect zoom lens processing Zoom lens	ZOOM	ZOOMm/ LENSu	
			0000	Software error (0-7bit : command, 8-15bit : status)	DSP	DSP	
		35*1	0000	Though record preprocessing is necessary, it is not called.	(No indication)	(No indication)	
		35*2	0000	Though record preprocessing is necessary, it is not completed.			

Important notice about "Error Code List"

1) About "*" indication:

The third digit from the left is different as follows.

+In case of 0 (example: 18 **0** 01000)

When the third digit from the left shows "0", this error occurred under the condition of INITIAL SETTINGS has been completed.
It means that this error is occurred basically at user side.

+In case of 8 (example: 18 **8** 01000)

When the third digit from the left shows "8", this error occurred under the condition of INITIAL SETTINGS has been released.
(Example; Factory assembling-line before unit shipment, Service mode etc.)
It means that this error is occurred at service side.

2) About "?" indication: ("18*0 0?01" to "18*0 0?50"):

The third digit from the right shows one of the hexadecimal ("0" to "F") character.

4. How to exit from Error Code display mode:

Simply, turn the power off. (Since Error code display mode is executed under the condition of temporary cancellation of "INITIAL SETTINGS", it wake up with normal condition when turn off the power.)

Note:

The error code can not be initialized.

6.2. ICS (Indication of additional Camera Settings when picture was taken) function

1. General description

This unit is equipped with ICS (ICS : Indication of additional Camera Settings when picture was taken) function by playing back the concerned picture on the LCD display.

(This function is achieved by utilizing "maker note" data stored in Exif data area of recorded picture file.)

To proceed failure diagnosis, use this ICS function together with "displaying the recorded picture with picture information" function.

Note:

- *.The ICS function operates with a picture which is only taken with the same model. (It may not be displayed when the picture was taken with other model.)
- *.Since Exif data is not available after the picture is edited by PC, the ICS function may not be activated.

2. How to display

The ICS data is displayed by ordering the following procedure:

• Preparation:

- 1.Attach the Battery or AC Adaptor with a DC coupler to the unit.
2. Set the mode dial to the PROGRAM AE mode.

• Step 1. The temporary cancellation of "INITIAL SETTINGS":

Set the REC/PLAYBACK selector switch to "REC (Camera mark)".

While keep pressing "UP of Cursor button" and MOTION PICTURE button simultaneously, turn the Power on.

• Step 2. Execute the ICS display mode:

Set the REC/PLAYBACK selector switch to PLAYBACK.

Select the concerned picture by pressing the "LEFT and RIGHT of Cursor button".

Press the "LEFT of Cursor button", MENU/SET button and MOTION PICTURE button simultaneously.

Press the DISPLAY button, 3 times.

The display condition is changed as shown below when the DISPLAY button is pressed.

Code display → Code + Picture display (1) → Code + Picture display (2) → ICS display →

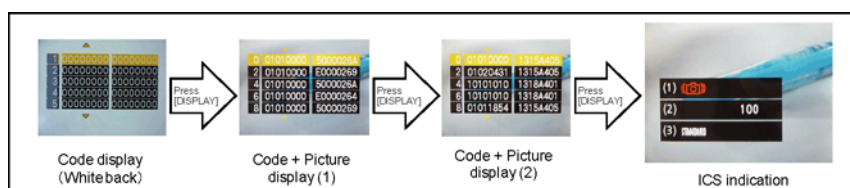

3. How to read

(1). Jitter alert was displayed or not:
 This part shows that the "Jitter alert" mark was displayed or not when the picture has just before been taken.
 + With "Jitter alert" mark : The "Jitter alert" mark was displayed.
 + Without "Jitter alert" mark: The "Jitter alert" mark was not displayed.
 [About "Jitter alert" mark]
 Due to lacking the enough light amount etc, shooting condition prone to make a "hand jitter", the "Jitter alert" mark is displayed.
 [Reference Guide]
 (Applicable settings : Normal picture mode, ISO100, WIDE edge, Flash OFF)
 + The "Jitter alert" mark is displayed when the shutter speed is 1/15th and below.

(2). ISO Sensitivity Setting condition:
 This part shows that the "ISO Sensitivity" setting condition when the picture had been taken.
 (Note: The [i ISO] is displayed when the "Intelligent ISO" was selected.)
 For instance, when the recorded picture information shows [ISO100], it can be confirmed the ISO setting condition : [AUTO], [INTELLIGENT ISO] or [ISO100](Fixed: set by user).
 [Point for Confirmation]
 *The symptom is "Picture with "hand jitter". Subject is not clearly stopped." in darker scene, does the picture was taken with lower ISO setting mode?
 *The symptom is "Noisy picture. Rough picture image" in brighter scene, does the picture was taken with higher ISO setting mode?

(3). Color mode Setting condition:
 This part shows that the "Color mode" setting condition when the picture had been taken.
 [Point for Confirmation]
 *The symptom is "Color is strange. The picture is bluish (Yellowish)", does the picture was taken with [SEPIA][COOL]/[WARM] settings?
 NOTE: As for the symptom related with the color, confirm the picture information which is displayed in normal playback screen as well.
 (In normal playback screen, the setting condition of "White balance" and "WB Adjustment" can be confirmed.)

[ICS display (Sample)]

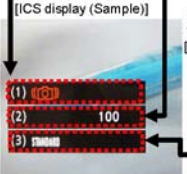

(1) Jitter alert mark : [Indicated]
 (2) ISO sens. setting: ISO100 (Fixed)
 (3) Color mode setting: Standard

Normal playback screen (Recorded picture with information)



*In playback mode, the picture information is displayed when pressing the [DISPLAY] button. (It can be confirmed at user as well.)
 *Use this indication together with ICS function.

[Reference Guide : Settings "When taking picture"]

<ISO SENSITIVITY>
 *This allows the sensitivity to light (ISO sensitivity) to be set. Setting to a higher figure enables pictures to be taken even in dark places without the resulting pictures coming out dark.
 *In this unit, it can be set one of the [AUTO], [i ISO], [100], [200], [400], [800] and [1600] in "Normal shooting" mode.
 (The ISO sensitivity setting is not available when the [INTELLIGENT ISO] is being used.)
 *When setting to [AUTO], the ISO sensitivity is automatically adjusted to a maximum of [ISO400] according to the brightness.
 (It can be adjusted to a maximum of [ISO1000] when using the flash.)
 *When setting to [iISO], the ISO sensitivity is automatically adjusted to a maximum of [ISO1600].
 *To avoid picture noise, we recommend that you either reduce the ISO sensitivity level or set [COLOR MODE] to [NATURAL], and then take pictures.

	[100]	[1600]
Recording location (recommended)	When it is light (outdoors)	When it is dark
Shutter speed	Slow	Fast
Noise	Less	Increased
Jitter of the subject	Increased	Less

<COLOR MODE>
 *Using these modes, the pictures can be made sharper or softer, the colors of the pictures can be turned into sepia colors or other color effects can be achieved.
 *In this unit, it can be set one of the following effects in "Normal shooting" mode.

[STANDARD] : This is the standard setting.	[BW] : The picture becomes black and white.
[NATURAL] : The picture becomes softer.	[SEPIA] : The picture becomes sepia.
[VIVID] : The picture becomes sharper.	[COOL] : The picture becomes bluish.
	[WARM] : The picture becomes reddish.

NOTE: You cannot set [NATURAL], [VIVID], [COOL] or [WARM] in Intelligent auto mode.
 *When you take pictures in dark places, noise may become visible. To avoid noise, we recommend setting to [NATURAL].



4. How to exit

Simply, turn the power off. (Since ICS function is executed under the condition of temporary cancellation of "INITIAL SETTINGS", it wake up with normal condition when turn off the power.)

7 Troubleshooting Guide

7.1. Checking Method of GPS failure (Except: ZS10GK)

1. GENERAL DESCRIPTION

- **About the camera's location name information**
Before using the camera, read "User License Agreement for Location Name Data".
- **When [GPS Setting] is [ON], the GPS function works even if the camera's power is off.**
 - Electromagnetic waves from the camera can affect instruments and meters. During airplane takeoff and landing or in other restricted area, set [GPS Setting] to [OFF] or , then turn the camera's power off.
 - When [GPS Setting] is [ON], power will drain from the battery even if the camera's power is OFF.
- **Recording location information**
 - The names of recording locations and landmarks (such as buildings) are current as of December 2010. These will not be updated.
 - Depending on the country or area, limited location name and landmark information may be available.
- **Positioning**
 - Positioning will take time in environments where it is difficult to receive the signals from the GPS satellites.
 - **Even if GPS reception is good, it will take approximately 2 to 3 minutes to successfully execute positioning under the following conditions; when positioning is executed for the first time, or when positioning is executed after the camera is turned off with the [GPS Setting] set to  and then turned on again or when [GPS Setting] is set to [OFF].**
 - Because the positions of the GPS satellites are constantly changing, depending on the recording location and conditions, it may not be possible to position such satellites accurately, or positioning discrepancy may occur.

Note:

- **DMC-ZS10GK does not equipped with GPS function.**
 - **When using in another country**
 - GPS may not work in China or in the border regions of countries neighboring China. (Current as of February 2010)
 - Some countries or regions may regulate the use of GPS or related technology.
- Because this camera has a GPS function, before taking it into another country, check with the embassy or your travel agency whether there are any restrictions on bringing cameras with a GPS function.

2. Checking flowchart of GPS failure.

The checking flowchart of GPS failure is as follows:

Note:

*Perform the GPS communication test, even if the repair being carried out is not related with GPS function.

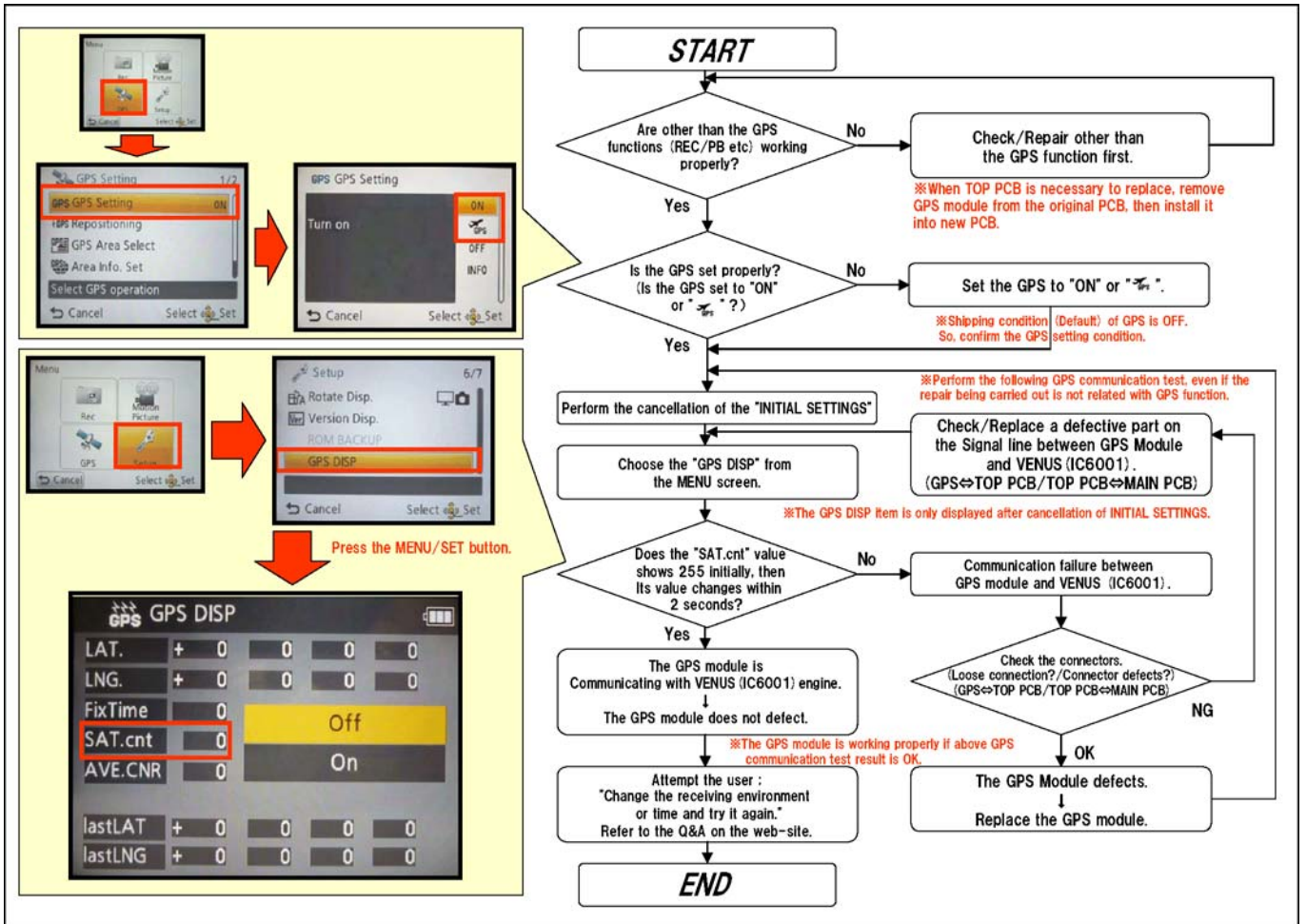

*The GPS function in this unit is performed communication between GPS module (on the top P.C.B.) and VENUS (IC6001: on the MAIN P.C.B.).



8 Service Fixture & Tools

8.1. Service Fixture and Tools

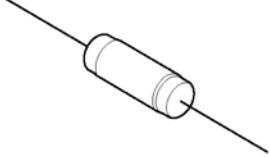
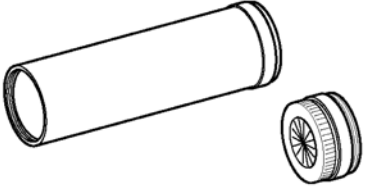
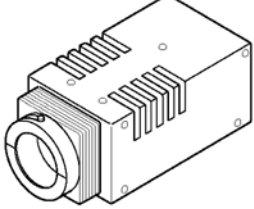
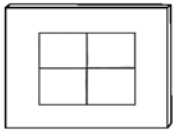
The following Service Fixture and tools are used for checking and servicing this unit.

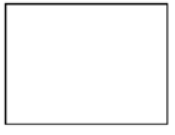
Resistor for Discharging ERG5SJ102	Infinity Lens (Built-in Focus Chart) VFK1164TCM02	LIGHT BOX VFK1164TDVLB
 <p>An equivalent type of Resistor may be used.</p>	 <p>※ RFKZ0422 can be used.</p>	 <p>※ with DC Cable</p>
TR Chart RFKZ0443	Lens Cleaning Kit (BK) VFK1900BK	Grease (for Lens) (for focus motor) RFKZ0472
	 <p>* Only supplied as 10 set/box.</p>	
ND Filter VFK1164ND15		
		

8.2. When Replacing the Main P.C.B.

After replacing the MAIN P.C.B., be sure to achieve adjustment.

The Maintenance software (DIAS) is available at "software download" on the "Support Information from NWBG/VDBG-AVC" web-site in "TSN system".

8.3. Service Position

This Service Position is used for checking and replacing parts. Use the following Extension cables for servicing.

No.	Parts No.	Connection	Form
1	VFK1541	FP9004 (MAIN) - PS9901 (TOP OPERATION P.C.B.)	40PIN B to B
2	VFK1906	PP8001 (FLASH P.C.B.) - PS9903 (TOP OPERATION P.C.B.)	20PIN B to B

8.3.1. Extension Cable Connections

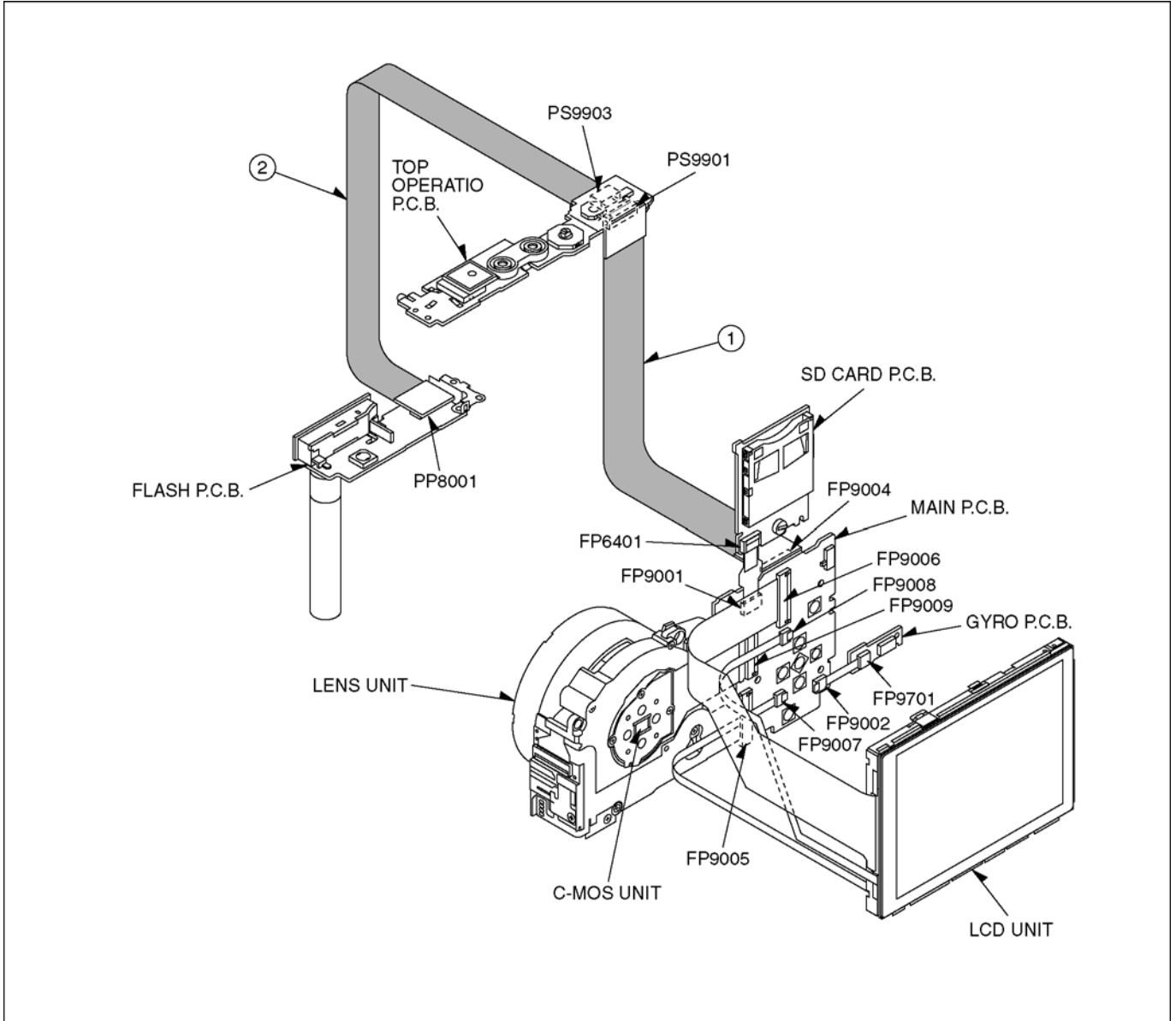

CAUTION-1. (When servicing FLASH P.C.B.)

1. Be sure to discharge the capacitor on FLASH P.C.B.
Refer to "HOW TO DISCHARGE THE CAPACITOR ON FLASH P.C.B."
The capacitor voltage is not lowered soon even if the AC Cord is unplugged or the battery is removed.
2. Be careful of the high voltage circuit on FLASH P.C.B.
3. DO NOT allow other parts to touch the high voltage circuit on FLASH P.C.B.

9 Disassembly and Assembly Instructions

9.1. Disassembly Flow Chart

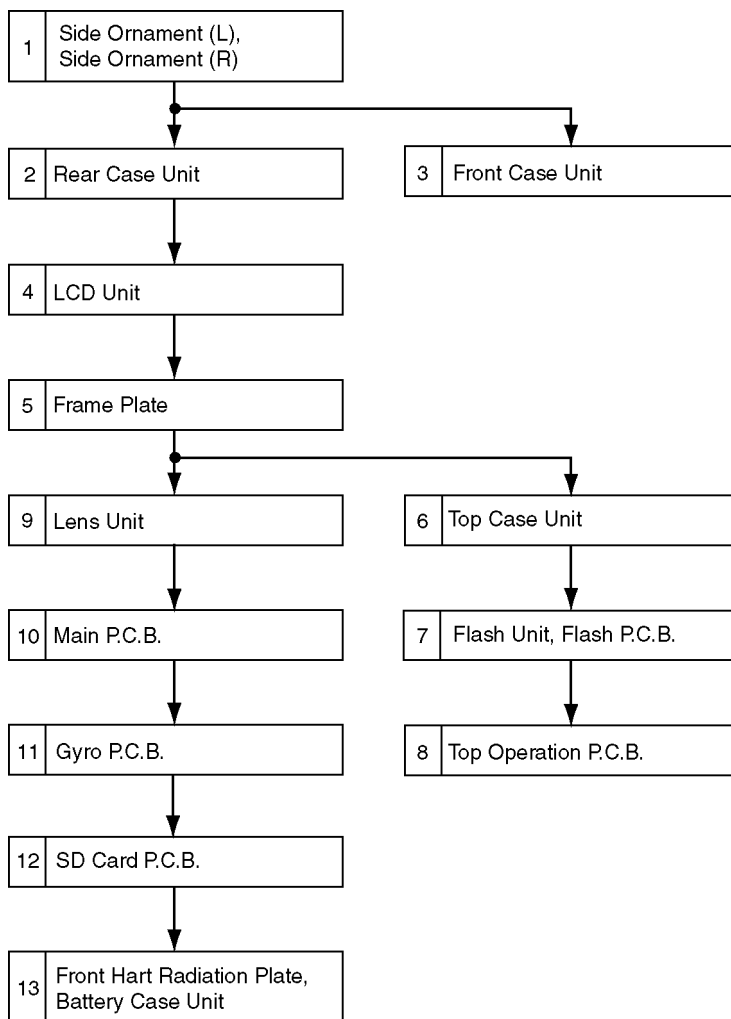

9.2. P.C.B. Location

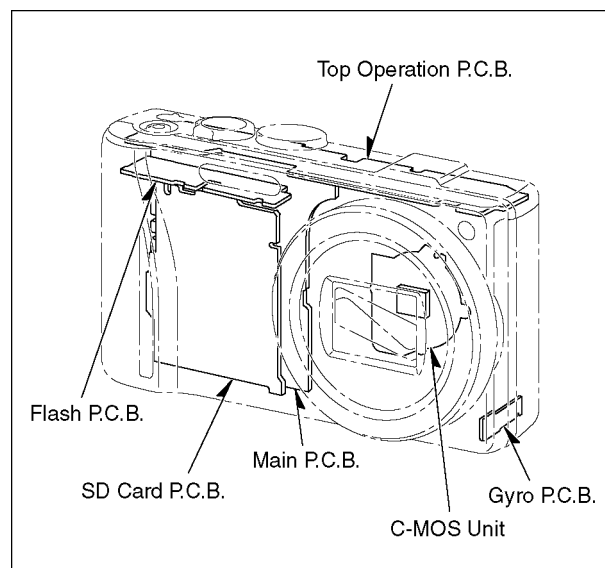

9.3. Disassembly Procedure

No.	Item	Fig.	Removal
1	Side Ornament (L) / (R)	Fig.D1	SD Card
			Battery
			4 Screws (A)
			2 Locking tabs
			Side Ornament (L)
			Side Ornament (R)
2	Rear Case Unit	Fig.D2	2 Screws (B)
			Rear Case Unit
3	Front Case Unit	Fig.D3	1 Screw (C)
			Front Case Unit
4	LCD Unit	Fig.D4	FP9006 (Flex)
			FP9007 (Flex)
			FP9008 (Flex)
			2 Locking tabs
			LCD Unit
5	Frame Plate	Fig.D5	3 Screws (D)
			3 Locking tabs
			Frame Plate
6	Top Case Unit	Fig.D6	3 Locking tabs
			PS9901 (Connector)
			Top Case Unit
7	Flash Unit, Flash P.C.B.	Fig.D7	1 Screw (E)
			PP8001(Connector)
			Flash Unit
			Flash P.C.B.
8	Top Operation P.C.B.	Fig.D8	2 Locking tabs
			AF Panel Light
			1 Screw (F)
			FP9902 (Flex)
			Flash Spacer
			6 Locking tabs
			Top Operation P.C.B.
			Top Operation P.C.B.
9	Lens Unit	Fig.D9	FP9005 (Flex)
			FP9009 (Flex)
			3 Screws (G)
			Lens Unit
10	Main P.C.B.	Fig.D10	FP9001 (Flex)
			FP9002 (Flex)
			2 Screws (H)
			1 Locking tab
			Main P.C.B.
11	Gyro P.C.B.	Fig.D11	Gyro P.C.B.
12	SD Card P.C.B.	Fig.D12	1 Screw (I)
			2 Locking tabs (A)
			PCB Spacer
			Main Heat Radiation Plate
			2 Locking tabs (B)
13	Front Heat Radiation Plate Battery Case Unit	Fig.D13	3 Locking tabs (C)
			Front Heat Radiation Plate
			2 Locking tabs (D)
			Battery Case Unit

9.3.1. Removal of the Side Ornament (L), Side Ornament (R)

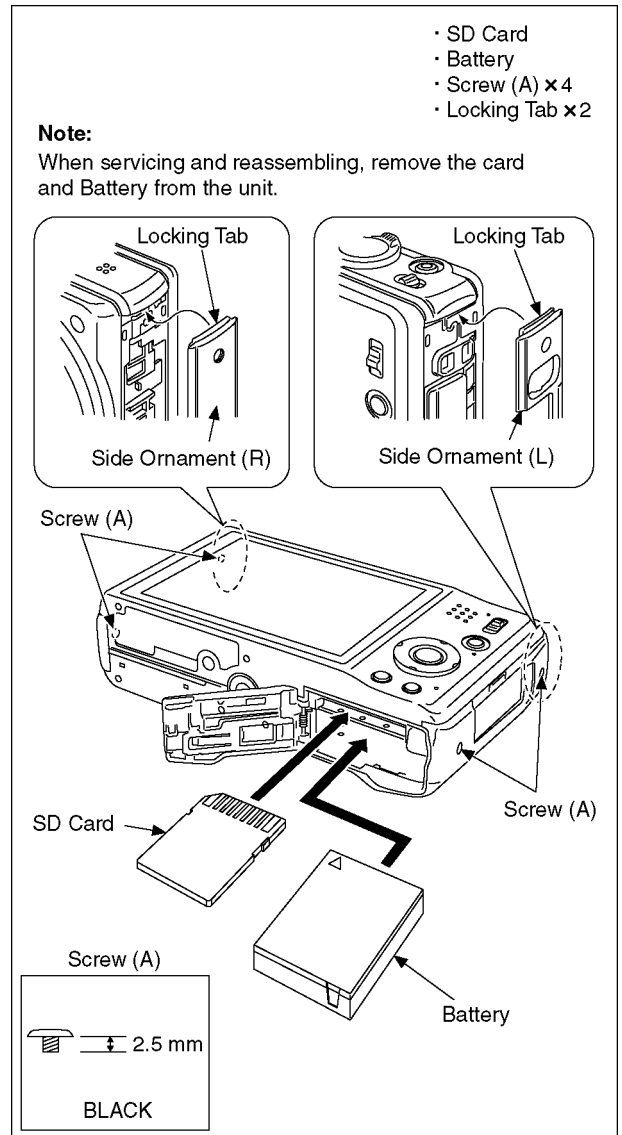

Fig. D1

9.3.2. Removal of the Rear Case Unit

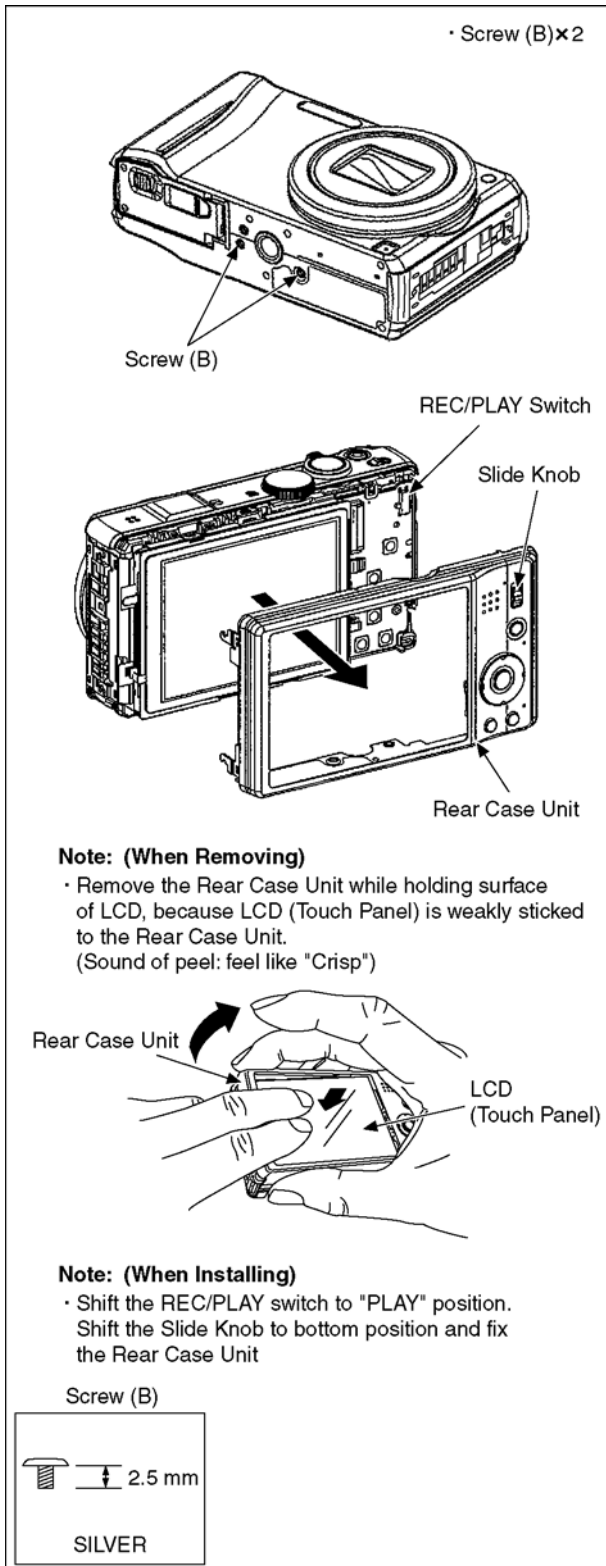

Fig. D2

When removing the Rear Case Unit, the protection sheet tape may be damaged. (roll up, separated...)

In such a case, peel it off from the Rear Case Unit and replace it with new one.

Precaution (About Rear LCD Sheet):

In some of the early production units, there is a Rear LCD Sheet on the Rear Case Unit.

1. When you replace the protection sheet with new one, peel off the Rear LCD Sheet in advance.
(The Rear LCD Sheet is no longer needed after replacing the protection sheet with a new one.)
2. When replacing the Frame plate with a new one, make sure to peel off the Rear LCD sheet.

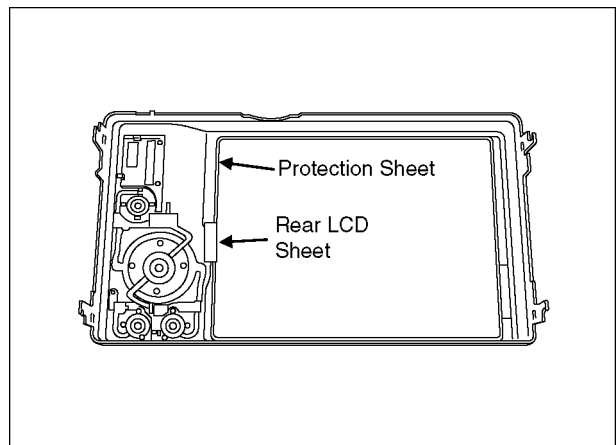

Procedures:

1. Peel off the left-half of the bottom side separator.

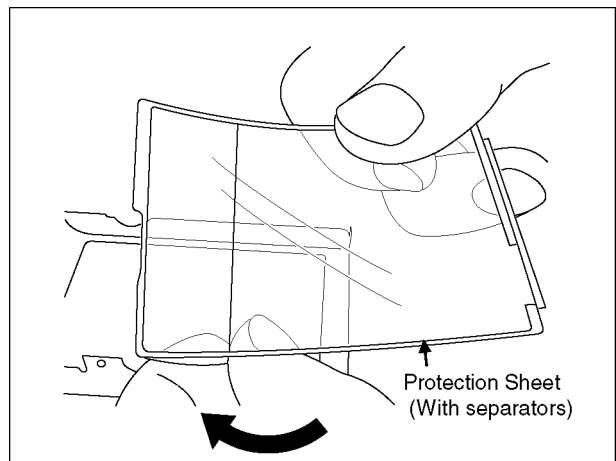

- Stick the sheet tape to the Rear Case Unit by aligning the rising edge of Rear Case Unit with the sheet tape.
(Confirm that there is no protrusion.)

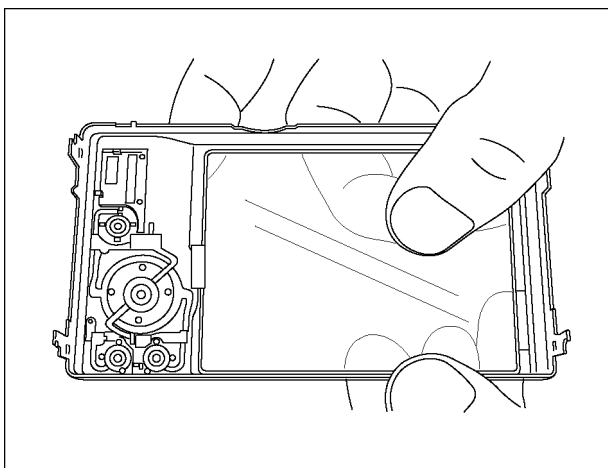

- Peel off the Right-half of the bottom side separator gently. Then press the sheet tape, firmly.

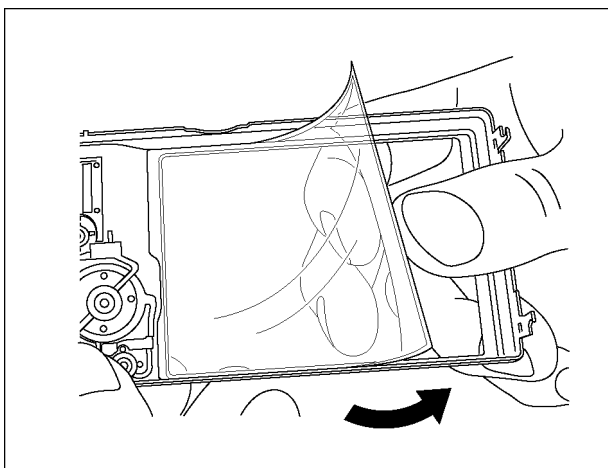

- Place your finger into the slit part of separator, and peel off the top side separator, gently.

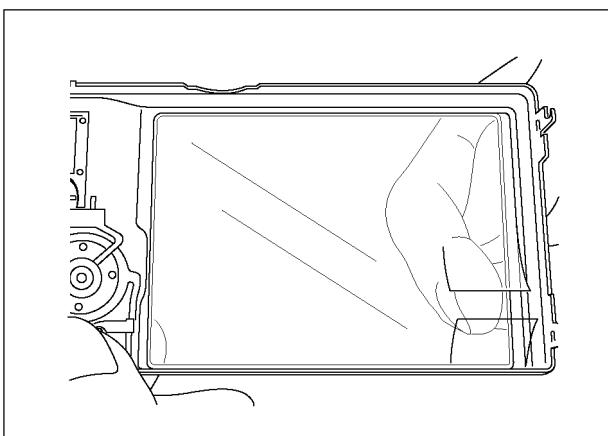

9.3.3. Removal of the Front Case Unit

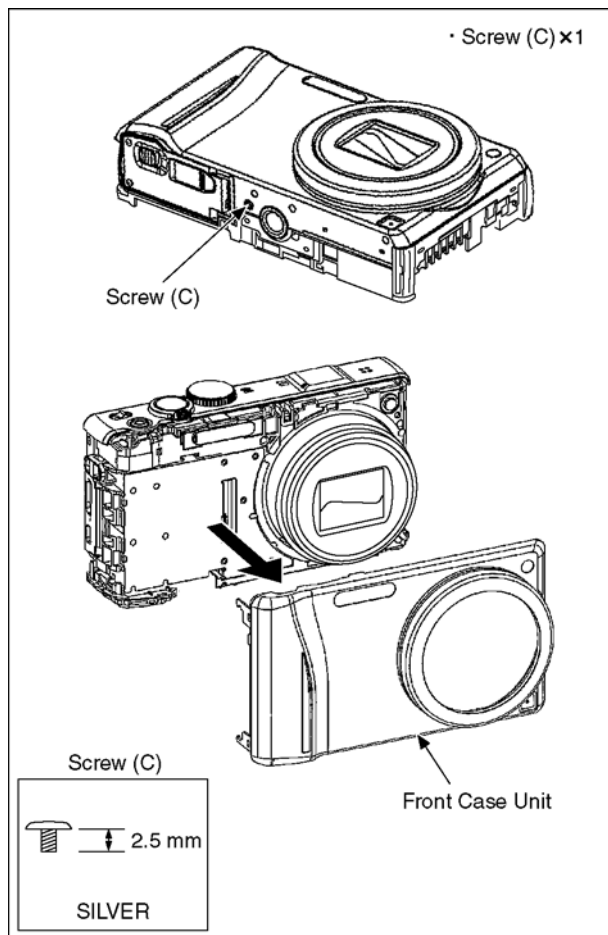

Fig. D3

9.3.4. Removal of the LCD Unit

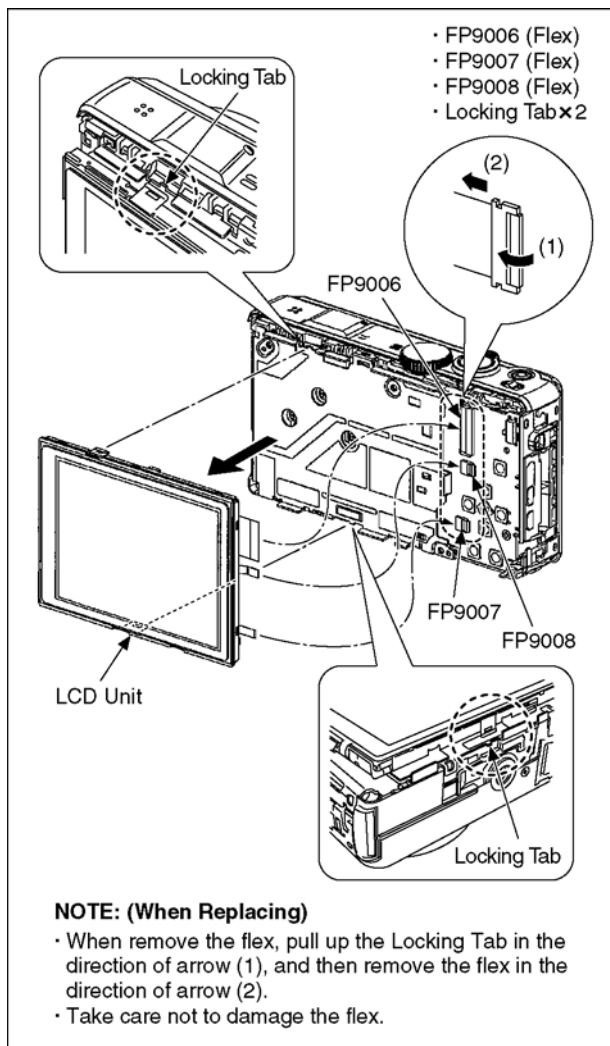

Fig. D4

9.3.5. Removal of the Frame Plate

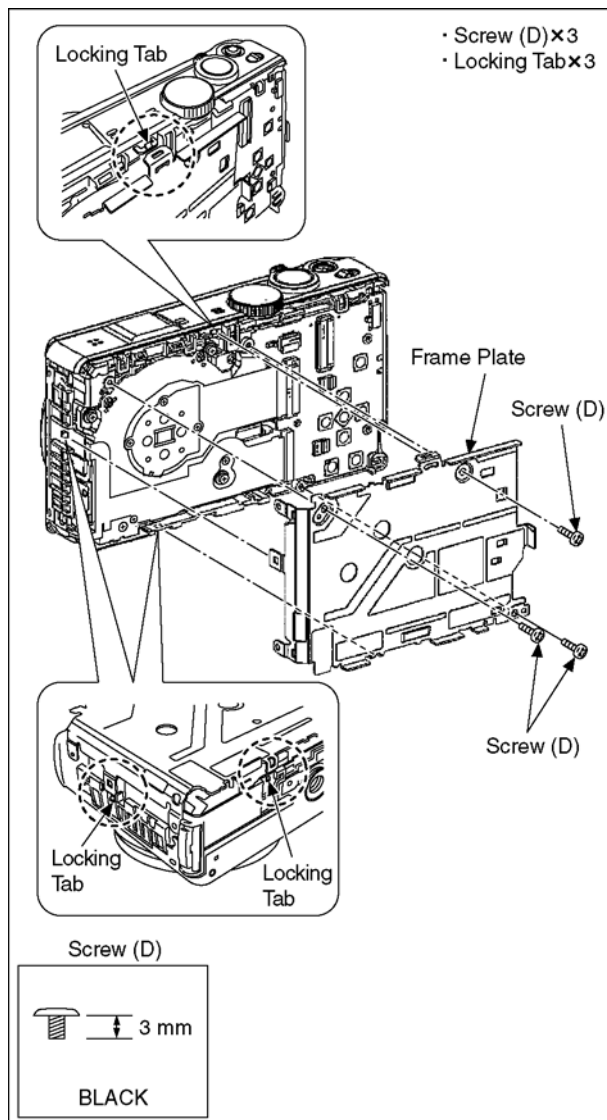

Fig. D5

9.3.6. Removal of the Top Case Unit

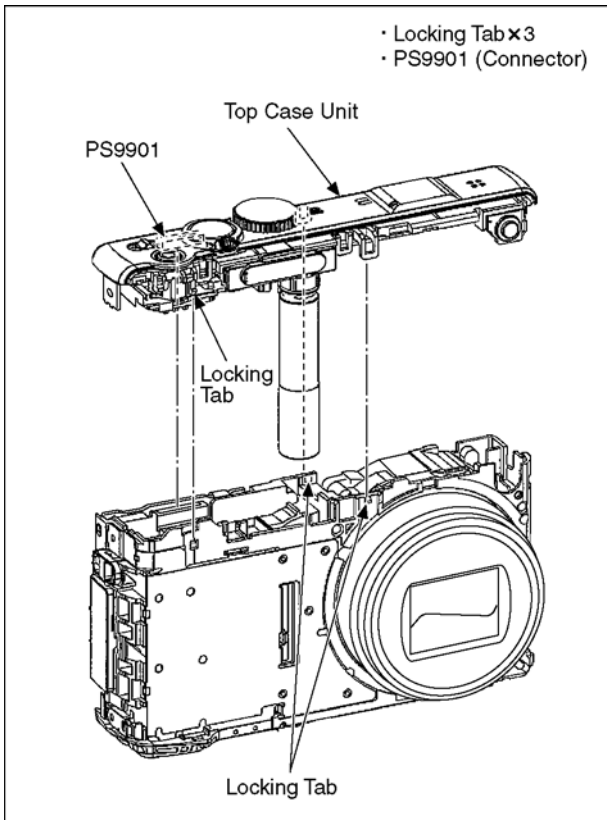

Fig. D6

9.3.7. Removal of the Flash Unit, Flash P.C.B.

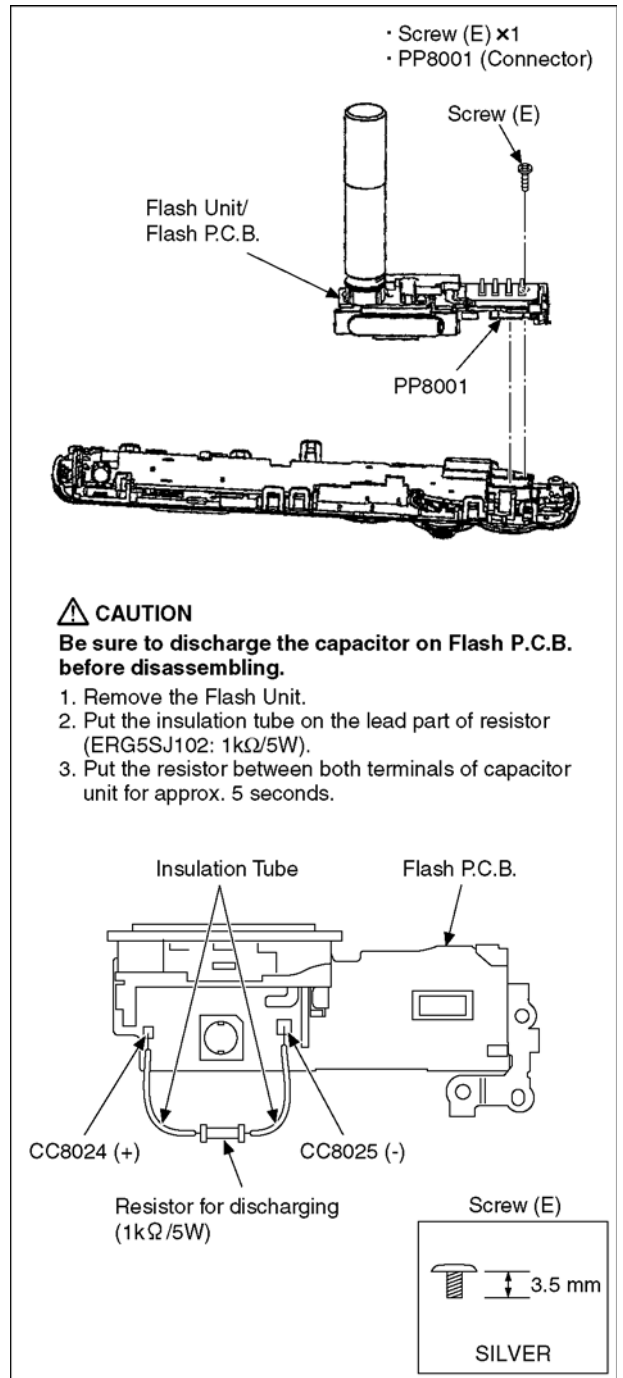

Fig. D7

9.3.8. Removal of the Top Operation P.C.B.

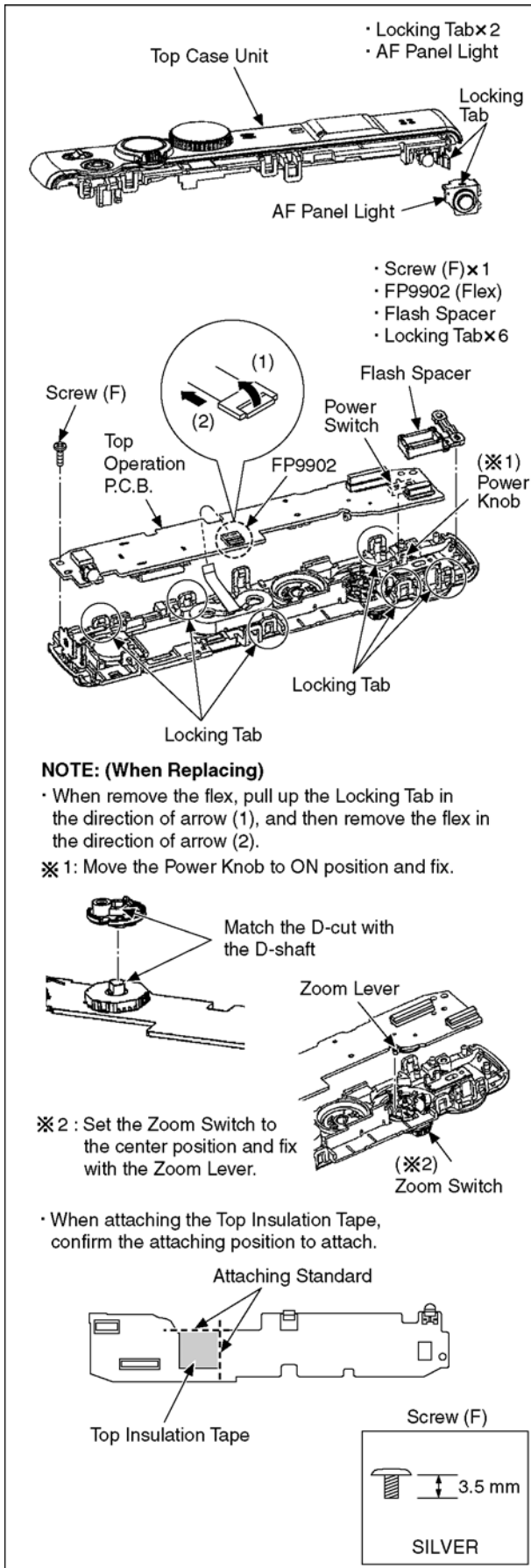

Fig. D8

9.3.9. Removal of the Lens Unit

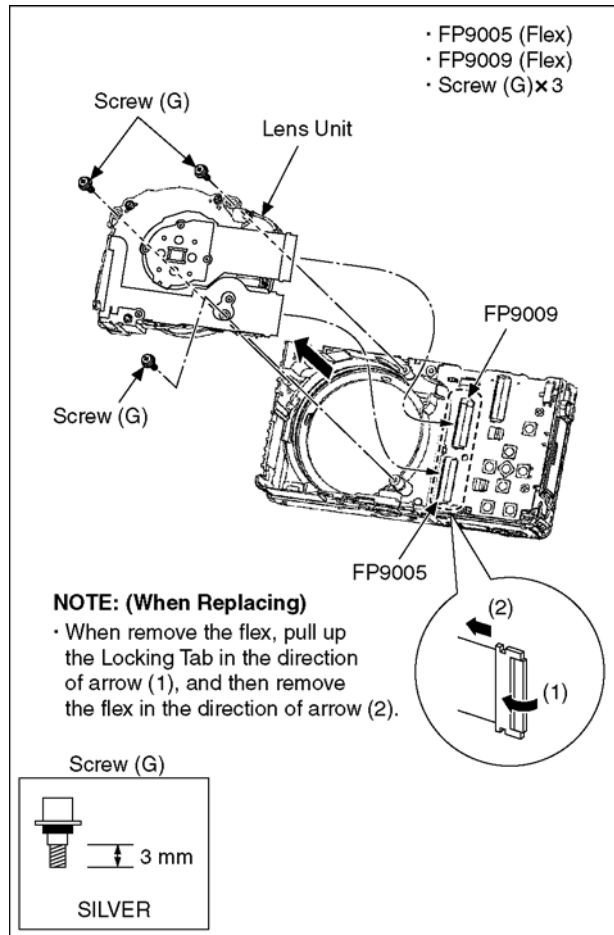

Fig. D9

9.3.10. Removal of the Main P.C.B.

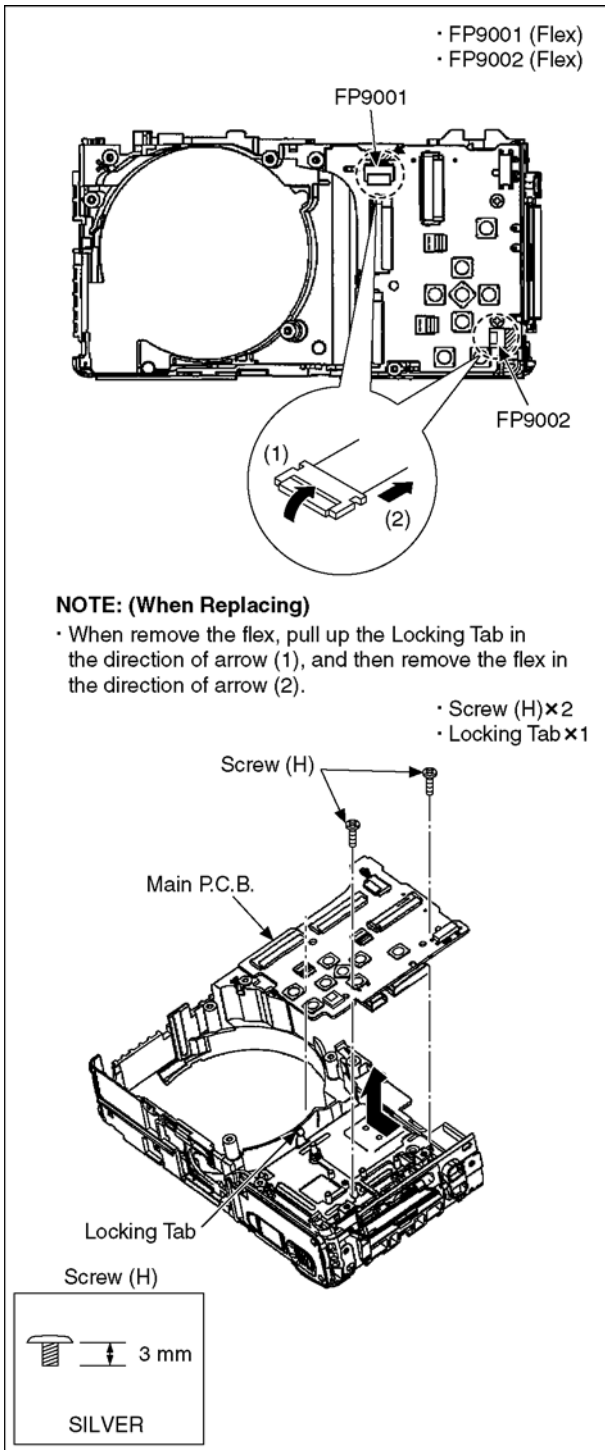

Fig. D10

9.3.11. Removal of the Gyro P.C.B.

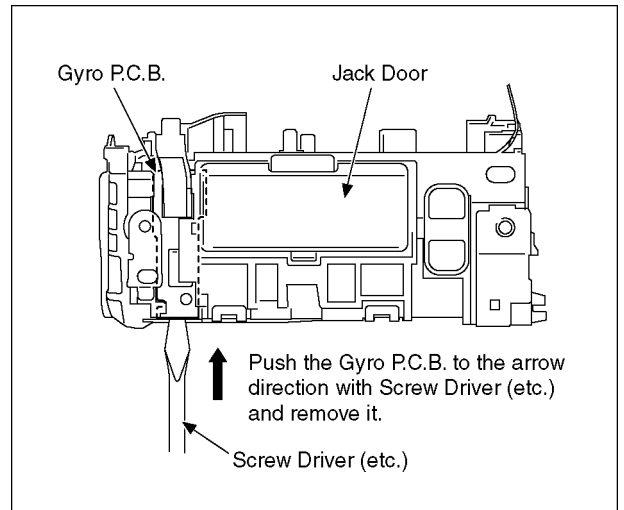

Fig. D11

9.3.12. Removal of the SD Card P.C.B.

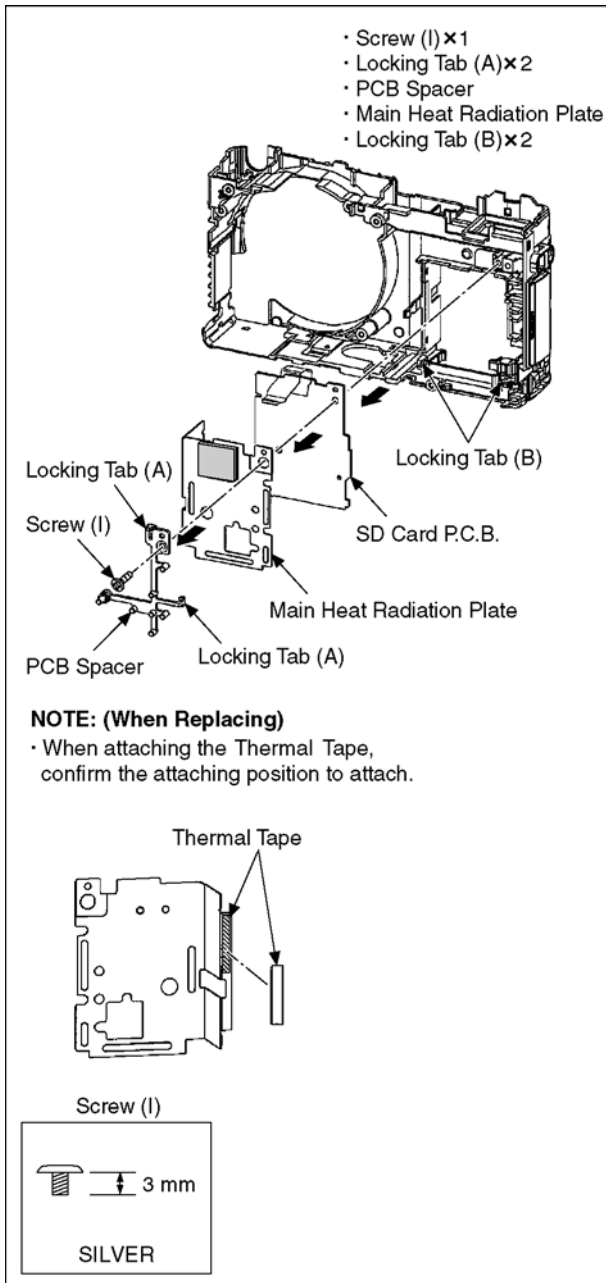

Fig. D12

9.3.13. Front Heat Radiation Plate, Battery Case Unit

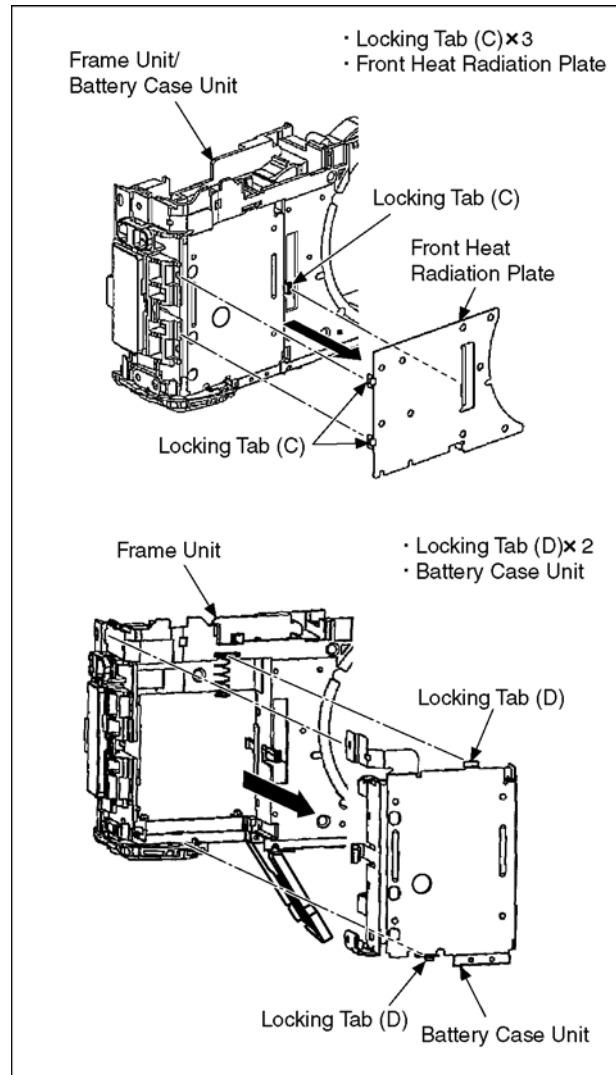

Fig. D13

9.4. Lens Disassembly Procedure

Precaution:

1. Do not remove the C-MOS when disassembling or re-assembling the lens in order to maintain it clean.
When remove it, refer to item "8.6".
2. Keep dust or dirt away from the lens.
3. To remove dirt or dust from the lens, blow with dry air.
4. Do not touch the lens surface.
5. Use lens cleaning KIT (BK)(VFK1900BK).
6. Apply grease (RFKZ0472) as shown on "THE APPLICATION OF GREASE METHOD" in the figure.
7. Apply a light coat of grease using an object similar to a toothpick.

9.4.1. Removal of the Zoom Motor Unit and Master Flange Unit

1. Unscrew the 2 screws (A).
2. Remove the Zoom Motor Unit.
3. Unscrew the 4 screws (B).
4. Remove the Connector (24p).
5. Remove the Connector (10p).
6. Remove the Master Flange Unit.

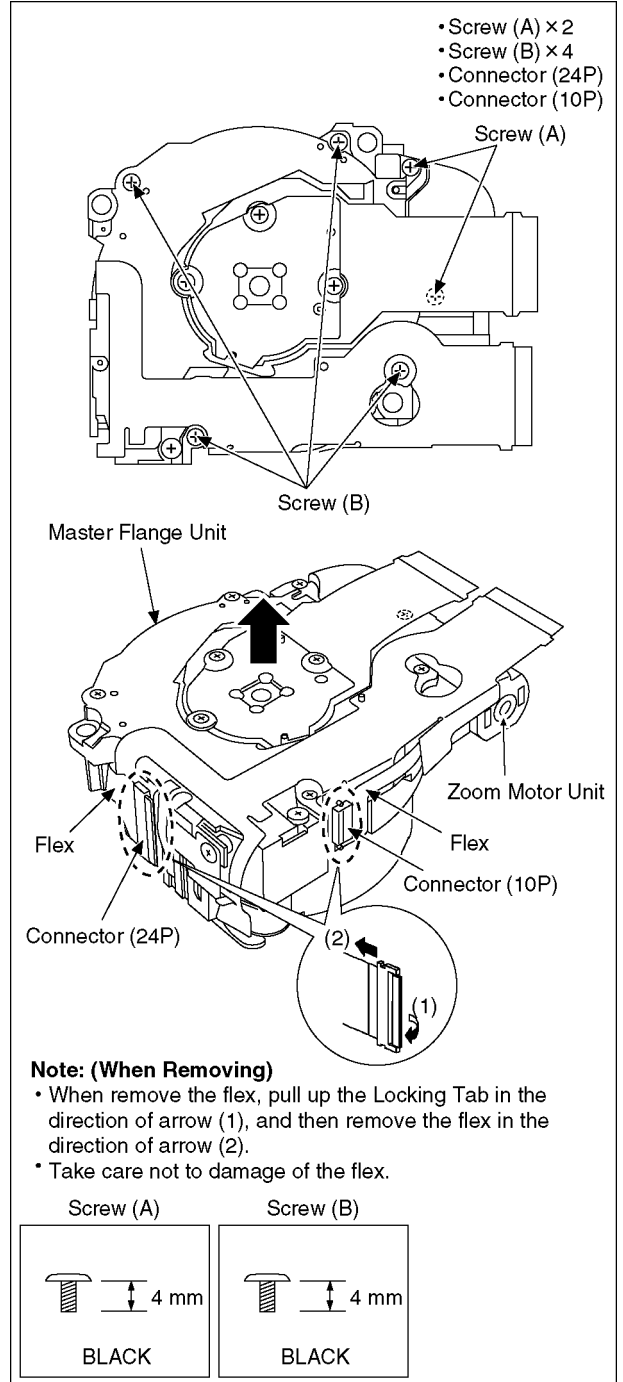

9.4.2. Removal of the 1st Direct Frame, 2nd/3rd Direct Frame, Both Side Cam Frame, 1st Lens Frame Unit, 2nd Lens Frame Unit, 3rd Lens Frame Unit and Fix Cam Frame Unit

- While keep Rotary Frame to the indicated by arrow (1), align the Cam pin and the groove.
- Push the 1st Lens Frame Unit to the indicated by arrow (2) from the front of the Lens, and then remove the Unit of 1st Direct Frame, 2nd/3rd Direct Frame, Both Side Cam Frame, 1st Lens Frame Unit, 2nd Lens Frame Unit, 3rd Lens Frame Unit and Fix Cam Frame Unit from the Rotary Frame.

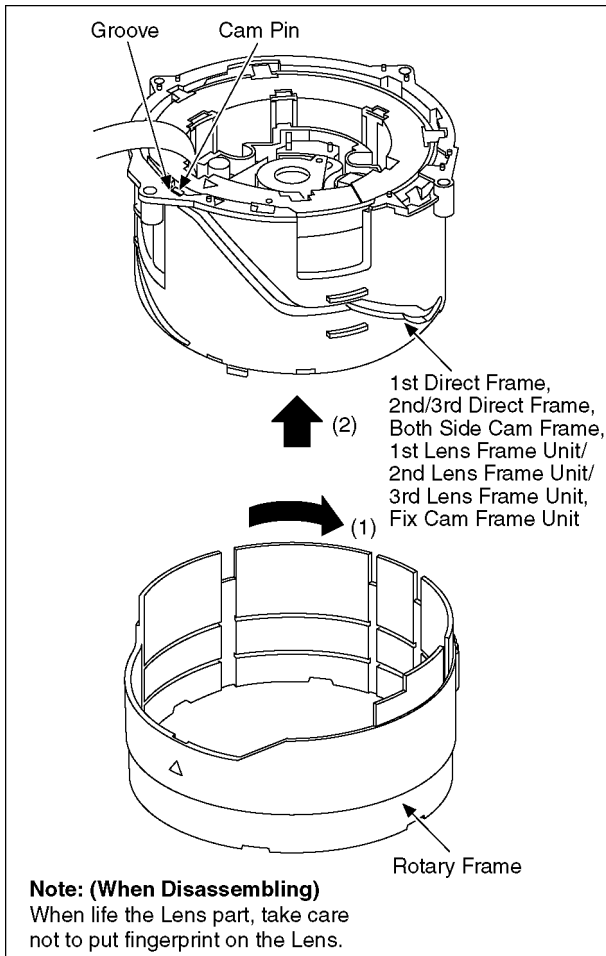

9.4.3. Removal of the 1st Direct Frame, 2nd/3rd Direct Frame, Both Side Cam Frame and 1st Lens Frame Unit/2nd Lens Frame Unit/3rd Lens Frame Unit

1. Turn the Both Side Cam Frame slightly, and then align the groove of Fix Cam Frame Unit and Pin of Both Side Cam Frame.

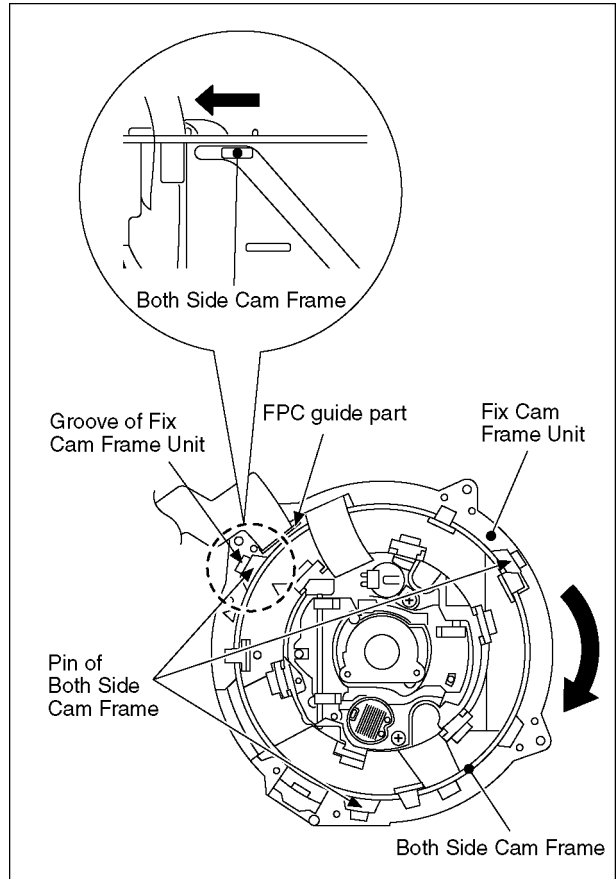

2. Push the 1st Lens Frame Unit to the indicated by arrow from Lens Side, and then remove the Unit of 1st Direct Frame, 2nd/3rd Direct Frame, Both Side Cam Frame and 1st Lens Frame Unit/2nd Lens Frame Unit/3rd Lens Frame Unit from the Fix Cam Frame Unit.

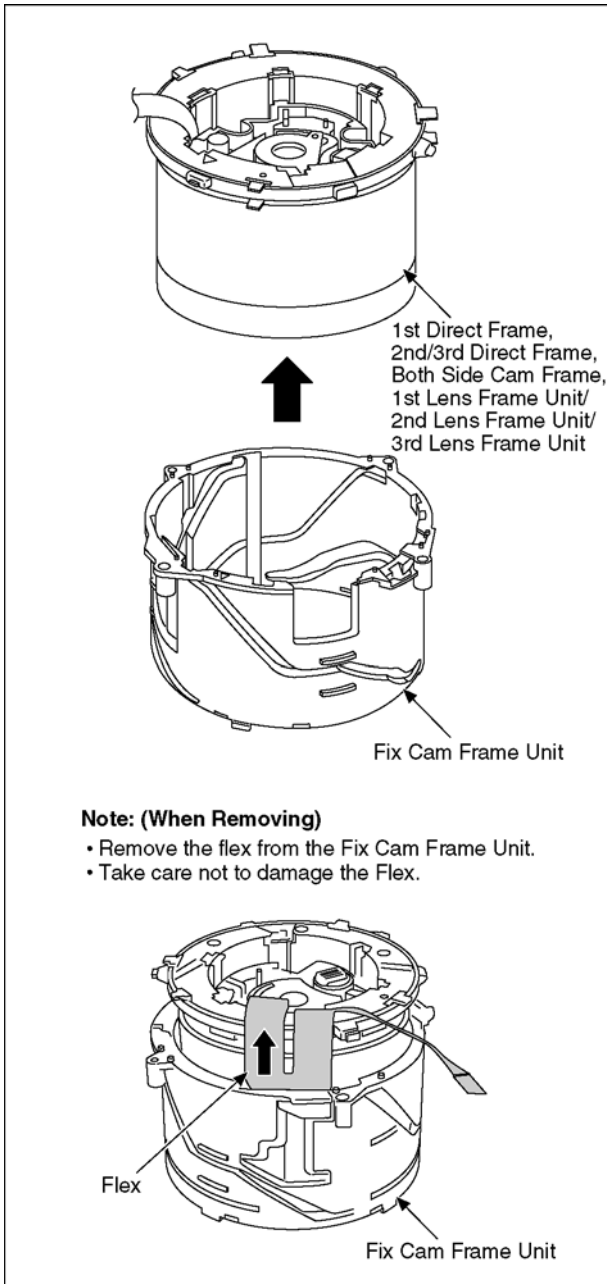

9.4.4. Removal of the 2nd/3rd Direct Frame, Both Side Cam Frame and 1st Lens Frame Unit/2nd Lens Frame Unit/3rd Lens Frame Unit

- Turn to the indicated by arrow (1) while holding the Pins by fingers, and then remove the Unit of 2nd/3rd Direct Frame, Both Side Cam Frame and 1st Lens Frame Unit/2nd Lens Frame Unit/3rd Lens Frame Unit from the 1st Direct Frame.

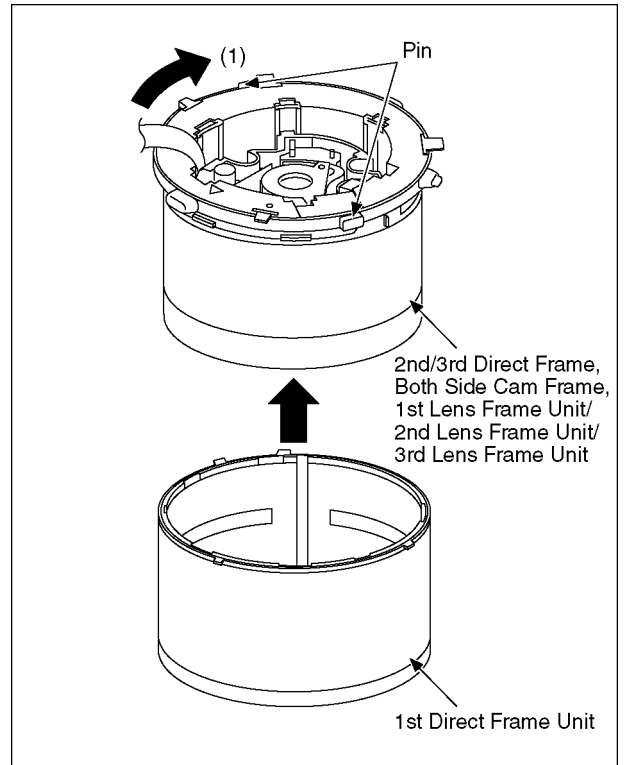

9.4.5. Removal of the 2nd/3rd Direct Frame, Both Side Cam Frame and 2nd Lens Frame Unit/3rd Lens Frame Unit

- Turn to the indicated by arrow (1) while holding the Pins by fingers, and then remove the Unit of 2nd/3rd Direct Frame, Both Side Cam Frame and 2nd Lens Frame Unit/3rd Lens Frame Unit from the 1st Lens Frame Unit.

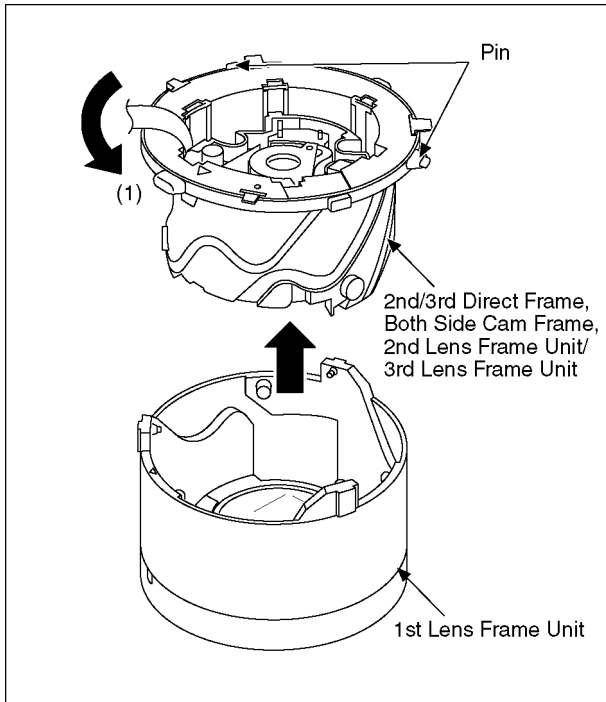

9.4.6. Removal of the 3rd Lens Frame Unit

1. Turn the 2nd/3rd Direct Frame, and then align the groove of 2nd/3rd Direct Frame.
2. Remove the 3rd Lens Frame Unit from the 2nd/3rd Direct Frame, Both Side Cam Frame and 2nd Lens Frame Unit.

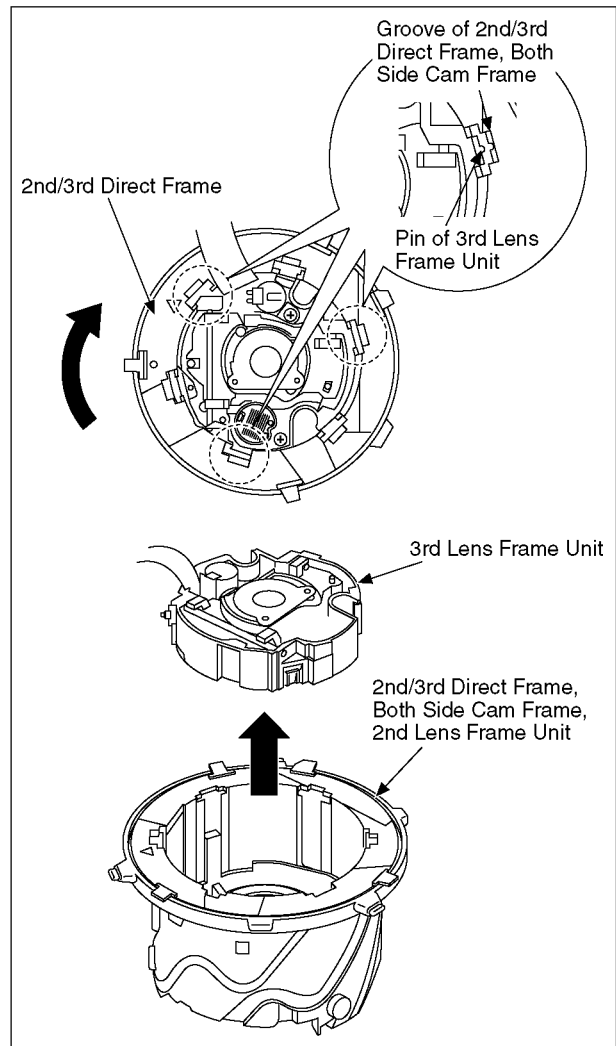

9.4.7. Removal of the 2nd Lens Frame Unit

1. Align the Δ mark to the \square mark, while turning the 2nd/3rd Direct Frame.
2. Remove the 2nd Lens Frame Unit from the 2nd/3rd Direct Frame and Both Side Cam Frame.

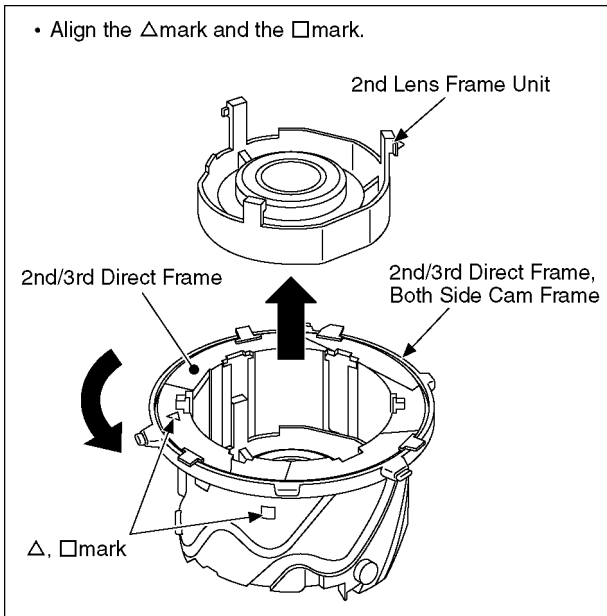

9.4.8. Removal of the 2nd/3rd Direct Frame

- While Keep pulling up the 2nd/3rd Direct Frame to the indicated by arrow (1), turn it in the indicated by arrow (2).

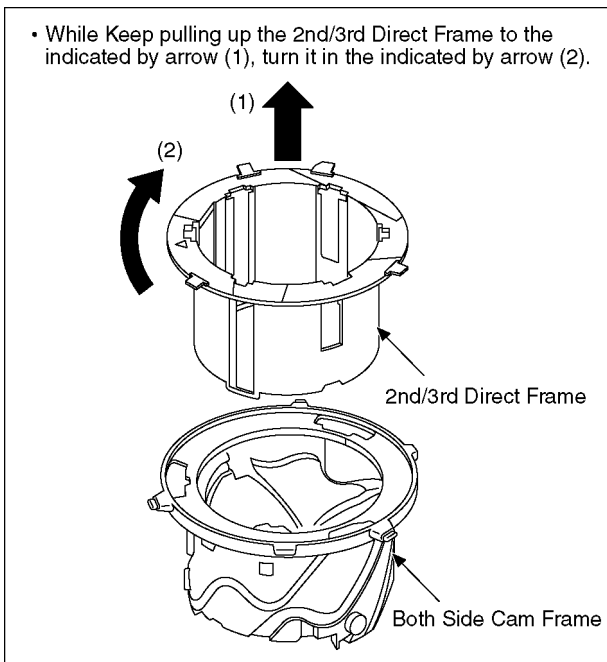

9.5. Assembly Procedure for Lens

9.5.1. Phase alignment of the 2nd/3rd Direct Frame and Both Side Cam Frame

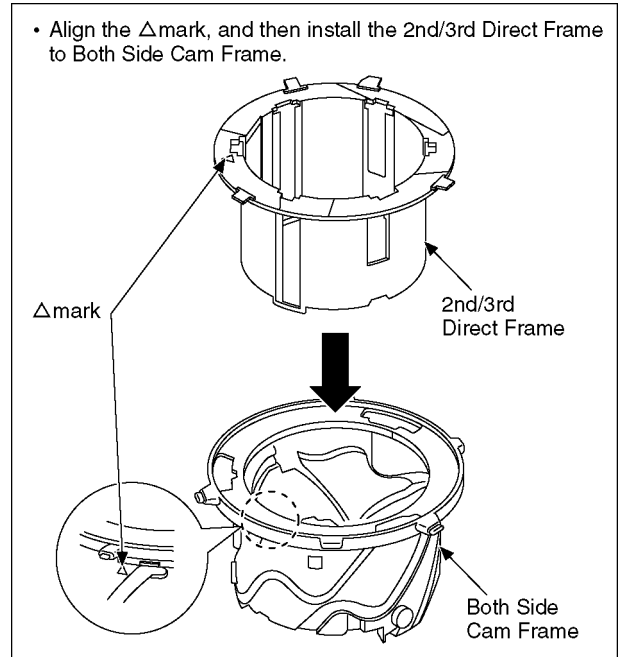

9.5.2. Assembly for the 2nd Lens Frame

1. Turn the 2nd/3rd Direct Frame to the arrow direction (1), align the Δ mark (2nd/3rd Direct Frame) and the \square mark.
2. Align the Δ mark (2nd/3rd Direct Frame and 2nd Lens Frame Unit), and then insert the 2nd Lens Frame Unit in to the 2nd/3rd Direct Frame.

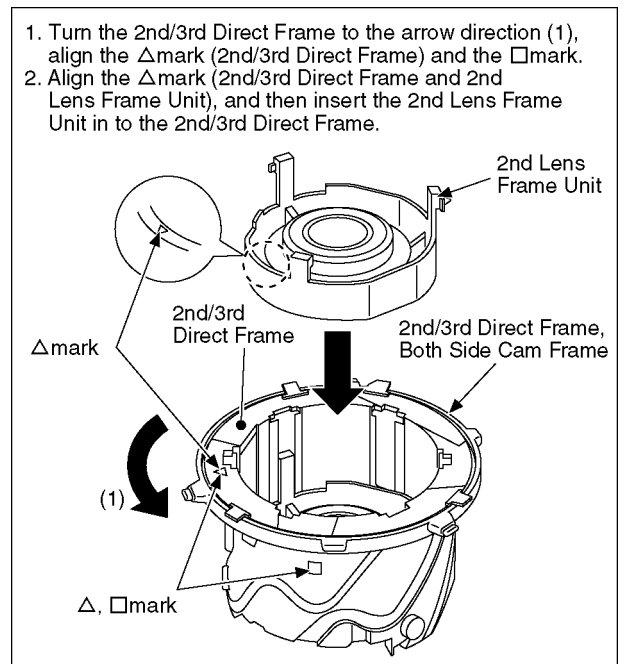

9.5.3. Assembly for and 3rd Lens Frame

1. Turn the 2nd/3rd Direct Frame to the arrow direction (1), and then align the Δ mark (2nd/3rd Direct Frame and Both Side Cam Frame).
2. Make the flex of 3rd Lens Frame Unit and Δ mark position relations of figure and then insert 3rd Lens Frame Unit to 2nd/3rd Direct Frame, Both Side Cam Frame and 2nd Lens Frame Unit.

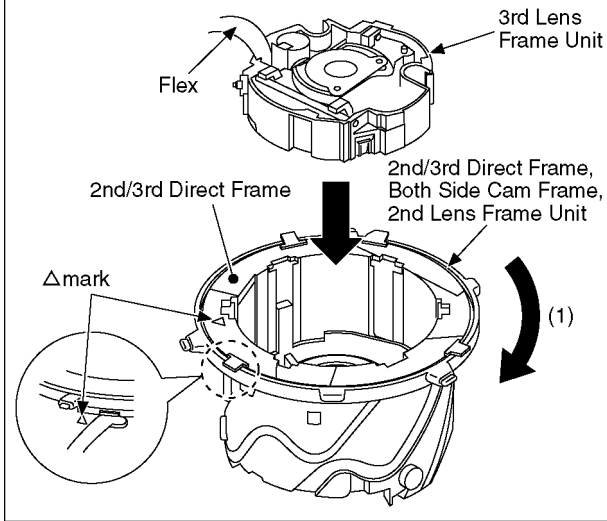

9.5.4. Assembly for the 2nd/3rd Direct Frame, Both Side Cam Frame and 2nd Lens Frame Unit/3rd Lens Frame Unit

- Align the Δ mark, and then turn 2nd/3rd Direct Frame, Both Side Cam Frame, 2nd Lens Frame Unit /3rd Lens Frame Unit to arrow direction (1), insert then in to the 1st Lens Frame Unit.

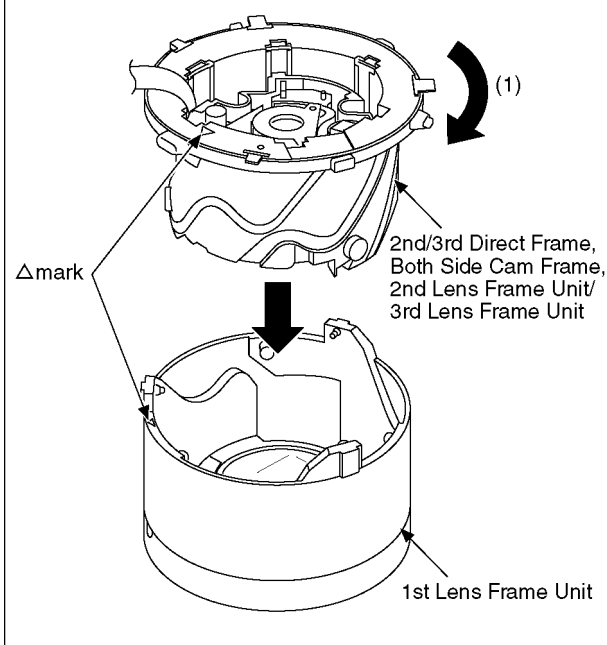

9.5.5. Assembly for the 2nd/3rd Direct Frame, Both Side Cam Frame and 1st Lens Frame Unit/2nd Lens Frame Unit/3rd Lens Frame Unit

1. Place the 1st Direct Frame Unit with its ribs positioned as below.
2. Rotate the Both Cam Frame in the arrow (1) direction and insert it as its rib (A) matches the groove (A).

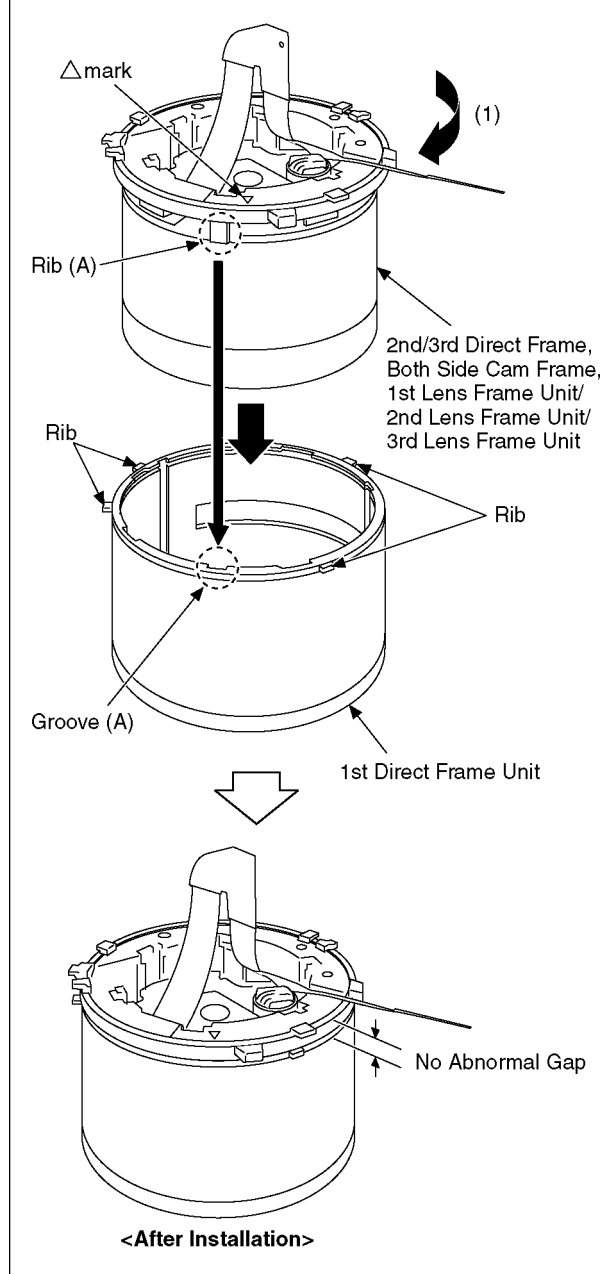

9.5.6. Assembly for the 1st Direct Frame, 2nd/3rd Direct Frame, Both Side Cam Frame and 1st Lens Frame Unit/2nd Lens Frame Unit/3rd Lens Frame Unit

1. Align the Δ mark, and then install the 1st Direct Frame, 2nd/3rd Direct Frame, Both Side Cam Frame and 1st Lens Frame Unit/ 2nd Lens Frame Unit/ 3rd lens Frame Unit to Fix Cam Frame Unit.

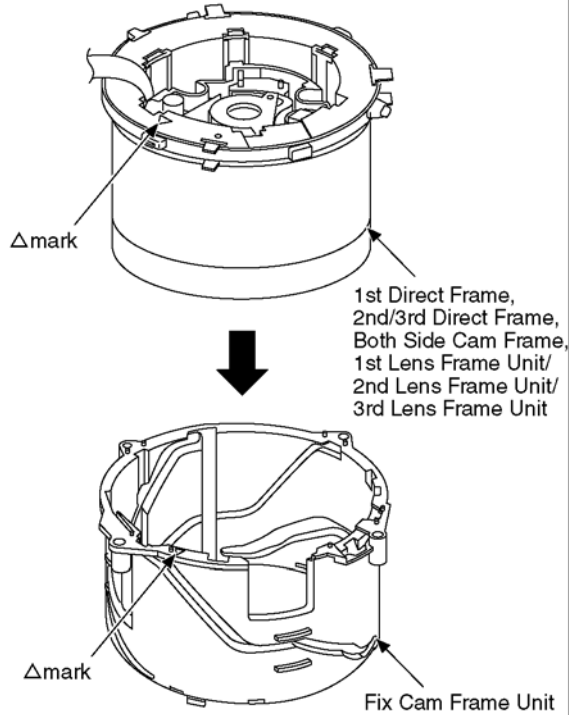

Note: (When Installing)

- Insert the flex into the Fix Cam Frame Unit.
- Take care not to damage the Flex.

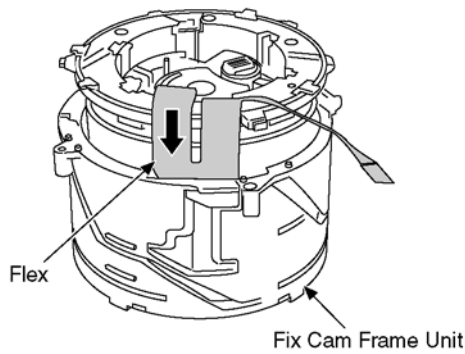

2. Turn the Both Side Cam Frame to the arrow direction (1) and then insert to groove following order.
(1)...Cam Pin of Both Side Cam Frame.
(2)...Projection of 2nd/3rd Direct Frame.

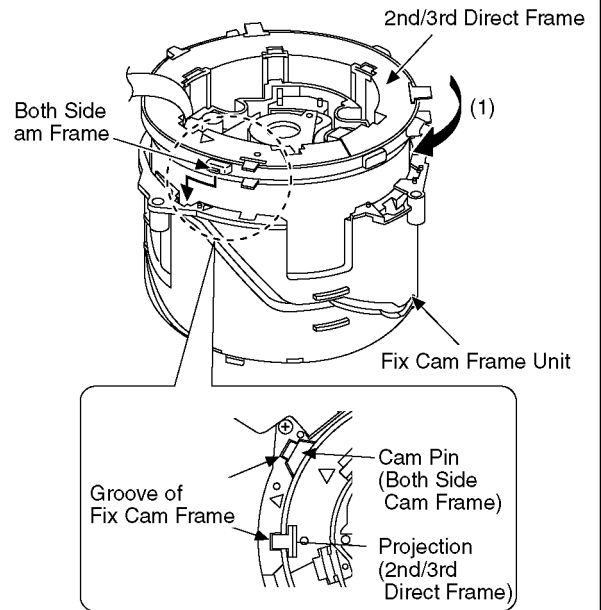

9.5.7. Assembly for the 1st Direct Frame, 2nd/3rd Direct Frame, Both Side Cam Frame, 1st Lens Frame Unit/ 2nd Lens Frame Unit/3rd Lens Frame Unit and Fix Frame Unit

- Align the Δ mark, and then install the 1st Direct Frame, 2nd/ 3rd Direct Frame, Both Side Cam Frame, 1st Lens Frame Unit/ 2nd Lens Frame Unit/ 3rd Lens Frame Unit to the Rotary Frame.

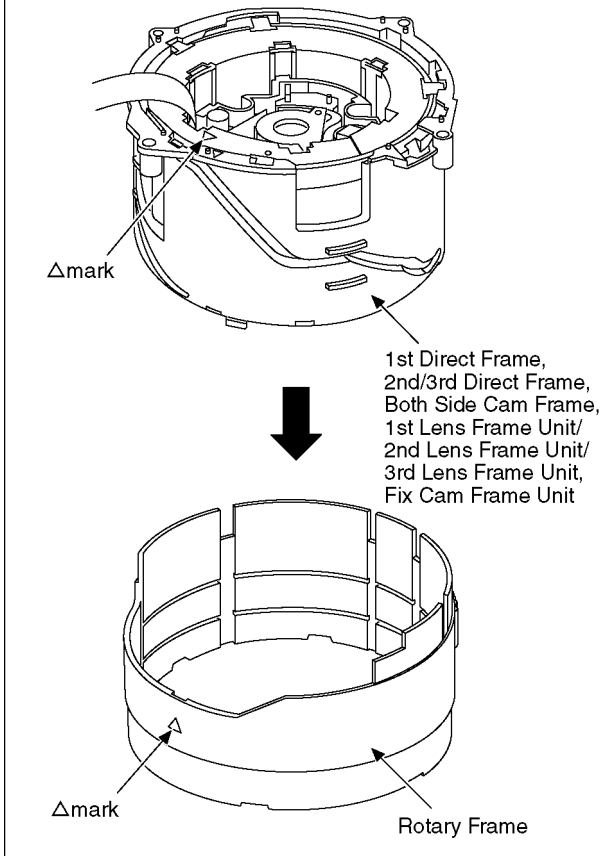

9.5.8. Assembly for the Zoom Motor Unit and Master Flange Unit

Note: (When Installing)

Refer to "The Application of Grease Method" when installing the Master Flange Unit.

- Take Care not to damage the flex.
- Take Care not to tuck in to the Master Flange Unit, when inserting the Shutter Flex.

- Screw (A) \times 4
- Screw (B) \times 2
- Shutter Flex
- Zoom Motor Flex

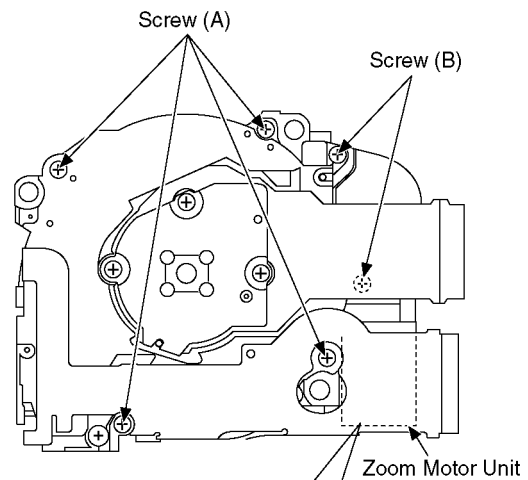
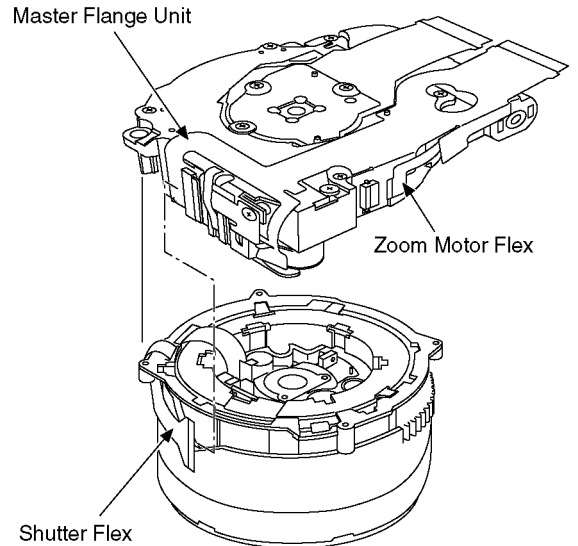

- Match the 2-holes of Zoom Motor Unit to the 2-Libs of Fix Cam Frame Unit, and then install the Zoom Motor Unit.

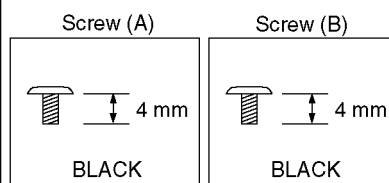
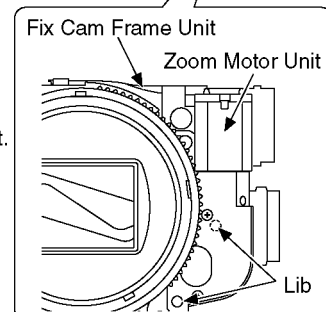

9.8. Removal of the Focus Motor Unit

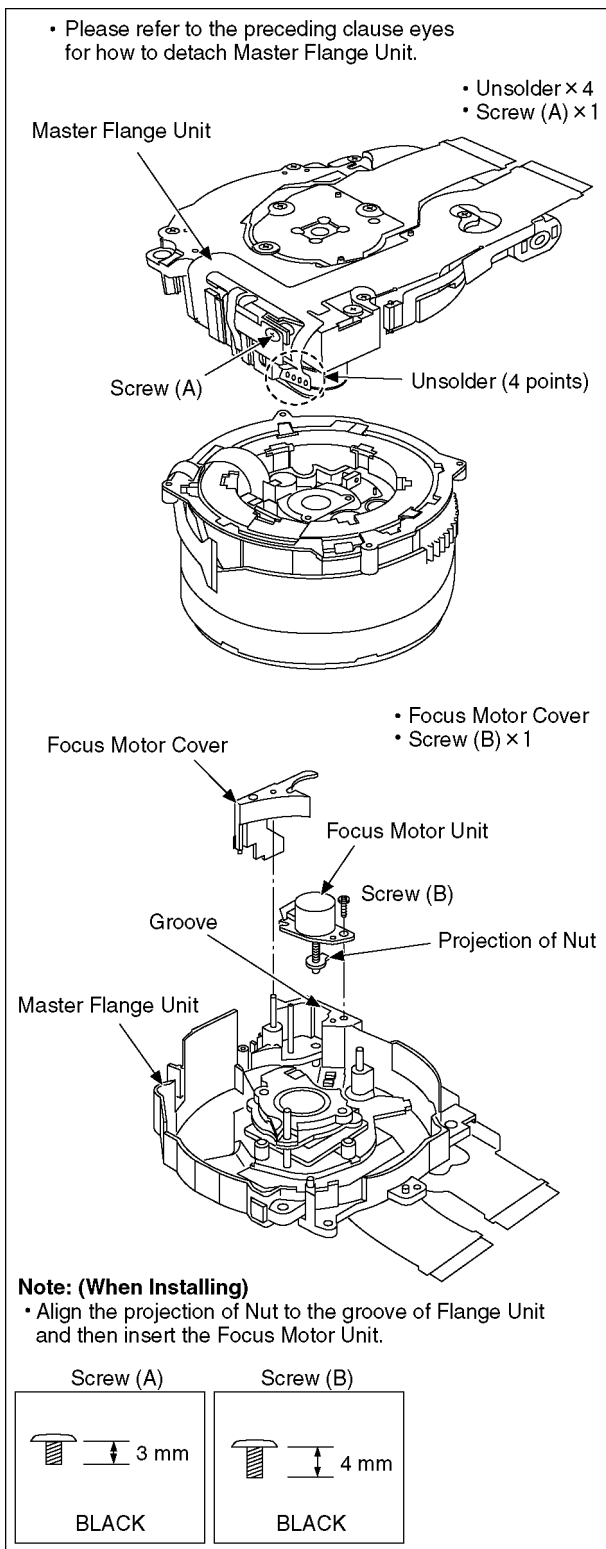

9.9. The Application of Grease Method

The grease application point of lens unit are as follows.
Apply grease additionally in the specified position if necessary.
When the grease is applied, use a toothpick and apply thinly.

- Focus motor nut moving part
 - Grease: RFKZ0472
 - Amount of apply: 2 - 4 mg
- 4th Lens Frame Unit guide pole, 5th Lens Frame Unit guide pole, Pole for positioning of Secondary Axis
 - Grease: RFKZ0472
 - Amount of apply: 0.5 - 2 mg

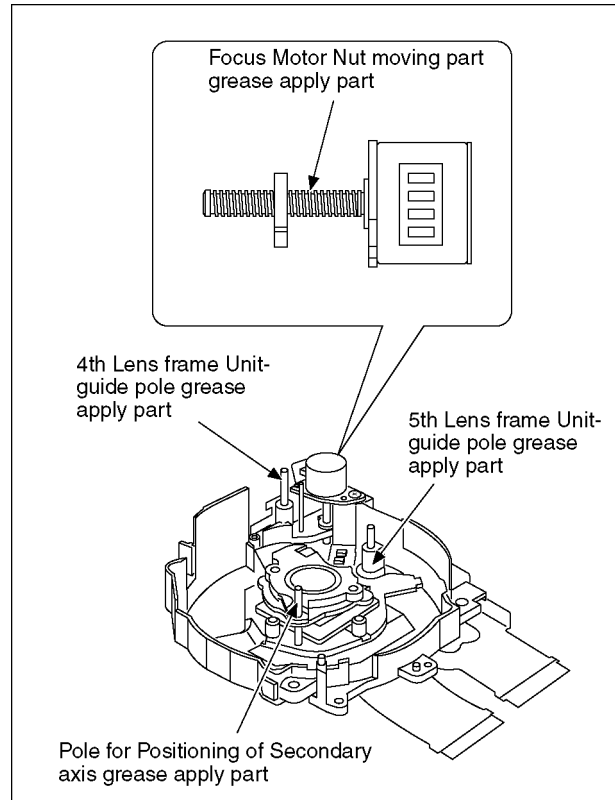

10 Measurements and Adjustments

10.1. Introduction

When servicing this unit, make sure to perform the adjustments necessary based on the part(s) replaced. Before disassembling the unit, it is recommended to back up the camera data stored in flash-rom as a data file.

IMPORTANT NOTICE (After replacing the MAIN P.C.B.)

After replacing the MAIN P.C.B., it is necessary to use the "DIAS" software to allow the release of adjustment flag(s).

The Adjustment software "DIAS" is available at "TSN Website". To download, click on "Support Information from NWBG/VDBG-AVC".

*DIAS (DSC Integrated Assist Software)

10.2. Before Disassembling the unit

10.2.1. Initial Setting Release

The cameras specification are initially set in accordance with model suffix (such as EB, EG, GK, GC, and so on.).

Unless the initial setting is not released, an automatic alignment software in the camera is not able to be executed when the alignment is carried out.

Note:

The initial setting should be again done after completing the alignment. Otherwise, the camera may not work properly.

Therefore as a warning, the camera display a warning symbol " ! " on the LCD monitor every time the camera is turned off.

Refer to the procedure described in "3.4.2. INITIAL SETTINGS" for details.

[How to Release the camera initial setting]

Preparation:

Attach the Battery or AC Adaptor with a DC coupler to the unit.

Set the recording mode dial to PROGRAM AE mode.

Step 1. Temporary cancellation of "INITIAL SETTINGS":

Set the REC/PLAYBACK selector switch to "REC" (Camera mark).

While pressing the UP of Cursor button and MOTION PICTURE button simultaneously, turn the power switch to the ON position.

Step 2. Cancellation of "INITIAL SETTINGS":

Set the REC/PLAYBACK selector switch to "PLAYBACK".

While pressing UP of Cursor button and MOTION PICTURE button simultaneously. (The camera will beep after this.)

Turn the Power off. (The warning symbol " ! " is displayed on the LCD monitor.)

10.2.2. Flash-Rom Data Backup

When trouble occurs, it is recommended to backup the Flash-rom data before disassembling the unit. There are two kinds of Flash-rom data backup methods:

[ROM_BACKUP (Method of Non-PC backup)]

1. Insert the SD-card into the camera.
2. Set the camera to "Temporary cancellation of the initial settings".
3. Select the "SETUP" menu.
From the "SETUP" menu, select "ROM BACKUP".

Note:

This item is not listed on the customer's "SET UP" menu.

4. When this "ROM_BACKUP" item is selected, the following submenus are displayed.

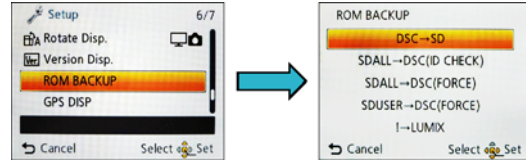

Item	Function	Details
DSC → SD	Save all the DSC's Flash-rom data to SD-CARD	<ul style="list-style-type: none"> DSC's Flash-rom data is saved to the SD-CARD as a data file by the same format as the TATSUJIN software for the previous models. (DATA BACKUP) -File location: ROOT DIRECTORY in SD-CARD. -File Name: <ol style="list-style-type: none"> 1) User Setup Information data : <Model Number>U.txt [Example: DMC-FX66 : "FX66U.txt"] 2) Optical Adjustment data : <Model Number>F.txt [Example: DMC-FX66 : "FX66F.txt"] If the concerned file already exists, "OVERWRITE?" message is displayed.
SDALL → DSC (ID CHECK)	Write the all data to DSC's Flash-rom from SD-CARD	<ul style="list-style-type: none"> The backup data being stored in the SD card is transferred to DSC unit. ID CHECK: When the model ID is different, data is not transferred. FORCE: Even if the model ID is different, data is transferred. * If the main PCB is replaced, select "SDALL → DSC (FORCE)".
SDALL → DSC (FORCE)	Write the all data to DSC's Flash-rom from SD-CARD	
SDUSER → DSC (FORCE)	Only "User setup information" is written from the saved file in the SD-CARD to DSC's Flash-rom.	<ul style="list-style-type: none"> Only the user's "setup" setting condition is transferred to DSC unit. FORCE: Even if the model ID is different, the data is transferred.
! → LUMIX	Shipping set without initializing "User setup information"	<ul style="list-style-type: none"> Initial setting is executed without initializing the user's set up setting condition. * The initial setting must be perform while the Self-timer LED is blinking, * The picture data stored in the built-in memory of the DSC is not erased, with this operation.

[DSC Integrated Assist Software (Method of Using PC)]

Same as TATSUJIN software for previous models.

10.2.3. Light Box

If using VFK1164TDVLB Light Box, remove the lens connection ring by loosening three hexagon screws.

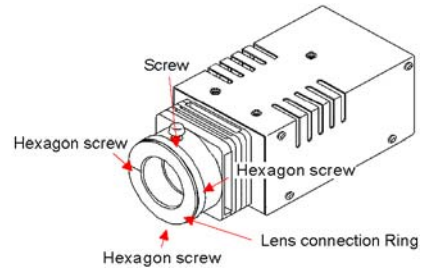

10.3. Details of Electrical Adjustment

10.3.1. How to execute the Electrical Adjustment

It is not necessary to connect the camera to a PC to perform adjustments.

"Flag reset operation" and "Initial setting operation" are required when carrying out the alignment, follow the procedure below.

10.3.1.1. Startup Electrical Adjustment mode

1. Release the initial settings.
2. Insert a recordable SD card.
(Without a SD card, the automatic adjustment can not executed.)
3. Procedure to set the camera into adjustment mode:
 - a. Set the mode into PROGRAM AE mode.
 - b. Set the REC/PLAYBACK selector switch to "REC" (Camera mark).
 - c. Turn the Power SW off.
 - d. Turn the Power SW on pressing MOTION PICTURE and Menu simultaneously.
LCD monitor displays "SERVICE MODE".
(Refer to Fig.F3-1)



Fig. 3-1

10.3.1.2. Status Adjustment Flag Setting

Reset (Not yet adjusted) the status flag condition.

1. After pressing the DISPLAY button, the LCD monitor displays the Flag status screen (Refer to Fig.3-2.)
2. Select item by pressing the cross keys. (Gray cursor is moved accordingly.)
3. Press the DELETE button.

Note:

The selected item's flag has been changed from "F (green)" to "0 (yellow)".

*(Refer to Fig. 3-3)

*Flag conditions:

F (green)

means that the alignment has been completed and the status flag condition is set. In this case, the flag condition should be reset, if you try to carry out the automatic alignment.

0 (yellow)

means that the alignment has been not "completed" and the status flag condition is "reset". In this case, automatic alignment is available.

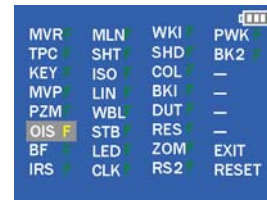

Fig. 3-2



Fig. 3-3

- In case of setting the status flag into set condition again without completion of the alignment, the status flag should be SET by using PC, or UNDO by using ROM BACKUP function.

10.3.1.3. Execute Adjustment

1. Perform step "10.3.1.1." to "10.3.1.2.", to reset the OIS flag status "F" (Set) to "0" (Reset).
2. Press DISPLAY button after Flag reset.
OIS Adjustment screen is displayed on the LCD panel.
(Refer to Fig.3-4)
3. Press the shutter button. The adjustment will start automatically.
4. When the adjustment is completed successfully, adjustment report menu appears with Green OK on the LCD monitor. (Refer to Fig.3-5)

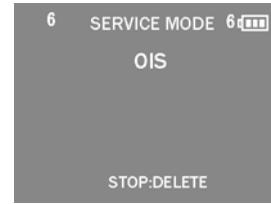

Fig. 3-4



Fig. 3-5

10.3.1.4. Attention point during Adjustment

1. Step "10.3.1.3." procedure shows OIS adjustment as an example. To perform the adjustment, refer to the "10.3.2. Adjustment Specifications" table which shows key point for each adjustment.
2. Do not move the light box, the camera or the chart while adjusting. If one of these is moved accidentally, start the adjustment again.
3. Do not press any buttons/keys until the default menu (Fig.3-6) is displayed on the LCD monitor. Otherwise, adjustment data may not be stored properly.
4. If the adjustment is interrupted accidentally, the alignment data may not be properly saved in the Flash-rom.



Fig. 3-6

10.3.1.5. Finalizing the Adjustment

1. Several adjustment flags can be reset ("F" into "0") at the same time. In this case, when the adjustment has been completed, the screen will change showing the adjustment for the next item until all reset items are completed.
Also, when the shutter button is pressed, the screen jump to the next adjustment item.
2. To cancel the adjustment mode while in the process of performing the adjustment, follow this procedures.
 - (1) Press DELETE button.
 - (2) Press "Right of cross key" button.

Note:

- *.If adjustment is cancelled with above procedure, adjustment is not completed. Make sure to adjust it later.
- *.Adjustment software "DIAS" is able to control the status of the adjustment flags.

10.3.2. Adjustment Specifications

The following matrix table shows the relation between the replaced part and the Necessary Adjustment. When a part is replaced, make sure to perform the necessary adjustment(s) in the order indicated. The table below shows all the information necessary to perform each adjustment.

Adjustment order	Adjustment Item	FLAG	Purpose	Replacing Parts							JIG/TOOLS	SET UP	How to Operate		
				MAIN PCB	VENUS FHD (IC6001)	MCP (IC6002)	Lens Parts (except C-MOS)	C-MOS Unit	T-PANEL DRIVER (IC9301)	TOUCH PANEL				GYRO (IC3701/IC7301)	
1	Touch Panel Control	TPC	Touch Panel Inspection	○	○	○	○	○	○	○	○	○	Touch Pen	NONE	1) Touch sequentially "+" mark displayed on the LCD with the touch pen. 2) After completed, the "OK" menu appears.
1	Venus Zoom	PZM	Venus Zoom Inspection	○	○	○	○	○	○	○	○	○	NONE	NONE	1) Press Shutter Button. 2) After completed, the "OK" menu appears.
2	OIS sensor	OIS	OIS sensor output level adjustment	○	○	○	○	○	○	○	○	○	NONE	NONE	1) Press Shutter Button (Do not apply any shock and vibration for the camera while adjusting) 2) After completed, the "OK" menu appears.
3	Backfocus / GYRO	BF	To have the focus tracking curve be appropriate shape and GYRO sensor adjustment	○	○	○	○	○	○	○	○	○	<ul style="list-style-type: none"> • COLLIMATOR (VFK1164TCM02 or VFK1164TCM03 or RFKZ0422) 	1) Set the camera in front of collimator so that the distance from collimator to camera becomes about 6.3 cm as shown in Fig.A. 2) Set the camera angle so that the center of the chart comes to the center of the LCD monitor. [IMPORTANT] The adjustment "NG" might be happened with the following conditions: - Do not put the black colored stuff at the back side of collimator near hunching chart. It needs to get some certain brightness. - Make sure the hunching chart has no dust and dirty condition. - Do not connect a USB cable during adjustment.	1) Press Shutter Button (Do not apply any shock and vibration for the camera while adjusting) 2) After completed, the "OK" menu appears.
4	Iris	IRS	Iris adjustment	○	○	○	○	○	○	○	○	○	<ul style="list-style-type: none"> • LIGHT BOX (VFK1164TDVLB or RFKZ0523) 	1) Set the camera in front of LIGHT BOX so that the distance from LIGHT BOX to camera becomes about 8 cm as shown in Fig.B. 2) Aim the LIGHTBOX so that the entire LCD screen becomes fully "white". (No dark area).	1) Press Shutter Button 2) After completed, the "OK" menu appears.
5	Monitor Linearity	MLN	Monitor Linearity adjustment	○	○	○	○	○	○	○	○	○			1) Press Shutter Button 2) After completed, the "OK" menu appears.
6	Shutter	SHT	Shutter speed adjustment	○	○	○	○	○	○	○	○	○		1) Insert the TR chart into the slot of LIGHT BOX. 2) Set the camera in front of LIGHT BOX so that the distance from LIGHT BOX to camera becomes about 12 cm as shown in Fig.B. 3) Set the camera angle so that the color chart is displayed on the LCD monitor fully. [IMPORTANT] The adjustment "NG" might be happened with the following conditions: - Since the lens position is automatically set into certain position after executing auto adjustment, confirm the angle after stopping the lens zoom position. - It is no problem even though the chart on to the LCD monitor slightly cut at the corner.	1) Press Shutter Button 2) After completed, the "OK" menu appears.
7	ISO	ISO	ISO sensitivity adjustment	○	○	○	○	○	○	○	○	○			1) Press Shutter Button 2) After completed, the "OK" menu appears.
8	High brightness coloration	LIN	High brightness coloration adjustment	○	○	○	○	○	○	○	○	○	<ul style="list-style-type: none"> • LIGHT BOX (VFK1164TDVLB or RFKZ0523) • TR CHART (RFKZ0443) 	- It is no problem even though the chart on to the LCD monitor slightly cut at the corner. - It is no problem even though the focusing slightly becomes out of focusing condition. - Not connect the USB cable at this stage.	1) Press Shutter Button 2) After completed, the "OK" menu appears.
9	White Balance	WBL	White balance adjustment under various color temperature	○	○	○	○	○	○	○	○	○			1) Press Shutter Button 2) After completed, the "OK" menu appears.
10	CCD Missing Pixels (White)	WKI	Compensation of CCD Missing Pixels (White)	○	○	○	○	○	○	○	○	○	NONE	NONE	1) Press Shutter Button 2) After completed, the "OK" menu appears.
11	Color reproduction inspection and Microphone check	COL	Color reproduction inspection and Microphone check	○	○	○	○	○	○	○	○	○	NONE	Right after pressing the shutter button, enter the continuous sounds (voice) to the microphone until lens unit starting the zooming.	1) Press Shutter Button. Right after pressing the shutter button, make a continuous sound (voice) to the microphone until lens unit starting the zooming. 2) After completed, the "OK" menu appears.
		BK1	Do not use "BK1" adjustment flag for this unit. Use "BK2" adjustment flag, instead. (In case of most DSC models, the adjustment flag for CCD Missing Pixels is "BK1". But, in this model, "BK2" the adjustment flag for CCD Missing Pixels.)												
12	CCD Missing Pixels (Black)	BK2	Compensation of CCD Missing Pixels (Black)	○	○	○	○	○	○	○	○	○	<ul style="list-style-type: none"> • LIGHT BOX (VFK1164TDVLB) • ND FILTER (VFK1164ND15) 	1) Prepare the LIGHTBOX (RFKZ0523). (The LIGHTBOX "VFK1164TDVLB" can be used if the front hood of VFK1164TDVLB is removed.) 2) Set the ND Filter (VFK1164ND15) to the LIGHTBOX. 3) Set the LIGHTBOX and Camera unit so that distance becomes about 3.5 cm. (Fig.B) NOTE: Do not use "BK1" adjustment flag for this unit. Use "BK2" adjustment flag, instead.	1) Set the LIGHTBOX and Camera unit so that the distance becomes about 3.5 cm. (Refer to Fig.B) 2) Press the Shutter Button. (The green●mark is displayed on LCD.) 3) Aim the LIGHTBOX and make the frame detail alignment so that the entire LCD screen becomes fully "white". (No dark area). 4) Press Shutter Button. (The adjustment is executed, and then green●mark is displayed on LCD.) 5) Set the LIGHTBOX and Camera unit so that the distance becomes about 4.0 cm. (Refer to Fig.B) 6) Press Shutter Button. (The green●mark is displayed on LCD.) 7) Press Shutter Button. (The adjustment is executed, and then green●mark is displayed on LCD.) 8) Set the LIGHTBOX and Camera unit so that the distance becomes about 5.2 cm. (Refer to Fig.B) 9) Press Shutter Button. (The green●mark is displayed on LCD.) 10) Press Shutter Button. (The adjustment is executed, then "OK" mark is displayed on LCD when the adjustment has been completed successfully.)

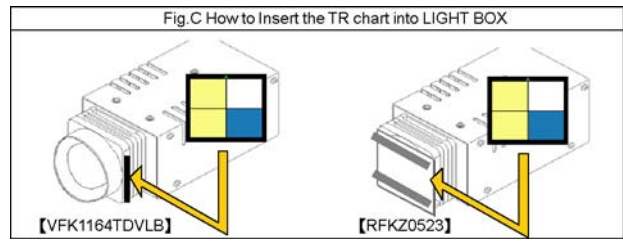
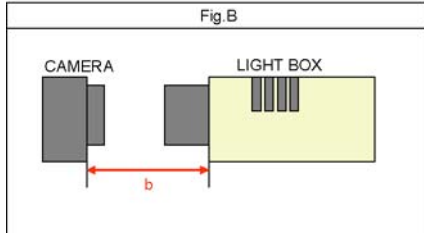
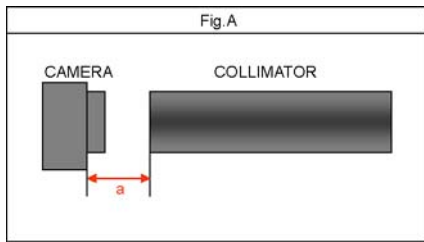

n IMPORTANT NOTICE (After replacing the MAIN P.C.B.)

After replacing the MAIN P.C.B., make sure to perform the "INITIAL SETTINGS" first, then release the "INITIAL SETTINGS" in order to proceed the electrical adjustment.

Note:

1. If electrical adjustment or data re-writing is executed before "INITIAL SETTINGS", suffix code list is never displayed, and it cannot be chosen suitable suffix code.
2. Never remove the battery during initial setting in process.

10.4. After Adjustment

10.4.1. Initial Setting

Since the initial setting has been released to execute the built-in adjustment software, it should be set up again before shipping the camera to the customer.

Refer to the procedure described in "3.4.2. INITIAL SETTINGS" for details.

[IMPORTANT]

1. The initial setting should be done again after completing the alignment. Otherwise, the camera will not work properly.
Therefore as a warning, the camera display a warning symbol " ! " on the LCD monitor every time the camera is turned off.
2. Confirm that status of all adjustment flag show "F". Even if one of the adjustment flag shows "0", initial setting programmed is never executed.
3. Adjustment software "DIAS" is able to control the status of the adjustment flags.
The Adjustment software "DIAS" is available at "TSN Website", therefore, access to "TSN Website" at "Support Information from NWBG/VDBG-AVC".

11 Maintenance

11.1. Cleaning Lens, Viewfinder and LCD Panel

Do not touch the surface of lens, Viewfinder and LCD Panel with your hand.

When cleaning the lens, use air-Blower to blow off the dust.

When cleaning the LCD Panel, dampen the lens cleaning paper with lens cleaner, and the gently wipe the their surface.

Note:

The Lens Cleaning KIT; VFK1900BK(Only supplied as 10 set/Box) is available as Service Aid.

Service Manual

Diagrams and Replacement Parts List

Digital Camera

Model No.

DMC-TZ20EB	DMC-TZ20GN	DMC-ZS10GH
DMC-TZ20EE	DMC-TZ20SG	DMC-ZS10GK
DMC-TZ20EF	DMC-ZS10P	DMC-ZS10GT
DMC-TZ20EG	DMC-ZS10PC	
DMC-TZ20EP	DMC-ZS10PU	
DMC-TZ20GC	DMC-ZS10GD	

Vol. 1

Colour

(S).....Silver Type (except DMC-TZ20EF, ZS10PC/GD)

(K).....Black Type

(A).....Blue Type (only DMC-TZ20EB/EE/EG/EP/GN, ZS10P/PC)

(R).....Red Type (except DMC-ZS10GD/GH/GT)

(T).....Brown Type (only DMC-TZ20EE/EF/EG/EP/GC/GN, ZS10P/GK/GT)

(N).....Gold Type (only DMC-TZ20SG, ZS10GK)

Table of contents

S1. About Indication of The Schematic Diagram.....	S-1	S5. Print Circuit Board.....	S-9
S1.1. Important Safety Notice.....	S-1	S5.1. Flash P.C.B.	S-9
S2. Voltage Chart	S-2	S5.2. Top Operation P.C.B.....	S-10
S2.1. Flash P.C.B.	S-2	S5.3. SD P.C.B.	S-11
S2.2. Top Operation P.C.B.....	S-2	S5.4. Gyro P.C.B.	S-12
S2.3. Gyro P.C.B.	S-2	S5.5. Lens Flex P.C.B.....	S-13
S3. Block Diagram.....	S-3	S6. Replacement Parts List.....	S-15
S3.1. Overall Block Diagram	S-3	S7. Exploded View	S-20
S4. Schematic Diagram.....	S-4	S7.1. Frame and Casing Section.....	S-20
S4.1. Interconnection Diagram.....	S-4	S7.2. Packing Parts and Accessories Section (1)	S-21
S4.2. Flash Schematic Diagram.....	S-5	S7.3. Packing Parts and Accessories Section (2)	S-22
S4.3. Top Operation Schematic Diagram	S-6		
S4.4. SD Card Schematic Diagram.....	S-7		
S4.5. Gyro Schematic Diagram.....	S-7		
S4.6. Lens Flex Schematic Diagram	S-8		

S1. About Indication of The Schematic Diagram

S1.1. Important Safety Notice

COMPONENTS IDENTIFIED WITH THE MARK \triangle HAVE THE SPECIAL CHARACTERISTICS FOR SAFETY. WHEN REPLACING ANY OF THESE COMPONENTS USE ONLY THE SAME TYPE.

1. Although reference number of the parts is indicated on the P.C.B. drawing and/or schematic diagrams, it is NOT mounted on the P.C.B. when it is displayed with "\$" mark.
2. It is only the "Test Round" and no terminal (Pin) is available on the P.C.B. when the TP (Test Point) indicated as "●" mark.
3. The voltage being indicated on the schematic diagram is measured in "Standard-Playback" mode when there is no specify mode is mentioned.
4. Although the voltage and waveform available on here is measured with standard frame, it may be differ from actual measurement due to modification of circuit and so on.
5. The voltage being indicated here may be include observational-error (deviation) due to internal-resistance and/or reactance of equipment. Therefore, handle the value indicated on here as reference.
6. Use the parts number indicated on the Replacement Parts List .
7. Indication on Schematic diagrams:

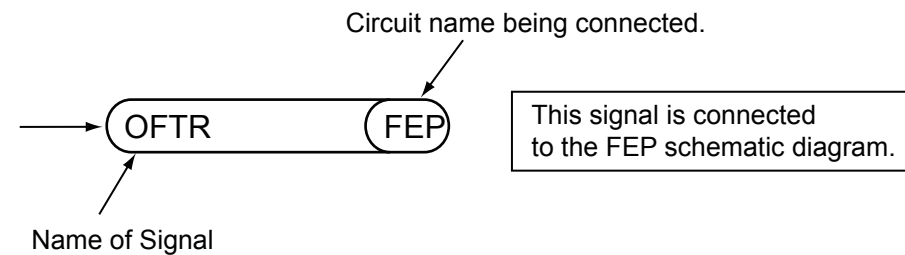

S2. Voltage Chart

Note) Indicated voltage values are the standard values for the unit measured by the DC electronic circuit tester (high-impedance) with the chassis taken as standard.
Therefore, there may exist some errors in the voltage values, depending on the internal impedance of the DC circuit tester.

S2.1. Flash P.C.B.

REF No.	PIN No.	POWER ON
IC8101	1	0
IC8101	2	0
IC8101	3	0
IC8101	4	0
IC8101	5	3.6
IC8101	6	0
IC8101	7	0
IC8101	8	0
IC8101	9	3.1
IC8101	10	4.4

S2.2. Top Operation P.C.B.

REF No.	PIN No.	POWER ON
IC7310	1	-
IC7310	2	-
IC7310	3	-
IC7310	4	0
IC7310	5	1.4
IC7310	6	1.4
IC7310	7	0
IC7310	8	3.1

S2.3. Gyro P.C.B.

REF No.	PIN No.	POWER ON
IC9701	1	-
IC9701	2	-
IC9701	3	-
IC9701	4	0
IC9701	5	1.4
IC9701	6	1.4
IC9701	7	0
IC9701	8	3.1

S3. Block Diagram

S3.1. Overall Block Diagram

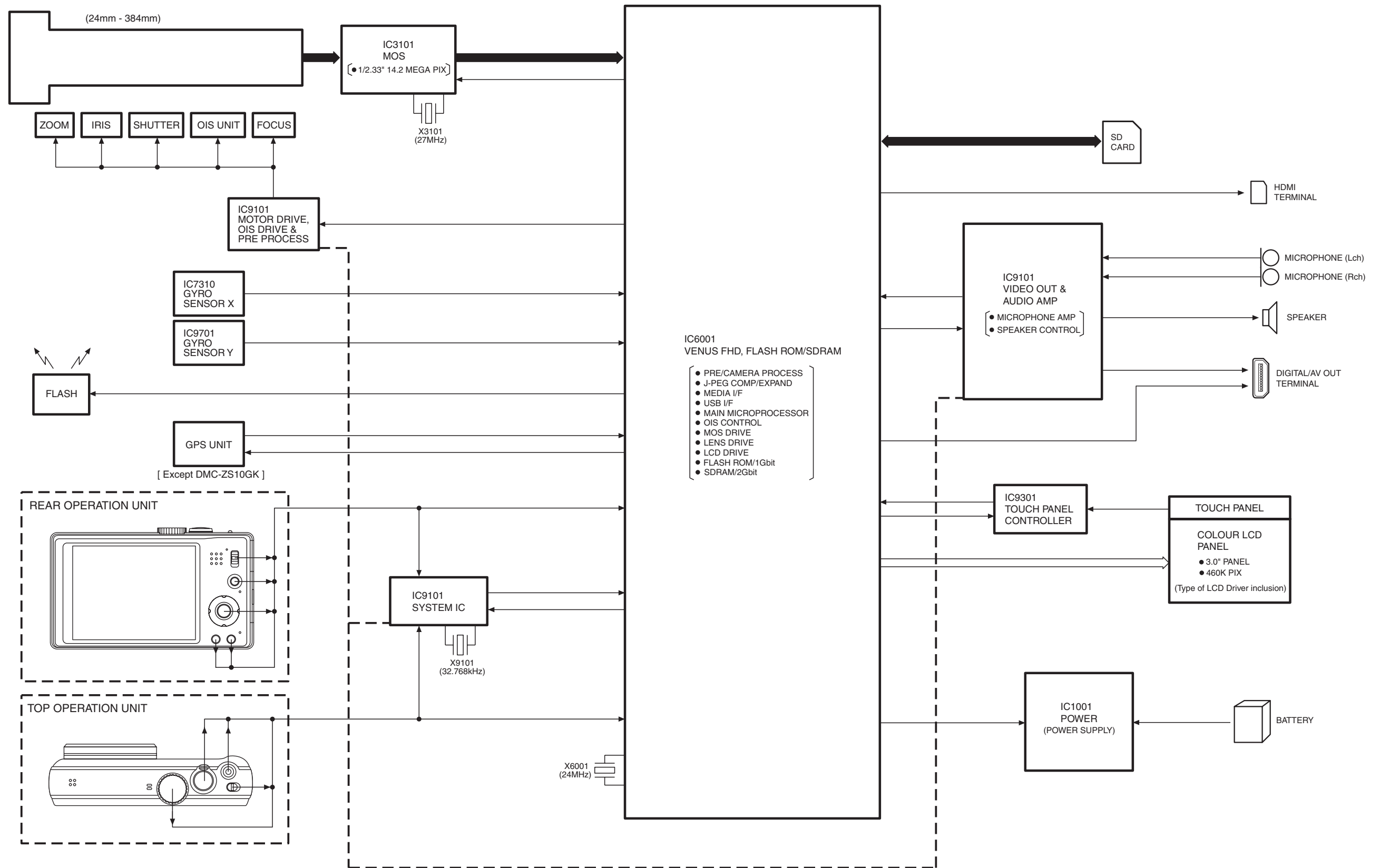

S4. Schematic Diagram

S4.1. Interconnection Diagram

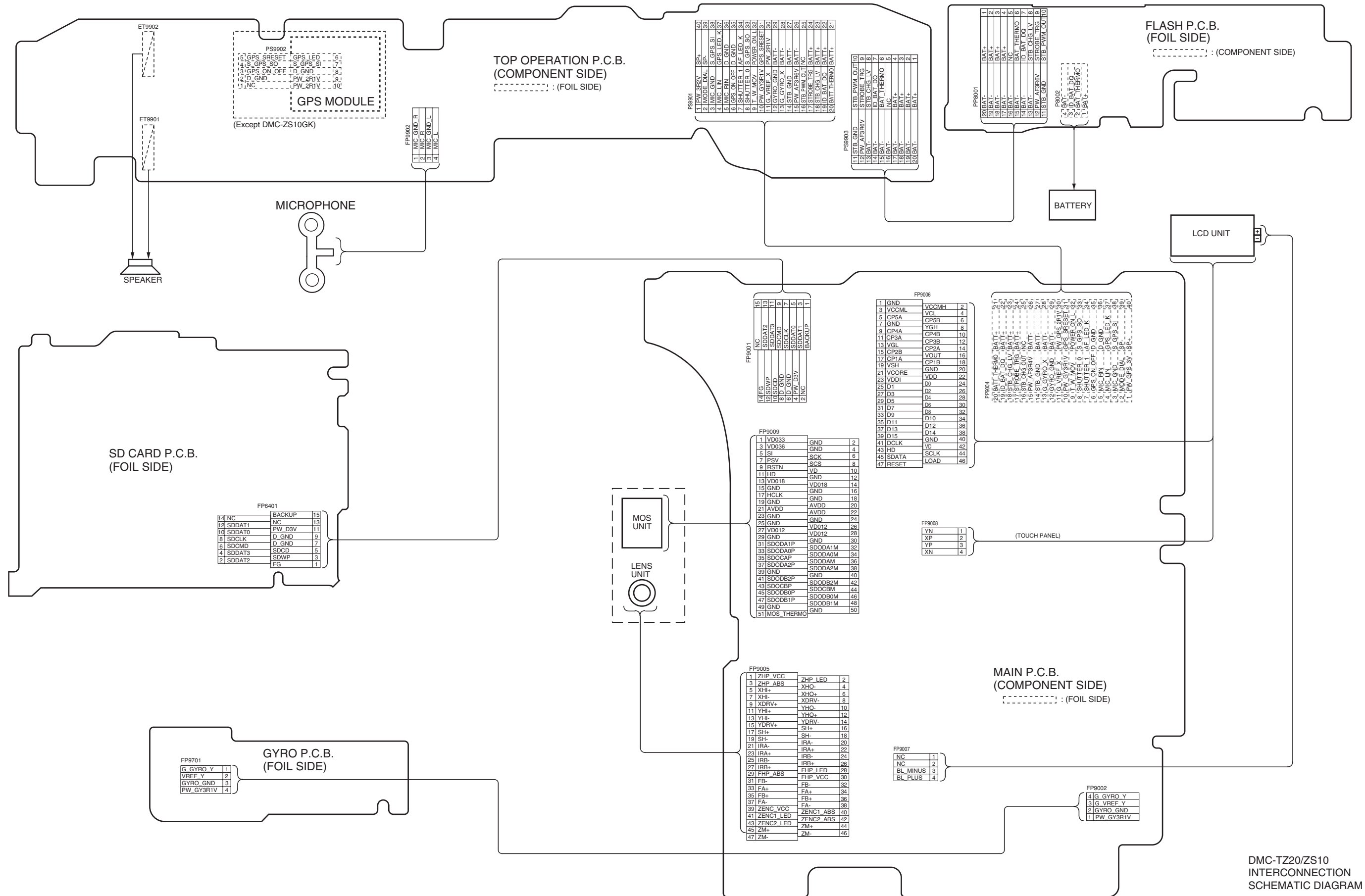

DMC-TZ20/ZS10 INTERCONNECTION SCHEMATIC DIAGRAM

S4.2. Flash Schematic Diagram

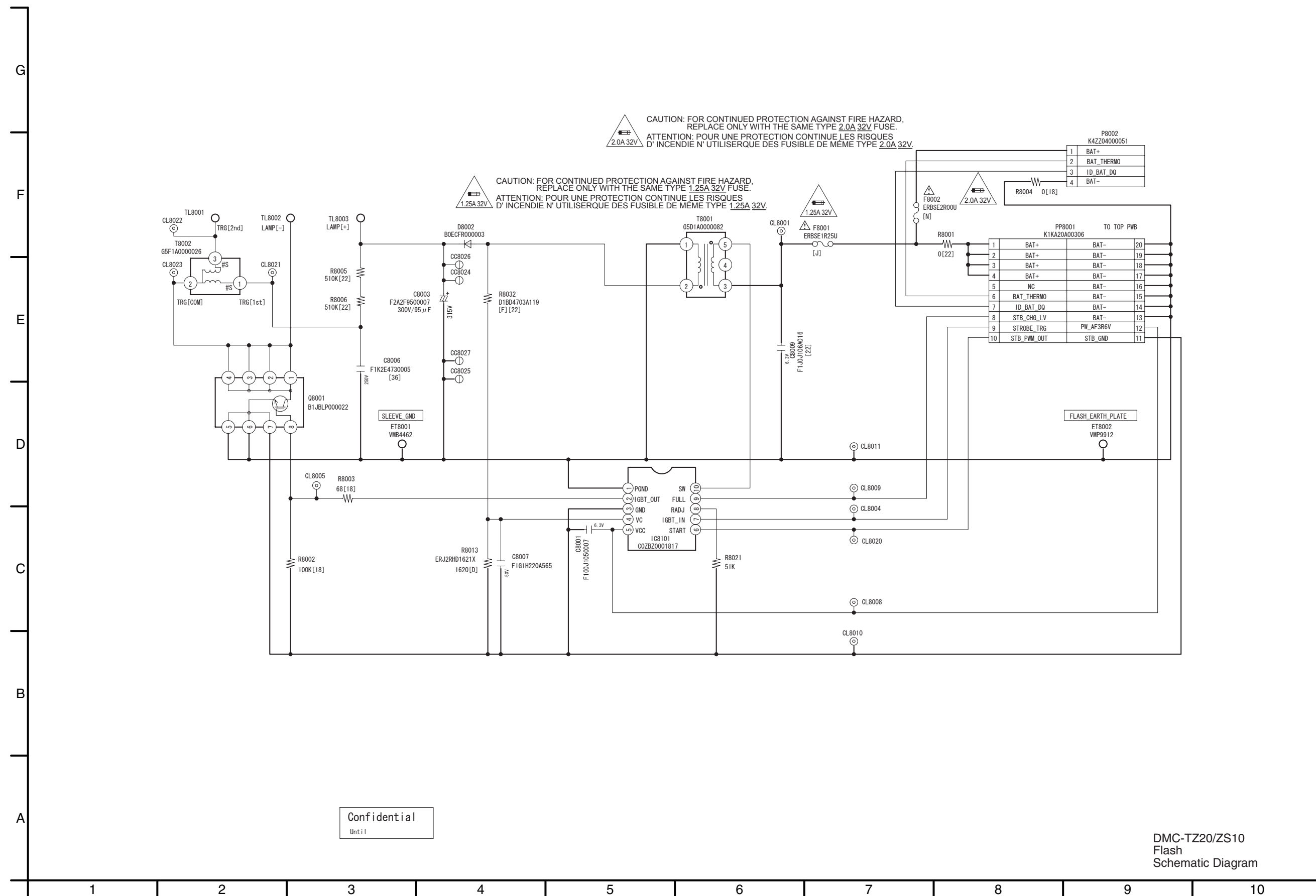

Confidential
Until

S4.3. Top Operation Schematic Diagram

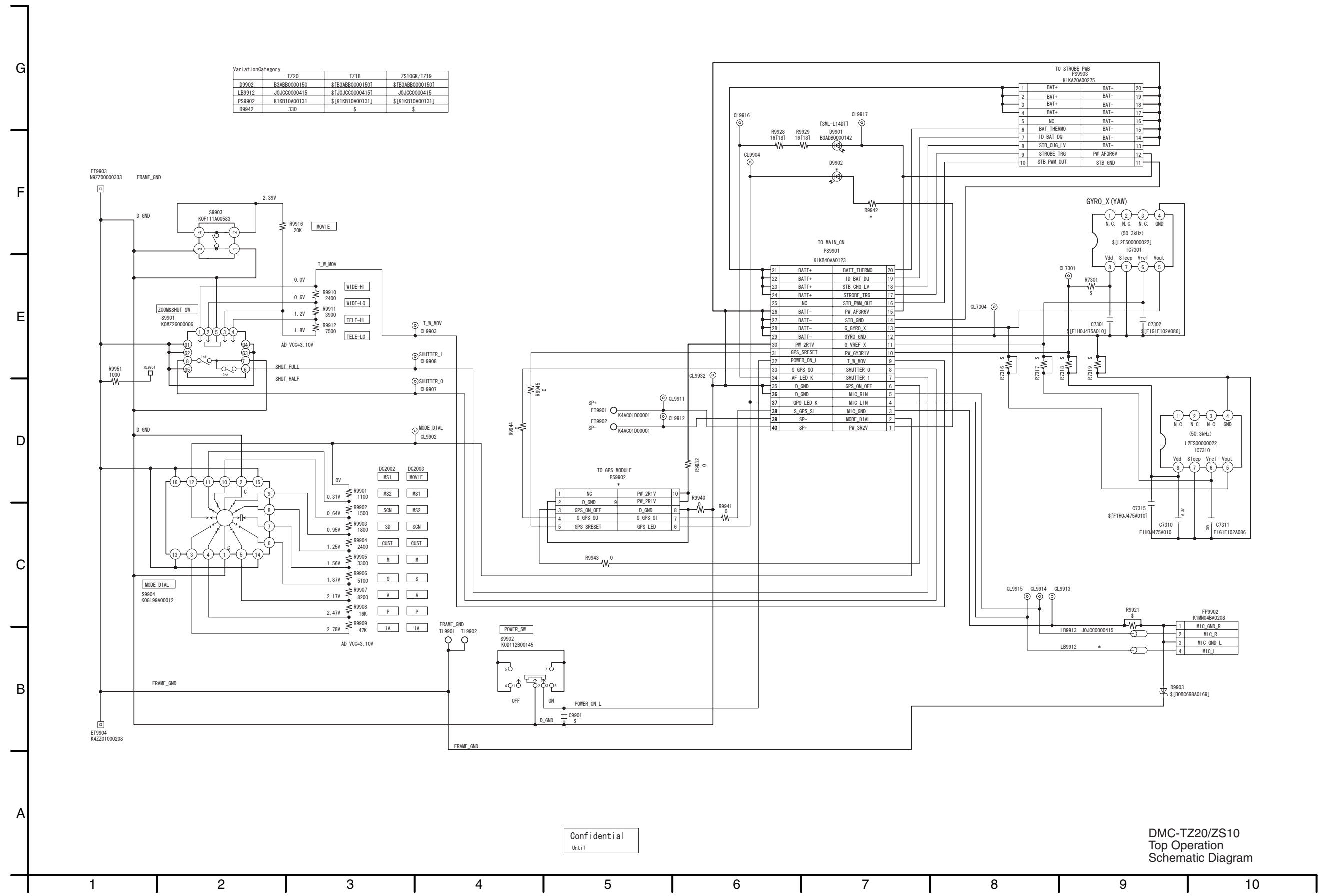

Variation Category	TZ20	TZ18	ZS109K/TZ19
D9902	B3ABB0000150	\$(B3ABB0000150)	\$(B3ABB0000150)
LB9912	JOJCC0000415	\$(JOJCC0000415)	JOJCC0000415
PS9902	K1KB10A00131	\$(K1KB10A00131)	\$(K1KB10A00131)
R9942	330	\$	\$

Confidential
Unit 11

DMC-TZ20/ZS10
Top Operation
Schematic Diagram

S4.4. SD Card Schematic Diagram / S4.5. Gyro Schematic Diagram

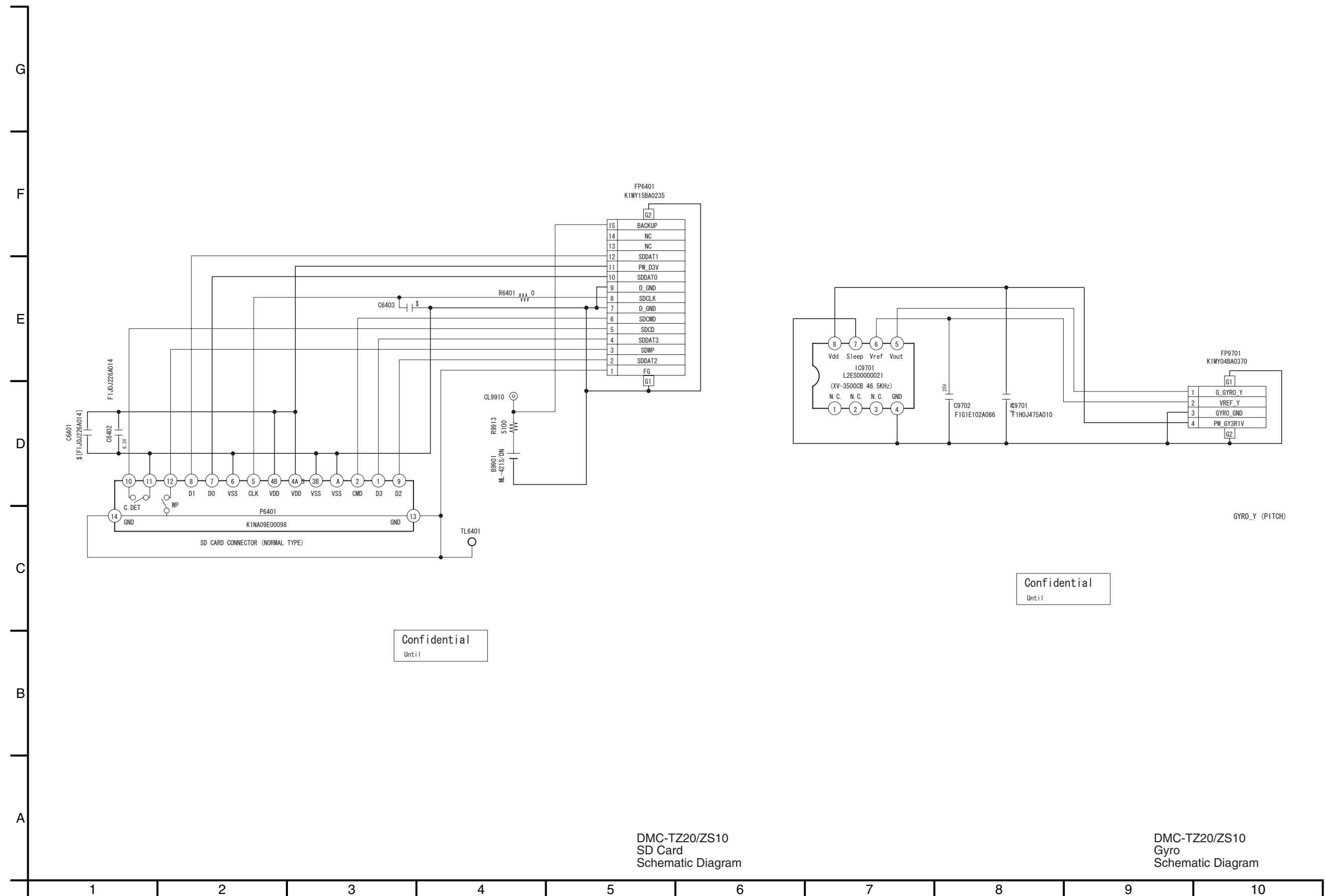

Confidential
Until

Confidential
Until

DMC-TZ20/ZS10
SD Card
Schematic Diagram

DMC-TZ20/ZS10
Gyro
Schematic Diagram

S4.6. Lens Flex Schematic Diagram

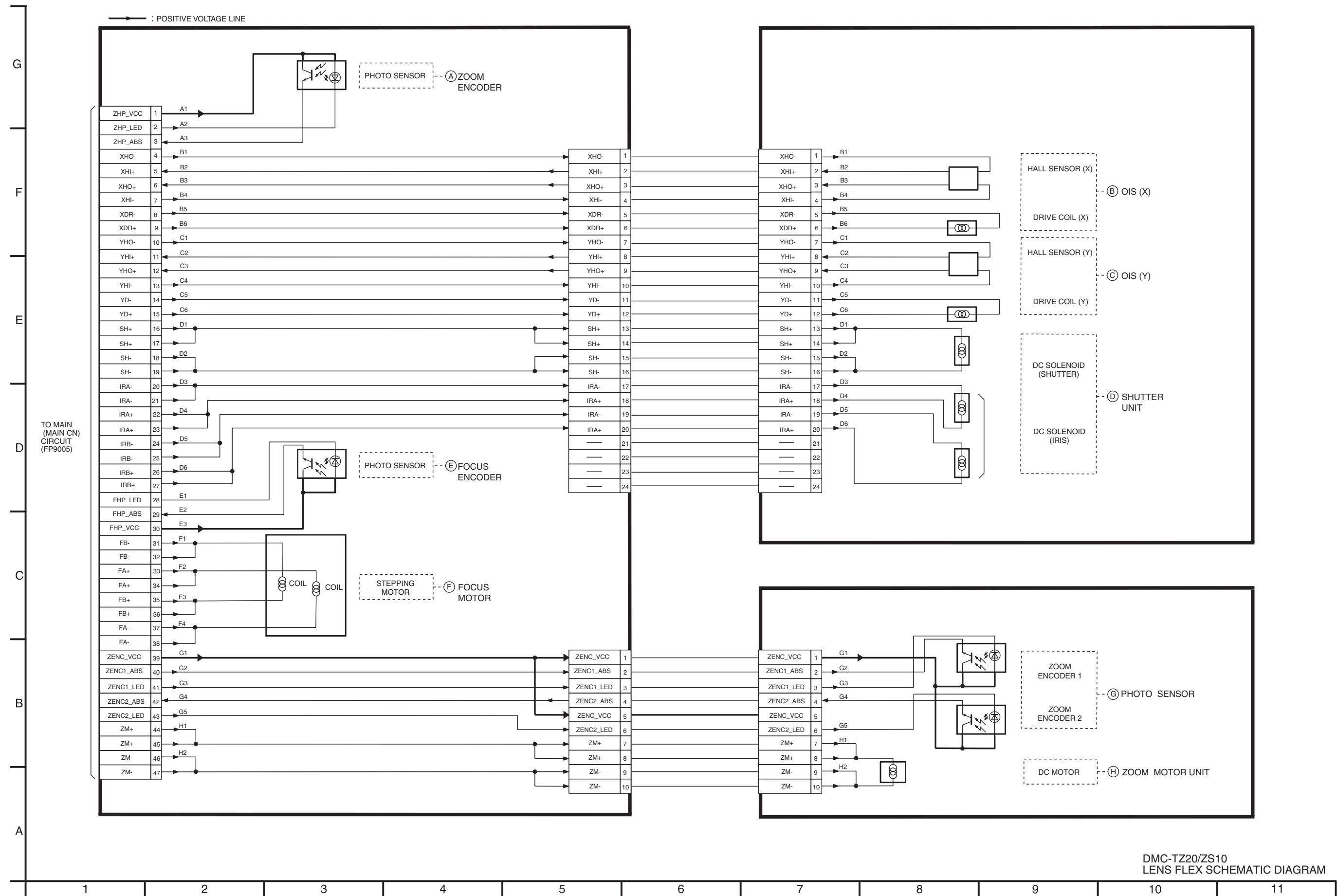

S5. Print Circuit Board

S5.1. Flash P.C.B.

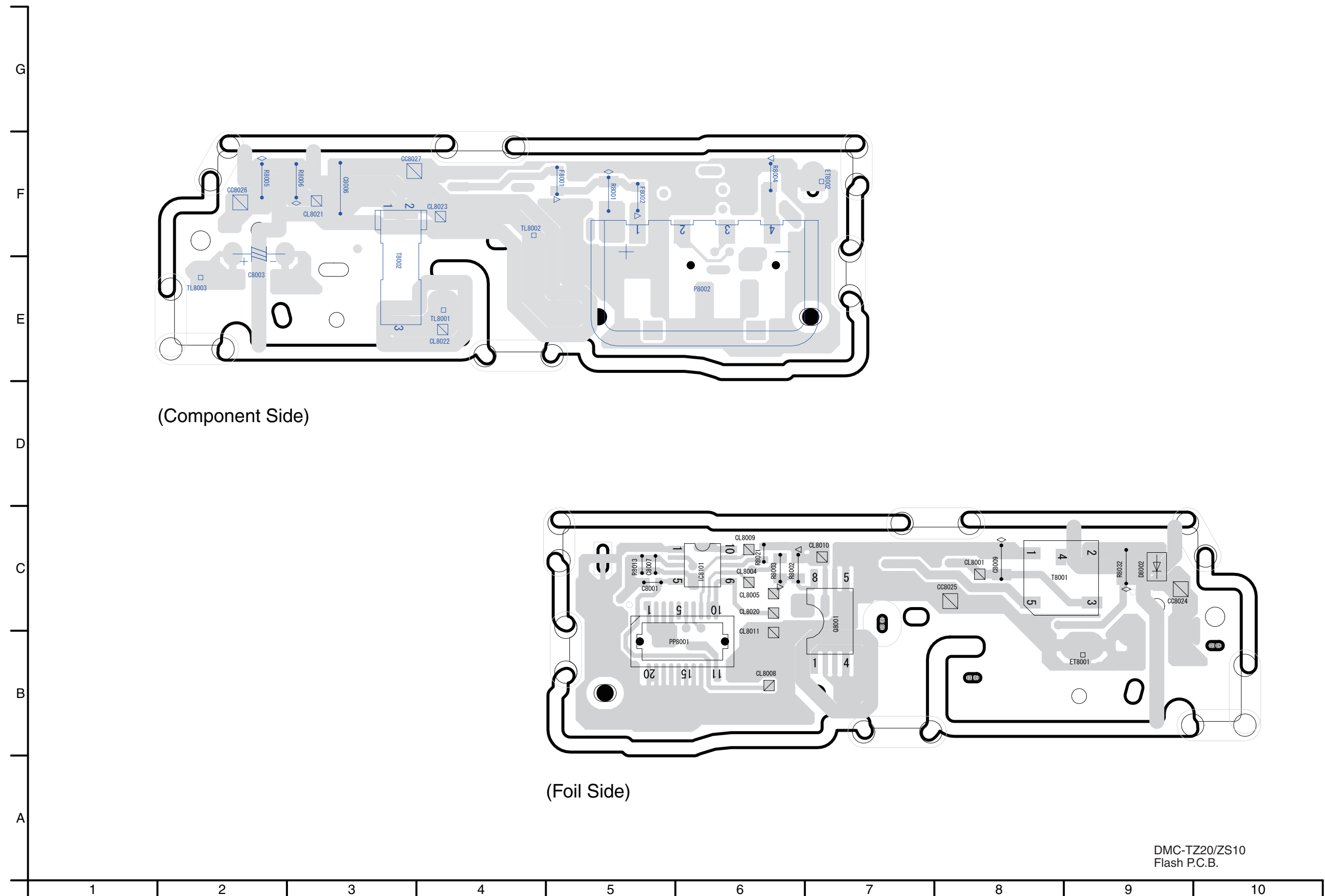

S5.2. Top Operation P.C.B.

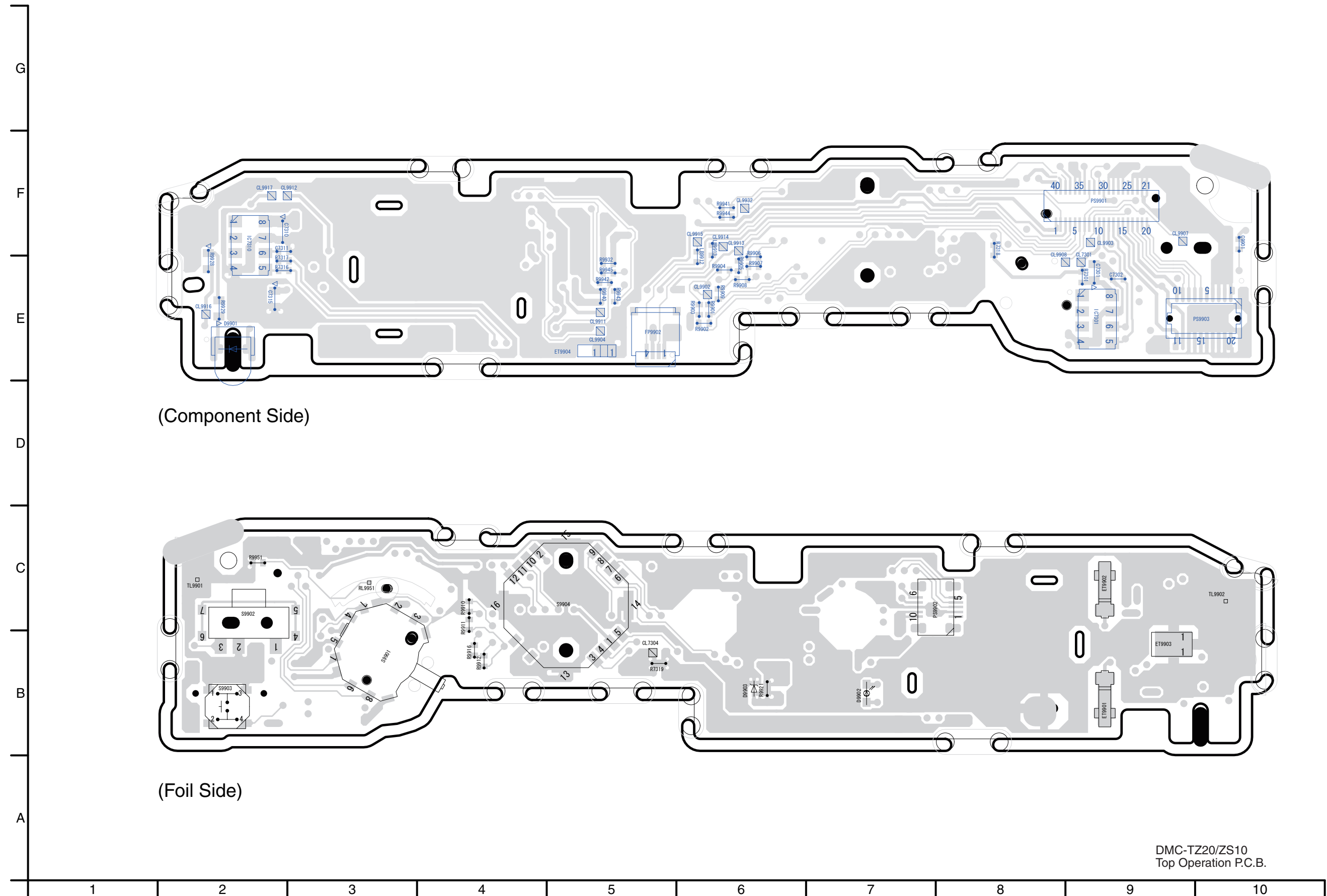

S5.3. SD P.C.B.

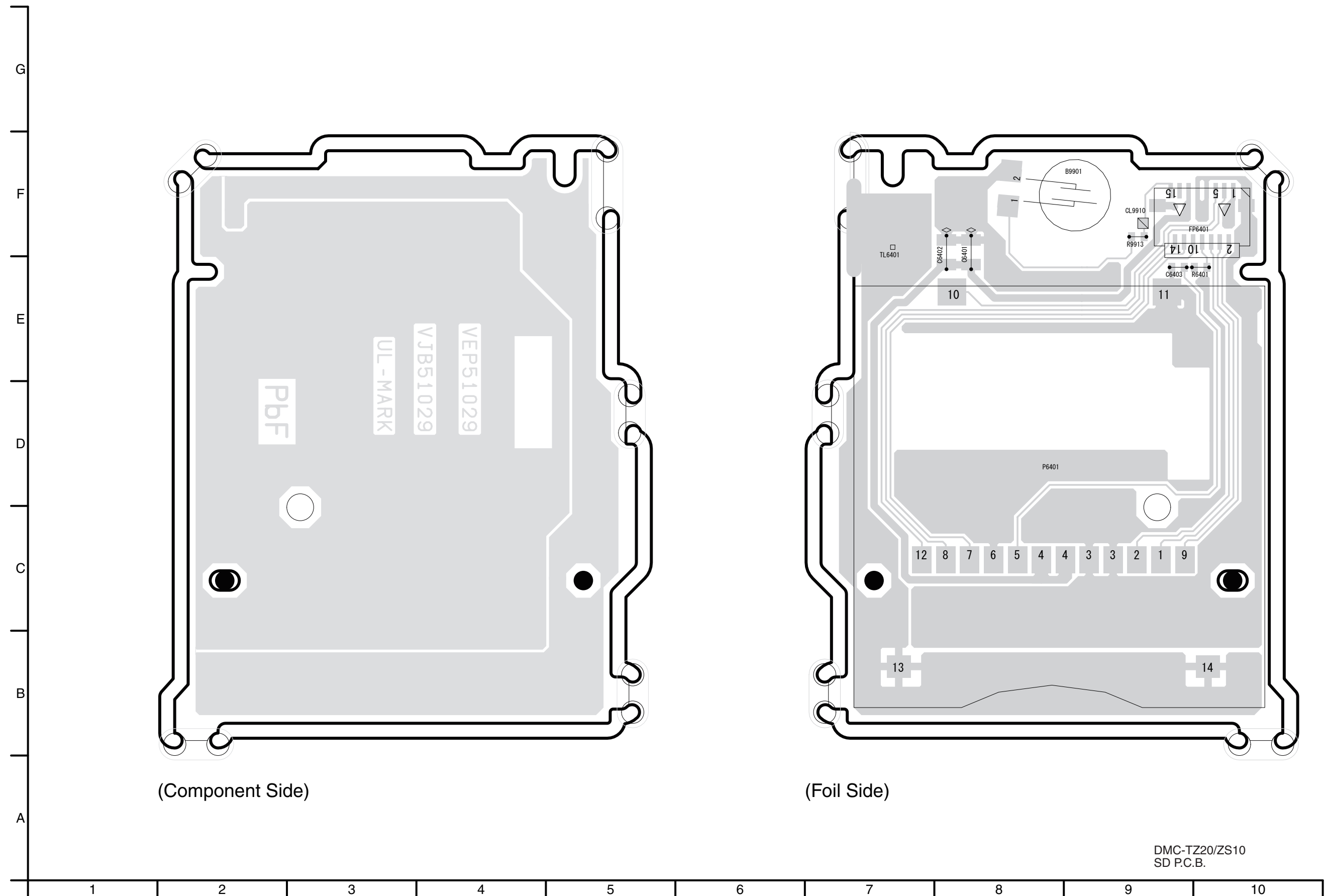

DMC-TZ20/ZS10
SD P.C.B.

S5.4. Gyro P.C.B.

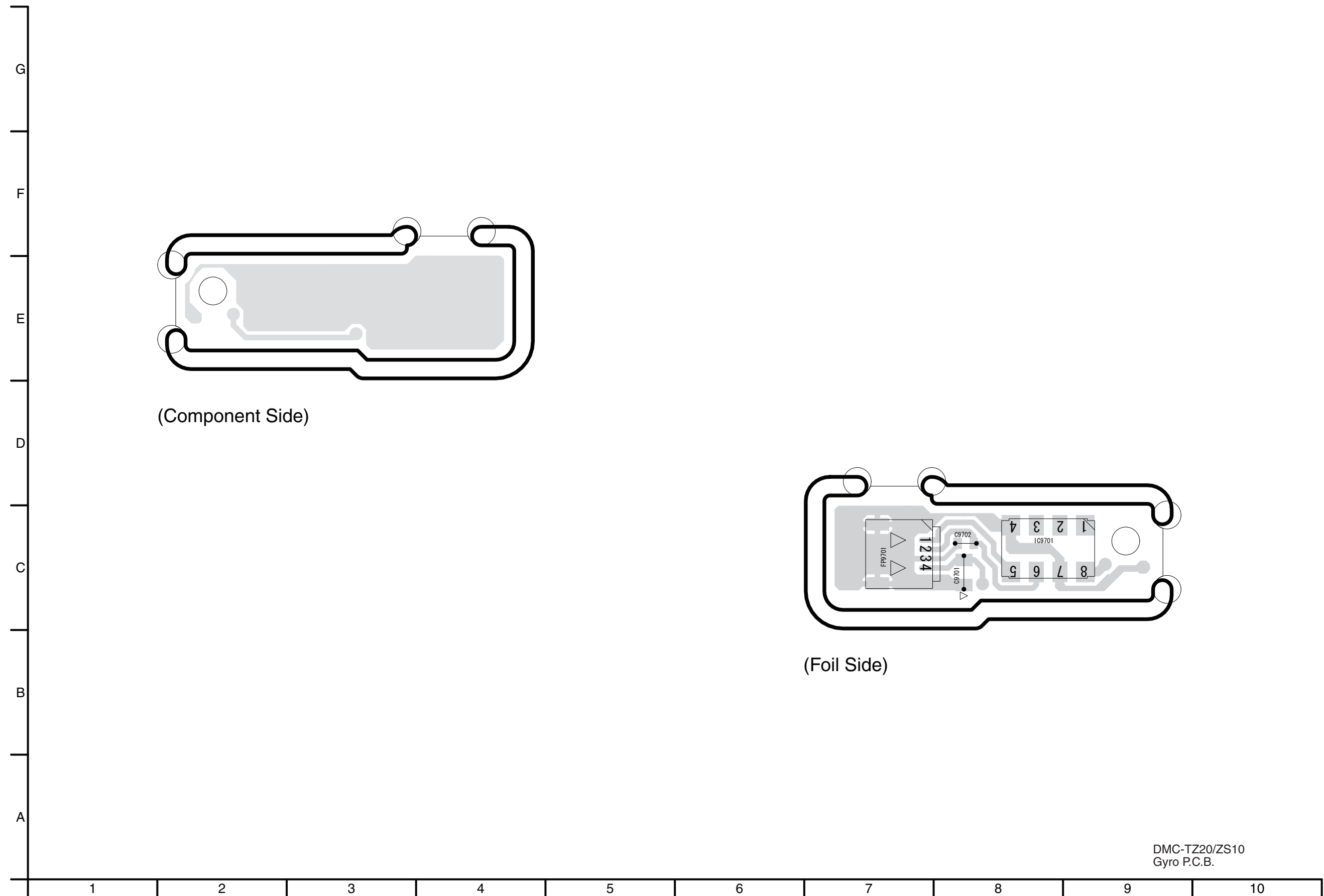

S5.5. Lens Flex P.C.B.

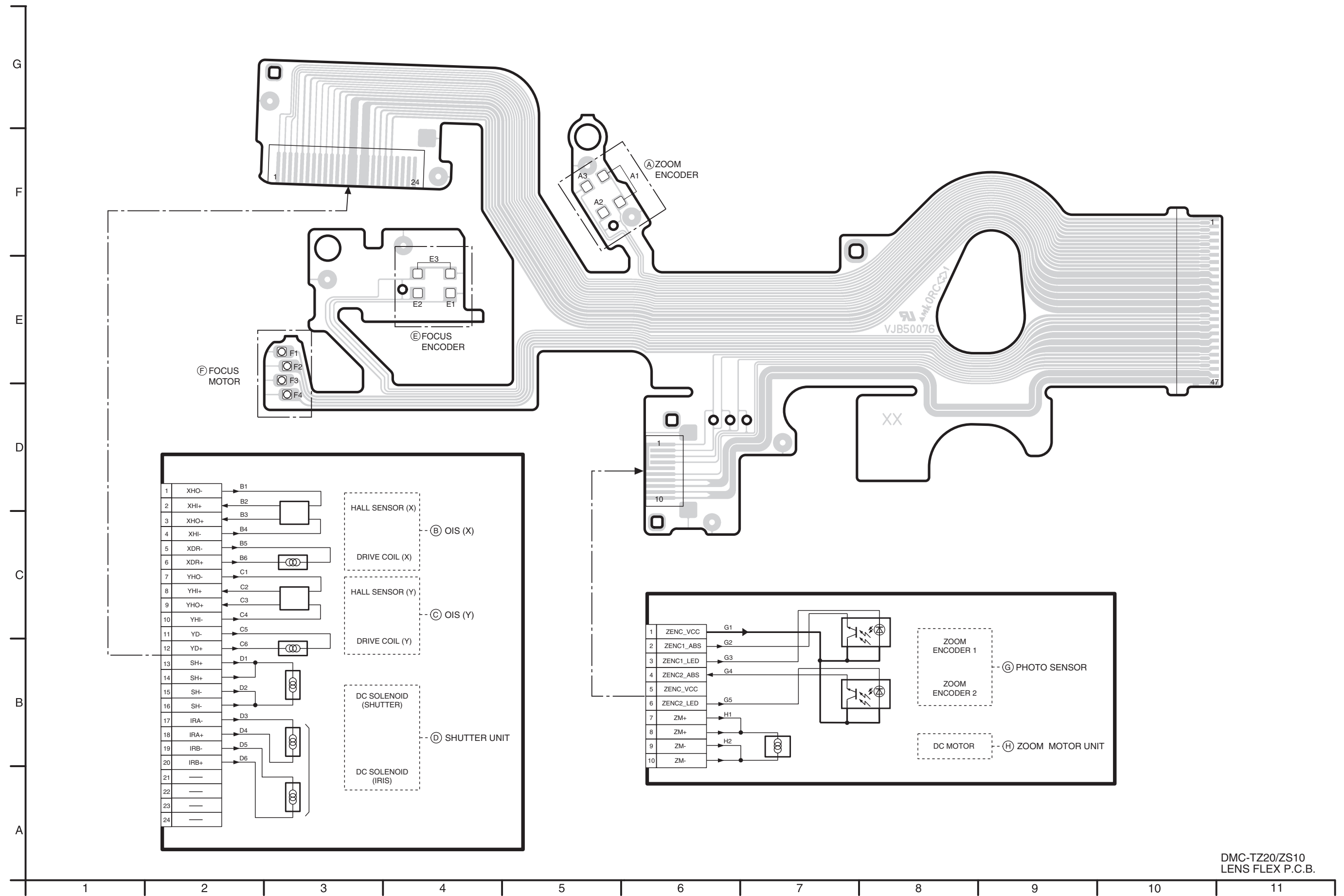

S6. Replacement Parts List

- Note:
1. * Be sure to make your orders of replacement parts according to this list.
 2. **IMPORTANT SAFETY NOTICE**
Components identified with the mark  have the special characteristics for safety.
When replacing any of these components, use only the same type.
 3. Unless otherwise specified,
All resistors are in OHMS, K=1,000 OHMS. All capacitors are in MICRO-FARADS (uf), P=uuF.
 4. The marking (RTL) indicates the retention time is limited for this item. After the discontinuation of this assembly in production, it will no longer be available.
 5. Supply of CD-ROM, in accordance with license protection, is allowable as replacement parts only for customers who accidentally damaged or lost their own.

E.S.D. standards for Electrostatically Sensitive Devices, refer to PREVENTION OF ELECTROSTATIC DISCHARGE (ESD) TO ELECTROSTATICALLY SENSITIVE (ES) DEVICES section.

Definition of Parts supplier:

1. Parts marked with [ENERGY] in the remarks column are supplied from Panasonic Corporation Energy Company.
2. Parts marked with [SPC] in the remarks column are supplied from AVC-CSC-SPC. Others are supplied from PAVCSG.

DMC-TZ20EB-S

Ref.No.	Part No.	Part Name & Description	Pcs	Remarks	Ref.No.	Part No.	Part Name & Description	Pcs	Remarks
1	VEP56124B	MAIN P.C.B.	1	(RTL) E.S.D. EB,EF,EG,EP	47	VGK3732	SIDE ORNAMENT R	1	
1	VEP56124A	MAIN P.C.B.	1	(RTL) E.S.D. EE,GC,GN,SG, GD,GH,GT,P,PC,PU	48	VYK4T70	REAR CASE UNIT	1	(-S) [PAVCSG]
1	VEP56124C	MAIN P.C.B.	1	(RTL) E.S.D. GK	48	VYK4T71	REAR CASE UNIT	1	(-K) [PAVCSG]
2	N5HZ2000089	GPS MODULE	1	EB,EE,EF,EG,EP,GC,GN,SG, GD,GH,GT,P,PC,PU	48	VYK4T75	REAR CASE UNIT	1	(-T) [PAVCSG]
3	VMP9905	MAIN HEAT RADI PLATE	1	[PAVCSG]	48	VYK4T74	REAR CASE UNIT	1	(-R) [PAVCSG]
4	L0AA01A00032	SPEAKER	1		48	VYK4T72	REAR CASE UNIT	1	(-A) [PAVCSG]
5	L0CBAA000015	MICROPHONE UNITS	1		48	VYK4T73	REAR CASE UNIT	1	(-N) [PAVCSG]
6	VGL1268	AF PANEL LIGHT	1		48-1	VGU0H72	CURSOR BUTTON	1	[PAVCSG]
7	VGQ0S26	FRASH SPACER	1		48-2	VGU0H73	MENU BUTTON	1	[PAVCSG]
8	VGQ0U66	TOP INSULATION TAPE	1		48-3	VGU0H74	SLIDE KNOB	1	[PAVCSG]
9	VEP50080A	TOP OPERATION P.C.B	1	(RTL) E.S.D. EB,EE,EF,EG, EP,GC,GN,SG,GD,GH,GT, P,PC,PU	48-4	VGQ0X09	PROTECTION SHEET	1	
9	VEP50080C	TOP OPERATION P.C.B	1	(RTL) E.S.D. GK	56	VGQ0S28	PCB SPACER	1	[PAVCSG]
10	VYK4L73	TOP CASE ASS'Y	1	EB,EE,EF,EG,EP,GC,GN,SG	57	VMP9904	FRONT HEAT RADI PLATE	1	[PAVCSG]
10	VYK4L74	TOP CASE ASS'Y	1	GD,GH,GT,P,PC,PU	60	VGQ0V68	GRAPHITE SHEET	1	[PAVCSG]
10	VYK4L75	TOP CASE ASS'Y	1	GK	61	VGQ0W96	CONNECTOR SHEET	1	
11	VMP9894	FRAME	1	[PAVCSG]	62	VGQ0X07	BL SHEET	1	
12	VKF4895	JACK DOOR	1	[PAVCSG]	63	VGQ0X10	ORNAMENT SHEET	1	
△ 13	ML-421S/DN	BUTTON BATTERY	1	(B9901) [ENERGY]	64	VGQ0X13	MIC FPC SHEET	1	
14	VMS8146	JACK DOOR SHAFT	1	[PAVCSG]	201	VEK0R67	CMOS UNIT	1	
15	VMS7863	BATTERY DOOR SHAFT	1	[PAVCSG]	202	VXP3523	1ST LENS FRAME UNIT	1	
16	VYK4T90	BATTERY DOOR ASS'Y	1	(-S) [PAVCSG]	203	VXP3525	1ST DIRECT FRAME	1	
16	VYK4T91	BATTERY DOOR ASS'Y	1	(-K) [PAVCSG]	204	VDW2175	TWO SIDE CAM FRAME	1	
16	VYK4T95	BATTERY DOOR ASS'Y	1	(-T) [PAVCSG]	205	VXP3526	2ND LENS FRAME UNIT	1	
16	VYK4T94	BATTERY DOOR ASS'Y	1	(-R) [PAVCSG]	206	VXP3527	3RD LENS FRAME UNIT	1	
16	VYK4T92	BATTERY DOOR ASS'Y	1	(-A) [PAVCSG]	207	VDW2179	2ND/3RD DIRECT FRAME	1	
16	VYK4T93	BATTERY DOOR ASS'Y	1	(-N) [PAVCSG]	210	VXQ1999	FIX CAM FRAME UNIT	1	
17	VEK0R27	FLASH U	1		211	VDW2183	ROTARY FRAME	1	
18	VEP58148A	FLASH P.C.B.	1	(RTL) E.S.D.	212	VXQ2081	MASTER FRANGE UNIT	1	[PAVCSG]
19	VMT2156	THERMAL TAPE	1	[PAVCSG]	212-1	VXP3530	4TH LENS FRAME UNIT	1	[PAVCSG]
21	VEP50079A	GYRO P.C.B.	1	(RTL) E.S.D.[PAVCSG]	212-2	VMB4251	FOCUS SPRING	1	[PAVCSG]
22	VYK4T40	FRONT CASE ASS'Y(1)	1	EB-S,EE-S,EG-S,EP-S,GC-S, GN-S,SG-S,GH-S,GK-S, GT-S,PU-S [PAVCSG]	212-3	VXP3531	5TH LENS FRAME UNIT	1	[PAVCSG]
22	VYK4T41	FRONT CASE ASS'Y(1)	1	EB-K,EE-K,EF-K,EG-K,EP-K, GC-K,GN-K,SG-K,GD-K, GH-K,GK-K,GT-K,PC-K,PU-K [PAVCSG]	212-4	L6HAYYYC0036	STEPPING MOTORS	1	[PAVCSG]
22	VYK4T45	FRONT CASE ASS'Y(1)	1	EE-T,EF-T,EG-T,EP-T,GC-T, GN-T,GK-T,GT-T [PAVCSG]	212-5	VMB4448	5TH SPRING	1	[PAVCSG]
22	VYK4T44	FRONT CASE ASS'Y(1)	1	EB-R,EE-R,EF-R,EG-R,EP-R, GC-R,GN-R,SG-R,GK-R, PC-R,PU-R [PAVCSG]	212-6	VDW2224	FOCUS COVER	1	[PAVCSG]
22	VYK4T42	FRONT CASE ASS'Y(1)	1	EB-A,EE-A,EG-A,EP-A,GN-A, PC-A [PAVCSG]	213	L6DAYYYC0002	ZOOM MOTOR UNIT	1	[PAVCSG]
22	VYK4T43	FRONT CASE ASS'Y(1)	1	SG-N,GK-N [PAVCSG]	214	VEK0R13	LENS FPC	1	[PAVCSG]
22	VYK4T46	FRONT CASE ASS'Y(1)	1	P-S [PAVCSG]	214-1	B3NBA0000018	PHOTO SENSOR	1	[PAVCSG]
22	VYK4T47	FRONT CASE ASS'Y(1)	1	P-K [PAVCSG]	214-2	B3NBA0000018	PHOTO SENSOR	1	[PAVCSG]
22	VYK4T51	FRONT CASE ASS'Y(1)	1	P-T [PAVCSG]	214-3	K1MY10BA0454	CONNECTOR(10P)	1	[PAVCSG]
22	VYK4T50	FRONT CASE ASS'Y(1)	1	P-R [PAVCSG]	214-4	K1MY24BA0454	CONNECTOR(24P)	1	[PAVCSG]
22	VYK4T48	FRONT CASE ASS'Y(1)	1	P-A [PAVCSG]	216	VXW1201	LENS UNIT (W/O CMOS)	1	
22	VYK4T49	FRONT CASE ASS'Y(1)	1	P-N [PAVCSG]	B1	VHD2071	SCREW	1	
22-1	VGQ0S21	LENS ORNAMENT	1	[PAVCSG]	B2	VHD2071	SCREW	1	
23	VEP51029A	SD CARD P.C.B.	1	(RTL) E.S.D.[PAVCSG]	B3	VHD2071	SCREW	1	
24	VYK4U14	LCD PANEL ASS'Y (1)	1		B4	VHD2081	SCREW	1	
24-1	VYK5C81	TOUCH PANEL U	1		B5	VHD2081	SCREW	1	
25	VMP9976	GPS EARTH PLATE	1	[PAVCSG]	B6	VHD1909	SCREW	1	
26	VWJ2240	SD MAIN JOINT FPC	1	[PAVCSG]	B7	VHD1909	SCREW	1	
27	VYK4U16	FRAME PLATE ASS'Y	1		B8	VHD1909	SCREW	1	
29	VMB4507	BATTERY LOCK SPRING	1	[PAVCSG]	B9	XQN14+BJ35FN	SCREW	1	
30	VGQ0L97	BATTERY LOCK KNOB	1	[PAVCSG]	B10	XQN14+BJ35FN	SCREW	1	
32	VMP9912	EARTH PLATE L	1		B13	VHD1924-A	SCREW	1	[PAVCSG]
33	VGQ0J81	TROPID	1	[PAVCSG]	B14	VHD1924-A	SCREW	1	[PAVCSG]
34	VMB4462	EARTH SPRING	1	(ET8001)	B15	VHD1924-A	SCREW	1	[PAVCSG]
35	VMB4143	BATTERY DOOR SPRING	1	[PAVCSG]	B16	VHD1924-A	SCREW	1	[PAVCSG]
36	VMB4305	BATTERY OUT SPRING	1	[PAVCSG]	B17	VHD2194	SCREW	1	
37	VMP9896	BATTERY CASE	1	[PAVCSG]	B18	VHD2194	SCREW	1	
38	VWJ2241	GYRO FPC	1	[PAVCSG]	B19	VHD2194	SCREW	1	
△ 39	F2A2F9500007	CAPACITOR	1	(C8003)	B20	VHD2194	SCREW	1	
41	VGQ0P04	FPC SHEET	1	[PAVCSG]	B21	VHD2207	SCREW	1	
42	VGQ0P04	FPC SHEET	1	[PAVCSG]	B26	VHD2207	SCREW	1	
45	VGQ0S27	CONDENSER SPACER	1		B27	VHD2207	SCREW	1	
46	VGK3731	SIDE ORNAMENT L	1		B28	VHD2081	SCREW	1	[PAVCSG]
					B201	VHD1871	SCREW	1	
					B202	VHD1871	SCREW	1	
					B203	VHD1871	SCREW	1	
					B204	VHD2296	SCREW	1	
					B205	VHD2296	SCREW	1	
					B206	VHD2296	SCREW	1	
					B207	VHD2109	SCREW	1	[PAVCSG]
					B208	VHD2296	SCREW	1	[PAVCSG]
					B209	VHD2296	SCREW	1	[PAVCSG]
					B210	VHD2296	SCREW	1	[PAVCSG]
					B211	VHD2296	SCREW	1	
					B212	VHD2296	SCREW	1	[PAVCSG]

DMC-TZ20EB-S

Ref.No.	Part No.	Part Name & Description	Pcs	Remarks
301	VPF1137	CAMERA BAG	1	EB,EE,EF,EG,EP,GC,GN,SG, GD,GH,GT,PU
302	VPK4924	PACKING CASE	1	EB-S,EE-S,EG-S,EP-S,GC-S, GN-S,SG-S
302	VPK4929	PACKING CASE	1	EB-K,EE-K,EF-K,EG-K,EP-K, GC-K,GN-K,SG-K
302	VPK4939	PACKING CASE	1	EB-R,EE-R,EF-R,EG-R,EP-R, GC-R,GN-R,SG-R
302	VPK4943	PACKING CASE	1	EB-A,EE-A,EG-A,EP-A,GN-A
302	VPK4933	PACKING CASE	1	EE-T,EF-T,EG-T,EP-T, GC-T,GN-T
302	VPK4947	PACKING CASE	1	SG-N
302	VPK4930	PACKING CASE	1	GD-K,GH-K,GT-K,PU-K
302	VPK4925	PACKING CASE	1	GH-S,GT-S,PU-S
302	VPK4926	PACKING CASE	1	GK-S
302	VPK4931	PACKING CASE	1	GK-K
302	VPK4936	PACKING CASE	1	GK-T
302	VPK4941	PACKING CASE	1	GK-R
302	VPK4949	PACKING CASE	1	GK-N
302	VPK4935	PACKING CASE	1	GT-T
302	VPK4940	PACKING CASE	1	PU-R
△ 303	K2CT39A00002	AC CORD	1	EB,GC,GH
△ 303	K2CQ29A00002	AC CORD	1	EE,EF,EG,EP,GC
△ 303	K2CJ29A00002	AC CORD	1	GN
△ 303	K2CA29A00023	AC CORD	1	SG
△ 303	K2CR29A00001	AC CORD	1	GD
△ 303	K2CA29Y00070	AC CORD	1	GK
△ 303	K2CA29A00021	AC CORD	1	GT
△ 304	-----	BATTERY	1	(NOT SUPPLIED)
305	VFF0766-S	CD-ROM	1	EG
		(SOFT/INSTRUCTION BOOK)		See "Notes"
305	VFF0767-S	CD-ROM	1	EE,SG
		(SOFT/INSTRUCTION BOOK)		See "Notes"
305	VFF0768-S	CD-ROM	1	GC,GN,GH,SG
		(SOFT/INSTRUCTION BOOK)		See "Notes"
305	VFF0769-S	CD-ROM	1	GD,GT
		(SOFT/INSTRUCTION BOOK)		See "Notes"
305	VFF0770-S	CD-ROM	1	GK
		(SOFT/INSTRUCTION BOOK)		See "Notes"
305	VFF0765-S	CD-ROM	1	PU
		(SOFT/INSTRUCTION BOOK)		See "Notes"
305	VFF0803-S	CD-ROM	1	EB,EF,EP
		(SOFT/INSTRUCTION BOOK)		See "Notes"
△ 306	DE-A66AA	BATTERY CHARGER	1	EB,EF,EG,EP,GN
△ 306	DE-A66BB	BATTERY CHARGER	1	EE,GC,GD,GH,GK
△ 306	DE-A66EA	BATTERY CHARGER	1	SG
△ 306	DE-A66CA	BATTERY CHARGER	1	GT
△ 306	DE-A65BA	BATTERY CHARGER	1	PU
△ 307	VQT3G81	BASIC O/I	1	EB (ENGLISH)
△ 307	VQT3G82	BASIC O/I	1	EE (RUSSIAN/UKRAINIAN)
△ 307	VQT3G80	BASIC O/I	1	EF (FRENCH)
△ 307	VQT3G73	BASIC O/I	1	EG (GERMAN/FRENCH)
△ 307	VQT3G74	BASIC O/I	1	EG (ITALIAN/DUTCH)
△ 307	VQT3G75	BASIC O/I	1	EG (SPANISH/PORTUGUESE)
△ 307	VQT3G76	BASIC O/I	1	EG (TURKISH)
△ 307	VQT3G77	BASIC O/I	1	EP (SWEDISH/DANISH)
△ 307	VQT3G78	BASIC O/I	1	EP (POLISH/CZECH)
△ 307	VQT3G79	BASIC O/I	1	EP (HUNGARIAN/FINNISH)
△ 307	VQT3G83	BASIC O/I	1	GC,SG,GH (ENGLISH/ CHINESE(TRADITIONAL))
△ 307	VQT3G84	BASIC O/I	1	GC (ARABIC/PERSIAN)
△ 307	VQT3M15	BASIC O/I	1	GC (VIETNAMESE)

Ref.No.	Part No.	Part Name & Description	Pcs	Remarks
△ 307	VQT3G87	BASIC O/I	1	GN (ENGLISH)
△ 307	VQT3G88	BASIC O/I	1	GD (KOREAN)
△ 307	VQT3G86	BASIC O/I	1	GK (CHINESE(SIMPLIFIED))
△ 307	VQT3G85	BASIC O/I	1	GT (CHINESE(TRADITIONAL))
△ 307	VQT3G72	BASIC O/I	1	PU (SPANISH/PORTUGUESE)
308	K1HY08YY0017	USB CABLE	1	EB,EE,EF,EG,EP,GC,GN,SG, GD,GH,GT,PU
309	K1HY08YY0018	AV CABLE	1	EB,EE,EF,EG,EP,GC,GN,SG, GD,GH,GT,PU
310	VFC4297	HAND STRAP	1	EB,EE,EF,EG,EP,GC,GN,SG, GD,GH,GT,PU
311	VGQ0C14	STYLUS PEN	1	EB,EE,EF,EG,EP,GC,GN,SG, GD,GH,GT,PU
312	VPN7189	CUSHION	1	EB,EE,EF,EG,EP,GC,GN,SG, GD,GH,GT,PU
313	VPF1230	POLYETHYLENE COVER	1	EB,EE,EF,EG,EP,GC,GN,SG, GD,GH,GT,PU
314	VQL2C68-1	OPERATING LABEL	1	GT
315	VQC8094	O/I SOFTWARE	1	EB,GN (ENGLISH)
315	VQC8095	O/I SOFTWARE	1	EE (RUSSIAN/UKRAINIAN)
315	VQC8093	O/I SOFTWARE	1	EF (FRENCH)
315	VQC8091	O/I SOFTWARE	1	EG (GERMAN/ITALIAN/FRENCH/ DUTCH/SPANISH/ PORTUGUESE/TURKISH)
315	VQC8092	O/I SOFTWARE	1	EP (FINNISH/SWEDISH/DANISH/ POLISH/CZECH/HUNGARIAN)
315	VQC8096	O/I SOFTWARE	1	GC,SG,GH (ENGLISH/ CHINESE(TRADITIONAL)/ ARABIC/PERSIAN)
315	VQC8099	O/I SOFTWARE	1	GD (KOREAN)
315	VQC8098	O/I SOFTWARE	1	GK (CHINESE(SIMPLIFIED))
315	VQC8097	O/I SOFTWARE	1	GT (CHINESE(TRADITIONAL))
315	VQC8090	O/I SOFTWARE	1	PU (SPANISH/PORTUGUESE)

S7. Exploded View

S7.1. Frame and Casing Section

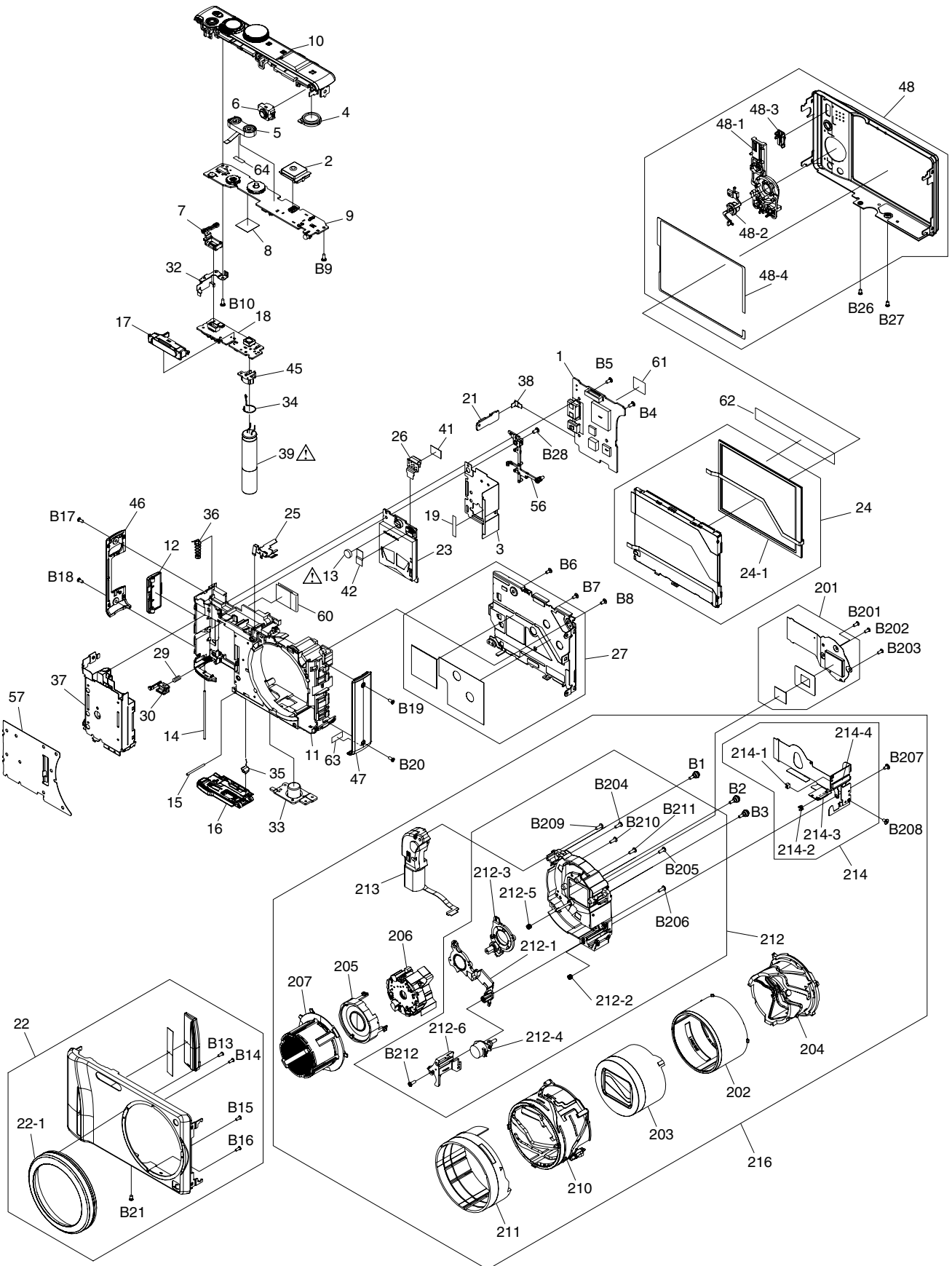

S7.2. Packing Parts and Accessories Section (1)

(except for P/PC)

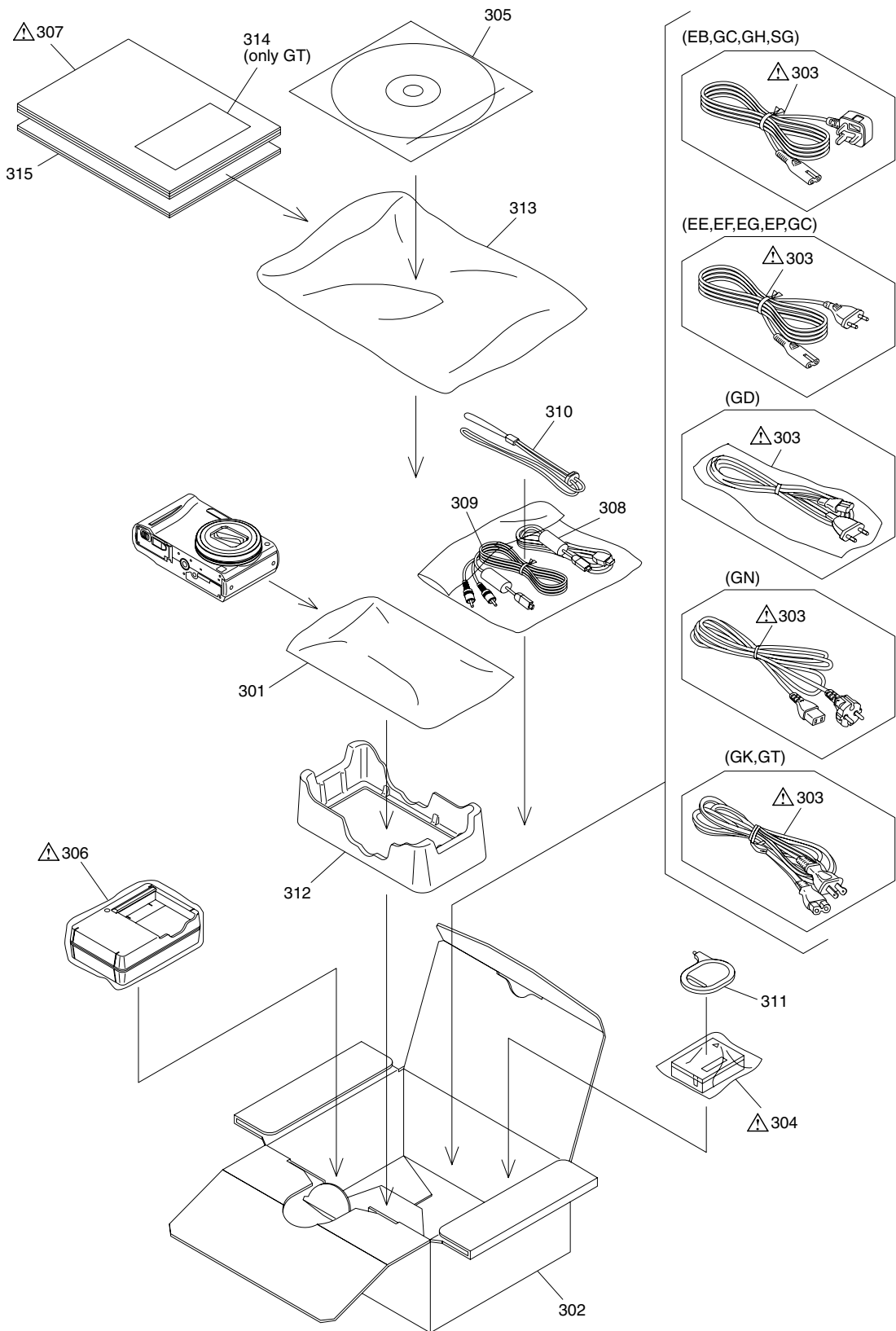

S7.3. Packing Parts and Accessories Section (2)

(Only P,PC)

