

4.5 SWITCHING REGULATOR AND REGULATOR SCHEMATIC DIAGRAMS

COMPARISON CHART OF MODELS & MARKS(#)

REF. NO.	MODELS	
	HR-J415E	HR-J415EG
C1	OPEN	USED
C2	0.068/250	0.033/250
C3	USED	OPEN
C6	USED	OPEN
C8	USED	OPEN

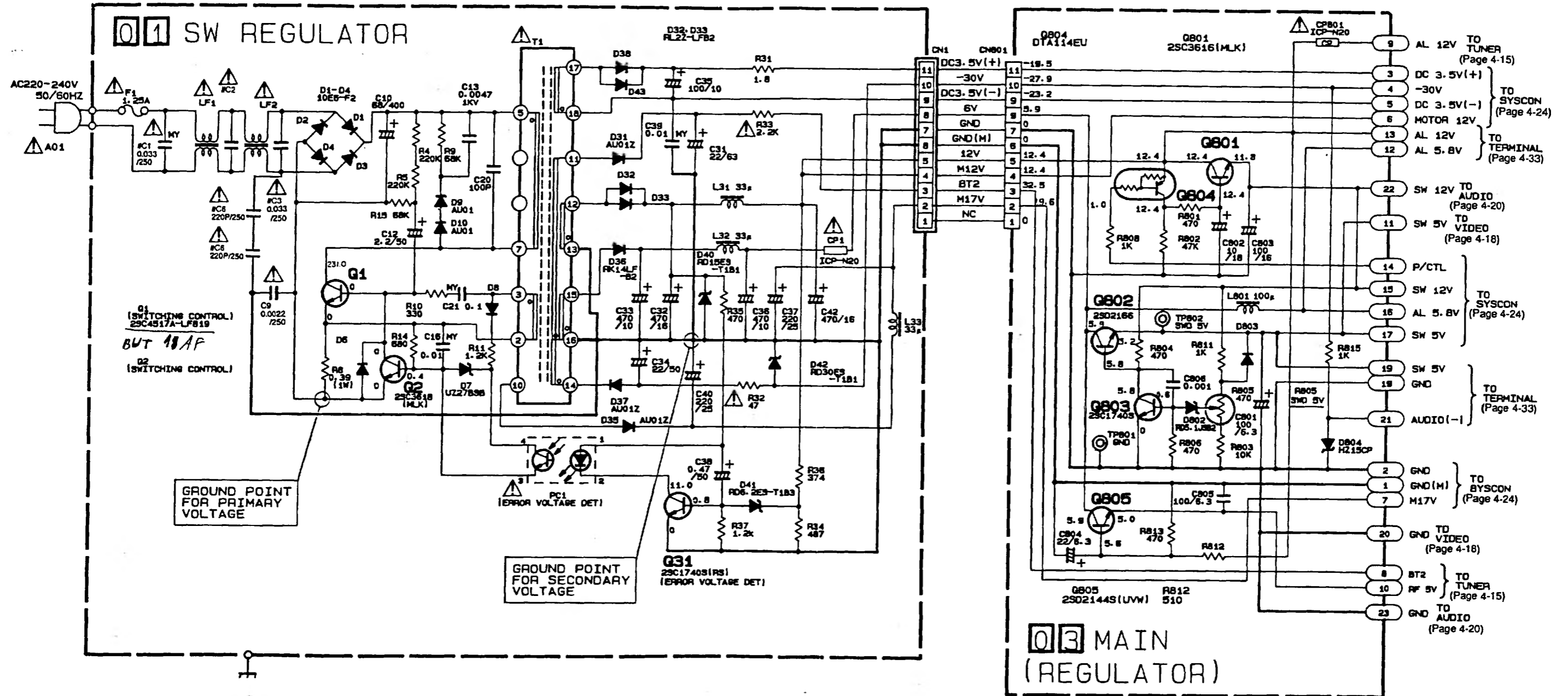

4.24 RF CONVERTER SCHEMATIC DIAGRAM

NOTE:

1. All parts shown in this schematic are critical for safety
2. This schematic is only for reference.
Avoid replacing individual parts.
Replace the entire unit only.

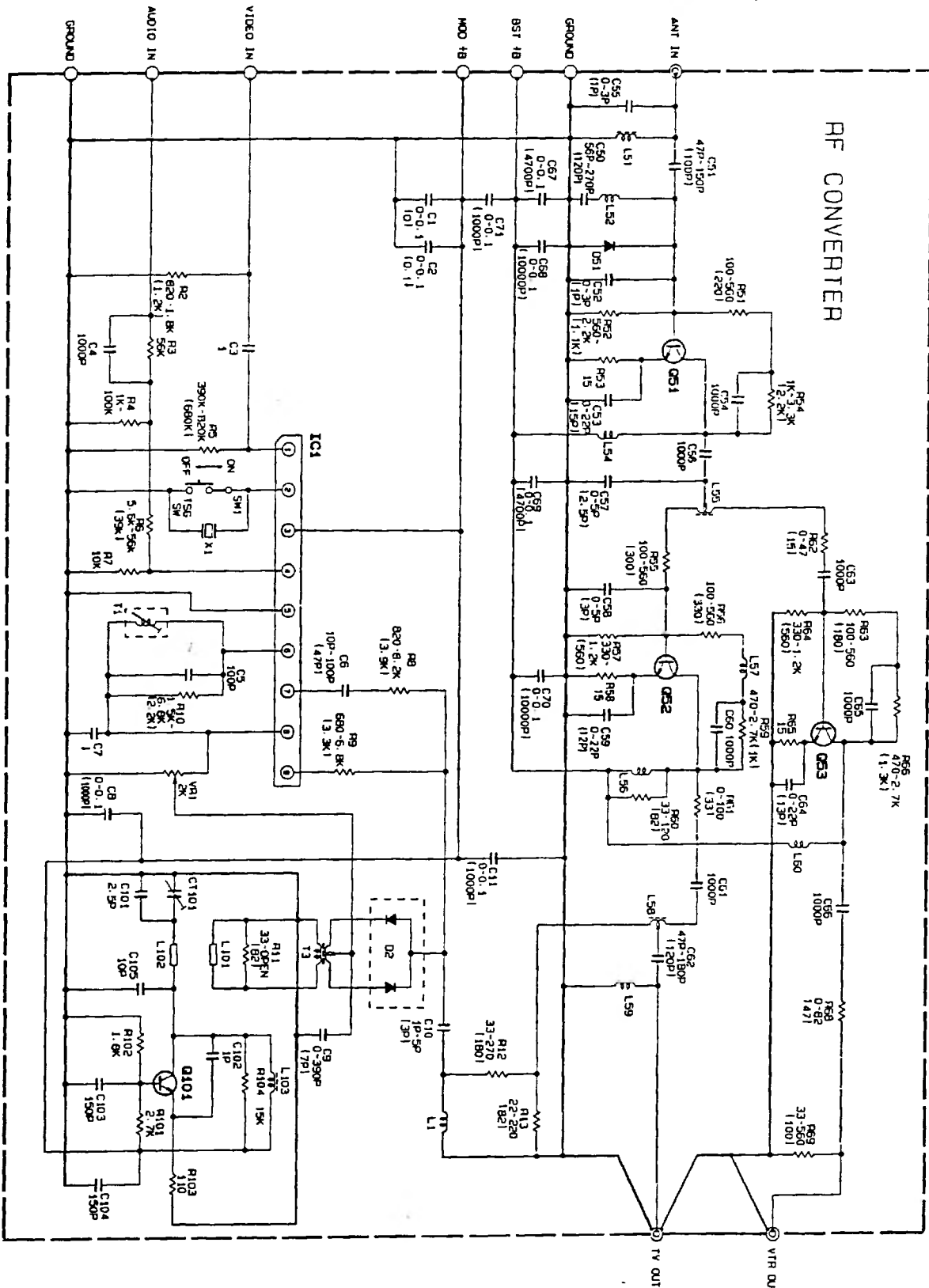

4.8 VIDEO SCHEMATIC DIAGRAM

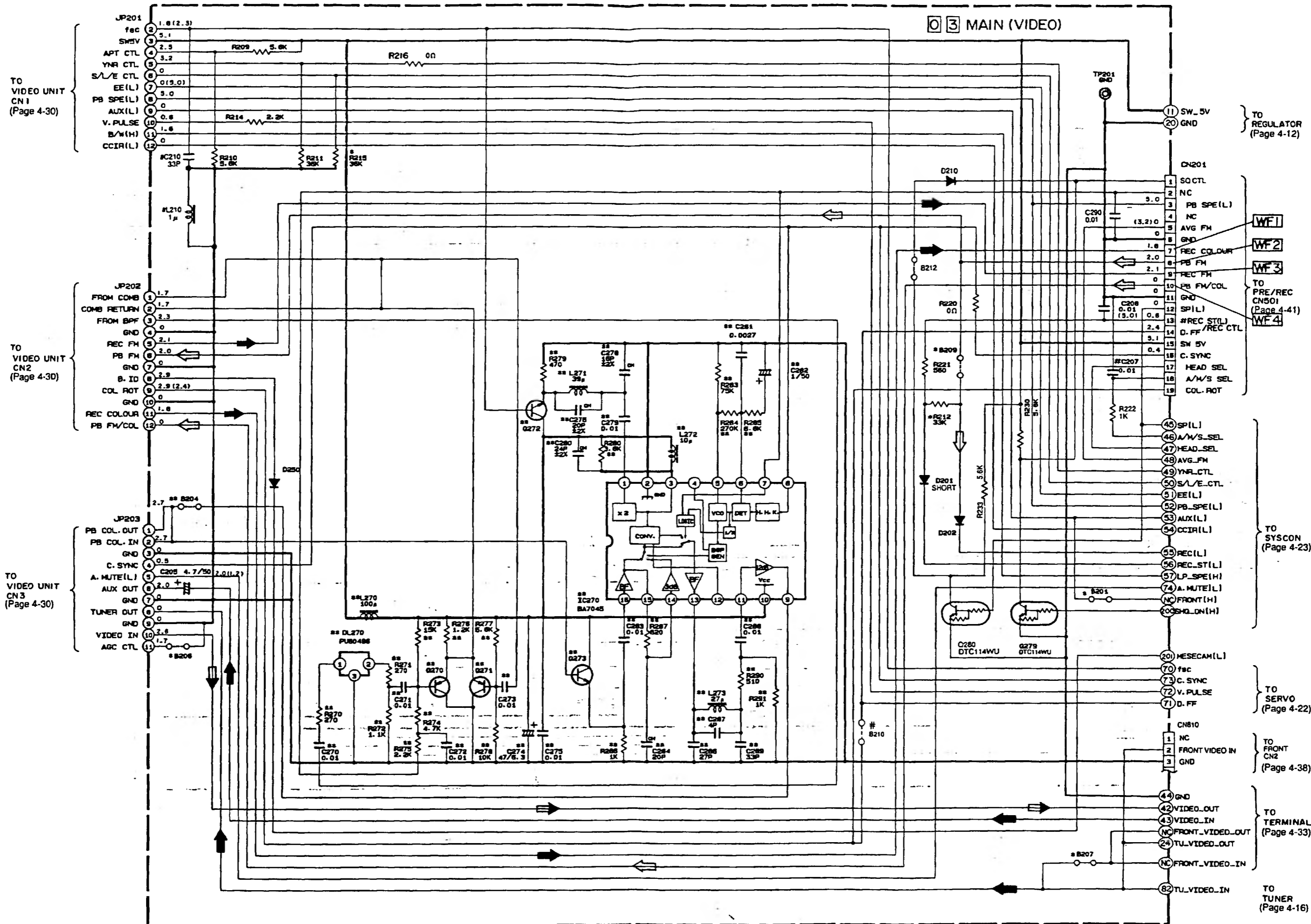

4.9 AUDIO SCHEMATIC DIAGRAM

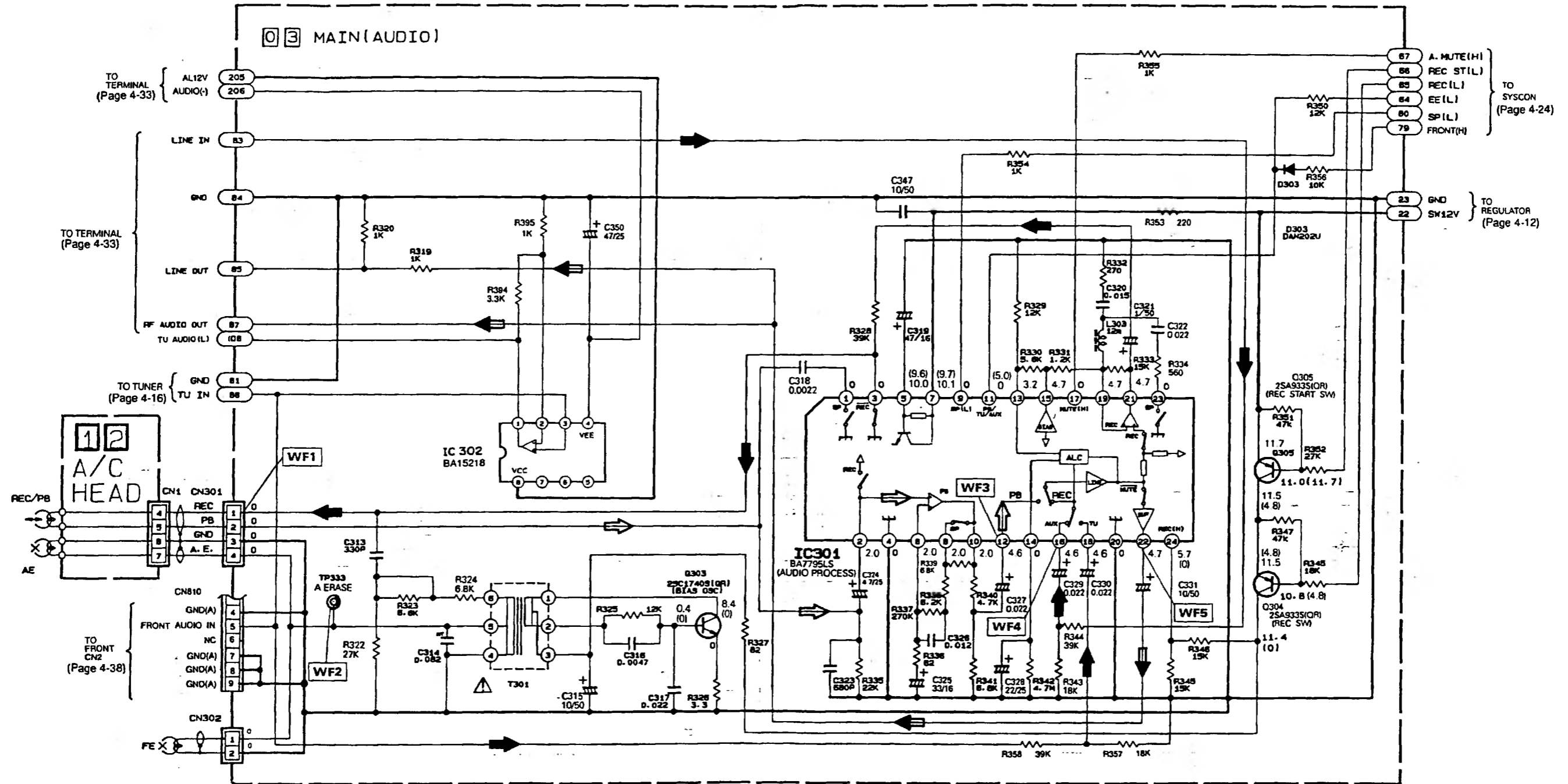

4.10 SERVO SCHEMATIC DIAGRAM

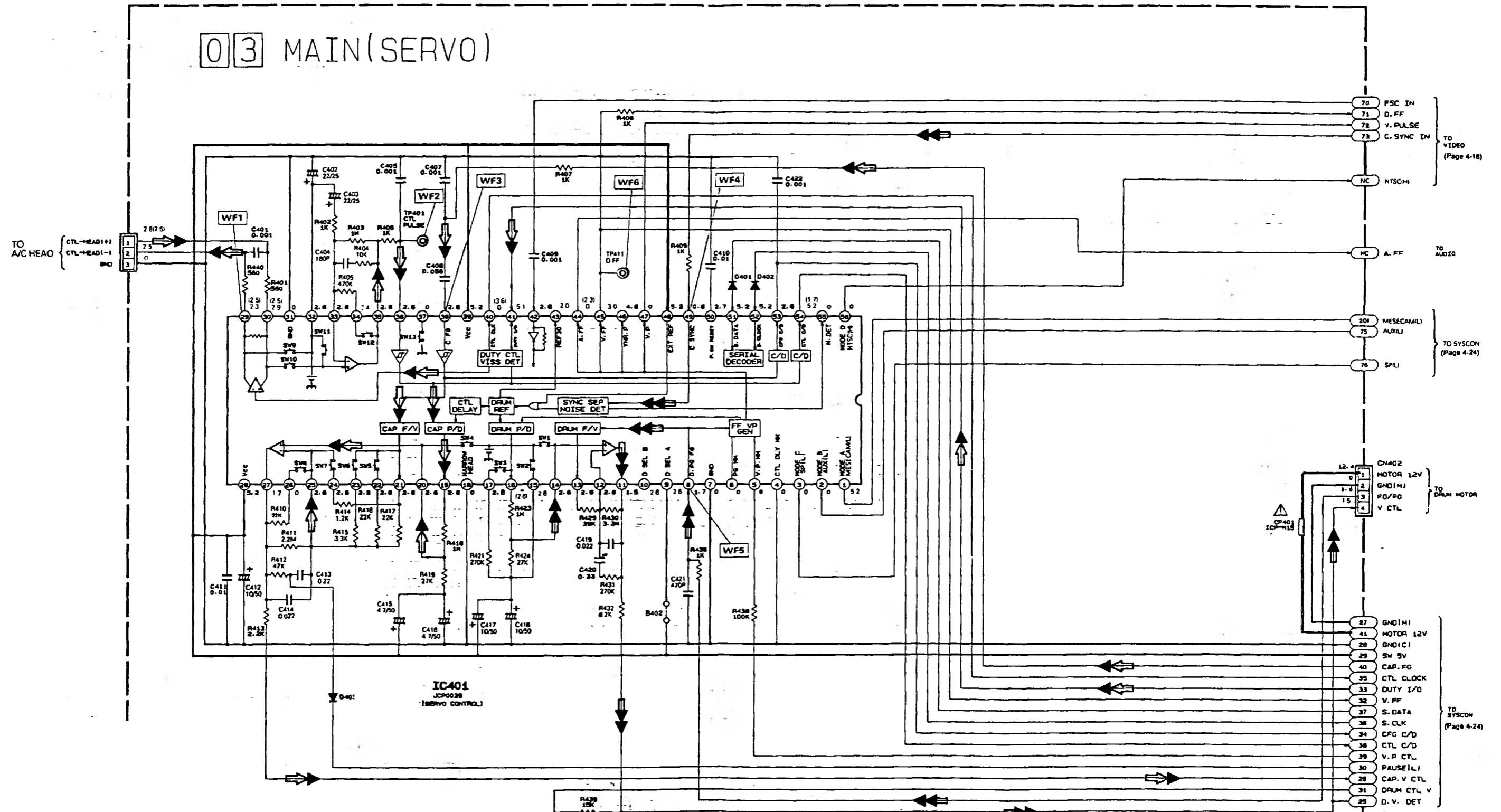

4.11 SYSCON SCHEMATIC DIAGRAM

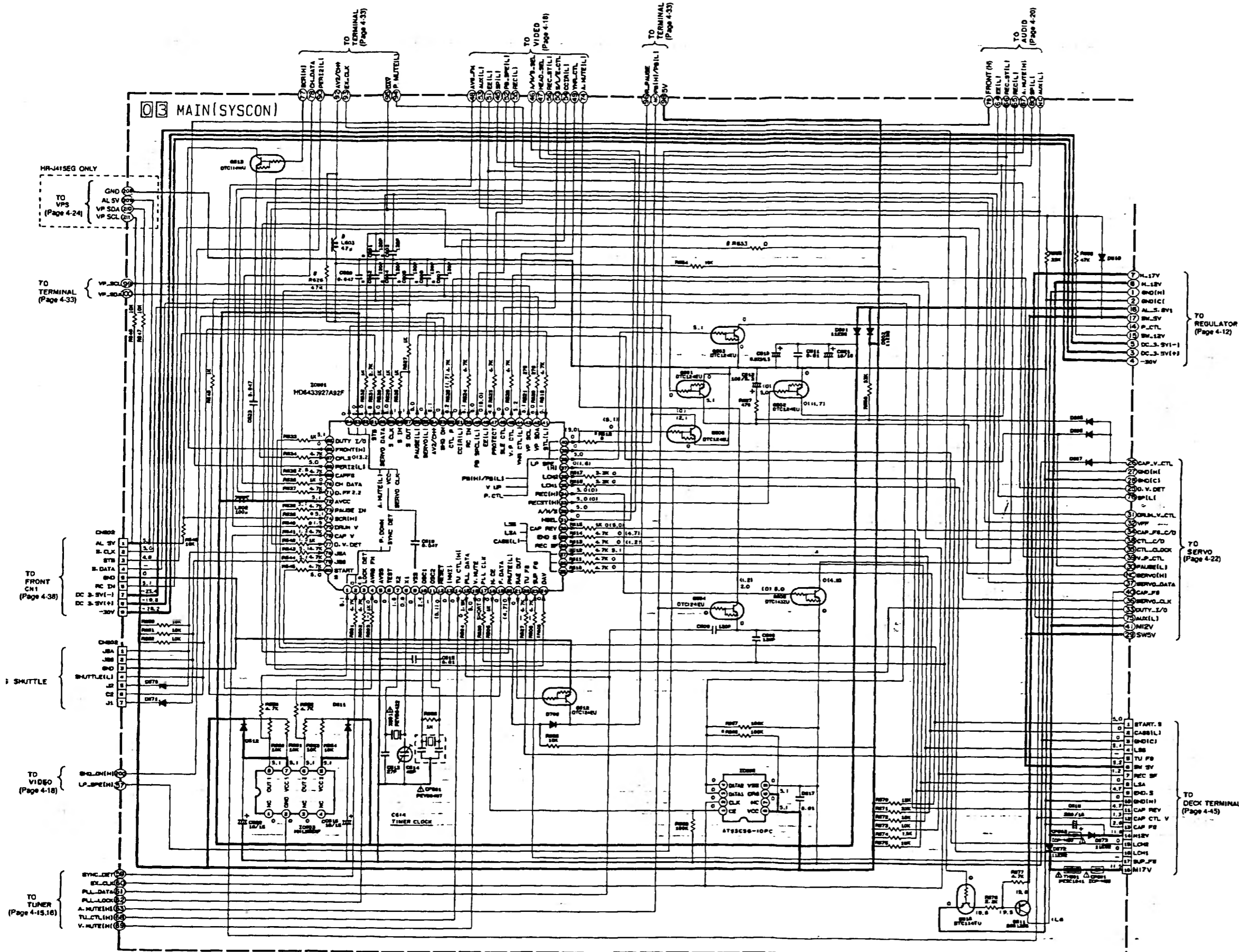

NOTE: "*" MARK ELEMENTS ARE NOT MOUNTED.

4.13 VIDEO UNIT SCHEMATIC DIAGRAM

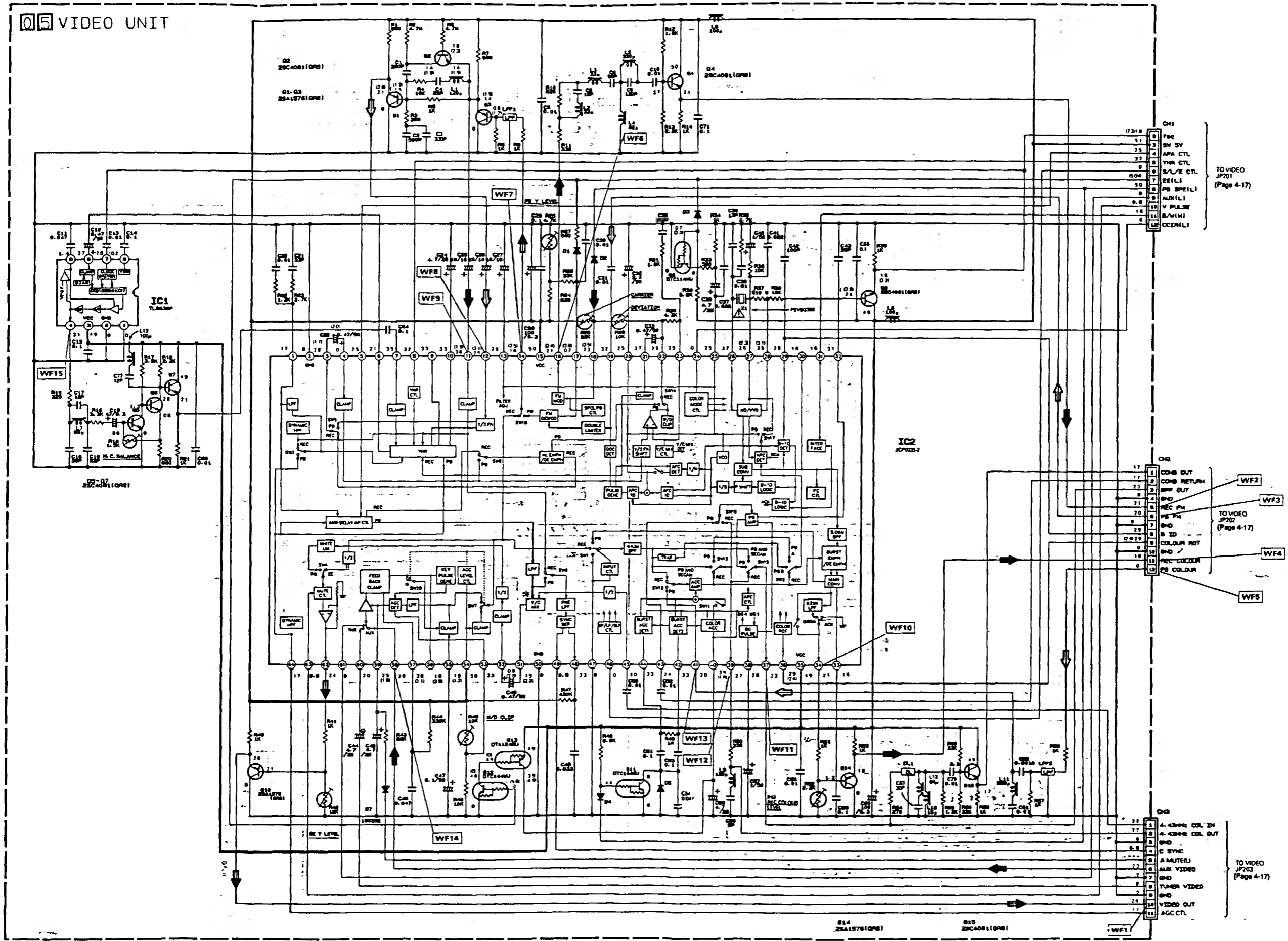

4.15 TERMINAL & MAIN (TERMINAL) SCHEMATIC DIAGRAMS

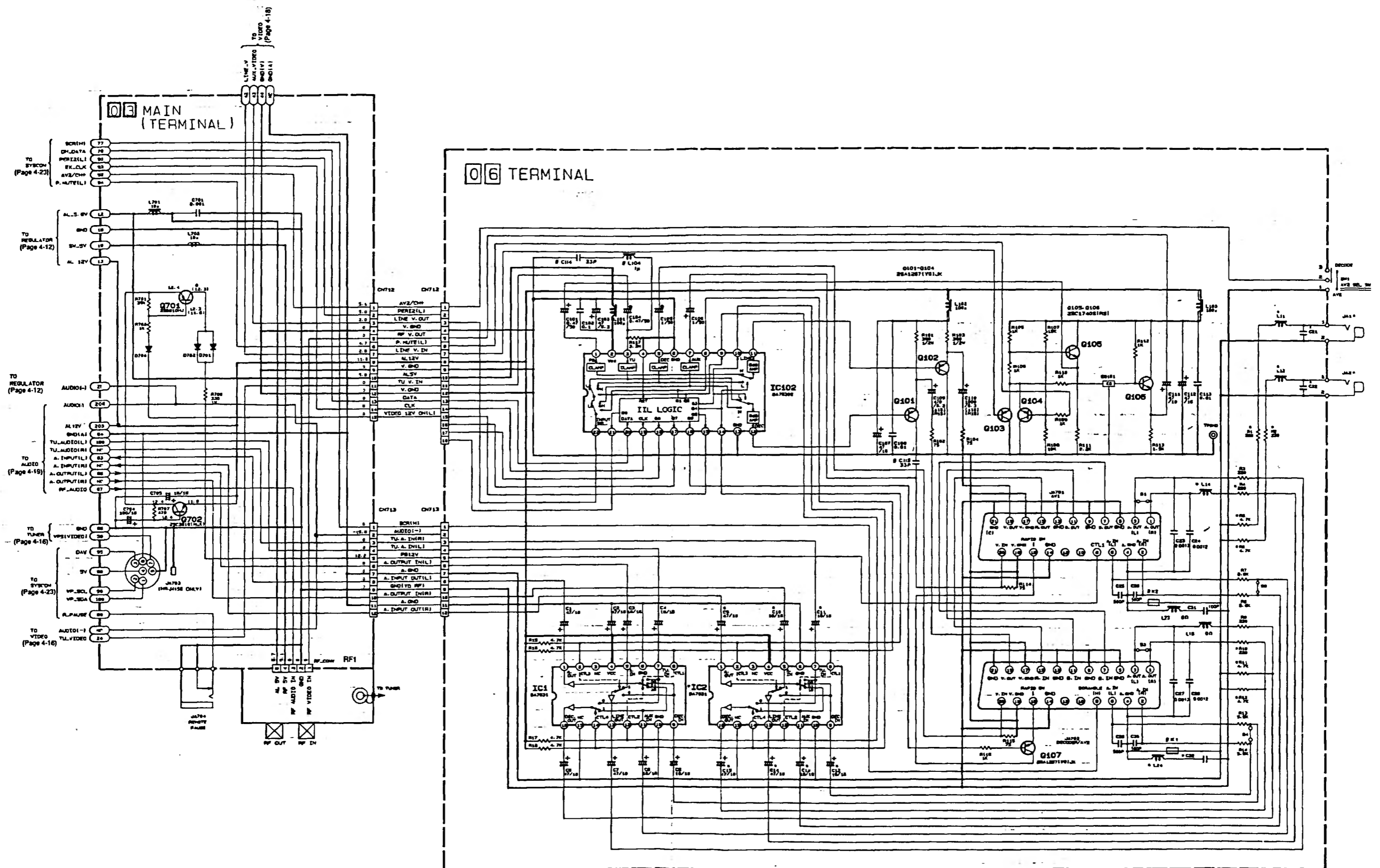

4.17 FRONT SCHEMATIC DIAGRAM

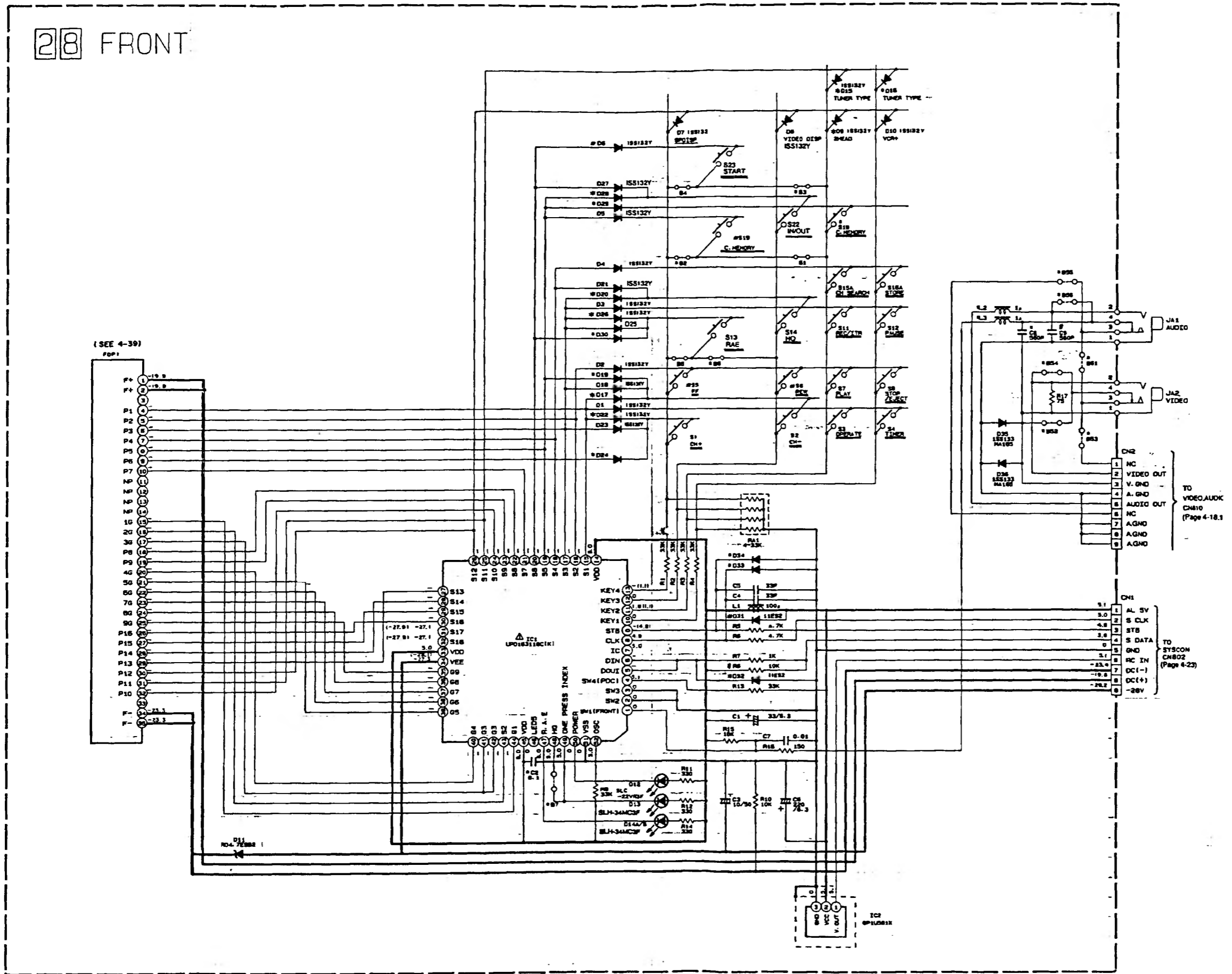

4.19 PRE/REC SCHEMATIC DIAGRAM

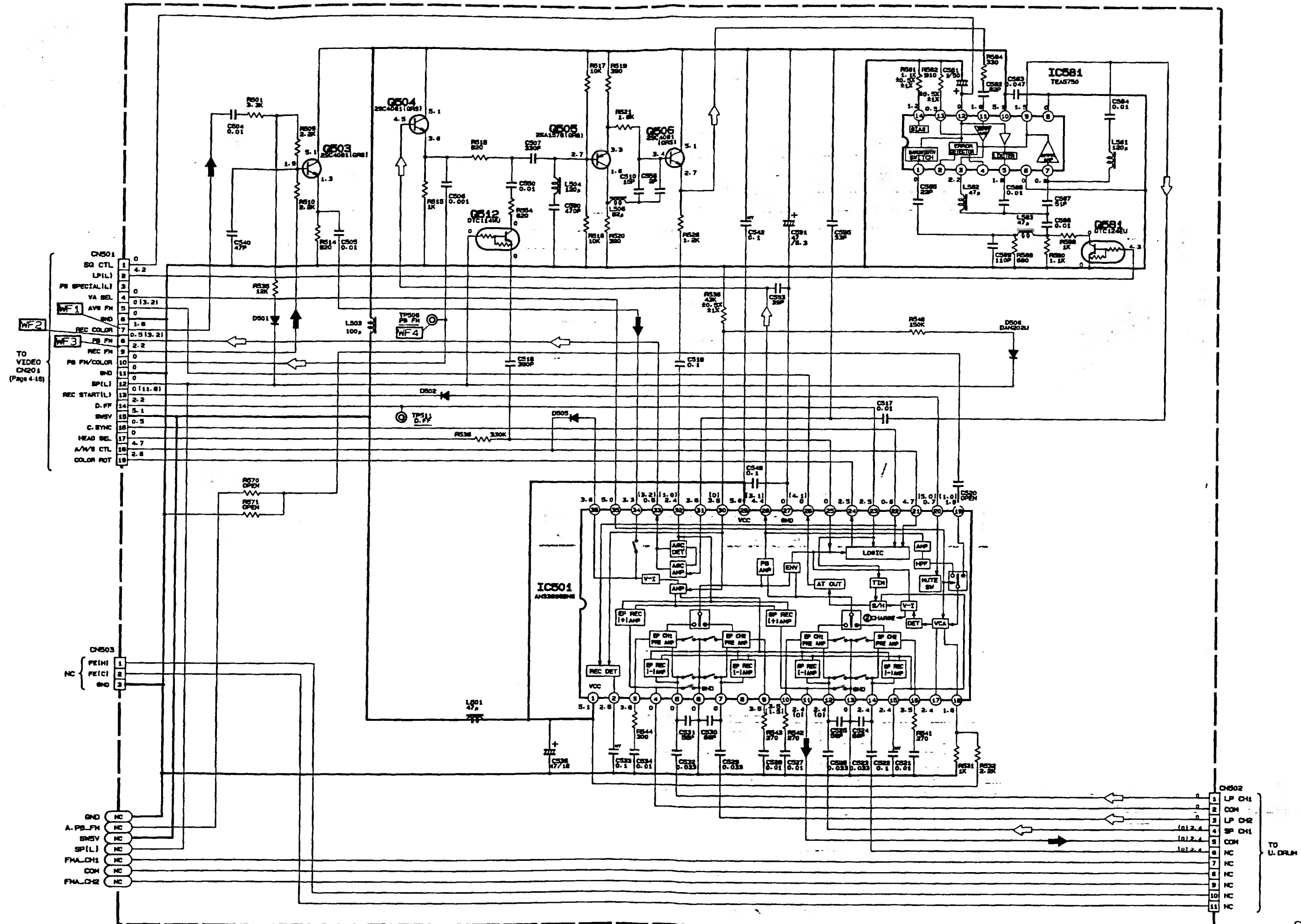

4.21 DECK TERMINAL, CASSETTE HOUSING AND CAPSTAN MDA SCHEMATIC DIAGRAMS

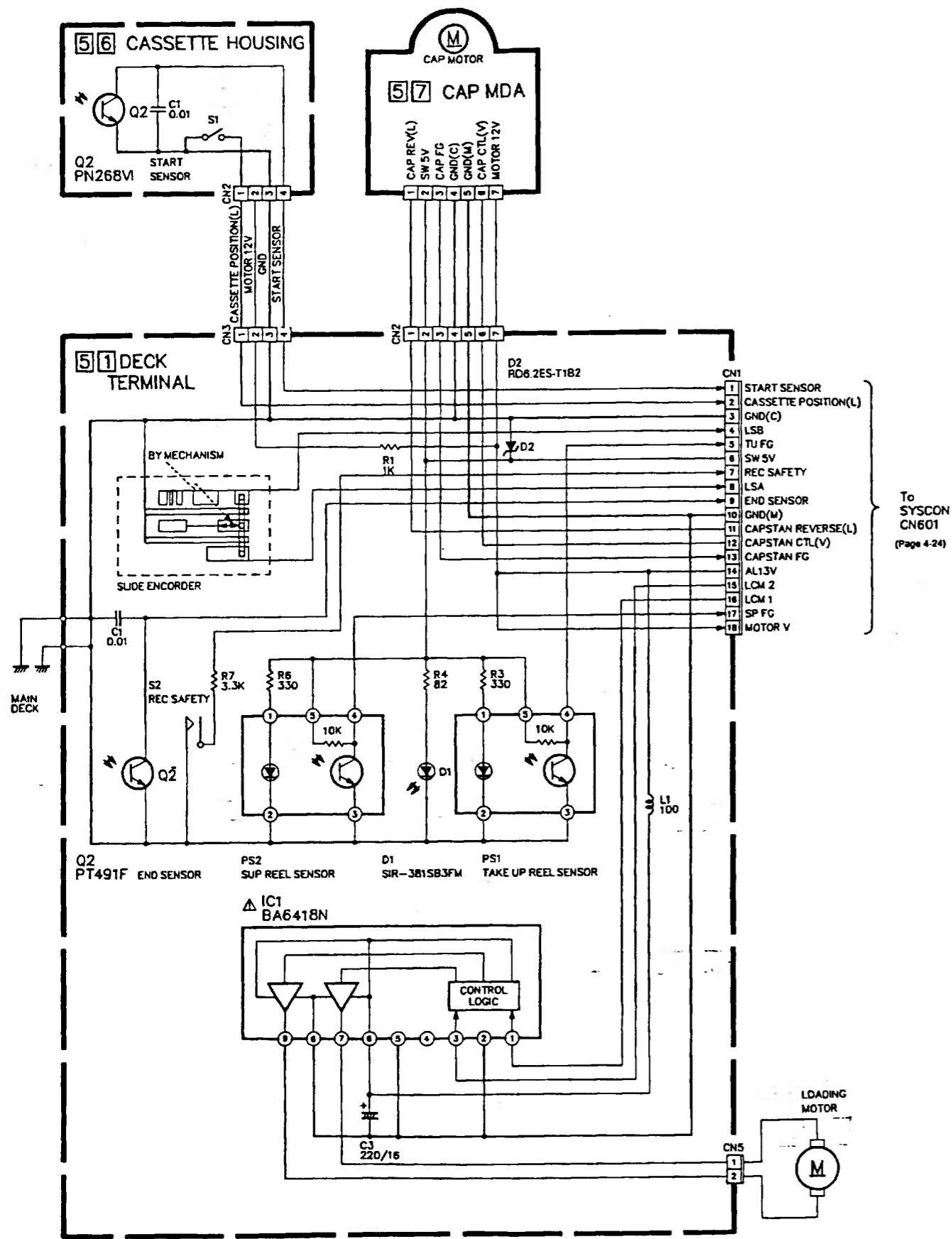

4.23 REMOTE CONTROL SCHEMATIC DIAGRAM

NOTE:

1. All parts shown in this schematic are critical for safety.
2. This schematic is only for reference.
Avoid replacing individual parts.
Replace the entire unit only.

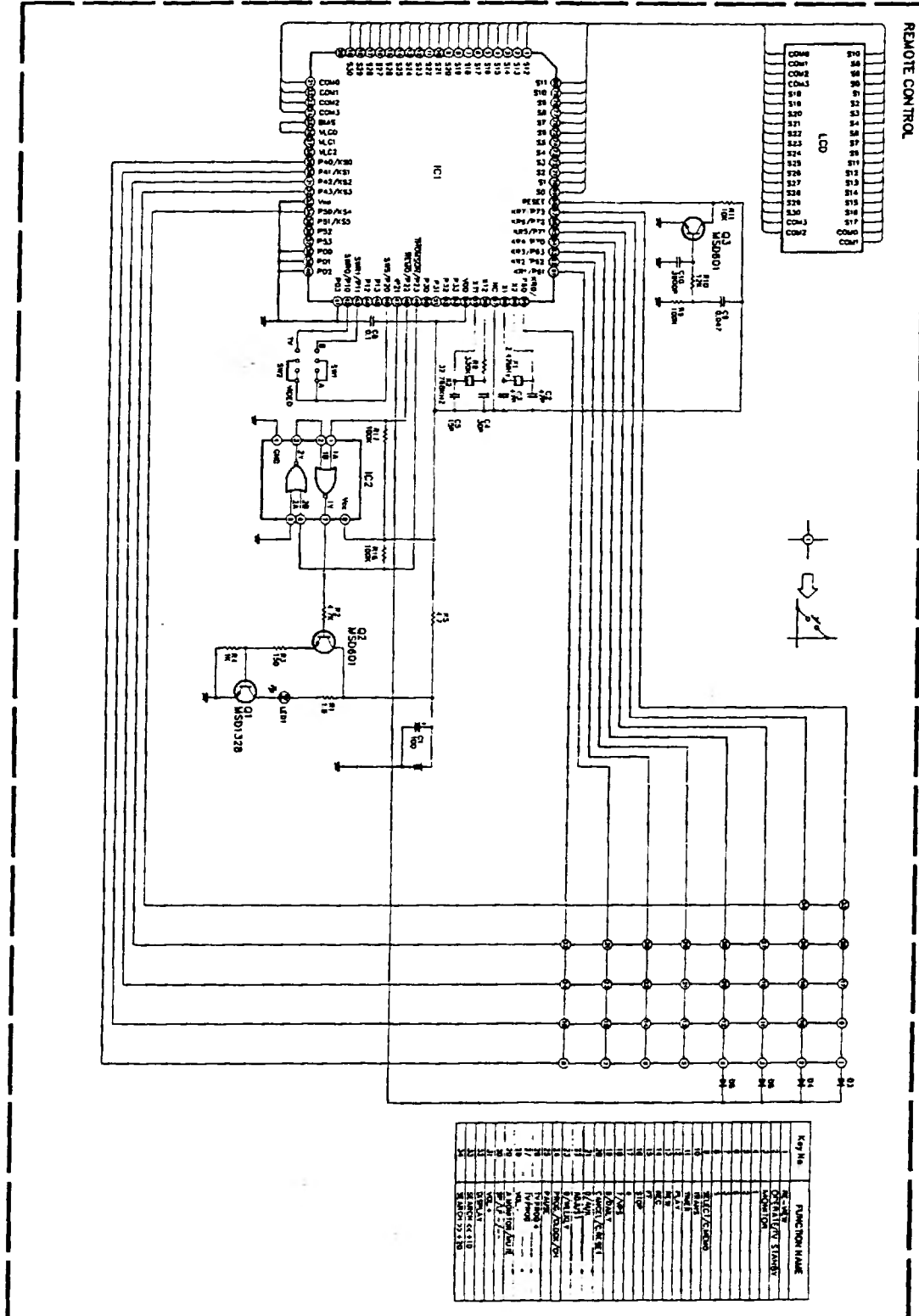

4.7 TUNER SCHEMATIC DIAGRAM

