

RDR-HXD790/HXD795/HXD890/HXD895/ HXD990/HXD995/HXD1090/HXD1095 RMT-D2510/D251P

SERVICE MANUAL

Self Diagnosis
Supported model

Ver. 1.& 20%\$. \$1



Photo: RDR-HXD1095
RMT-D251P

AEP Model
UK Model

RDR-HXD790/HXD795/
HXD890/HXD895/
HXD990/HXD995/
HXD1090/HXD1095

Australian Model
RDR-HXD890/HXD990



SPECIFICATIONS

System

Laser: Semiconductor laser

Transmission standards (Digital broadcasting): DVB-T

Channel coverage (Analogue broadcasting):

VHF: 170 MHz to 230 MHz

UHF: 470 MHz to 862 MHz

Channel coverage:

PAL (B/G, D/K, I)/SECAM (L)

VHF: E2 to E12, R1 to R12, F2 to

F10, Italian A to H, Ireland A to J,

South Africa 4 to 11, 13

UHF: E21 to E69, R21 to R69, B21 to

B69, F21 to F69

CATV: S01 to S05, S1 to S20, France

B to Q

HYPER: S21 to S41

The above channel coverage merely ensures the channel reception within these ranges. It does not guarantee the ability to receive signals in all circumstances. The channels that can be received differ depending on the country/region.

Video reception: Frequency synthesizer system

Audio reception: Split carrier system

Aerial out:

75-ohm asymmetrical aerial socket

Timer: Clock: Quartz locked/Timer indication: 24-hour cycle (digital)

Video recording format: MPEG-2, MPEG-1

Audio recording format/applicable

bit rate: Dolby Digital 2 ch

256 kbps/128 kbps (in EP, SLP, and

SEP mode), PCM

Inputs and outputs

LINE 2 OUT

(AUDIO): Phono jack/2 Vrms/10 kilohms

(VIDEO): Phono jack/1.0 Vp-p

(S VIDEO): 4-pin mini DIN/Y: 1.0 Vp-p,
C: 0.3 Vp-p (PAL)

LINE 2 IN

(AUDIO): Phono jack/2 Vrms/more than
22 kilohms

(VIDEO): Phono jack/1.0 Vp-p

(S VIDEO): 4-pin mini DIN/Y: 1.0 Vp-p,
C: 0.3 Vp-p (PAL)

LINE 3 – TV: 21-pin

CVBS OUT

S-Video/RGB OUT (upstream)

LINE 1/DECODER: 21-pin

CVBS IN/OUT

S-Video/RGB IN

Decoder

DV IN: 4-pin/i.LINK S100

DIGITAL OUT (COAXIAL): Phono
jack/0.5 Vp-p/75 ohms

COMPONENT VIDEO OUT

(Y, P_B/C_B, P_R/C_R):

Phono jack/Y: 1.0 Vp-p,

P_B/C_B: 0.7 Vp-p, P_R/C_R: 0.7 Vp-p

G-LINK*: mini jack

HDMI OUT: HDMI™ Connector

USB:

USB jack Type A (For connecting digital still camera, Memory card reader, USB memory and HDD camcorder)

USB jack Type B (For connecting PictBridge-compatible printers)

Conditional access module (RDR-HXD795/HXD895/HXD995/

HXD1095 only): CAM (Conditional Access Module) slot

General

Power requirements: 220-240 V AC, 50/60 Hz

Power consumption: 43 W

RDR-HXD790/HXD890/HXD990/

HXD1090: 47W (AEP, UK)

RDR-HXD890/HXD990: 47W (AUS)

RDR-HXD795/HXD895/HXD995/

HXD1095: 49W (AEP,UK)

AEP, UK Model: With CI card slot

Dimensions (approx.):

430 x 76.5 x 288 mm (width/height/
depth) incl. projecting parts

Hard disk drive capacity:

RDR-HXD790/HXD795: 120 GB

RDR-HXD890/HXD895: 160 GB

RDR-HXD990/HXD995: 250 GB

RDR-HXD1090/HXD1095: 500 GB

Mass (approx.): 4.7 kg

Operating temperature: 5°C to 35°C

Operating humidity: 25% to 80%

Supplied accessories:

Mains lead (1)

Aerial cable (1)*

Remote commander (remote) (1)

Set top box controller (1)

R6 (size AA) batteries (2)

*Two aerial cable are supplied for some models.

Specifications and design are subject to change without notice.

Refer to the SERVICE MANUAL of "RW6G/7G TRAVERSE MECHANISM REPAIR MANUAL" for Traverse Mechanism exchange.

DVD RECORDER

SONY®

Sony Corporation

Home Electronics Network Company

2008F1600-1

©2008.06

Published by Quality Assurance Dept.

TABLE OF CONTENTS

1. SERVICE NOTE	
1. DISK REMOVAL PROCEDURE IF THE TRAY CANNOT BE EJECTED (FORCED EJECTION)	1-1
2. BOARD CONNECTION, SERVICE REMOTE CONTROLLER	1-1
3. MODEL NAME SETTING METHOD WHEN ENGINE IS REPLACED	1-2
4. HOW TO DIAGNOSE HDD FAILURE	1-3
4-1. Defective HDD	1-3
4-2. HDD Recognition status	1-3
4-3. Display [E01] on FLD with unrecognized HDD	1-4
4-4. Display [E02] on FLD	1-5
4-5. When playing a video, MP3, or JPG, the contents freeze	1-5
4-6. Factory Check	1-6
4-7. Final Check	1-6
5. NOTICE OF TRAVERSE MECHA (TM) EXCHANGE	1-8
2. DISASSEMBLY	
2-1. UPPER CASE	2-2
2-2. TRAY COVER ASSEMBLY	2-2
2-3. FRONT PANEL BLOCK	2-3
2-4. FR-291 BOARD, FL-184 BOARD	2-3
2-5. DVD UNIT	2-4
2-6. DC FAN	2-5
2-7. HDD UNIT	2-5
2-8. BRACKET, DT	2-6
2-9. AV-133 BOARD	2-6
2-10. DT-124 BOARD	2-7
2-11. SWITCHING REGULATOR	2-7
2-12. CIRCUIT BOARDS LOCATION	2-8
3. BLOCK DIAGRAMS	
3-1. OVERALL BLOCK DIAGRAM	3-1
3-2. AV-133 BLOCK DIAGRAM	3-3
3-3. DT-124 BLOCK DIAGRAM	3-5
3-4. RD-066 BLOCK DIAGRAM	3-7
3-5. FR-291, FL-184 BLOCK DIAGRAM	3-9
3-6. POWER BLOCK DIAGRAM	3-11
4. SCHEMATIC DIAGRAMS AND PRINTED WIRING BOARDS	
4-1. FRAME SCHEMATIC DIAGRAM	4-1
4-2. SCHEMATIC DIAGRAMS	4-3
WAVEFORMS	4-3
• AV-133 (1/5) (IT CONTROLLER, IR) SCHEMATIC DIAGRAM	4-5
• AV-133 (2/5) (POWER/FAN CONT.) SCHEMATIC DIAGRAM	4-7
• AV-133 (3/5) (VIDEO/AUDIO) SCHEMATIC DIAGRAM	4-9
• AV-133 (4/5) (EURO) SCHEMATIC DIAGRAM	4-11
• AV-133 (5/5) (TUNER) SCHEMATIC DIAGRAM	4-13
• DT-124 (1/3) (EMMA2LL) SCHEMATIC DIAGRAM	4-15
• DT-124 (2/3) (CI) SCHEMATIC DIAGRAM	4-17
• DT-124 (3/3) (DIGITAL TUNER) SCHEMATIC DIAGRAM	4-19
• FR-291 (FL DRIVER, LINE 2 IN, FUNCTION SW) SCHEMATIC DIAGRAM	4-21
• FL-184 (DV, USB, REMOCON RECEIVER, POWER SW) SCHEMATIC DIAGRAM	4-23
• RD-066 (1/7) (POWER BLOCK) SCHEMATIC DIAGRAM	4-25
• RD-066 (2/7) (EMMA BLOCK) SCHEMATIC DIAGRAM	4-27
• RD-066 (3/7) (VIDEO/AUDIO BLOCK) SCHEMATIC DIAGRAM	4-29
• RD-066 (4/7) (MEMORY BLOCK) SCHEMATIC DIAGRAM	4-31
• RD-066 (5/7) (SATA/IDE IF) SCHEMATIC DIAGRAM	4-33
• RD-066 (6/7) (HDMI/DV/USB BLOCK) SCHEMATIC DIAGRAM	4-35
• RD-066 (7/7) (DVD DRIVE) SCHEMATIC DIAGRAM	4-37
• SWITCHING REGULATOR (SRV-2100EK) SCHEMATIC DIAGRAM	4-39
• SWITCHING REGULATOR (SRV-2057EK) SCHEMATIC DIAGRAM	4-41
4-3. PRINTED WIRING BOARDS	4-43
• FR-291 (FL DRIVER, LINE 2 IN, FUNCTION SW) PRINTED WIRING BOARD	4-43
• AV-133 (IT CONTROLLER, IR, POWER/FAN CONT., VIDEO/AUDIO, EURO, TUNER) PRINTED WIRING BOARD	4-45
• DT-124 (EMMA2LL, CI, DIGITAL TUNER) PRINTED WIRING BOARD	4-49
• RD-066 (POWER BLOCK, EMMA BLOCK, VIDEO/AUDIO BLOCK, MEMORY BLOCK, SATA/IDE IF, HDMI/DV/USB BLOCK, DVD DRIVE) PRINTED WIRING BOARD	4-53
• FL-184 (DV, USB, REMOCON RECEIVER, POWER SW) PRINTED WIRING BOARD	4-57
5. IC PIN FUNCTION DESCRIPTION	
5-1. IT CONTROL IC (IC101:LC87F06J2A-F59P6-E (AV-133 BOARD))	5-1
5-2. AV ENCODER/DECODER IC (IC1001:MC10050F1-505-LU1-A (RD-066 BOARD))	5-3
6. SERVICE MODE	
6-1. SERVICE MODE MAP	6-2
6-2. Diagnostic Mode	6-3
6-2-1. Model Setting	6-3
6-2-2. Service Mode	6-4
6-2-3. Version Information and Other Information (First screen)	6-4
6-2-4. RF Level Simplified Diagnosis (Subscreen1)	6-5
6-2-5. HDD Information for the HDD return sheet (Simplified measurement mode)	6-6
6-2-6. Cautions for handling the HDD	6-7
6-2-7. HDD Error Logging	6-9
6-2-8. ATA/ATAPI History - ERR	6-10
6-2-9. How to confirm HDD Access Flow	6-10
6-2-10. ATA/ATAPI Debugging Screen Second Screen and LD Deterioration Judgment (for writer)	6-11
6-2-11. History of VR Recording-related Errors	6-13
6-2-12. DV Service Mode	6-17
6-2-13. EPG Service Mode	6-19
6-2-14. Aging Mode	6-21
6-2-15. HDD Check Mode	6-22
6-3. Setup Related Menu	6-23
6-3-1. Firmware Downloading	6-23
6-3-2. Area-Specific Channel Setting	6-23
6-3-3. OSD Filter Setting	6-24

7. ADJUSTMENTS

7-1. Video System Adjustment 7-1

8. REPAIR PARTS LIST

8-1. EXPLODED VIEWS
8-1-1. OVERALL SECTION 8-1
8-1-2. CHASSIS SECTION 8-2
8-2. ELECTRICAL PARTS LIST 8-3

**SECTION 1
SERVICE NOTE**

1. DISK REMOVAL PROCEDURE IF THE TRAY CANNOT BE EJECTED (FORCED EJECTION)

1. Remove the upper case.
2. Insert the stiff wire in the hole and eject the tray.

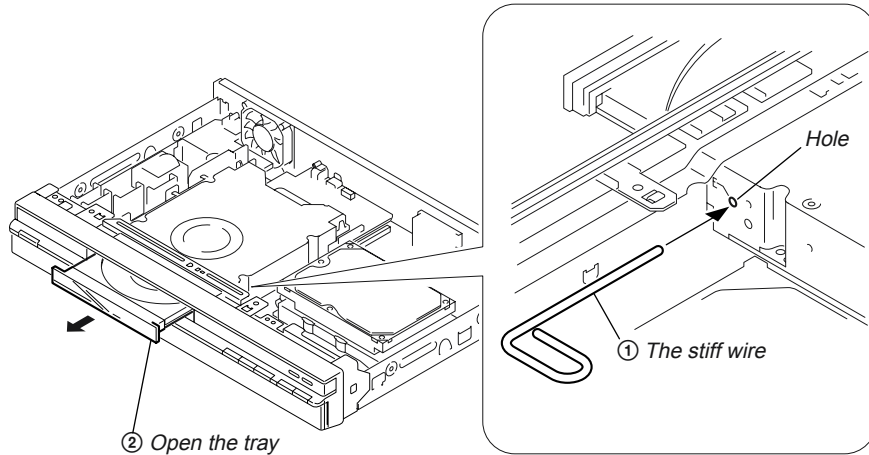

NOTES DURING THE FORCED EJECTION

1. If the forced ejection is executed while a blank disc media (DVD±RW, ±R) exists on the tray
 - Insert a DVD-ROM (DVD test disc, DVD software available on the market, or the like) in the tray and then close the tray

Note1: If you close the tray while it is empty, ejection of the tray becomes impossible.
Note2: If you close the tray with a CD disc inserted in it, the CD can be ejected. However, if you close the tray while it is empty, there can be a case that ejection of the tray becomes impossible.
Note3: Even if you replace the DVD drive unit while the tray remains under the state as described above, the situation cannot be improved.
2. If the tray cannot be ejected while the disc is not inserted
 - Execute the forced ejection.
 - Insert a DVD-ROM (DVD test disc, DVD software available on the market, or the like) on the tray and try to close the tray (There are cases that it recovers the trouble.)
3. Contents of forcibly ejected blank disc media (DVD±RW, ±R) can be damaged. (There can be a case that initialization is also impossible.)

2. BOARD CONNECTION, SERVICE REMOTE CONTROLLER

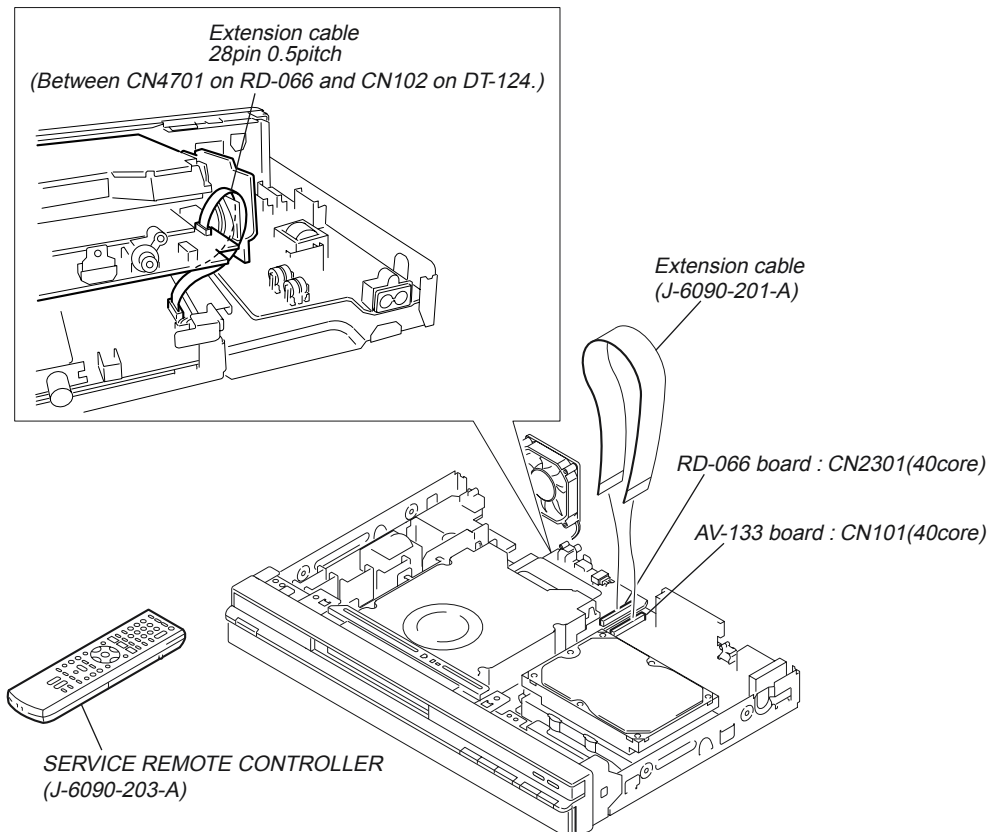

3. MODEL NAME SETTING METHOD WHEN ENGINE IS REPLACED

Required equipment:

- Remote controller (RMT-D2510/D251P)
- Service remote controller (Part code: J-6090-203-A)
- Monitor

Model name delete method

1. Turn the main POWER ON.
2. Press the following buttons on the service remote controller in this order.:
 “ESC” ⇨ “CHAP” ⇨ “1”
 * Confirm that the above operation is performed in the state that the screen has exited all settings such as “Home Menu” or “Simple Setting”.
3. Turn the main POWER OFF.
4. Turn the main POWER ON.
5. Find out the tentative model name from the Correspondence Table (Table 1) for the client machine. Then, enter the 4-digit “Input No.” on the screen using the service remote controller.
6. The model name setting method is complete. (Screen disappears.)
 * Upon completion of the model name setting, be sure to press both “ENTER” and “3” simultaneously on the service remote controller without fail. It sets the remote control code “3”.

Table1 Correspondence table between tentative model name and final product name

Model name	Tentative model name				
	AEP1	AEP2	AEP3	UK	AUS
RDR-HXD790	MRX-1740/EC1	—	MRX-1740/EC1	MRX-1740/CEK	—
RDR-HXD795	—	MRX-1745/EC2	—	—	—
RDR-HXD890	MRX-1760/EC1	—	MRX-1760/EC1	MRX-1760/CEK	MRX-1760/AU2
RDR-HXD895	—	MRX-1765/EC2	—	—	—
RDR-HXD990	MRX-1770/EC1	—	MRX-1770/EC1	—	MRX-1770/AU2
RDR-HXD995	—	MRX-1775/EC2	—	MRX-1775/CEK	—
RDR-HXD1090	MRX-1780/EC1	—	—	—	—
RDR-HXD1095	—	MRX-1785/EC2	—	MRX-1785/CEK	—

[Symptom]

If the following operation is performed, set won't be able to be restored.

[Remedy]

Must not be performed the following operation using service remote.
 If it is performed, set won't be able to be restored.
 And if set is broken by the operation, we can't guarantee the set when pressing in order of the following button.

- * [ESC]--> [STEREO]
- ([ESC]--> [Any button which is not described in SM])

Service remote controller (Part code: J-6090-203-A)



4. HOW TO DIAGNOSE HDD FAILURE

4-1. Defective HDD

There are four symptoms of defects in the HDD.

1. "E01" is displayed on the FLD.
(The HDD is unauthorized.)
2. "E02" is displayed on the FLD.
3. When playing a video, MP3, or JPG, contents freeze.
4. Irregular noises from the HDD

4-2. HDD Recognition status

How to enter Recognition status and sub screen mode.

- While the GUI screen is not displayed, use the service remote controller and press "ESC" key followed by "DISP" key.
- While the first screen is displayed, press "DIG/ANA" key repeatedly until the desired subscreen is displayed.
The subscreens change.

Service remote controller
(Part code: J-6090-203-A)



```

MRX-1635/EC1      VERSION : 1.01
SYSCON  : RELEASE 104
              Rev. 1. 5895
TUNERCON : 1.178           OK
DRIVE   : DVD-RW  DVR-L12X  OK
              1.00 OK
PIC SERIAL : 000800004940
HDD INT  : XXXXXXXXXXXXXXXX 250
HDD USE  :                   250

DEVICE : E2R-FEx1.0   FLASH : 64M
REGION : 2             C : 0000400259
                      HDCP : 0000400259
    
```

• Details on HDD data are described below:

- Sample 1: (For the DVD recorder of 120GB)
HDD INT: XXXXXXXXXXXXXXXX 160
HDD USE: 120
- Sample 2: (For the DVD recorder of 160GB)
HDD INT: XXXXXXXXXXXXXXXX 160
HDD USE: 160
- Sample 3: (For the DVD recorder of 250GB)
HDD INT: XXXXXXXXXXXXXXXX 250
HDD USE: 250
- Sample 4: (For the DVD recorder of 500GB)
HDD INT: XXXXXXXXXXXXXXXX 500
HDD USE: 500

The item [HDD USE] indicates the HDD capacity of the DVD recorder specifications.
Check if the value matches with the specifications of the DVD recorder.

FL Display	OS Display	HDD identification conditions	Details on HDD data are described below.	Remarks
REPAIR	"Repairing the HDD". ↓ "HDD repair is complete".			
E01	An error occurred. Please consult your nearest Sony dealer. Note that contents on the HDD may be erased when servicing this unit.	Failure to physically identify the HDD (no connection, defective HDD, interface error). Physical identification of HDD possible, but not identified	Blank space WDC 10234564 # 160	Check the connection to the SATA cable and power cable. Replace the SATA cable or power cable. Replace the HDD. Replace the FE or part in the SATA/ATA communication. "#" indicates that the HDD is unauthorized.
E02	The Hard Disk Drive info is incorrect. Use the Disk Setup menu to reformat.	Physical identification of HDD possible, HDD identified, but failure in logical formatting.	WDC 10234564 ! 160	"!" indicates an HDD authorization error. Initialize the HDD.
Normal		Physical identification of HDD possible, HDD identified, and correct logical formatting (HDD correctly identified).	WDC 10234564 160	

4-3. Display [E01] on FLD with unrecognized HDD

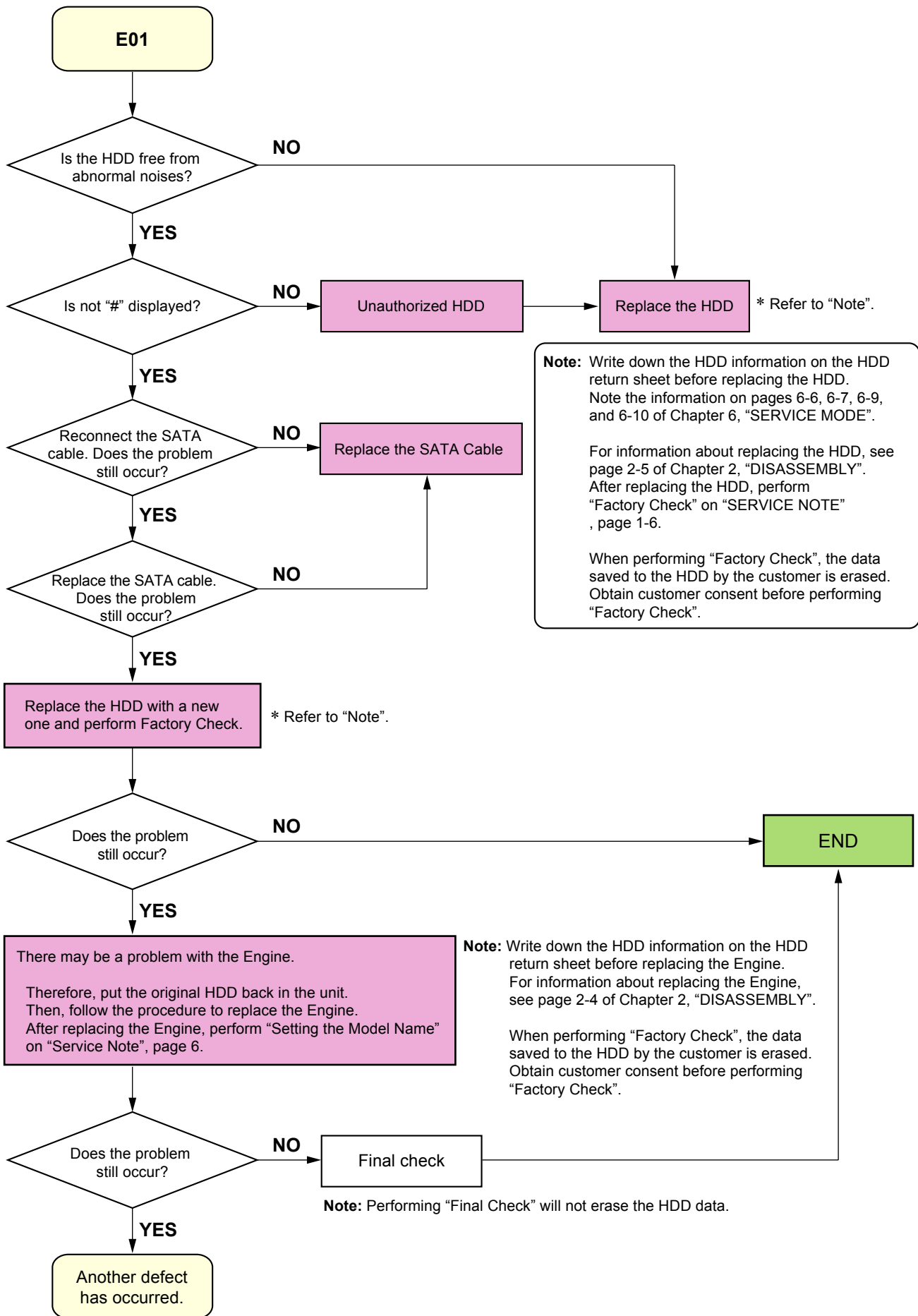

4-4. Display [E02] on FLD

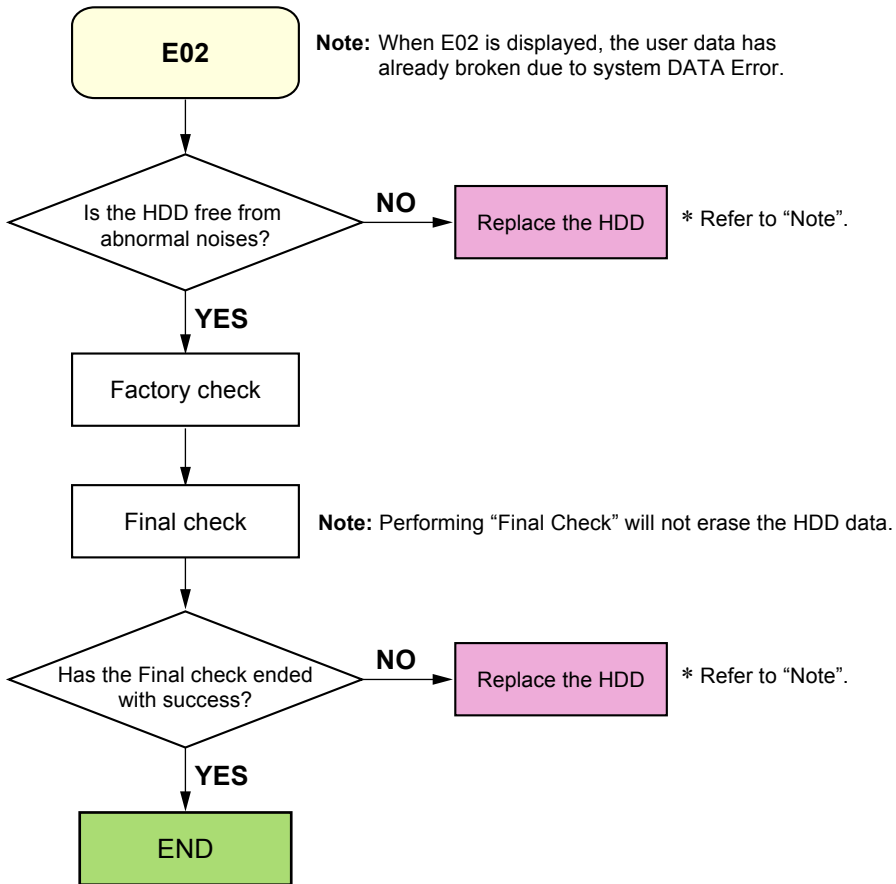

4-5. When playing a VIDEO, MP3, or JPG, the contents freeze

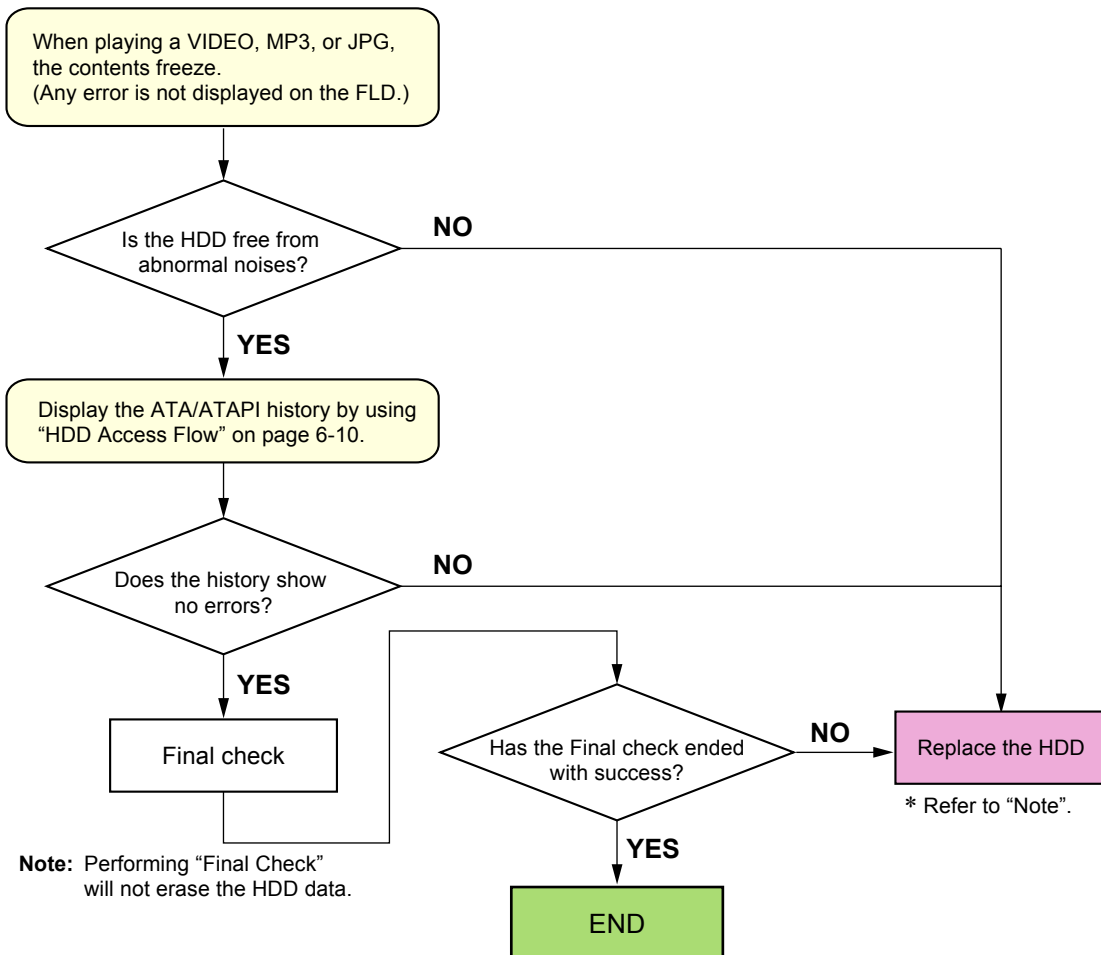

4-6. Factory Check

1. Pull out and then reconnect the AC cable.
2. Press “ESC” key followed by “P.RUN” key to start Formatting.
3. When “B COMPLETE” appears, the Factory Check is complete.
4. Press “Power” button. The unit starts normally.

When “Factory Check” has finished completely without error , reset “Recording Error History” and “ATA/ATAPI History Error” with the Clear key.

Recording Error History Display

```
07-03-19 12:36:06 ESFSYS INIT
07-03-19 12:36:06 HDD Zero MR
07-03-19 12:36:06 HDD Initialize
07-03-19 12:36:06 HDD Zero MR
07-03-19 12:27:27 Status NG
```

Note: Write down the HDD information on the HDD return sheet before replacing the HDD.
Note the information on pages 6-6, 6-7, 6-9, and 6-10 of Chapter 6, “SERVICE MODE”.

When performing “Factory Check”, the data saved to the HDD by the customer is erased.
Obtain customer consent before performing “Factory Check”.

“Recording Error History” and “ATA/ATAPI History Error”, see pages 6-9, 6-10 of Chapter 6, “SERVICE MODE”.

4-7. Final Check

4-7-1. SELF TEST (SMART TEST)

This is a simplified diagnosis for the HDD.

A serious failure in the HDD can be detected with this test.

Time required for testing: Approx. 60 sec.

How to start/terminate the diagnostic program

Use the remote control unit for servicing.

- How to start: Press the following keys in this order; “ESC”, “CX”, “0”, and “1” keys. (refer to 6-2-15)
- How to terminate: Press “ESC” key.

HDD CHECK MODE [1-4]

- 1 HDD Information
- 2 S.M.A.R.T Attribute Information
- 3 S.M.A.R.T DST
- 4 HDD R/W Check

Execute Self-Test.

- Press “3” key on the remote control unit for servicing while the menu screen is displayed.
- When the following screen is displayed, press “1” key to start the Self-Test.



Note: “2. Exe Ext Self Test” is not used.

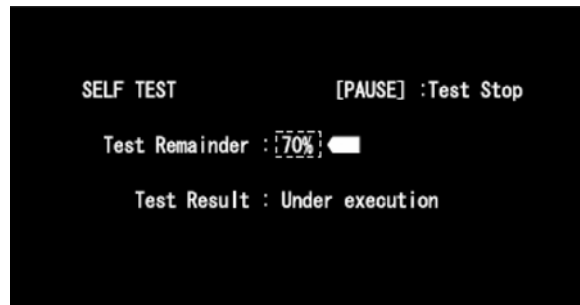

Note: Performing “Self Test” will not erase the HDD data.

Diagnosis results

- Without an error: “. . . Completed” is displayed. Then, proceed to the Extended Self-Test.
- With an error: “. . . Error” is displayed. Look at the number in Test Result. If the place value for tens is 1 or 2, execute the Self-Test again. If it is from 3 to 7, the HDD must be replaced.

Note: If the result of the second test is the same, replacement of the HDD is required.

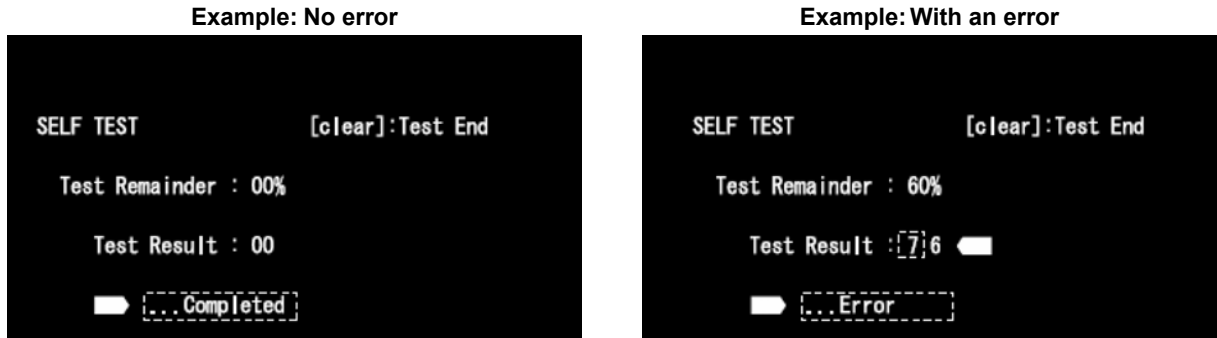

4-7-2. Performance Check

Press “ESC” key, then “A.MON” key.

This is a reading test across all sectors of the HDD.
 Data recorded on the HDD will not be erased, because no writing operation is performed.
 Time required for testing: Approx. 45 min/160 G
 75 min/250 G
 130 to 150 min/500 G

When “Performance Check” finishes completely without error, reset “ATA/ATAPI History Error” with the Clear key.

**FL display specification
 HDD factory Check**

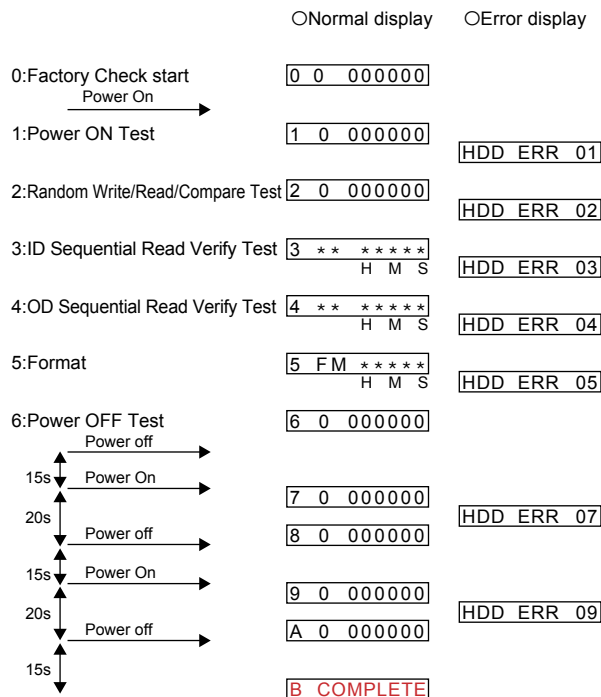

HDD performance Check

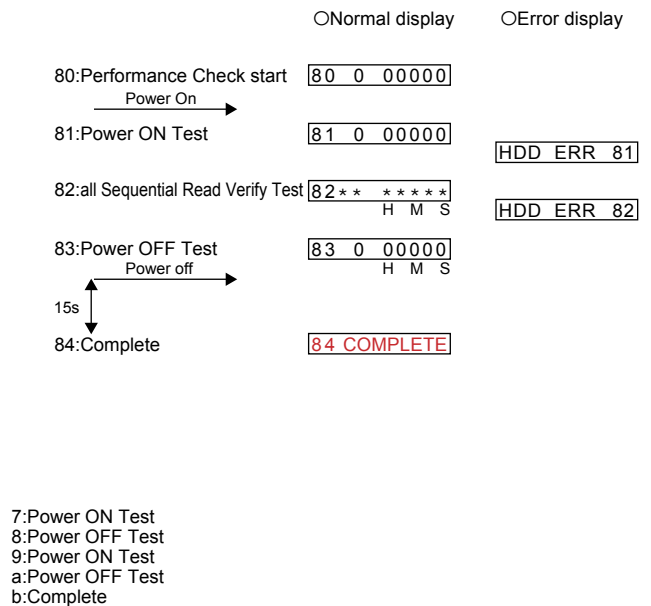
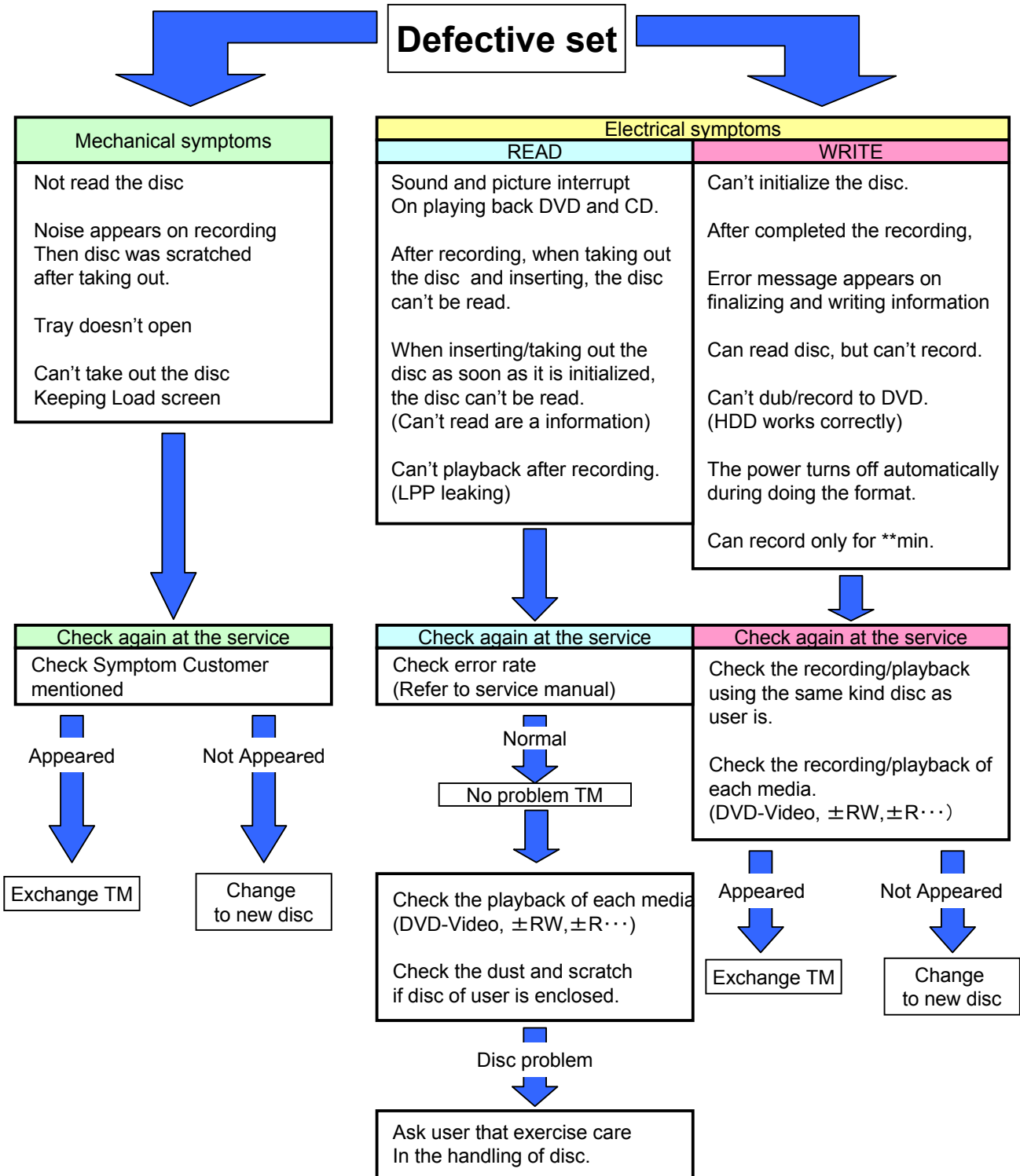

Fig 1. FL Display Flow

* The logo for “Factory Check” and “Performance Check” is recorded in “ATA/ATAPI History Error”.

5. Notice of traverse mecha (TM) exchange.

Distinguish the symptom according to the following procedure



For TM exchange, refer to SM below.

Service manual: RW6G/7G TRAVERSE MECHANISM REPAIR MANUAL(9-885-951-1*)

How to get it: 1. Open Service manual home page of ESI.

2. Input RW6G into "Model Name".

3. Click "Search" button.

RDR-HXD790/HXD795/HXD890/HXD895/HXD990/HXD995/HXD1090/HXD1095
SECTION 2
DISASSEMBLY

NOTE: The following flow chart shows the disassembly procedure.

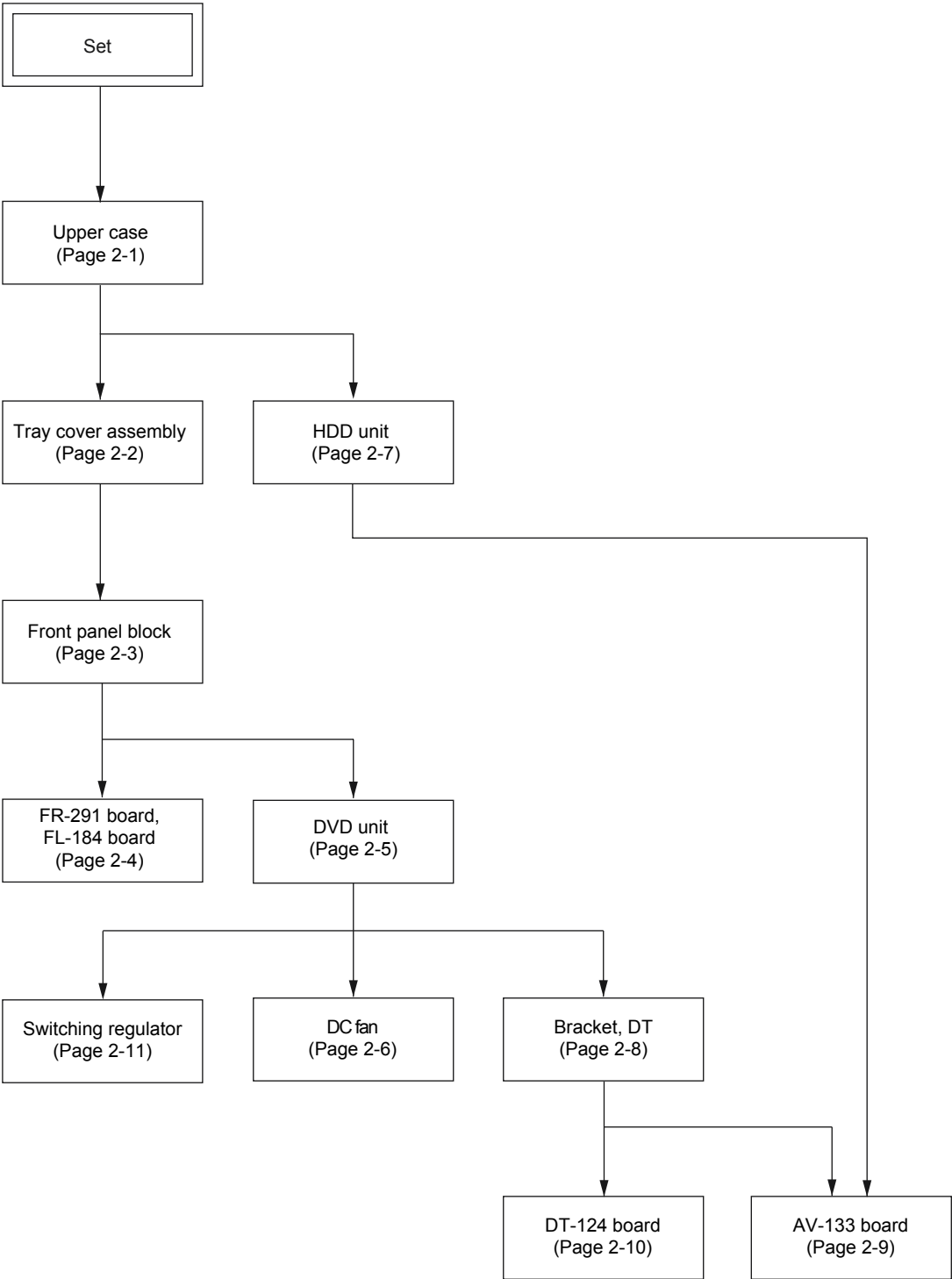

NOTE: Follow the disassembly procedure in the numerical order given.

2-1. UPPER CASE

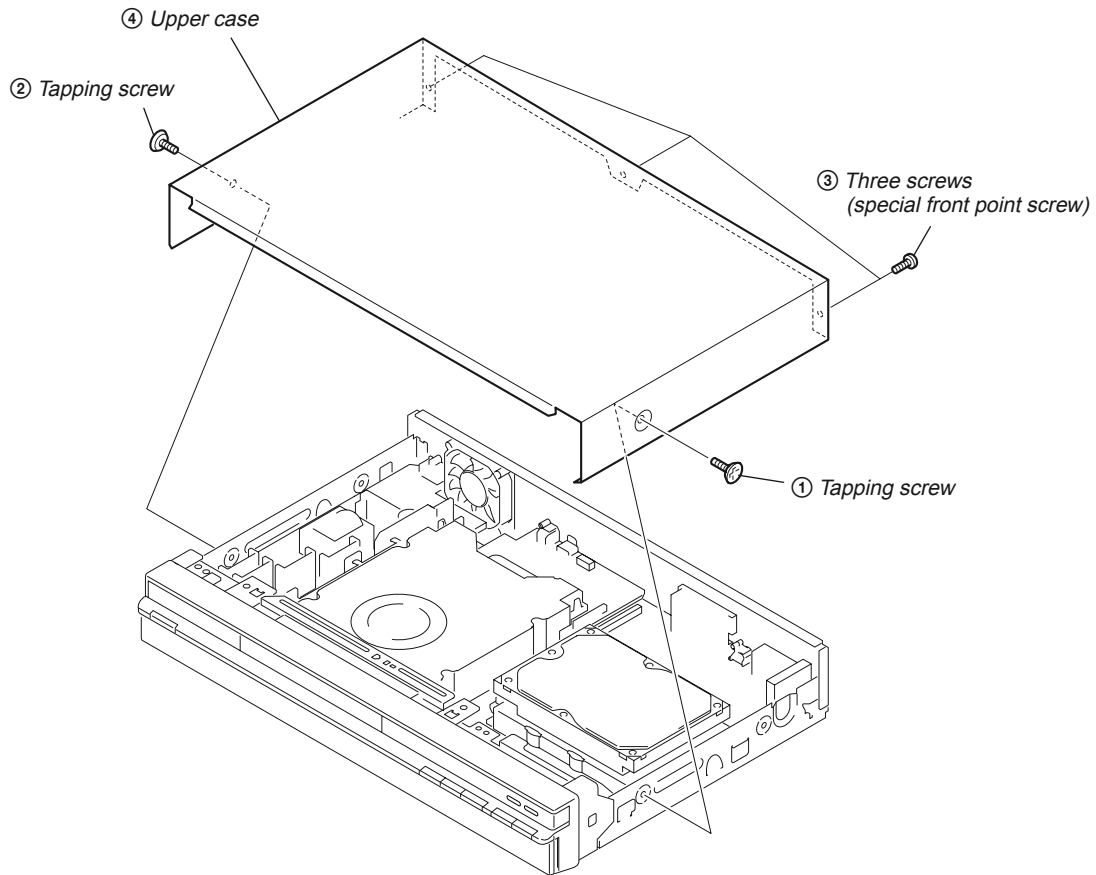

2-2. TRAY COVER ASSEMBLY

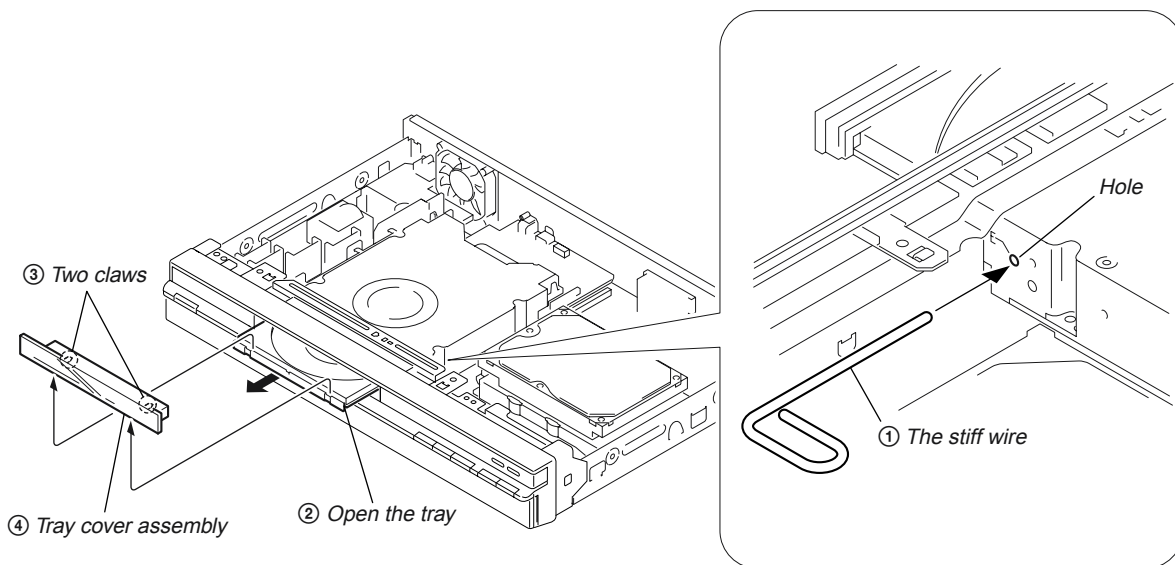

2-3. FRONT PANEL BLOCK

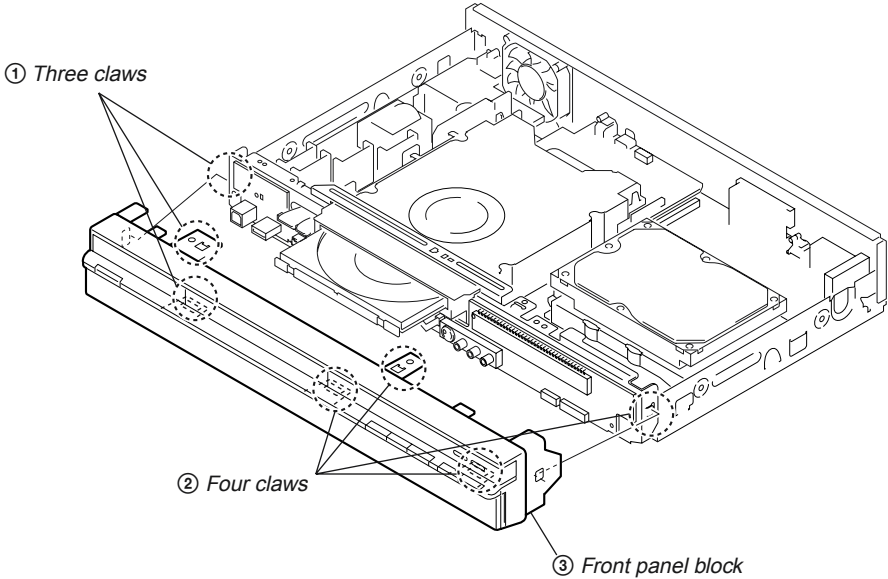

2-4. FR-291 BOARD, FL-184 BOARD

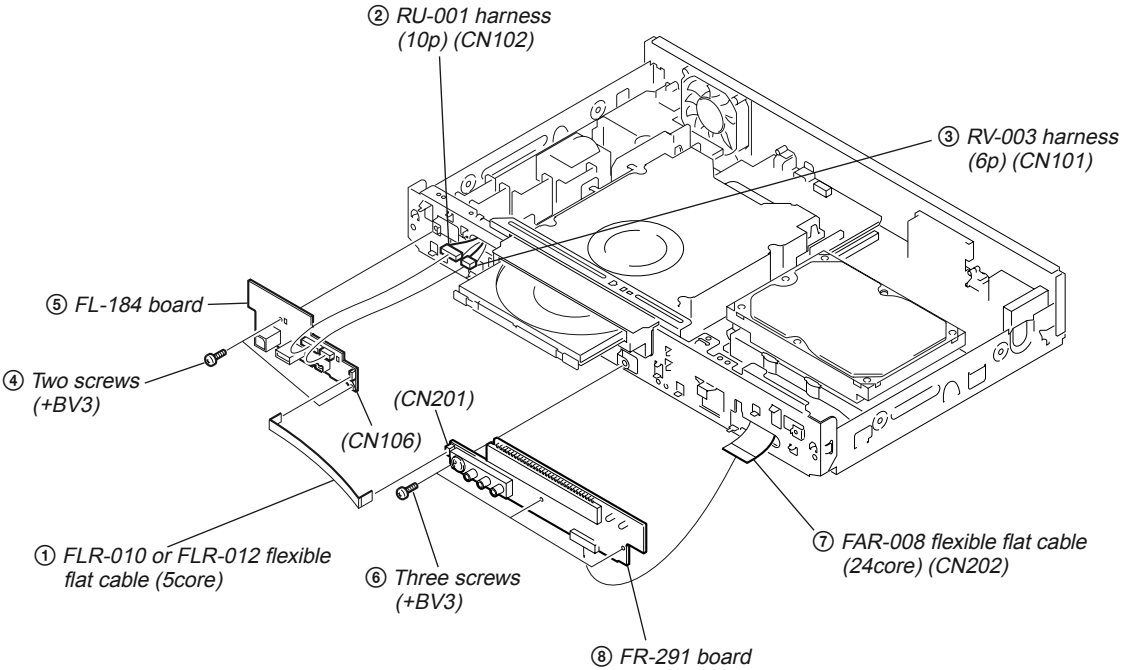

2-5. DVD UNIT

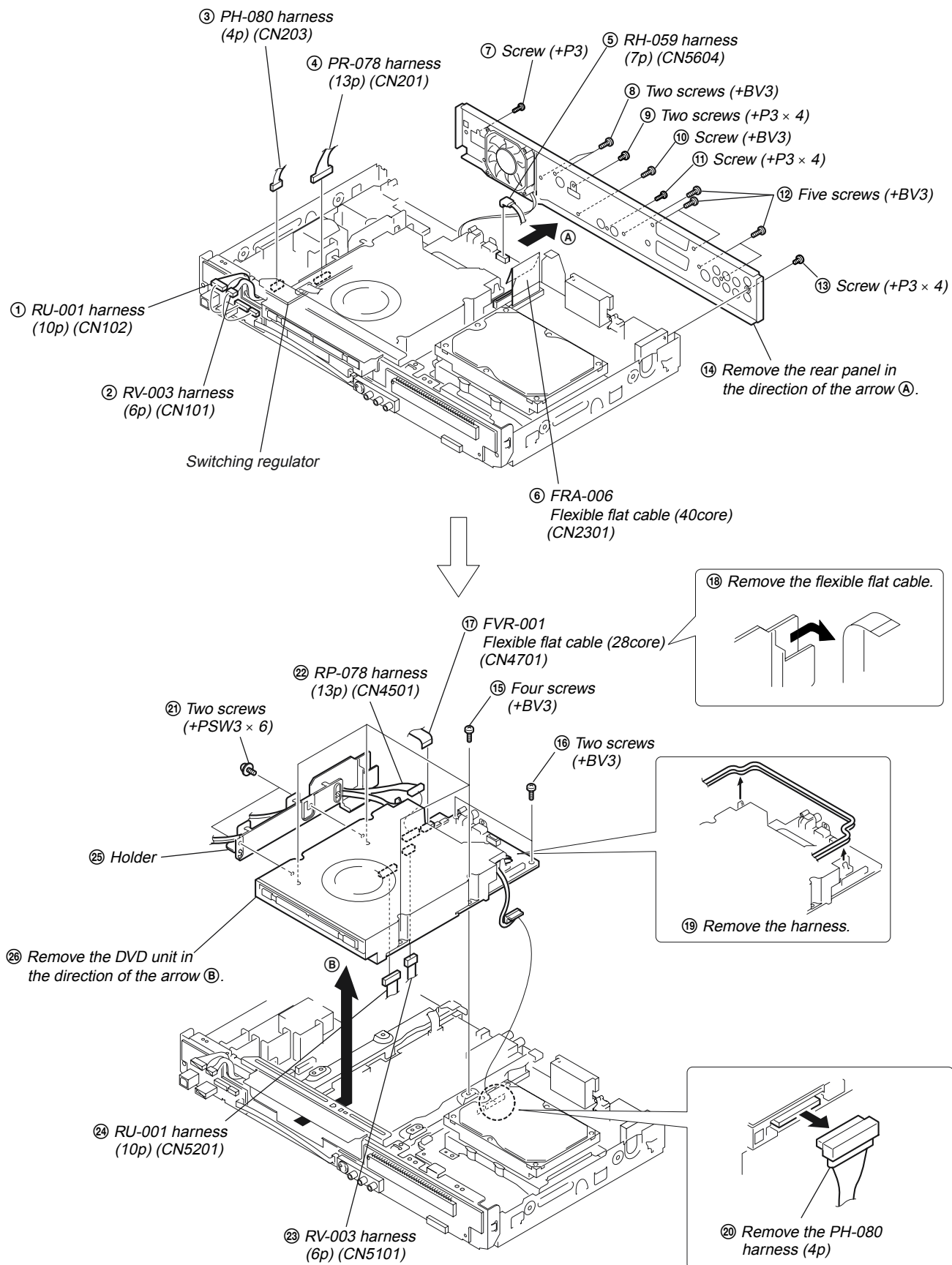

2-6. DC FAN

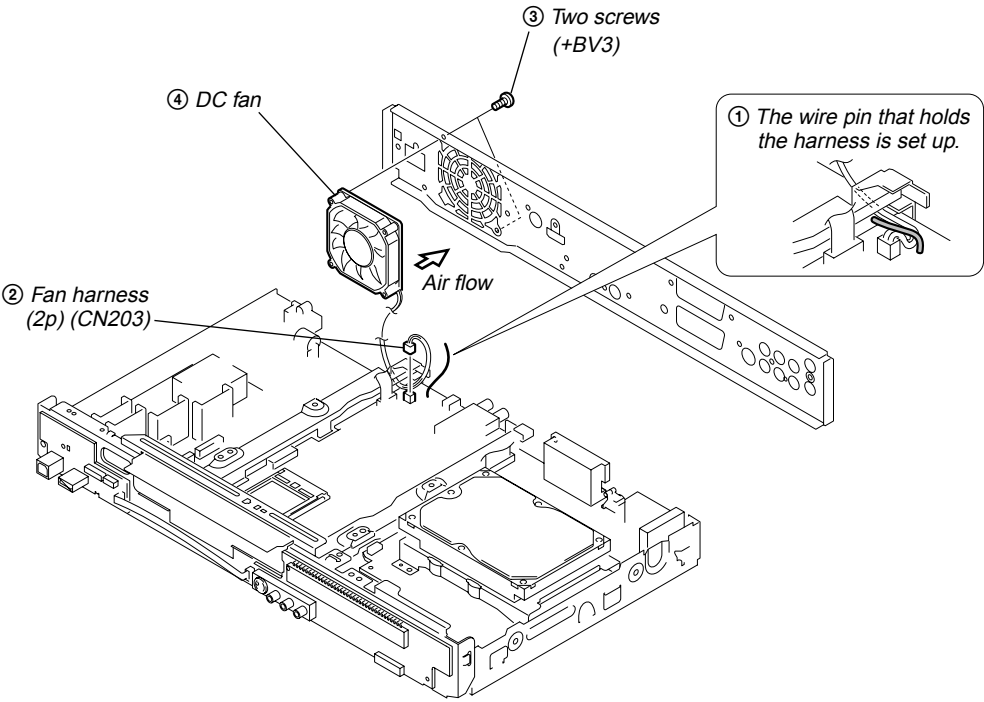

2-7. HDD UNIT

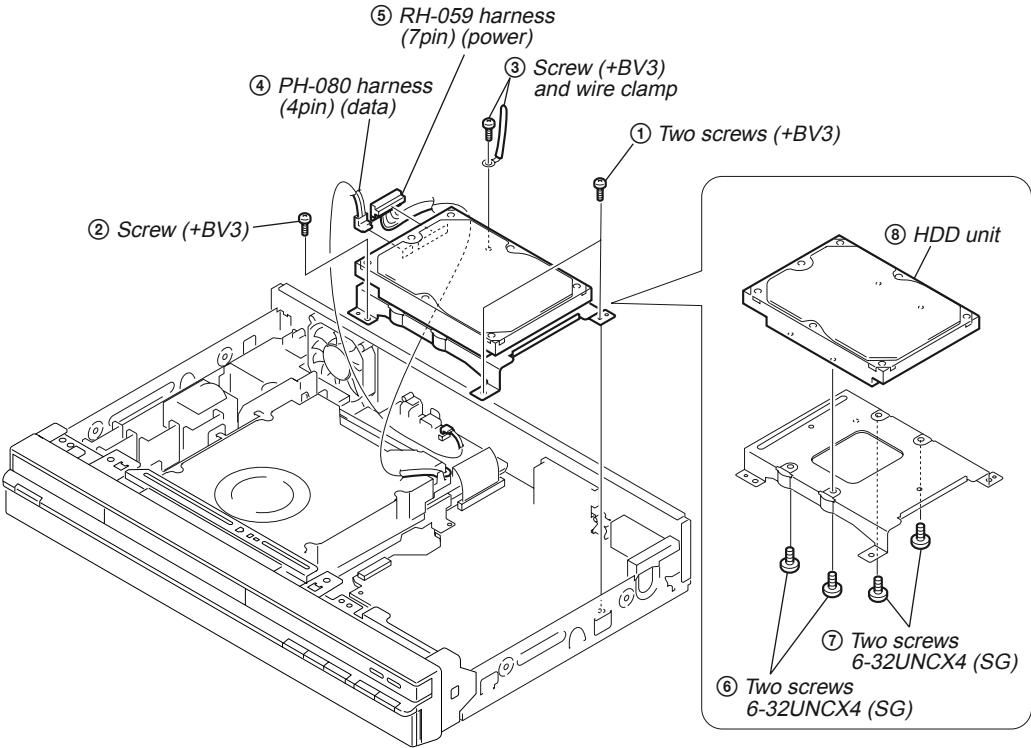

2-8. BRACKET, DT

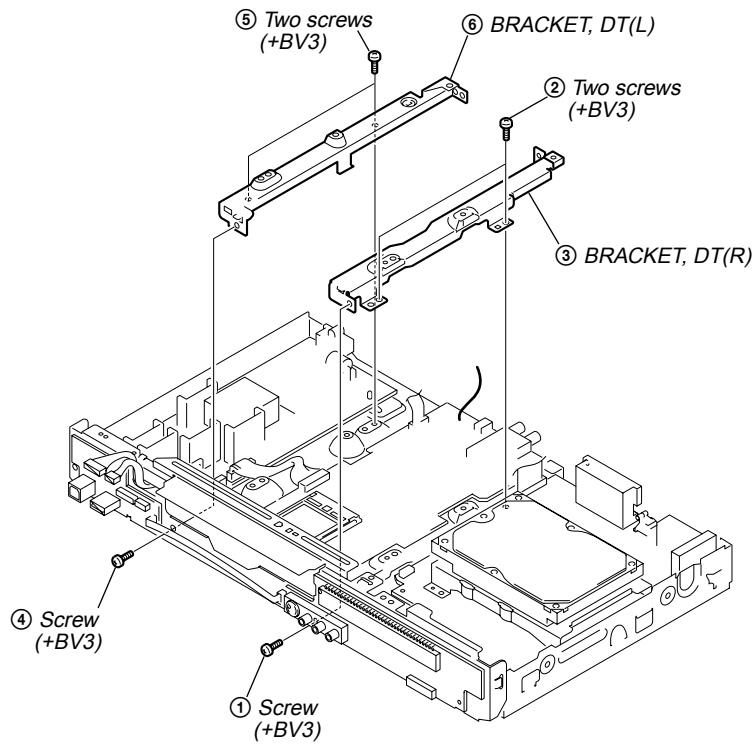

2-9. AV-133 BOARD

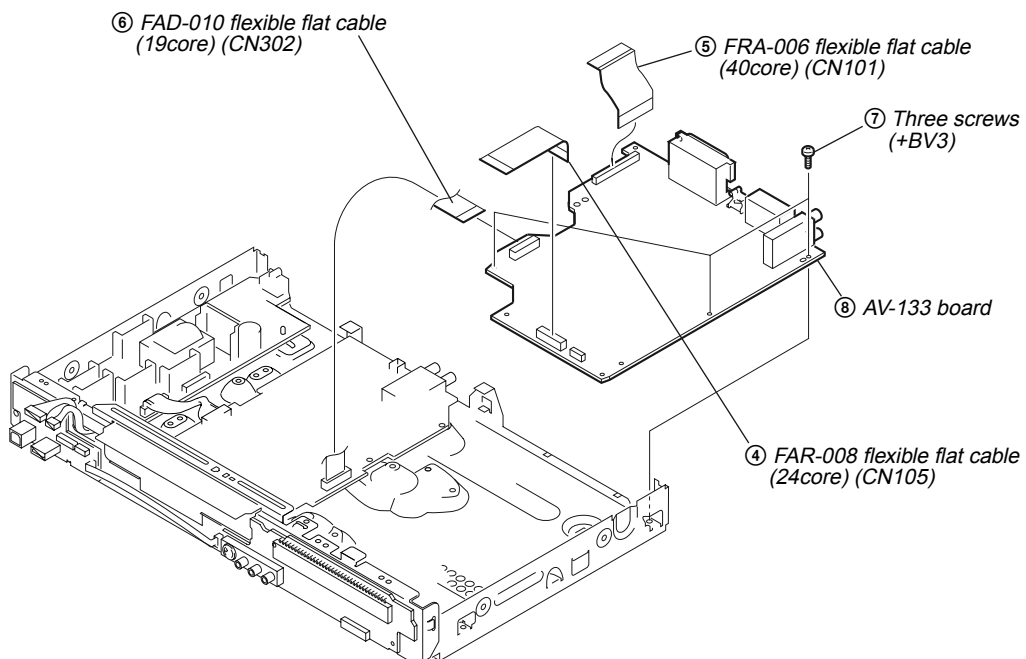

2-10.DT-124 BOARD

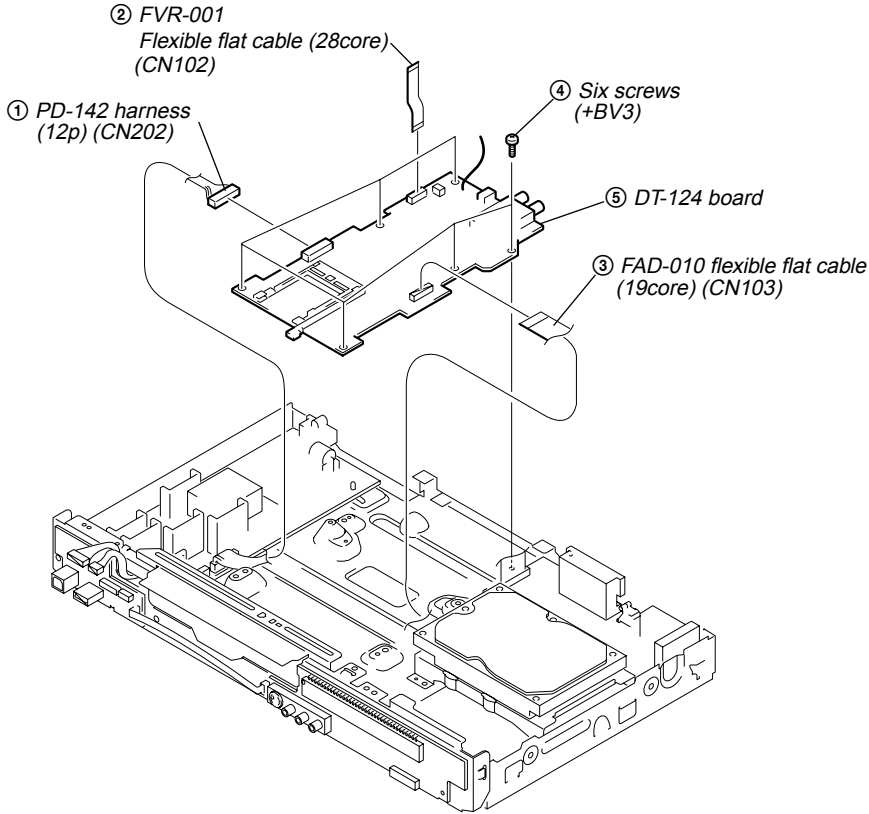

2-11. SWITCHING REGULATOR

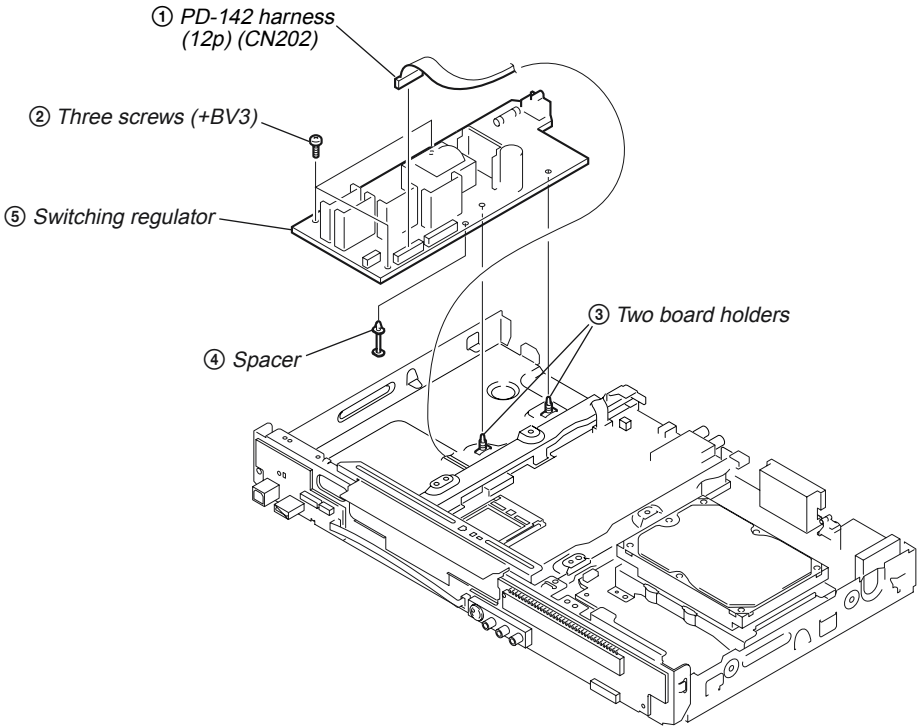

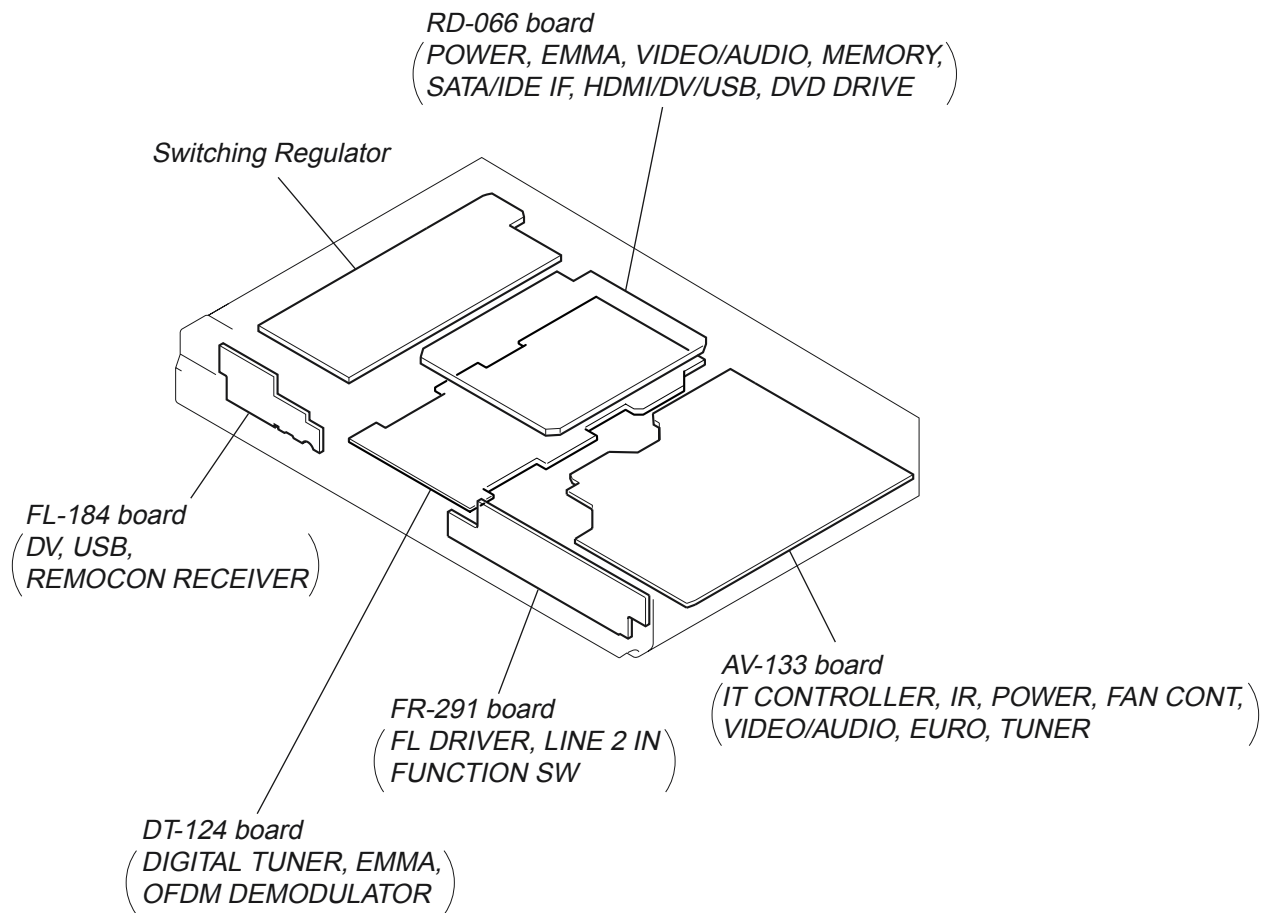

2-12. CIRCUIT BOARDS LOCATION

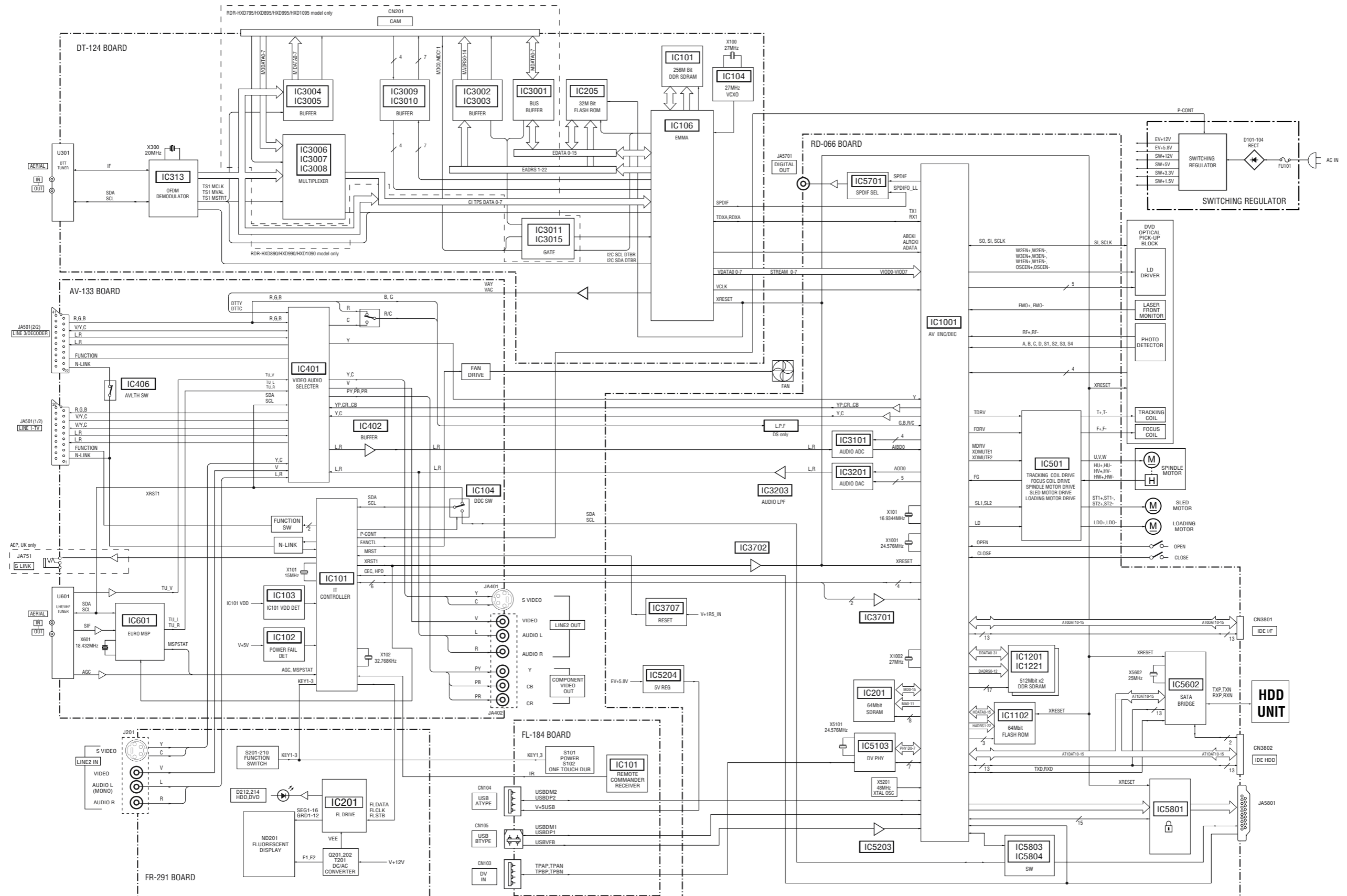

SECTION 3
BLOCK DIAGRAMS

3-1. OVERALL BLOCK DIAGRAM



Note1: The HDMI block is highly confidential, and prohibited from releasing to public.
 Note2: The components identified by mark  contain confidential information.
 Strictly follow the instructions whenever the components are repaired and/or replaced.

3-2. AV-133 BLOCK DIAGRAM

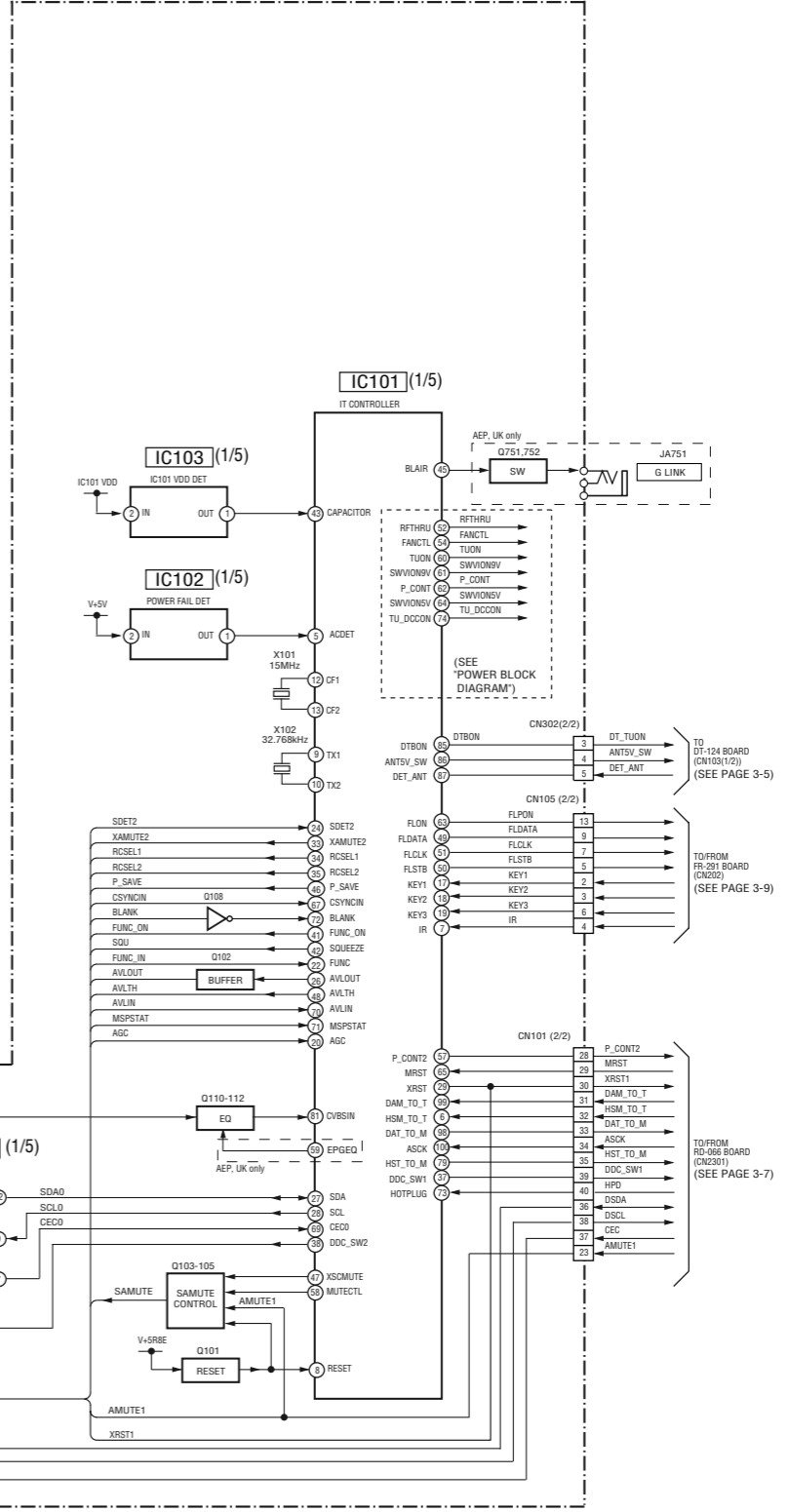
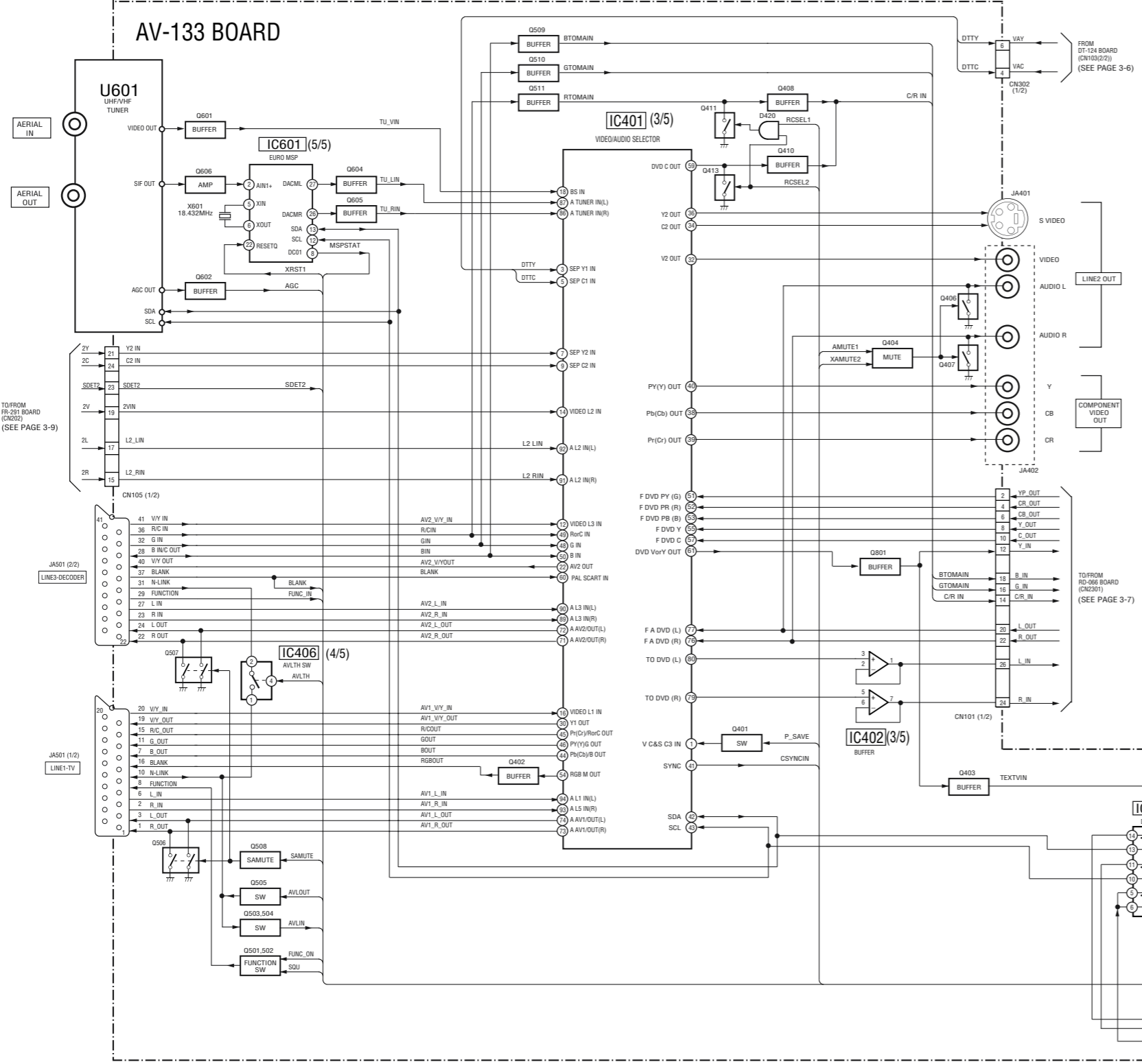

3-3. DT-124 BLOCK DIAGRAM

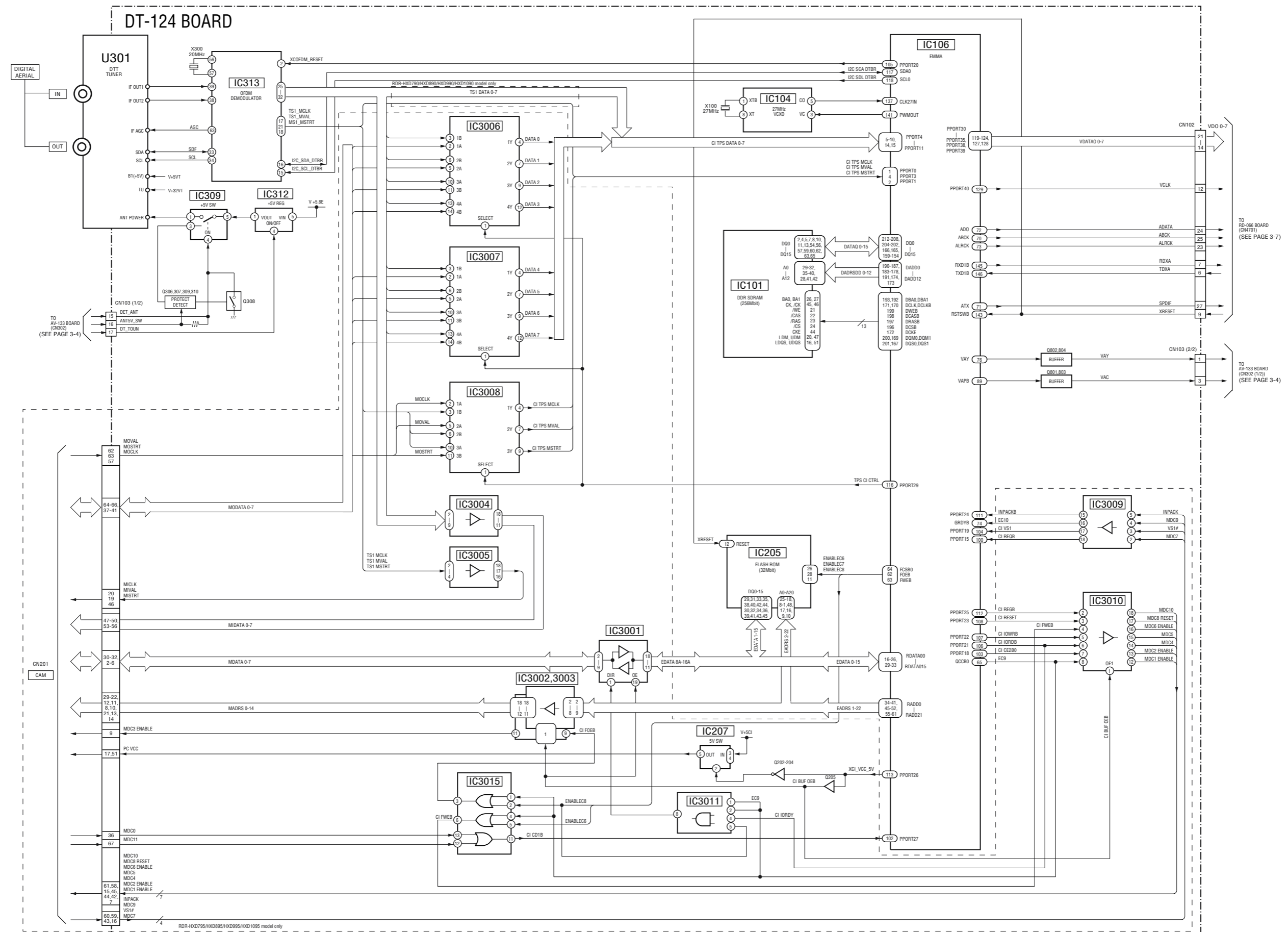

3-4. RD-066 BLOCK DIAGRAM

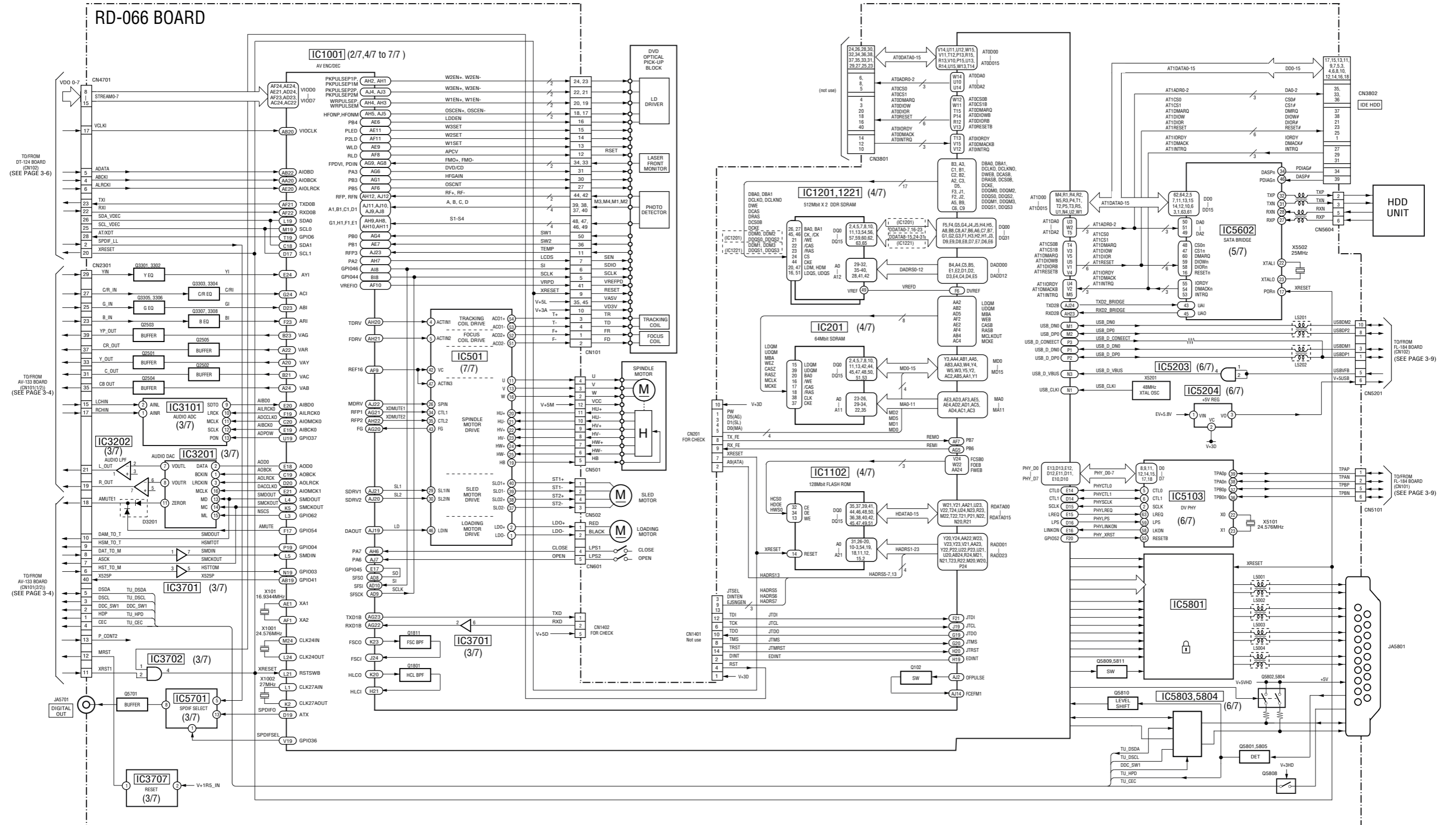

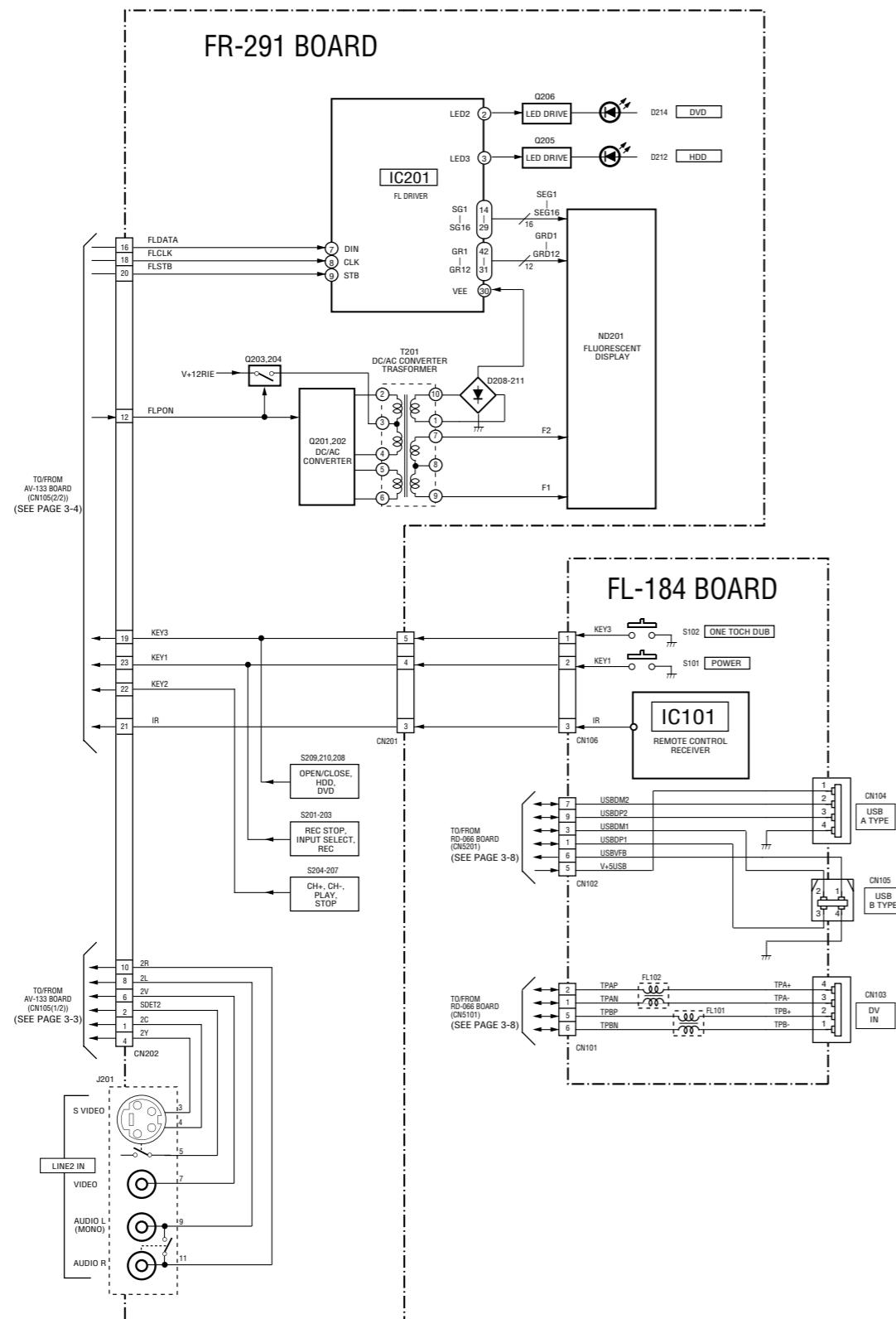

Note: The HDMI block is highly confidential, and prohibited from releasing to public. The components identified by mark contain confidential information. Strictly follow the instructions whenever the components are repaired and/or replaced.

3-5. FR-291, FL-184 BLOCK DIAGRAM

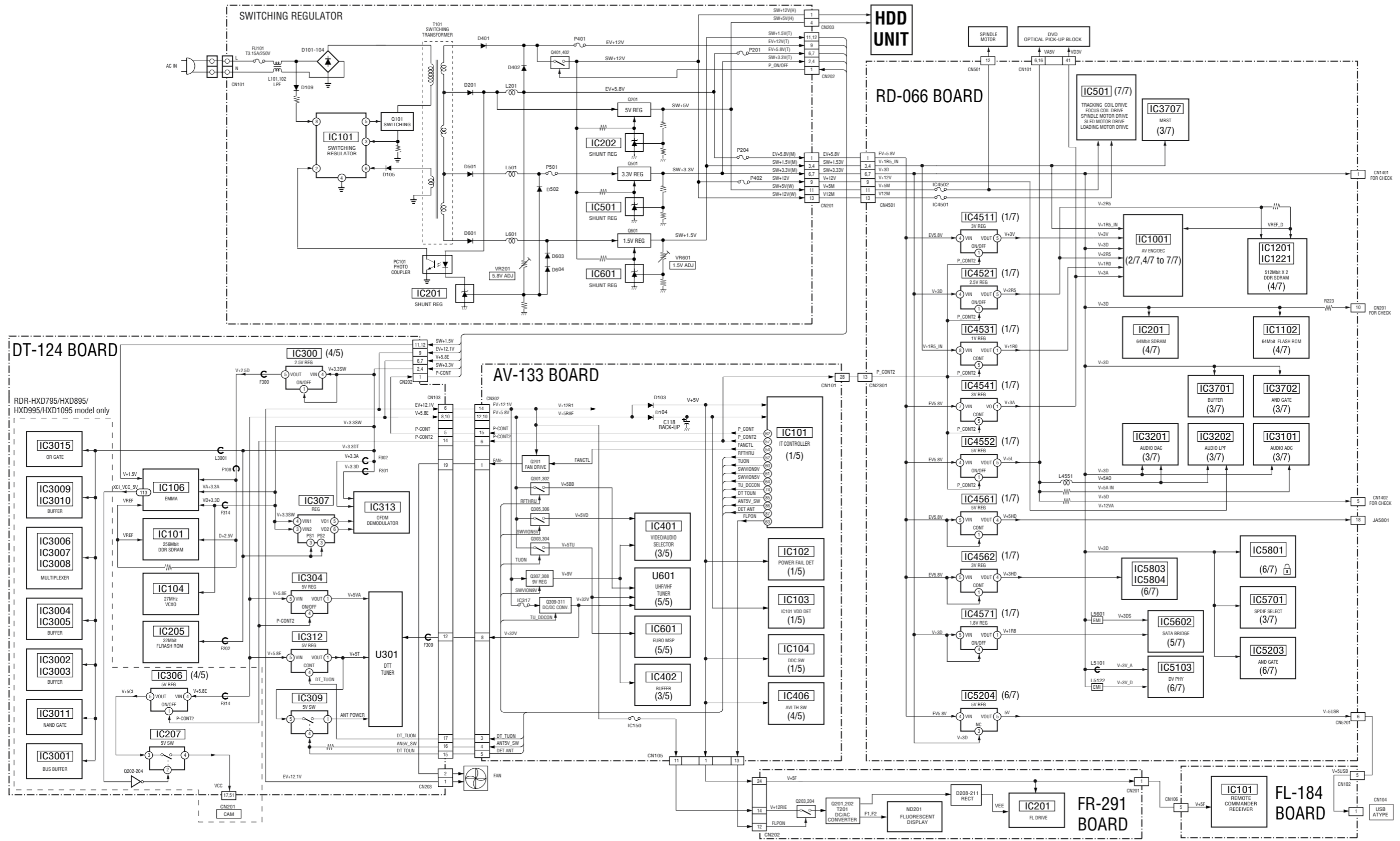

3-6. POWER BLOCK DIAGRAM



Note1: The HDMI block is highly confidential, and prohibited from releasing to public.
Note2: The components identified by mark  contain confidential information.
 Strictly follow the instructions whenever the components are repaired and/or replaced.

SECTION 4
SCHEMATIC DIAGRAMS AND PRINTED WIRING BOARDS

4-1. FRAME SCHEMATIC DIAGRAM

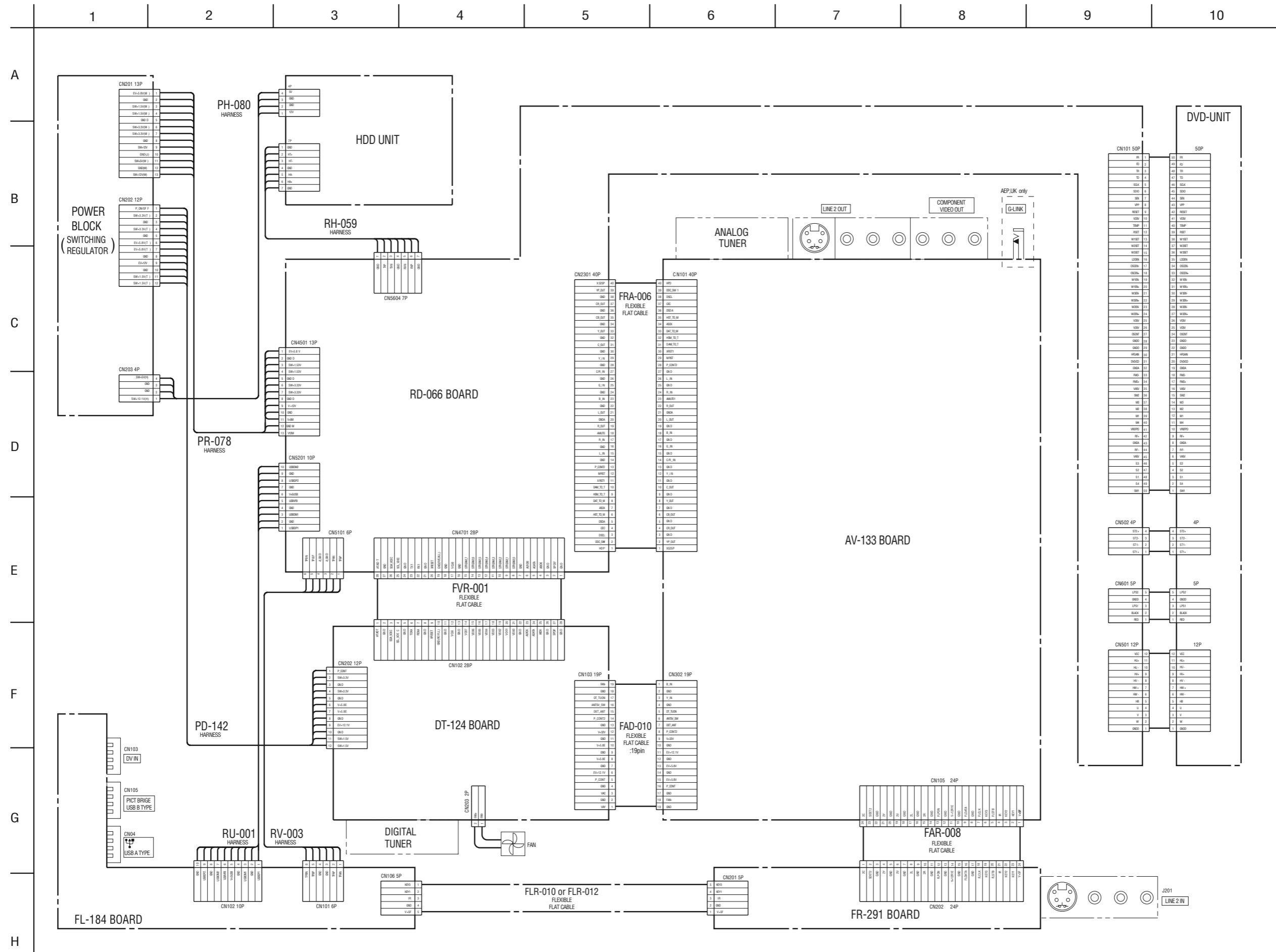

4-2. SCHEMATIC DIAGRAMS

THIS NOTE IS COMMON FOR SCHEMATIC DIAGRAMS
(In addition to this, the necessary note is printed in each block)

(For printed wiring boards)

- : Uses unlead solder.
- : Pattern from the side which enables seeing. (The other layers' patterns are not indicated)
- Through hole is omitted.
- There are a few cases that the part printed on diagram isn't mounted in this model.
- : panel designation

(For schematic diagrams)

- All capacitors are in μF unless otherwise noted. pF : μpF . 50V or less are not indicated except for electrolytics and tantalums.
- All resistors are in ohms 1/4W (Chip resistors : 1/10W) unless otherwise specified. $\text{k}\Omega=1000\Omega$, $\text{M}\Omega=1000\text{k}\Omega$.
- Caution when replacing chip parts. New parts must be attached after removal of chip. Be careful not to heat the minus side of tantalum capacitor, because it is damaged by the heat.
- All variable and adjustable resistors have characteristic curve B, unless otherwise noted.
- : non flammable resistor
- : fusible resistor
- : panel designation
- Δ : internal component
- : adjustment for repair
- \triangleright : IN/OUT direction of (+/-) B line
- : B+ Line
- : B- Line
- Circled numbers refer to waveforms.
- Voltages are dc between measurement point and ground.

Note : The components identified by mark Δ or dotted line with mark Δ are critical for safety. Replace only with part number specified.

When indicating parts by reference number, please include the board name.

Chip parts.

Transistor

Diode

WAVEFORMS

RD-066 BOARD

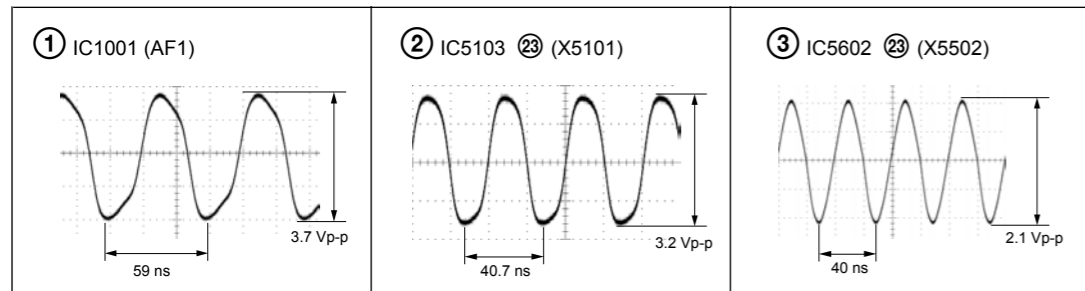

FR-291 BOARD

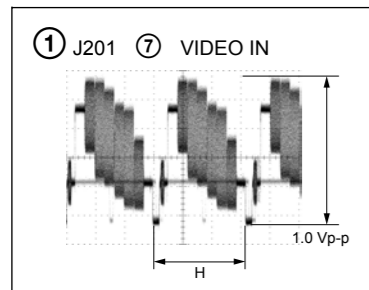

DT-124 BOARD

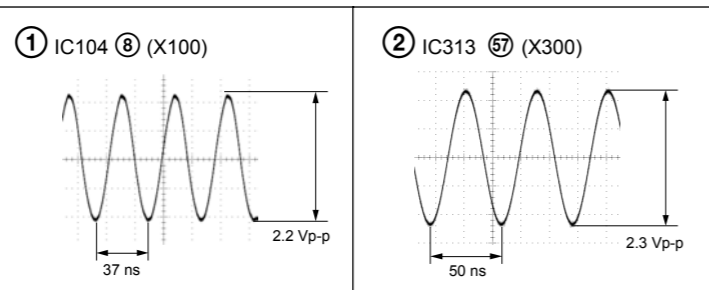

AV-133 BOARD

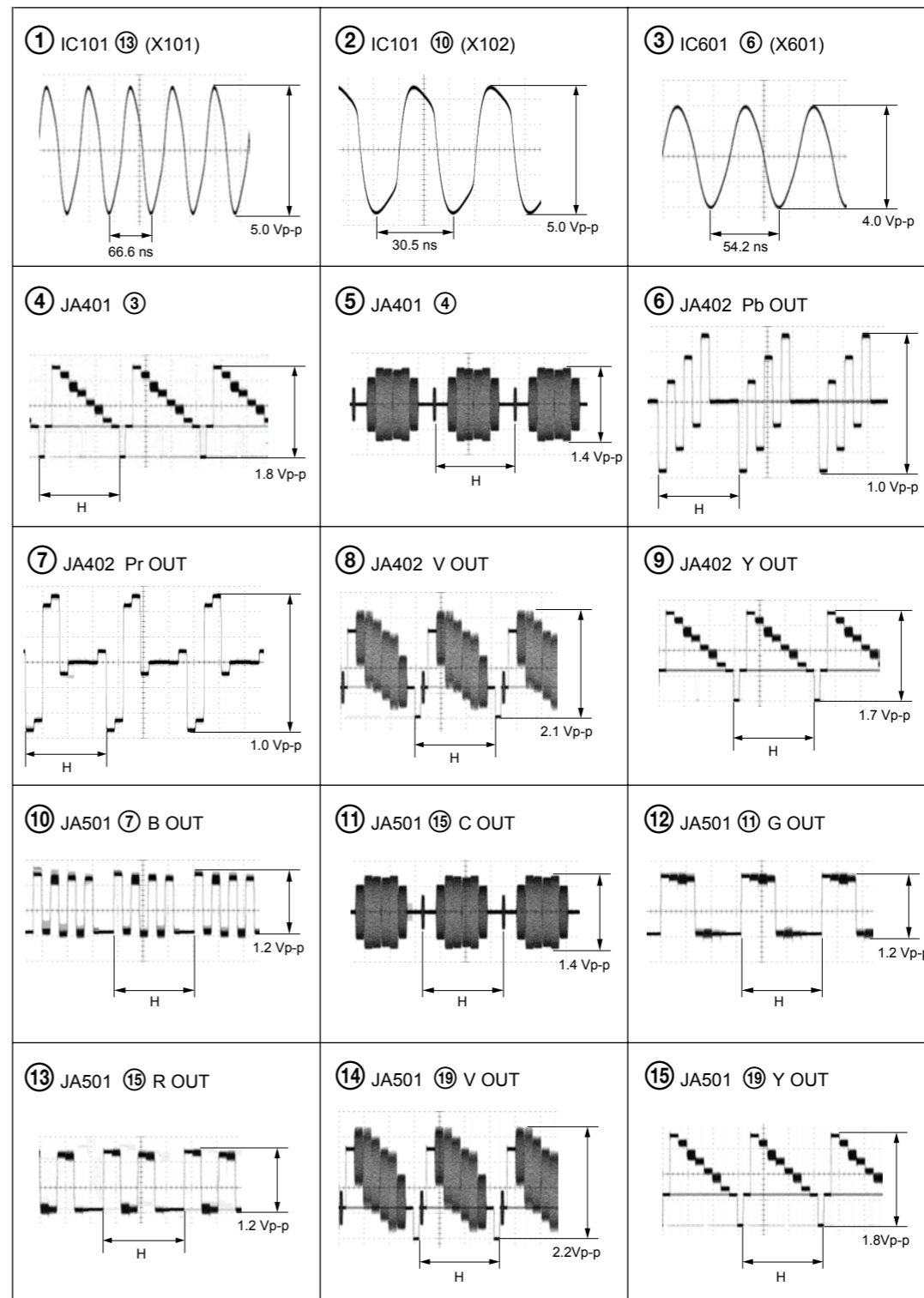

For Schematic Diagram

- Refer to page 4-4 for waveforms.
- Refer to page 4-43 for printed wiring board.

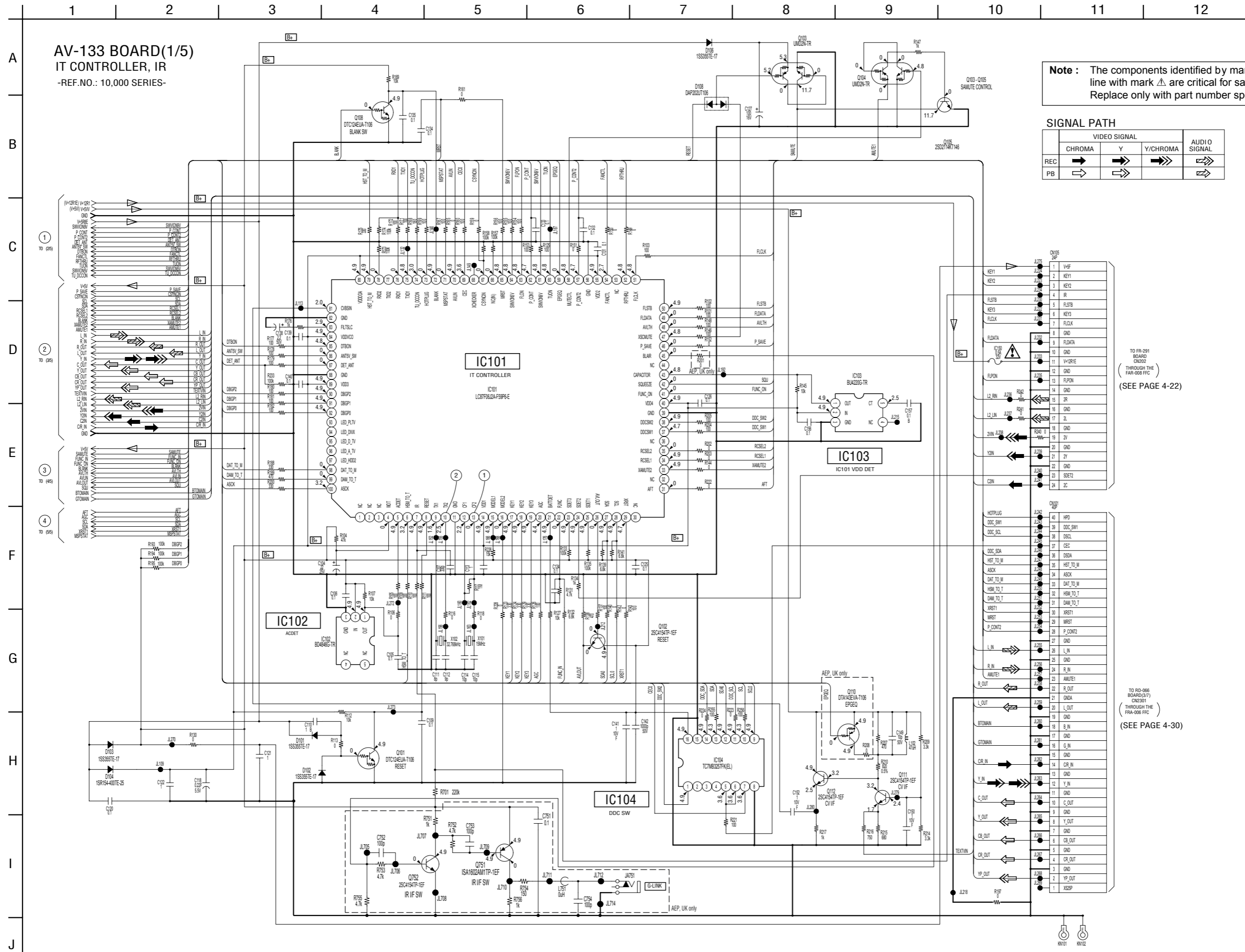

Note : The components identified by mark Δ or dotted line with mark Δ are critical for safety. Replace only with part number specified.

SIGNAL PATH

REC	VIDEO SIGNAL			AUDIO SIGNAL
	CHROMA	Y	Y/CHROMA	
PB	→	⇒	⇒⇒	⇒⇒⇒

TO FR-201 BOARD (CN202) THROUGH THE FRA-008 FFC (SEE PAGE 4-22)

TO RD-066 BOARD(3/7) CN201 THROUGH THE FRA-006 FFC (SEE PAGE 4-30)

For Schematic Diagram
 • Refer to page 4-43 for printed wiring board.

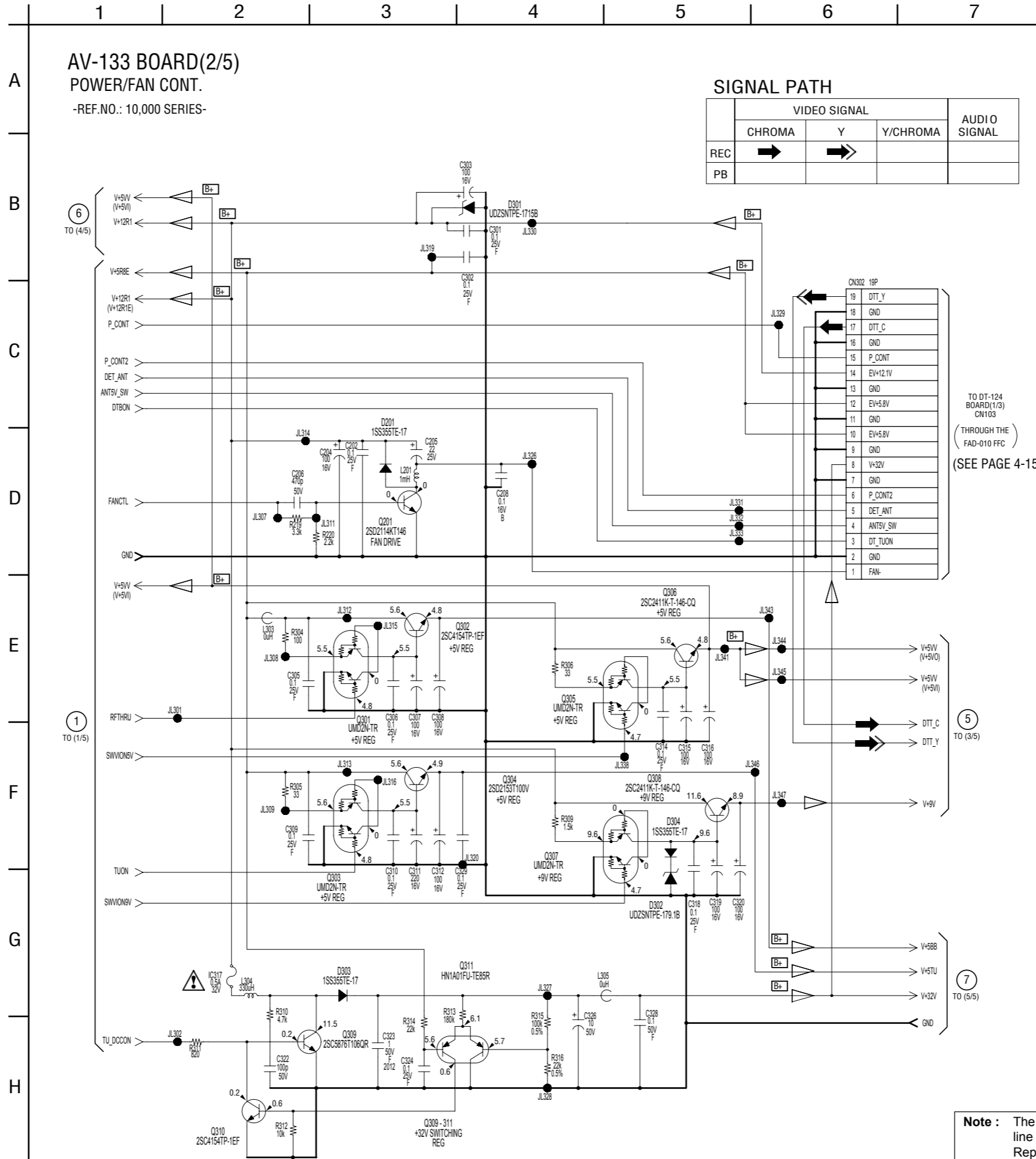

Note : The components identified by mark Δ or dotted line with mark Δ are critical for safety. Replace only with part number specified.

For Schematic Diagram
 • Refer to page 4-4 for waveforms.
 • Refer to page 4-43 for printed wiring board.

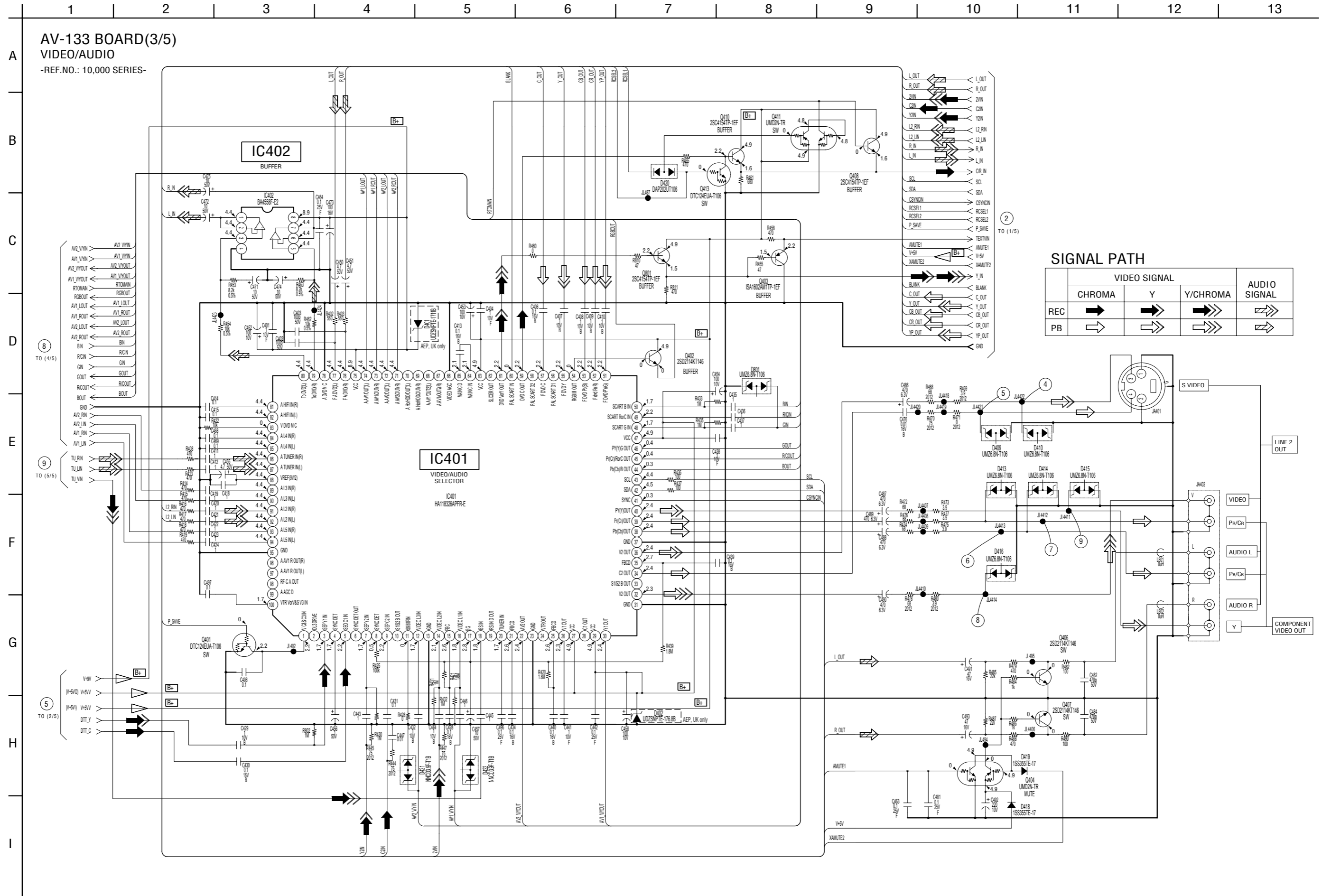

For Schematic Diagram

- Refer to page 4-4 for waveforms.
- Refer to page 4-43 for printed wiring board.

- Abbreviation
AUS : Australian model

1 2 3 4 5 6 7 8 9 10 11 12 13

A AV-133 BOARD(4/5)
EURO

-REF.NO.: 10,000 SERIES-

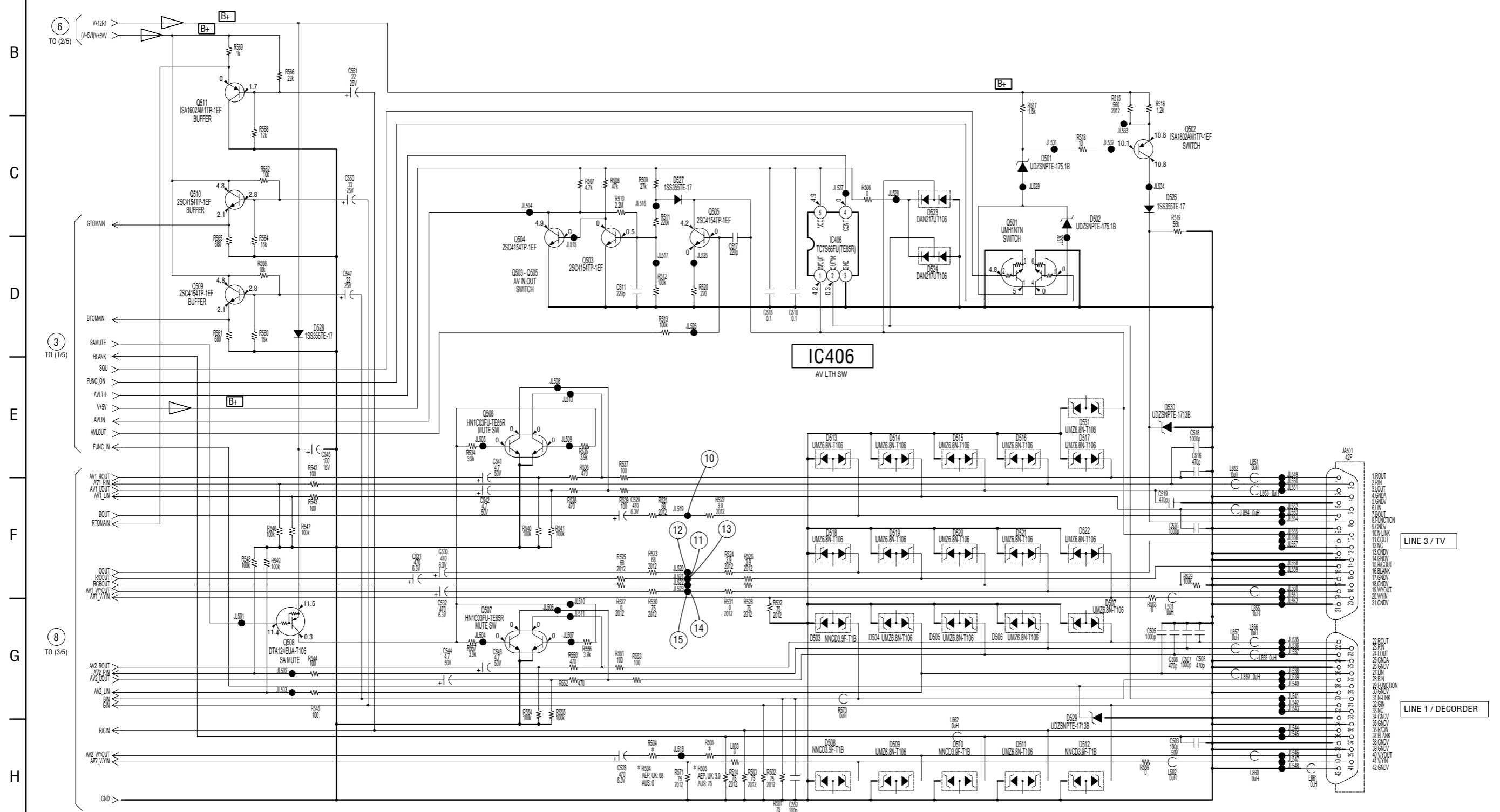

For Schematic Diagram

- Refer to page 4-4 for waveforms.
- Refer to page 4-43 for printed wiring board.

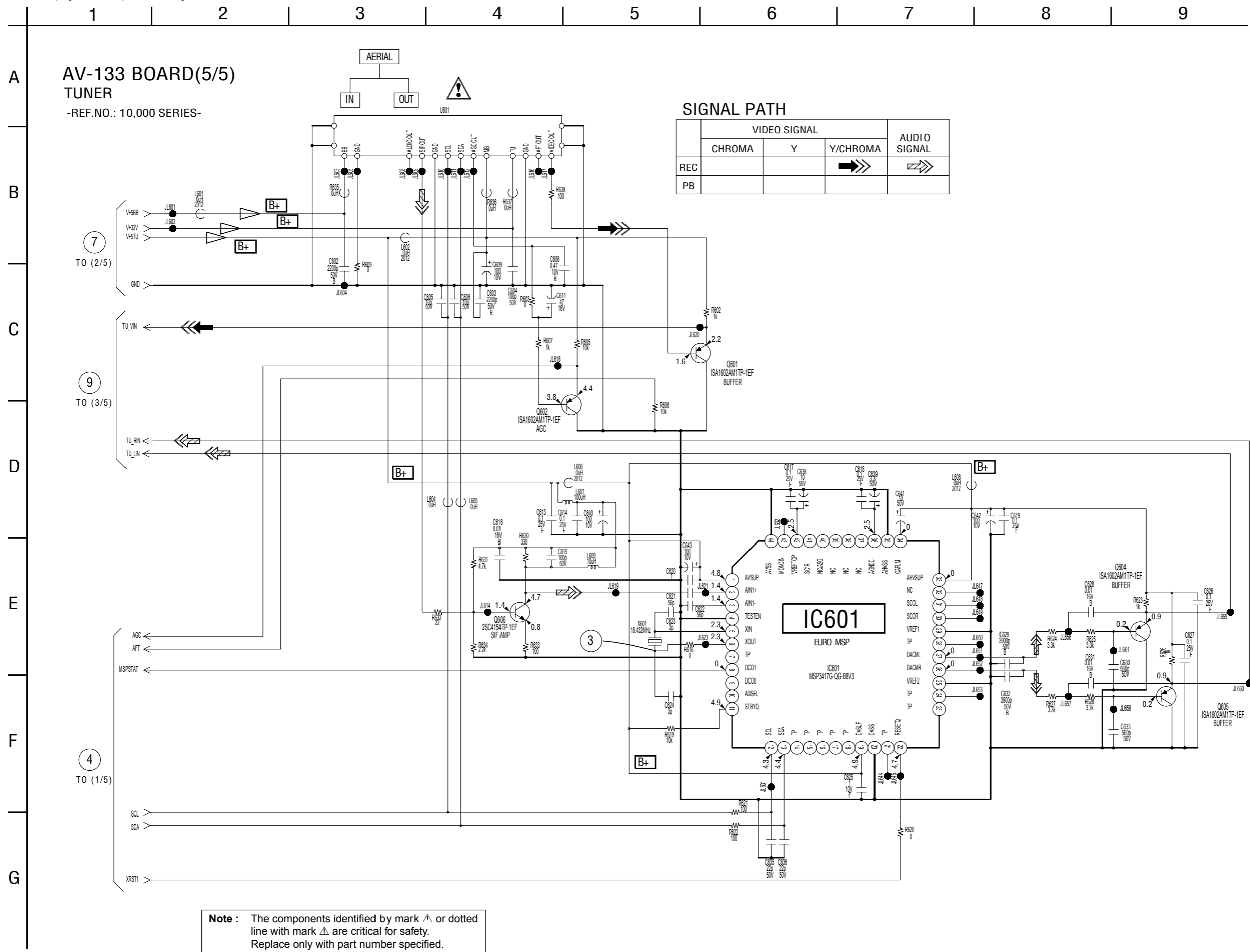

For Schematic Diagram
 • Refer to page 4-3 for waveforms.
 • Refer to page 4-47 for printed wiring board.

1 2 3 4 5 6 7 8 9 10 11 12 13 14

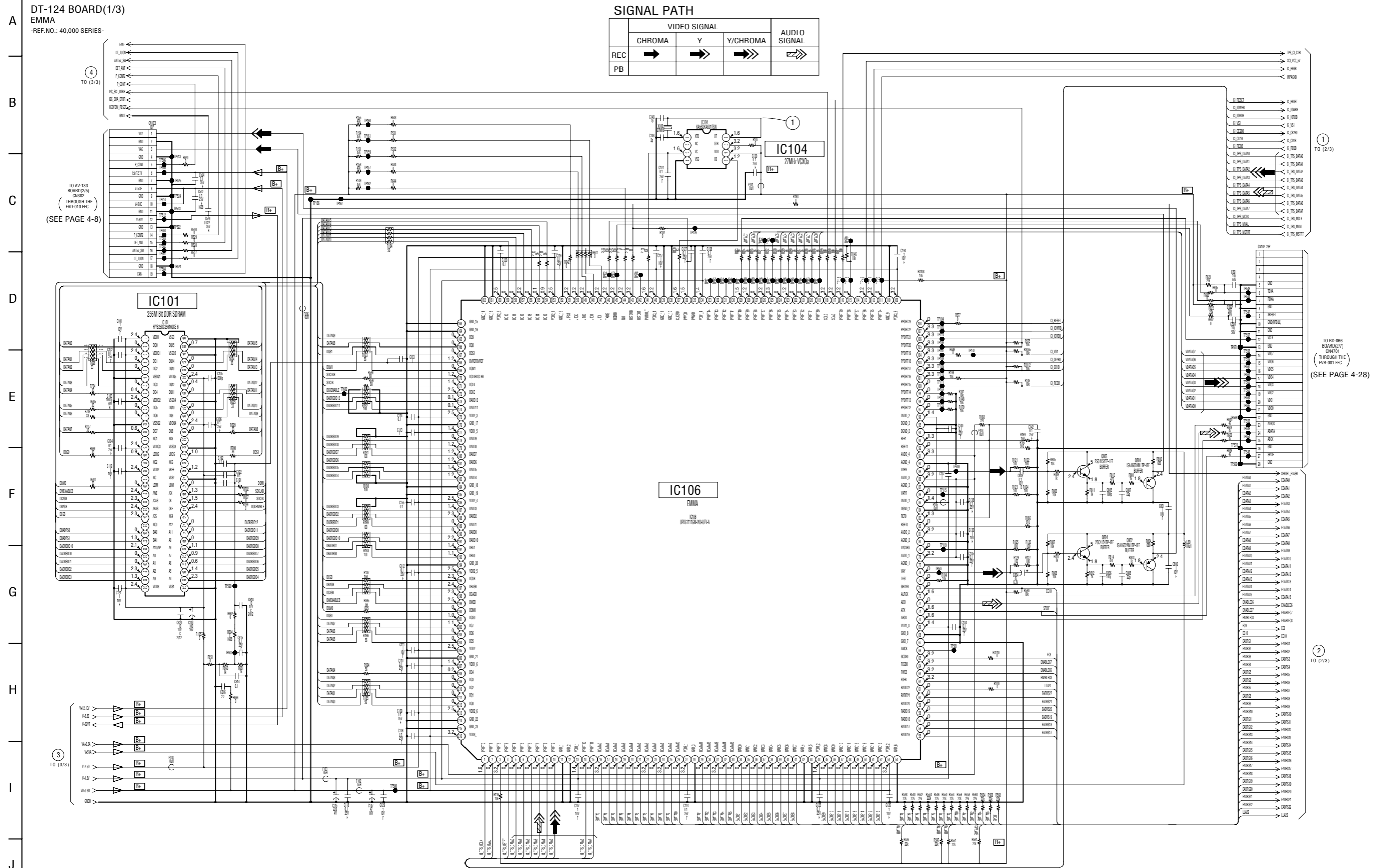

For Schematic Diagram
 • Refer to page 4-47 for printed wiring board.

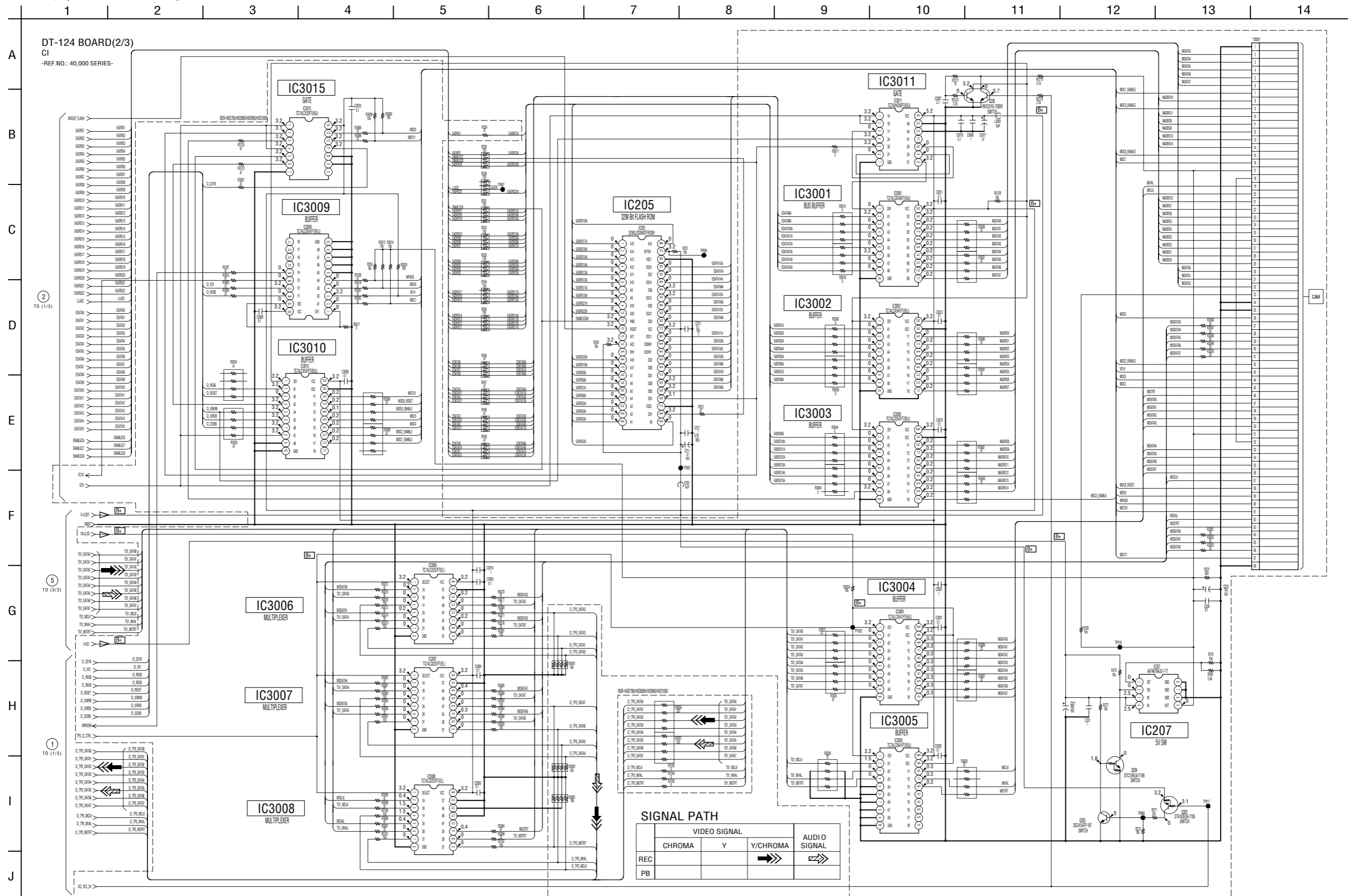

For Schematic Diagram
 • Refer to page 4-3 for waveforms.
 • Refer to page 4-47 for printed wiring board.

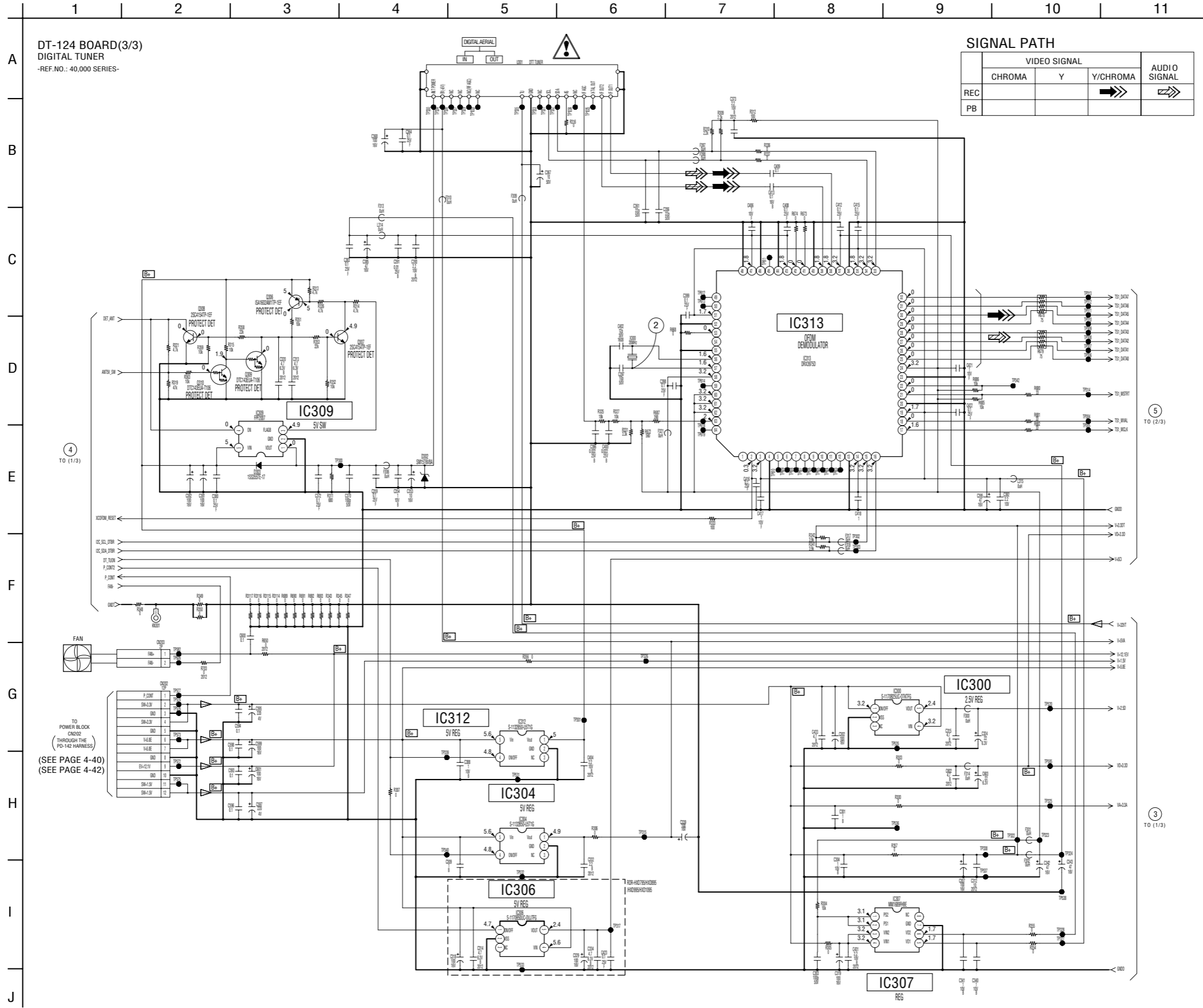

Note : The components identified by mark Δ or dotted line with mark Δ are critical for safety. Replace only with part number specified.

For Schematic Diagram

- Refer to page 4-3 for waveforms.
- Refer to page 4-41 for printed wiring board.

1 2 3 4 5 6 7 8 9 10

A
B
C
D
E
F
G
H

FR-291 BOARD
FL DRIVER, LINE 2 IN, FUNCTION SW
-REF.NO.: 30,000 SERIES-

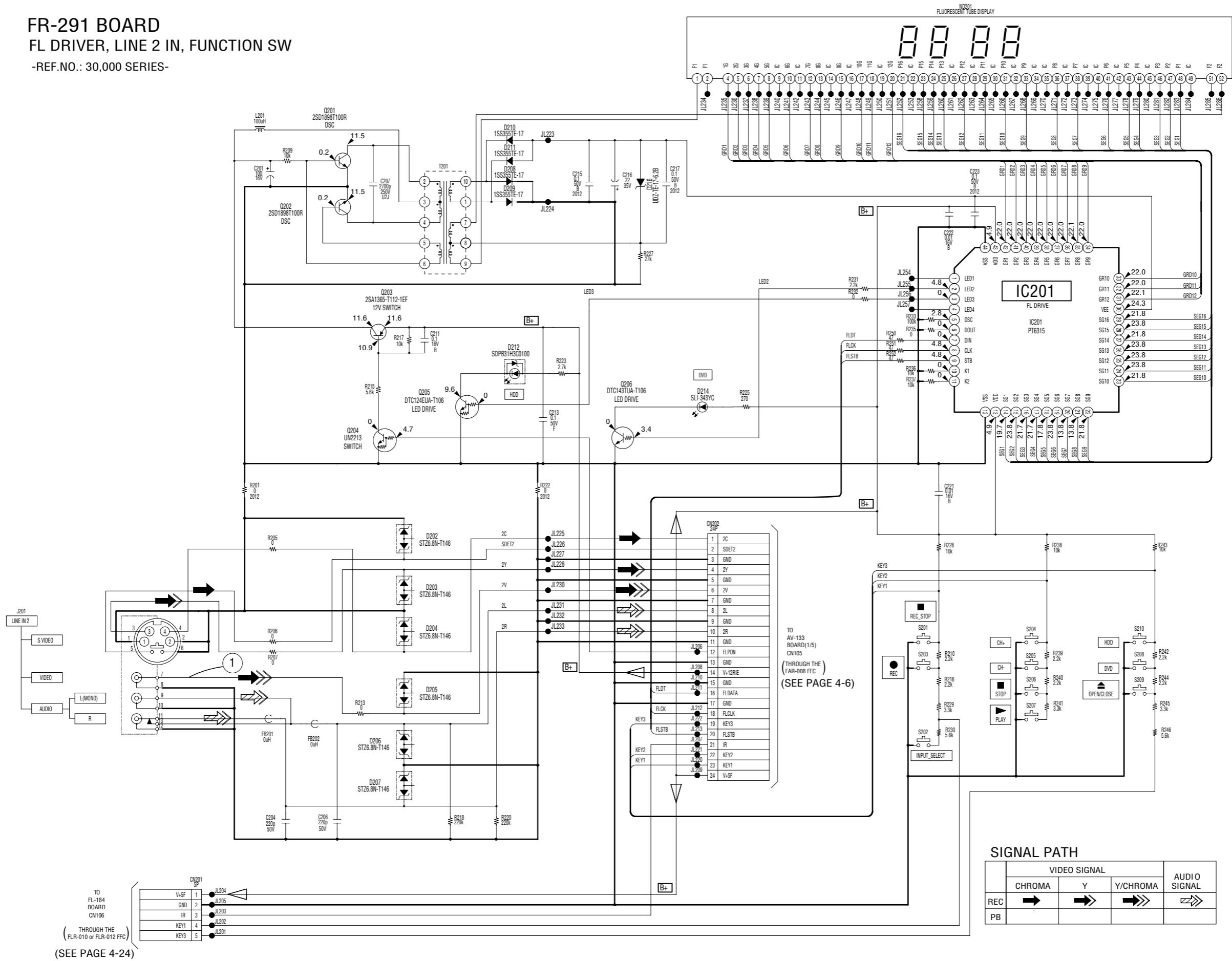

SIGNAL PATH

	VIDEO SIGNAL			AUDIO SIGNAL
	CHROMA	Y	Y/CHROMA	
REC	→	→	→	→
PB				→

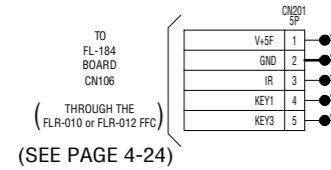

TO AV-133 BOARD(1/5) CN105 (THROUGH THE FAR-008 FFC) (SEE PAGE 4-6)

For Schematic Diagram
 • Refer to page 4-55 for printed wiring board.

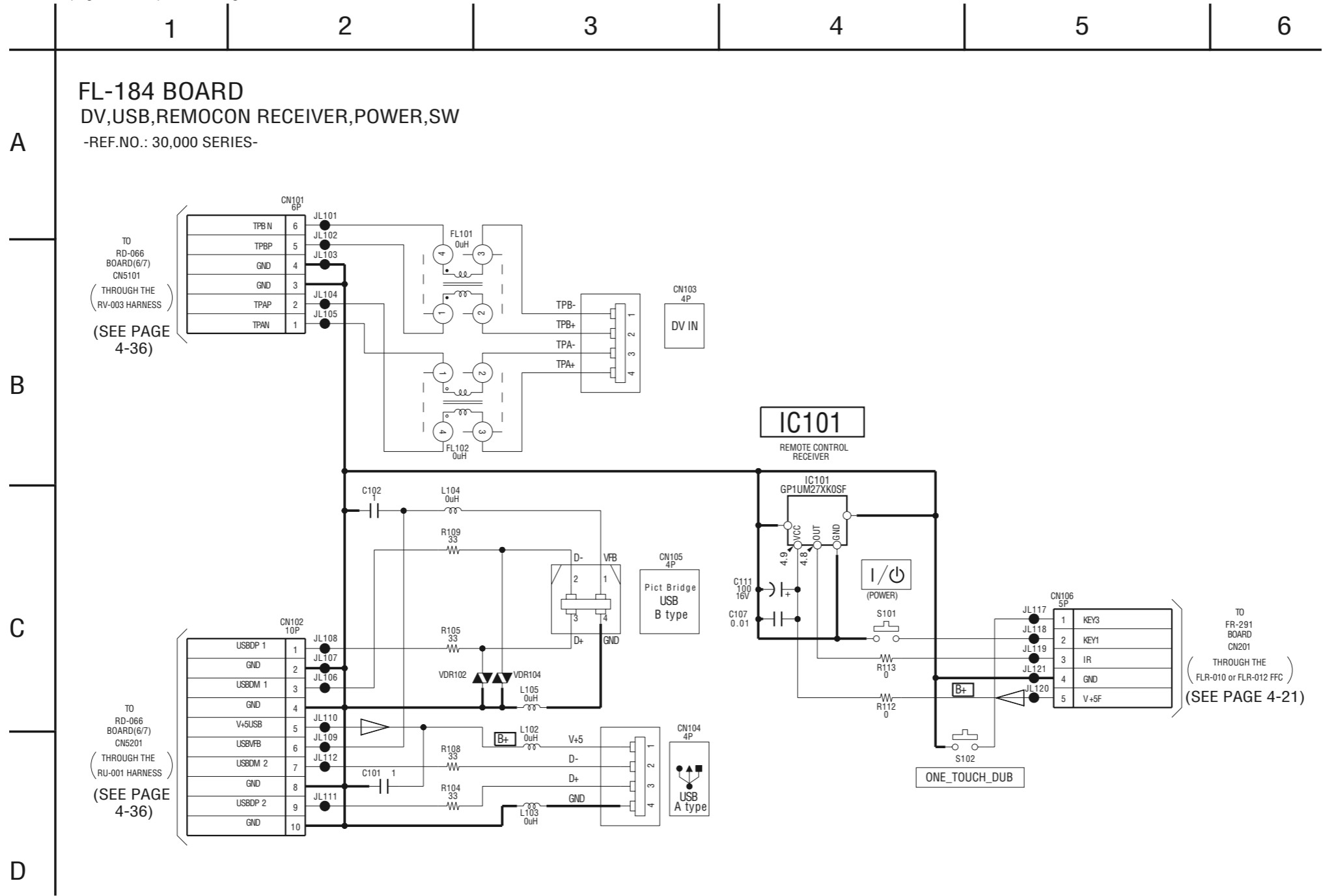

For Schematic Diagram

• Refer to page 4-51 for printed wiring board.

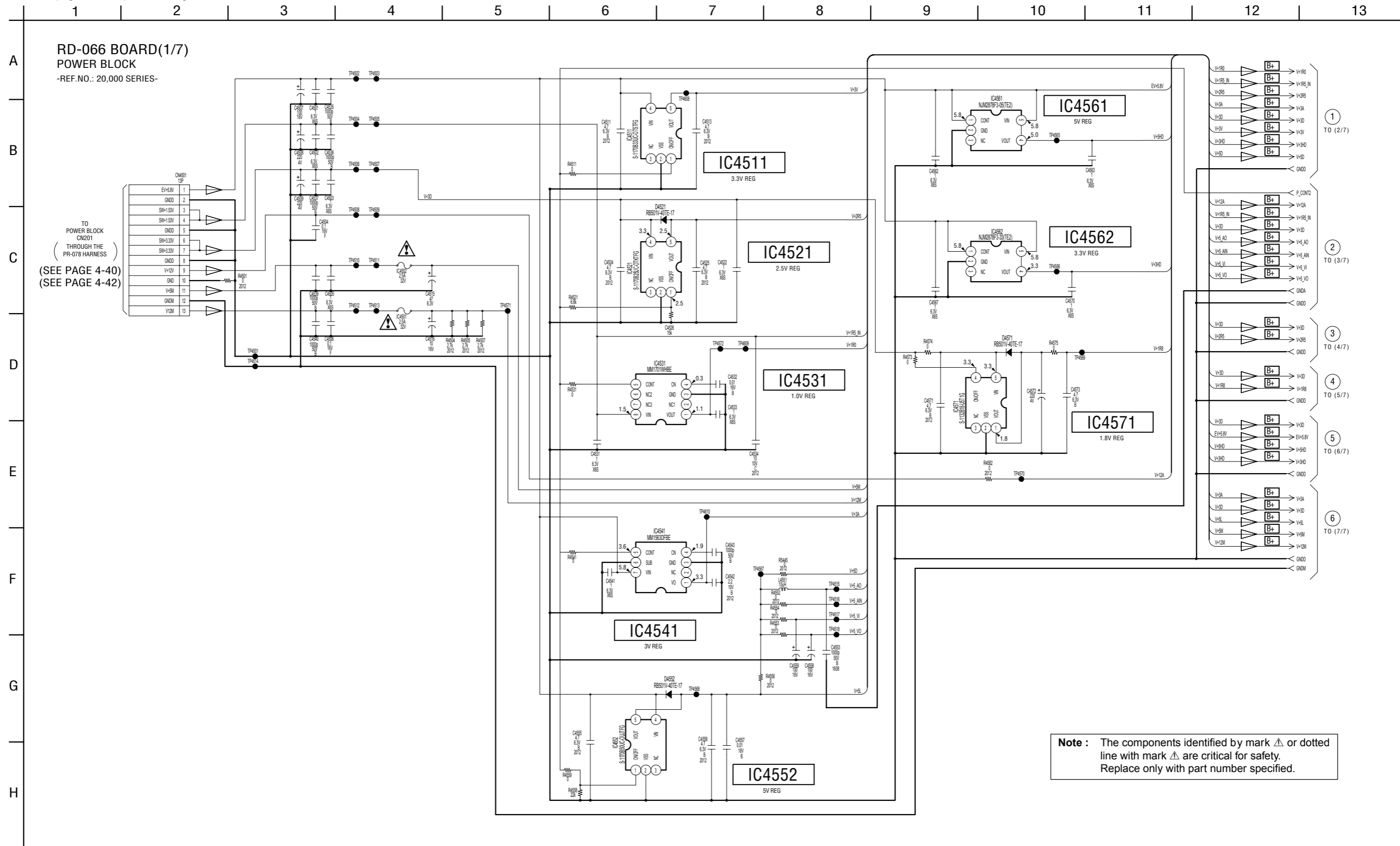

Note : The components identified by mark Δ or dotted line with mark Δ are critical for safety. Replace only with part number specified.

RDR-HXD790/HXD795/HXD890/HXD895/HXD990/HXD995/HXD1090/HXD1095

- For Schematic Diagram**
- Refer to page 4-3 for waveforms.
 - Refer to page 4-51 for printed wiring board.

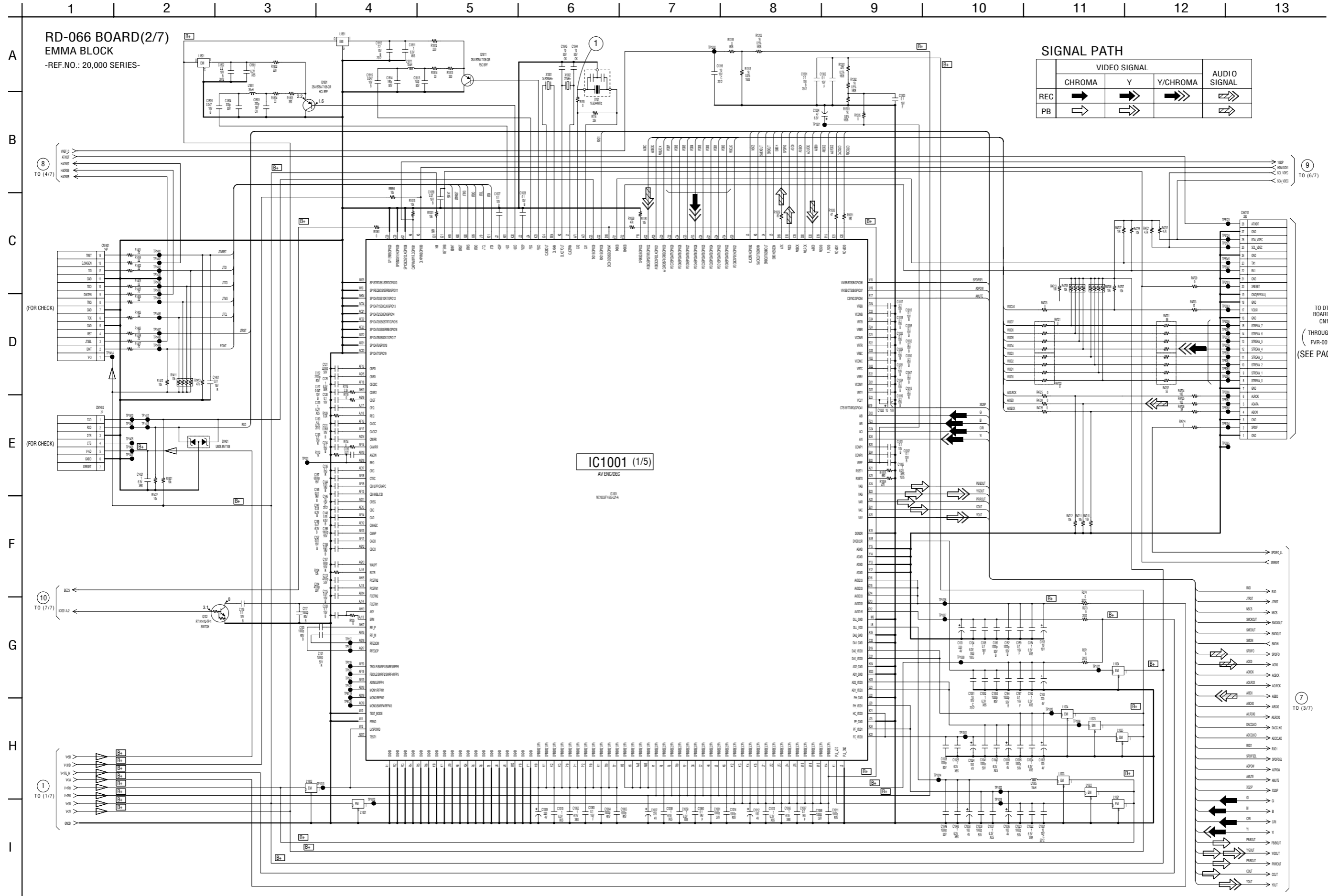

SIGNAL PATH

	VIDEO SIGNAL			AUDIO SIGNAL
	CHROMA	Y	Y/CHROMA	
REC	→	→	→	→
PB	⇨	⇨	⇨	⇨

IC1001 (1/5)
AV ENCODEC

TO DT-124 BOARD(1/3) CN102
(THROUGH THE FVR-001 FFC)
(SEE PAGE 4-16)

TO (3/7)

TO (6/7)

TO (4/7)

TO (7/7)

TO (1/7)

For Schematic Diagram
 • Refer to page 4-51 for printed wiring board.

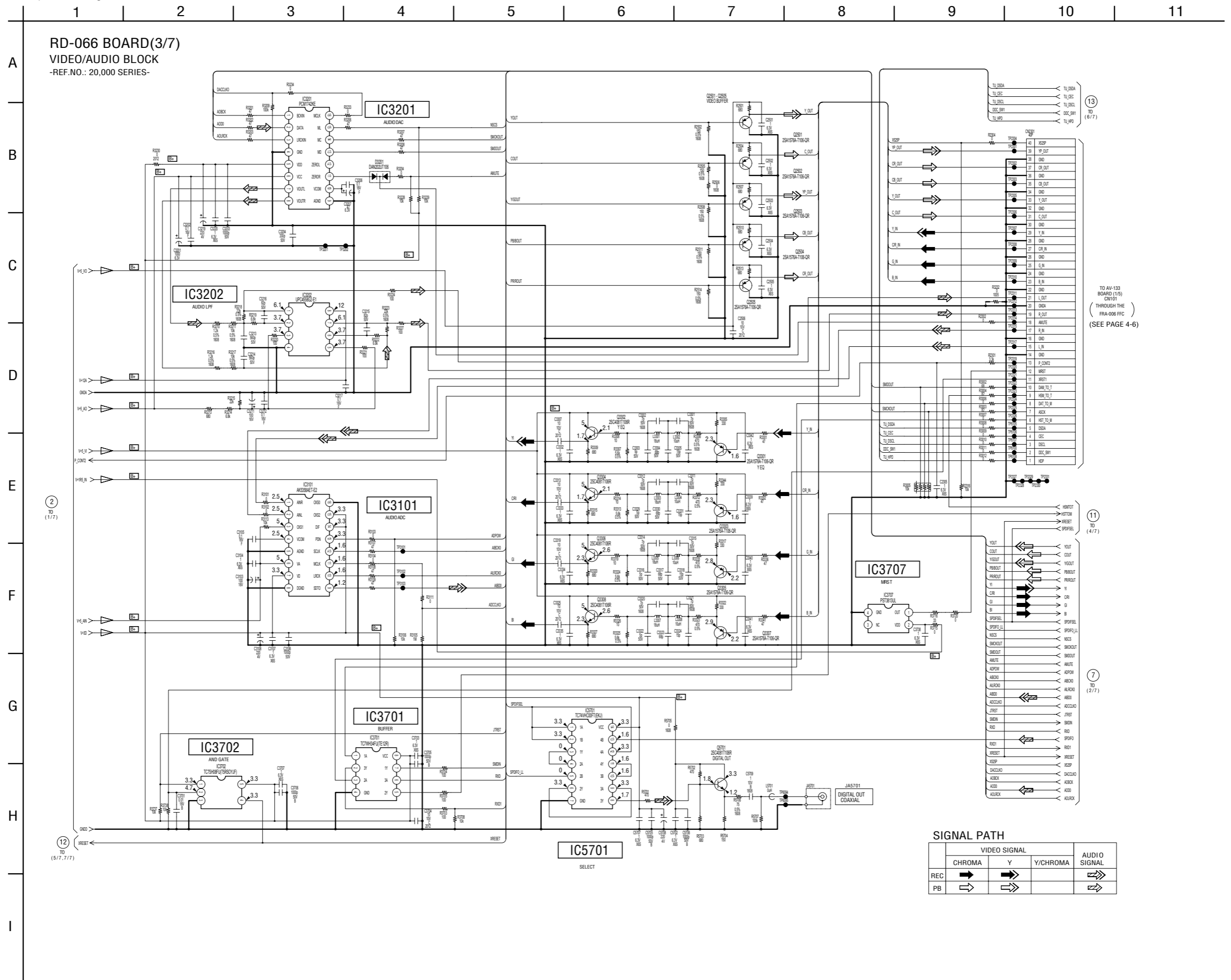

SIGNAL PATH

	VIDEO SIGNAL			AUDIO SIGNAL
	CHROMA	Y	Y/CHROMA	
REC	→	→	→	→
PB	→	→	→	→

For Schematic Diagram
• Refer to page 4-51 for printed wiring board.

1 2 3 4 5 6 7 8 9 10

A
B
C
D
E
F
G
H

RD-066 BOARD(4/7)
MEMORY BLOCK
-REF.NO.: 20,000 SERIES-

IC1001 (2/5)
AVENDEC

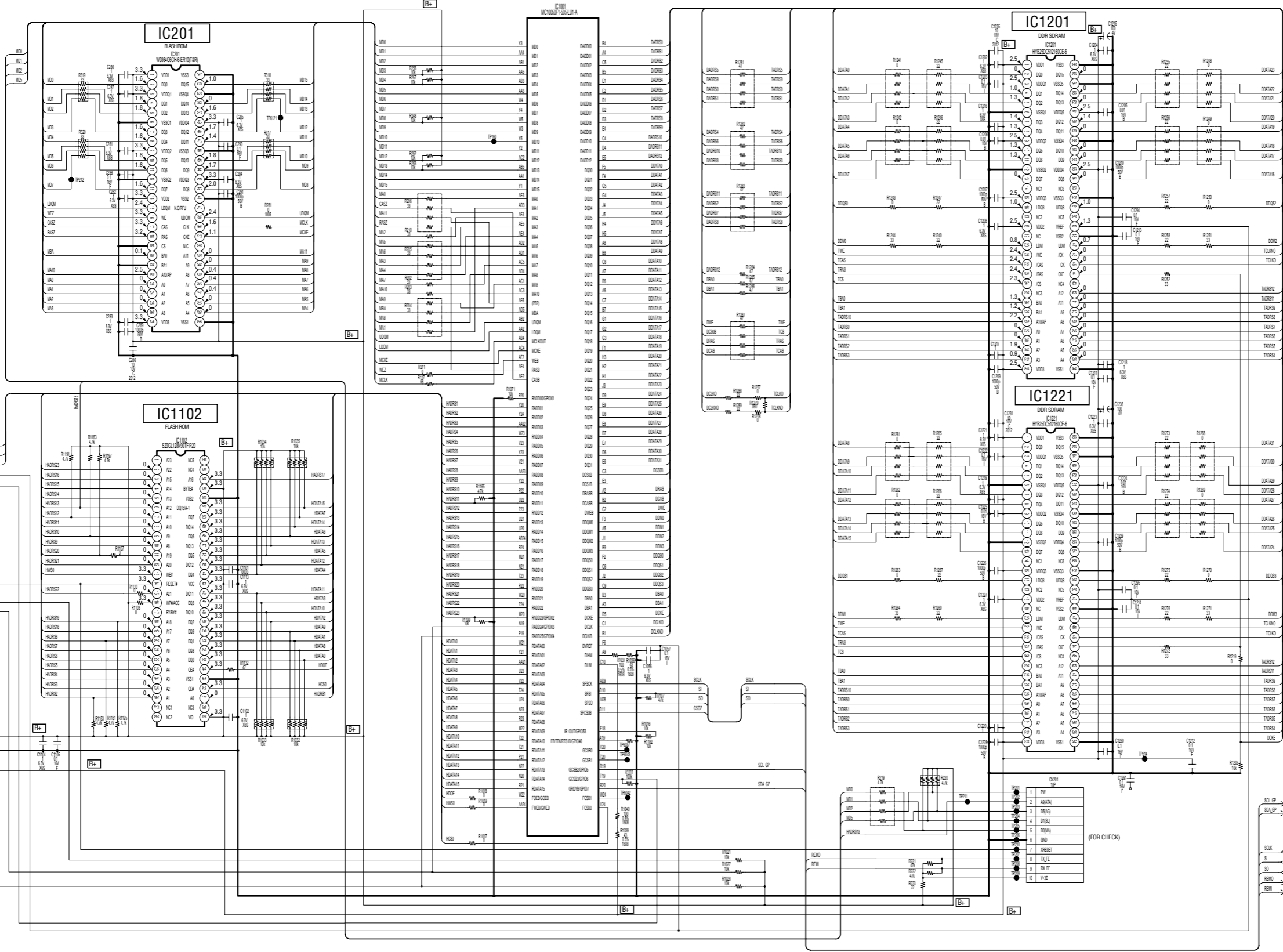

8 TO (2/7)

11 TO (3/7)

3 TO (1/7)

15 TO (6/7)

16 TO (7/7)

For Schematic Diagram

- Refer to page 4-3 for waveforms.
- Refer to page 4-51 for printed wiring board.

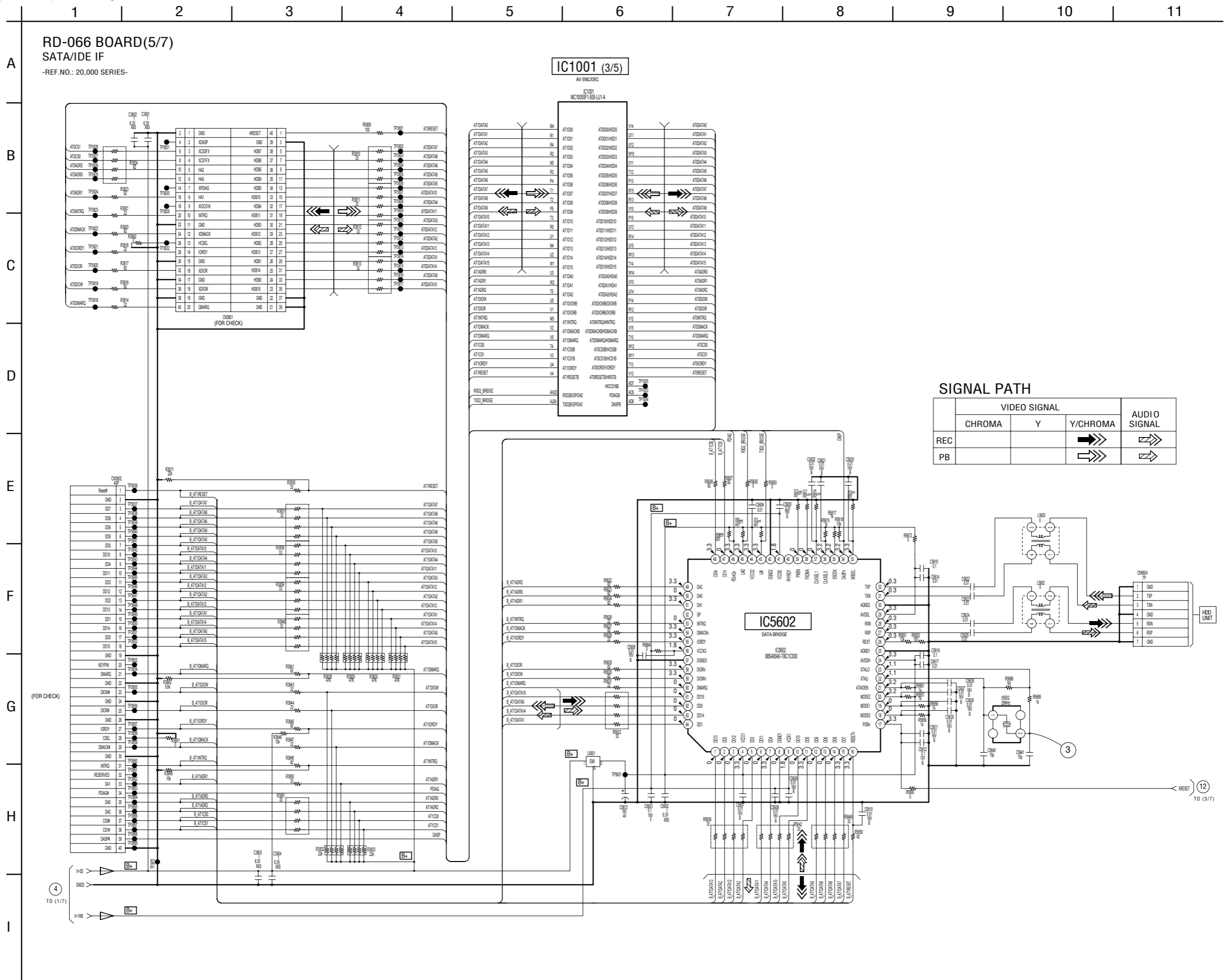

RDR-HXD790/HXD795/HXD890/HXD895/HXD990/HXD995/HXD1090/HXD1095

For Schematic Diagram
 • Refer to page 4-3 for waveforms.
 • Refer to page 4-51 for printed wiring board.

1 2 3 4 5 6 7 8 9 10 11 12 13 14

A

RD-066 BOARD(6/7) HDMI/DV/USB BLOCK -REF.NO.: 20,000 SERIES-

B

C

D

E

F

G

H

I

Note: The HDMI block is highly confidential, and prohibited from releasing to public.
 The components identified by mark (B) contain confidential information.
 Strictly follow the instructions whenever the components are repaired and/or replaced.

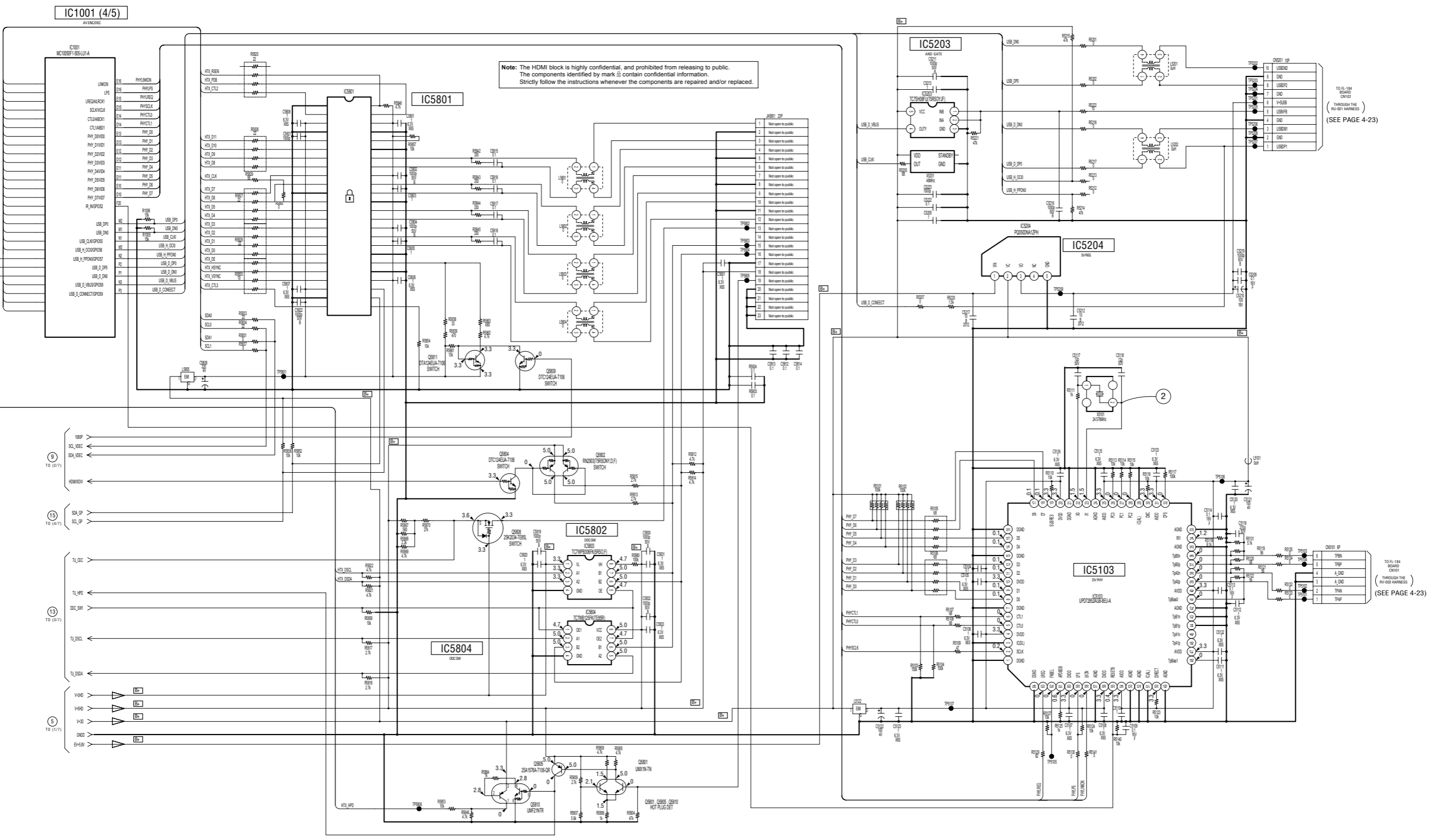

TO PL-184 BOARD CN102 (THROUGH THE HV-003 HARNESS) (SEE PAGE 4-23)

TO PL-184 BOARD CN101 (THROUGH THE HV-003 HARNESS) (SEE PAGE 4-23)

For Schematic Diagram
 • Refer to page 4-51 for printed wiring board.

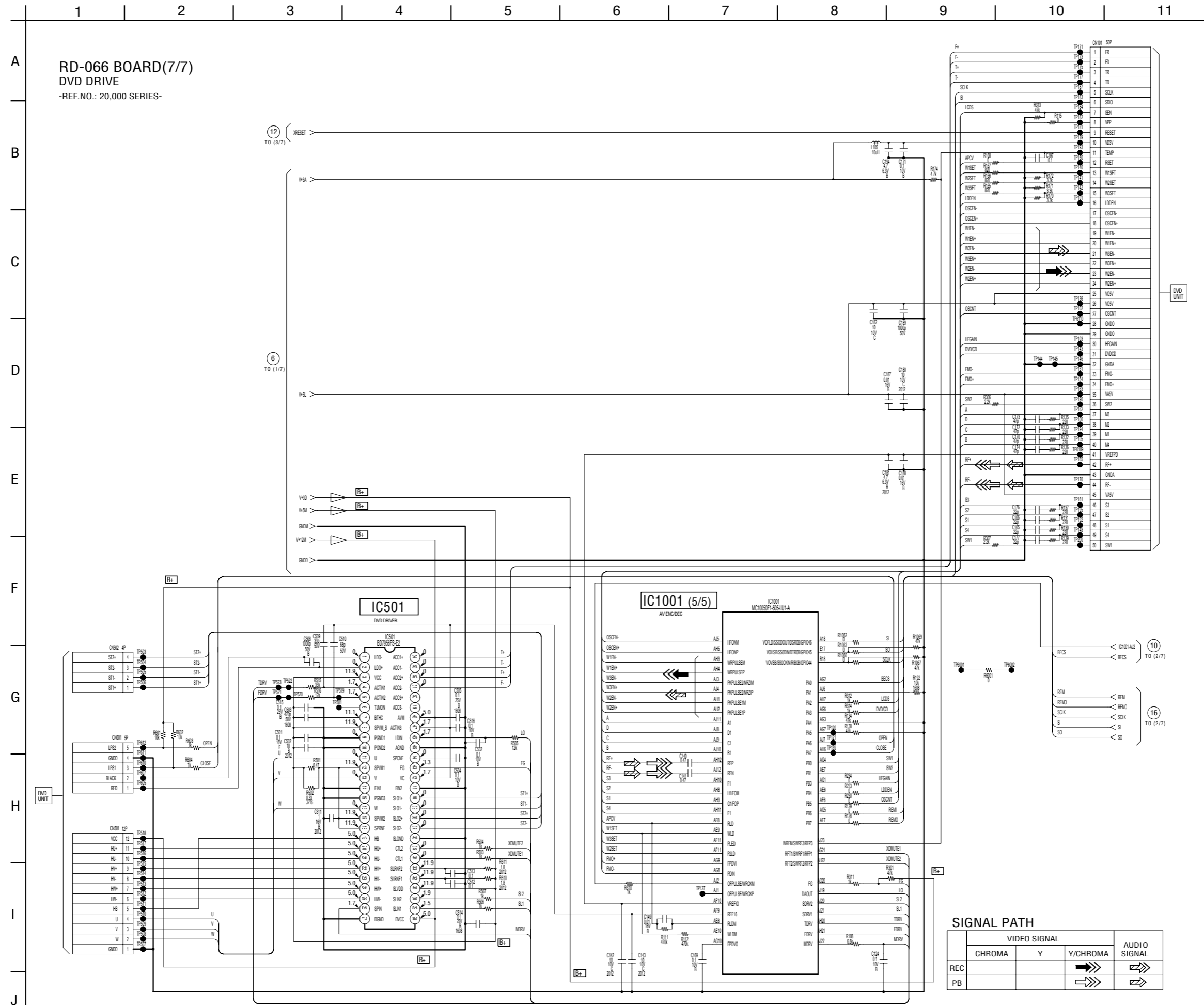

RD-066 BOARD(7/7)
DVD DRIVE
 -REF.NO.: 20,000 SERIES-

Pin	Signal
1	FR
2	FD
3	TR
4	TD
5	SCLK
6	SDIO
7	SEN
8	VPP
9	RESET
10	VDIV
11	TEMP
12	RSET
13	WYSET
14	WQSET
15	WQSET
16	LDEN
17	OSEN+
18	OSEN+
19	WYEN+
20	WYEN+
21	WQEN+
22	WQEN+
23	WQEN+
24	WQEN+
25	VOSV
26	VOSV
27	OSDIT
28	GND0
29	GND0
30	HFGAIN
31	DVDCD
32	GND4
33	FMD-
34	FMD+
35	VASV
36	SW2
37	MS
38	M2
39	M1
40	M4
41	VREFD
42	RF+
43	GND4
44	RF-
45	VASV
46	S3
47	S2
48	S1
49	S4
50	SW1

SIGNAL PATH

	VIDEO SIGNAL			AUDIO SIGNAL
	CHROMA	Y	Y/CHROMA	
REC			→	→
PB			→	→

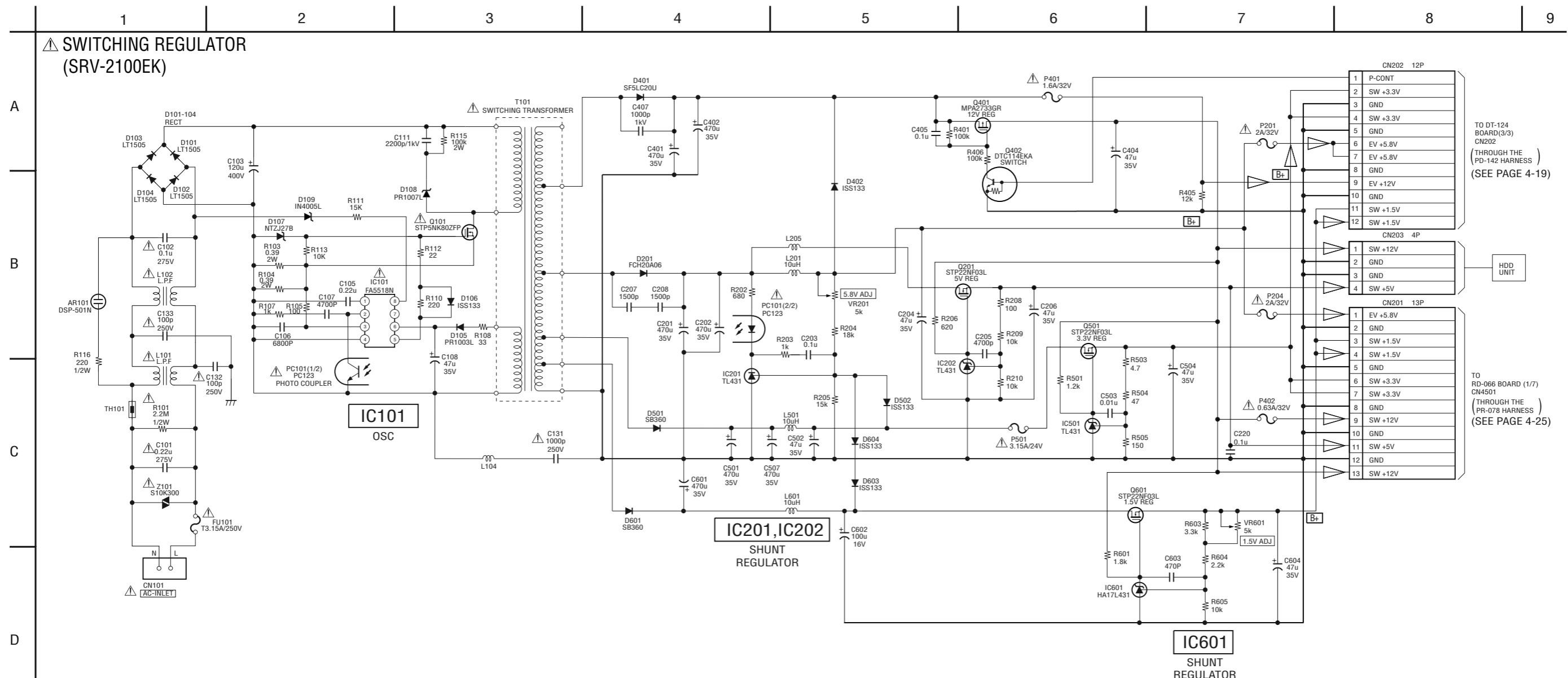

TO DT-124 BOARD(3/3)
CN202
(THROUGH THE PD-142 HARNESS)
(SEE PAGE 4-19)

HDD UNIT

TO RD-066 BOARD (1/7)
CN4501
(THROUGH THE PR-078 HARNESS)
(SEE PAGE 4-25)

Note : The components identified by mark Δ or dotted line with mark Δ are critical for safety. Replace only with part number specified.

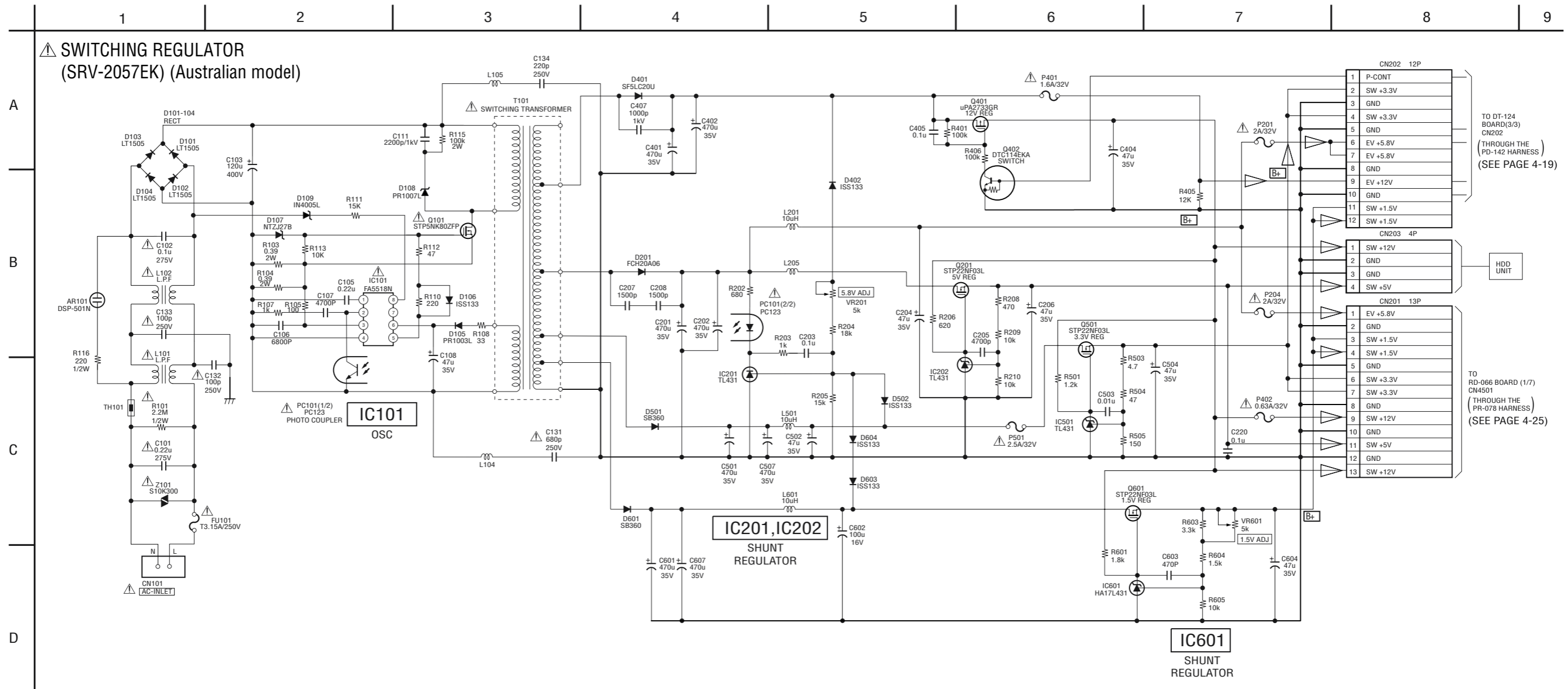

Note : The components identified by mark \triangle or dotted line with mark \triangle are critical for safety. Replace only with part number specified.

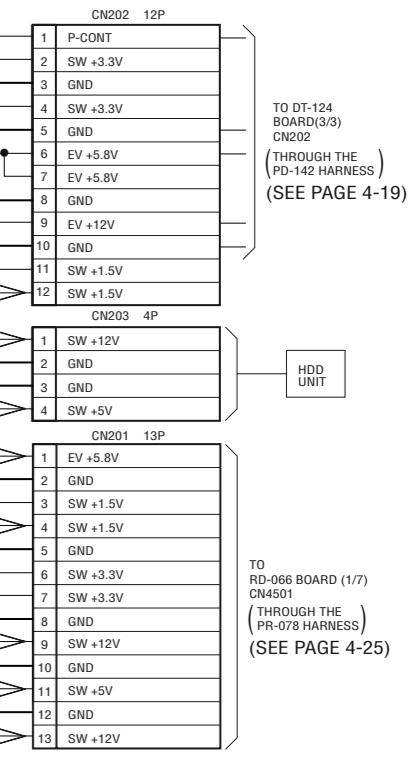

4-3. PRINTED WIRING BOARDS

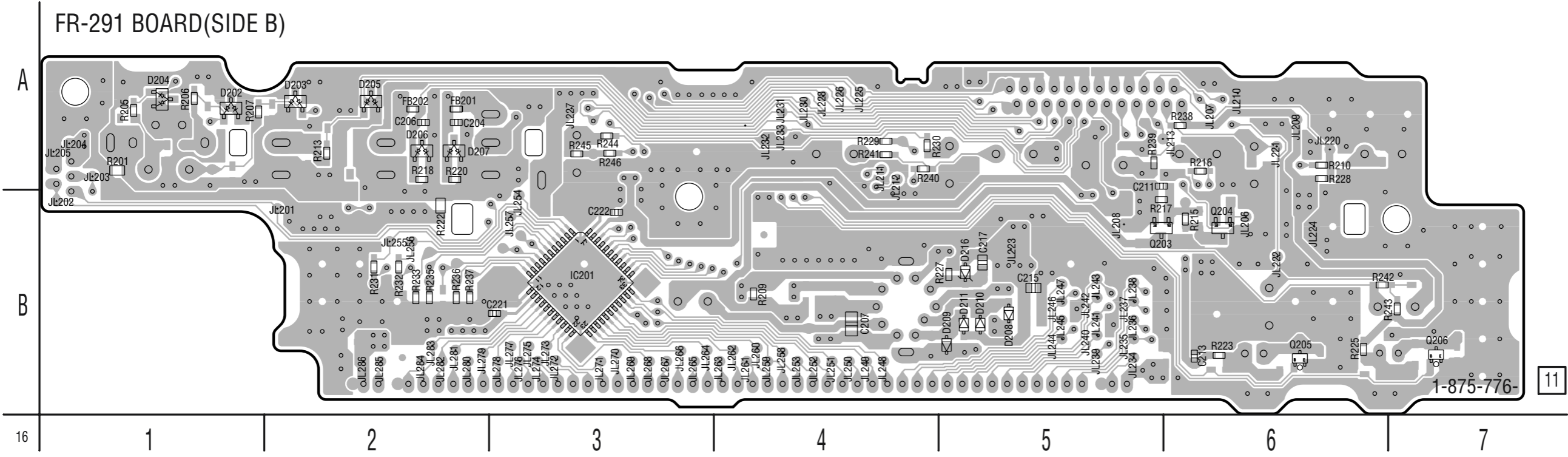
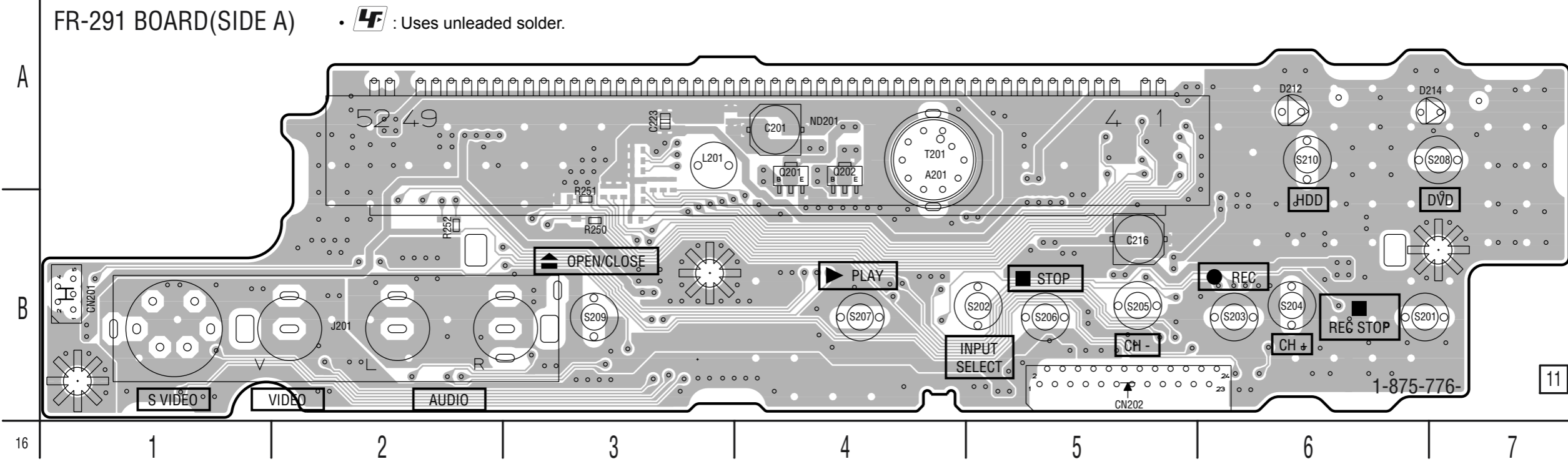

FR-291BOARD (SIDE A)

CN201	B-1	Q201	B-4
CN202	B-5	Q202	B-4
D212	A-6		
D214	A-7		

FR-291 BOARD (SIDE B)

D202	A-1	D211	B-5
D203	A-2	D216	B-5
D204	A-1		
D205	A-2	IC201	B-3
D206	A-2		
D207	A-2	Q203	B-5
D208	B-5	Q204	B-6
D209	B-5	Q205	B-6
D210	B-5	Q206	B-7

AV-133 BOARD(SIDE A)

•  : Uses unleaded solder.

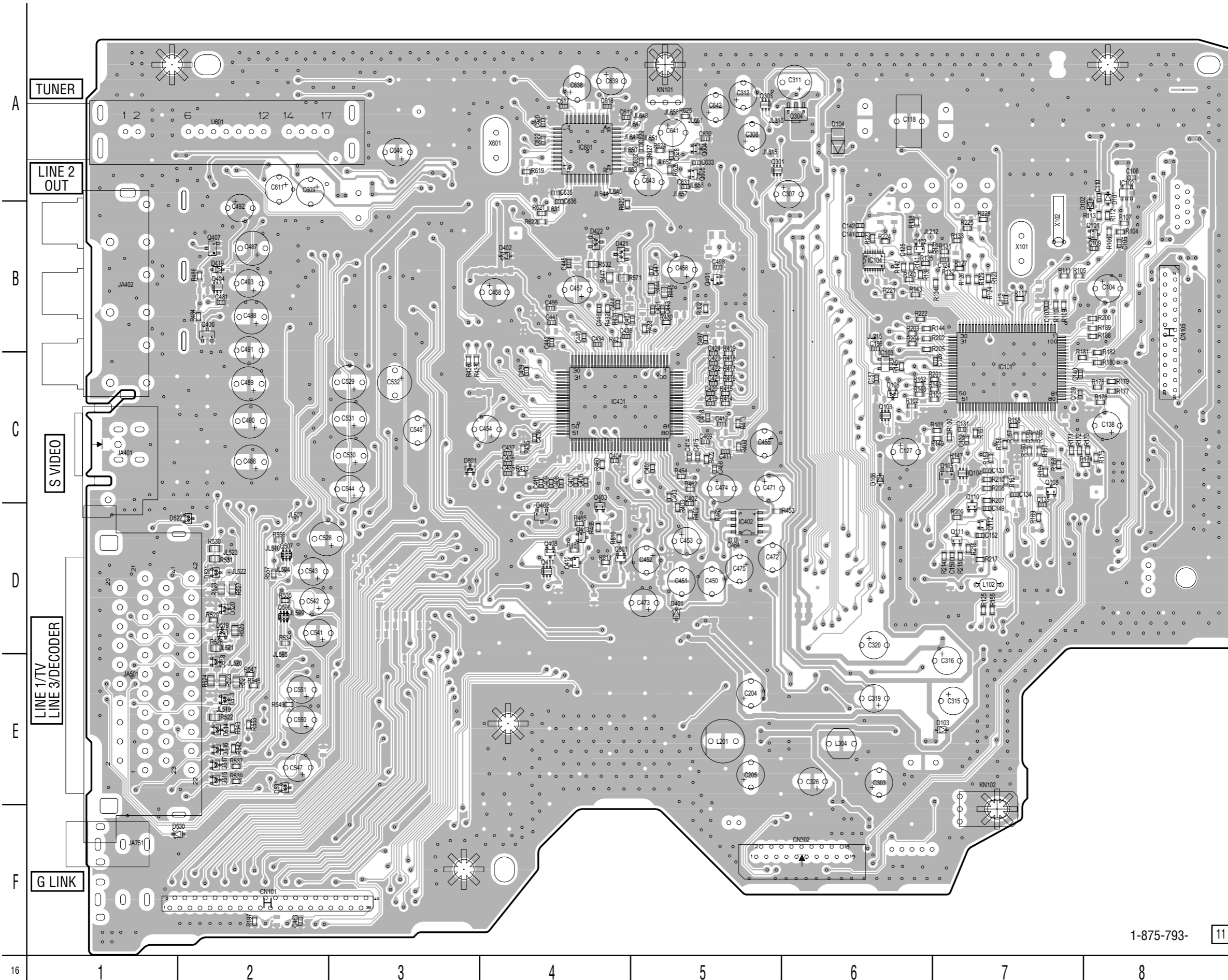

AV-133 BOARD (SIDE A)

- | | |
|-------|-----|
| CN101 | F-2 |
| CN105 | B-8 |
| CN302 | F-6 |
| | |
| D101 | B-8 |
| D102 | B-8 |
| D103 | E-7 |
| D104 | A-6 |
| D106 | C-6 |
| D108 | C-6 |
| D401 | D-5 |
| D402 | B-4 |
| D419 | B-2 |
| D421 | B-4 |
| D422 | B-4 |
| D513 | E-2 |
| D514 | E-2 |
| D515 | E-2 |
| D516 | E-2 |
| D517 | E-2 |
| D518 | E-2 |
| D519 | D-2 |
| D520 | D-2 |
| D521 | D-2 |
| D522 | D-2 |
| D530 | F-2 |
| D531 | E-2 |
| D801 | C-3 |
| | |
| IC101 | C-7 |
| IC102 | A-1 |
| IC103 | C-6 |
| IC104 | B-6 |
| IC401 | C-5 |
| IC402 | D-5 |
| IC601 | A-4 |
| | |
| Q101 | B-8 |
| Q102 | B-6 |
| Q103 | C-6 |
| Q104 | C-7 |
| Q105 | C-7 |
| Q108 | C-7 |
| Q110 | D-7 |
| Q111 | D-7 |
| Q112 | D-7 |
| Q301 | A-5 |
| Q303 | A-5 |
| Q304 | A-6 |
| Q401 | B-5 |
| Q402 | D-4 |
| Q403 | D-4 |
| Q404 | B-2 |
| Q406 | B-2 |
| Q407 | B-2 |
| Q408 | D-4 |
| Q410 | D-4 |
| Q411 | D-4 |
| Q413 | D-4 |
| Q506 | D-2 |
| Q507 | D-2 |
| Q604 | A-5 |
| Q605 | A-5 |
| Q801 | D-5 |

1-875-793-

11

16 1 2 3 4 5 6 7 8

AV-133 BOARD(SIDE B) •  : Uses unleaded solder.

AV-133 BOARD (SIDE B)

- D201 E-4
- D301 F-3
- D302 E-3
- D303 E-3
- D304 E-3
- D409 C-8
- D410 C-7
- D413 B-8
- D414 B-8
- D415 B-8
- D416 C-8
- D418 B-7
- D420 D-5
- D501 D-6
- D502 D-6
- D503 E-7
- D504 E-7
- D505 E-7
- D506 E-7
- D507 E-7
- D508 D-7
- D509 D-7
- D510 D-7
- D511 D-7
- D512 E-7
- D523 E-6
- D524 F-7
- D526 D-6
- D527 E-6
- D528 C-6
- D529 E-7
- IC150 C-1
- IC317 E-3
- IC406 E-6
- Q201 E-4
- Q302 A-3
- Q305 E-3
- Q306 E-2
- Q307 E-3
- Q308 E-3
- Q309 E-3
- Q310 E-3
- Q311 E-3
- Q501 D-6
- Q502 D-6
- Q503 E-6
- Q504 E-6
- Q505 E-6
- Q508 C-6
- Q509 E-7
- Q510 E-6
- Q511 E-6
- Q601 A-6
- Q602 A-7
- Q606 A-6
- Q751 F-7
- Q752 F-7

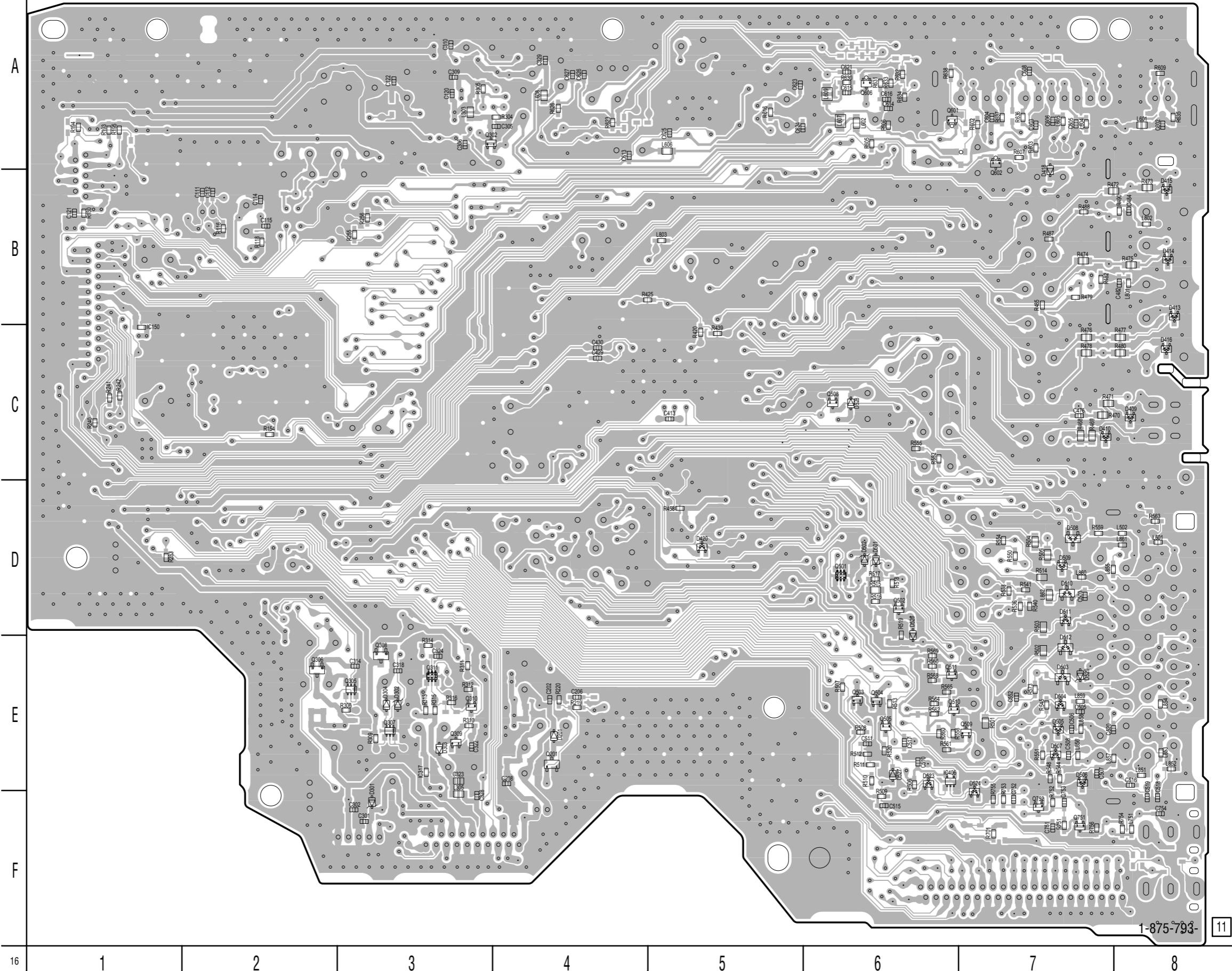

DT-124 BOARD(SIDE A)

•  : Uses unleaded solder.

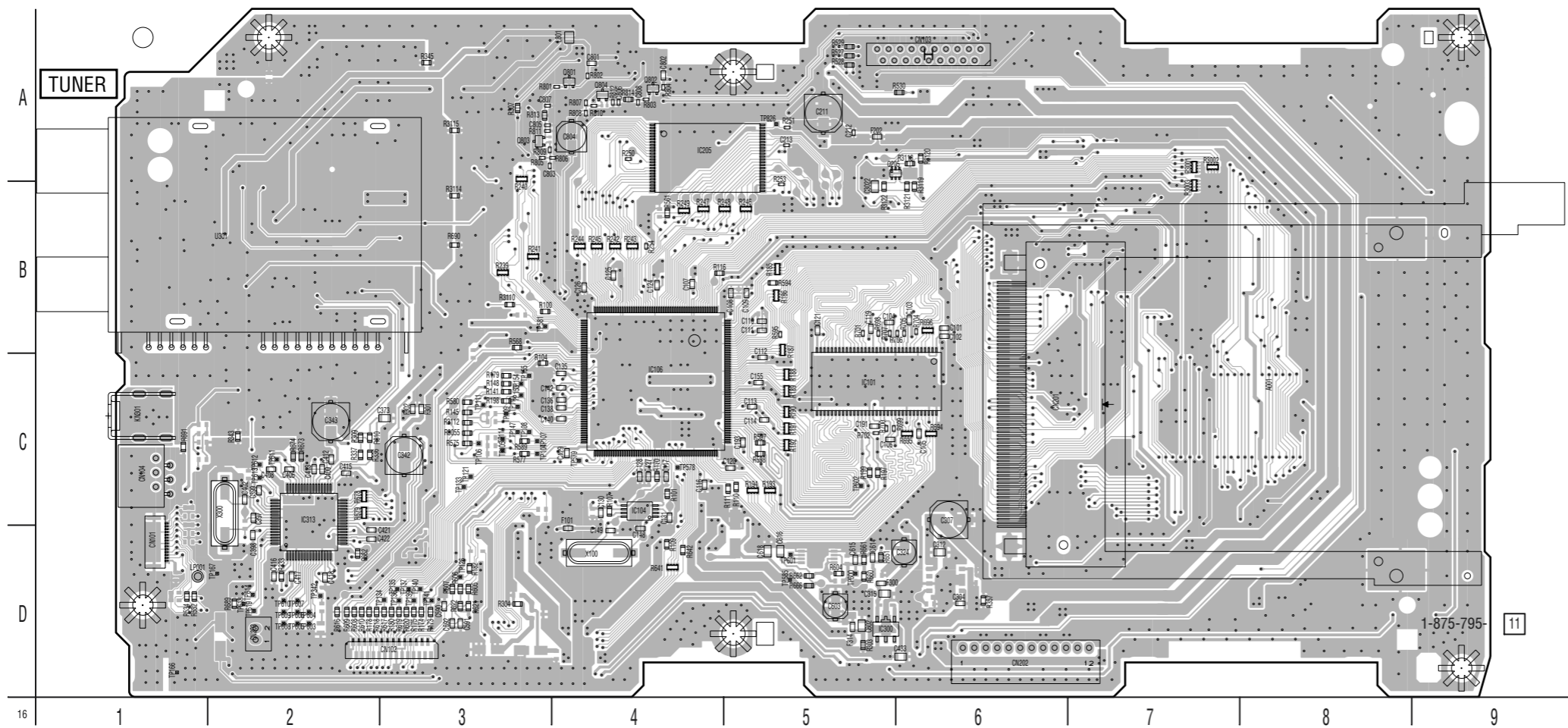

DT-124 BOARD (SIDE A)

CN102	D-3
CN103	A-6
CN201	C-6
CN202	D-6
CN203	D-2
IC101	C-5
IC104	C-4
IC106	C-4
IC205	A-4
IC300	D-5
IC313	C-2
Q205	A-6
Q801	A-4
Q802	A-4
Q803	A-3
Q804	A-4

DT-124 BOARD(SIDE B)

•  : Uses unleaded solder.

DT-124 BOARD (SIDE B)

- | | |
|--------|-----|
| D302 | B-9 |
| D303 | B-8 |
| IC207 | B-4 |
| IC304 | A-6 |
| IC306 | D-2 |
| IC307 | D-7 |
| IC309 | B-8 |
| IC312 | A-7 |
| IC3001 | B-4 |
| IC3002 | A-4 |
| IC3003 | A-4 |
| IC3004 | C-3 |
| IC3005 | C-3 |
| IC3006 | C-2 |
| IC3007 | C-2 |
| IC3008 | C-3 |
| IC3009 | B-2 |
| IC3010 | B-3 |
| IC3011 | B-3 |
| IC3015 | B-3 |
| Q202 | A-4 |
| Q203 | A-4 |
| Q204 | A-4 |
| Q306 | B-7 |
| Q307 | B-7 |
| Q308 | B-7 |
| Q309 | B-7 |
| Q310 | B-7 |

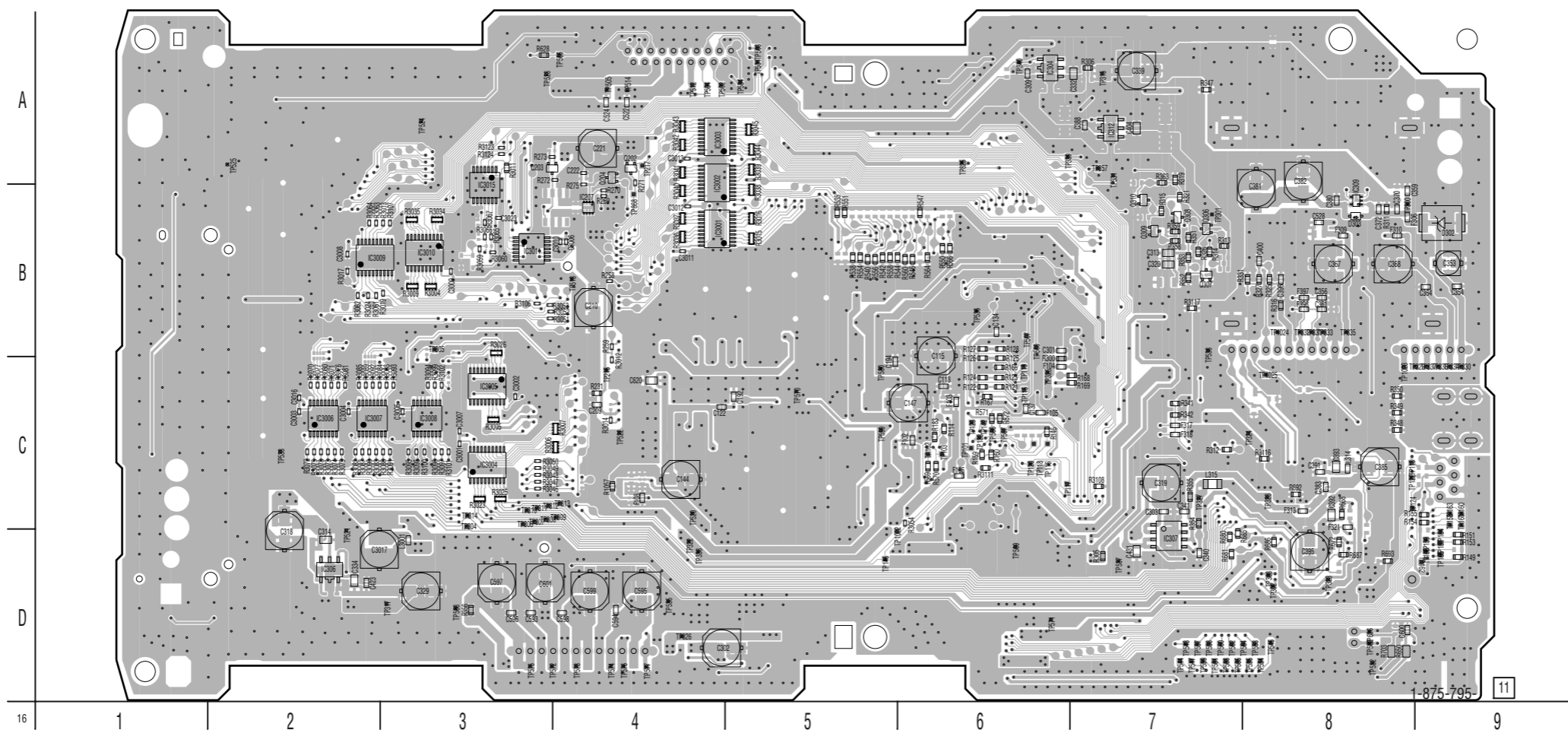

RD-066 BOARD(SIDE A)

•  : Uses unleaded solder.

RD-066 BOARD (SIDE A)

- CN1401 E-5
- CN1402 F-4
- CN201 E-5
- CN2301 E-1
- CN3802 D-1
- CN4501 D-5
- CN4701 E-5
- CN5604 F-2

- D1401 F-4
- D3201 E-2
- D4521 E-5
- D4552 B-4

- IC1001 D-3
- IC1221 E-4
- IC3201 E-2
- IC3202 E-1
- IC3701 D-1
- IC3707 B-5
- IC4502 C-5
- IC4511 D-2
- IC4521 E-5
- IC4552 B-4
- IC4562 F-3
- IC5203 D-4
- IC5204 C-4
- IC5602 F-2
- IC5801 E-3
- IC5803 F-3
- IC5804 F-3

- Q1811 D-2
- Q2501 E-2
- Q2502 E-2
- Q2503 D-2
- Q2504 E-2
- Q2505 E-2
- Q3301 E-1
- Q3302 E-2
- Q3303 E-1
- Q3304 E-2
- Q5805 F-3
- Q5809 F-3
- Q5810 E-2
- Q5811 F-3

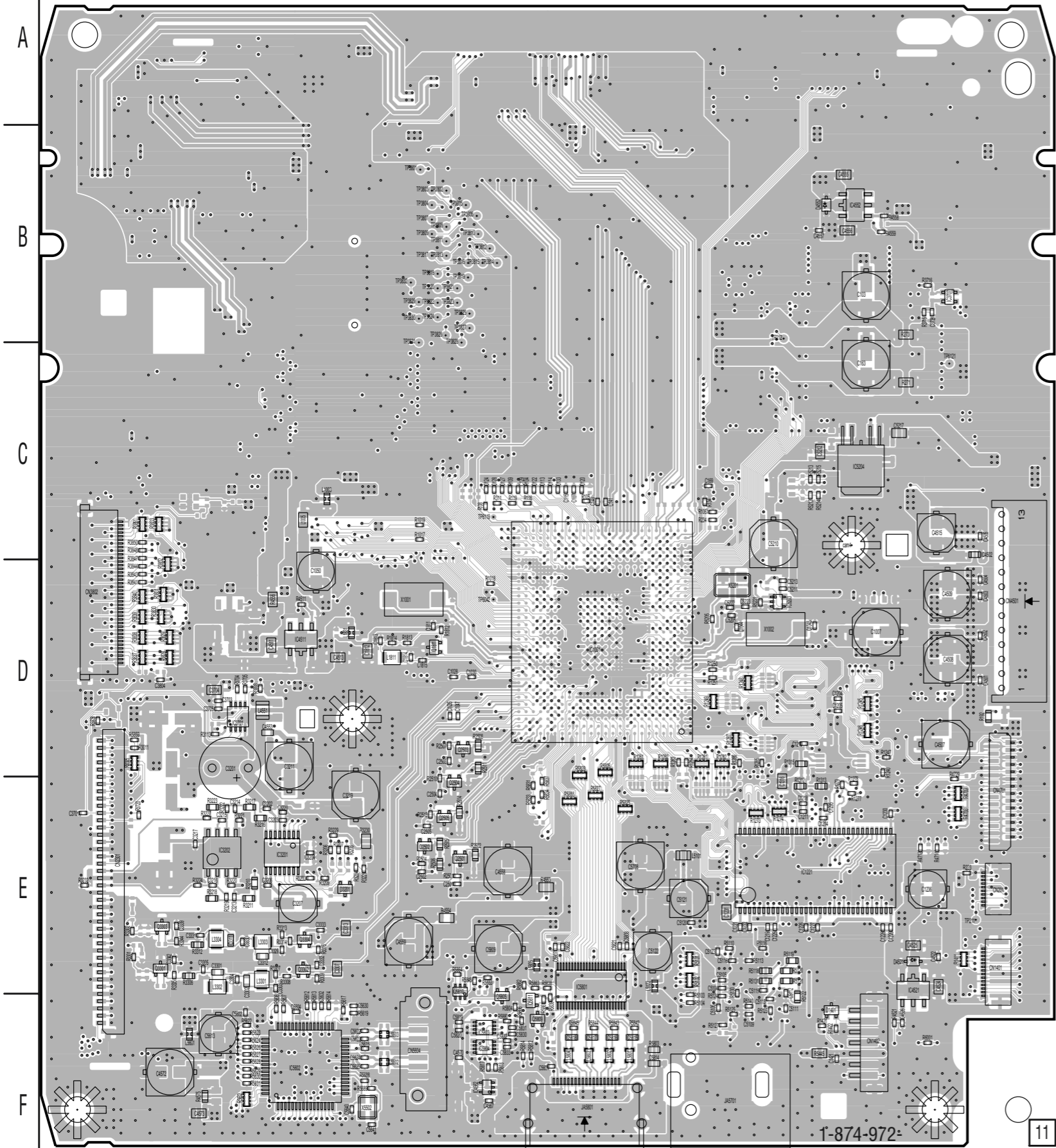

16 1 2 3 4 5

RD-066 BOARD(SIDE B) •  : Uses unleaded solder.

RD-066 BOARD (SIDE B)

- CN101 A-3
- CN501 A-4
- CN502 B-4
- CN5101 E-1
- CN5201 D-2
- CN601 A-5

- D4571 F-4

- IC1102 C-4
- IC1201 D-1
- IC201 B-1
- IC3101 D-4
- IC3702 D-5
- IC4501 C-1
- IC4531 B-1
- IC4541 B-1
- IC4561 F-3
- IC4571 F-4
- IC501 B-5
- IC5103 E-2
- IC5701 E-3

- Q102 C-3
- Q1801 D-3
- Q3305 E-5
- Q3306 E-4
- Q3307 E-5
- Q3308 E-4
- Q5701 E-2
- Q5801 F-3
- Q5802 F-3
- Q5804 E-3
- Q5808 F-3

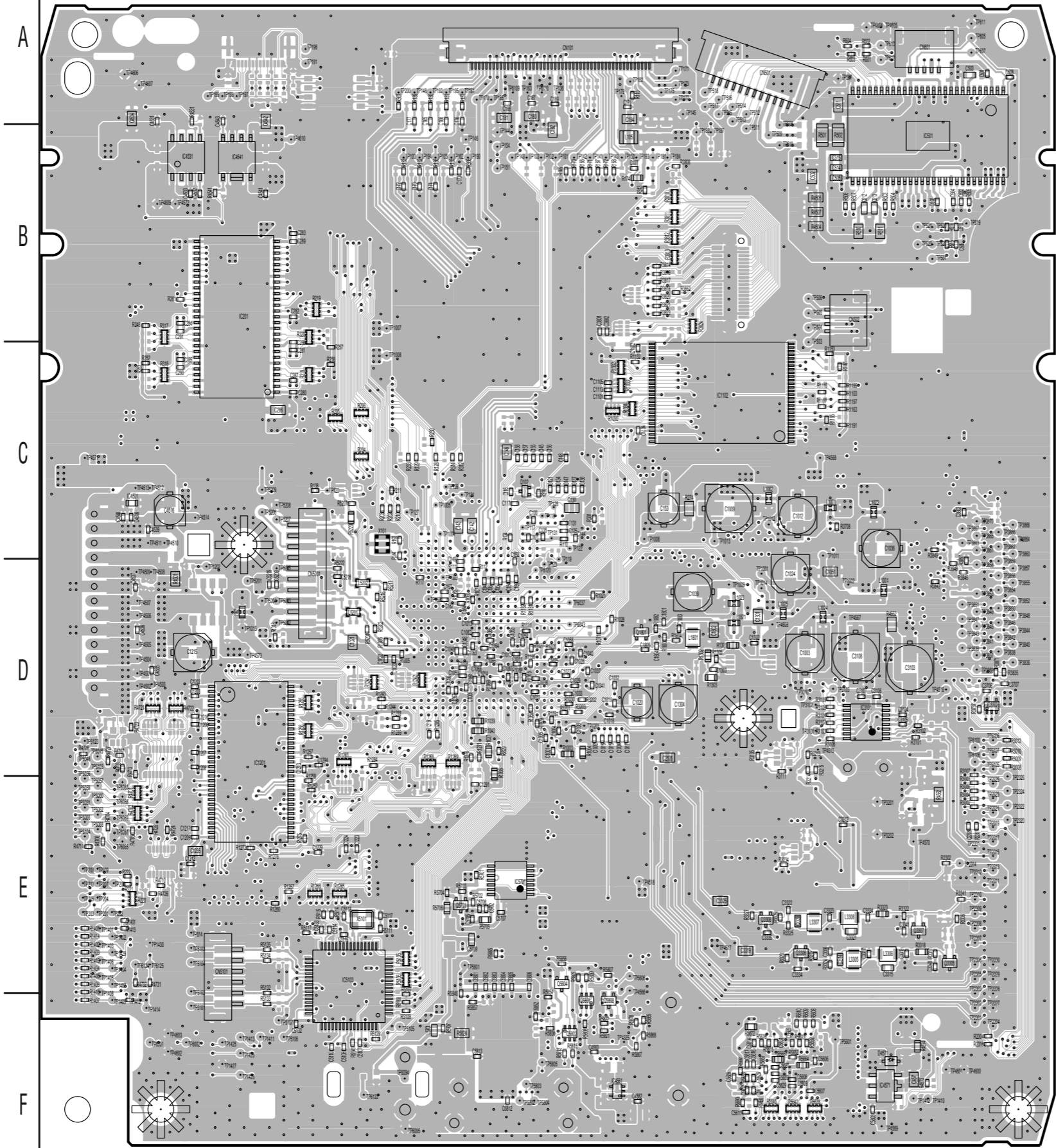

1-874-972- 11

16 1 2 3 4 5

FL-184 BOARD(SIDE A) •  : Uses unleaded solder.

FL-184 BOARD (SIDE A)

- CN101 B-3
- CN102 B-3
- CN103 B-3
- CN104 B-2
- CN105 B-1
- CN106 B-4

- IC101 A-2

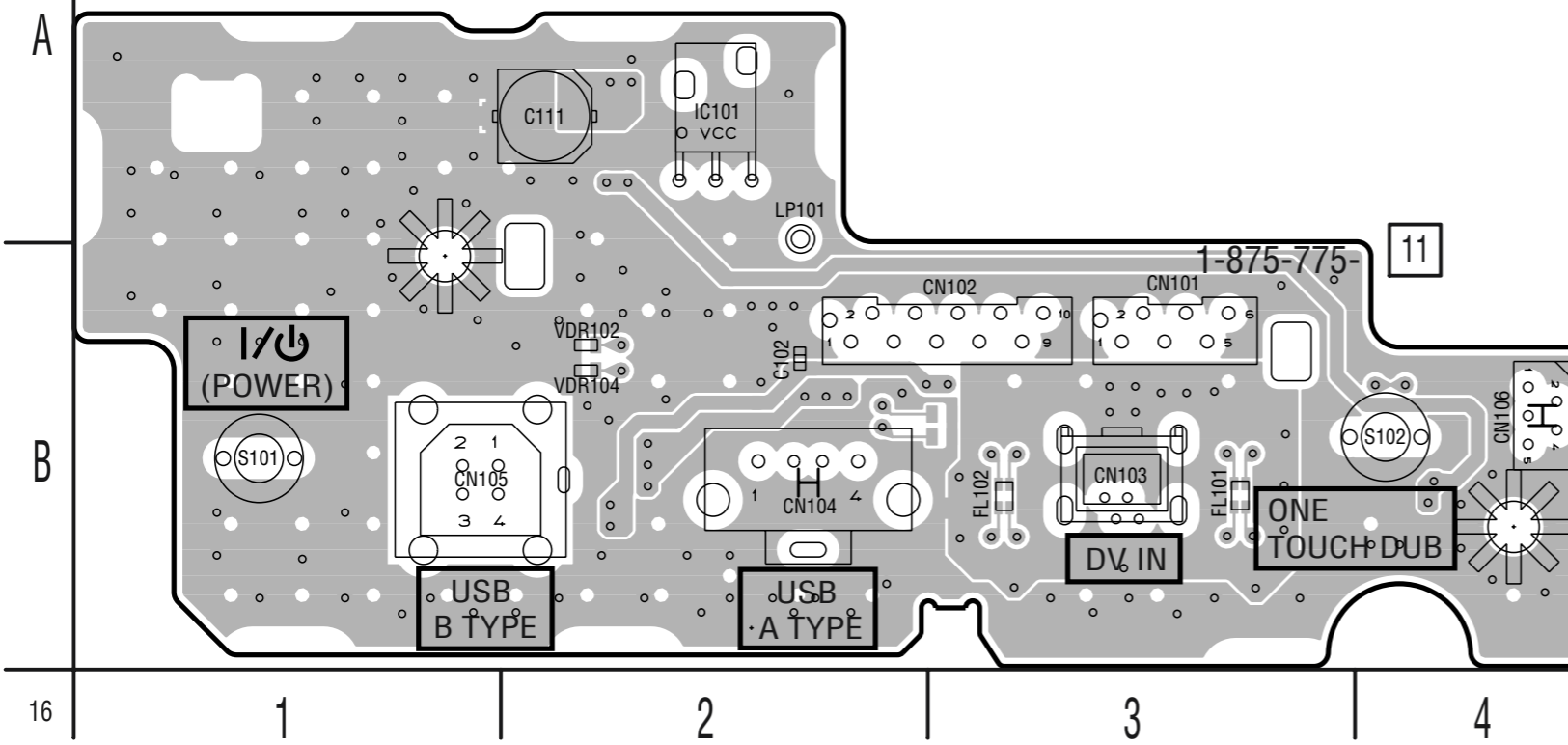

FL-184 BOARD(SIDE B)

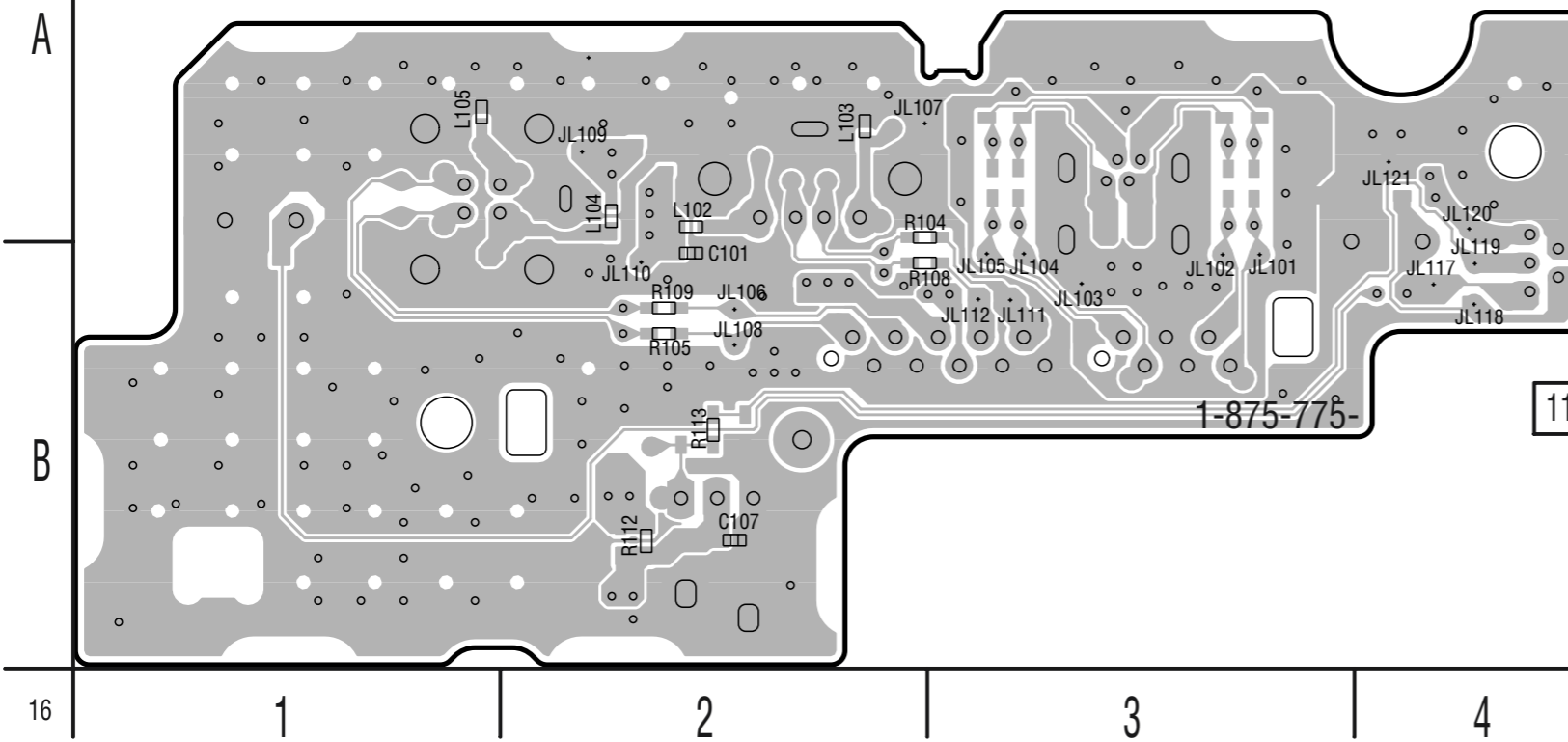

SECTION 5

IC PIN FUNCTION DESCRIPTION

5-1. IT CONTROL IC

(IC101:LC87F06J2A-F59P6-E (AV-133 BOARD))

Pin No.	Pin Name	I/O	Function
1	NC	—	Not used
2	NC	—	Not used
3	NC	—	Not used
4	WDT	—	Fixed at “H”
5	ACDET	I	Input of IC’s VDD detect signal
6	HSM_TO_T	I	Input of ROM/GIO address signal for IC1001 (RD-066 board)
7	IR	I	Input of remote control receive signal
8	RESET	I	Input of system reset signal
9	TX1	I	Input of sub-clock (32.768KHz)
10	TX2	O	Output of sub-clock (32.768KHz)
11	GND	—	Analog GND
12	CF1	I	Input of main-clock (15MHz)
13	CF2	O	Output of main-clock (15MHz)
14	VDD1	—	Power supply input
15	MODEL1	—	Fixed at “H”
16	MODEL2	—	Fixed at “GND”
17	KEY1	I	Input of function key signal [1]
18	KEY2	I	Input of function key signal [2]
19	KEY3	I	Input of function key signal [3]
20	AGC	I	Input of auto gain control signal
21	BATTDET	—	Fixed at “H”
22	FUNC	I	Input of detection signal for euro-scart
23	SDET3	—	Fixed at “H”
24	SDET2	I	Input of line 2 S-video detection signal
25	SDET1	—	Fixed at “H”
26	AVLOUT	O	Output of n-link switch signal
27	SDA	I/O	Input/output of IIC data signal
28	SCL	O	Output of IIC clock signal
29	XRST	O	Output of system reset signal for EURO MSP
30	NC	—	Not used
31	AFT	I	Input of tuner AFT control signal
32	NC	—	Not used
33	XAMUTE	I	Input of audio muting signal
34	RCSEL1	O	Output of R/C select signal [1]
35	RCSEL2	O	Output of R/C select signal [2]
36	NC	—	Not used
37	DDCSW1	O	Output of DDC IC switching signal [1]
38	DDCSW2	O	Output of DDC IC switching signal [2]
39	GND	—	Analog GND
40	VDD4	—	Power supply input
41	FUNC ON	O	Output of detection signal for euro-scart
42	SQUEEZE	O	Output of detection signal for euro-scart
43	CAPACTIOR	I	Input of IC’s VDD detect signal
44	NC	—	Not used
45	BLAIR	O	Output of transmission pulse for G-Link
46	P_SAVE	O	Output of power save signal for AV select IC’s
47	XSCMUTE	O	Output of SA mute control signal
48	AVLTH	O	Output of N-link switch drive signal
49	FLDATA	O	Output of data signal for FLD drive
50	FLSTB	O	Output of strove signal for FLD driver

Pin No.	Pin Name	I/O	Function
51	FLCLK	O	Output of clock signal for FLD driver
52	RFTHRU	O	Output of tuner power supply control signal
53	NC	—	Not used
54	FANCTL	O	Output of fan direction speed switching signal
55	VDD2	—	Power supply input
56	GND	—	Analog GND
57	P_CONT2	O	Output of system power supply control signal [2]
58	MUTECTL	O	Output of SA mute control signal
59	EPGEQ	O	Output of equalizer switching signal (AEP/UK model only)
60	TUON	O	Output of tuner block power supply control signal
61	SWVION9V	O	Output of system power supply control signal
62	P_CONT	O	Output of switching regulator control signal
63	FLON	O	Output of FLD grid power supply on signal
64	SWVION5V	O	Output of system power supply control signal
65	MRST	I	Input of system reset signal
66	NC(IN)	—	Fixed at “L”
67	CSYNCIN	I	Input of C-synchronization/composite video signal
68	XCHECKER	—	Not used
69	CEC	I	Input of CEC signal
70	AVLIN	I	Input of n-link switching signal
71	MSPSTAT	I	Input of starting signal for euro SMP IC's
72	BLANK	I	Input of blanking signal for euro scart
73	HOTPLUG	O	Output of hot plug detect signal
74	TU_DCCON	O	Output of tuner power supply control signal
75	TXD1	O	Output of serial TXD signal [1] (Not used)
76	RXD1	I	Input of serial RXD signal [1] (Not used)
77	TXD2	—	Not used
78	RXD2	—	Fixed at “L”
79	HST_TO_M	O	Output of ROM/GID address signal to IC1001 (RD-066 board)
80	VDDODA	—	Power supply input
81	CVBSIN	I	Input of composite video signal
82	GND	—	Analog GND
83	FILTSLC	—	Fixed at “L”
84	VDDVCO	—	Power supply input
85	DTBON	O	Output of tuner power supply control signal
86	ANT5V_SW	O	Output of system power supply control signal
87	DET_ANT	O	Output of tuner on detect signal
88	GND	—	Analog GND
89	VDD3	—	Power supply input
90	DBGP2	I	Checking terminal [2] (Fixed at “H”)
91	DBGP1	I	Checking terminal [1] (Fixed at “H”)
92	DGBP0	I	Checking terminal [0] (Fixed at “H”)
93	LED_PLTB	—	Not used
94	LED_DIVX	—	Not used
95	LED_D_TV	—	Not used
96	LED_A_TV	—	Not used
97	LED_HDD2	—	Not used
98	DAT_TO_M	O	Output of serial data signal to ENC/DEC IC's
99	DAM_TO_T	I	Input of serial data signal from ENC/DEC IC's
100	ASCK	I	Input of serial clock signal from ENC/DEC IC's

5-2. AV ENCODER/DECODER IC (IC1001:MC10050F1-505-LU1-A (RD-066 BOARD))

Pin No.	Pin Name	I/O	Function
A1	DGND	—	Digital GND
A2	DRASB	O	Output of RAS signal
A3	DBA1	O	Output of bank address [1]
A4	DADD01	O	Output of DDRSDRAM address [1]
A5	DDQM1	O	Output of data mask [1]
A6	DQ13	I/O	Input/output of DDRSDRAM data [13]
A7	DQ11	I/O	Input/output of DDRSDRAM data [11]
A8	DQ08	I/O	Input/output of DDRSDRAM data [8]
A9	DIHM	—	Fixed at “L”
A10	Not open to public	O	Output of power down
A11	Not open to public	O	Output of data [10]
A12	Not open to public	O	Output of data [7]
A13	Not open to public	O	Output of l clock
A14	Not open to public	O	Output of data [3]
A15	Not open to public	O	Output of data [0]
A16	Not open to public	O	Output of vertical synchronization
A17	Not open to public	I/O	Input/output of DDC data
A18	SS0DOUT	O	Output of serial data
A19	DA2_GND	—	GND (for DAC)
A20	VAY	O	Output of DA converter for analog video signal Y
A21	RSET1	—	Fixed at “L”
A22	VAR	O	Output of DA converter for analog video signal red
A23	RSET0	—	Fixed at “L”
A24	VAB	O	Output of DA converter for analog video signal blue
AA1	MD14	I/O	Input/output of buffer memory interface data bus [14]
AA2	LDQM	O	Output of lower byte data I/O mask control
AA3	MD5	I/O	Input/output of buffer memory interface data bus [5]
AA4	MD1	I/O	Input/output of buffer memory interface data bus [1]
AA5	MD3	I/O	Input/output of buffer memory interface data bus [3]
AA6	DVDD15(1.5V)	—	Power supply input
AA19	GPIO40	—	Fixed at “L”
AA20	AIOBCK	I/O	Input/output of audio data clock
AA21	RDATA02	I/O	Input/output of ROM/GIO data [2]
AA22	RADD03	O	Output of ROM/GIO address [3]
AA23	RADD08	O	Output of ROM/GIO address [8]
AA24	FWEB/GWEB	O	Output of ROM/GIO write enable
AB1	MD2	I/O	Input/output of buffer memory interface data bus [2]
AB2	UDQM	O	Output of upper byte data I/O mask control
AB3	MD4	I/O	Input/output of buffer memory interface data bus [4]
AB4	MCLKOUT	O	Output of clock for SDRAM
AB5	MD13	I/O	Input/output of buffer memory interface data bus [13]
AB6	DVDD15(1.5V)	—	Power supply input
AB19	CTS1B	I	Input of clear to send
AB20	VIOCLK	O	Output of video pixel clock
AB21	SP1CLK	—	Fixed at GND
AB22	AIOBD	I/O	Input/output of audio bitstream data
AB23	SP1STRT	—	Fixed at GND
AB24	RADD15	O	Output of ROM/GIO address [15]
AC1	MA9	O	Output of buffer memory interface address bus [9]
AC2	MD12	I/O	Input/output of buffer memory interface data bus [12]
AC3	MA10	O	Output of buffer memory interface address bus [10]
AC4	MCKE	O	Output of SDRAM clock enable control
AC5	MA7	O	Output of buffer memory interface address bus [7]

Pin No.	Pin Name	I/O	Function
AC6	PDIAGB	—	Not used
AC19	MONI3	—	Not used
AC20	SP1EN	—	Fixed at GND
AC21	SP1DAT2	—	Fixed at GND
AC22	VIOD7	I/O	Input/output of digital video data [7]
AC23	SP1DAT7	—	Fixed at GND
AC24	VIOD6	I/O	Input/output of digital video data [6]
AD1	MA6	O	Output of buffer memory interface address bus [6]
AD2	MA5	O	Output of buffer memory interface address bus [5]
AD3	MA1	O	Output of buffer memory interface address bus [1]
AD4	MA8	O	Output of buffer memory interface address bus [8]
AD5	MBA	O	Output of buffer memory interface bank address
AD6	DASPB	—	Not used
AD7	HIOCS16B	—	Not used
AD8	SFSO	O	Output of serial flash interface data
AD9	SFCK	O	Output of serial flash interface clock
AD10	SFSI	I	Input of serial flash interface data
AD11	SFCS0B	O	Output of serial flash command (address)
AD12	AVDD15	—	Power supply input (Analog 1.5V)
AD13	AVDD33	—	Power supply input (Analog 3.0V)
AD14	AVDD33	—	Power supply input (Analog 3.0V)
AD15	AVDD33	—	Power supply input (Analog 3.0V)
AD16	AVDD33	—	Power supply input (Analog 3.0V)
AD17	TEST1	—	Not used
AD18	MONI1	—	Not used
AD19	MONI2	—	Not used
AD20	SP1ERRB	—	Fixed at GND
AD21	SP1DAT6	—	Fixed at GND
AD22	SP1DAT5	—	Fixed at GND
AD23	VIOD5	I/O	Input/output of digital video data [5]
AD24	VIOD3	I/O	Input/output of digital video data [3]
AE1	XA1	I	Input of clock 16.9344MHz
AE2	CASB	O	Output of buffer memory interface column address strove control
AE3	MA0	O	Output of buffer memory interface address bus [0]
AE4	MA4	O	Output of buffer memory interface address bus [4]
AE5	MA3	O	Output of buffer memory interface address bus [3]
AE6	PB4	O	Output of LDD signal
AE7	PB1	I	Input of 3 value control switch
AE8	RLDM	I	Input of laser driver control amplifier (-) for read
AE9	WLD	O	Output of laser driver control for write
AE10	WLDM	I	Input of laser driver control amplifier (-) for write
AE11	PLED	O	Output of peak power signal
AE12	CWAGC	—	Fixed at “L”
AE13	CWHP	—	Fixed at “L”
AE14	CAD	—	Fixed at “L”
AE15	CBC	—	Fixed at “L”
AE16	CTEC	—	Fixed at “L”
AE17	CRC	—	Fixed at “L”
AE18	CBHLPP/CRAPC	—	Fixed at “L”
AE19	ADIN	—	Not used
AE20	AIOLRCK	I/O	Input/output of audio L/R clock
AE21	VIOD2	I/O	Input/output of digital video data [2]
AE22	SP1DAT3	—	Fixed at GND

Pin No.	Pin Name	I/O	Function
AE23	SP1DAT4	—	Fixed at GND
AE24	VIOD1	I/O	Input/output of digital video data [1]
AF1	XA2	I/O	Input/output of clock 16.9344MHz
AF2	WEB	O	Output of buffer memory interface write enable
AF3	MA2	O	Output of buffer memory interface address bus [2]
AF4	RSAB	O	Output of buffer memory interface row address strove control
AF5	(PB2)	O	Output of buffer memory interface bank address [MA11]
AF6	PB5	O	Output of DDO
AF7	PB7	I	Input of DMS
AF8	RLD	O	Output of laser driver control for read
AF9	REF16	O	Output of internal reference voltage
AF10	VREFIO	O	Output of pick-up reference voltage
AF11	P2LD	O	Output of peak power signal 2
AF12	CADO	—	Fixed at “L”
AF13	CBHWBL/CID	—	Fixed at “L”
AF14	CAMIRR	—	Fixed at “L”
AF15	CBPD	—	Fixed at “L”
AF16	CAGC	—	Fixed at “L”
AF17	CAGC2	—	Fixed at “L”
AF18	CEQDC	—	Fixed at “L”
AF19	FE0	—	Not used
AF20	TE0	—	Not used
AF21	TXD0B	O	Output of transfer data [0]
AF22	RXD0B	I	Input of receive data [0]
AF23	VIOD4	I/O	Input/output of digital video data [4]
AF24	VIOD0	I/O	Input/output of digital video data [0]
AG1	PB3	O	Output of RAMWR signal
AG2	PA0	O	Output of data carrier detect signal to D18
AG3	PA4	—	Fixed at “L”
AG4	PB0	I	Input of 3 value control switch
AG5	PB6	O	Output of RXDA2 signal
AG6	PA3	O	Output of RCKK signal
AG7	PA5	—	Fixed at “L”
AG8	PDIN	I	Input of laser moniter signal
AG9	FPDVI	I	Input of reference voltage for front moniter
AG10	FPDVO	—	Fixed at “L”
AG11	CREG	—	Fixed at “L”
AG12	CBCO	—	Fixed at “L”
AG13	WALPF	—	Fixed at “L”
AG14	CMIRR	—	Fixed at “L”
AG15	CBBB	—	Fixed at “L”
AG16	REFQOM	O	Output of differential RF signal (-) to AH16 pin
AG17	REFQOP	O	Output of differential RF signal (+) to AH17 pin
AG18	RFO	—	Fixed at “L”
AG19	CDEF	—	Fixed at “L”
AG20	FG	I	Input of FG signal
AG21	RFP1	O	Output of RF digital signal
AG22	RXD1B	I	Input of receive data [1]
AG23	TXD1B	O	Output of transfer data [1]
AG24	SP1DAT1	—	Fixed at GND
AH1	PKPULSE1M	O	Output of peak pulse (laser drive control signal for write)
AH2	PKPULSE1P	O	Output of peak pulse (laser drive control signal for write)
AH3	WRPULSEM	O	Output of write pulse (laser drive control signal for write)

Pin No.	Pin Name	I/O	Function
AH4	WRPULSEP	O	Output of write pulse (laser driver control signal for write)
AH5	HFONP	O	Output of laser driver high frequency superposition control signal
AH6	PA7	I	Input of RXDA2 signal
AH7	PA2	O	Output of RCDT signal
AH8	H1	I	Input of sub beam signal H1
AH9	G1/FOP	I	Input of sub beam signal G1
AH10	F1	I	Input of sub beam signal F1
AH11	E1	I	Input of sub beam signal E1
AH12	REP	I	Input of RF differential signal (+)
AH13	ASY	—	Fixed at “L”
AH14	FCEFM2	—	Fixed at “L”
AH15	PCEFM2	—	Fixed at “L”
AH16	RFI_M	I	Input of differential RF signal (-) from AG16 pin
AH17	RFI_P	I	Input of differential RF signal (+) from AG17 pin
AH18	AGCIN	—	Fixed at “L”
AH19	CDEF2	—	Fixed at “L”
AH20	TDRV	O	Output of tracking drive signal (D/A converter)
AH21	FDRV	O	Output of Focuse drive signal (D/A converter)
AH22	RFP2	O	Output of RF digital signal
AH23	RXD2B	I	Input of receive data
AH24	SP1DAT0	—	Fixed at GND
AJ1	OFPULSE	—	Not used
AJ2	OFPULSE	O	Output of off pulse signal
AJ3	PKPULSE2	O	Output of peak pulse
AJ4	PKPULSE2	O	Output of peak pulse
AJ5	HFONM	O	Output of laser drive high frequency superposition control signal
AJ6	PA1	O	Fixed at “L”
AJ7	PA6	I	Input of RCDT signal
AJ8	D1	I	Input of main beam signal D1
AJ9	C1	I	Input of main beam signal C1
AJ10	B1	I	Input of main beam signal B1
AJ11	A1	I	Input of main beam signal A1
AJ12	RFN	I	Input of RF differential signal (-)
AJ13	EFM	—	Fixed at “L”
AJ14	FCEFM1	I	Read channel frequency comparator
AJ15	PCEFM1	—	Fixed at “L”
AJ16	EXTR	—	Fixed at “L”
AJ17	CEQ	—	Fixed at “L”
AJ18	REQ	—	Fixed at “L”
AJ19	DAOUT	O	Output of general-purpose D/A converter
AJ20	SDRV2	O	Output of sled drive signal (D/A converter)
AJ21	SDRV1	O	Output of sled drive signal (D/A converter)
AJ22	MDRV	O	Output of spindle drive signal (D/A converter)
AJ23	RPF3	I	Input of RF digital signal
AJ24	TXD2B	O	Output of transfer data
B1	DCLKB	O	Output of negative clock for DDRSDRAM
B2	DCASB	O	Output of CAS signal
B3	DBA0	O	Output of bank address [0]
B4	DADD00	O	Output of DDRSDRAM address [0]
B5	DADD03	O	Output of DDRSDRAM address [3]
B6	DQ12	I/O	Input/output of DDRSDRAM data [12]
B7	DQ15	I/O	Input/output of DDRSDRAM data [15]
B8	DQ09	I/O	Input/output of DDRSDRAM data [9]

Pin No.	Pin Name	I/O	Function
B9	DDQM3	O	Output of data mask [3]
B10	Not open to public	I	Input of monitor sense
B11	Not open to public	O	Output of data [11]
B12	Not open to public	O	Output of data [8]
B13	Not open to public	O	Output of data [5]
B14	Not open to public	O	Output of data [2]
B15	Not open to public	O	Output of data enable
B16	Not open to public	O	Output of CTL signal [3]
B17	Not open to public	I/O	Input/output of DDC clock
B18	SS0CKIN	I	Input of serial clock signal
B19	DA2_VDD3	—	Power supply input (3.0V for DAC)
B20	COMP1	—	Fixed at “L”
B21	VAC	O	Output of DA converter for video signal chrominance
B22	VREF	I	Input of DA converter for reference voltage
B23	VAG	O	Output of DA converter for analog video signal green/Y
B24	COMP0	—	Fixed at “L”
C1	DCLK	O	Output of positive clock for DDRSDRAM
C2	DWEB	O	Output of command write enable
C3	DCS0B	O	Output of DDRSDRAM chip select [0]
C4	DADD10	O	Output of DDRSDRAM address [10]
C5	DADD02	O	Output of DDRSDRAM address [2]
C6	DDQS1	I/O	Input/output of data strobe [1]
C7	DQ14	I/O	Input/output of DDRSDRAM data [14]
C8	DQ10	I/O	Input/output of DDRSDRAM data [10]
C9	DDQS3	I/O	Input/output of data strobe [3]
C10	DILM	—	Fixed at “H”
C11	Not open to public	O	Output of CTL signal [2]
C12	Not open to public	O	Output of data [9]
C13	Not open to public	O	Output of data [6]
C14	Not open to public	O	Output of data [4]
C15	Not open to public	O	Output of data [1]
C16	Not open to public	O	Output of horizontal synchronization
C17	Not open to public	I	Input of hot plug detect
C18	SDA1	I/O	Input/output of serial data
C19	AOBCK	O	Output of audio data clock
C20	AIOMCK0	I/O	Input/output of audio master clock [0]
C21	DA1_VDD3	—	Power supply input (3.0V for DAC)
C22	DA1_GND	—	GND (for DAC)
C23	VCOMB	—	Fixed at “L”
C24	VRTB	—	Fixed at “L”
D1	DADD06	O	Output of DDRSDRAM address [6]
D2	DADD07	O	Output of DDRSDRAM address [7]
D3	DADD08	O	Output of DDRSDRAM address [8]
D4	DADD11	O	Output of DDRSDRAM address [11]
D5	DCKE	O	Output of clock enable
D6	DQ30	I/O	Input/output of DDRSDRAM data [30]
D7	DQ28	I/O	Input/output of DDRSDRAM data [28]
D8	DQ26	I/O	Input/output of DDRSDRAM data [26]
D9	DQ24	I/O	Input/output of DDRSDRAM data [24]
D10	PHY_D7	I/O	Input/output of PHY-link data [7] for PHY
D11	PHY_D5	I/O	Input/output of PHY-link data [5] for PHY
D12	PHY_D3	I/O	Input/output of PHY-link data [3] for PHY
D13	PHY_D1	I/O	Input/output of PHY-link data [1] for PHY

Pin No.	Pin Name	I/O	Function
D14	CTL1	I/O	Input/output of PHY/link control [1] for PHY
D15	SCLK	I	Input of link control clock for PHY
D16	LPS	O	Output of link power status
D17	SCL1	I/O	Input/output of serial clock
D18	DCD0B	I	Input of data carrier detect from AG2 pin
D19	ATX	O	Output of digital audio
D20	AOLRCK	O	Output of audio L/R clock
D21	VCOMY	—	Fixed at “L”
D22	VRTY	—	Fixed at “L”
D23	ABI	I	Input of AD converter for analog video signal green
D24	VRBB	—	Fixed at “L”
E1	DADD04	O	Output of DDRSDRAM address [4]
E2	DADD05	O	Output of DDRSDRAM address [5]
E3	DCS1B	—	Not connected
E4	DADD09	O	Output of DDRSDRAM address [9]
E5	DADD12	O	Output of DDRSDRAM address [12]
E6	DQ31	I/O	Input/output of DDRSDRAM data [31]
E7	DQ29	I/O	Input/output of DDRSDRAM data [29]
E8	DQ27	I/O	Input/output of DDRSDRAM data [27]
E9	DQ25	I/O	Input/output of DDRSDRAM data [25]
E10	PHY_D6	I/O	Input/output of PHY-link data [6] for PHY
E11	PHY_D4	I/O	Input/output of PHY-link data [4] for PHY
E12	PHY_D2	I/O	Input/output of PHY-link data [2] for PHY
E13	PHY_D0	I/O	Input/output of PHY-link data [0] for PHY
E14	CTL0	I/O	Input/output of PHY/link control [0] for PHY
E15	LREQ	O	Output of link request for PHY
E16	LINKON	I	Input of LINK on
E17	SS0DIN	I	Input of serial data
E18	AOD0	O	Output of audio bitstream data L/R
E19	AIBCK0	I	Input of audio data clock
E20	AIBD0	I	Input of audio bitstream data [0]
E21	AIOMCK1	I/O	Input/output of audio master clock [1]
E22	VRBY	—	Fixed at “L”
E23	VCLY	—	Fixed at “L”
E24	AYI	I	Input of AD converter for analog video signal Y
F1	DQ19	I/O	Input/output of DDRSDRAM data [19]
F2	DDQS0	I/O	Input/output of data strobe [0]
F3	DDQM0	O	Output of data mask [0]
F4	DQ01	I/O	Input/output of DDRSDRAM data [1]
F5	DQ00	I/O	Input/output of DDRSDRAM data [0]
F6	DVREF	—	Input of reference voltage from DDRSDRAM
F7	DVDD25(2.5V)	—	Power supply input
F8	DVDD25(2.5V)	—	Power supply input
F9	DVDD25(2.5V)	—	Power supply input
F10	DVDD25(2.5V)	—	Power supply input
F11	DVDD25(2.5V)	—	Power supply input
F12	DGND	—	Digital GND
F13	DGND	—	Digital GND
F14	DGND	—	Digital GND
F15	DGND	—	Digital GND
F16	DGND	—	Digital GND
F17	GPIO54	O	Output of audio mute
F18	IR_OUT	O	Output of IR transmitter

Pin No.	Pin Name	I/O	Function
F19	AILRCK0	I	Input of audio L/R clock [0]
F20	IR_IN	I	Input of IR receiver
F21	JTDI	I	Input of EJTAG data
F22	VRTR	—	Fixed at “L”
F23	ARI	I	Input of AD converter for analog video signal blue
F24	VRBR	—	Fixed at “L”
G1	DQ16	I/O	Input/output of DDRSDRAM data [16]
G2	DQ17	I/O	Input/output of DDRSDRAM data [17]
G3	DQ18	I/O	Input/output of DDRSDRAM data [18]
G4	DQ03	I/O	Input/output of DDRSDRAM data [3]
G5	DQ02	I/O	Input/output of DDRSDRAM data [2]
G6	DVDD25(2.5V)	—	Power supply input
G7	DVDD25(2.5V)	—	Power supply input
G19	JTDO	O	Output of EJTAG data
G20	JTMS	I	Input of EJTAG mode set
G21	VCOMR	—	Fixed at “L”
G22	VRTC	—	Fixed at “L”
G23	VRBC	—	Fixed at “L”
G24	ACI	I	Input of AD converter for analog video signal chrominance or red
H1	DQ22	I/O	Input/output of DDRSDRAM data [22]
H2	DQ21	I/O	Input/output of DDRSDRAM data [21]
H3	DQ20	I/O	Input/output of DDRSDRAM data [20]
H4	DQ06	I/O	Input/output of DDRSDRAM data [6]
H5	DQ07	I/O	Input/output of DDRSDRAM data [7]
H6	DVDD25(2.5V)	—	Power supply input
H19	EDINT	I	Input of EJTAG DINT
H20	JTRST	I	Input of EJTAG reset
H21	HLCI	I	Input of H lock clock for video decoder
H22	VCOMC	—	Fixed at “L”
H23	AD2_VDD3	—	Power supply input (3.0V for ADC)
H24	AD2_GND	—	GND (for ADC)
J1	DDQM2	O	Output of data mask [2]
J2	DDQS2	I/O	Input/output of data strobe [2]
J3	DQ23	I/O	Input/output of DDRSDRAM data [23]
J4	DQ04	I/O	Input/output of DDRSDRAM data [4]
J5	DQ05	I/O	Input/output of DDRSDRAM data [5]
J6	DVDD25(2.5V)	—	Power supply input
J19	JTCL	I	Input of EJTAG clock
J20	PH_VDD1	—	Power supply input (1.0V for V DEC)
J21	HCBP	—	Fixed at “L”
J22	FCBP	—	Fixed at “L”
J23	PF_GND	—	GND (for V DEC)
J24	FSCI	I	Input of FSC for video decoder
K1	PLL_VDD	—	Power supply input (1.0V for PLL)
K2	CLK27AOUT	O	Output of 27MHz clock A
K3	CLKPWM0	O	Output of PWM for 27MHz VCXO [0]
K4	CLKPWM1	O	Output of PWM for 27MHz VCXO [1]
K5	SMCKOUT	O	Output of serial clock
K6	DVDD25(2.5V)	—	Power supply input
K10	DGND	—	Digital GND
K11	DGND	—	Digital GND
K12	DVDD33(3.3V)	—	Power supply input
K13	DVDD33(3.3V)	—	Power supply input

Pin No.	Pin Name	I/O	Function
K14	DVDD33(3.3V)	—	Power supply input
K15	DVDD33(3.3V)	—	Power supply input
K19	DGNDR	—	GND (for RF)
K20	HLCO	O	Output of H lock clock for video decoder
K21	HC_VDD3	—	Power supply input (3.0V for V DEC)
K22	FC_VDD3	—	Power supply input (3.0V for V DEC)
K23	FSCO	O	Output of FSC for video decoder
K24	PF_VDD1	—	Power supply input (1.0V for V DEC)
L1	CLK27AIN	I	Input of 27MHz clock A
L2	PLL_GND	—	GND (for PLL)
L3	CLK27BIN	I	Input of 27MHz clock B
L4	SMDOUT	O	Output of serial data
L5	SMDIN	I	Input of serial data
L6	DLL_VDD	—	Power supply input (1.0V for DLL)
L10	DGND	—	Digital GND
L11	DVDD33(3.3V)	—	Power supply input
L12	DVDD33(3.3V)	—	Power supply input
L13	DVDD33(3.3V)	—	Power supply input
L14	DVDD33(3.3V)	—	Power supply input
L15	DVDD33(3.3V)	—	Power supply input
L19	HXT_CSDA	I/O	Input/output of serial data for HDMI debug
L20	NMI	—	Fixed at “H”
L21	RSTSWB	I	Input of system reset
L22	PH_GND	—	GND (for V DEC)
L23	AD1_VDD3	—	Power supply input (3.0V for ADC)
L24	CLK24OUT	O	Output of 24MHz clock
M1	USB_DN0	I/O	Input/output of USB D-
M2	USB_DP0	I/O	Input/output of USB D+
M3	USB_H_OCI0	I	Input of USB over-current status
M4	AT1D00	I/O	Input/output of IDE I/F data [0]
M5	AT1INTRQ	I	Input of IRQ signal
M6	DLL_GND	—	GND (for DLL)
M10	TEST_MODE	—	Fixed at GND
M11	FPIND	—	Fixed at GND
M12	LVSPOWD	—	Fixed at “H”
M13	DVDD33(3.3V)	—	Power supply input
M14	DVDD33(3.3V)	—	Power supply input
M15	DVDD33(3.3V)	—	Power supply input
M19	SCL0	I	Input of serial clock
M20	RADD23	—	Fixed at “L”
M21	RADD17	O	Output of ROM/GIO address [17]
M22	RDATA09	I/O	Input/output of ROM/GIO data [9]
M23	AD1_GND	—	GND (for ADC)
M24	CLK24IN	I	Input of 24MHz clock
N1	USB_CLKI	I	Input of USB clock
N2	USB_H_PPON0	O	Output of USB power control
N3	USB_D_VBUS	I	Input of USB VBUS
N4	AT1D13	I/O	Input/output of IDE I/F data [13]
N5	AT1D04	I/O	Input/output of IDE I/F data [4]
N6	DGND	—	Digital GND
N10	DVDD10(1.0V)	—	Power supply input
N11	DVDD10(1.0V)	—	Power supply input
N12	DVDD10(1.0V)	—	Power supply input

Pin No.	Pin Name	I/O	Function
N13	DVDD10(1.0V)	—	Power supply input
N14	DVDD33(3.3V)	—	Power supply input
N15	AVDD33R	—	Power supply input (3.0V for RF)
N19	RADD24	I	Input of ROM/GIO address [24]
N20	RDATA14	I/O	Input/output of ROM/GIO data [14]
N21	RADD18	O	Output of ROM/GIO address [18]
N22	RDATA13	I/O	Input/output of ROM/GIO data [13]
N23	RDATA07	I/O	Input/output of ROM/GIO data [7]
N24	DGND	—	Digital GND
P1	USB_D_DN0	I/O	Input/output of USB D-
P2	USB_D_DP0	I/O	Input/output of USB D+
P3	USB_D_CONNECT	O	Connection control of the pull-up resistance of D+
P4	AT1D06	I/O	Input/output of IDE I/F data [6]
P5	AT1D09	I/O	Input/output of IDE I/F data [9]
P6	DGND	—	Digital GND
P10	DVDD10(1.0V)	—	Power supply input
P11	DVDD10(1.0V)	—	Power supply input
P12	DVDD10(1.0V)	—	Power supply input
P13	AT0D06	O	Output of data [06] for IDE I/F
P14	AT0DIOWB	O	Output of DIOW signal for IDE I/F
P15	AT0D10	O	Output of data [10] for IDE I/F
P19	RADD25	O	Output of ROM/GIO address [25]
P20	RADD00	—	Fixed at “L”
P21	RDATA12	I/O	Input/output of ROM/GIO data [12]
P22	RADD10	O	Output of ROM/GIO address [10]
P23	RADD12	O	Output of ROM/GIO address [12]
P24	RADD22	O	Output of ROM/GIO address [22]
R1	AT1D01	I/O	Input/output of IDE I/F data [1]
R2	AT1D03	I/O	Input/output of IDE I/F data [3]
R3	AT1D05	I/O	Input/output of IDE I/F data [5]
R4	AT1D02	I/O	Input/output of IDE I/F data [2]
R5	AT1D11	I/O	Input/output of IDE I/F data [11]
R6	DGND	—	Digital GND
R10	DVDD10(1.0V)	—	Power supply input
R11	DVDD10(1.0V)	—	Power supply input
R12	AT0DIORB	O	Output of DIOR signal for IDE I/F
R13	AT0D08	O	Output of data [08] for IDE I/F
R14	AT0D12	O	Output of data [12] for IDE I/F
R15	AT0D07	O	Output of data [07] for IDE I/F
R19	GCSB2	O	Output of GIO chip select [2]
R20	GRDYB	I	Input of GIO READY
R21	RDATA15	I/O	Input/output of ROM/GIO data [15]
R22	RADD20	O	Output of ROM/GIO address [20]
R23	RDATA08	I/O	Input/output of ROM/GIO data [8]
R24	RADD16	O	Output of ROM/GIO address [16]
T1	AT1D07	I/O	Input/output of IDE I/F data [7]
T2	AT1D08	I/O	Input/output of IDE I/F data [8]
T3	AT1D10	I/O	Input/output of IDE I/F data [10]
T4	AT1CS0B	O	Output of chip select [0] for HDD
T5	AT1DA2	O	Output of IDE I/F address [2]
T6	DGND	—	Digital GND
T10	DVDD10(1.0V)	—	Power supply input
T11	DVDD10(1.0V)	—	Power supply input

Pin No.	Pin Name	I/O	Function
T12	AT0D05	O	Output of data [05] for IDE I/F
T13	AT0IORDY	O	Output of IORDY signal for IDE I/F
T14	AT0D15	O	Output of data [15] for IDE I/F
T15	AT0DMARQ	O	Output of DMARQ signal for IDE I/F
T19	GCSB3	O	Output of GIO chip select [3]
T20	GCSB1	—	Not used
T21	RDATA11	I/O	Input/output of ROM/GIO data [11]
T22	RDATA10	I/O	Input/output of ROM/GIO data [10]
T23	RADD19	O	Output of ROM/GIO address [19]
T24	RDATA05	I/O	Input/output of ROM/GIO data [5]
U1	AT1D12	I/O	Input/output of IDE I/F data [12]
U2	AT1D14	I/O	Input/output of IDE I/F data [14]
U3	AT1DA0	O	Output of IDE I/F address [0]
U4	AT1IORDY	I	Input of I/O ready
U5	AT1DIOWB	O	Output of IDE I/F I/O write for HDD
U6	DGND	—	Digital GND
U10	AT0DA1	O	Output of address [1] for IDE I/F
U11	AT0D01	O	Output of data [01] for IDE I/F
U12	AT0D02	O	Output of data [02] for IDE I/F
U13	AT0D11	O	Output of data [11] for IDE I/F
U14	AT0DA2	O	Output of address [2] for IDE I/F
U15	AT0D13	O	Output of data [13] for IDE I/F
U19	GPIO37	I	Input of clear to send
U20	RADD14	O	Output of ROM/GIO address [14]
U21	RADD13	O	Output of ROM/GIO address [13]
U22	RADD11	O	Output of ROM/GIO address [11]
U23	RDATA03	I/O	Input/output of ROM/GIO data [3]
U24	RDATA06	I/O	Input/output of ROM/GIO data [6]
V1	AT1DIORB	O	Output of IDE I/F I/O read for HDD
V2	AT1DMACKB	O	Output of ACK signal
V3	AT1CS1B	O	Output of chip select [1] for HDD
V4	AT1RESETB	O	Output of HDD I/F reset
V5	AT1DMARQ	I	Input of REQ signal
V6	DGND	—	Digital GND
V10	AT0D09	O	Output of data [09] for IDE I/F
V11	AT0D04	O	Output of data [04] for IDE I/F
V12	AT0INTRQ	O	Output of INTRQ signal for IDE I/F
V13	AT0RESETB	O	Output of reset signal for IDE I/F
V14	AT0D00	O	Output of data [00] for IDE I/F
V15	AT0DMACKB	O	Output of DMC ACK signal for IDE I/F
V19	GPIO36	O	Output of select signal for SPDIF
V20	GCSB0	—	Not used
V21	RADD07	O	Output of ROM/GIO address [7]
V22	RDATA04	I/O	Input/output of ROM/GIO data [4]
V23	RADD05	O	Output of ROM/GIO address [5]
V24	FCSB0	O	Output of ROM chip select
W1	AT1D15	I/O	Input/output of IDE I/F data [15]
W2	AT1DA1	O	Output of IDE I/F address [1]
W3	MD9	I/O	Input/output of buffer memory interface data bus [9]
W4	MD6	I/O	Input/output of buffer memory interface data bus [6]
W5	MD8	I/O	Input/output of buffer memory interface data bus [8]
W6	DVDD15(1.5V)	—	Power supply input
W10	DGND	—	Digital GND

Pin No.	Pin Name	I/O	Function
W11	AT0CS1B	O	Output of chip select signal [1] for IDE I/F
W12	AT0CS0B	O	Output of chip select signal [0] for IDE I/F
W13	AT0D14	O	Output of data [14] for IDE I/F
W14	AT0DA0	O	Output of address [0] for IDE I/F
W15	AT0D03	O	Output of data [03] for IDE I/F
W19	SP1REQB	—	Fixed at GND
W20	RADD21	O	Output of ROM/GIO address [21]
W21	RDATA00	I/O	Input/output of ROM/GIO data [0]
W22	FOEB/GOEB	O	Output of ROM/GIO enable
W23	RADD04	O	Output of ROM/GIO address [4]
W24	FCSB1	—	Not used
Y1	MD15	I/O	Input/output of buffer memory interface data bus [15]
Y2	MD11	I/O	Input/output of buffer memory interface data bus [11]
Y3	MD0	I/O	Input/output of buffer memory interface data bus [0]
Y4	MD7	I/O	Input/output of buffer memory interface data bus [7]
Y5	MD10	I/O	Input/output of buffer memory interface data bus [10]
Y6	DVDD15(1.5V)	—	Power supply input
Y10	DGND	—	Digital GND
Y11	DGND	—	Digital GND
Y12	AGND	—	GND (Analog)
Y13	AGND	—	GND (Analog)
Y14	AGND	—	GND (Analog)
Y15	AGND	—	GND (Analog)
Y19	GPIO33	—	Fixed at “L”
Y20	RADD01	O	Output of ROM/GIO address [1]
Y21	RDATA01	I/O	Input/output of ROM/GIO data [1]
Y22	RADD09	O	Output of ROM/GIO address [9]
Y23	RADD06	O	Output of ROM/GIO address [6]
Y24	RADD02	O	Output of ROM/GIO address [2]

SECTION 6
SERVICE MODE

Preparing for Service tool

- Color monitor
- Service remote controller
(Part code: J-6090-203-A)

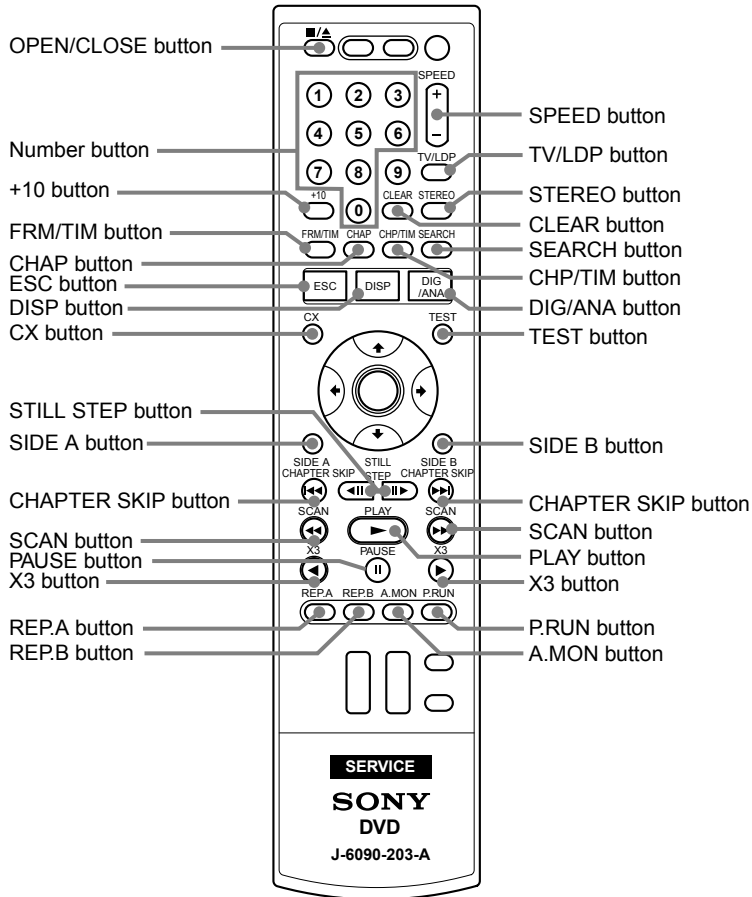

6-1. SERVICE MODE MAP

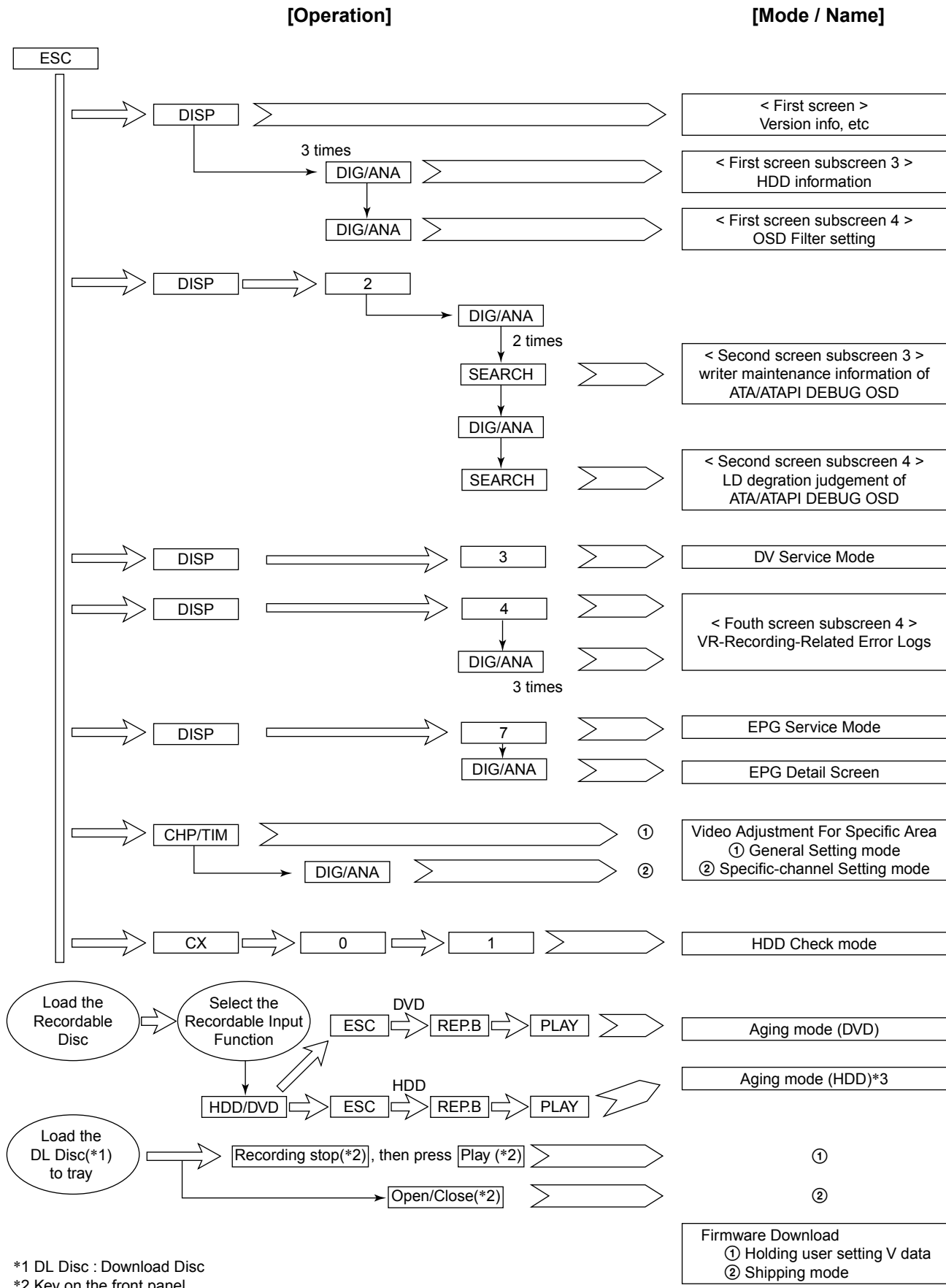

*1 DL Disc : Download Disc
*2 Key on the front panel

6-2. Diagnostic Mode

6-2-1. Model Setting

- 1) Turn of the main power ON.
- 2) On the screen after exiting all menu screens, press the following buttons “ESC” ⇒ “CHAP” ⇒ “1” on the service remote controller.
- 3) Turn of the main power OFF.
- 4) Turn of the main power ON.
- 5) Press four digits properly (Refer to page 5 service remote controller.) by using the according to the screen information.
- 6) Press the following buttons “ESC” ⇒ “CHAP” ⇒ “1” on the service remote controller.

```
[Recorder's Model Setting]
Input the number using the remote for Service.

>---

Input No.      Manufacturer
[ 0101      :          ]
[ 0201      :          ]
[ 0102      :          ]
[ 0202      :          ]
[ 0103      :          ]
[ 0203      :          ]
```

- 7) Disconnect then reconnect the AC power cord of the unit. Be careful not to impart vibration to the unit immediately after the AC power cord is disconnected.
- 8) Reset the recorder to all its factory settings.
(Make sure that the recorder is on. Press and hold “■” (STOP) key and press “⏻” (STANDBY/ON) key on the front panel.)
The recorder turns off with all settings reset.
- 9) Turn of the main power ON.
- 10) Press “ESC” then “DISP” keys by using the service remote controller and then confirm each Model Name.

```
-----          VERSION : -----
SYSCON   : RELEASE_100
          Rev    : 1.*****
TUNERCON : 198.000          OK
DRIVE    : DVD-RW DVR-L11X  OK
          1.00             OK

PIC SERIAL : -----
HDD INT   : -----

DEVICE   : -----          FLASH : 64M
REGION  : 2                C : *****
                                HDCP : -----
```

- 11) Press “ESC”. (Returns to the original screen)

6-2-2. Service Mode

- 1) Turn of the main power ON.
- 2) On the screen after exiting all menu screen's, press "ESC" on the service remote controller.
- 3) Press "DISP".
- 4) Press "DIG/ANA".

Overview and purposes

To be used to check the status of the product and to collect the information for failure diagnosis.

The following information to be used for servicing is displayed:

- [1] First screen : Version, HDD information, etc.
- [2] Second screen : ATA/ATAPI debug screen (Writer information)
- [4] Fourth screen : VR-recording-related error logs

Each screen has sublevel screens.

Note: After entering any Service mode screen, to shift to another Service mode screen, first quit that Service mode screen then enter another Service mode screen.

- 5) Press "ESC". (Returns to the original screen)

6-2-3. Version Information and Other Information (First screen)

- 1) Turn of the main power ON.
- 2) On the screen after exiting all menu screens, press "ESC" on the service remote controller.
- 3) Press "DISP".

* Checking the respective software version numbers and other HDD information.

①	-----	②	VERSION : 1.**	
③	SYSCON	:	RELEASE_100 Ver: 1.10034	
④	TUNERCON	:	198.000	OK
⑤	DRIVE	:	DVD-RW DVR-L11X 1.00	OK
⑥	HDD INT	:	WDC WD1600AAJS-9	160
	HDD USE	:		160
⑦	DEVICE	:	E2R-FEx1.1	⑧ FLASH : 64M
⑨	REGION	:	2	⑩ C : *****
			HDCP :	
	DTB H	:	455	DTB S : 107 OK
				DTB B : 107D OK

OK : Appropriate version compared with that of the firmware of the system control computer.

NG- : The version of the TUNER microcomputer is older.
Measures to be taken:
• Download the firmware.

OK : The appropriate drive is mounted.
NG : An inappropriate drive is mounted.
Measures to be taken: Download the firmware.

OK : Appropriate version compared with that of the firmware of the system control computer.
NG- : The version of the drive microcomputer is older.
Measures to be taken: Download the firmware.

- ① Model name/destination
- ② Version of the recorder software
- ③ Revision No. of the system-control computer software
- ④ Version No. of the tuner microcomputer
Result of the combination check with system microcomputer
- ⑤ Information on the built-in drive
(Model name, version No., model type)
- ⑥ Data of the built-in HDD, capacity of the HDD
- ⑦ DEVICE information (EMMA type, ES No.)
- ⑧ FLASH ROM information
- ⑨ Region No.
- ⑩ CPRM information (CPRM key No.)

- 4) Press "ESC". (Returns to the original screen)

6-2-4. RF Level Simplified Diagnosis (Subscreen1)

- 1) Turn of the main power ON.
- 2) On the screen after exiting all menu screens, press “ESC” on the service remote controller.
- 3) Press “DISP”.
- 4) Press “DIG/ANA”.

```

----          VERSION : 1.**
SYSCON   : RELEASE_***
           Rev       :1.*****
TUNERCON : 198.000      OK
DRIVE    : DVD-RW DVR-L11X  OK
           1.00          OK

HDD INT  : WDC WD1600AAJS-9  160
HDD USE  :                   160
DEVICE   : E2R-FE          FLASH : 64M
REGION  : 2                C : *****

Input CH : ** ch
Freq Diff : Low 1
AGC Volt  : **** mV
    
```

* The RF signal status can be obtained from the input frequency deviation information and the AGC voltage.

Input CH : ** ch ← Input channel
 Freq Diff : Low 1 ← Input frequency difference *1)
 AGC Volt : **** mV ← AGC voltage *2)

*1) Frequency Difference (Freg Diff)

How much tuning is off is monitored, as shown below:

Input Frequency	Display	
Faraway	High 7	
High (within 200kHz)	High 1-5	
Just Tune	Center	
Low	within 200kHz	Low 1-5
	over 200kHz	Low 7

*2) AGC voltage (AGC Volt)

The gain controlled by the tuner is monitored to infer the input electric field intensity.
 (The accuracy of inference differs depending on the product.)

	Field Intensity	AGC Volt
Intense field area (Clear image)	70 dBμ or more	3100 mV or less
Less intense field area (Noise may be generated.)	50 dBμ or more 70 dBμ or less	3100 – 4400mV
Weak field area (Much noise. EPG/VPS/PDC sometimes cannot be obtained.)	30 dBμ or more 50 dBμ or less	4400 mV or more (It is unable to discriminate under the weak field area.)
Very weak field area (Image damaged. EPG/VPS/PDC cannot be obtained.)	30 dBμ or less	4400 mV or more (It is unable to discriminate.)

[Tips]

For good reception, the field intensity must be 50 dBμ or more (AGC Volt 4400 mV or less).
 For accurate measurement, use a field intensity meter.

- 5) Press “ESC”. (Returns to the original screen)

6-2-5. HDD Information for the HDD return sheet (Simplified measurement mode)

HDD Information

• How to start/terminate the diagnostic program

Use the remote control unit for servicing.

How to start: Press the following keys in this order; “ESC”, “CX”, “0”, and “1” keys: (refer to 6-2-15).

How to terminate: Press “ESC” key.

Do not perform other operations on the unit while HDD diagnosis is in progress.

Although the diagnostic program is designed to function independently from the unit’s functions, operations on the unit during a diagnosis may cause a malfunction.

The following status is recommended during diagnosis: All stop, no timer recording (including auto-recording)

A) Display the menu on the screen.

The menu shown below is displayed when the diagnostic program is started.

To enter each mode, press the corresponding key “1” – “4” on the remote control unit for servicing.

```

HDD CHECK MODE [1-4]

1 HDD Information
2 S.M.A.R.T Attribute Information
3 S.M.A.R.T DST
4 HDD R/W Check
    
```

Tests to be executed

- ① **HDD Information:**
Checks the HDD information.
- ② **S.M.A.R.T. DST:**
Executes a simplified test or a reading test for all data.
- ③ **HDD R/W Check:**
Executes a writing/reading test for all data.
All data on the HDD will be erased if this test is executed.

Note: “2. S.M.A.R.T. Attribute...” is not used.

B) Check the HDD information.

Press “1” key on the remote control unit for servicing.

Check the following data:

Model: Is the correct model name of the HDD displayed ?

Recog. No: Is a positive value displayed ?

SMART threshold: Is “not exceeded” displayed ?

```

HDD Information<SND_MS>[clear]
Cylinders : 0x3FFF Heads: 0x0010
Sec/Track : 0x003F
A → Model : Maxtor 4R080L0
D → Firmware : RAMC1TU0
SN : R22RRL2SE
E → Major No : ATA/ATAPI-7
Life Time : 7h 18m 45s
B → Recog. No : 1
C → SMART threshold : not exceeded
    
```

Detailed description

- ① **Model:**
For the correct model name, refer to the display of the unit.
- ② **Recog No:**
Positive value : The HDD has been recognized.
Negative value : The HDD has not been recognized.
- ③ **SMART threshold:**
exceeded : The has come near the end of its service life.
not exceeded : The HDD has not reached the end of its service life.
- ④ Check HDD SN.

To return to the menu screen, press “Clear” key.

C) How to check the HDD return sheet.

Symptom *** ⇒ Enter a symptom.**

- ① MODEL :***** not recognize or recognize ⇒ Enter a model name. Refer to “A” of the above screen.
When the model name is recognized, circle “recognize”.
- ② RECOG NO:Positive or Negative ⇒ Check whether “Recog No” is positive or negative.
Refer to “B” of the above screen.
- ③ SMART threshold: exceeded or not exceeded ⇒ Check whether “SMART threshold” is “exceeded” or “not exceeded”.
Refer to “C” of the above screen.
Note: If the HDD model name and serial number cannot be read, check the HDD label.
- ④ Check HDD SN:***** not recognize or recognize ⇒ Enter the HDD SN. Refer to “D” of the above screen.
Check whether the HDD SN is recognized.
- ⑤ HDD Life Time: ***h** m ** s ⇒ Enter the Life Time. Refer to “E” of the above screen.
Note: If the HDD life time is not found, check it on page 6-7 of Chapter 6, “SERVICE MODE”.
- ⑥ HDD Status: # / ! / Blank / No Model Name ⇒ Check “HDD Status”. Refer to “SERVICE NOTE”, page 1-3.
- ⑦ FL Display E01 / E02 / No Problem ⇒ Check “FL Display”.
- ⑧ Recording Error history :***** ⇒ Refer to “SERVICE MODE”, page 6-9.
- ⑨ ATA/ATAPI History ERR :***** ⇒ Refer to “SERVICE MODE”, page 6-10.

HDD Information (Simplified measurement mode)

- 1) Turn on the main power.
- 2) Press “ESC”.
- 3) Press “DISP”.
- 4) Press “DIG/ANA” three times.

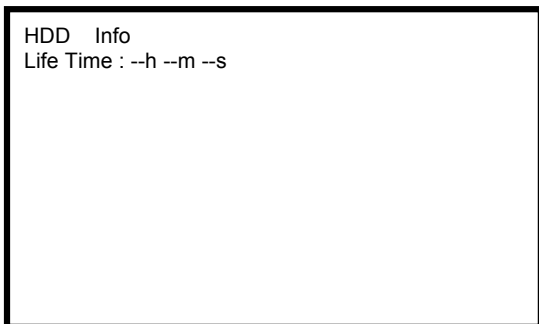

* Checks the HDD power-on time.

[Tips]

• How the cumulative HDD-on time data is processed in memory

Storage place:
FLASH ROM

Timing for referring to the cumulative HDD-on time data:

If the power attempts to turn on but fails, the unit refers to the FLASH ROM.

Timing for updating the cumulative HDD-on time data:

While the HDD is on, the cumulative HDD-on time data in the RAM is updated every 3 seconds, and the data is stored in the Backup SRAM every update. When the power is turned off, the data is stored in the FLASH ROM.

• How to clear the cumulative HDD-on time data

FLASH ROM:

When the HDD Identification Setting is configured, the cumulative HDD-on time data is automatically cleared.

The HDD Identification Setting is automatically configured when the CPRM setting is configured on the CPRM setting screen.

(To display the CPRM setting screen, press the “ESC” key, then the “STEREO” key.)

Note: The cumulative HDD-on time data is not cleared when resetting to default values.

The cumulative HDD-on time data is not cleared when the system-control computer software is downloaded.

- 5) Press “ESC”. (Returns to the original screen)

6-2-6. Cautions for handling the HDD

(1) Cautions for handling the HDD

- The HDD is very sensitive to shocks and vibrations. Care must be taken especially during operation (when the power is on).
- The HDD is very sensitive to electrostatic charges.
- Rapid change in temperature or humidity may cause deterioration of the HDD.

Note: After receiving damage caused by any above-mentioned factors, the HDD may operate normally for dozens or hundreds of hours, but then suddenly crash. If you are certain you have damaged a new repair part (HDD) while making repairs, do not use the part.

Reference: Main specifications for damage to the HDD

	During operation	During nonoperation
Shock G (acceleration)	Approx. 20 G or more	Approx. 200 G or more
Temperature change	15 °C/hour or more	
Moisture change	20%/hour or more	

← The HDD is about 10 times as sensitive to shock during operation compared to nonoperation.

Reference: Estimated value of falling distance vs. shock (G) when the HDD is dropped without protection

Falling distance \ Landing surface	Granite surface	Concrete floor	Synthetic-resin-coated table	Antistatic sponge
0.5 inch / 12.7 mm	387	217	200	26
1.0 inch / 25.4 mm	595	457	310	37
2.0 inch / 50.8 mm	1133	600	680	70
4.0 inch / 101.6 mm	1795	1040	1050	267

(2) Cautions for handling and examples of dangerous handling for the product that the HDD is mounted on or the HDD repair part

[Cautions for handling the product that the HDD is mounted on]

- The HDD is always in operation while the unit is turned on. Do NOT to apply shock to the unit.

Examples of dangerous handling: while the power is on

- Bumping the case
- Dropping an object, such as a small screwdriver or remote control unit, onto the case or bumping an object against the cabinet
- Physically dragging the unit
- Stacking another product on the unit

Note: Do NOT to apply shock, such as bumping or hitting a screwdriver against the HDD, during diagnosis with the case open.

Examples of dangerous handling: while the power is off

- Applying strong shock, although the HDD is more resistant to shock when the power is off
- Dropping the unit from a height of several centimeters, or lifting one side of the unit and letting it drop
- Do NOT move the unit immediately after the power is turned off. Wait at least 30 seconds after the indication on the FL display changes from POWER OFF to the clock indication before moving the unit.

If the AC power cable is accidentally disconnected before turning the unit off, wait at least for one minute before moving the unit.

In this case, damage to the HDD caused by sudden shutoff may be small because the emergency relief mechanism is activated.

However, if sudden shutoff occurs during recording or playback, recorded data may be damaged. Be sure to check the operations.

[Caution for handling the HDD repair part]

1. Handle the HDD in a safe environment:

- Handle the HDD over an antistatic pad that can also absorb shock.
- Wear wrist bands to prevent electrostatic charges generated in your body from affecting the HDD.

2. Observe the following rules when handling the HDD:

- Handle one HDD at a time. Do NOT hold several HDDs at the same time.
- Grip the HDD on both sides so that you do not touch its terminals or circuit boards.
- Do NOT stack one HDD onto another HDD (even if the HDDs are protected by antistatic bags).
- Do NOT bump the HDDs against one another.
- Do NOT bump any tool, such as a screwdriver, or other hard object against the HDD.
- When a repair part (HDD) is transported and there is a large temperature difference between the outside and inside temperature, leave the HDD in its package for about half a day after it is moved inside to gradually cool or warm it to room temperature before packing.

6-2-7. HDD Error Logging

Use the following operations to display “Recording Error History”.
Press “ESC”, “DSP”, and “4” keys, followed by “DIG/ANA” key three times.

Recording Error History Display		
07-01-01	00:00:00	HDD Destroy
07-01-01	00:00:00	Mech No Res
07-01-01	00:00:00	Mech No Res

* The error display appears in the underlined location.

Recording Error History Display

Error related to HDD	
Error Message	Description
Buf over flow	Overflow of the Stream Buffer
ESFSYS CORUPT	easyfsys error
ESFSYS INIT	easyfsys initializing
HDD Aging NG	HDD Aging Command failed
HDD DEF DONE	HDD defrag finished
HDD DEF ERR	HDD defrag error
HDD DEL OC TT	Title imported to the HDD deleted
HDD DEL PL	Dubbing list deleted by HDD recovery
HDD DEL TT	Title deleted by HDD recovery
HDD Destroy	HDD is not recognized on the bus
HDD INFO BAD	Incorrect HDD Management Data
HDD Initialize	HDD initialized
HDD IRRG POFF	Abnormal power off
HDD MBR NG	Incorrect MBR data
HDD SIG NG	Incorrect HDD Management Data Magic
HDD SMART NG	Incorrect HDD SMART
HDD unauthor	Incorrect HDD serial No.
HDD Zero WR	Incorrect MBR data
HDD Reset Done	HDD Reset executed
irr astion	Incorrect action
Mech No Res	No response from the mechanical-control computer
STATUS NG	Abnormal status change
Task No Activ	Task has not been activated
TT Rec Over	Title recording time full

Note: Not only the HDD error history, but also the error recovery history are logged in “Recording Error History”.

6-2-8. ATA/ATAPI History - ERR

Use the following operations to display "ATA/ATAPI Error History".
 Press "ESC" key, followed by "DSP", "2", "DIG/ANA", and "FRM/TIM" key.

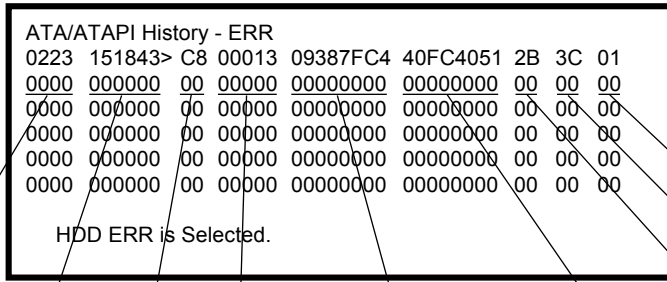

ATA/ATAPI ERR History display specification

Legend for error history display specification:

- A1 A2 A3 A4
- B1 B2 B3 B4 B5 B6
- C1 C2
- D1 D2 D3 D4 D5
- E1 E2 E3 E4 E5 E6 E7 E8
- F1 F2 F3 F4 F5 F6 F7 F8
- G1 G2
- H1 H2
- I1 I2

Command Error register Status register Command

28-bit command		48-bit command		
A1	error datecode	A1	error datecode	EXECUTE DEVICE DIAGNOSTIC 90
A2	error datecode	A2	error datecode	FLUSH CACHE E7
A3	error datecode	A3	error datecode	IDENTIFY DEVICE EC
A4	error datecode	A4	error datecode	IDLE E3
B1	error time	B1	error time	READ DMA C8
B2	error time	B2	error time	READ DMA EXT 25
B3	error time	B3	error time	SET FEATURES EF
B4	error time	B4	error time	SMART B0
B5	error time	B5	error time	STANDBY E2
B6	error time	B6	error time	STANDBY IMMEDIATE E0
C1 C2	command	C1 C2	command	WRITE DMA CA
D1, D2, D3, D4, D5	TBD	D1, D2, D3, D4, D5	TBD	WRITE DMA EXT 35
E1	0	E1, E2	LBA Low	IDLE IMMEDIATE E1
E2	Device register	E3, E4	LBA High	
E3, E4	LBA High	E5, E6	LBA Mid	Read Verify EXT 42
E5, E6	LBA Mid	E7, E8	LBA Low	Only use performance and factory check
E7, E8	LBA Low	F1 F2	Error	Note: **EXT: 48bit command
F1 F2	Error	F3, F4	Sector Count	
F3, F4	Sector Count	F5	Device	
F5	Device	F6	0	
F6	0	F7 F8	Status	
F7, F8	Status	G1, G2, H1, H2, I1, I2	TBD	
G1, G2, H1, H2, I1, I2	TBD			

6-2-9. How to confirm HDD Access Flow

Use the following operations to display "ATA/ATAPI History - All".
 Press "ESC" key, followed by "DSP", "2", and "FRM/TIM" key.
 Confirm whether the result is OK or NG in the screen below. If it is NG, check the error in the command table to the lower right.

OK

2B 3540C6E16F6000

Command

No problem

NG

2B C849387FC4FC00

23A00

Command

READ DMA Error Occurred (NG)

Command

- EXECUTE DEVICE DIAGNOSTIC 90
- FLUSH CACHE E7
- IDENTIFY DEVICE EC
- IDLE E3
- READ DMA C8
- READ DMA EXT 25
- SET FEATURES EF
- SMART B0
- STANDBY E2
- STANDBY IMMEDIATE E0
- WRITE DMA CA
- WRITE DMA EXT 35
- IDLE IMMEDIATE E1

6-2-10. ATA/ATAPI Debugging Screen (Second Screen) and LD Deterioration Judgment (for writer)

1. Writer maintenance information of ATA/ATAPI DEBUG OSD (Subscreen3)

- 1) Turn of the main power ON.
- 2) On the screen after exiting all menu screens, press “ESC” on the service remote controller.
- 3) Press “DISP”.
- 4) Press “2”.

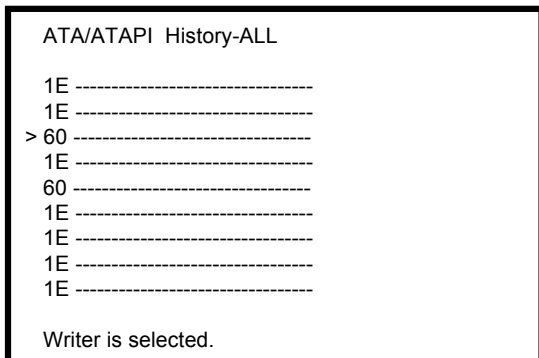

- * Simplified judgment method of optical pickup quality
 1. Stains on pickup lens
 2. Deterioration of CD-R/DVD-RW laser diode

* Screens are switched when “DIG/ANA” is pressed two times or three times to select the desired menu. Press “SEARCH” to start measurement.

Update the display by pressing the “SEARCH” key while subscreen 3 is displayed.

①	ATA / ATAPI	Writer MaintenanceInfo
	Power ON	00 00 00 0000 00000000
	0102 : 56	01 00 00 0000 00000000
	DVD	02 00 00 0000 00000000
②	R0053 : 48	03 00 00 0000 00000000
③	W0022 : 16	04 00 00 0000 00000000
	CD	05 00 00 0000 00000000
④	R0034 : 04	06 00 00 0000 00000000
⑤	W0000 : 00	07 00 00 0000 00000000
		00-00

Error log for the Writer
(Not for Service)

- ① Power-on time/cumulative power-on time
- ② Duration of emission of the laser diode (LD) for DVD-R/DVD while reading
- ③ Duration of emission of the LD for DVD-W/DVD while writing
- ④ Duration of emission of the LD for CD-R/CD while reading
- ⑤ Duration of emission of the LD for CD-W/CD while writing
(This function is not used for this model.)

- ② If the total hours of duration of emission of the laser diode (LD) for DVDs while reading ② and that of emission of the LD for DVDs while writing ③ exceed 4,700 hours, the LDs may be degraded.
Perform an LD degradation judgment, using subscreen 4.

[Tips]

MTTF hours for each LD

DVD : 4,700 hours

CD : 11,000 hours

The ATA/ATAPI Writer Maintenance Info is obtained each time the power is turned on. Thereafter, the data on the subscreen is updated each time the “SEARCH” key is pressed (the updating command is sent) while this subscreen is displayed. Care must be taken when updating this subscreen, because an undesired command is inserted if it is executed while recording, etc.

[Note on lighting time data for each LD]

Since data on lighting time of each laser diode (LD) are stored in the flash ROM on the MAIN Assy, after the MAIN Assy is replaced, the data will be cleared. However after the LOADER Assy is replaced, data on lighting time of each LD will be retained in the MAIN Assy. Therefore, before either the MAIN Assy or LOADER Assy is to be replaced, it is recommended that you write down the lighting time data.

- 5) Press “ESC”. (Returns to the original screen)

2. LD degradation judgment of ATA/ATAPI DEBUG OSD (Subscreen 4)

- 1) While the User Operation screen is being displayed, press “ESC” on the service remote controller.
- 2) Press “DISP” on the service remote controller.
- 3) Press “2” on the service remote controller.
- 4) Press “DIG/ANA” three times.

Note: For correct measurement of items ① to ④ indicated in the display below, leave the unit at room temperature (25°C) for a while before turning it on, and do not load a disc.

To update the value for each item, press the “SEARCH” key while subscreen 4 is displayed.

For details on each item and the conditions of updating the values, see table below.

ATA / ATAPI - LD Degrade			
①	→ CD :	0070 104%	OK
②	→ DVD :	0068 96%	OK
③	→ TMP :	00A3 41°C	
④	→ ADJ :	0067 26°C	
⑤	→ TLT :	FFD5	

Description of each item and conditions for updating data

No.	Item	Description	Conditions for updating by pressing the SEARCH key
①	CD	Degradation judgment of LD for CD. Regarded as NG when the value is 120% or higher (same standard as for the PC drive)	No disc inserted in the disc tray
②	DVD	Degradation judgment of LD for DVD. Regarded as NG when the value is 120% or higher (same standard as for the PC drive)	No disc inserted in the disc tray
③	TMP	Current temperature inside the Writer	No disc inserted in the disc tray
④	ADJ	Temperature (approx. 25°C) inside the Writer during adjustment	No disc inserted in the disc tray
⑤	TLT	Writer adjustment data for straight (non-HDD) model (FFFF is displayed when the writer is not adjusted.)	No condition

If the results of degradation of the LDs for CDs and DVDs are both NG, replace the drive.

- 5) Press “ESC”. (Returns to the original screen)

6-2-11. History of VR Recording-related Errors

- 1) Turn of the main power ON.
- 2) On the screen after exiting all menu screens, press “ESC” on the service remote controller.
- 3) Press “DISP”.
- 4) Press “4”.

```

RunFnc : --- Ecl : STDBY Rate : 21   VID : 1000
enVobu : ---- Rem Sec : ----   ChgAtr : ----
WorkSt : ---- EmgTyp : ----   ProtF : ----
Rec Err : ----   TrmStp : Normal
                LastRecMsg : PARAMCHG

LyrOrem : ----   LyrBndLSN : SglLayer
Drv Err : ----- ErrAdr : ---   Pause : ----
DscSt1 : ----- DscSt2 : ----- DscSt3 : -----
LastLSN : ----- NWA : -----   WrtSpd : -----
BrdNum : --- DV : --- RzNum : ---   Format : --- tvSys : PAL
RemMemo : ---- RMDn : ----   LstErr : ----
    
```

* Used for broadly dividing the poorly-reproducible trouble phenomena.

* Press “DIG/ANA” three times to browse the error log.

- 5) Press “ESC”. (Returns to the original screen)

Error Message Check Method

- 1) Turn of the main power ON.
- 2) On the screen after exiting all menu screens, press “ESC” on the service remote controller.
- 3) Press “DISP”.
- 4) Press “4”.
- 5) Press “DIG/ANA” 12 times. (Select the desired screen.)

```

RunFnc : --- Ecl : STDBY Rate : 21   VID : 1000
-----
-----
-----
-----
    
```

* Used for localizing the cause of trouble to an approximate area from the error message information.

Recording-related errors are displayed.



Press “DIG/ANA” three times on the above screen to select the desired screen.

```

① Recording Error History Display
01-06-01  20:05  30  No SysHdr IN
01-06-02  00:22  10  Write Error
    
```

Error message display screen

- ① There are two error-log screens, and up to 9 logs are displayed per screen.
(generation time [year-month-day, hour: minute: second], error data in simplified description.)

[Tips]

- The two error-log screens can be switched by pressing the “SPEED+” or “SPEED-” key.
- For details on error messages, see table “Description of VR-recording-related errors” (page 6-14 to 6-16).

- 6) Subscreen 5 to 11 (These subscreens are not for service use.)
- 7) Press “ESC”. (Returns to the original screen)

Description of VR-recording-related errors

Error Message Contents

Abbreviations

ECC : 4-byte Code for Error Correction
 UDF : Universal Disc Format
 PCA : Power Calibration Area
 OPC : Optical Power Control
 NWA : Next Writable Address
 VMG : Video Manager
 RMA : Recording Management Area
 MKB : Media Key Block
 TMP_VMGI : Temporary Video Manager Information
 Border : from Lead-in to Lead-out

MPEG Encoder-Related Errors

ERROR MESSAGE	DESCRIPTION
AVEnc Hang	AVEncoder failed
IN Encode*	Changes cannot be made in process of encoding
No SysHdr IN	System packet is not input periodically
Stm Start NG	Failure to start encoding (reasons not clear)
Stream NG	Inappropriate input stream data
Strm Start NG	Timeout waiting for system packet input at the beginning

Note: Any error message with "*" is displayed "RecErr: -----" on the Subscreen1 of the forth screen.

Drive System-Related Errors

ERROR MESSAGE	DESCRIPTION
Bdr Cls NG	Close Border failed
Bdr Opn NG	Open Border failed
BUF Overflow	Overflow of the Stream Buffer
CLS Rzon Fail	Video mode Close Rzone failure
Drive Hang	The Drive is hang up
Drv Err	General error of the Drive
Drv Hard Err	Abnoemality in the drive hardware or firmware
Drv Timeout	Timeout waiting for drive operation
Fail Repair	Repair failed
Format NG	Format failed
Mey Be V mode	Although TMP_VMGI is not written, it may be Video mode disc
Mech No Res	No response from the mechanical-control computer
MKB invalid	Media Key Block reading error
NWA Exhaust	Next Writable Address surpassed and impossible to use
OPC NG	Optical Power Control failed
PCA Full	Power Calibration Area has been used up.
Read Err	Reading failed, ECC (4 byte Code for Error Correction) failed, etc
Read Only Disc*	Because some data are invalid , data cannot be written
RMA Full	Recording Management Area has been used up
Rzn Cls NG	Close Rzone failed
Rzn Rpr NG	Repair Rzone failed
Rzn Rsv NG	Reserve RZone failed
TMP-VMG WrErr	Video mode TMP VMGI Write Error
VTSI_B Wr Err	Video mode VTSI BUP Write Error
VTSI_B2 Wr Err	Video mode VTSI BUP Write Error (After Layer Change)
VTSI Wr Err	Video mod VTSI Write Error
VTSI2 Wr Err	Video mod VTSI Write Error (After Layer Change)
Write Err	The Drive failed to write and could not be recovered
May Be PVR	May be +VR disc, but no RSAT
V Final fail	Abnormal process occurred when finalizing Video mode
DLVR trace NG	Close Rzone failed at dual layer disc

Dubbing-Related Errors

ERROR MESSAGE	DESCRIPTION
H2D CP SomeNG	Other NG HDD → DVD copy
Mem get NG	Video Mode Copy Memory has not been ensured
Strm TransfNG	Video Mode Copy Stream Transfer NG
Tracon Tm NG	Video Mode Copy Tracon transfer has not been completed
VC Cell Max	Maximum number for Video Mode Copy Cells exceeded
VC CopyCancel	Video Mode Copy Copy Cancel
VC FlushC NG	Video Mode Copy Flush Cache NG
VC HDD C Err	Obtaining Video Mode Copy HDD Cell information failed
VC HDD Inf NG	No information on Video Mode Copy HDD
VC HDD Info NG	Format failed
VC Idling NG	Video Mode Copy idling NG
VC Pck Anl NG	Analyzing Video Mode Copy Pack failed
VC Transf Stp	Video Mode Copy Transfer Stop
VC TSO BLK NG	Video Mode Copy TSOBlock transfer has not been completed
VC VOBUsizeE	Video Mode Copy VOBUsize NG
V Rsv RzoneNG	Video Mode Copy Reserve Rzone failed
V2H APP FL NG	VR→HDD APP FLG is OFF
V2H Aud Ch NG	VR→HDD Audio Channel NG
V2H Aud Md NG	VR→HDD Audio mode NG
V2H Aud Stm N	VR→HDD Audio Stream Number NG
V2H SRC Prot	VR→HDD Copy prohibited material
V2H Unknown	VR→HDD Other NG
V2H VOBUsizeE	VR→HDD Play back time of each VOBUsize is different
V2H V Reso NG	VR→HDD Video resolution NG
H2D CP NoSpec	HDD→DVD insufficient free space for copy
H2D TO HDDRD	HDD→DVD(VR) Timeout at HDD playing side
H2D TO SPRP	HDD→DVD(VR) Timeout at internal processing
H2D TO DVDWR	HDD→DVD(VR) Timeout at HDD recording side
C2H LOG (XXX)	HDD CAM→HDD operation log (XXX indicates process code.)
C2H NG (XXX)	HDD CAM→NG (XXX indicates process code.)

HDD-Related Errors

ERROR MESSAGE	DESCRIPTION
Do nothing	Do nothing for demand
ESFSYS CORUPT	easyfsys error
ESFSYS INIT	easyfsys initializing
HDD Buff High	High-level process executed for the HDD Buffer
HDD DEF DONE	HDD deflag finished
HDD DEF ERR	HDD deflag error
HDD Destroy	HDD is not recognized on bus
HDD INFO BAD	Inconsistent HDD Management Data
HDD Initialize	HDD initialized
HDD IRRG POFF	Abnormal Power off
HDD MBR NG	Inconsistent MBR data
HDDReset Done	HDD Reset executed
HDD ROMSUM NG	Rom-code check sum NG
HDD SIG NG	Inconsistent HDD Management Data magic
HDD SMART NG	Inappropriate HDD SMART
HDD Trans Err	DMA error in HDD copy transfer
HDD unauthor	Inconsistent HDD serial No
HDD Zero WR	MBR was written
Task No Activ	Task has not been activated
TT Rec Over	Title recording time full
HDD WRONG TGT	Invalid HDD target No is directed
extHDD Ignore	External HDD is dismounted
HDD PFile NG	Program file installed in HDD is NG
HDD DEL TT	Delete the title by HDD recovery
HDD DEL PT	Delete the dubbing list by HDD recovery
HDD Del OC TT	Delete the title moving on the way inside HDD

Other Errors

ERROR MESSAGE	DESCRIPTION
Abort	Cancellation
Already open	Extension file is already opened
BK BATT Down	Backup RAM Data has been erased
BK FSYS Dirty	Backup RAM Data has not been written on the File Sys
BUG	some Bugs
BusReset Done	Bus Reset has been executed
Cell Close NG	Cell Close NG
CPRM IC NG	Inappropriate CPRM IC
Dir Depth Err	Tree of Directory is too deep
Disc Full*	No further data can be written because the disc is full
DRAM CLR Err	Video Mode DRAM (Stream Buffer) Clear failure
DRAM NG	Abnormality in access to the Work DRAM
Drive Destroy	The Drive has crashed
EncModul Hang	Encoder routine is hung up
F Alrdy Exst	Extension file is already exist
File cancel	Extension file is canceled
FileNot Exist	Extension file is not exist
Format Excec	Formatting has been executed
Invalid Disc*	The disc cannot be recognized
Invalid Param*	Invalid parameter
Invalid TMVMG	Invalid TMP VMGI content
Invalid UDF*	Invalid UDF content
Invalid VMG*	Invalid VMG content
Invalid VTSI	VTSI information of +VR is unusual
Irr Action*	Incorrect action
MKB REVOKED	Error is gaining data
limit Over*	Standard maximum limit exceeded
No More Info*	No more space in the internal work-management area
No Permission*	No permission to write to the disc
No Video	No Video input (not locked)
Now busy*	In the process of the emergency processing
NV Pck DMA Er	Inappropriate NaviPack DMA
NV Pck MK Err	Error in creating NaviPack
Ourob Strm NG	Inappropriate Stream data to the Ouroboros input
Over Heat	Abnormal temperature
PARAM NO ACCP	Recording parameter is not matched
Process Over	Process is overfull
Protect Scr*	Source to be recorded is copy-protected
Rec Pause*	No operation permitted during recording pause
Relocation Do	VR-recording data was relocated
Repair Excec	Repairing has been executed
Something*	Undetermined error
SRAM NG	Abnormality in access to the backup Work SRAM
Status NG*	Abnormality in change of statuses

ERROR MESSAGE	DESCRIPTION
SW PVR	Switch to +VR playback process
SW Vpb mode*	Switching to video playback routine is required
SW Vrec mode*	Switching to video recording routine is required
Unmatch Stamp*	Impossible to modify because of nonmatching time stamp
VBR-SRAM NG	Abnormality in VBR SRAM
V Categ ID NG	Inappropriate category ID
V Cate Inf NG	Inappropriate category information
V Ext MAX Ovr	Count Max exceeded
V ExtToo Big	The extension file is too large
V Ext TY NG	Type NG
Virgin Disc	Virgin Disc
VOBU Info NG	Inappropriate VOB information
WaterMark Det	Watermark detected
WM Cracked	WM Cracked
Param Short	Editing Error (Clear A-B)
Invalid VRMI	Information of +VR is NG (VRMI)
Heap Mem NG	Failed acquire memory
Heap Mem RETY	Retry has occurred during acquisition of memory

No Error

ERROR MESSAGE	DESCRIPTION
Non Err*	Normal

6-2-12. DV Service Mode

1. DV debug

- 1) Turn of the main power ON.
- 2) On the screen after exiting all menu screens, press “ESC” on the service remote controller.
- 3) Press “DISP”.
- 4) Press “3”.

```

① → (DV/1394) Init : NG AV : 02 DV : 01
② → [Recorder] GUID : 0000000000000000 IRM
③ → iPCR : C03F0000
④ → [DV] GUID : 0080880303480E96
⑤ → VN : VICTOR MN : GR-D50K
⑥ → TM : C3 TS : 75 CT : 32 WP : 01 PS : FF OS : 00
⑦ → CA : A000002020 MD : VTR
⑧ → [DVdecode : Yes] LineSys : 625-50
⑨ → TC : 00h20m35s RD : 02/02/05 RT : 10h34m50s
⑩ → ASPECT : 4 : 3 CGMS : 000000 APSTB : 00 DEC : 525-60
⑪ → SF : 32KHz QU : 12bit AMODE : 4) Stereo
    
```

* Used when an error exists in connection with the DV equipment.

Boldface alphanumerics : Fixed indications
 Nonboldface alphanumerics : Variable indications

No.	Item	Description	Remarks
1	InitDV	Whether the initialization of UPD72893B (1394 LINK and DV codec IC) has been completed (OK) or not (NG).	If NG is displayed, it is considered the communication failure to UPD72893B.
	InitVE	Whether the initialization of ADV7172 (Video Encoder for DV specific) has been completed (OK) or not (NG).	If NG is displayed, it is considered the communication failure to ADV7172.
	AV	Number of AV devices recognizing connection	Identification number of AV devices including D-VHS, Digital Tuner, etc other than DV devices.
	DV	Number of DV devices recognizing connection	If the number does not become 01 even if a DV device is connected, identification of that device fails.
2	GUID	GUID set in ConfigROM of the unit.	GUID : Global Unique ID (Specific ID for DV devices) If the unit is ROOT (IRM), IRM is displayed at the side position of GUID display .
③	iPCR	iPCR value of the unit	
	oPCR	oPCR value of the unit	
④	GUID	GUID set in ConfigROM of the connected DV device.	Data are displayed only if one DV device is identified. If the connected DV device is ROOT (IRM), IRM is displayed at the side position of GUID display.
⑤	VN	Vendor name set in ConfigROM of the connected DV device.	Data are displayed only if one DV device is identified. (Depending on the device, the vendor name may not be set in ConfigROM.)
	MN	Model name set in ConfigROM of the connected DV device.	Data are displayed only if one DV device is identified. (Depending on the device, the model name may not be set in ConfigROM.)
⑥	TM	Transport Mode data obtained from the DV device.	Data are displayed only if one DV device is identified.
	TS	Transport State data obtained from the DV device.	
	CT	Cassette Type data obtained from the DV device.	
	WP	Write-protection data obtained from the DV device.	
	PS	Power-state data obtained from the DV device.	
	OS	Output signal mode data obtained from the DV device.	
⑦	CA	Connect AV data obtained from the DV device.	Data are displayed only if one DV device is identified.
	CV	Camera/Vtr mode data obtained from the DV device.	
	MD	DV device mode	Camera or VTR is displayed only if one DV device is identified.
⑧	[DVdecode: XXX]	Whether Yes (in the process of requesting DV input) or No is indicated in XXX.	Normally, Yes is indicated only when CH is set to DV.
	LineSys	Input Line System setting	
⑨	TC	Time-code data of the DVdecode Stream, or response data of the Time Code command	Stream time-code data are obtained when the tape is played in forward direction. Otherwise, time-code data are obtained through an AV/C command.
	RD	Rec Date of DVdecode Stream	
	RT	Rec Time of DVdecode Stream	
⑩	ASPECT	Aspect Ratio of DVdecode Stream	
	CGMS	CGMS of DVdecode Stream (from left to right, CGMS data of bits 5-4: Audio ch 2, bits 3-2: Audio ch 1, and bits 1-0: Video)	*CGMS (Copy Generation Management System): The two-digit codes added to broadcast programs represent the following: 00: Copy freely, 10: Once copy, 11 : Never copy
	APSTB	APS trigger bit of DV decode stream	
	DEC	With/without DVdecode stream input	With input: Signal type (525-60, 625-50, 1125-60, 1250-50, or Invalid) is indicated, Without input: “No” is indicated.
⑪	SF	Sampling Frequency of DVdecode Stream	If SF is 44 kHz, it is considered that 44.1-kHz audio is input, and sound is muted on the unit.
	QU	QUANTIZATION of DVdecode Stream	
	AMODE	AUDIO MODE of DVdecode Stream	

- 5) Press “ESC”. (Returns to the original screen)

2. Simple Diagnosis of DV

Symptoms	Location in the Debug Screen	Items to be Checked, and Conditions	Possible causes
No operation for DV input	DV①	Check the initDV indication: OK: Initialization of DV related LSI (IC102, IC108) appropriately completed. NG: Initialization of DV related LSI (IC102, IC108) has not been completed properly. Defective communication with DV related LSI (IC102, IC108) and Host u-com. (IC1001)	Defective IC102 (1394Link & DVcodec)/ IC108 (1394PHY), improper connection between IC102 / IC108, defective soldering, defective power supply, etc.
	DV②	Check the number of DV devices when one DV device is connected to the recorder: 01 : The connected DV device is correctly identified. Other than 01 : The connected DV device is not correctly identified.	Defective DV terminals, improper connection of the DV-terminal board, defective IC108 (1394PHY), defective cables, an IEEE 1394 device other than the DV device connected.
No picture nor sound for DV input	DV③	Check of DV decoding when the recorder channel is set to DV: Yes : The recorder is in the process of a DV input operation. No : The recorder is not executing a DV input operation.	Defective IC102 (1394Link & DVcodec), defective soldering, defective power supply, etc.
	DV④	Check DEC: 525-60 : An NTSC DV signal is input from the DV device. 625-50 : A PAL DV signal is input from the DV device. No : No DV signal is input from the DV device.	Defective DV terminals, improper connection of the DV-terminal board, defective source device defective IC102 (1394Link & DVcodec), IC108 (1394PHY) Note: As to a model having the Input Line System setting, if the setting and the actual input signal system do not match, no picture appears.
DV input recording impossible	DV⑤	Check CGMS:	Recording cannot be performed for a copy-protected source.
No sound for DV input	DV⑥	Check SF: 32 kHz: An audio signal with 32-kHz sampling frequency is being input. 48 kHz: An audio signal with 48-kHz sampling frequency is being input. 44 kHz: An audio signal with 44.1-kHz sampling frequency is being input.	An audio signal with 44.1-kHz sampling frequency is muted.
	DV⑦	Check the initVE indication: OK: Initialization of DV specific VideoEncoder (IC101) appropriately completed. NG: Defective communication with DV specific VideoEncoder (IC101) and HOST u-com (IC1001). Initialization of DV specific VideoEncoder (IC101) has not been completed properly.	Defective IC101 (DV specific VideoEncoder), defective soldering, defective power supply, etc.

6-2-13. EPG Service Mode

1. Summary screen

- 1) Turn of the main power ON.
- 2) On the screen after exiting all menu screens, press “ESC” on the service remote controller.
- 3) Press “DISP”.
- 4) Press “7”.

```

0          1          2          3          4
01234567890123456789012345678901234567
00 (EPG EURO)
01 Next Data Download Time : 14:00
02     Duration           : 01h30m
03 Gemstar Data Fail Count : 00
04
05
06
07 EPG Data Receive Err Summary
08 Data Start END MD CH RcvPkt TotalErr
09 03/31 13:00 13:30 DL 03 001853 000000
10 03/31 09:00 11:00 DL 03 001192 000000
11 03/31 08:00 08:05 HS -- 000654 000000
12 03/31 00:00 00:00      000000 000000
13 03/31 00:00 00:00      000000 000000
14 03/31 00:00 00:00      000000 000000

```

* Used when the EPG data cannot be acquired.

* The detailed screen appears every time when “DIG/ANA” is pressed.

Lines 01-02	The next download starting time for the EPG data is displayed. Next Data Download Time: Starting time Duration: Duration required for acquiring the EPG data
Lines 03	The Gemstar EPG data cannot be found. Number times of Host Scan and Schedule Download, DT models only (Always 00 except DT model)
Lines 09-14	The 6 latest error logs when EPG data were received are displayed, with the latest one at the top.
	Data : Month/day when reception started
	Start : Time when reception started
	End : Time when reception ended
	MD : Method for acquiring the EPG data (HS: Host scanning process, DL:Downloading process of the EPG data)
	CH : Data-receiving channel
	RcvPkt : Total number of received packages. A number 999,999 or greater is displayed as “999999”.
	Total Err : Total errors during reception. The sum of Hamming Err, Trans Err InvLine Err numbers indicated on the Detail screen. A number 999,999 or greater is displayed as “999999”.

[Tips]

In a case where only “HS” is displayed in the MD column of the logs, the host channel has not been found.
It is necessary to check the country and postal-code settings in the user settings.

- 5) Press “ESC”. (Returns to the original screen)

2. Detail screens

- 1) Press the “DIG/ANA” key while the Summary screen is being displayed. (Refer to page 6-19)
- 2) Each time the “DIG/ANA” key is pressed, the Detail screen scrolls maximum six-Detail screens (1 to 6).
Each Detail screen of 1 to 6 corresponds to the EPG reception error logs from the top of the Summary screen.

0 1 2 3 4
012345678901234567890123456789012345678901234567

```

00 (EPG EURO)
01 EPG Data Receive Err Details - 1
02
03 Data : 03/31
04 Start Time : 13:00   END Time  : 13:30
05 Host CH   : 03      P-ON Kind : Download
06
07 Data Receive Info   Total Err : 000000
08 Pkt Rcv Num : 001853 Pkt Snd Num : 001853
09 Inv Line Err : 000000
10 Slice Cont : Auto   EQ : OFF   LV : -h
11
12 Temporary Buffer Information
13 Pool Num   : 000000   Max Store : 000000
14 Discard Pkt : 000000
    
```

Line	Display item	Description	Remarks
Line 01	EPG Data Receive Err Details-X	The rightmost figure represents the number of the current detail screen. This number corresponds to the order of the EPG reception error log from the top.	
Lines 03-05, Reception conditions	Data Start Time END Time Host CH P-ON Kind	: Month/day when reception started : Time when reception started : Time when reception ended : Data-receiving channel : Methods for acquiring the EPG data (host scanning and downloaing)	Only during initialization, host scanning is automatically executed to find the host broadcast.
Lines 07-10, details on errors during reception	Total Err	: Total numbers of errors during reception. The total number of Hamming Err, Trans Err and InvLine Err indicated on the Detail screen. A number 999,999 or greater is displayed as “999999”.	Total Errors: If the total number of errors reaches two digits or greater, it is likely that EPG data acquisition failed. Display subscreen 1 of the first screen and check the electric field intensity from the AGC level.
	Pkt Rcv Num Pkt Snd Num	: Total number of received packages. A number 999,999 or greater is displayed as “999999”. : Total number of packages that were sent to the application program among all the received packages. A number 999,999 or greater is displayed as “999999”.	If the total numbr of received packages is 0, it is likely that the country and postal-code settings are wrong.
	InvLine Err	: Total number of errors that were generated by receiving data from invalid lines. A number 999,999 or greater is displayed as “999999”.	
	Slice Cont	: Slice level control Auto-Tu Con, Manual - Syscon.	
	EQ	: Equalizer setting (ON, OFF)	
	LV	: Slice level (10-30 hex) (Only when the slice Cont is Manual.)	

Note: The data on lines 12-14 are for software development, not for service use.

- 5) Press “ESC”. (Returns to the original screen)

6-2-14. Aging Mode

1. Aging for the DVD-RW/DVD-R

- 1) Turn of the main power ON.
- 2) Press the “DVD” key to switch to DVD.
- 3) Load a recordable disc.
- 4) Select the input function of a recordable source.
- 5) After disc detection is confirmed, exit all menu screens.
- 6) Press “ESC” on the service remote controller.
- 7) Press “REP.B” on the service remote controller.
- 8) Press “PLAY” to enter the Aging mode.

If symptoms regarding recording/playback of discs and/or the HDD that your customer claimed are difficult to reproduce, they can be reproduced with a long-time test in Aging mode.

- Note:**
- When aging for the DVD-RW/+RW/-RAM and HDD is executed, a recorded data on them will be erased.
 - Commands from the remote control unit are accepted during Aging mode.
 - If Aging mode is quit using the “ESC” key, indications on the FL display will return to normal display.
 - Cancel timer settings before entering Aging mode.
 - Set the recording rate beforehand. It cannot be changed during Aging mode.

Aging for the DVD-RW/+RW/-RAM	Aging for the DVD-R/+R
<p>During Aging mode, the following operations are repeated in the order shown below.</p> <ol style="list-style-type: none"> ① The tray opens. ② The tray closes. ③ Initialization ④ Recording for 60 minutes ⑤ Playback for 45 minutes <p><DVD-RW> The initialization process in step 3 follows the setting specified in “Setting of the main unit--Recording--Auto initialization of a DVD-RW”.</p> <p><DVD+RW> The initialization process in step 3 is the same as that described in “Disc setting--Initialization--Initialization of a DVD+RW”.</p> <p><DVD-RAM> In the initialization process in step 3, physical formatting is performed, if required.</p> <p>During Aging, the number of loops is indicated on the FL display, as shown below. [AGING 0001]</p> <p>If an error is generated, the aging operation stops. Note: Indications on the FL display are retained, and this information is also retained as an OSD.</p>	<p>During Aging mode, the following operations are repeated in the order shown below.</p> <ol style="list-style-type: none"> ① The tray opens. ② The tray closes. ③ Recording for 1 minute ④ Recording pause for 6 minutes ⑤ Recording stops. ⑥ Playback for 1 minute ⑦ Playback pause for 6 minutes ⑧ Playback stops. <p>Note: A continuous test of the above operations is possible for approximately 23 hours.</p> <p>After ② the tray closes, disc detection is performed, <DVD-R> In step 2, if the disc is judged to have recorded up to 99 titles, the operation stops at that point. <DVD+R> If the disc is judged to have recorded up to 49 titles, the operation stops at that point. On the FL display, the number of loops is retained. On the OSD display, the error indication is retained.</p> <p>During Aging, the number of loops is indicated on the FL display, as shown below. [AGING 0001]</p> <p>If an error is generated, the aging operation stops. Note: Indications on the FL display are retained, and this information is also retained as an OSD.</p> <p>Note: Recording time depends on the recording rate set. For example, if the recording rate is MN32, only up to 60 titles can be registered. Check the setting for recording rate before performing aging.</p>

- 9) Press the “ESC” key on the service remote controller to quit Aging mode and return to Normal mode.

- Note:**
- If during recording: Recording is stopped. (aging for ±RW/-RAM only)
 - If during playback: Playback is paused.
 - If during initialization: The unit stops after initialization is finished.
 - If the tray is being opened/closed: The unit stops after the tray is opened/closed.

2. Aging for the HDD

Caution: Take caution as the all recorded data of HDD is deleted.

- 1) Turn of the main power ON.
- 2) Press the “HDD” key to switch to HDD.
- 3) Press “ESC” on the service remote controller.
- 4) Press “REP.B” on the service remote controller.
- 5) Press “PLAY” to the Aging mode.

During Aging mode, the following operations are repeated in the order shown below.

- ① Erasure of all the memory data from the HDD
- ② Recording for 60 minutes
- ③ Playback for 60 minutes

[Tips]

During Aging, the number of loops is indicated on the FL display, as shown below.

[AGING 0001]

If an error is generated, the aging operation stops.

Note: Indications on the FL display are retained, and this information is also retained as an OSD.

- 6) Press the “ESC” key on the service remote controller to quit Aging mode and return to Normal mode.

Note: • If during recording: Recording is stopped.

• If during playback: Playback is paused.

• If during erasure of all memory data from the HDD, the unit stops after all memory data have been erased.

6-2-15. HDD Check Mode

- 1) Turn of the main power ON.
- 2) On the screen after exiting all menu screens, press “ESC” on the service remote controller.
- 3) Press “CX”.
- 4) Press “0”.
- 5) Press “1”.

```
HDD CHECK MODE

1 HDD Information [----]
2 S.M.A.R.T. Attribute Information
3 S.M.A.R.T. DST
4 HDD R/W Check

###HDD[INT] is selected ###change[SCAN FWD]
```

* Used to check if the HDD has an error or not.

* Press the number of the item you want to check.

- 6) Press “ESC”. (Returns to the original screen)

6-3. Setup Related Menu

6-3-1. Firmware Downloading

In case of any event as described below, be sure to download the software using the Version Upgrade CD Disc by following the Software Download Method shown below.

1. When engine (RD board or drive) is replaced, or when the AV board is replaced.
2. When HDD is replaced.
3. When the message “NG” is displayed on the Version Information in the Service Mode.

Software Download Method

- 1) Eject the tray.
- 2) Place the Version Upgrade disc on the tray.
- 3) Press “Rec Stop” and “EJECT” key at the same time to start version upgrade.

6-3-2. Area-Specific Channel Setting

When the following trouble symptom is displayed, set the broadcast reception channels as described below.

- When flickering is visible as if horizontal synchronization or vertical synchronization is lost on the broadcast reception screen.

[Entry]

Entry from the normal operating mode <Record/Play, Stop>

- 1) Turn of the main power ON.
- 2) Press “ESC” on the service remote controller.
- 3) Press “CHP/TIM”.

Setting screen

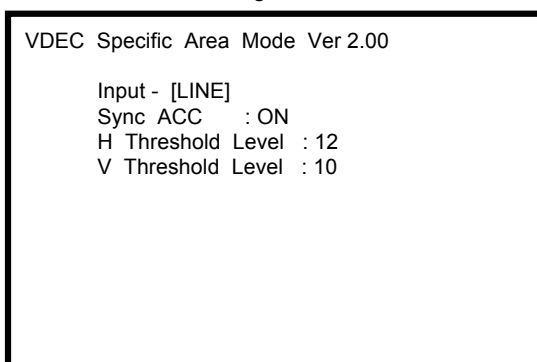

- 4) Press “ESC”. (Returns to the original screen)

[Entry from the individual setting mode]

- 1) Upon completion of the above operation, press “DIG/ANA”.

Setting screen

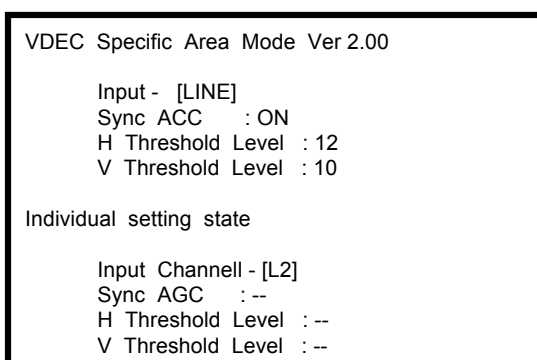

- 2) Press “ESC”. (Returns to the original screen)

6-3-3. OSD Filter Setting (Subscreen 4)

When the following trouble symptom occurs, correct it by setting the OSD filter as described below.

- Characters on the OSD screen flicker depending on the monitor connected.

[Entry]

- 1) Turn of the main power ON.
- 2) Press “ESC” on the service remote controller.
- 3) Press “DISP”.
- 4) Press “DIG/ANA” four times.

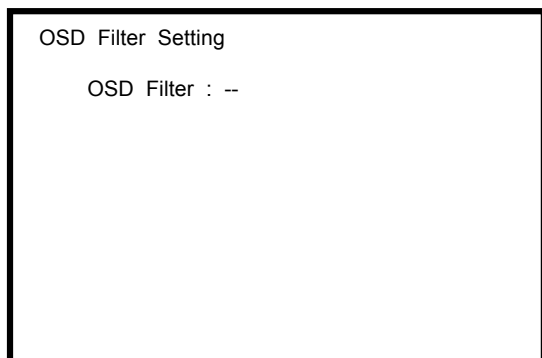

- 5) Press “ESC”. (Returns to the original screen)

[Tips]

As the setting value becomes greater, jitter is reduced on a CRT display. However, as lines for characters appear thick, complex characters may become difficult to read. On the contrary, as the setting value becomes smaller, jitter increases on a CRT display. However, as lines for characters become sharper, complex characters become more legible.

Note1: A new setting becomes active as soon as it is made. As a new setting is stored in nonvolatile memory it will be retrieved when the unit is turned on the next time.

Note2: After the factory-preset values are downloaded, the setting value for the OSD Filter will be the default Value (4).

[Key operation of OSD Filter setting]

Key	Operation	Setting value	Remarks
“Rev x 3”, “SPEED+” “ x 3 Fwd”, “SPEED-”	Changing the setting value for the OSD Filter	0 – 4 (Default value: 4)	“Rev x 3”, “SPEED+” : The setting value increases by 1. “ x 3 Fwd”, “SPEED-” : The setting value decreases by 1.
“CLEAR”	The setting value is reset to default.	—	
“ESC”	To exit the OSD Filter Setting and clear the screen (Appears the tuner screen.)	—	—

SECTION 7 ADJUSTMENTS

7-1. Video System Adjustment

Preparing for Adjustment

1. Equipments

- Oscilloscope
- Reference Disk
 - HLX-507 (PAL single layer disc) J-6090-077-A
 - HLX-506 (PAL dual layer disc) J-6090-078-A

1. Video Output Level Check

<Purpose>

This check is made to satisfy the PAL signal standard. If it is adjusted incorrectly, brightness will be too bright or too dark.

Mode	PLAY
Signal	100% Color bars
Test point	Output (VIDEO) connector (terminated in 75Ω)
Instrument	Oscilloscope
Specification	1.0 V± 0.07 Vp-p

Check method:

- 1) Insert the PAL reference disc and play back the 100% color bars.
- 2) Confirm that the video level is 1.0 V±0.07 Vp-p.



Fig. 7-1

2. S-Video Output S-Y Check

<Purpose>

This check confirms that the S-video Y-signal output has the rated amplitude. If it adjusted incorrectly, the playback video signal will not be displayed corrected even when the S-video cable is connected.

Mode	PLAY
Signal	100% Color bars
Test point	S-VIDEO OUTPUT (S-Y) connector (terminated in 75Ω)
Instrument	Oscilloscope
Specification	1.0 V±0.07 Vp-p

Check method:

- 1) Insert the PAL reference disc and play back the 100% color bars.
- 2) Confirm that the video level is 1.0 V±0.07 Vp-p.



Fig. 7-2

3. S-Video Output S-C Check

<Purpose>

This check confirms that the S-video output S-C conforms to the PAL standard. If it adjusted incorrectly, the playback color will not be too dark or too thin.

Mode	PLAY
Signal	100% Color bars
Test point	S-VIDEO OUTPUT (S-C) connector (terminated in 75Ω)
Instrument	Oscilloscope
Specification	PAL: 300 mV±30 mVp-p

Check method:

- 1) Insert the PAL reference disc and play back the 100% color bars.
- 2) Confirm that the burst signal level is 300 mV±30 mVp-p.



Fig. 7-3

4. Component Video Output Y Check

<Purpose>

This check confirms that the component Y signal output has the rated amplitude. If this signal level is not correct, brightness of the video signal will not be too dark or too thin when the COMPONENT connector output signal is connected to a projector having COMPONENT input.

Mode	PLAY
Signal	100% Color bars
Test point	COMPONENT VIDEO OUT (Y) connector (terminated in 75Ω)
Instrument	Oscilloscope
Specification	1.0 V±0.07Vp-p

Check method:

Note 1: Do not set RGB OUT to ON.

Note 2: Do not connect the HDMI OUT.

- 1) Insert the PAL reference disc and play back the 100% color bars.
- 2) Confirm that the Y signal level is 1.0 V±0.07 Vp-p.



Fig. 7-4

5. Component Video Output B-Y (Pb) Check

<Purpose>

This check confirms that the B-Y signal of the component video conforms to the PAL standard. If this signal level is not correct, color of the video signal will have different color when the COMPONENT connector output signal is connected to a projector having COMPONENT input.

Mode	PLAY
Signal	100% Color bars
Test point	COMPONENT VIDEO OUT (Pb) connector (terminated in 75Ω)
Instrument	Oscilloscope
Specification	700 mV±50 mVp-p

Check method:

Note 1: Do not set RGB OUT to ON.

Note 2: Do not connect the HDMI OUT.

- 1) Insert the PAL reference disc and play back the 100% color bars.
- 2) Confirm that the burst signal level is 700 mV±50 mVp-p.

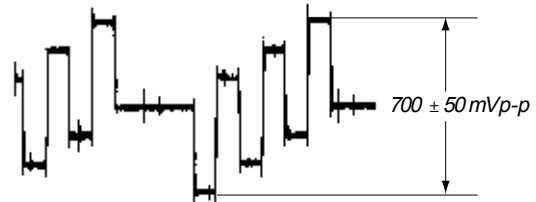

Fig. 7-5

6. Component Video Output R-Y (Pr) Check

<Purpose>

This check confirms that the R-Y signal of the component video conforms to the PAL standard. If this signal level is not correct, color of the video signal will have different color when the COMPONENT connector output signal is connected to a projector having COMPONENT input.

Mode	PLAY
Signal	100% Color bars
Test point	COMPONENT VIDEO OUT (Pr) connector (terminated in 75Ω)
Instrument	Oscilloscope
Specification	700 mV±50 mVp-p

Check method:

Note 1: Do not set RGB OUT to ON.

Note 2: Do not connect the HDMI OUT.

- 1) Insert the PAL reference disc and play back the 100% color bars.
- 2) Confirm that the burst signal level is 700 mV±50 mVp-p.

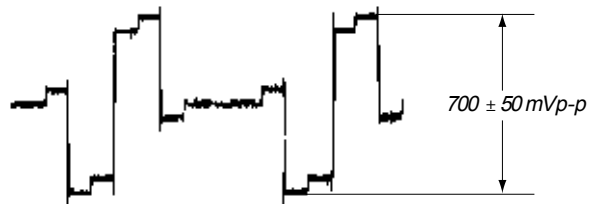

Fig. 7-6

7. Scart Video Output Level Check

<Purpose>

This check is made to satisfy the PAL signal standard, If it is adjusted incorrectly, brightness will be too bright or too dark.

Mode	PLAY
Signal	100% Color bars
Test point	Scart Video output connector pin-⑱ (terminated in 75Ω)
Instrument	Oscilloscope
Specification	1.0 V±0.07 Vp-p

Check method:

Note: SCART OUT should be set to “Video”.

- 1) Insert the PAL reference disc and play back the 100% color bars.
- 2) Confirm that the video level is 1.0 V±0.07 Vp-p.



Fig. 7-7

8. Scart Video Output S-Y Check

<Purpose>

This check confirms that the Scart Y-signal output has the rated amplitude. If it adjusted incorrectly, the playback video signal will not be displayed corrected even when the Scart cable is connected.

Mode	PLAY
Signal	100% Color bars
Test point	Scart Video output connector pin-⑱ (terminated in 75Ω)
Instrument	Oscilloscope
Specification	1.0 V±0.07 Vp-p

Check method:

Note: SCART OUT should be set to “S-Video”.

- 1) Insert the PAL reference disc and play back the 100% color bars.
- 2) Confirm that the video level is 1.0 V±0.07 Vp-p.

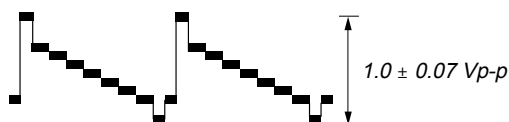

Fig. 7-8

9. Scart Video Output S-C Check

<Purpose>

This check confirms that the Scart output S-C conforms to the PAL standard. If it adjusted incorrectly, the playback color will not be too dark or too thin.

Mode	PLAY
Signal	100% Color bars
Test point	Scart Video output connector pin-⑱ (terminated in 75Ω)
Instrument	Oscilloscope
Specification	300 mV±30 mVp-p

Check method:

Note: SCART OUT should be set to “S-Video”.

- 1) Insert the PAL reference disc and play back the 100% color bars.
- 2) Confirm that the burst signal level is 300 mV±30 mVp-p.

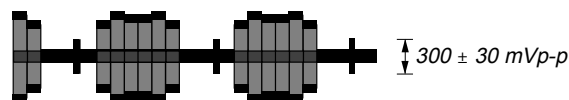

Fig. 7-9

10. Scart Video RGB Output R Check

<Purpose>

This check confirms that the RGB R signal output has the rated amplitude. If this signal level is not correct, brightness of the video signal will not be too dark or too thin when the Scart connector output signal is connected to a projector having Scart input.

Mode	PLAY
Signal	100% Color bars
Test point	Scart Video output R connector pin-⑲ (terminated in 75Ω)
Instrument	Oscilloscope
Specification	700 mV±50 mVp-p

Check method:

Note 1: RGB OUT should be set to ON.

Note 2: Do not connect the HDMI OUT.

- 1) Insert the PAL reference disc and play back the 100% color bars.
- 2) Confirm that the R signal level is 700 mV±50 mVp-p.

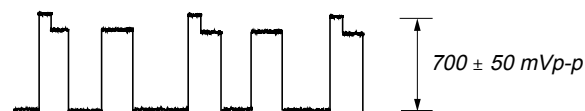

Fig. 7-10

11. Scart Video RGB Output G Check

<Purpose>

This check confirms that G signal of the RGB video conforms to the PAL standard. If this signal level is not correct, color of the video signal will have different color when the Scart connector output signal is connected to a projector having Scart input.

Mode	PLAY
Signal	100% Color bars
Test point	Scart Video output G connector pin-⑩ (terminated in 75Ω)
Instrument	Oscilloscope
Specification	700 mV±50 mVp-p

Check method:

Note 1: RGB OUT should be set to ON.

Note 2: Do not connect the HDMI OUT.

- 1) Insert the PAL reference disc and play back the 100% color bars.
- 2) Confirm that the G signal level is 700 mV±50 mVp-p.

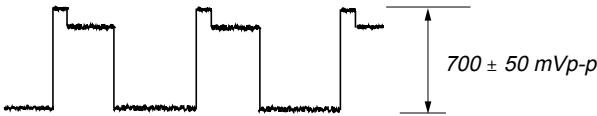

Fig. 7-11

12. Scart Video RGB Output B Check

<Purpose>

This check confirms that the B signal of the RGB video conforms to the PAL standard. If this signal level is not correct, color of the video signal will have different color when the Scart connector output signal is connected to a projector having Scart input.

Mode	PLAY
Signal	100% Color bars
Test point	Scart Video output B connector pin-⑦ (terminated in 75Ω)
Instrument	Oscilloscope
Specification	700 mV±50 mVp-p

Check method:

Note 1: RGB OUT should be set to ON.

Note 2: Do not connect the HDMI OUT.

- 1) Insert the PAL reference disc and play back the 100% color bars.
- 2) Confirm that the B signal level is 700 mV±50 mVp-p.

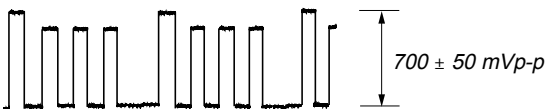

Fig. 7-12

**SECTION 8
REPAIR PARTS LIST**

8-1. EXPLODED VIEWS

NOTE:

- -XX, -X mean standardized parts, so they may have some differences from the original one.
- Items marked “*” are not stocked since they are seldom required for routine service. Some delay should be anticipated when ordering these items.
- The mechanical parts with no reference number in the exploded views are not supplied.

- Color Indication of Appearance Parts
Example:
KNOB, BALANCE (WHITE) . . . (RED)
Parts Color Cabinet's Color
- Abbreviation
AUS : Australian model

The components identified by mark Δ or dotted line with mark Δ are critical for safety. Replace only with part number specified.

The components identified by mark \square contain confidential information. Strictly follow the instructions whenever the components are repaired and/or replaced.

8-1-1. OVERALL SECTION

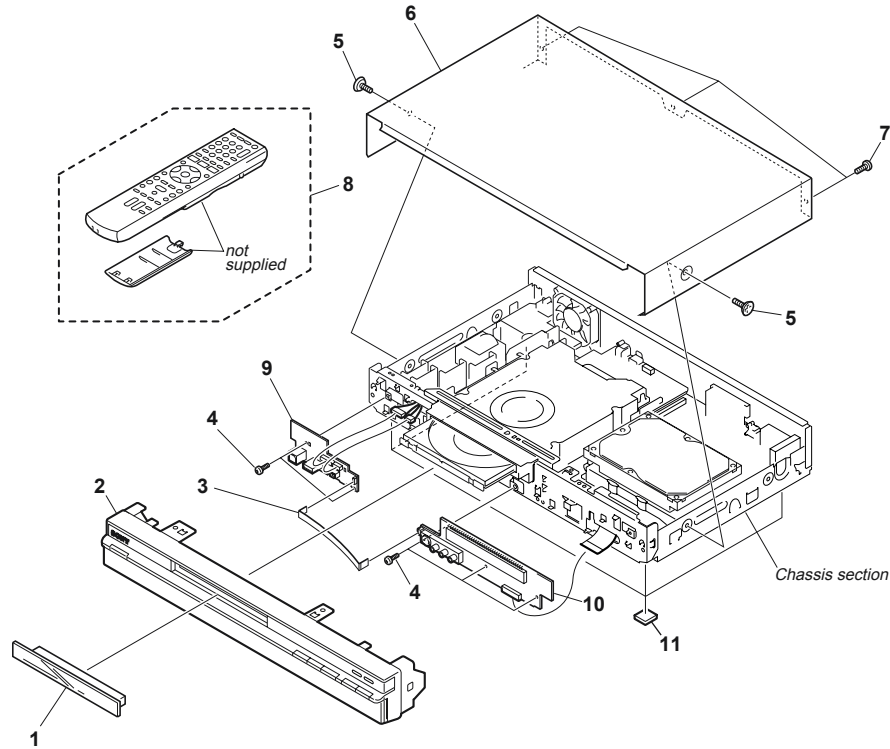

Ref. No.	Part No.	Description	Remarks	Ref. No.	Part No.	Description	Remarks
1	X-2187-503-1	COVER ASSY (DT), TRAY		2	A-1528-355-A	PANEL BLOCK ASSY, FRONT (BLACK)	
2	A-1526-898-A	PANEL BLOCK ASSY, FRONT (BLACK)	(HXD895)	3	1-834-076-21	CABLE, FLEXIBLE FLAT (FLR-010)	(HXD990: AUS)
2	A-1526-918-A	PANEL BLOCK ASSY, FRONT (SILVER)	(HXD895)	3	1-834-077-21	CABLE, FLEXIBLE FLAT (FLR-012)	(HXD790/HXD890/HXD990/HXD1090)
2	A-1526-934-A	PANEL BLOCK ASSY, FRONT (BLACK)	(HXD890: AEP, UK)	4	3-077-331-01	+BV3 (3-CR)	(HXD795/HXD895/HXD995/HXD1095)
2	A-1526-959-A	PANEL BLOCK ASSY, FRONT (SILVER)	(HXD890: AEP, UK)	5	3-070-883-41	SCREW, TAPPING (SILVER)	
2	A-1527-003-A	PANEL BLOCK ASSY, FRONT (BLACK)	(HXD790)	5	3-070-883-71	SCREW, TAPPING (BLACK)	
2	A-1527-007-A	PANEL BLOCK ASSY, FRONT (SILVER)	(HXD790)	6	2-899-646-01	CASE, UPPER (BLACK) (AEP, UK)	
2	A-1527-023-A	PANEL BLOCK ASSY, FRONT (BLACK)	(HXD795)	6	2-899-646-21	CASE, UPPER (SILVER) (AEP, UK)	
2	A-1527-031-A	PANEL BLOCK ASSY, FRONT (SILVER)	(HXD795)	6	A-1550-899-A	CASE BLOCK ASSY(SERVICE USE) (SILVER)	(AUS)
2	A-1527-063-A	PANEL BLOCK ASSY, FRONT (BLACK)	(HXD995)	6	A-1554-331-A	CASE BLCOK ASSY(SERVICE USE) (BLACK)	(AUS)
2	A-1527-086-A	PANEL BLOCK ASSY ,FRONT (BLACK)	(HXD990: AEP, UK)	7	3-076-563-11	SCREW, SPECIAL FRONT POINT	
2	A-1527-109-A	PANEL BLOCK ASSY, FRONT (BLACK)	(HXD1095)	8	1-480-698-11	REMOTE COMMANDER (RMT-D251P)	(AEP, UK)
2	A-1527-121-A	PANEL BLOCK ASSY, FRONT (BLACK)	(HXD1090)	8	1-480-700-11	REMOTE COMMANDER (RMT-D2510)(AUS)	
2	A-1528-248-A	PANEL BLOCK ASSY, FRONT (BLACK)	(HXD890: AUS)	9	A-1520-886-A	FL-184 (AG) COMPL (AEP, UK)	
2	A-1528-249-A	PANEL BLOCK ASSY, FRONT (SILVER)	(HXD890: AUS)	9	A-1543-613-A	FL-184 (AS) COMPL (AUS)	
				10	A-1520-888-A	FR-291 (AG) COMPL (AEP, UK)	
				10	A-1543-615-A	FR-291 (AS) COMPL (AUS)	
				* 11	3-087-319-01	CUSHION, FOOT	

8-1-2. CHASSIS SECTION

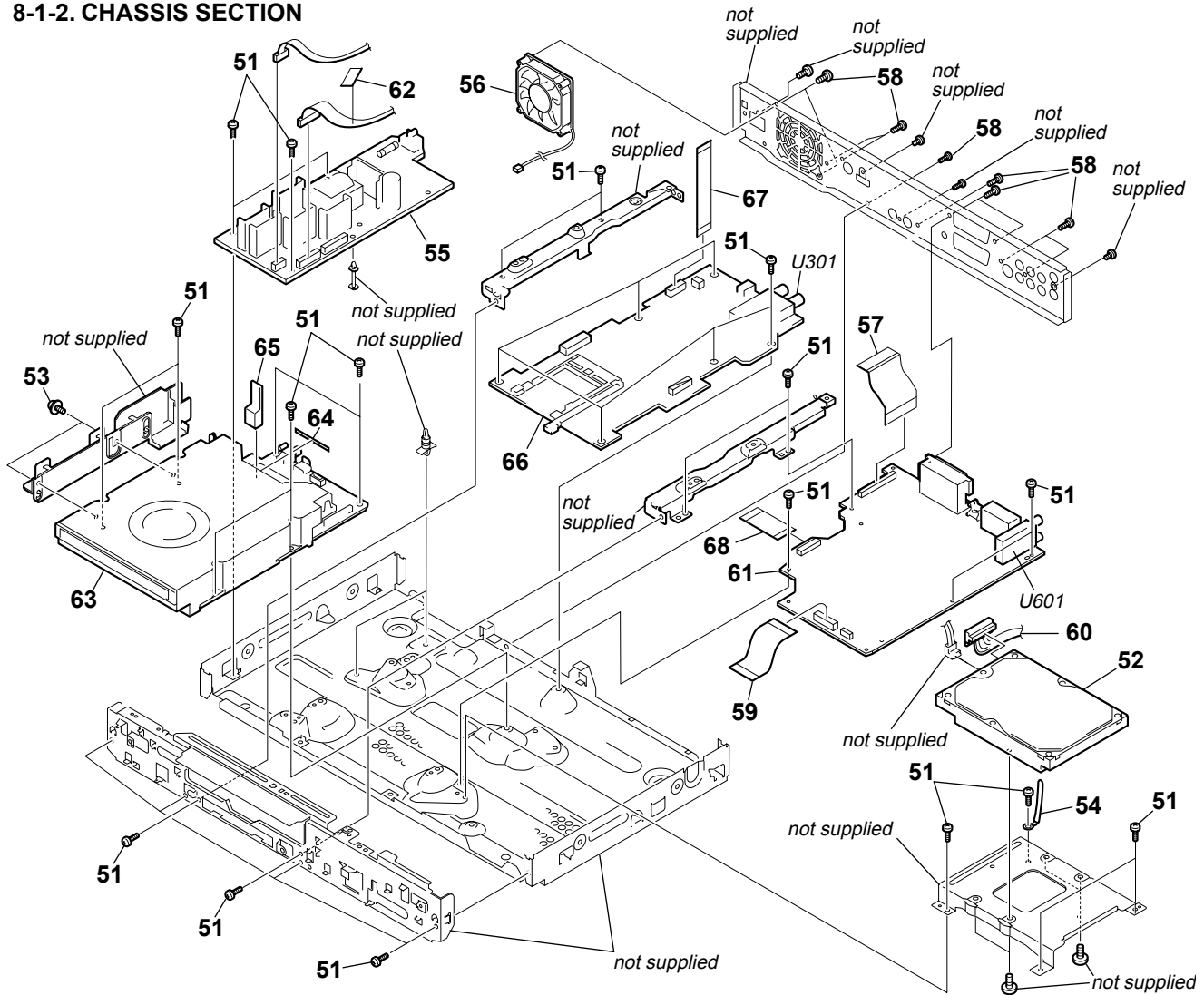

Ref. No.	Part No.	Description	Remarks	Ref. No.	Part No.	Description	Remarks
51	3-077-331-01	+BV3 (3-CR)		61	A-1520-892-A	AV-133 (CG) COMPL (AEP, UK)	
52	A-1544-210-A	HDD (SG-SUPERHAWK-S (250GB)-GA)		61	A-1550-351-A	AV-133 (AS) COMPL (AUS)	
		(HXD990: AUS)		62	3-087-220-01	TAPE, NON-HALOGENE	
52	A-1556-069-A	HDD (SG-NIGHTHAWK-S (160GB)-E) A		63	A-1543-920-A	DVR-U13HDD ASSY S COMPL (Note)	
		(HXD790/HXD795/HXD890: AEP, UK/HXD895)		64	2-684-970-01	SHIELD TAPE 1 (A)	
52	A-1556-070-A	HDD (SG-SUPERHAWK-S (250GB)-E)		65	3-268-333-02	SHIELD, GASKET	
		(HXD990: AEP, UK/HXD995)		66	A-1520-890-A	DT-124 (AG) COMPL	
52	A-1556-071-A	HDD (HG-GEMINI-S (500GB)-E) A				(HXD790/HXD890: AEP, UK/HXD990: AEP, UK/HXD1090)	
		(HXD1090/HXD1095)		66	A-1520-894-A	DT-124 (BG) COMPL	
52	A-1556-072-A	HDD (SG-NIGHTHAWK-S (160GB)-GA)				(HXD795/HXD895/HXD995/HXD1095)	
		(HXD890: AUS)		66	A-1550-357-A	DT-124 (AS) COMPL (AUS)	
53	7-682-947-01	SCREW +PSW 3X6		* 67	1-834-168-21	CABLE, FLEXIBLE FLAT (FVR-001)	
54	4-237-065-01	CLAMP (L35)		* 68	1-835-082-11	CABLE, FLEXIBLE FLAT (FAD-010)	
△ 55	1-474-047-11	REGULATOR, SWITCHING (SRV2057EK) (AUS)		△ U301	1-693-772-11	TUNER (TDQD5) (AEP, UK)	
△ 55	1-474-047-42	REGULATOR, SWITCHING (SRV2100EK)	(AEP, UK)	△ U301	1-693-772-21	TUNER (TDQD5) (AUS)	
56	1-787-624-11	FAN, DC		△ U601	1-693-741-11	TUNER (TMFE2-407A) (AUS)	
57	1-834-075-21	CABLE, FLEXIBLE FLAT (FRA-006)		△ U601	1-693-753-21	TUNER (TMFE2-408B) (AEP, UK)	
58	3-077-331-31	+BV3 (3-CR)					
* 59	1-835-081-11	CABLE, FLEXIBLE FLAT (FAR-008)					
60	1-965-191-21	HARNESS (RH-059)					

Note: When exchanging Traverse Mechanism in Ref No.63, please refer to the SERVICE MANUAL of "RW6G/7G TRAVERSE MECHANISM REPAIR MANUAL"

The components identified by mark △ or dotted line with mark △ are critical for safety. Replace only with part number specified.

The components identified by mark △ contain confidential information. Strictly follow the instructions whenever the components are repaired and/or replaced.

8-2. ELECTRICAL PARTS LIST

NOTE:

- Due to standardization, replacements in the parts list may be different from the parts specified in the diagrams or the components used on the set.
- -XX, -X mean standardized parts, so they may have some difference from the original one.
- Items marked "*" are not stocked since they are seldom required for routine service. Some delay should be anticipated when ordering these items.
- CAPACITORS:
uF: μ F
- COILS
uH: μ H

- RESISTORS
All resistors are in ohms.
METAL: metal-film resistor
METAL OXIDE: Metal Oxide-film resistor
F: nonflammable
- SEMICONDUCTORS
In each case, u: μ , for example:
uA...: μ A..., uPA..., μ PA...,
uPB..., μ PB..., uPC..., μ PC...,
uPD..., μ PD...
- Abbreviation
AUS : Australian model

When indicating parts by reference number, please include the board name.

The components identified by mark Δ or dotted line with mark Δ are critical for safety. Replace only with part number specified.

Ref. No.	Part No.	Description	Remarks	Ref. No.	Part No.	Description	Remarks
	A-1520-892-A	AV-133 (CG) BOARD, COMPLETE (AEP, UK)		C302	1-164-156-11	CERAMIC CHIP	0.1uF 25V
	A-1550-351-A	AV-133 (AS) BOARD, COMPLETE (AUS)		C303	1-126-933-11	ELECT	100uF 20% 16V
		(REF. NO.; 10,000 SERIES)		C305	1-164-156-11	CERAMIC CHIP	0.1uF 25V
		*****		C306	1-164-156-11	CERAMIC CHIP	0.1uF 25V
		< CAPACITOR >		C307	1-126-933-11	ELECT	100uF 20% 16V
C104	1-104-662-91	ELECT	22uF 20% 25V	C308	1-126-933-11	ELECT	100uF 20% 16V
C105	1-164-156-11	CERAMIC CHIP	0.1uF 25V	C309	1-164-156-11	CERAMIC CHIP	0.1uF 25V
C106	1-164-156-11	CERAMIC CHIP	0.1uF 25V	C310	1-164-156-11	CERAMIC CHIP	0.1uF 25V
C107	1-162-959-11	CERAMIC CHIP	330PF 5% 50V	C311	1-126-934-11	ELECT	220uF 20% 16V
C109	1-164-156-11	CERAMIC CHIP	0.1uF 25V	C312	1-126-933-11	ELECT	100uF 20% 16V
C110	1-165-908-11	CERAMIC CHIP	1uF 10% 10V	C314	1-164-156-11	CERAMIC CHIP	0.1uF 25V
C111	1-162-913-11	CERAMIC CHIP	8PF 0.5PF 50V	C315	1-126-933-11	ELECT	100uF 20% 16V
C112	1-162-914-11	CERAMIC CHIP	9PF 0.5PF 50V	C316	1-126-933-11	ELECT	100uF 20% 16V
C113	1-115-156-11	CERAMIC CHIP	1uF 10V	C318	1-164-156-11	CERAMIC CHIP	0.1uF 25V
C114	1-162-915-11	CERAMIC CHIP	10PF 0.5PF 50V	C319	1-126-933-11	ELECT	100uF 20% 16V
C115	1-162-915-11	CERAMIC CHIP	10PF 0.5PF 50V	C320	1-126-933-11	ELECT	100uF 20% 16V
C118	1-115-456-21	DOUBLE LAYER	0.22F 5.5V	C322	1-162-927-11	CERAMIC CHIP	100PF 5% 50V
C120	1-164-156-11	CERAMIC CHIP	0.1uF 25V	C323	1-100-162-91	CERAMIC CHIP	1uF 50V
C121	1-115-156-11	CERAMIC CHIP	1uF 10V	C324	1-164-156-11	CERAMIC CHIP	0.1uF 25V
C122	1-115-156-11	CERAMIC CHIP	1uF 10V	C326	1-126-964-11	ELECT	10uF 20% 50V
C124	1-164-156-11	CERAMIC CHIP	0.1uF 25V	C328	1-165-621-91	CERAMIC CHIP	0.1uF 50V
C125	1-164-156-11	CERAMIC CHIP	0.1uF 25V	C329	1-164-156-11	CERAMIC CHIP	0.1uF 25V
C126	1-164-156-11	CERAMIC CHIP	0.1uF 25V	C401	1-115-156-11	CERAMIC CHIP	1uF 10V
C127	1-126-933-11	ELECT	100uF 20% 16V	C402	1-162-927-11	CERAMIC CHIP	100PF 5% 50V
C131	1-164-156-11	CERAMIC CHIP	0.1uF 25V	C403	1-162-927-11	CERAMIC CHIP	100PF 5% 50V
C132	1-164-156-11	CERAMIC CHIP	0.1uF 25V	C404	1-115-156-11	CERAMIC CHIP	1uF 10V
C133	1-164-156-11	CERAMIC CHIP	0.1uF 25V	C406	1-107-826-11	CERAMIC CHIP	0.1uF 10% 16V
C134	1-164-156-11	CERAMIC CHIP	0.1uF 25V	C407	1-165-908-11	CERAMIC CHIP	1uF 10% 10V
C135	1-164-156-11	CERAMIC CHIP	0.1uF 25V	C408	1-165-908-11	CERAMIC CHIP	1uF 10% 10V
C138	1-126-961-11	ELECT	2.2uF 20% 50V	C409	1-165-908-11	CERAMIC CHIP	1uF 10% 10V
C139	1-164-156-11	CERAMIC CHIP	0.1uF 25V	C410	1-165-908-11	CERAMIC CHIP	1uF 10% 10V
C140	1-164-156-11	CERAMIC CHIP	0.1uF 25V	C411	1-165-908-11	CERAMIC CHIP	1uF 10% 10V
C141	1-115-156-11	CERAMIC CHIP	1uF 10V	C412	1-165-908-11	CERAMIC CHIP	1uF 10% 10V
C142	1-100-831-91	CERAMIC CHIP	0.001uF 2% 50V	C413	1-107-826-11	CERAMIC CHIP	0.1uF 10% 16V
C149	1-162-915-11	CERAMIC CHIP	10PF 0.5PF 50V	C414	1-164-156-11	CERAMIC CHIP	0.1uF 25V
C150	1-115-156-11	CERAMIC CHIP	1uF 10V	C415	1-164-156-11	CERAMIC CHIP	0.1uF 25V
C152	1-115-156-11	CERAMIC CHIP	1uF 10V	C418	1-115-156-11	CERAMIC CHIP	1uF 10V
C156	1-164-156-11	CERAMIC CHIP	0.1uF 25V	C419	1-165-908-11	CERAMIC CHIP	1uF 10% 10V
C157	1-107-826-11	CERAMIC CHIP	0.1uF 10% 16V	C420	1-165-908-11	CERAMIC CHIP	1uF 10% 10V
C202	1-164-156-11	CERAMIC CHIP	0.1uF 25V	C421	1-165-908-11	CERAMIC CHIP	1uF 10% 10V
C204	1-126-933-11	ELECT	100uF 20% 16V	C422	1-165-908-11	CERAMIC CHIP	1uF 10% 10V
C205	1-104-662-91	ELECT	22uF 20% 25V	C423	1-165-908-11	CERAMIC CHIP	1uF 10% 10V
C206	1-164-315-11	CERAMIC CHIP	470PF 5% 50V	C424	1-165-908-11	CERAMIC CHIP	1uF 10% 10V
C208	1-107-826-11	CERAMIC CHIP	0.1uF 10% 16V	C428	1-107-826-11	CERAMIC CHIP	0.1uF 10% 16V
C301	1-164-156-11	CERAMIC CHIP	0.1uF 25V	C429	1-165-908-11	CERAMIC CHIP	1uF 10% 10V

AV-133

Ref. No.	Part No.	Description	Remarks	Ref. No.	Part No.	Description	Remarks
C430	1-107-826-11	CERAMIC CHIP	0.1uF 10% 16V	C518	1-100-831-91	CERAMIC CHIP	0.001uF 2% 50V
C431	1-107-826-11	CERAMIC CHIP	0.1uF 10% 16V	C519	1-164-315-11	CERAMIC CHIP	470PF 5% 50V
C432	1-165-908-11	CERAMIC CHIP	1uF 10% 10V	C520	1-100-831-91	CERAMIC CHIP	0.001uF 2% 50V
C434	1-107-826-11	CERAMIC CHIP	0.1uF 10% 16V	C528	1-104-655-91	ELECT	470uF 20% 6.3V
C435	1-165-908-11	CERAMIC CHIP	1uF 10% 10V	C529	1-104-655-91	ELECT	470uF 20% 6.3V
C436	1-165-908-11	CERAMIC CHIP	1uF 10% 10V	C530	1-104-655-91	ELECT	470uF 20% 6.3V
C437	1-165-908-11	CERAMIC CHIP	1uF 10% 10V	C531	1-104-655-91	ELECT	470uF 20% 6.3V
C438	1-115-156-11	CERAMIC CHIP	1uF 10V	C532	1-104-655-91	ELECT	470uF 20% 6.3V
C439	1-107-826-11	CERAMIC CHIP	0.1uF 10% 16V	C541	1-126-963-11	ELECT	4.7uF 20% 50V
C440	1-107-826-11	CERAMIC CHIP	0.1uF 10% 16V	C542	1-126-963-11	ELECT	4.7uF 20% 50V
C441	1-115-156-11	CERAMIC CHIP	1uF 10V	C543	1-126-963-11	ELECT	4.7uF 20% 50V
C442	1-164-156-11	CERAMIC CHIP	0.1uF 25V	C544	1-126-963-11	ELECT	4.7uF 20% 50V
C443	1-165-908-11	CERAMIC CHIP	1uF 10% 10V	C545	1-126-933-11	ELECT	100uF 20% 16V
C444	1-165-908-11	CERAMIC CHIP	1uF 10% 10V	C547	1-104-662-91	ELECT	22uF 20% 25V
C445	1-165-908-11	CERAMIC CHIP	1uF 10% 10V	C550	1-104-662-91	ELECT	22uF 20% 25V
C446	1-165-908-11	CERAMIC CHIP	1uF 10% 10V	C551	1-104-662-91	ELECT	22uF 20% 25V
C447	1-107-726-91	CERAMIC CHIP	0.01uF 10% 16V	C552	1-162-927-11	CERAMIC CHIP	100PF 5% 50V
C450	1-107-713-11	ELECT	4.7uF 20% 50V	C602	1-162-966-11	CERAMIC CHIP	0.0022uF 10% 50V
C451	1-107-713-11	ELECT	4.7uF 20% 50V	C603	1-162-966-11	CERAMIC CHIP	0.0022uF 10% 50V
C452	1-104-658-91	ELECT	100uF 20% 10V	C604	1-162-927-11	CERAMIC CHIP	100PF 5% 50V
C453	1-104-658-91	ELECT	100uF 20% 10V	C605	1-162-915-11	CERAMIC CHIP	10PF 0.5PF 50V
C454	1-104-658-91	ELECT	100uF 20% 10V	C606	1-162-915-11	CERAMIC CHIP	10PF 0.5PF 50V
C455	1-126-963-11	ELECT	4.7uF 20% 50V	C608	1-125-891-11	CERAMIC CHIP	0.47uF 10% 10V
C456	1-126-960-11	ELECT	1uF 20% 50V	C609	1-104-658-91	ELECT	100uF 20% 10V
C457	1-126-964-11	ELECT	10uF 20% 50V	C611	1-126-947-11	ELECT	47uF 20% 35V
C458	1-104-658-91	ELECT	100uF 20% 10V	C613	1-164-156-11	CERAMIC CHIP	0.1uF 25V
C463	1-164-156-11	CERAMIC CHIP	0.1uF 25V	C614	1-164-156-11	CERAMIC CHIP	0.1uF 25V
C464	1-164-156-11	CERAMIC CHIP	0.1uF 25V	C615	1-162-927-11	CERAMIC CHIP	100PF 5% 50V
C468	1-164-156-11	CERAMIC CHIP	0.1uF 25V	C616	1-107-726-91	CERAMIC CHIP	0.01uF 10% 16V
C469	1-164-156-11	CERAMIC CHIP	0.1uF 25V	C617	1-164-156-11	CERAMIC CHIP	0.1uF 25V
C471	1-126-964-11	ELECT	10uF 20% 50V	C618	1-164-156-11	CERAMIC CHIP	0.1uF 25V
C472	1-126-964-11	ELECT	10uF 20% 50V	C619	1-164-156-11	CERAMIC CHIP	0.1uF 25V
C473	1-126-933-11	ELECT	100uF 20% 16V	C620	1-115-156-11	CERAMIC CHIP	1uF 10V
C474	1-126-964-11	ELECT	10uF 20% 50V	C621	1-162-924-11	CERAMIC CHIP	56PF 5% 50V
C475	1-126-964-11	ELECT	10uF 20% 50V	C622	1-162-924-11	CERAMIC CHIP	56PF 5% 50V
C476	1-107-726-91	CERAMIC CHIP	0.01uF 10% 16V	C623	1-162-908-11	CERAMIC CHIP	3PF 0.25PF 50V
C481	1-164-156-11	CERAMIC CHIP	0.1uF 25V	C624	1-162-908-11	CERAMIC CHIP	3PF 0.25PF 50V
C482	1-164-315-11	CERAMIC CHIP	470PF 5% 50V	C625	1-115-156-11	CERAMIC CHIP	1uF 10V
C484	1-164-315-11	CERAMIC CHIP	470PF 5% 50V	C626	1-164-156-11	CERAMIC CHIP	0.1uF 25V
C486	1-104-655-91	ELECT	470uF 20% 6.3V	C627	1-164-156-11	CERAMIC CHIP	0.1uF 25V
C487	1-104-655-91	ELECT	470uF 20% 6.3V	C628	1-107-726-91	CERAMIC CHIP	0.01uF 10% 16V
C488	1-104-655-91	ELECT	470uF 20% 6.3V	C629	1-164-173-11	CERAMIC CHIP	0.0039uF 10% 50V
C489	1-104-655-91	ELECT	470uF 20% 6.3V	C630	1-164-739-11	CERAMIC CHIP	560PF 5% 50V
C490	1-104-655-91	ELECT	470uF 20% 6.3V	C631	1-107-726-91	CERAMIC CHIP	0.01uF 10% 16V
C491	1-126-947-11	ELECT	47uF 20% 35V	C632	1-164-173-11	CERAMIC CHIP	0.0039uF 10% 50V
C492	1-126-923-91	ELECT	220uF 20% 10V	C633	1-164-739-11	CERAMIC CHIP	560PF 5% 50V
C493	1-126-947-11	ELECT	47uF 20% 35V	C635	1-162-919-11	CERAMIC CHIP	22PF 5% 50V
C496	1-164-156-11	CERAMIC CHIP	0.1uF 25V	C636	1-162-919-11	CERAMIC CHIP	22PF 5% 50V
C497	1-164-156-11	CERAMIC CHIP	0.1uF 25V	C638	1-126-964-11	ELECT	10uF 20% 50V
C498	1-164-156-11	CERAMIC CHIP	0.1uF 25V	C639	1-126-962-11	ELECT	3.3uF 20% 50V
C503	1-162-927-11	CERAMIC CHIP	100PF 5% 50V	C640	1-104-658-91	ELECT	100uF 20% 10V
C505	1-100-831-91	CERAMIC CHIP	0.001uF 2% 50V	C641	1-126-964-11	ELECT	10uF 20% 50V
C506	1-164-315-11	CERAMIC CHIP	470PF 5% 50V	C642	1-104-658-91	ELECT	100uF 20% 10V
C507	1-100-831-91	CERAMIC CHIP	0.001uF 2% 50V	C643	1-104-658-91	ELECT	100uF 20% 10V
C508	1-164-315-11	CERAMIC CHIP	470PF 5% 50V	C751	1-164-156-11	CERAMIC CHIP	0.1uF 25V (AEP, UK)
C510	1-164-156-11	CERAMIC CHIP	0.1uF 25V	C752	1-162-927-11	CERAMIC CHIP	100PF 5% 50V (AEP, UK)
C511	1-164-230-11	CERAMIC CHIP	220PF 5% 50V	C753	1-162-927-11	CERAMIC CHIP	100PF 5% 50V (AEP, UK)
C515	1-164-156-11	CERAMIC CHIP	0.1uF 25V	C754	1-162-927-11	CERAMIC CHIP	100PF 5% 50V (AEP, UK)
C516	1-164-315-11	CERAMIC CHIP	470PF 5% 50V				
C517	1-164-230-11	CERAMIC CHIP	220PF 5% 50V				

Ref. No.	Part No.	Description	Remarks	Ref. No.	Part No.	Description	Remarks
		< DIODE >				< IC >	
D101	8-719-081-97	DIODE MMDL914T1		IC101	6-712-674-01	IC LC87F06J2A-F59P6-E	
D102	8-719-081-97	DIODE MMDL914T1		* IC102	6-711-071-01	IC BD4846G-TR	
D103	8-719-081-97	DIODE MMDL914T1		* IC103	6-711-072-01	IC BU4220G-TR	
D104	8-719-053-18	DIODE 1SR154-400TE-25		* IC104	6-711-188-01	IC TC7MB3257FK (EL)	
D106	8-719-081-97	DIODE MMDL914T1		* IC401	6-711-073-01	IC HA118326APFR-E	
				IC402	8-759-909-71	IC BA4558F	
D108	8-719-941-09	DIODE DAP202U		IC406	8-759-082-60	IC TC7S66FU	
D201	8-719-081-97	DIODE MMDL914T1		IC601	6-702-714-01	IC MSP3417G-QG-B8V3	
D301	8-719-083-83	DIODE UDZSNPTE-1715B				< JACK >	
D302	6-500-028-01	DIODE MM3Z9V1ST1		JA401	1-794-198-11	CONNECTOR, S TERMINAL (LINE2 OUT)	
D303	8-719-081-97	DIODE MMDL914T1		JA751	1-764-188-31	JACK (SMALL TYPE) (DIA. 3.5) (G-LINK) (AEP, UK)	
D304	8-719-081-97	DIODE MMDL914T1				< TERMINAL >	
D409	8-719-081-42	DIODE UMZ6.8N-T106		KN101	1-537-771-21	TERMINAL BOARD, GROUND	
D410	8-719-081-42	DIODE UMZ6.8N-T106		KN102	1-537-771-21	TERMINAL BOARD, GROUND	
D413	8-719-081-42	DIODE UMZ6.8N-T106				< COIL >	
D414	8-719-081-42	DIODE UMZ6.8N-T106		L102	1-410-517-11	INDUCTOR 47uH	
D415	8-719-081-42	DIODE UMZ6.8N-T106		L201	1-412-549-31	INDUCTOR 1mH	
D416	8-719-081-42	DIODE UMZ6.8N-T106		L303	1-500-245-11	INDUCTOR, FERRITE BEAD	
D418	8-719-081-97	DIODE MMDL914T1		L304	1-408-621-31	INDUCTOR 330uH	
D419	8-719-081-97	DIODE MMDL914T1		L305	1-500-245-11	INDUCTOR, FERRITE BEAD	
D420	8-719-941-09	DIODE DAP202U		L501	1-414-594-11	INDUCTOR, FERRITE BEAD	
D421	6-501-486-01	DIODE NNCD3.9F-T1B		L502	1-414-594-11	INDUCTOR, FERRITE BEAD	
D422	6-501-486-01	DIODE NNCD3.9F-T1B		L601	1-500-245-11	INDUCTOR, FERRITE BEAD	
D501	8-719-976-99	DIODE DTZ5.1B		L602	1-500-245-11	INDUCTOR, FERRITE BEAD	
D502	8-719-976-99	DIODE DTZ5.1B		L604	1-414-760-21	INDUCTOR, FERRITE BEAD	
D503	6-501-486-01	DIODE NNCD3.9F-T1B		L605	1-414-760-21	INDUCTOR, FERRITE BEAD	
D504	8-719-081-42	DIODE UMZ6.8N-T106		L606	1-500-245-11	INDUCTOR, FERRITE BEAD	
D505	8-719-081-42	DIODE UMZ6.8N-T106		L607	1-412-963-11	INDUCTOR 100uH	
D506	8-719-081-42	DIODE UMZ6.8N-T106		L608	1-500-245-11	INDUCTOR, FERRITE BEAD	
D507	8-719-081-42	DIODE UMZ6.8N-T106		L609	1-412-951-11	INDUCTOR 10uH	
D508	6-501-486-01	DIODE NNCD3.9F-T1B		L751	1-414-760-21	INDUCTOR, FERRITE BEAD (AEP, UK)	
D509	8-719-081-42	DIODE UMZ6.8N-T106		L801	1-414-228-11	INDUCTOR, FERRITE BEAD	
D510	6-501-486-01	DIODE NNCD3.9F-T1B		L802	1-414-228-11	INDUCTOR, FERRITE BEAD	
D511	8-719-081-42	DIODE UMZ6.8N-T106		L803	1-216-864-11	SHORT CHIP 0	
D512	6-501-486-01	DIODE NNCD3.9F-T1B		L851	1-414-228-11	INDUCTOR, FERRITE BEAD	
D513	8-719-081-42	DIODE UMZ6.8N-T106		L852	1-414-228-11	INDUCTOR, FERRITE BEAD	
D514	8-719-081-42	DIODE UMZ6.8N-T106		L853	1-414-228-11	INDUCTOR, FERRITE BEAD	
D515	8-719-081-42	DIODE UMZ6.8N-T106		L854	1-414-228-11	INDUCTOR, FERRITE BEAD	
D516	8-719-081-42	DIODE UMZ6.8N-T106		L855	1-500-283-11	INDUCTOR, FERRITE BEAD	
D517	8-719-081-42	DIODE UMZ6.8N-T106		L856	1-414-228-11	INDUCTOR, FERRITE BEAD	
D518	8-719-081-42	DIODE UMZ6.8N-T106		L857	1-414-228-11	INDUCTOR, FERRITE BEAD	
D519	8-719-081-42	DIODE UMZ6.8N-T106		L858	1-414-228-11	INDUCTOR, FERRITE BEAD	
D520	8-719-081-42	DIODE UMZ6.8N-T106		L859	1-414-228-11	INDUCTOR, FERRITE BEAD	
D521	8-719-081-42	DIODE UMZ6.8N-T106		L860	1-500-283-11	INDUCTOR, FERRITE BEAD	
D522	8-719-081-42	DIODE UMZ6.8N-T106		L861	1-469-876-11	INDUCTOR, FERRITE BEAD	
D523	6-500-319-01	DIODE BAV99WT1		L862	1-469-796-21	FERRITE, CHIP	
D524	6-500-319-01	DIODE BAV99WT1				< TRANSISTOR >	
D526	8-719-081-97	DIODE MMDL914T1		Q101	8-729-029-06	TRANSISTOR DTC124EUA-T106	
D527	8-719-081-97	DIODE MMDL914T1		Q102	8-729-620-13	TRANSISTOR 2SC4154TP-1EF	
D528	8-719-081-97	DIODE MMDL914T1		Q103	6-550-375-01	TRANSISTOR UMD2N-TR	
D529	8-719-083-63	DIODE UDZSNPTE-1713B		Q104	6-550-375-01	TRANSISTOR UMD2N-TR	
D530	8-719-083-63	DIODE UDZSNPTE-1713B		Q105	8-729-023-22	TRANSISTOR 2SD2114K	
D531	8-719-081-42	DIODE UMZ6.8N-T106					
D801	8-719-081-42	DIODE UMZ6.8N-T106					
		< FUSE >					
△ IC150	1-576-796-11	FUSE 0.5A 32V					
△ IC317	1-576-796-11	FUSE 0.5A 32V					

Note : The components identified by mark △ or dotted line with mark △ are critical for safety. Replace only with part number specified.

AV-133

Ref. No.	Part No.	Description	Remarks	Ref. No.	Part No.	Description	Remarks
Q108	8-729-029-06	TRANSISTOR	DTC124EUA-T106	R112	1-216-833-11	METAL CHIP	10K 5% 1/10W
Q110	8-729-028-86	TRANSISTOR	DTA143EUA-T106 (AEP, UK)	R113	1-216-864-11	SHORT CHIP	0
Q111	8-729-620-13	TRANSISTOR	2SC4154TP-1EF	R116	1-216-864-11	SHORT CHIP	0
Q112	8-729-620-13	TRANSISTOR	2SC4154TP-1EF	R117	1-216-857-11	METAL CHIP	1M 5% 1/10W
Q201	8-729-023-22	TRANSISTOR	2SD2114K	R118	1-216-864-11	SHORT CHIP	0
Q301	6-550-375-01	TRANSISTOR	UMD2N-TR	R123	1-216-815-11	METAL CHIP	330 5% 1/10W
Q302	8-729-620-13	TRANSISTOR	2SC4154TP-1EF	R124	1-216-815-11	METAL CHIP	330 5% 1/10W
Q303	6-550-375-01	TRANSISTOR	UMD2N-TR	R125	1-216-809-11	METAL CHIP	100 5% 1/10W
Q304	8-729-044-09	TRANSISTOR	2SD2153T100V	R126	1-216-809-11	METAL CHIP	100 5% 1/10W
Q305	6-550-375-01	TRANSISTOR	UMD2N-TR	R127	1-216-833-11	METAL CHIP	10K 5% 1/10W
Q306	8-729-901-91	TRANSISTOR	2SC2411K-T-146-CQ	R129	1-216-815-11	METAL CHIP	330 5% 1/10W
Q307	6-550-375-01	TRANSISTOR	UMD2N-TR	R130	1-216-864-11	SHORT CHIP	0
Q308	8-729-901-91	TRANSISTOR	2SC2411K-T-146-CQ	R131	1-216-829-11	METAL CHIP	4.7K 5% 1/10W
* Q309	6-551-719-01	TRANSISTOR	2SC5876T106QR	R132	1-216-867-11	METAL CHIP	6.8K 0.5% 1/10W
Q310	8-729-620-13	TRANSISTOR	2SC4154TP-1EF	R133	1-216-845-11	METAL CHIP	100K 5% 1/10W
Q311	8-729-427-70	TRANSISTOR	XP4401	R134	1-216-821-11	METAL CHIP	1K 5% 1/10W
Q401	8-729-029-06	TRANSISTOR	DTC124EUA-T106	R135	1-216-845-11	METAL CHIP	100K 5% 1/10W
Q402	8-729-023-22	TRANSISTOR	2SD2114K	R137	1-216-809-11	METAL CHIP	100 5% 1/10W
Q403	6-551-699-01	TRANSISTOR	ISA1602AM1TP-1EF	R138	1-216-817-11	METAL CHIP	470 5% 1/10W
Q404	6-550-375-01	TRANSISTOR	UMD2N-TR	R139	1-218-867-11	METAL CHIP	6.8K 0.5% 1/10W
Q406	8-729-023-22	TRANSISTOR	2SD2114K	R140	1-216-864-11	SHORT CHIP	0
Q407	8-729-023-22	TRANSISTOR	2SD2114K	R141	1-218-867-11	METAL CHIP	6.8K 0.5% 1/10W
Q408	8-729-620-13	TRANSISTOR	2SC4154TP-1EF	R142	1-216-864-11	SHORT CHIP	0
Q410	8-729-620-13	TRANSISTOR	2SC4154TP-1EF	R143	1-216-809-11	METAL CHIP	100 5% 1/10W
Q411	6-550-375-01	TRANSISTOR	UMD2N-TR	R144	1-216-864-11	SHORT CHIP	0
Q413	8-729-029-06	TRANSISTOR	DTC124EUA-T106	R145	1-216-833-11	METAL CHIP	10K 5% 1/10W
Q501	6-551-718-01	TRANSISTOR	UMH1NTN	R146	1-216-809-11	METAL CHIP	100 5% 1/10W
Q502	6-551-699-01	TRANSISTOR	ISA1602AM1TP-1EF	R147	1-216-821-11	METAL CHIP	1K 5% 1/10W
Q503	8-729-620-13	TRANSISTOR	2SC4154TP-1EF	R148	1-216-809-11	METAL CHIP	100 5% 1/10W
Q504	8-729-620-13	TRANSISTOR	2SC4154TP-1EF	R149	1-216-864-11	SHORT CHIP	0
Q505	8-729-620-13	TRANSISTOR	2SC4154TP-1EF	R150	1-216-864-11	SHORT CHIP	0
Q506	8-729-013-26	TRANSISTOR	HN1C03FU-TE85R	R151	1-216-864-11	SHORT CHIP	0
Q507	8-729-013-26	TRANSISTOR	HN1C03FU-TE85R	R152	1-216-864-11	SHORT CHIP	0
Q508	8-729-028-83	TRANSISTOR	DTA124EUA-T106	R153	1-216-809-11	METAL CHIP	100 5% 1/10W
Q509	8-729-620-13	TRANSISTOR	2SC4154TP-1EF	R154	1-216-809-11	METAL CHIP	100 5% 1/10W
Q510	8-729-620-13	TRANSISTOR	2SC4154TP-1EF	R155	1-216-809-11	METAL CHIP	100 5% 1/10W
Q511	6-551-699-01	TRANSISTOR	ISA1602AM1TP-1EF	R156	1-216-809-11	METAL CHIP	100 5% 1/10W
Q601	6-551-699-01	TRANSISTOR	ISA1602AM1TP-1EF	R157	1-216-845-11	METAL CHIP	100K 5% 1/10W
Q602	6-551-699-01	TRANSISTOR	ISA1602AM1TP-1EF	R158	1-216-845-11	METAL CHIP	100K 5% 1/10W
Q604	6-551-699-01	TRANSISTOR	ISA1602AM1TP-1EF	R159	1-216-864-11	SHORT CHIP	0
Q605	6-551-699-01	TRANSISTOR	ISA1602AM1TP-1EF	R160	1-216-809-11	METAL CHIP	100 5% 1/10W
Q606	8-729-620-13	TRANSISTOR	2SC4154TP-1EF	R161	1-216-864-11	SHORT CHIP	0
Q751	6-551-699-01	TRANSISTOR	ISA1602AM1TP-1EF (AEP, UK)	R165	1-216-864-11	SHORT CHIP	0
Q752	8-729-620-13	TRANSISTOR	2SC4154TP-1EF (AEP, UK)	R167	1-216-809-11	METAL CHIP	100 5% 1/10W
Q801	8-729-620-13	TRANSISTOR	2SC4154TP-1EF	R168	1-216-812-11	METAL CHIP	180 5% 1/10W
< RESISTOR >				R169	1-216-833-11	METAL CHIP	10K 5% 1/10W
R101	1-216-809-11	METAL CHIP	100 5% 1/10W	R171	1-216-809-11	METAL CHIP	100 5% 1/10W
R102	1-216-809-11	METAL CHIP	100 5% 1/10W	R172	1-216-809-11	METAL CHIP	100 5% 1/10W
R103	1-216-809-11	METAL CHIP	100 5% 1/10W	R173	1-216-845-11	METAL CHIP	100K 5% 1/10W
R104	1-216-841-11	METAL CHIP	47K 5% 1/10W	R174	1-216-845-11	METAL CHIP	100K 5% 1/10W
R105	1-216-809-11	METAL CHIP	100 5% 1/10W	R175	1-216-815-11	METAL CHIP	330 5% 1/10W
R106	1-216-864-11	SHORT CHIP	0	R176	1-216-821-11	METAL CHIP	1K 5% 1/10W
R107	1-216-833-11	METAL CHIP	10K 5% 1/10W	R177	1-216-809-11	METAL CHIP	100 5% 1/10W
R109	1-216-815-11	METAL CHIP	330 5% 1/10W	R178	1-216-809-11	METAL CHIP	100 5% 1/10W
R110	1-216-809-11	METAL CHIP	100 5% 1/10W	R179	1-216-809-11	METAL CHIP	100 5% 1/10W
R111	1-216-809-11	METAL CHIP	100 5% 1/10W	R180	1-216-809-11	METAL CHIP	100 5% 1/10W
				R181	1-216-809-11	METAL CHIP	100 5% 1/10W
				R182	1-216-809-11	METAL CHIP	100 5% 1/10W
				R188	1-216-815-11	METAL CHIP	330 5% 1/10W
				R189	1-216-817-11	METAL CHIP	470 5% 1/10W

Ref. No.	Part No.	Description	Quantity	Percentage	Remarks	Ref. No.	Part No.	Description	Quantity	Percentage	Remarks
R193	1-216-845-11	METAL CHIP	100K	5%	1/10W	R431	1-216-857-11	METAL CHIP	1M	5%	1/10W
R194	1-216-845-11	METAL CHIP	100K	5%	1/10W	R432	1-216-857-11	METAL CHIP	1M	5%	1/10W
R195	1-216-845-11	METAL CHIP	100K	5%	1/10W	R433	1-216-857-11	METAL CHIP	1M	5%	1/10W
R197	1-216-864-11	SHORT CHIP	0			R435	1-216-857-11	METAL CHIP	1M	5%	1/10W
R199	1-216-809-11	METAL CHIP	100	5%	1/10W	R436	1-216-809-11	METAL CHIP	100	5%	1/10W
R200	1-216-815-11	METAL CHIP	330	5%	1/10W	R437	1-216-809-11	METAL CHIP	100	5%	1/10W
R201	1-216-864-11	SHORT CHIP	0 (AEP, UK)			R439	1-216-860-11	METAL CHIP	1.8M	5%	1/10W
R202	1-216-864-11	SHORT CHIP	0			R444	1-208-755-11	METAL CHIP	75	0.5%	1/10W
R203	1-216-864-11	SHORT CHIP	0			R445	1-208-755-11	METAL CHIP	75	0.5%	1/10W
R204	1-216-809-11	METAL CHIP	100	5%	1/10W	R447	1-208-755-11	METAL CHIP	75	0.5%	1/10W
R205	1-216-809-11	METAL CHIP	100	5%	1/10W	R453	1-218-869-11	METAL CHIP	8.2K	0.5%	1/10W
R207	1-216-817-11	METAL CHIP	470	5%	1/10W	R454	1-218-871-11	METAL CHIP	10K	0.5%	1/10W
R208	1-216-864-11	SHORT CHIP	0 (AEP, UK)			R455	1-216-805-11	METAL CHIP	47	5%	1/10W
R209	1-216-827-11	METAL CHIP	3.3K	5%	1/10W	R458	1-216-817-11	METAL CHIP	470	5%	1/10W
R210	1-218-845-11	METAL CHIP	820	0.5%	1/10W	R460	1-216-864-11	SHORT CHIP	0		
R214	1-216-827-11	METAL CHIP	3.3K	5%	1/10W	R461	1-216-819-11	METAL CHIP	680	5%	1/10W
R215	1-216-819-11	METAL CHIP	680	5%	1/10W	R462	1-218-871-11	METAL CHIP	10K	0.5%	1/10W
R216	1-218-844-11	METAL CHIP	750	0.5%	1/10W	R463	1-218-869-11	METAL CHIP	8.2K	0.5%	1/10W
R217	1-216-821-11	METAL CHIP	1K	5%	1/10W	R465	1-216-817-11	METAL CHIP	470	5%	1/10W
R219	1-216-827-11	METAL CHIP	3.3K	5%	1/10W	R468	1-208-754-11	METAL CHIP	68	0.5%	1/10W
R220	1-216-825-11	METAL CHIP	2.2K	5%	1/10W	R469	1-216-306-11	RES-CHIP	3.9	5%	1/10W
R221	1-216-809-11	METAL CHIP	100	5%	1/10W	R470	1-208-755-11	METAL CHIP	75	0.5%	1/10W
R222	1-216-864-11	SHORT CHIP	0			R471	1-216-295-91	SHORT CHIP	0		
R223	1-216-864-11	SHORT CHIP	0			R472	1-208-754-11	METAL CHIP	68	0.5%	1/10W
R224	1-216-864-11	SHORT CHIP	0			R473	1-216-306-11	RES-CHIP	3.9	5%	1/10W
R225	1-216-835-11	METAL CHIP	15K	5%	1/10W	R474	1-208-754-11	METAL CHIP	68	0.5%	1/10W
R228	1-216-864-11	SHORT CHIP	0			R475	1-216-306-11	RES-CHIP	3.9	5%	1/10W
R233	1-216-845-11	METAL CHIP	100K	5%	1/10W	R476	1-208-754-11	METAL CHIP	68	0.5%	1/10W
R240	1-216-864-11	SHORT CHIP	0			R477	1-216-306-11	RES-CHIP	3.9	5%	1/10W
R241	1-216-864-11	SHORT CHIP	0			R478	1-208-754-11	METAL CHIP	68	0.5%	1/10W
R242	1-216-864-11	SHORT CHIP	0			R479	1-216-817-11	METAL CHIP	470	5%	1/10W
R255	1-216-809-11	METAL CHIP	100	5%	1/10W	R480	1-216-306-11	RES-CHIP	3.9	5%	1/10W
R256	1-216-809-11	METAL CHIP	100	5%	1/10W	R482	1-216-809-11	METAL CHIP	100	5%	1/10W
R304	1-216-809-11	METAL CHIP	100	5%	1/10W	R484	1-216-821-11	METAL CHIP	1K	5%	1/10W
R305	1-216-803-11	METAL CHIP	33	5%	1/10W	R485	1-216-837-11	METAL CHIP	22K	5%	1/10W
R306	1-216-803-11	METAL CHIP	33	5%	1/10W	R486	1-216-821-11	METAL CHIP	1K	5%	1/10W
R309	1-216-823-11	METAL CHIP	1.5K	5%	1/10W	R487	1-216-837-11	METAL CHIP	22K	5%	1/10W
R310	1-216-829-11	METAL CHIP	4.7K	5%	1/10W	R488	1-216-817-11	METAL CHIP	470	5%	1/10W
R311	1-216-820-11	METAL CHIP	820	5%	1/10W	R490	1-216-809-11	METAL CHIP	100	5%	1/10W
R312	1-216-833-11	METAL CHIP	10K	5%	1/10W	R501	1-208-755-11	METAL CHIP	75	0.5%	1/10W
R313	1-216-848-11	METAL CHIP	180K	5%	1/10W	R502	1-208-755-11	METAL CHIP	75	0.5%	1/10W
R314	1-216-837-11	METAL CHIP	22K	5%	1/10W	R503	1-208-755-11	METAL CHIP	75	0.5%	1/10W
R315	1-218-895-11	METAL CHIP	100K	0.5%	1/10W	R504	1-208-754-11	METAL CHIP	68	0.5%	1/10W
R316	1-218-879-11	METAL CHIP	22K	0.5%	1/10W	R504	1-216-295-91	SHORT CHIP	0 (AUS)		
R402	1-216-818-11	METAL CHIP	560	5%	1/10W	R505	1-208-755-11	METAL CHIP	75	0.5%	1/10W (AUS)
R403	1-216-818-11	METAL CHIP	560	5%	1/10W						
R408	1-216-817-11	METAL CHIP	470	5%	1/10W						
R413	1-216-817-11	METAL CHIP	470	5%	1/10W	R505	1-216-306-11	RES-CHIP	3.9	5%	1/10W (AEP, UK)
R414	1-216-817-11	METAL CHIP	470	5%	1/10W						
R415	1-216-817-11	METAL CHIP	470	5%	1/10W						
R416	1-216-817-11	METAL CHIP	470	5%	1/10W	R506	1-216-864-11	SHORT CHIP	0		
R417	1-216-817-11	METAL CHIP	470	5%	1/10W	R507	1-216-829-11	METAL CHIP	4.7K	5%	1/10W
R418	1-216-817-11	METAL CHIP	470	5%	1/10W	R508	1-216-841-11	METAL CHIP	47K	5%	1/10W
R419	1-216-817-11	METAL CHIP	470	5%	1/10W	R509	1-216-838-11	METAL CHIP	27K	5%	1/10W
R420	1-216-860-11	METAL CHIP	1.8M	5%	1/10W						
R421	1-216-860-11	METAL CHIP	1.8M	5%	1/10W	R510	1-216-861-11	METAL CHIP	2.2M	5%	1/10W
R422	1-216-833-11	METAL CHIP	10K	5%	1/10W	R511	1-216-849-11	METAL CHIP	220K	5%	1/10W
R425	1-216-845-11	METAL CHIP	100K	5%	1/10W	R512	1-216-845-11	METAL CHIP	100K	5%	1/10W
R428	1-216-864-11	SHORT CHIP	0			R513	1-216-845-11	METAL CHIP	100K	5%	1/10W
R430	1-216-857-11	METAL CHIP	1M	5%	1/10W	R514	1-208-755-11	METAL CHIP	75	0.5%	1/10W

AV-133

Ref. No.	Part No.	Description	Remarks	Ref. No.	Part No.	Description	Remarks
R515	1-216-043-91	RES-CHIP	560 5%	1/10W	R602	1-216-821-11	METAL CHIP 1K 5% 1/10W
R516	1-216-822-11	METAL CHIP	1.2K 5%	1/10W	R603	1-216-864-11	SHORT CHIP 0
R517	1-216-823-11	METAL CHIP	1.5K 5%	1/10W	R605	1-216-833-11	METAL CHIP 10K 5% 1/10W
R518	1-216-797-11	METAL CHIP	10 5%	1/10W	R606	1-216-833-11	METAL CHIP 10K 5% 1/10W
R519	1-216-842-11	METAL CHIP	56K 5%	1/10W	R607	1-216-821-11	METAL CHIP 1K 5% 1/10W
R520	1-216-813-11	METAL CHIP	220 5%	1/10W	R609	1-216-864-11	SHORT CHIP 0
R521	1-208-754-11	METAL CHIP	68 0.5%	1/10W	R616	1-216-864-11	SHORT CHIP 0
R522	1-216-306-11	RES-CHIP	3.9 5%	1/10W	R619	1-216-833-11	METAL CHIP 10K 5% 1/10W
R523	1-208-754-11	METAL CHIP	68 0.5%	1/10W	R620	1-216-864-11	SHORT CHIP 0
R524	1-216-306-11	RES-CHIP	3.9 5%	1/10W	R621	1-216-809-11	METAL CHIP 100 5% 1/10W
R525	1-208-754-11	METAL CHIP	68 0.5%	1/10W	R622	1-216-809-11	METAL CHIP 100 5% 1/10W
R526	1-216-306-11	RES-CHIP	3.9 5%	1/10W	R623	1-216-821-11	METAL CHIP 1K 5% 1/10W
R527	1-216-295-91	SHORT CHIP	0		R624	1-216-827-11	METAL CHIP 3.3K 5% 1/10W
R528	1-208-755-11	METAL CHIP	75 0.5%	1/10W	R625	1-216-827-11	METAL CHIP 3.3K 5% 1/10W
R529	1-216-845-11	METAL CHIP	100K 5%	1/10W	R626	1-216-821-11	METAL CHIP 1K 5% 1/10W
R530	1-208-755-11	METAL CHIP	75 0.5%	1/10W	R627	1-216-827-11	METAL CHIP 3.3K 5% 1/10W
R531	1-216-295-91	SHORT CHIP	0		R628	1-216-827-11	METAL CHIP 3.3K 5% 1/10W
R532	1-208-755-11	METAL CHIP	75 0.5%	1/10W	R630	1-216-815-11	METAL CHIP 330 5% 1/10W
R534	1-216-828-11	METAL CHIP	3.9K 5%	1/10W	R631	1-216-829-11	METAL CHIP 4.7K 5% 1/10W
R535	1-216-828-11	METAL CHIP	3.9K 5%	1/10W	R632	1-216-801-11	METAL CHIP 22 5% 1/10W
R536	1-216-817-11	METAL CHIP	470 5%	1/10W	R633	1-216-809-11	METAL CHIP 100 5% 1/10W
R537	1-216-809-11	METAL CHIP	100 5%	1/10W	R634	1-216-825-11	METAL CHIP 2.2K 5% 1/10W
R538	1-216-817-11	METAL CHIP	470 5%	1/10W	R635	1-400-330-21	INDUCTOR, FERRITE BEAD (1608)
R539	1-216-809-11	METAL CHIP	100 5%	1/10W	R636	1-400-330-21	INDUCTOR, FERRITE BEAD (1608)
R540	1-216-845-11	METAL CHIP	100K 5%	1/10W	R637	1-400-330-21	INDUCTOR, FERRITE BEAD (1608)
R541	1-216-845-11	METAL CHIP	100K 5%	1/10W	R638	1-216-809-11	METAL CHIP 100 5% 1/10W
R542	1-216-809-11	METAL CHIP	100 5%	1/10W	R701	1-216-849-11	METAL CHIP 220K 5% 1/10W
R543	1-216-809-11	METAL CHIP	100 5%	1/10W	R751	1-216-821-11	METAL CHIP 1K 5% 1/10W
R544	1-216-809-11	METAL CHIP	100 5%	1/10W			(AEP, UK)
R545	1-216-809-11	METAL CHIP	100 5%	1/10W	R752	1-216-829-11	METAL CHIP 4.7K 5% 1/10W
R546	1-216-845-11	METAL CHIP	100K 5%	1/10W			(AEP, UK)
R547	1-216-845-11	METAL CHIP	100K 5%	1/10W	R753	1-216-829-11	METAL CHIP 4.7K 5% 1/10W
R548	1-216-845-11	METAL CHIP	100K 5%	1/10W			(AEP, UK)
R549	1-216-845-11	METAL CHIP	100K 5%	1/10W	R754	1-216-811-11	METAL CHIP 150 5% 1/10W
R550	1-216-817-11	METAL CHIP	470 5%	1/10W			(AEP, UK)
R551	1-216-809-11	METAL CHIP	100 5%	1/10W	R755	1-216-829-11	METAL CHIP 4.7K 5% 1/10W
R552	1-216-817-11	METAL CHIP	470 5%	1/10W			(AEP, UK)
R553	1-216-809-11	METAL CHIP	100 5%	1/10W	R756	1-216-821-11	METAL CHIP 1K 5% 1/10W
R554	1-216-845-11	METAL CHIP	100K 5%	1/10W			(AEP, UK)
R555	1-216-845-11	METAL CHIP	100K 5%	1/10W	R802	1-216-857-11	METAL CHIP 1M 5% 1/10W
R556	1-216-828-11	METAL CHIP	3.9K 5%	1/10W	R810	1-216-805-11	METAL CHIP 47 5% 1/10W
R557	1-216-828-11	METAL CHIP	3.9K 5%	1/10W	R811	1-216-817-11	METAL CHIP 470 5% 1/10W
R558	1-216-833-11	METAL CHIP	10K 5%	1/10W			< TUNER >
R559	1-216-864-11	SHORT CHIP	0		△ U601	1-693-741-11	TUNER (TMFE2-407A) (AUS)
R560	1-216-835-11	METAL CHIP	15K 5%	1/10W	△ U601	1-693-753-21	TUNER (TMFE2-408B) (AEP, UK)
R561	1-216-819-11	METAL CHIP	680 5%	1/10W			< VIBRATOR >
R562	1-216-833-11	METAL CHIP	10K 5%	1/10W			
R563	1-216-864-11	SHORT CHIP	0		* X101	1-813-965-31	VIBRATOR, CRYSTAL (15MHz)
R564	1-216-835-11	METAL CHIP	15K 5%	1/10W	X102	1-795-950-11	VIBRATOR, CRYSTAL (32.768kHz)
R565	1-216-819-11	METAL CHIP	680 5%	1/10W	* X601	1-813-713-21	VIBRATOR, CRYSTAL (18.432MHz)
R566	1-216-837-11	METAL CHIP	22K 5%	1/10W			*****
R568	1-216-834-11	METAL CHIP	12K 5%	1/10W			
R569	1-216-821-11	METAL CHIP	1K 5%	1/10W			
R571	1-208-755-11	METAL CHIP	75 0.5%	1/10W			
R573	1-500-283-11	INDUCTOR, FERRITE BEAD					

Note : The components identified by mark △ or dotted line with mark △ are critical for safety. Replace only with part number specified.

Ref. No.	Part No.	Description	Remarks	Ref. No.	Part No.	Description	Remarks
A-1520-890-A	DT-124 (AG) BOARD, COMPLETE (HXD790/HXD890: AEP, UK/HXD990: AEP, UK/HXD1090)			C194	1-115-156-11	CERAMIC CHIP 1uF	10V
A-1520-894-A	DT-124 (BG) BOARD, COMPLETE (HXD795/HXD895/HXD995/HXD1095)			C209	1-164-156-11	CERAMIC CHIP 0.1uF	25V
A-1550-357-A	DT-124 (AS) BOARD, COMPLETE (AUS) (REF. NO.: 40,000 SERIES) *****			C210	1-117-681-11	ELECT CHIP 100uF 20% (HXD795/HXD895/HXD995/HXD1095)	16V
7-621-255-55	SCREW +P 2X8 (HXD795/HXD895/HXD995/HXD1095)			C211	1-126-204-11	ELECT CHIP 47uF 20% (HXD795/HXD895/HXD995/HXD1095)	16V
	< CAPACITOR >			C212	1-114-130-11	CERAMIC CHIP 1uF 10% (HXD795/HXD895/HXD995/HXD1095)	6.3V
C101	1-115-156-11	CERAMIC CHIP 1uF	10V	C213	1-107-820-11	CERAMIC CHIP 0.1uF	16V
C102	1-164-156-11	CERAMIC CHIP 0.1uF	25V	C221	1-117-681-11	ELECT CHIP 100uF 20% (HXD795/HXD895/HXD995/HXD1095)	16V
C103	1-162-964-11	CERAMIC CHIP 0.001uF 10%	50V	C222	1-114-130-11	CERAMIC CHIP 1uF 10% (HXD795/HXD895/HXD995/HXD1095)	6.3V
C104	1-164-156-11	CERAMIC CHIP 0.1uF	25V	C301	1-165-908-11	CERAMIC CHIP 1uF 10%	10V
C105	1-162-964-11	CERAMIC CHIP 0.001uF 10%	50V	C302	1-117-681-11	ELECT CHIP 100uF 20%	16V
C106	1-164-156-11	CERAMIC CHIP 0.1uF	25V	C303	1-162-927-11	CERAMIC CHIP 100PF 5%	50V
C107	1-115-156-11	CERAMIC CHIP 1uF	10V	C304	1-165-908-11	CERAMIC CHIP 1uF 10%	10V
C108	1-164-156-11	CERAMIC CHIP 0.1uF	25V	C307	1-117-681-11	ELECT CHIP 100uF 20%	16V
C109	1-164-156-11	CERAMIC CHIP 0.1uF	25V	C309	1-165-908-11	CERAMIC CHIP 1uF 10%	10V
C110	1-164-156-11	CERAMIC CHIP 0.1uF	25V	C312	1-100-966-91	CERAMIC CHIP 10uF 20%	10V
C111	1-115-156-11	CERAMIC CHIP 1uF	10V	C313	1-127-760-11	CERAMIC CHIP 4.7uF 10%	6.3V
C112	1-164-156-11	CERAMIC CHIP 0.1uF	25V	C314	1-127-760-11	CERAMIC CHIP 4.7uF 10% (HXD795/HXD895/HXD995/HXD1095)	6.3V
C113	1-115-156-11	CERAMIC CHIP 1uF	10V	C315	1-127-760-11	CERAMIC CHIP 4.7uF 10%	6.3V
C114	1-164-156-11	CERAMIC CHIP 0.1uF	25V	C318	1-117-681-11	ELECT CHIP 100uF 20% (HXD795/HXD895/HXD995/HXD1095)	16V
C115	1-126-210-21	ELECT CHIP 220uF 20%	4V	C319	1-117-681-11	ELECT CHIP 100uF 20%	16V
C116	1-164-156-11	CERAMIC CHIP 0.1uF	25V	C320	1-127-760-11	CERAMIC CHIP 4.7uF 10%	6.3V
C117	1-115-156-11	CERAMIC CHIP 1uF	10V	C324	1-124-778-00	ELECT CHIP 22uF 20%	6.3V
C118	1-164-156-11	CERAMIC CHIP 0.1uF	25V	C329	1-117-681-11	ELECT CHIP 100uF 20% (HXD795/HXD895/HXD995/HXD1095)	16V
C119	1-115-156-11	CERAMIC CHIP 1uF	10V	C332	1-125-889-11	CERAMIC CHIP 2.2uF 10%	10V
C120	1-164-156-11	CERAMIC CHIP 0.1uF	25V	C334	1-127-760-11	CERAMIC CHIP 4.7uF 10% (HXD795/HXD895/HXD995/HXD1095)	6.3V
C121	1-115-156-11	CERAMIC CHIP 1uF	10V	C339	1-117-681-11	ELECT CHIP 100uF 20%	16V
C122	1-164-156-11	CERAMIC CHIP 0.1uF	25V	C340	1-165-908-11	CERAMIC CHIP 1uF 10%	10V
C124	1-164-156-11	CERAMIC CHIP 0.1uF	25V	C341	1-165-908-11	CERAMIC CHIP 1uF 10%	10V
C125	1-164-156-11	CERAMIC CHIP 0.1uF	25V	C342	1-126-204-11	ELECT CHIP 47uF 20%	16V
C126	1-115-156-11	CERAMIC CHIP 1uF	10V	C343	1-126-204-11	ELECT CHIP 47uF 20%	16V
C127	1-164-156-11	CERAMIC CHIP 0.1uF	25V	C353	1-124-779-00	ELECT CHIP 10uF 20%	16V
C128	1-164-156-11	CERAMIC CHIP 0.1uF	25V	C354	1-165-908-11	CERAMIC CHIP 1uF 10%	10V
C129	1-115-156-11	CERAMIC CHIP 1uF	10V	C356	1-162-919-11	CERAMIC CHIP 22PF 5%	50V
C130	1-164-156-11	CERAMIC CHIP 0.1uF	25V	C359	1-164-156-11	CERAMIC CHIP 0.1uF	25V
C131	1-164-156-11	CERAMIC CHIP 0.1uF	25V	C361	1-162-919-11	CERAMIC CHIP 22PF 5%	50V
C134	1-164-156-11	CERAMIC CHIP 0.1uF	25V	C364	1-164-156-11	CERAMIC CHIP 0.1uF	25V
C135	1-164-156-11	CERAMIC CHIP 0.1uF	25V	C367	1-126-197-11	ELECT CHIP 10uF 20%	50V
C136	1-115-156-11	CERAMIC CHIP 1uF	10V	C368	1-117-681-11	ELECT CHIP 100uF 20%	16V
C137	1-115-156-11	CERAMIC CHIP 1uF	10V	C370	1-162-927-11	CERAMIC CHIP 100PF 5%	50V
C138	1-164-156-11	CERAMIC CHIP 0.1uF	25V	C372	1-164-156-11	CERAMIC CHIP 0.1uF	25V
C140	1-164-156-11	CERAMIC CHIP 0.1uF	25V	C373	1-125-889-11	CERAMIC CHIP 2.2uF 10%	10V
C142	1-164-156-11	CERAMIC CHIP 0.1uF	25V	C380	1-164-156-11	CERAMIC CHIP 0.1uF	25V
C144	1-117-681-11	ELECT CHIP 100uF 20%	16V	C381	1-117-681-11	ELECT CHIP 100uF 20%	16V
C147	1-126-204-11	ELECT CHIP 47uF 20%	16V	C382	1-117-681-11	ELECT CHIP 100uF 20%	16V
C148	1-162-907-11	CERAMIC CHIP 2PF 0.25PF	50V	C383	1-164-156-11	CERAMIC CHIP 0.1uF	25V
C149	1-162-907-11	CERAMIC CHIP 2PF 0.25PF	50V	C385	1-126-204-11	ELECT CHIP 47uF 20%	16V
C155	1-164-156-11	CERAMIC CHIP 0.1uF	25V	C388	1-165-908-11	CERAMIC CHIP 1uF 10%	10V
C191	1-115-156-11	CERAMIC CHIP 1uF	10V	C391	1-162-970-11	CERAMIC CHIP 0.01uF 10%	25V
C192	1-164-156-11	CERAMIC CHIP 0.1uF	25V	C392	1-125-889-11	CERAMIC CHIP 2.2uF 10%	10V
C193	1-115-156-11	CERAMIC CHIP 1uF	10V	C393	1-125-889-11	CERAMIC CHIP 2.2uF 10%	10V

Ref. No.	Part No.	Description	Remarks	Ref. No.	Part No.	Description	Remarks
C395	1-126-204-11	ELECT CHIP	47uF 20% 16V	C3004	1-107-820-11	CERAMIC CHIP 0.1uF 16V (HXD795/HXD895/HXD995/HXD1095)	
C396	1-164-227-11	CERAMIC CHIP	0.022uF 10% 25V	C3005	1-107-820-11	CERAMIC CHIP 0.1uF 16V (HXD795/HXD895/HXD995/HXD1095)	
C397	1-162-915-11	CERAMIC CHIP	10PF 0.5PF 50V	C3006	1-114-130-11	CERAMIC CHIP 1uF 10% 6.3V (HXD795/HXD895/HXD995/HXD1095)	
C398	1-164-156-11	CERAMIC CHIP	0.1uF 25V	C3007	1-114-130-11	CERAMIC CHIP 1uF 10% 6.3V (HXD795/HXD895/HXD995/HXD1095)	
C399	1-164-156-11	CERAMIC CHIP	0.1uF 25V	C3008	1-107-820-11	CERAMIC CHIP 0.1uF 16V (HXD795/HXD895/HXD995/HXD1095)	
C400	1-164-227-11	CERAMIC CHIP	0.022uF 10% 25V	C3009	1-107-820-11	CERAMIC CHIP 0.1uF 16V (HXD795/HXD895/HXD995/HXD1095)	
C402	1-162-916-11	CERAMIC CHIP	12PF 5% 50V	C3010	1-107-820-11	CERAMIC CHIP 0.1uF 16V (HXD795/HXD895/HXD995/HXD1095)	
C404	1-125-889-11	CERAMIC CHIP	2.2uF 10% 10V	C3011	1-107-820-11	CERAMIC CHIP 0.1uF 16V (HXD795/HXD895/HXD995/HXD1095)	
C406	1-115-156-11	CERAMIC CHIP	1uF 10V	C3012	1-107-820-11	CERAMIC CHIP 0.1uF 16V (HXD795/HXD895/HXD995/HXD1095)	
C408	1-164-156-11	CERAMIC CHIP	0.1uF 25V	C3013	1-107-820-11	CERAMIC CHIP 0.1uF 16V (HXD795/HXD895/HXD995/HXD1095)	
C409	1-107-826-11	CERAMIC CHIP	0.1uF 10% 16V	C3016	1-114-130-11	CERAMIC CHIP 1uF 10% 6.3V (HXD795/HXD895/HXD995/HXD1095)	
C412	1-164-156-11	CERAMIC CHIP	0.1uF 25V	C3017	1-126-204-11	ELECT CHIP 47uF 20% 16V (HXD795/HXD895/HXD995/HXD1095)	
C413	1-107-826-11	CERAMIC CHIP	0.1uF 10% 16V	C3022	1-125-889-11	CERAMIC CHIP 2.2uF 10% 10V (HXD795/HXD895/HXD995/HXD1095)	
C415	1-164-156-11	CERAMIC CHIP	0.1uF 25V	C3023	1-107-820-11	CERAMIC CHIP 0.1uF 16V (HXD795/HXD895/HXD995/HXD1095)	
C416	1-164-156-11	CERAMIC CHIP	0.1uF 25V			< CONNECTOR >	
C417	1-115-156-11	CERAMIC CHIP	1uF 10V	CN103	1-779-287-11	FFC CONNECTOR (LIF (NON-ZIF)) 19P	
C418	1-115-156-11	CERAMIC CHIP	1uF 10V	* CN202	1-564-728-11	PIN, CONNECTOR (SMALL TYPE) 12P	
C421	1-115-156-11	CERAMIC CHIP	1uF 10V	CN203	1-564-704-41	PIN, CONNECTOR (SMALL TYPE) 2P	
C422	1-164-156-11	CERAMIC CHIP	0.1uF 25V			< DIODE >	
C423	1-164-156-11	CERAMIC CHIP	0.1uF 25V (HXD795/HXD895/HXD995/HXD1095)	* D302	6-501-864-01	DIODE SM15T6V8A	
C431	1-125-889-11	CERAMIC CHIP	2.2uF 10% 10V	D303	8-719-081-97	DIODE MMDL914T1	
C433	1-127-760-11	CERAMIC CHIP	4.7uF 10% 6.3V			< FUSE >	
C522	1-164-156-11	CERAMIC CHIP	0.1uF 25V	F101	1-543-949-22	BEAD, FERRITE (CHIP) (1608)	
C524	1-164-156-11	CERAMIC CHIP	0.1uF 25V	F102	1-543-949-22	BEAD, FERRITE (CHIP) (1608)	
C528	1-164-227-11	CERAMIC CHIP	0.022uF 10% 25V	F103	1-543-949-22	BEAD, FERRITE (CHIP) (1608)	
C590	1-162-915-11	CERAMIC CHIP	10PF 0.5PF 50V	F104	1-543-949-22	BEAD, FERRITE (CHIP) (1608)	
C591	1-162-915-11	CERAMIC CHIP	10PF 0.5PF 50V	F105	1-543-949-22	BEAD, FERRITE (CHIP) (1608)	
C592	1-162-915-11	CERAMIC CHIP	10PF 0.5PF 50V	F106	1-543-949-22	BEAD, FERRITE (CHIP) (1608)	
C593	1-164-156-11	CERAMIC CHIP	0.1uF 25V	F108	1-543-949-22	BEAD, FERRITE (CHIP) (1608)	
C594	1-164-156-11	CERAMIC CHIP	0.1uF 25V	F202	1-543-949-22	BEAD, FERRITE (CHIP) (1608)	
C595	1-126-210-21	ELECT CHIP	220uF 20% 4V	F300	1-543-949-22	BEAD, FERRITE (CHIP) (1608)	
C596	1-164-156-11	CERAMIC CHIP	0.1uF 25V	F301	1-543-949-22	BEAD, FERRITE (CHIP) (1608)	
C597	1-126-210-21	ELECT CHIP	220uF 20% 4V	F302	1-543-949-22	BEAD, FERRITE (CHIP) (1608)	
C598	1-164-156-11	CERAMIC CHIP	0.1uF 25V	F306	1-543-949-22	BEAD, FERRITE (CHIP) (1608)	
C599	1-117-681-11	ELECT CHIP	100uF 20% 16V	F309	1-543-949-22	BEAD, FERRITE (CHIP) (1608)	
C600	1-164-156-11	CERAMIC CHIP	0.1uF 25V	F310	1-543-949-22	BEAD, FERRITE (CHIP) (1608)	
C601	1-117-681-11	ELECT CHIP	100uF 20% 16V	F313	1-543-949-22	BEAD, FERRITE (CHIP) (1608)	
C602	1-127-760-11	CERAMIC CHIP	4.7uF 10% 6.3V	F314	1-543-949-22	BEAD, FERRITE (CHIP) (1608)	
C603	1-124-778-00	ELECT CHIP	22uF 20% 6.3V	F317	1-543-949-22	BEAD, FERRITE (CHIP) (1608)	
C614	1-164-156-11	CERAMIC CHIP	0.1uF 25V	F318	1-543-949-22	BEAD, FERRITE (CHIP) (1608)	
C615	1-164-156-11	CERAMIC CHIP	0.1uF 25V	F321	1-543-949-22	BEAD, FERRITE (CHIP) (1608)	
C616	1-125-889-11	CERAMIC CHIP	2.2uF 10% 10V	F397	1-543-949-22	BEAD, FERRITE (CHIP) (1608)	
C618	1-100-966-91	CERAMIC CHIP	10uF 20% 10V	F398	1-543-949-22	BEAD, FERRITE (CHIP) (1608)	
C620	1-100-966-91	CERAMIC CHIP	10uF 20% 10V				
C801	1-115-156-11	CERAMIC CHIP	1uF 10V				
C802	1-115-156-11	CERAMIC CHIP	1uF 10V				
C803	1-125-777-11	CERAMIC CHIP	0.1uF 10% 10V				
C804	1-126-205-11	ELECT CHIP	47uF 20% 6.3V				
C805	1-164-874-11	CERAMIC CHIP	100PF 5% 50V				
C806	1-164-874-11	CERAMIC CHIP	100PF 5% 50V				
C807	1-164-858-11	CERAMIC CHIP	22PF 5% 50V				
C808	1-164-858-11	CERAMIC CHIP	22PF 5% 50V				
C3001	1-107-820-11	CERAMIC CHIP	0.1uF 16V (HXD795/HXD895/HXD995/HXD1095)				
C3002	1-107-820-11	CERAMIC CHIP	0.1uF 16V (HXD795/HXD895/HXD995/HXD1095)				
C3003	1-107-820-11	CERAMIC CHIP	0.1uF 16V (HXD795/HXD895/HXD995/HXD1095)				

Ref. No.	Part No.	Description	Remarks	Ref. No.	Part No.	Description	Remarks
		< IC >				< RESISTOR >	
IC101	6-705-306-01	IC HYB25DC256160CE-6		R100	1-216-864-11	SHORT CHIP	0
* IC104	6-711-077-01	IC KA5SDKAS01TSN		R101	1-216-833-11	METAL CHIP	10K 5% 1/10W
IC106	6-711-206-01	IC uPD61111GM-200-UEV-A		R104	1-216-833-11	METAL CHIP	10K 5% 1/10W
IC207	6-712-693-01	IC AAT4610AIJS-1-T1 (HXD795/HXD895/HXD995/HXD1095)		R107	1-216-864-11	SHORT CHIP	0
* IC304	6-712-691-01	IC S-1132B50-U5T1G		R109	1-216-864-11	SHORT CHIP	0
IC306	6-711-050-01	IC S-1170B50UC-OUJTFG (HXD795/HXD895/HXD995/HXD1095)		R110	1-216-806-11	METAL CHIP	56 5% 1/10W
* IC307	6-711-027-01	IC MM1689FHBE		R111	1-216-806-11	METAL CHIP	56 5% 1/10W
* IC309	6-711-146-01	IC PFP2007		R114	1-216-803-11	METAL CHIP	33 5% 1/10W
* IC312	6-712-691-01	IC S-1132B50-U5T1G		R116	1-216-833-11	METAL CHIP	10K 5% 1/10W
* IC313	6-711-223-01	IC DRX3975D		R121	1-218-823-11	METAL CHIP	100 0.5% 1/10W
IC3001	6-707-850-01	IC TC74LCX245FT (EKJ) (HXD795/HXD895/HXD995/HXD1095)		R122	1-218-823-11	METAL CHIP	100 0.5% 1/10W
IC3002	6-707-853-01	IC TC74LCX541FT (EKJ) (HXD795/HXD895/HXD995/HXD1095)		R123	1-218-823-11	METAL CHIP	100 0.5% 1/10W
IC3003	6-707-853-01	IC TC74LCX541FT (EKJ) (HXD795/HXD895/HXD995/HXD1095)		R124	1-218-823-11	METAL CHIP	100 0.5% 1/10W
IC3004	6-707-853-01	IC TC74LCX541FT (EKJ) (HXD795/HXD895/HXD995/HXD1095)		R125	1-218-823-11	METAL CHIP	100 0.5% 1/10W
IC3005	6-707-853-01	IC TC74LCX541FT (EKJ) (HXD795/HXD895/HXD995/HXD1095)		R126	1-218-823-11	METAL CHIP	100 0.5% 1/10W
IC3006	8-759-475-49	IC TC74LCX257FT (EL) (HXD795/HXD895/HXD995/HXD1095)		R127	1-218-823-11	METAL CHIP	100 0.5% 1/10W
IC3007	8-759-475-49	IC TC74LCX257FT (EL) (HXD795/HXD895/HXD995/HXD1095)		R128	1-218-823-11	METAL CHIP	100 0.5% 1/10W
IC3008	8-759-475-49	IC TC74LCX257FT (EL) (HXD795/HXD895/HXD995/HXD1095)		R141	1-216-833-11	METAL CHIP	10K 5% 1/10W
IC3009	6-707-853-01	IC TC74LCX541FT (EKJ) (HXD795/HXD895/HXD995/HXD1095)		R145	1-216-833-11	METAL CHIP	10K 5% 1/10W
IC3010	6-707-853-01	IC TC74LCX541FT (EKJ) (HXD795/HXD895/HXD995/HXD1095)		R146	1-216-833-11	METAL CHIP	10K 5% 1/10W
IC3011	6-707-858-01	IC TC74VHC00FT (EKJ) (HXD795/HXD895/HXD995/HXD1095)		R148	1-216-833-11	METAL CHIP	10K 5% 1/10W
IC3015	6-707-851-01	IC TC74LCX32FT (EKJ) (HXD795/HXD895/HXD995/HXD1095)		R149	1-216-841-11	METAL CHIP	47K 5% 1/10W
		< COIL >		R151	1-216-841-11	METAL CHIP	47K 5% 1/10W
L314	1-469-110-21	FERRITE, EMI (SMD) (1608)		R153	1-216-841-11	METAL CHIP	47K 5% 1/10W
L315	1-400-703-21	(3216, EMI FERRITE (SMD))		R154	1-216-841-11	METAL CHIP	47K 5% 1/10W
L801	1-469-555-21	INDUCTOR 10uH		R155	1-216-841-11	METAL CHIP	47K 5% 1/10W
L3001	1-543-949-22	BEAD, FERRITE (CHIP) (1608) (HXD795/HXD895/HXD995/HXD1095)		R159	1-216-809-11	METAL CHIP	100 5% 1/10W
		< TRANSISTOR >		R160	1-216-809-11	METAL CHIP	100 5% 1/10W
Q202	8-729-028-86	TRANSISTOR DTA143EUA-T106 (HXD795/HXD895/HXD995/HXD1095)		R166	1-218-846-11	METAL CHIP	910 0.5% 1/10W
Q203	8-729-620-13	TRANSISTOR 2SC4154TP-1EF (HXD795/HXD895/HXD995/HXD1095)		R167	1-218-846-11	METAL CHIP	910 0.5% 1/10W
Q204	8-729-029-06	TRANSISTOR DTC124EUA-T106 (HXD795/HXD895/HXD995/HXD1095)		R168	1-218-831-11	METAL CHIP	220 0.5% 1/10W
Q205	8-729-427-72	TRANSISTOR XP4501 (HXD795/HXD895/HXD995/HXD1095)		R169	1-218-827-11	METAL CHIP	150 0.5% 1/10W
Q306	6-551-699-01	TRANSISTOR ISA1602AM1TP-1EF		R170	1-216-803-11	METAL CHIP	33 5% 1/10W
Q307	8-729-620-13	TRANSISTOR 2SC4154TP-1EF		R173	1-216-806-11	METAL CHIP	56 5% 1/10W
Q308	8-729-620-13	TRANSISTOR 2SC4154TP-1EF		R174	1-216-806-11	METAL CHIP	56 5% 1/10W
Q309	8-729-029-09	TRANSISTOR DTC143EUA-T106		R175	1-216-806-11	METAL CHIP	56 5% 1/10W
Q310	8-729-029-09	TRANSISTOR DTC143EUA-T106		R178	1-216-806-11	METAL CHIP	56 5% 1/10W
Q801	6-551-699-01	TRANSISTOR ISA1602AM1TP-1EF		R179	1-216-833-11	METAL CHIP	10K 5% 1/10W
Q802	6-551-699-01	TRANSISTOR ISA1602AM1TP-1EF		R180	1-216-806-11	METAL CHIP	56 5% 1/10W
Q803	8-729-620-13	TRANSISTOR 2SC4154TP-1EF		R182	1-216-864-11	SHORT CHIP	0
Q804	8-729-620-13	TRANSISTOR 2SC4154TP-1EF		R183	1-216-864-11	SHORT CHIP	0
				* R185	1-234-714-11	RES, NETWORK	56 (1005X4)
				* R186	1-234-714-11	RES, NETWORK	56 (1005X4)
				R187	1-234-791-21	RES, NETWORK	150X4 (2010) (AEP, UK)
				R187	1-200-051-21	RES, NETWORK	150 (1005X4) (AUS)
				R188	1-234-372-11	RES, NETWORK	100 (1005X4)
				R189	1-234-372-11	RES, NETWORK	100 (1005X4)
				R190	1-234-372-11	RES, NETWORK	100 (1005X4)
				R191	1-234-372-11	RES, NETWORK	100 (1005X4)
				R192	1-234-372-11	RES, NETWORK	100 (1005X4)
				* R193	1-234-714-11	RES, NETWORK	56 (1005X4)
				* R194	1-234-714-11	RES, NETWORK	56 (1005X4)
				R197	1-216-864-11	SHORT CHIP	0
				R198	1-216-833-11	METAL CHIP	10K 5% 1/10W
				R199	1-216-864-11	SHORT CHIP	0

DT-124

Ref. No.	Part No.	Description	Remarks	Ref. No.	Part No.	Description	Remarks
R231	1-216-820-11	METAL CHIP 820 5% 1/10W (HXD795/HXD895/HXD995/HXD1095)		R341	1-216-828-11	METAL CHIP 3.9K 5% 1/10W	
R239	1-234-791-21	RES, NETWORK 150X4 (2010) (AEP, UK)		R342	1-216-828-11	METAL CHIP 3.9K 5% 1/10W	
R239	1-200-051-21	RES, NETWORK 150 (1005X4) (AUS)		R343	1-216-864-11	SHORT CHIP 0	
R240	1-234-791-21	RES, NETWORK 150X4 (2010) (AEP, UK)		R345	1-216-864-11	SHORT CHIP 0	
R240	1-200-051-21	RES, NETWORK 150 (1005X4) (AUS)		R347	1-216-864-11	SHORT CHIP 0	
R241	1-234-791-21	RES, NETWORK 150X4 (2010) (AEP, UK)		R348	1-216-864-11	SHORT CHIP 0	
R241	1-200-051-21	RES, NETWORK 150 (1005X4) (AUS)		R349	1-216-864-11	SHORT CHIP 0	
R242	1-234-791-21	RES, NETWORK 150X4 (2010) (AEP, UK)		R350	1-216-864-11	SHORT CHIP 0	
R242	1-200-051-21	RES, NETWORK 150 (1005X4) (AUS)		R351	1-216-833-11	METAL CHIP 10K 5% 1/10W	
R243	1-234-791-21	RES, NETWORK 150X4 (2010) (AEP, UK)		R352	1-216-833-11	METAL CHIP 10K 5% 1/10W	
R243	1-200-051-21	RES, NETWORK 150 (1005X4) (AUS)		R353	1-216-837-11	METAL CHIP 22K 5% 1/10W	
R244	1-234-791-21	RES, NETWORK 150X4 (2010) (AEP, UK)		R357	1-216-864-11	SHORT CHIP 0	
R244	1-200-051-21	RES, NETWORK 150 (1005X4) (AUS)		R358	1-216-837-11	METAL CHIP 22K 5% 1/10W	
R245	1-234-791-21	RES, NETWORK 150X4 (2010) (AEP, UK)		R359	1-216-833-11	METAL CHIP 10K 5% 1/10W	
R245	1-200-051-21	RES, NETWORK 150 (1005X4) (AUS)		R363	1-216-833-11	METAL CHIP 10K 5% 1/10W	
R246	1-234-371-21	RES, NETWORK 47 (1005X4)		R532	1-216-864-11	SHORT CHIP 0	
R247	1-234-371-21	RES, NETWORK 47 (1005X4)		R534	1-216-864-11	SHORT CHIP 0	
R248	1-234-371-21	RES, NETWORK 47 (1005X4)		R535	1-216-837-11	METAL CHIP 22K 5% 1/10W	
R249	1-234-371-21	RES, NETWORK 47 (1005X4)		R538	1-216-837-11	METAL CHIP 22K 5% 1/10W	
R250	1-218-965-11	RES-CHIP 10K 5% 1/16W		R540	1-216-837-11	METAL CHIP 22K 5% 1/10W	
R251	1-218-965-11	RES-CHIP 10K 5% 1/16W		R542	1-216-837-11	METAL CHIP 22K 5% 1/10W	
R253	1-218-937-11	RES-CHIP 47 5% 1/16W		R544	1-216-837-11	METAL CHIP 22K 5% 1/10W	
R254	1-218-937-11	RES-CHIP 47 5% 1/16W (HXD795/HXD895/HXD995/HXD1095)		R546	1-216-837-11	METAL CHIP 22K 5% 1/10W	
R258	1-218-965-11	RES-CHIP 10K 5% 1/16W (HXD795/HXD895/HXD995/HXD1095)		R547	1-216-837-11	METAL CHIP 22K 5% 1/10W	
R259	1-218-965-11	RES-CHIP 10K 5% 1/16W (HXD795/HXD895/HXD995/HXD1095)		R550	1-216-837-11	METAL CHIP 22K 5% 1/10W	
R269	1-218-971-11	RES-CHIP 33K 5% 1/16W (HXD795/HXD895/HXD995/HXD1095)		R551	1-216-837-11	METAL CHIP 22K 5% 1/10W	
R270	1-218-973-11	RES-CHIP 47K 5% 1/16W (HXD795/HXD895/HXD995/HXD1095)		R554	1-216-837-11	METAL CHIP 22K 5% 1/10W	
R271	1-218-969-11	RES-CHIP 22K 5% 1/16W (HXD795/HXD895/HXD995/HXD1095)		R556	1-216-837-11	METAL CHIP 22K 5% 1/10W	
R272	1-218-965-11	RES-CHIP 10K 5% 1/16W (HXD795/HXD895/HXD995/HXD1095)		R558	1-216-837-11	METAL CHIP 22K 5% 1/10W	
R273	1-218-965-11	RES-CHIP 10K 5% 1/16W (HXD795/HXD895/HXD995/HXD1095)		R560	1-216-837-11	METAL CHIP 22K 5% 1/10W	
R275	1-218-965-11	RES-CHIP 10K 5% 1/16W (HXD795/HXD895/HXD995/HXD1095)		R561	1-216-837-11	METAL CHIP 22K 5% 1/10W	
R304	1-216-833-11	METAL CHIP 10K 5% 1/10W		R564	1-216-837-11	METAL CHIP 22K 5% 1/10W	
R306	1-216-864-11	SHORT CHIP 0		R566	1-216-837-11	METAL CHIP 22K 5% 1/10W	
R307	1-216-864-11	SHORT CHIP 0		R568	1-216-837-11	METAL CHIP 22K 5% 1/10W	
R309	1-216-825-11	METAL CHIP 2.2K 5% 1/10W		R569	1-216-809-11	METAL CHIP 100 5% 1/10W	
R310	1-216-825-11	METAL CHIP 2.2K 5% 1/10W		R570	1-216-809-11	METAL CHIP 100 5% 1/10W	
R311	1-216-819-11	METAL CHIP 680 5% 1/10W		R571	1-216-864-11	SHORT CHIP 0	
R312	1-216-809-11	METAL CHIP 100 5% 1/10W		R572	1-216-864-11	SHORT CHIP 0	
R313	1-216-829-11	METAL CHIP 4.7K 5% 1/10W		R575	1-216-833-11	METAL CHIP 10K 5% 1/10W	
R314	1-216-829-11	METAL CHIP 4.7K 5% 1/10W		R577	1-216-864-11	SHORT CHIP 0	
R315	1-216-833-11	METAL CHIP 10K 5% 1/10W		R580	1-216-833-11	METAL CHIP 10K 5% 1/10W	
R319	1-216-841-11	METAL CHIP 47K 5% 1/10W		R589	1-216-864-11	SHORT CHIP 0	
R321	1-216-829-11	METAL CHIP 4.7K 5% 1/10W		R594	1-216-806-11	METAL CHIP 56 5% 1/10W	
R325	1-216-836-11	METAL CHIP 18K 5% 1/10W		R595	1-218-938-11	RES-CHIP 56 5% 1/16W	
R326	1-216-829-11	METAL CHIP 4.7K 5% 1/10W		R597	1-216-807-11	METAL CHIP 68 5% 1/10W	
R327	1-216-833-11	METAL CHIP 10K 5% 1/10W		R598	1-216-807-11	METAL CHIP 68 5% 1/10W	
R331	1-216-827-11	METAL CHIP 3.3K 5% 1/10W		R604	1-216-864-11	SHORT CHIP 0	
R333	1-216-809-11	METAL CHIP 100 5% 1/10W		R605	1-216-864-11	SHORT CHIP 0	
R336	1-216-864-11	SHORT CHIP 0		R606	1-216-864-11	SHORT CHIP 0	
R337	1-216-864-11	SHORT CHIP 0		R607	1-216-864-11	SHORT CHIP 0	
				R608	1-216-805-11	METAL CHIP 47 5% 1/10W	
				R609	1-216-805-11	METAL CHIP 47 5% 1/10W	
				R610	1-216-805-11	METAL CHIP 47 5% 1/10W	
				R616	1-216-805-11	METAL CHIP 47 5% 1/10W	
				R617	1-216-806-11	METAL CHIP 56 5% 1/10W	
				R618	1-216-806-11	METAL CHIP 56 5% 1/10W	
				R619	1-216-806-11	METAL CHIP 56 5% 1/10W	
				R620	1-216-806-11	METAL CHIP 56 5% 1/10W	
				R621	1-216-837-11	METAL CHIP 22K 5% 1/10W	
				R622	1-216-837-11	METAL CHIP 22K 5% 1/10W	

Ref. No.	Part No.	Description	Remarks	Ref. No.	Part No.	Description	Remarks	
R641	1-234-400-21	CONDUCTOR, NETWORK	(1005X4)	R3011	1-216-864-11	SHORT CHIP	0 (HXD795/HXD895/HXD995/HXD1095)	
R642	1-216-864-11	SHORT CHIP	0	R3012	1-218-965-11	RES-CHIP	10K 5% 1/16W (HXD795/HXD895/HXD995/HXD1095)	
R660	1-218-847-11	METAL CHIP	1K 0.5%	1/10W	R3013	1-218-937-11	RES-CHIP	47 5% 1/16W (HXD795/HXD895/HXD995/HXD1095)
R661	1-218-847-11	METAL CHIP	1K 0.5%	1/10W	R3014	1-218-965-11	RES-CHIP	10K 5% 1/16W (HXD795/HXD895/HXD995/HXD1095)
R662	1-216-864-11	SHORT CHIP	0	R3015	1-234-400-21	CONDUCTOR, NETWORK	(1005X4) (HXD795/HXD895/HXD995/HXD1095)	
R668	1-216-864-11	SHORT CHIP	0	R3016	1-234-400-21	CONDUCTOR, NETWORK	(1005X4) (HXD795/HXD895/HXD995/HXD1095)	
R672	1-216-818-11	METAL CHIP	560 5%	1/10W	R3017	1-218-990-81	SHORT CHIP	0 (HXD795/HXD895/HXD995/HXD1095)
R678	1-234-723-11	RES, NETWORK	75 (1005X4)	R3019	1-218-937-11	RES-CHIP	47 5% 1/16W (HXD795/HXD895/HXD995/HXD1095)	
R679	1-234-723-11	RES, NETWORK	75 (1005X4)	R3023	1-234-371-21	RES, NETWORK	47 (1005X4) (HXD795/HXD895/HXD995/HXD1095)	
R680	1-216-803-11	METAL CHIP	33 5%	1/10W	R3024	1-218-965-11	RES-CHIP	10K 5% 1/16W (HXD795/HXD895/HXD995/HXD1095)
R681	1-216-803-11	METAL CHIP	33 5%	1/10W	R3025	1-234-371-21	RES, NETWORK	47 (1005X4) (HXD795/HXD895/HXD995/HXD1095)
R682	1-216-803-11	METAL CHIP	33 5%	1/10W	R3026	1-234-370-21	RES, NETWORK	22 (1005X4) (HXD795/HXD895/HXD995/HXD1095)
R685	1-216-833-11	METAL CHIP	10K 5%	1/10W	R3034	1-234-371-21	RES, NETWORK	47 (1005X4) (HXD795/HXD895/HXD995/HXD1095)
R686	1-216-833-11	METAL CHIP	10K 5%	1/10W	R3035	1-234-371-21	RES, NETWORK	47 (1005X4) (HXD795/HXD895/HXD995/HXD1095)
R687	1-216-816-11	METAL CHIP	390 5%	1/10W	R3036	1-234-371-21	RES, NETWORK	47 (1005X4) (HXD795/HXD895/HXD995/HXD1095)
R689	1-216-864-11	SHORT CHIP	0	R3037	1-234-371-21	RES, NETWORK	47 (1005X4) (HXD795/HXD895/HXD995/HXD1095)	
R690	1-216-864-11	SHORT CHIP	0	R3038	1-234-400-21	CONDUCTOR, NETWORK	(1005X4) (HXD795/HXD895/HXD995/HXD1095)	
R691	1-216-864-11	SHORT CHIP	0	R3039	1-234-400-21	CONDUCTOR, NETWORK	(1005X4) (HXD795/HXD895/HXD995/HXD1095)	
R692	1-216-864-11	SHORT CHIP	0	R3040	1-234-371-21	RES, NETWORK	47 (1005X4) (HXD795/HXD895/HXD995/HXD1095)	
R693	1-216-864-11	SHORT CHIP	0	R3041	1-234-371-21	RES, NETWORK	47 (1005X4) (HXD795/HXD895/HXD995/HXD1095)	
R694	1-242-963-21	RES, NETWORK	33 (1005X4)	R3042	1-234-371-21	RES, NETWORK	47 (1005X4) (HXD795/HXD895/HXD995/HXD1095)	
R695	1-242-963-21	RES, NETWORK	33 (1005X4)	R3043	1-234-371-21	RES, NETWORK	47 (1005X4) (HXD795/HXD895/HXD995/HXD1095)	
R696	1-242-963-21	RES, NETWORK	33 (1005X4)	R3044	1-234-400-21	CONDUCTOR, NETWORK	(1005X4) (HXD795/HXD895/HXD995/HXD1095)	
R698	1-218-935-11	RES-CHIP	33 5%	1/16W	R3045	1-234-400-21	CONDUCTOR, NETWORK	(1005X4) (HXD795/HXD895/HXD995/HXD1095)
R699	1-218-935-11	RES-CHIP	33 5%	1/16W	R3046	1-218-935-11	RES-CHIP	33 5% 1/16W (HXD795/HXD895/HXD995/HXD1095)
R700	1-218-935-11	RES-CHIP	33 5%	1/16W	R3047	1-218-935-11	RES-CHIP	33 5% 1/16W (HXD795/HXD895/HXD995/HXD1095)
R701	1-218-935-11	RES-CHIP	33 5%	1/16W	R3048	1-218-935-11	RES-CHIP	33 5% 1/16W (HXD795/HXD895/HXD995/HXD1095)
R702	1-218-935-11	RES-CHIP	33 5%	1/16W	R3049	1-218-935-11	RES-CHIP	33 5% 1/16W (HXD795/HXD895/HXD995/HXD1095)
R704	1-218-935-11	RES-CHIP	33 5%	1/16W	R3050	1-218-935-11	RES-CHIP	33 5% 1/16W (HXD795/HXD895/HXD995/HXD1095)
R705	1-218-935-11	RES-CHIP	33 5%	1/16W	R3051	1-218-935-11	RES-CHIP	33 5% 1/16W (HXD795/HXD895/HXD995/HXD1095)
R706	1-218-935-11	RES-CHIP	33 5%	1/16W				
R707	1-218-935-11	RES-CHIP	33 5%	1/16W				
R801	1-218-953-11	RES-CHIP	1K 5%	1/16W				
R802	1-218-951-11	RES-CHIP	680 5%	1/16W				
R803	1-218-953-11	RES-CHIP	1K 5%	1/16W				
R804	1-218-951-11	RES-CHIP	680 5%	1/16W				
R805	1-218-965-11	RES-CHIP	10K 5%	1/16W				
R806	1-218-965-11	RES-CHIP	10K 5%	1/16W				
R807	1-218-965-11	RES-CHIP	10K 5%	1/16W				
R808	1-218-965-11	RES-CHIP	10K 5%	1/16W				
R809	1-218-953-11	RES-CHIP	1K 5%	1/16W				
R810	1-218-953-11	RES-CHIP	1K 5%	1/16W				
R811	1-218-953-11	RES-CHIP	1K 5%	1/16W				
R812	1-218-953-11	RES-CHIP	1K 5%	1/16W				
R813	1-218-839-11	METAL CHIP	470 0.5%	1/10W				
R814	1-218-839-11	METAL CHIP	470 0.5%	1/10W				
R1057	1-216-864-11	SHORT CHIP	0					
R3001	1-234-378-21	RES, NETWORK	10K (1005X4)					
R3002	1-234-378-21	RES, NETWORK	10K (1005X4)					
R3003	1-234-378-21	RES, NETWORK	10K (1005X4)					
R3004	1-234-371-21	RES, NETWORK	47 (1005X4) (HXD795/HXD895/HXD995/HXD1095)					
R3005	1-234-370-21	RES, NETWORK	22 (1005X4) (HXD795/HXD895/HXD995/HXD1095)					
R3006	1-234-370-21	RES, NETWORK	22 (1005X4) (HXD795/HXD895/HXD995/HXD1095)					
R3007	1-234-370-21	RES, NETWORK	22 (1005X4) (HXD795/HXD895/HXD995/HXD1095)					
R3009	1-234-371-21	RES, NETWORK	47 (1005X4) (HXD795/HXD895/HXD995/HXD1095)					

DT-124

Ref. No.	Part No.	Description	Remarks
R3052	1-218-935-11	RES-CHIP 33 5% 1/16W (HXD795/HXD895/HXD995/HXD1095)	
R3053	1-218-935-11	RES-CHIP 33 5% 1/16W (HXD795/HXD895/HXD995/HXD1095)	
R3054	1-218-965-11	RES-CHIP 10K 5% 1/16W (HXD795/HXD895/HXD995/HXD1095)	
R3055	1-216-833-11	METAL CHIP 10K 5% 1/10W	
R3056	1-234-373-21	RES, NETWORK 220 (1005X4) (HXD790/HXD890/HXD990/HXD1090)	
R3057	1-234-373-21	RES, NETWORK 220 (1005X4) (HXD790/HXD890/HXD990/HXD1090)	
R3059	1-218-965-11	RES-CHIP 10K 5% 1/16W (HXD795/HXD895/HXD995/HXD1095)	
R3060	1-218-965-11	RES-CHIP 10K 5% 1/16W (HXD795/HXD895/HXD995/HXD1095)	
R3061	1-218-937-11	RES-CHIP 47 5% 1/16W (HXD795/HXD895/HXD995/HXD1095)	
R3062	1-218-937-11	RES-CHIP 47 5% 1/16W (HXD795/HXD895/HXD995/HXD1095)	
R3063	1-218-937-11	RES-CHIP 47 5% 1/16W (HXD795/HXD895/HXD995/HXD1095)	
R3064	1-218-937-11	RES-CHIP 47 5% 1/16W (HXD795/HXD895/HXD995/HXD1095)	
R3065	1-218-937-11	RES-CHIP 47 5% 1/16W (HXD795/HXD895/HXD995/HXD1095)	
R3066	1-218-937-11	RES-CHIP 47 5% 1/16W (HXD795/HXD895/HXD995/HXD1095)	
R3067	1-218-937-11	RES-CHIP 47 5% 1/16W (HXD795/HXD895/HXD995/HXD1095)	
R3070	1-218-937-11	RES-CHIP 47 5% 1/16W (HXD795/HXD895/HXD995/HXD1095)	
R3071	1-218-937-11	RES-CHIP 47 5% 1/16W (HXD795/HXD895/HXD995/HXD1095)	
R3072	1-218-937-11	RES-CHIP 47 5% 1/16W (HXD795/HXD895/HXD995/HXD1095)	
R3073	1-218-937-11	RES-CHIP 47 5% 1/16W (HXD795/HXD895/HXD995/HXD1095)	
R3074	1-218-933-11	RES-CHIP 22 5% 1/16W (HXD795/HXD895/HXD995/HXD1095)	
R3075	1-218-933-11	RES-CHIP 22 5% 1/16W (HXD795/HXD895/HXD995/HXD1095)	
R3076	1-218-933-11	RES-CHIP 22 5% 1/16W (HXD795/HXD895/HXD995/HXD1095)	
R3077	1-218-933-11	RES-CHIP 22 5% 1/16W (HXD795/HXD895/HXD995/HXD1095)	
R3078	1-218-943-11	RES-CHIP 150 5% 1/16W (HXD795/HXD895/HXD995/HXD1095)	
R3079	1-218-943-11	RES-CHIP 150 5% 1/16W (HXD795/HXD895/HXD995/HXD1095)	
R3080	1-218-943-11	RES-CHIP 150 5% 1/16W (HXD795/HXD895/HXD995/HXD1095)	
R3081	1-218-943-11	RES-CHIP 150 5% 1/16W (HXD795/HXD895/HXD995/HXD1095)	
R3082	1-218-937-11	RES-CHIP 47 5% 1/16W (HXD795/HXD895/HXD995/HXD1095)	
R3083	1-218-937-11	RES-CHIP 47 5% 1/16W (HXD795/HXD895/HXD995/HXD1095)	
R3084	1-218-937-11	RES-CHIP 47 5% 1/16W (HXD795/HXD895/HXD995/HXD1095)	

Ref. No.	Part No.	Description	Remarks
R3085	1-218-937-11	RES-CHIP 47 5% 1/16W (HXD795/HXD895/HXD995/HXD1095)	
R3086	1-218-933-11	RES-CHIP 22 5% 1/16W (HXD795/HXD895/HXD995/HXD1095)	
R3087	1-218-933-11	RES-CHIP 22 5% 1/16W (HXD795/HXD895/HXD995/HXD1095)	
R3088	1-218-933-11	RES-CHIP 22 5% 1/16W (HXD795/HXD895/HXD995/HXD1095)	
R3089	1-218-933-11	RES-CHIP 22 5% 1/16W (HXD795/HXD895/HXD995/HXD1095)	
R3090	1-218-943-11	RES-CHIP 150 5% 1/16W (HXD795/HXD895/HXD995/HXD1095)	
R3091	1-218-943-11	RES-CHIP 150 5% 1/16W (HXD795/HXD895/HXD995/HXD1095)	
R3092	1-218-943-11	RES-CHIP 150 5% 1/16W (HXD795/HXD895/HXD995/HXD1095)	
R3093	1-218-943-11	RES-CHIP 150 5% 1/16W (HXD795/HXD895/HXD995/HXD1095)	
R3094	1-218-937-11	RES-CHIP 47 5% 1/16W (HXD795/HXD895/HXD995/HXD1095)	
R3095	1-218-937-11	RES-CHIP 47 5% 1/16W (HXD795/HXD895/HXD995/HXD1095)	
R3096	1-218-937-11	RES-CHIP 47 5% 1/16W (HXD795/HXD895/HXD995/HXD1095)	
R3097	1-218-933-11	RES-CHIP 22 5% 1/16W (HXD795/HXD895/HXD995/HXD1095)	
R3098	1-218-933-11	RES-CHIP 22 5% 1/16W (HXD795/HXD895/HXD995/HXD1095)	
R3099	1-218-933-11	RES-CHIP 22 5% 1/16W (HXD795/HXD895/HXD995/HXD1095)	
R3100	1-218-943-11	RES-CHIP 150 5% 1/16W (HXD795/HXD895/HXD995/HXD1095)	
R3101	1-218-943-11	RES-CHIP 150 5% 1/16W (HXD795/HXD895/HXD995/HXD1095)	
R3102	1-218-943-11	RES-CHIP 150 5% 1/16W (HXD795/HXD895/HXD995/HXD1095)	
R3103	1-218-990-81	SHORT CHIP 0 (HXD790/HXD890/XD990/HXD1090)	
R3104	1-218-990-81	SHORT CHIP 0 (HXD790/HXD890/HXD990/HXD1090)	
R3105	1-218-990-81	SHORT CHIP 0 (HXD790/HXD890/HXD990/HXD1090)	
R3106	1-218-937-11	RES-CHIP 47 5% 1/16W (HXD795/HXD895/HXD995/HXD1095)	
R3107	1-218-937-11	RES-CHIP 47 5% 1/16W (HXD795/HXD895/HXD995/HXD1095)	
R3108	1-216-833-11	METAL CHIP 10K 5% 1/10W	
R3110	1-216-864-11	SHORT CHIP 0	
R3111	1-216-809-11	METAL CHIP 100 5% 1/10W	
R3112	1-216-833-11	METAL CHIP 10K 5% 1/10W	
R3114	1-216-864-11	SHORT CHIP 0	
R3115	1-216-864-11	SHORT CHIP 0	
R3116	1-216-864-11	SHORT CHIP 0	
R3117	1-216-864-11	SHORT CHIP 0	
R3118	1-216-825-11	METAL CHIP 2.2K 5% 1/10W (HXD795/HXD895/HXD995/HXD1095)	
R3119	1-216-829-11	METAL CHIP 4.7K 5% 1/10W (HXD795/HXD895/HXD995/HXD1095)	
R3120	1-216-833-11	METAL CHIP 10K 5% 1/10W (HXD795/HXD895/HXD995/HXD1095)	
R3121	1-216-821-11	METAL CHIP 1K 5% 1/10W (HXD795/HXD895/HXD995/HXD1095)	

Ref. No.	Part No.	Description	Remarks	Ref. No.	Part No.	Description	Remarks
R3122	1-216-825-11	METAL CHIP 2.2K 5% 1/10W (HXD795/HXD895/HXD995/HXD1095)				< VARISTOR >	
R3123	1-218-937-11	RES-CHIP 47 5% 1/16W (HXD795/HXD895/HXD995/HXD1095)		VDR102	1-802-071-21	VARISTOR, CHIP	
R3124	1-218-937-11	RES-CHIP 47 5% 1/16W (HXD795/HXD895/HXD995/HXD1095)		VDR104	1-802-071-21	VARISTOR, CHIP	
		< TUNER >		*****			
△ U301	1-693-772-11	TUNER (TDQD5) (AEP, UK)		A-1520-888-A	FR-291 (AG) BOARD, COMPLETE (AEP, UK)		
△ U301	1-693-772-21	TUNER (TDQD5) (AUS)		A-1543-615-A	FR-291 (AS) BOARD, COMPLETE (AUS) (REF. NO.: 30,000 SERIES)		
		< VIBRATOR >		*****			
* X300	1-813-966-21	VIBRATOR, CRYSTAL (SMD, 20.000MH) (20MHz)		*	2-319-520-01	SPACER, FL (AEP, UK)	
				*	2-319-520-11	SPACER, FL (AUS)	
		< CAPACITOR >					
*****				C201	1-117-681-11	ELECT CHIP 100uF 20% 16V	
A-1520-886-A	FL-184 (AG) BOARD, COMPLETE (AEP, UK)			C204	1-164-230-11	CERAMIC CHIP 220PF 5% 50V	
A-1543-613-A	FL-184 (AS) BOARD, COMPLETE (AUS) (REF. NO.: 30,000 SERIES)			C206	1-164-230-11	CERAMIC CHIP 220PF 5% 50V	
	*****			C211	1-107-826-11	CERAMIC CHIP 0.1uF 10% 16V	
	< CAPACITOR >			C213	1-165-621-91	CERAMIC CHIP 0.1uF 50V	
C101	1-115-156-11	CERAMIC CHIP 1uF 10V		C215	1-115-339-11	CERAMIC CHIP 0.1uF 10% 50V	
C102	1-115-156-11	CERAMIC CHIP 1uF 10V		C216	1-126-400-11	ELECT CHIP 22uF 20% 35V	
C107	1-107-726-91	CERAMIC CHIP 0.01uF 10% 16V		C217	1-115-339-11	CERAMIC CHIP 0.1uF 10% 50V	
C111	1-117-681-11	ELECT CHIP 100uF 20% 16V		C221	1-107-726-91	CERAMIC CHIP 0.01uF 10% 16V	
		< CONNECTOR >		C222	1-107-726-91	CERAMIC CHIP 0.01uF 10% 16V	
CN104	1-819-866-11	CONNECTOR, USB (A) (USB A TYPE)		C223	1-115-339-11	CERAMIC CHIP 0.1uF 10% 50V	
CN105	1-817-693-11	CONNECTOR, USB (B) (USB B TYPE)				< CONNECTOR >	
CN106	1-815-381-11	CONNECTOR, FPC/FFC 5P		CN201	1-815-381-11	CONNECTOR, FPC/FFC 5P	
		< CHOKE COIL >		CN202	1-816-497-11	CONNECTOR, FFC/FPC 24P	
FL101	1-456-390-21	COMMOM MODE CHOKE COIL				< DIODE >	
FL102	1-456-390-21	COMMOM MODE CHOKE COIL		D202	8-719-067-40	DIODE STZ6.8N-T146	
		< IC >		D203	8-719-067-40	DIODE STZ6.8N-T146	
IC101	6-600-392-01	IC GP1UM27XK0SF		D204	8-719-067-40	DIODE STZ6.8N-T146	
		< COIL >		D205	8-719-067-40	DIODE STZ6.8N-T146	
L102	1-400-180-21	INDUCTOR, EMI FERRITE (1608)		D206	8-719-067-40	DIODE STZ6.8N-T146	
L103	1-400-180-21	INDUCTOR, EMI FERRITE (1608)		D207	8-719-067-40	DIODE STZ6.8N-T146	
L104	1-400-180-21	INDUCTOR, EMI FERRITE (1608)		D208	8-719-081-97	DIODE MMDL914T1	
L105	1-400-180-21	INDUCTOR, EMI FERRITE (1608)		D209	8-719-081-97	DIODE MMDL914T1	
		< RESISTOR >		D210	8-719-081-97	DIODE MMDL914T1	
R104	1-216-803-11	METAL CHIP 33 5% 1/10W		D211	8-719-081-97	DIODE MMDL914T1	
R105	1-216-803-11	METAL CHIP 33 5% 1/10W		* D212	6-501-884-01	DIODE SDPB31H3C0100	
R108	1-216-803-11	METAL CHIP 33 5% 1/10W		D214	6-501-437-01	DIODE SLI-343YC3F	
R109	1-216-803-11	METAL CHIP 33 5% 1/10W		D216	8-719-056-82	DIODE UDJ-TE-17-6.2B	
R112	1-216-864-11	SHORT CHIP 0				< FERRITE BEAD >	
R113	1-216-864-11	SHORT CHIP 0		FB201	1-414-228-11	INDUCTOR, FERRITE BEAD	
		< SWITCH >		FB202	1-414-228-11	INDUCTOR, FERRITE BEAD	
S101	1-786-726-11	SWITCH, TACTILE (POWER)				< IC >	
S102	1-771-410-21	SWITCH, TACTILE (ONE TOUCH DUB)		IC201	6-701-729-01	IC PT6315	
						< COIL >	
				L201	1-411-919-11	INDUCTOR 100uH	
						< FLUORESCENT INDICATOR TUBE >	
				ND201	1-519-964-11	INDICATOR TUBE, FLUORESCENT	

Note : The components identified by mark △ or dotted line with mark △ are critical for safety. Replace only with part number specified.

Ref. No.	Part No.	Description	Remarks	Ref. No.	Part No.	Description	Remarks	
< TRANSISTOR >				< TRANSFORMER >				
Q201	8-729-052-91	TRANSISTOR	2SD1898T100R	* T201	1-445-207-11	TRANSFORMER, DC-DC CONVERTER		
Q202	8-729-052-91	TRANSISTOR	2SD1898T100R	*****				
Q203	8-729-024-43	TRANSISTOR	2SA1365-T112-1EF	RD-66 (AS) BOARD (REF. NO.: 20,000 SERIES)				
Q204	8-729-421-19	TRANSISTOR	UN2213	*****				
Q205	8-729-029-06	TRANSISTOR	DTC124EUA-T106	< CAPACITOR >				
Q206	8-729-029-10	TRANSISTOR	DTC143TUA-T106	C100	1-164-937-11	CERAMIC CHIP	0.001uF 10% 50V	
< RESISTOR >				C101	1-164-937-11	CERAMIC CHIP	0.001uF 10% 50V	
R201	1-216-295-91	SHORT CHIP	0	C103	1-126-210-21	ELECT CHIP	220uF 20% 4V	
R205	1-216-864-11	SHORT CHIP	0	C104	1-114-130-11	CERAMIC CHIP	1uF 10% 6.3V	
R206	1-216-864-11	SHORT CHIP	0	C105	1-164-937-11	CERAMIC CHIP	0.001uF 10% 50V	
R207	1-216-864-11	SHORT CHIP	0	C107	1-164-936-11	CERAMIC CHIP	680PF 10% 50V	
R209	1-216-833-11	METAL CHIP	10K 5%	1/10W	C115	1-164-943-81	CERAMIC CHIP	0.01uF 10% 16V
R210	1-216-825-11	METAL CHIP	2.2K 5%	1/10W	C116	1-125-777-11	CERAMIC CHIP	0.1uF 10% 10V
R213	1-216-864-11	SHORT CHIP	0	C117	1-164-937-11	CERAMIC CHIP	0.001uF 10% 50V	
R215	1-216-830-11	METAL CHIP	5.6K 5%	1/10W	C120	1-125-777-11	CERAMIC CHIP	0.1uF 10% 10V
R216	1-216-825-11	METAL CHIP	2.2K 5%	1/10W	C121	1-164-939-11	CERAMIC CHIP	0.0022uF 10% 50V
R217	1-216-833-11	METAL CHIP	10K 5%	1/10W	C122	1-164-939-11	CERAMIC CHIP	0.0022uF 10% 50V
R218	1-216-849-11	METAL CHIP	220K 5%	1/10W	C124	1-125-777-11	CERAMIC CHIP	0.1uF 10% 10V
R220	1-216-849-11	METAL CHIP	220K 5%	1/10W	C125	1-114-130-11	CERAMIC CHIP	1uF 10% 6.3V
R222	1-216-295-91	SHORT CHIP	0	C127	1-119-923-11	CERAMIC CHIP	0.047uF 10% 10V	
R223	1-216-826-11	METAL CHIP	2.7K 5%	1/10W	C128	1-125-777-11	CERAMIC CHIP	0.1uF 10% 10V
R225	1-216-814-11	METAL CHIP	270 5%	1/10W	C129	1-114-130-11	CERAMIC CHIP	1uF 10% 6.3V
R227	1-216-838-11	METAL CHIP	27K 5%	1/10W	C130	1-127-760-11	CERAMIC CHIP	4.7uF 10% 6.3V
R228	1-216-833-11	METAL CHIP	10K 5%	1/10W	C131	1-137-987-81	CERAMIC CHIP	0.068uF 10% 10V
R229	1-216-827-11	METAL CHIP	3.3K 5%	1/10W	C133	1-125-777-11	CERAMIC CHIP	0.1uF 10% 10V
R230	1-216-830-11	METAL CHIP	5.6K 5%	1/10W	C134	1-125-777-11	CERAMIC CHIP	0.1uF 10% 10V
R231	1-216-825-11	METAL CHIP	2.2K 5%	1/10W	C135	1-164-943-81	CERAMIC CHIP	0.01uF 10% 16V
R232	1-216-864-11	SHORT CHIP	0	C136	1-125-777-11	CERAMIC CHIP	0.1uF 10% 10V	
R233	1-216-845-11	METAL CHIP	100K 5%	1/10W	C137	1-164-942-11	CERAMIC CHIP	0.0068uF 10% 16V
R235	1-216-864-11	SHORT CHIP	0	C142	1-100-966-91	CERAMIC CHIP	10uF 20% 10V	
R236	1-216-833-11	METAL CHIP	10K 5%	1/10W	C143	1-100-966-91	CERAMIC CHIP	10uF 20% 10V
R237	1-216-833-11	METAL CHIP	10K 5%	1/10W	C144	1-164-943-81	CERAMIC CHIP	0.01uF 10% 16V
R238	1-216-833-11	METAL CHIP	10K 5%	1/10W	C145	1-164-943-81	CERAMIC CHIP	0.01uF 10% 16V
R239	1-216-825-11	METAL CHIP	2.2K 5%	1/10W	C146	1-100-966-91	CERAMIC CHIP	10uF 20% 10V
R240	1-216-825-11	METAL CHIP	2.2K 5%	1/10W	C149	1-164-943-81	CERAMIC CHIP	0.01uF 10% 16V
R241	1-216-827-11	METAL CHIP	3.3K 5%	1/10W	C152	1-164-937-11	CERAMIC CHIP	0.001uF 10% 50V
R242	1-216-825-11	METAL CHIP	2.2K 5%	1/10W	C153	1-124-779-00	ELECT CHIP	10uF 20% 16V
R243	1-216-833-11	METAL CHIP	10K 5%	1/10W	C154	1-114-130-11	CERAMIC CHIP	1uF 10% 6.3V
R244	1-216-825-11	METAL CHIP	2.2K 5%	1/10W	C157	1-164-943-81	CERAMIC CHIP	0.01uF 10% 16V
R245	1-216-827-11	METAL CHIP	3.3K 5%	1/10W	C158	1-164-943-81	CERAMIC CHIP	0.01uF 10% 16V
R246	1-216-830-11	METAL CHIP	5.6K 5%	1/10W	C162	1-114-130-11	CERAMIC CHIP	1uF 10% 6.3V
R250	1-216-805-11	METAL CHIP	47 5%	1/10W	C163	1-126-210-21	ELECT CHIP	220uF 20% 4V
R251	1-216-805-11	METAL CHIP	47 5%	1/10W	C164	1-164-937-11	CERAMIC CHIP	0.001uF 10% 50V
R252	1-216-805-11	METAL CHIP	47 5%	1/10W	C165	1-164-858-11	CERAMIC CHIP	22PF 5% 50V
< SWITCH >				C166	1-164-858-11	CERAMIC CHIP	22PF 5% 50V	
S201	1-786-726-11	SWITCH, TACTILE (REC STOP)		C169	1-125-777-11	CERAMIC CHIP	0.1uF 10% 10V	
S202	1-771-410-21	SWITCH, TACTILE (INPUT SELECT)		C170	1-164-866-11	CERAMIC CHIP	47PF 5% 50V	
S203	1-786-726-11	SWITCH, TACTILE (REC)		C171	1-125-777-11	CERAMIC CHIP	0.1uF 10% 10V	
S204	1-771-410-21	SWITCH, TACTILE (CH+)		C172	1-164-866-11	CERAMIC CHIP	47PF 5% 50V	
S205	1-771-410-21	SWITCH, TACTILE (CH-)		C173	1-164-866-11	CERAMIC CHIP	47PF 5% 50V	
S206	1-786-726-11	SWITCH, TACTILE (STOP)		C174	1-164-866-11	CERAMIC CHIP	47PF 5% 50V	
S207	1-786-726-11	SWITCH, TACTILE (PLAY)		C176	1-164-858-11	CERAMIC CHIP	22PF 5% 50V	
S208	1-786-726-11	SWITCH, TACTILE (DVD)		C177	1-164-858-11	CERAMIC CHIP	22PF 5% 50V	
S209	1-786-726-11	SWITCH, TACTILE (OPEN/CLOSE)		C180	1-100-966-91	CERAMIC CHIP	10uF 20% 10V	
S210	1-786-726-11	SWITCH, TACTILE (HDD)		C181	1-127-760-11	CERAMIC CHIP	4.7uF 10% 6.3V	

Ref. No.	Part No.	Description	Remarks	Ref. No.	Part No.	Description	Remarks
C1401	1-164-943-81	CERAMIC CHIP	0.01uF 10% 16V	C3333	1-114-130-11	CERAMIC CHIP	1uF 10% 6.3V
C1421	1-114-130-11	CERAMIC CHIP	1uF 10% 6.3V	C3334	1-114-130-11	CERAMIC CHIP	1uF 10% 6.3V
C1801	1-114-130-11	CERAMIC CHIP	1uF 10% 6.3V	C3335	1-114-130-11	CERAMIC CHIP	1uF 10% 6.3V
C1802	1-125-889-11	CERAMIC CHIP	2.2uF 10% 10V	C3339	1-114-130-11	CERAMIC CHIP	1uF 10% 6.3V
C1803	1-164-882-11	CERAMIC CHIP	220PF 5% 16V	C3340	1-114-130-11	CERAMIC CHIP	1uF 10% 6.3V
C1804	1-164-934-11	CERAMIC CHIP	330PF 10% 50V	C3341	1-114-130-11	CERAMIC CHIP	1uF 10% 6.3V
C1805	1-119-923-11	CERAMIC CHIP	0.047uF 10% 10V	C3342	1-114-130-11	CERAMIC CHIP	1uF 10% 6.3V
C1811	1-114-130-11	CERAMIC CHIP	1uF 10% 6.3V	C3701	1-164-943-81	CERAMIC CHIP	0.01uF 10% 16V
C1812	1-125-889-11	CERAMIC CHIP	2.2uF 10% 10V	C3703	1-114-130-11	CERAMIC CHIP	1uF 10% 6.3V
C1813	1-164-874-11	CERAMIC CHIP	100PF 5% 50V	C3704	1-100-966-91	CERAMIC CHIP	10uF 20% 10V
C1814	1-164-878-11	CERAMIC CHIP	150PF 5% 50V	C3705	1-164-937-11	CERAMIC CHIP	0.001uF 10% 50V
C1815	1-119-923-11	CERAMIC CHIP	0.047uF 10% 10V	C3706	1-164-937-11	CERAMIC CHIP	0.001uF 10% 50V
C2305	1-114-130-11	CERAMIC CHIP	1uF 10% 6.3V	C3707	1-114-130-11	CERAMIC CHIP	1uF 10% 6.3V
C2501	1-114-130-11	CERAMIC CHIP	1uF 10% 6.3V	C3738	1-114-130-11	CERAMIC CHIP	1uF 10% 6.3V
C2502	1-114-130-11	CERAMIC CHIP	1uF 10% 6.3V	C3801	1-114-130-11	CERAMIC CHIP	1uF 10% 6.3V
C2503	1-114-130-11	CERAMIC CHIP	1uF 10% 6.3V	C3802	1-114-130-11	CERAMIC CHIP	1uF 10% 6.3V
C2504	1-114-130-11	CERAMIC CHIP	1uF 10% 6.3V	C3803	1-114-130-11	CERAMIC CHIP	1uF 10% 6.3V
C2505	1-114-130-11	CERAMIC CHIP	1uF 10% 6.3V	C3804	1-114-130-11	CERAMIC CHIP	1uF 10% 6.3V
C2506	1-100-966-91	CERAMIC CHIP	10uF 20% 10V	C4501	1-114-130-11	CERAMIC CHIP	1uF 10% 6.3V
C3103	1-117-681-11	ELECT CHIP	100uF 20% 16V	C4502	1-114-130-11	CERAMIC CHIP	1uF 10% 6.3V
C3104	1-114-130-11	CERAMIC CHIP	1uF 10% 6.3V	C4503	1-114-130-11	CERAMIC CHIP	1uF 10% 6.3V
C3106	1-164-937-11	CERAMIC CHIP	0.001uF 10% 50V	C4505	1-114-130-11	CERAMIC CHIP	1uF 10% 6.3V
C3107	1-114-130-11	CERAMIC CHIP	1uF 10% 6.3V	C4507	1-117-681-11	ELECT CHIP	100uF 20% 16V
C3108	1-126-210-21	ELECT CHIP	220uF 20% 4V	C4508	1-126-210-21	ELECT CHIP	220uF 20% 4V
C3201	1-126-916-11	ELECT	1000uF 20% 6.3V	C4509	1-126-210-21	ELECT CHIP	220uF 20% 4V
C3203	1-164-937-11	CERAMIC CHIP	0.001uF 10% 50V	C4511	1-127-760-11	CERAMIC CHIP	4.7uF 10% 6.3V
C3204	1-164-934-11	CERAMIC CHIP	330PF 10% 50V	C4513	1-127-760-11	CERAMIC CHIP	4.7uF 10% 6.3V
C3207	1-126-205-11	ELECT CHIP	47uF 20% 6.3V	C4515	1-126-205-11	ELECT CHIP	47uF 20% 6.3V
C3211	1-117-681-11	ELECT CHIP	100uF 20% 16V	C4516	1-124-779-00	ELECT CHIP	10uF 20% 16V
* C3213	1-100-741-81	CERAMIC CHIP	560PF 5% 50V	C4522	1-114-130-11	CERAMIC CHIP	1uF 10% 6.3V
* C3214	1-100-741-81	CERAMIC CHIP	560PF 5% 50V	C4524	1-127-760-11	CERAMIC CHIP	4.7uF 10% 6.3V
C3215	1-164-872-11	CERAMIC CHIP	82PF 5% 50V	C4525	1-127-760-11	CERAMIC CHIP	4.7uF 10% 6.3V
C3216	1-164-872-11	CERAMIC CHIP	82PF 5% 50V	C4526	1-218-967-11	RES-CHIP	15K 5% 1/16W
C3219	1-126-210-21	ELECT CHIP	220uF 20% 4V	C4531	1-114-130-11	CERAMIC CHIP	1uF 10% 6.3V
C3220	1-114-130-11	CERAMIC CHIP	1uF 10% 6.3V	C4532	1-164-943-81	CERAMIC CHIP	0.01uF 10% 16V
C3301	1-162-912-11	CERAMIC CHIP	7PF 0.5PF 50V	C4533	1-114-130-11	CERAMIC CHIP	1uF 10% 6.3V
C3302	1-162-912-11	CERAMIC CHIP	7PF 0.5PF 50V	C4534	1-100-966-91	CERAMIC CHIP	10uF 20% 10V
C3303	1-164-845-11	CERAMIC CHIP	5PF 0.25PF 50V	C4535	1-164-937-11	CERAMIC CHIP	0.001uF 10% 50V
C3304	1-164-870-11	CERAMIC CHIP	68PF 5% 50V	C4536	1-164-937-11	CERAMIC CHIP	0.001uF 10% 50V
C3305	1-164-854-11	CERAMIC CHIP	15PF 5% 50V	C4537	1-164-937-11	CERAMIC CHIP	0.001uF 10% 50V
C3307	1-100-966-91	CERAMIC CHIP	10uF 20% 10V	C4539	1-164-937-11	CERAMIC CHIP	0.001uF 10% 50V
C3311	1-162-912-11	CERAMIC CHIP	7PF 0.5PF 50V	C4540	1-164-937-11	CERAMIC CHIP	0.001uF 10% 50V
C3312	1-162-912-11	CERAMIC CHIP	7PF 0.5PF 50V	C4541	1-114-130-11	CERAMIC CHIP	1uF 10% 6.3V
C3313	1-100-966-91	CERAMIC CHIP	10uF 20% 10V	C4542	1-125-889-11	CERAMIC CHIP	2.2uF 10% 10V
C3314	1-162-912-11	CERAMIC CHIP	7PF 0.5PF 50V	C4543	1-164-937-11	CERAMIC CHIP	0.001uF 10% 50V
C3315	1-162-912-11	CERAMIC CHIP	7PF 0.5PF 50V	C4553	1-162-964-11	CERAMIC CHIP	0.001uF 10% 50V
C3316	1-164-845-11	CERAMIC CHIP	5PF 0.25PF 50V	C4555	1-127-760-11	CERAMIC CHIP	4.7uF 10% 6.3V
C3317	1-164-870-11	CERAMIC CHIP	68PF 5% 50V	C4556	1-127-760-11	CERAMIC CHIP	4.7uF 10% 6.3V
C3318	1-164-854-11	CERAMIC CHIP	15PF 5% 50V	C4557	1-164-943-81	CERAMIC CHIP	0.01uF 10% 16V
C3319	1-100-966-91	CERAMIC CHIP	10uF 20% 10V	C4558	1-117-681-11	ELECT CHIP	100uF 20% 16V
C3320	1-162-912-11	CERAMIC CHIP	7PF 0.5PF 50V	C4559	1-117-681-11	ELECT CHIP	100uF 20% 16V
C3321	1-162-912-11	CERAMIC CHIP	7PF 0.5PF 50V	C4562	1-114-130-11	CERAMIC CHIP	1uF 10% 6.3V
C3322	1-164-845-11	CERAMIC CHIP	5PF 0.25PF 50V	C4563	1-114-130-11	CERAMIC CHIP	1uF 10% 6.3V
C3323	1-164-870-11	CERAMIC CHIP	68PF 5% 50V	C4567	1-114-130-11	CERAMIC CHIP	1uF 10% 6.3V
C3324	1-164-854-11	CERAMIC CHIP	15PF 5% 50V	C4570	1-114-130-11	CERAMIC CHIP	1uF 10% 6.3V
C3325	1-100-966-91	CERAMIC CHIP	10uF 20% 10V	C4571	1-127-760-11	CERAMIC CHIP	4.7uF 10% 6.3V
C3329	1-164-845-11	CERAMIC CHIP	5PF 0.25PF 50V	C4572	1-126-210-21	ELECT CHIP	220uF 20% 4V
C3330	1-164-870-11	CERAMIC CHIP	68PF 5% 50V	C4573	1-127-760-11	CERAMIC CHIP	4.7uF 10% 6.3V
C3331	1-164-854-11	CERAMIC CHIP	15PF 5% 50V	C5105	1-114-130-11	CERAMIC CHIP	1uF 10% 6.3V
C3332	1-114-130-11	CERAMIC CHIP	1uF 10% 6.3V	C5106	1-114-130-11	CERAMIC CHIP	1uF 10% 6.3V

Ref. No.	Part No.	Description	Remarks	Ref. No.	Part No.	Description	Remarks
C5107	1-114-130-11	CERAMIC CHIP	1uF 10% 6.3V	C5803	1-114-130-11	CERAMIC CHIP	1uF 10% 6.3V
C5108	1-114-130-11	CERAMIC CHIP	1uF 10% 6.3V	C5804	1-164-937-11	CERAMIC CHIP	0.001uF 10% 50V
C5110	1-114-130-11	CERAMIC CHIP	1uF 10% 6.3V	C5805	1-114-130-11	CERAMIC CHIP	1uF 10% 6.3V
C5111	1-114-130-11	CERAMIC CHIP	1uF 10% 6.3V	C5806	1-114-130-11	CERAMIC CHIP	1uF 10% 6.3V
C5112	1-114-130-11	CERAMIC CHIP	1uF 10% 6.3V	C5807	1-114-130-11	CERAMIC CHIP	1uF 10% 6.3V
C5115	1-114-130-11	CERAMIC CHIP	1uF 10% 6.3V	C5808	1-114-130-11	CERAMIC CHIP	1uF 10% 6.3V
C5116	1-114-130-11	CERAMIC CHIP	1uF 10% 6.3V	C5809	1-126-210-21	ELECT CHIP	220uF 20% 4V
C5117	1-164-852-11	CERAMIC CHIP	12PF 5% 50V	C5814	1-164-360-11	CERAMIC CHIP	0.1uF 16V
C5118	1-164-852-11	CERAMIC CHIP	12PF 5% 50V	C5815	1-100-566-91	CERAMIC CHIP	0.1uF 10% 25V
C5119	1-100-574-81	CERAMIC CHIP	270PF 10% 50V	C5816	1-100-566-91	CERAMIC CHIP	0.1uF 10% 25V
C5120	1-114-130-11	CERAMIC CHIP	1uF 10% 6.3V	C5817	1-100-566-91	CERAMIC CHIP	0.1uF 10% 25V
C5121	1-126-209-11	ELECT CHIP	100uF 20% 4V	C5818	1-100-566-91	CERAMIC CHIP	0.1uF 10% 25V
C5122	1-126-209-11	ELECT CHIP	100uF 20% 4V	C5819	1-164-937-11	CERAMIC CHIP	0.001uF 10% 50V
C5123	1-114-130-11	CERAMIC CHIP	1uF 10% 6.3V	C5820	1-114-130-11	CERAMIC CHIP	1uF 10% 6.3V
C5132	1-114-130-11	CERAMIC CHIP	1uF 10% 6.3V	C5821	1-164-937-11	CERAMIC CHIP	0.001uF 10% 50V
C5133	1-114-130-11	CERAMIC CHIP	1uF 10% 6.3V	C5822	1-164-937-11	CERAMIC CHIP	0.001uF 10% 50V
C5205	1-114-130-11	CERAMIC CHIP	1uF 10% 6.3V	C5830	1-164-937-11	CERAMIC CHIP	0.001uF 10% 50V
C5210	1-117-681-11	ELECT CHIP	100uF 20% 16V	C5831	1-114-130-11	CERAMIC CHIP	1uF 10% 6.3V
C5211	1-164-937-11	CERAMIC CHIP	0.001uF 10% 50V	C5832	1-164-937-11	CERAMIC CHIP	0.001uF 10% 50V
C5213	1-114-130-11	CERAMIC CHIP	1uF 10% 6.3V	C5833	1-114-130-11	CERAMIC CHIP	1uF 10% 6.3V
C5216	1-164-937-11	CERAMIC CHIP	0.001uF 10% 50V	< CONNECTOR >			
C5219	1-164-937-11	CERAMIC CHIP	0.001uF 10% 50V	CN501	1-766-767-51	CONNECTOR, FPC 12P	
C5223	1-164-937-11	CERAMIC CHIP	0.001uF 10% 50V	CN601	1-784-857-51	CONNECTOR, FFC (LIF (NON-ZIF)) 5P	
C5601	1-114-130-11	CERAMIC CHIP	1uF 10% 6.3V	CN1402	1-764-177-11	PIN, CONNECTOR (SMD) (1.5MM) 7P	
C5602	1-114-130-11	CERAMIC CHIP	1uF 10% 6.3V	* CN4501	1-564-729-11	PIN, CONNECTOR (SMALL TYPE) 13P	
C5604	1-164-943-81	CERAMIC CHIP	0.01uF 10% 16V	CN5101	1-819-414-11	PIN, CONNECTOR (1.5MM) 6P	
C5605	1-164-943-81	CERAMIC CHIP	0.01uF 10% 16V	CN5201	1-820-176-11	PIN, CONNECTOR (1.5MM) 10P	
C5606	1-164-943-81	CERAMIC CHIP	0.01uF 10% 16V	< DIODE >			
C5607	1-164-943-81	CERAMIC CHIP	0.01uF 10% 16V	D1401	8-719-081-42	DIODE UMZ6.8N-T106	
C5608	1-164-943-81	CERAMIC CHIP	0.01uF 10% 16V	D3201	8-719-941-86	DIODE DAN202U	
C5609	1-164-943-81	CERAMIC CHIP	0.01uF 10% 16V	D4521	8-719-058-24	DIODE RB501V-40TE-17	
C5610	1-164-943-81	CERAMIC CHIP	0.01uF 10% 16V	D4552	8-719-058-24	DIODE RB501V-40TE-17	
C5611	1-164-943-81	CERAMIC CHIP	0.01uF 10% 16V	D4571	8-719-058-24	DIODE RB501V-40TE-17	
C5612	1-125-777-11	CERAMIC CHIP	0.1uF 10% 10V	< IC >			
C5613	1-126-209-11	ELECT CHIP	100uF 20% 4V	IC201	6-712-191-01	IC W9864G6GH-6-ER10 (T&R)	
C5614	1-164-943-81	CERAMIC CHIP	0.01uF 10% 16V	IC1201	6-708-812-01	IC HYB25DC512160CE-6	
C5615	1-125-777-11	CERAMIC CHIP	0.1uF 10% 10V	IC1221	6-708-812-01	IC HYB25DC512160CE-6	
C5616	1-125-777-11	CERAMIC CHIP	0.1uF 10% 10V	IC3202	8-759-100-96	IC uPC4558G2	
C5617	1-164-943-81	CERAMIC CHIP	0.01uF 10% 16V	IC3701	8-759-679-05	IC TC7WH34FU (TE12R)	
C5622	1-164-943-81	CERAMIC CHIP	0.01uF 10% 16V	IC3702	6-706-487-01	IC TC7SH08FU (T5RSOYJF)	
C5623	1-164-943-81	CERAMIC CHIP	0.01uF 10% 16V	IC3707	6-707-472-01	IC PST3813UL	
C5624	1-164-943-81	CERAMIC CHIP	0.01uF 10% 16V	IC4541	6-702-362-01	IC MM1563DFBE	
C5625	1-164-943-81	CERAMIC CHIP	0.01uF 10% 16V	IC4561	6-711-116-01	IC NJM2878F3-05 (TE2)	
C5626	1-164-943-81	CERAMIC CHIP	0.01uF 10% 16V	IC4562	6-711-237-01	IC NJM2878F3-33 (TE2)	
C5627	1-164-943-81	CERAMIC CHIP	0.01uF 10% 16V	IC5103	6-706-365-01	IC uPD72852AGB-8EU-A	
C5628	1-164-943-81	CERAMIC CHIP	0.01uF 10% 16V	IC5203	6-706-487-01	IC TC7SH08FU (T5RSOYJF)	
C5629	1-164-943-81	CERAMIC CHIP	0.01uF 10% 16V	IC5602	6-806-103-01	IC 88SA8040-TBC1C000	
C5630	1-164-943-81	CERAMIC CHIP	0.01uF 10% 16V	IC5701	6-707-858-01	IC TC74VHC00FT (EKJ)	
C5631	1-164-943-81	CERAMIC CHIP	0.01uF 10% 16V	IC5804	8-759-680-49	IC TC7WB125FK (TE85R)	
C5632	1-164-943-81	CERAMIC CHIP	0.01uF 10% 16V	< JACK >			
C5640	1-164-854-11	CERAMIC CHIP	15PF 5% 50V	JA5701	1-793-446-21	JACK, PIN 1P (DIGITAL OUT)	
C5641	1-164-854-11	CERAMIC CHIP	15PF 5% 50V	JA5801	1-821-450-12	CONNECTOR, HDMI	
C5702	1-114-130-11	CERAMIC CHIP	1uF 10% 6.3V				
C5705	1-164-937-11	CERAMIC CHIP	0.001uF 10% 50V				
C5706	1-164-937-11	CERAMIC CHIP	0.001uF 10% 50V				
C5707	1-114-130-11	CERAMIC CHIP	1uF 10% 6.3V				
C5708	1-126-210-21	ELECT CHIP	220uF 20% 4V				
C5709	1-165-908-11	CERAMIC CHIP	1uF 10% 10V				
C5801	1-114-130-11	CERAMIC CHIP	1uF 10% 6.3V				
C5802	1-164-937-11	CERAMIC CHIP	0.001uF 10% 50V				

Ref. No.	Part No.	Description	Remarks	Ref. No.	Part No.	Description	Remarks
		< COIL >		R116	1-218-959-11	RES-CHIP	3.3K 5% 1/16W
L105	1-469-967-21	INDUCTOR	10uH	R117	1-218-939-11	RES-CHIP	68 5% 1/16W
L1005	1-412-008-31	INDUCTOR	15uH	R119	1-218-990-81	SHORT CHIP	0
L1801	1-412-958-21	INDUCTOR	39uH	R124	1-218-990-81	SHORT CHIP	0
L1811	1-412-953-11	INDUCTOR	15uH	R128	1-218-990-81	SHORT CHIP	0
L3301	1-412-954-11	INDUCTOR	18uH	R129	1-218-990-81	SHORT CHIP	0
L3302	1-412-951-11	INDUCTOR	10uH	R130	1-218-945-11	RES-CHIP	220 5% 1/16W
L3303	1-412-954-11	INDUCTOR	18uH	R131	1-218-945-11	RES-CHIP	220 5% 1/16W
L3304	1-412-951-11	INDUCTOR	10uH	R132	1-218-945-11	RES-CHIP	220 5% 1/16W
L3305	1-412-954-11	INDUCTOR	18uH	R133	1-218-945-11	RES-CHIP	220 5% 1/16W
L3306	1-412-951-11	INDUCTOR	10uH	R134	1-218-973-11	RES-CHIP	47K 5% 1/16W
L3307	1-412-954-11	INDUCTOR	18uH	R135	1-218-945-11	RES-CHIP	220 5% 1/16W
L3308	1-412-951-11	INDUCTOR	10uH	R136	1-218-945-11	RES-CHIP	220 5% 1/16W
L4551	1-469-967-21	INDUCTOR	10uH	R137	1-218-945-11	RES-CHIP	220 5% 1/16W
L5101	1-414-235-22	INDUCTOR, FERRITE BEAD		R138	1-218-973-11	RES-CHIP	47K 5% 1/16W
L5201	1-456-799-11	COIL, COMMON MODE CHOKE		R139	1-218-945-11	RES-CHIP	220 5% 1/16W
L5202	1-456-799-11	COIL, COMMON MODE CHOKE		R165	1-218-952-11	RES-CHIP	820 5% 1/16W
L5701	1-400-330-21	INDUCTOR, FERRITE BEAD (1608)		R166	1-218-952-11	RES-CHIP	820 5% 1/16W
L5801	1-457-374-21	COMMOM MODE CHOKE COIL		R167	1-218-952-11	RES-CHIP	820 5% 1/16W
L5802	1-457-374-21	COMMOM MODE CHOKE COIL		R168	1-218-990-81	SHORT CHIP	0
L5803	1-457-374-21	COMMOM MODE CHOKE COIL		R170	1-218-959-11	RES-CHIP	3.3K 5% 1/16W
L5804	1-457-374-21	COMMOM MODE CHOKE COIL		R171	1-218-959-11	RES-CHIP	3.3K 5% 1/16W
		< TRANSISTOR >		R172	1-218-959-11	RES-CHIP	3.3K 5% 1/16W
Q1801	8-729-026-53	TRANSISTOR	2SA1576A-T106-QR	R174	1-218-863-11	METAL CHIP	4.7K 0.5% 1/10W
Q1811	8-729-026-53	TRANSISTOR	2SA1576A-T106-QR	R192	1-216-833-11	METAL CHIP	10K 5% 1/10W
Q2501	8-729-026-53	TRANSISTOR	2SA1576A-T106-QR	R193	1-218-990-81	SHORT CHIP	0
Q2502	8-729-026-53	TRANSISTOR	2SA1576A-T106-QR	R202	1-218-935-11	RES-CHIP	33 5% 1/16W
Q2503	8-729-026-53	TRANSISTOR	2SA1576A-T106-QR	R203	1-218-935-11	RES-CHIP	33 5% 1/16W
Q2504	8-729-026-53	TRANSISTOR	2SA1576A-T106-QR	R204	1-242-963-21	RES, NETWORK	33 (1005X4)
Q2505	8-729-026-53	TRANSISTOR	2SA1576A-T106-QR	R205	1-242-963-21	RES, NETWORK	33 (1005X4)
Q3301	8-729-026-53	TRANSISTOR	2SA1576A-T106-QR	R206	1-242-963-21	RES, NETWORK	33 (1005X4)
Q3302	8-729-026-53	TRANSISTOR	2SA1576A-T106-QR	R210	1-218-935-11	RES-CHIP	33 5% 1/16W
Q3303	8-729-026-53	TRANSISTOR	2SA1576A-T106-QR	R211	1-218-990-81	SHORT CHIP	0
Q3304	8-729-026-53	TRANSISTOR	2SA1576A-T106-QR	R219	1-234-377-21	RES, NETWORK	4.7K (1005X4)
Q3305	8-729-026-53	TRANSISTOR	2SA1576A-T106-QR	R220	1-234-377-21	RES, NETWORK	4.7K (1005X4)
Q3306	8-729-026-53	TRANSISTOR	2SA1576A-T106-QR	R221	1-218-973-11	RES-CHIP	47K 5% 1/16W
Q3307	8-729-026-53	TRANSISTOR	2SA1576A-T106-QR	R222	1-218-973-11	RES-CHIP	47K 5% 1/16W
Q3308	8-729-026-53	TRANSISTOR	2SA1576A-T106-QR	R223	1-218-933-11	RES-CHIP	22 5% 1/16W
Q5701	8-729-026-53	TRANSISTOR	2SA1576A-T106-QR	R230	1-218-990-81	SHORT CHIP	0
Q5801	6-550-376-01	TRANSISTOR	UMX1N-TN	R233	1-218-990-81	SHORT CHIP	0
Q5804	8-729-029-06	TRANSISTOR	DTC124EUA-T106	R234	1-218-990-81	SHORT CHIP	0
Q5805	8-729-026-53	TRANSISTOR	2SA1576A-T106-QR	R248	1-218-965-11	RES-CHIP	10K 5% 1/16W
Q5808	8-729-031-34	TRANSISTOR	2SK2034	R252	1-218-965-11	RES-CHIP	10K 5% 1/16W
Q5809	8-729-029-06	TRANSISTOR	DTC124EUA-T106	R253	1-218-965-11	RES-CHIP	10K 5% 1/16W
Q5811	8-729-028-83	TRANSISTOR	DTA124EUA-T106	R256	1-218-965-11	RES-CHIP	10K 5% 1/16W
		< RESISTOR >		R257	1-218-965-11	RES-CHIP	10K 5% 1/16W
R104	1-218-966-11	RES-CHIP	12K 5% 1/16W	R271	1-216-295-91	SHORT CHIP	0
R105	1-218-990-81	SHORT CHIP	0	R273	1-216-295-91	SHORT CHIP	0
R107	1-218-973-11	RES-CHIP	47K 5% 1/16W	R274	1-216-295-91	SHORT CHIP	0
R108	1-218-963-11	RES-CHIP	6.8K 5% 1/16W	R281	1-218-990-81	SHORT CHIP	0
R109	1-208-702-11	METAL CHIP	6.2K 0.5% 1/16W	R301	1-218-973-11	RES-CHIP	47K 5% 1/16W
R110	1-218-953-11	RES-CHIP	1K 5% 1/16W	R306	1-218-957-11	RES-CHIP	2.2K 5% 1/16W
R111	1-218-985-11	RES-CHIP	470K 5% 1/16W	R307	1-218-957-11	RES-CHIP	2.2K 5% 1/16W
R112	1-218-985-11	RES-CHIP	470K 5% 1/16W	R310	1-218-953-11	RES-CHIP	1K 5% 1/16W
R114	1-218-971-11	RES-CHIP	33K 5% 1/16W	R311	1-218-953-11	RES-CHIP	1K 5% 1/16W
R115	1-218-990-81	SHORT CHIP	0	R312	1-218-953-11	RES-CHIP	1K 5% 1/16W
				R313	1-218-973-11	RES-CHIP	47K 5% 1/16W
				R314	1-218-953-11	RES-CHIP	1K 5% 1/16W
				R317	1-242-963-21	RES, NETWORK	33 (1005X4)
				R318	1-242-963-21	RES, NETWORK	33 (1005X4)

Ref. No.	Part No.	Description	Remarks	Ref. No.	Part No.	Description	Remarks	
R319	1-242-963-21	RES, NETWORK	33 (1005X4)	R1197	1-218-961-11	RES-CHIP	4.7K 5% 1/16W	
R320	1-242-963-21	RES, NETWORK	33 (1005X4)	R1199	1-218-965-11	RES-CHIP	10K 5% 1/16W	
R503	1-218-953-11	RES-CHIP	1K 5%	1/16W	R1205	1-218-965-11	RES-CHIP	10K 5% 1/16W
R504	1-218-953-11	RES-CHIP	1K 5%	1/16W	R1219	1-218-990-81	SHORT CHIP	0
R505	1-218-966-11	RES-CHIP	12K 5%	1/16W	R1240	1-218-933-11	RES-CHIP	22 5% 1/16W
R506	1-218-953-11	RES-CHIP	1K 5%	1/16W	R1241	1-234-400-21	CONDUCTOR, NETWORK	(1005X4)
R507	1-218-953-11	RES-CHIP	1K 5%	1/16W	R1242	1-234-400-21	CONDUCTOR, NETWORK	(1005X4)
R510	1-217-907-11	RES-CHIP	1.8 5%	1/10W	R1243	1-218-990-81	SHORT CHIP	0
R511	1-217-907-11	RES-CHIP	1.8 5%	1/10W	R1244	1-218-935-11	RES-CHIP	33 5% 1/16W
R515	1-218-971-11	RES-CHIP	33K 5%	1/16W	R1245	1-234-370-21	RES, NETWORK	22 (1005X4)
R516	1-218-966-11	RES-CHIP	12K 5%	1/16W	R1246	1-234-370-21	RES, NETWORK	22 (1005X4)
R601	1-218-965-11	RES-CHIP	10K 5%	1/16W	R1247	1-218-933-11	RES-CHIP	22 5% 1/16W
R602	1-218-965-11	RES-CHIP	10K 5%	1/16W	R1248	1-234-400-21	CONDUCTOR, NETWORK	(1005X4)
R603	1-218-953-11	RES-CHIP	1K 5%	1/16W	R1249	1-234-400-21	CONDUCTOR, NETWORK	(1005X4)
R604	1-218-953-11	RES-CHIP	1K 5%	1/16W	R1250	1-218-990-81	SHORT CHIP	0
R1001	1-218-965-11	RES-CHIP	10K 5%	1/16W	R1251	1-218-935-11	RES-CHIP	33 5% 1/16W
R1003	1-218-843-11	METAL CHIP	680 0.5%	1/10W	R1252	1-218-935-11	RES-CHIP	33 5% 1/16W
R1004	1-218-839-11	METAL CHIP	470 0.5%	1/10W	R1255	1-234-370-21	RES, NETWORK	22 (1005X4)
R1005	1-218-967-11	RES-CHIP	15K 5%	1/16W	R1256	1-234-370-21	RES, NETWORK	22 (1005X4)
R1006	1-218-967-11	RES-CHIP	15K 5%	1/16W	R1257	1-218-933-11	RES-CHIP	22 5% 1/16W
R1013	1-218-965-11	RES-CHIP	10K 5%	1/16W	R1258	1-218-933-11	RES-CHIP	22 5% 1/16W
R1016	1-218-965-11	RES-CHIP	10K 5%	1/16W	R1260	1-218-933-11	RES-CHIP	22 5% 1/16W
R1017	1-218-990-81	SHORT CHIP	0	R1261	1-234-400-21	CONDUCTOR, NETWORK	(1005X4)	
R1018	1-218-990-81	SHORT CHIP	0	R1262	1-234-400-21	CONDUCTOR, NETWORK	(1005X4)	
R1019	1-218-990-81	SHORT CHIP	0	R1263	1-218-990-81	SHORT CHIP	0	
R1021	1-218-965-11	RES-CHIP	10K 5%	1/16W	R1264	1-218-935-11	RES-CHIP	33 5% 1/16W
R1027	1-218-965-11	RES-CHIP	10K 5%	1/16W	R1265	1-234-370-21	RES, NETWORK	22 (1005X4)
R1028	1-218-965-11	RES-CHIP	10K 5%	1/16W	R1266	1-234-370-21	RES, NETWORK	22 (1005X4)
R1029	1-218-940-11	RES-CHIP	82 5%	1/16W	R1267	1-218-933-11	RES-CHIP	22 5% 1/16W
R1030	1-218-937-11	RES-CHIP	47 5%	1/16W	R1268	1-234-400-21	CONDUCTOR, NETWORK	(1005X4)
R1031	1-218-943-11	RES-CHIP	150 5%	1/16W	R1269	1-234-400-21	CONDUCTOR, NETWORK	(1005X4)
R1032	1-234-378-21	RES, NETWORK	10K (1005X4)	R1270	1-218-990-81	SHORT CHIP	0	
R1033	1-234-378-21	RES, NETWORK	10K (1005X4)	R1271	1-218-935-11	RES-CHIP	33 5% 1/16W	
R1034	1-234-378-21	RES, NETWORK	10K (1005X4)	R1272	1-218-935-11	RES-CHIP	33 5% 1/16W	
R1035	1-234-378-21	RES, NETWORK	10K (1005X4)	R1273	1-234-370-21	RES, NETWORK	22 (1005X4)	
R1036	1-211-984-11	METAL CHIP	43 0.5%	1/10W	R1274	1-234-370-21	RES, NETWORK	22 (1005X4)
R1037	1-218-823-11	METAL CHIP	100 0.5%	1/10W	R1275	1-218-933-11	RES-CHIP	22 5% 1/16W
R1039	1-211-984-11	METAL CHIP	43 0.5%	1/10W	R1276	1-218-933-11	RES-CHIP	22 5% 1/16W
R1040	1-218-823-11	METAL CHIP	100 0.5%	1/10W	R1277	1-218-990-81	SHORT CHIP	0
R1060	1-218-990-81	SHORT CHIP	0	R1278	1-218-990-81	SHORT CHIP	0	
R1061	1-218-990-81	SHORT CHIP	0	R1279	1-218-940-11	RES-CHIP	82 5% 1/16W	
R1062	1-218-990-81	SHORT CHIP	0	R1281	1-234-371-21	RES, NETWORK	47 (1005X4)	
R1063	1-218-990-81	SHORT CHIP	0	R1282	1-234-371-21	RES, NETWORK	47 (1005X4)	
R1067	1-218-973-11	RES-CHIP	47K 5%	1/16W	R1283	1-234-371-21	RES, NETWORK	47 (1005X4)
R1068	1-218-973-11	RES-CHIP	47K 5%	1/16W	R1284	1-218-937-11	RES-CHIP	47 5% 1/16W
R1069	1-218-973-11	RES-CHIP	47K 5%	1/16W	R1285	1-218-937-11	RES-CHIP	47 5% 1/16W
R1071	1-218-965-11	RES-CHIP	10K 5%	1/16W	R1286	1-218-937-11	RES-CHIP	47 5% 1/16W
R1103	1-218-990-81	SHORT CHIP	0	R1287	1-234-371-21	RES, NETWORK	47 (1005X4)	
R1107	1-218-990-81	SHORT CHIP	0	R1288	1-218-933-11	RES-CHIP	22 5% 1/16W	
R1110	1-218-990-81	SHORT CHIP	0	R1289	1-218-933-11	RES-CHIP	22 5% 1/16W	
R1111	1-218-977-11	RES-CHIP	100K 5%	1/16W	R1301	1-218-839-11	METAL CHIP	470 0.5% 1/10W
R1132	1-218-937-11	RES-CHIP	47 5%	1/16W	R1302	1-218-847-11	METAL CHIP	1K 0.5% 1/10W
R1153	1-218-961-11	RES-CHIP	4.7K 5%	1/16W	R1303	1-218-847-11	METAL CHIP	1K 0.5% 1/10W
R1161	1-218-961-11	RES-CHIP	4.7K 5%	1/16W	R1305	1-218-990-81	SHORT CHIP	0
R1163	1-218-961-11	RES-CHIP	4.7K 5%	1/16W	R1312	1-218-847-11	METAL CHIP	1K 0.5% 1/10W
R1165	1-218-961-11	RES-CHIP	4.7K 5%	1/16W	R1313	1-218-847-11	METAL CHIP	1K 0.5% 1/10W
R1181	1-218-965-11	RES-CHIP	10K 5%	1/16W	R1315	1-216-864-11	SHORT CHIP	0
R1182	1-218-965-11	RES-CHIP	10K 5%	1/16W	R1401	1-218-933-11	RES-CHIP	22 5% 1/16W
R1191	1-218-961-11	RES-CHIP	4.7K 5%	1/16W	R1402	1-218-933-11	RES-CHIP	22 5% 1/16W
R1195	1-218-961-11	RES-CHIP	4.7K 5%	1/16W	R1403	1-218-933-11	RES-CHIP	22 5% 1/16W

RD-66

Ref. No.	Part No.	Description	Quantity	Unit	Remarks	Ref. No.	Part No.	Description	Quantity	Unit	Remarks
R1404	1-218-933-11	RES-CHIP	22	5%	1/16W	R3207	1-218-937-11	RES-CHIP	47	5%	1/16W
R1405	1-218-933-11	RES-CHIP	22	5%	1/16W	R3208	1-218-937-11	RES-CHIP	47	5%	1/16W
R1406	1-218-933-11	RES-CHIP	22	5%	1/16W	R3209	1-218-977-11	RES-CHIP	100K	5%	1/16W
R1407	1-218-933-11	RES-CHIP	22	5%	1/16W	R3210	1-218-849-11	METAL CHIP	1.2K	0.5%	1/10W
R1411	1-234-378-21	RES, NETWORK	10K (1005X4)			R3211	1-218-871-11	METAL CHIP	10K	0.5%	1/10W
R1412	1-218-965-11	RES-CHIP	10K	5%	1/16W	R3213	1-218-951-11	RES-CHIP	680	5%	1/16W
R1413	1-218-973-11	RES-CHIP	47K	5%	1/16W	R3214	1-218-963-11	RES-CHIP	6.8K	5%	1/16W
R1414	1-218-933-11	RES-CHIP	22	5%	1/16W	R3215	1-218-969-11	RES-CHIP	22K	5%	1/16W
R1415	1-218-933-11	RES-CHIP	22	5%	1/16W	R3216	1-218-849-11	METAL CHIP	1.2K	0.5%	1/10W
R1416	1-218-933-11	RES-CHIP	22	5%	1/16W	R3217	1-218-871-11	METAL CHIP	10K	0.5%	1/10W
R1421	1-218-965-11	RES-CHIP	10K	5%	1/16W	R3218	1-218-879-11	METAL CHIP	22K	0.5%	1/10W
R1422	1-218-965-11	RES-CHIP	10K	5%	1/16W	R3219	1-218-963-11	RES-CHIP	6.8K	5%	1/16W
R1802	1-218-945-11	RES-CHIP	220	5%	1/16W	R3220	1-218-941-81	RES-CHIP	100	5%	1/16W
R1803	1-218-947-11	RES-CHIP	330	5%	1/16W	R3221	1-218-941-81	RES-CHIP	100	5%	1/16W
R1804	1-218-935-11	RES-CHIP	33	5%	1/16W	R3222	1-218-963-11	RES-CHIP	6.8K	5%	1/16W
R1812	1-218-945-11	RES-CHIP	220	5%	1/16W	R3223	1-218-879-11	METAL CHIP	22K	0.5%	1/10W
R1813	1-218-947-11	RES-CHIP	330	5%	1/16W	R3224	1-218-941-81	RES-CHIP	100	5%	1/16W
R1814	1-218-935-11	RES-CHIP	33	5%	1/16W	R3227	1-218-941-81	RES-CHIP	100	5%	1/16W
R2301	1-218-959-11	RES-CHIP	3.3K	5%	1/16W	R3228	1-218-965-11	RES-CHIP	10K	5%	1/16W
R2302	1-218-990-81	SHORT CHIP	0			R3229	1-218-965-11	RES-CHIP	10K	5%	1/16W
R2304	1-218-990-81	SHORT CHIP	0			R3230	1-216-295-91	SHORT CHIP	0		
R2316	1-218-965-11	RES-CHIP	10K	5%	1/16W	R3232	1-218-990-81	SHORT CHIP	0		
R2501	1-218-951-11	RES-CHIP	680	5%	1/16W	R3233	1-218-990-81	SHORT CHIP	0		
R2502	1-218-827-11	METAL CHIP	150	0.5%	1/10W	R3234	1-218-990-81	SHORT CHIP	0		
R2504	1-218-951-11	RES-CHIP	680	5%	1/16W	R3301	1-218-937-11	RES-CHIP	47	5%	1/16W
R2505	1-218-827-11	METAL CHIP	150	0.5%	1/10W	R3302	1-218-937-11	RES-CHIP	47	5%	1/16W
R2506	1-216-864-11	SHORT CHIP	0			R3305	1-218-947-11	RES-CHIP	330	5%	1/16W
R2507	1-218-951-11	RES-CHIP	680	5%	1/16W	R3306	1-218-839-11	METAL CHIP	470	0.5%	1/10W
R2508	1-218-827-11	METAL CHIP	150	0.5%	1/10W	R3307	1-208-905-11	METAL CHIP	5.6K	0.5%	1/16W
R2510	1-218-951-11	RES-CHIP	680	5%	1/16W	R3308	1-218-929-11	RES-CHIP	10	5%	1/16W
R2511	1-218-827-11	METAL CHIP	150	0.5%	1/10W	R3309	1-218-951-11	RES-CHIP	680	5%	1/16W
R2513	1-218-951-11	RES-CHIP	680	5%	1/16W	R3312	1-218-839-11	METAL CHIP	470	0.5%	1/10W
R2514	1-218-827-11	METAL CHIP	150	0.5%	1/10W	R3313	1-208-905-11	METAL CHIP	5.6K	0.5%	1/16W
R3002	1-218-939-11	RES-CHIP	68	5%	1/16W	R3314	1-218-929-11	RES-CHIP	10	5%	1/16W
R3003	1-218-940-11	RES-CHIP	82	5%	1/16W	R3315	1-218-951-11	RES-CHIP	680	5%	1/16W
R3004	1-218-940-11	RES-CHIP	82	5%	1/16W	R3317	1-218-947-11	RES-CHIP	330	5%	1/16W
R3005	1-234-378-21	RES, NETWORK	10K (1005X4)			R3318	1-218-839-11	METAL CHIP	470	0.5%	1/10W
R3006	1-218-990-81	SHORT CHIP	0			R3319	1-218-929-11	RES-CHIP	10	5%	1/16W
R3007	1-218-990-81	SHORT CHIP	0			R3320	1-218-951-11	RES-CHIP	680	5%	1/16W
R3008	1-218-990-81	SHORT CHIP	0			R3322	1-218-947-11	RES-CHIP	330	5%	1/16W
R3009	1-218-990-81	SHORT CHIP	0			R3323	1-218-839-11	METAL CHIP	470	0.5%	1/10W
R3010	1-218-990-81	SHORT CHIP	0			R3324	1-208-905-11	METAL CHIP	5.6K	0.5%	1/16W
R3011	1-218-990-81	SHORT CHIP	0			R3325	1-208-905-11	METAL CHIP	5.6K	0.5%	1/16W
R3012	1-218-990-81	SHORT CHIP	0			R3326	1-218-929-11	RES-CHIP	10	5%	1/16W
R3101	1-218-990-81	SHORT CHIP	0			R3327	1-218-951-11	RES-CHIP	680	5%	1/16W
R3102	1-218-990-81	SHORT CHIP	0			R3336	1-218-937-11	RES-CHIP	47	5%	1/16W
R3103	1-218-990-81	SHORT CHIP	0			R3341	1-218-937-11	RES-CHIP	47	5%	1/16W
R3104	1-218-990-81	SHORT CHIP	0			R3344	1-218-947-11	RES-CHIP	330	5%	1/16W
R3105	1-218-989-11	RES-CHIP	1M	5%	1/16W	R3703	1-218-941-81	RES-CHIP	100	5%	1/16W
R3106	1-218-965-11	RES-CHIP	10K	5%	1/16W	R3704	1-218-941-81	RES-CHIP	100	5%	1/16W
R3107	1-218-937-11	RES-CHIP	47	5%	1/16W	R3705	1-218-941-81	RES-CHIP	100	5%	1/16W
R3108	1-218-937-11	RES-CHIP	47	5%	1/16W	R3708	1-218-965-11	RES-CHIP	10K	5%	1/16W
R3109	1-218-937-11	RES-CHIP	47	5%	1/16W	R3715	1-218-990-81	SHORT CHIP	0		
R3111	1-218-990-81	SHORT CHIP	0			R3716	1-218-935-11	RES-CHIP	33	5%	1/16W
R3113	1-218-965-11	RES-CHIP	10K	5%	1/16W	R3720	1-218-990-81	SHORT CHIP	0		
R3201	1-218-937-11	RES-CHIP	47	5%	1/16W	R3737	1-218-965-11	RES-CHIP	10K	5%	1/16W
R3202	1-218-937-11	RES-CHIP	47	5%	1/16W	R3738	1-218-965-11	RES-CHIP	10K	5%	1/16W
R3203	1-218-937-11	RES-CHIP	47	5%	1/16W	R3808	1-218-941-81	RES-CHIP	100	5%	1/16W
R3204	1-218-990-81	SHORT CHIP	0			R3810	1-242-963-21	RES, NETWORK	33 (1005X4)		
R3206	1-218-937-11	RES-CHIP	47	5%	1/16W	R3811	1-242-963-21	RES, NETWORK	33 (1005X4)		

Ref. No.	Part No.	Description	Remarks	Ref. No.	Part No.	Description	Remarks
R3812	1-242-963-21	RES, NETWORK	33 (1005X4)	R4708	1-234-378-21	RES, NETWORK	10K (1005X4)
R3813	1-242-963-21	RES, NETWORK	33 (1005X4)	R4709	1-234-378-21	RES, NETWORK	10K (1005X4)
R3814	1-218-933-11	RES-CHIP	22 5%	1/16W	R4710	1-218-965-11	RES-CHIP 10K 5% 1/16W
R3816	1-218-940-11	RES-CHIP	82 5%	1/16W	R4711	1-218-965-11	RES-CHIP 10K 5% 1/16W
R3817	1-218-940-11	RES-CHIP	82 5%	1/16W	R4712	1-218-965-11	RES-CHIP 10K 5% 1/16W
R3818	1-218-933-11	RES-CHIP	22 5%	1/16W	R4713	1-218-965-11	RES-CHIP 10K 5% 1/16W
R3820	1-218-940-11	RES-CHIP	82 5%	1/16W	R4714	1-218-990-81	SHORT CHIP 0
R3821	1-218-933-11	RES-CHIP	22 5%	1/16W	R4721	1-234-400-21	CONDUCTOR, NETWORK (1005X4)
R3823	1-218-940-11	RES-CHIP	82 5%	1/16W	R4722	1-234-400-21	CONDUCTOR, NETWORK (1005X4)
R3824	1-242-962-21	RES, NETWORK	82 (1005X4)	R4723	1-218-990-81	SHORT CHIP 0	
* R3828	1-234-380-21	RES, NETWORK	47K (1005X4)	R4724	1-218-990-81	SHORT CHIP 0	
* R3829	1-234-380-21	RES, NETWORK	47K (1005X4)	R4725	1-218-990-81	SHORT CHIP 0	
* R3830	1-234-380-21	RES, NETWORK	47K (1005X4)	R4726	1-218-990-81	SHORT CHIP 0	
* R3831	1-234-380-21	RES, NETWORK	47K (1005X4)	R4727	1-218-965-11	RES-CHIP 10K 5% 1/16W	
R3832	1-234-379-21	RES, NETWORK	22K (1005X4)	R4728	1-218-965-11	RES-CHIP 10K 5% 1/16W	
R3833	1-234-379-21	RES, NETWORK	22K (1005X4)	R4729	1-218-990-81	SHORT CHIP 0	
R3835	1-218-935-11	RES-CHIP	33 5%	1/16W	R4731	1-218-961-11	RES-CHIP 4.7K 5% 1/16W
R3837	1-242-963-21	RES, NETWORK	33 (1005X4)	R4732	1-218-961-11	RES-CHIP 4.7K 5% 1/16W	
R3838	1-242-963-21	RES, NETWORK	33 (1005X4)	R5101	1-234-381-11	RES, NETWORK 100K (1005X4)	
R3839	1-242-963-21	RES, NETWORK	33 (1005X4)	R5102	1-234-381-11	RES, NETWORK 100K (1005X4)	
R3840	1-242-963-21	RES, NETWORK	33 (1005X4)	R5103	1-218-977-11	RES-CHIP 100K 5% 1/16W	
R3841	1-218-940-11	RES-CHIP	82 5%	1/16W	R5104	1-218-977-11	RES-CHIP 100K 5% 1/16W
R3842	1-218-962-11	RES-CHIP	5.6K 5%	1/16W	R5105	1-234-702-11	RES, NETWORK 68 (1005X4)
R3843	1-218-933-11	RES-CHIP	22 5%	1/16W	R5106	1-234-702-11	RES, NETWORK 68 (1005X4)
R3844	1-218-933-11	RES-CHIP	22 5%	1/16W	R5107	1-218-939-11	RES-CHIP 68 5% 1/16W
R3845	1-218-940-11	RES-CHIP	82 5%	1/16W	R5108	1-218-939-11	RES-CHIP 68 5% 1/16W
R3846	1-218-965-11	RES-CHIP	10K 5%	1/16W	R5109	1-218-937-11	RES-CHIP 47 5% 1/16W
R3847	1-218-933-11	RES-CHIP	22 5%	1/16W	R5110	1-218-965-11	RES-CHIP 10K 5% 1/16W
R3848	1-218-940-11	RES-CHIP	82 5%	1/16W	R5111	1-218-953-11	RES-CHIP 1K 5% 1/16W
R3849	1-218-965-11	RES-CHIP	10K 5%	1/16W	R5113	1-218-965-11	RES-CHIP 10K 5% 1/16W
R3850	1-218-935-11	RES-CHIP	33 5%	1/16W	R5114	1-218-965-11	RES-CHIP 10K 5% 1/16W
R3851	1-242-963-21	RES, NETWORK	33 (1005X4)	R5115	1-218-965-11	RES-CHIP 10K 5% 1/16W	
R3857	1-218-990-81	SHORT CHIP	0	R5116	1-218-965-11	RES-CHIP 10K 5% 1/16W	
R3862	1-218-990-81	SHORT CHIP	0	R5117	1-218-977-11	RES-CHIP 100K 5% 1/16W	
R3871	1-218-969-11	RES-CHIP	22K 5%	1/16W	R5118	1-218-870-11	METAL CHIP 9.1K 0.5% 1/10W
R4501	1-216-295-91	SHORT CHIP	0	R5119	1-211-987-11	METAL CHIP 56 0.5% 1/10W	
R4504	1-216-059-00	RES-CHIP	2.7K 5%	1/10W	R5120	1-211-987-11	METAL CHIP 56 0.5% 1/10W
R4505	1-216-059-00	RES-CHIP	2.7K 5%	1/10W	R5121	1-211-987-11	METAL CHIP 56 0.5% 1/10W
R4507	1-216-059-00	RES-CHIP	2.7K 5%	1/10W	R5122	1-211-987-11	METAL CHIP 56 0.5% 1/10W
R4511	1-218-990-81	SHORT CHIP	0	R5123	1-218-965-11	RES-CHIP 10K 5% 1/16W	
R4521	1-218-963-11	RES-CHIP	6.8K 5%	1/16W	R5124	1-218-965-11	RES-CHIP 10K 5% 1/16W
R4531	1-218-990-81	SHORT CHIP	0	R5125	1-218-953-11	RES-CHIP 1K 5% 1/16W	
R4541	1-218-990-81	SHORT CHIP	0	R5127	1-218-965-11	RES-CHIP 10K 5% 1/16W	
R4552	1-216-295-91	SHORT CHIP	0	R5129	1-218-940-11	RES-CHIP 82 5% 1/16W	
R4553	1-216-295-91	SHORT CHIP	0	R5130	1-218-990-81	SHORT CHIP 0	
R4554	1-216-295-91	SHORT CHIP	0	R5131	1-218-864-11	METAL CHIP 5.1K 0.5% 1/10W	
R4556	1-216-295-91	SHORT CHIP	0	R5132	1-218-990-81	SHORT CHIP 0	
R4558	1-218-969-11	RES-CHIP	22K 5%	1/16W	R5133	1-218-990-81	SHORT CHIP 0
R4559	1-218-990-81	SHORT CHIP	0	R5134	1-218-990-81	SHORT CHIP 0	
R4573	1-218-990-81	SHORT CHIP	0	R5135	1-218-990-81	SHORT CHIP 0	
R4574	1-216-864-11	SHORT CHIP	0	R5140	1-218-965-11	RES-CHIP 10K 5% 1/16W	
R4575	1-216-864-11	SHORT CHIP	0	R5141	1-218-990-81	SHORT CHIP 0	
R4582	1-216-295-91	SHORT CHIP	0	R5201	1-218-990-81	SHORT CHIP 0	
* R4701	1-234-714-11	RES, NETWORK	56 (1005X4)	R5202	1-218-990-81	SHORT CHIP 0	
* R4702	1-234-714-11	RES, NETWORK	56 (1005X4)	R5205	1-218-939-11	RES-CHIP 68 5% 1/16W	
R4703	1-218-929-11	RES-CHIP	10 5%	1/16W	R5207	1-218-990-81	SHORT CHIP 0
R4704	1-218-941-81	RES-CHIP	100 5%	1/16W	R5212	1-218-990-81	SHORT CHIP 0
R4705	1-218-941-81	RES-CHIP	100 5%	1/16W	R5213	1-218-990-81	SHORT CHIP 0
R4706	1-218-935-11	RES-CHIP	33 5%	1/16W	R5214	1-218-973-11	RES-CHIP 47K 5% 1/16W
R4707	1-218-965-11	RES-CHIP	10K 5%	1/16W	R5215	1-218-973-11	RES-CHIP 47K 5% 1/16W

RD-66

Ref. No.	Part No.	Description	Quantity	Power	Remarks	Ref. No.	Part No.	Description	Quantity	Power	Remarks
R5216	1-218-990-81	SHORT CHIP	0			R5806	1-218-953-11	RES-CHIP	1K	5%	1/16W
R5217	1-218-990-81	SHORT CHIP	0			R5807	1-218-962-11	RES-CHIP	5.6K	5%	1/16W
R5220	1-218-851-11	METAL CHIP	1.5K	0.5%	1/10W	R5808	1-218-961-11	RES-CHIP	4.7K	5%	1/16W
R5221	1-218-973-11	RES-CHIP	47K	5%	1/16W	R5809	1-218-958-11	RES-CHIP	2.7K	5%	1/16W
R5222	1-218-929-11	RES-CHIP	10	5%	1/16W	R5812	1-218-961-11	RES-CHIP	4.7K	5%	1/16W
R5445	1-216-295-91	SHORT CHIP	0			R5813	1-218-958-11	RES-CHIP	2.7K	5%	1/16W
R5606	1-218-940-11	RES-CHIP	82	5%	1/16W	R5814	1-218-961-11	RES-CHIP	4.7K	5%	1/16W
R5607	1-218-940-11	RES-CHIP	82	5%	1/16W	R5815	1-218-958-11	RES-CHIP	2.7K	5%	1/16W
R5608	1-218-965-11	RES-CHIP	10K	5%	1/16W	R5817	1-218-958-11	RES-CHIP	2.7K	5%	1/16W
R5609	1-218-965-11	RES-CHIP	10K	5%	1/16W	R5818	1-218-958-11	RES-CHIP	2.7K	5%	1/16W
R5610	1-218-953-11	RES-CHIP	1K	5%	1/16W	R5821	1-218-961-11	RES-CHIP	4.7K	5%	1/16W
R5612	1-218-965-11	RES-CHIP	10K	5%	1/16W	R5822	1-218-961-11	RES-CHIP	4.7K	5%	1/16W
R5613	1-218-953-11	RES-CHIP	1K	5%	1/16W	R5824	1-163-038-91	CERAMIC CHIP	0.1uF		25V
R5614	1-218-953-11	RES-CHIP	1K	5%	1/16W	R5825	1-234-370-21	RES, NETWORK	22 (1005X4)		
R5615	1-218-953-11	RES-CHIP	1K	5%	1/16W	R5826	1-234-370-21	RES, NETWORK	22 (1005X4)		
R5617	1-218-953-11	RES-CHIP	1K	5%	1/16W	R5827	1-234-370-21	RES, NETWORK	22 (1005X4)		
R5618	1-218-965-11	RES-CHIP	10K	5%	1/16W	R5828	1-234-370-21	RES, NETWORK	22 (1005X4)		
R5619	1-218-953-11	RES-CHIP	1K	5%	1/16W	R5829	1-218-938-11	RES-CHIP	56	5%	1/16W
R5622	1-218-940-11	RES-CHIP	82	5%	1/16W	R5831	1-218-990-81	SHORT CHIP	0		
R5623	1-218-940-11	RES-CHIP	82	5%	1/16W	R5833	1-218-933-11	RES-CHIP	22	5%	1/16W
R5624	1-218-940-11	RES-CHIP	82	5%	1/16W	R5834	1-218-933-11	RES-CHIP	22	5%	1/16W
R5626	1-218-933-11	RES-CHIP	22	5%	1/16W	R5836	1-218-965-11	RES-CHIP	10K	5%	1/16W
R5627	1-218-940-11	RES-CHIP	82	5%	1/16W	R5837	1-218-990-81	SHORT CHIP	0		
R5628	1-218-933-11	RES-CHIP	22	5%	1/16W	R5838	1-218-935-11	RES-CHIP	33	5%	1/16W
R5629	1-218-940-11	RES-CHIP	82	5%	1/16W	R5839	1-218-949-11	RES-CHIP	470	5%	1/16W
R5630	1-218-940-11	RES-CHIP	82	5%	1/16W	R5842	1-218-947-11	RES-CHIP	330	5%	1/16W
R5631	1-218-933-11	RES-CHIP	22	5%	1/16W	R5843	1-218-947-11	RES-CHIP	330	5%	1/16W
R5632	1-242-963-21	RES, NETWORK	33 (1005X4)			R5844	1-218-947-11	RES-CHIP	330	5%	1/16W
R5638	1-242-963-21	RES, NETWORK	33 (1005X4)			R5845	1-218-947-11	RES-CHIP	330	5%	1/16W
R5642	1-242-963-21	RES, NETWORK	33 (1005X4)			R5846	1-218-961-11	RES-CHIP	4.7K	5%	1/16W
R5646	1-242-963-21	RES, NETWORK	33 (1005X4)			R5848	1-218-961-11	RES-CHIP	4.7K	5%	1/16W
R5650	1-218-940-11	RES-CHIP	82	5%	1/16W	R5852	1-218-965-11	RES-CHIP	10K	5%	1/16W
R5651	1-218-873-11	METAL CHIP	12K	0.5%	1/10W	R5853	1-218-965-11	RES-CHIP	10K	5%	1/16W
R5652	1-218-941-81	RES-CHIP	100	5%	1/16W	R5854	1-218-965-11	RES-CHIP	10K	5%	1/16W
R5657	1-218-953-11	RES-CHIP	1K	5%	1/16W	R5855	1-234-369-21	RES, NETWORK	10 (1005X4)		
R5658	1-218-953-11	RES-CHIP	1K	5%	1/16W	R5856	1-218-965-11	RES-CHIP	10K	5%	1/16W
R5659	1-218-953-11	RES-CHIP	1K	5%	1/16W	R5857	1-218-965-11	RES-CHIP	10K	5%	1/16W
R5661	1-216-864-11	SHORT CHIP	0			R5859	1-218-965-11	RES-CHIP	10K	5%	1/16W
R5672	1-216-864-11	SHORT CHIP	0			R5861	1-218-965-11	RES-CHIP	10K	5%	1/16W
R5688	1-218-989-11	RES-CHIP	1M	5%	1/16W	R5862	1-218-961-11	RES-CHIP	4.7K	5%	1/16W
R5689	1-218-953-11	RES-CHIP	1K	5%	1/16W	R5863	1-218-951-11	RES-CHIP	680	5%	1/16W
R5690	1-218-990-81	SHORT CHIP	0			R5864	1-218-953-11	RES-CHIP	1K	5%	1/16W
R5692	1-218-990-81	SHORT CHIP	0			R5865	1-218-990-81	SHORT CHIP	0		
R5693	1-218-990-81	SHORT CHIP	0			R5867	1-218-950-11	RES-CHIP	560	5%	1/16W
R5701	1-218-949-11	RES-CHIP	470	5%	1/16W	R5868	1-218-957-11	RES-CHIP	2.2K	5%	1/16W
R5702	1-218-949-11	RES-CHIP	470	5%	1/16W	R5869	1-218-961-11	RES-CHIP	4.7K	5%	1/16W
R5703	1-218-951-11	RES-CHIP	680	5%	1/16W	R5870	1-218-970-11	RES-CHIP	27K	5%	1/16W
R5704	1-218-943-11	RES-CHIP	150	5%	1/16W	R5880	1-218-977-11	RES-CHIP	100K	5%	1/16W
R5705	1-216-864-11	SHORT CHIP	0			R6001	1-218-990-81	SHORT CHIP	0		
R5706	1-211-990-11	METAL CHIP	75	0.5%	1/10W	< VIBRATOR >					
R5707	1-218-977-11	RES-CHIP	100K	5%	1/16W	X5101	1-813-049-21	VIBRATOR, CRYSTAL (24.576MHz)			
R5803	1-164-360-11	CERAMIC CHIP	0.1uF		16V	X5201	1-795-904-21	OSCILLATOR, CRYSTAL (48MHz)			
R5804	1-218-973-11	RES-CHIP	47K	5%	1/16W	X5502	1-813-052-21	VIBRATOR, CRYSTAL (25MHz)			
R5805	1-218-961-11	RES-CHIP	4.7K	5%	1/16W	*****					

<u>Ref. No.</u>	<u>Part No.</u>	<u>Description</u>	<u>Remarks</u>	<u>Ref. No.</u>	<u>Part No.</u>	<u>Description</u>	<u>Remarks</u>
		ACCESSORIES					

	1-480-698-11	REMOTE COMMANDER (RMT-D251P)					
			(AEP, UK)				
	1-480-700-11	REMOTE COMMANDER (RMT-D2510) (AUS)					
△	1-575-131-82	CORD, POWER (AEP)					
	1-759-586-41	CONTROLLER, VIDEO (AV MOUSE) (AEP, UK)					
	1-696-593-11	CORD, CONNECTION (PAL)					
	1-828-145-11	CORD, CONNECTION (AV) (AUS)					
△	1-827-269-12	CORD, POWER (UK)					
△	1-555-074-52	CORD, POWER (AUS)					
	1-769-451-21	CORD, CONNECTION					
	3-295-080-11	MANUAL, INSTRUCTION (ENGLISH) (UK)					
	3-295-080-21	MANUAL, INSTRUCTION (FRENCH)					
			(AEP1, AEP3)				
	3-295-080-31	MANUAL, INSTRUCTION (GERMAN) (AEP1)					
	3-295-080-41	MANUAL, INSTRUCTION (ITALIAN) (AEP1)					
	3-295-080-51	MANUAL, INSTRUCTION (SPANISH) (AEP1)					
	3-295-080-61	MANUAL, INSTRUCTION (DUTCH)					
			(AEP1, AEP2)				
	3-295-080-71	MANUAL, INSTRUCTION (DANISH) (AEP2)					
	3-295-080-81	MANUAL, INSTRUCTION (SWEDISH) (AEP2)					
	3-295-080-91	MANUAL, INSTRUCTION (FINNISH) (AEP2)					
	3-879-466-11	MANUAL, INSTRUCTION (ENGLISH) (AUS)					

Note : The components identified by mark △ or dotted line with mark △ are critical for safety. Replace only with part number specified.

Revision History

Ver.	Date	History	Contents	S.M. Rev. issued
1.0	2008.06	Official Release	—	—
1.1	2008.11	Revised-1	Change of repair parts list (Page 8-2) Addition of Note (Page 8-2) Addition of IC101(Page 8-5)	Yes
1.2	2010.01	Revised-2	Addition of Note (Page 1-8)	Yes