

# AV RECEIVER/AV AMPLIFIER RX-V563/HTR-6150/ DSP-AX563 SERVICE MANUAL

## IMPORTANT NOTICE

This manual has been provided for the use of authorized YAMAHA Retailers and their service personnel. It has been assumed that basic service procedures inherent to the industry, and more specifically YAMAHA Products, are already known and understood by the users, and have therefore not been restated.

**WARNING:** Failure to follow appropriate service and safety procedures when servicing this product may result in personal injury, destruction of expensive components, and failure of the product to perform as specified. For these reasons, we advise all YAMAHA product owners that any service required should be performed by an authorized YAMAHA Retailer or the appointed service representative.

**IMPORTANT:** The presentation or sale of this manual to any individual or firm does not constitute authorization, certification or recognition of any applicable technical capabilities, or establish a principle-agent relationship of any form.

The data provided is believed to be accurate and applicable to the unit(s) indicated on the cover. The research, engineering, and service departments of YAMAHA are continually striving to improve YAMAHA products. Modifications are, therefore, inevitable and specifications are subject to change without notice or obligation to retrofit. Should any discrepancy appear to exist, please contact the distributor's Service Division.

**WARNING:** Static discharges can destroy expensive components. Discharge any static electricity your body may have accumulated by grounding yourself to the ground buss in the unit (heavy gauge black wires connect to this buss).

**IMPORTANT:** Turn the unit OFF during disassembly and part replacement. Recheck all work before you apply power to the unit.

RX-V563/HTR-6150/  
DSP-AX563

## CONTENTS

TO SERVICE PERSONNEL .....	2	DISPLAY DATA .....	45
FRONT PANELS .....	3-4	IC DATA .....	46-59
REAR PANELS .....	5-8	BLOCK DIAGRAMS .....	61-65
REMOTE CONTROL PANEL .....	9	PRINTED CIRCUIT BOARDS .....	66-79
SPECIFICATIONS .....	10-12	PIN CONNECTION DIAGRAMS .....	80-81
INTERNAL VIEW .....	13	SCHEMATIC DIAGRAMS .....	83-96
DISASSEMBLY PROCEDURES .....	14-16	REPLACEMENT PARTS LIST .....	97-109
UPDATING FIRMWARE .....	17-21	REMOTE CONTROL .....	110-112
SELF DIAGNOSIS FUNCTION (DIAG) .....	22-44	Advanced setup .....	113



このサービスマニュアルは、エコマーク認定の再生紙を使用しています。  
This Service Manual uses recycled paper.

101086

© 2008 YAMAHA CORPORATION All rights reserved.  
This manual is copyrighted by YAMAHA and may not be copied or  
redistributed either in print or electronically without permission.



**YAMAHA**

YAMAHA CORPORATION  
P.O.Box 1, Hamamatsu, Japan

'08.03

## ■ TO SERVICE PERSONNEL

### 1. Critical Components Information

Components having special characteristics are marked  and must be replaced with parts having specifications equal to those originally installed.

### 2. Leakage Current Measurement (For 120V Models Only)

When service has been completed, it is imperative to verify that all exposed conductive surfaces are properly insulated from supply circuits.

- Meter impedance should be equivalent to 1500 ohms shunted by 0.15µF.

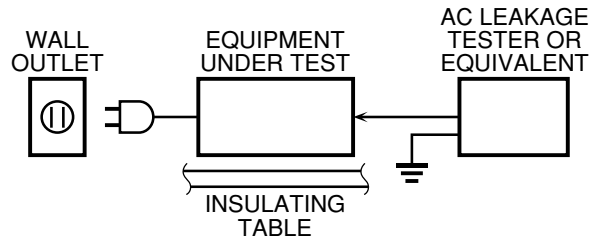

- Leakage current must not exceed 0.5mA.
- Be sure to test for leakage with the AC plug in both polarities.



#### For U model "CAUTION"

"F3401, F3402: FOR CONTINUED PROTECTION AGAINST RISK OF FIRE, REPLACE ONLY WITH SAME TYPE 6A, 125V FUSE."

#### For C model CAUTION

F3401, F3402: REPLACE WITH SAME TYPE 6A, 125V FUSE.

#### ATTENTION

F3401, F3402: UTILISER UN FUSIBLE DE RECHANGE DE MÊME TYPE DE 6A, 125V.

## WARNING: CHEMICAL CONTENT NOTICE!

This product contains chemicals known to the State of California to cause cancer, or birth defects or other reproductive harm.

DO NOT PLACE SOLDER, ELECTRICAL/ELECTRONIC OR PLASTIC COMPONENTS IN YOUR MOUTH FOR ANY REASON WHAT SO EVER!

Avoid prolonged, unprotected contact between solder and your skin! When soldering, do not inhale solder fumes or expose eyes to solder/flux vapor!

If you come in contact with solder or components located inside the enclosure of this product, wash your hands before handling food.

## About lead free solder

All of the P.C.B.s installed in this unit and solder joints are soldered using the lead free solder.

Among some types of lead free solder currently available, it is recommended to use one of the following types for the repair work.

- Sn + Ag + Cu (tin + silver + copper)
- Sn + Cu (tin + copper)
- Sn + Zn + Bi (tin + zinc + bismuth)

#### Caution:

As the melting point temperature of the lead free solder is about 30°C to 40°C (50°F to 70°F) higher than that of the lead solder, be sure to use a soldering iron suitable to each solder.

# FRONT PANELS

## RX-V563 (U, C models)

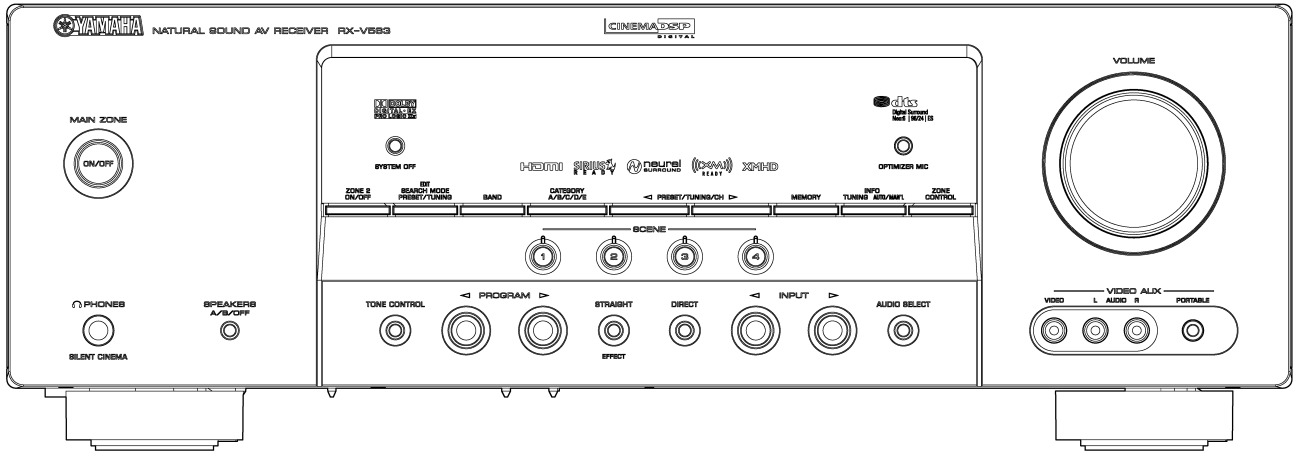

## RX-V563 (R, T, K, A, G, E, F, L models)

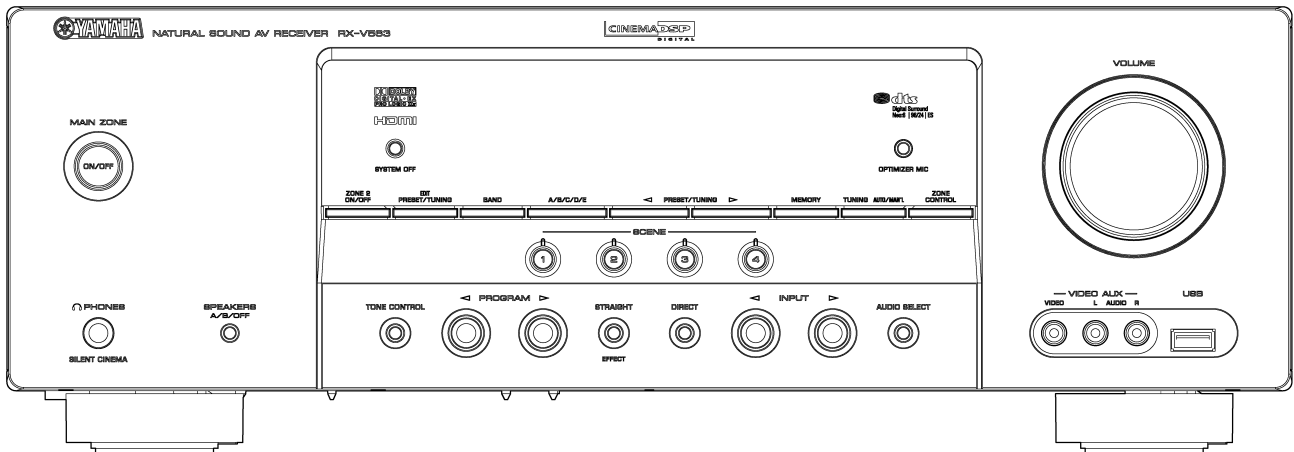

## HTR-6150 (U, C models)

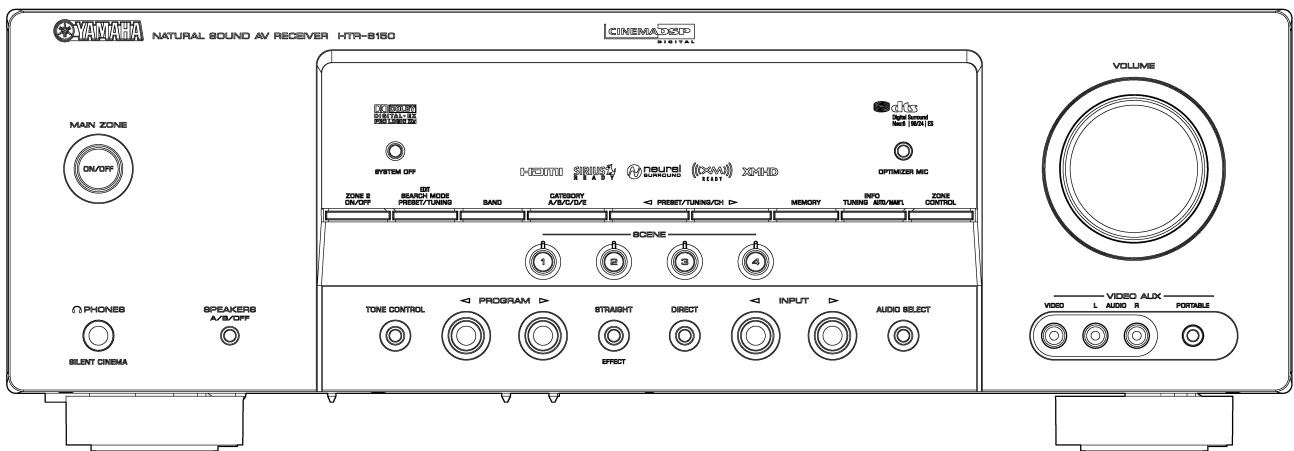

RX-V563/HTR-6150/  
DSP-AX563

HTR-6150 (F model)

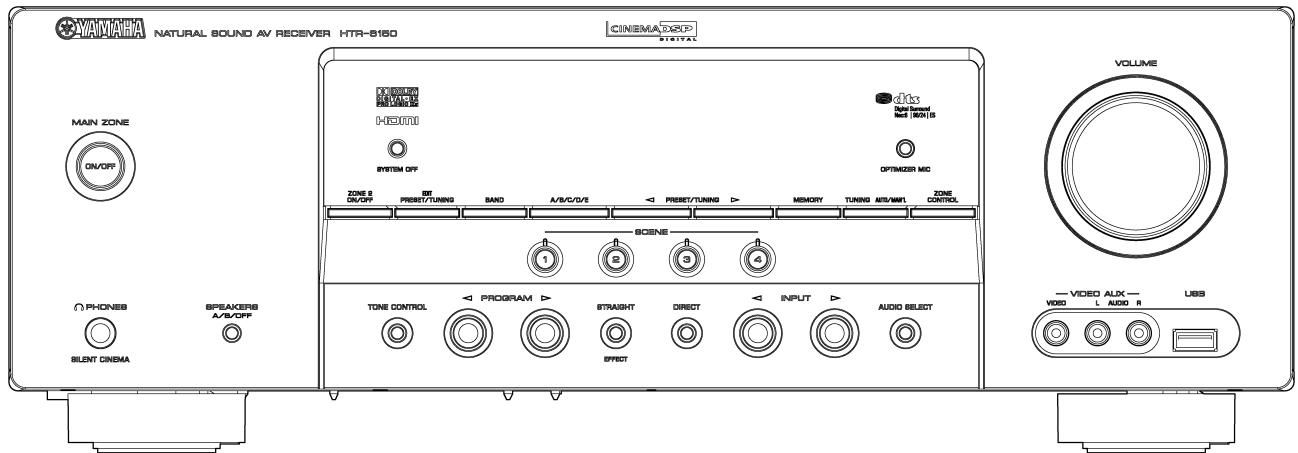

DSP-AX563 (B model)

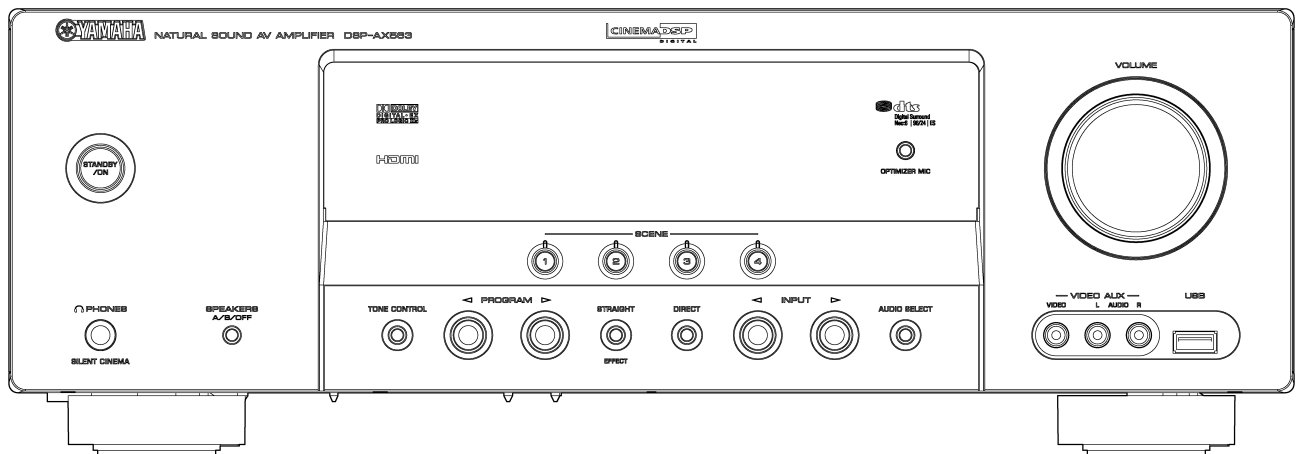

RX-V563/HTR-6150/  
DSP-AX563



RX-V563 (K model)

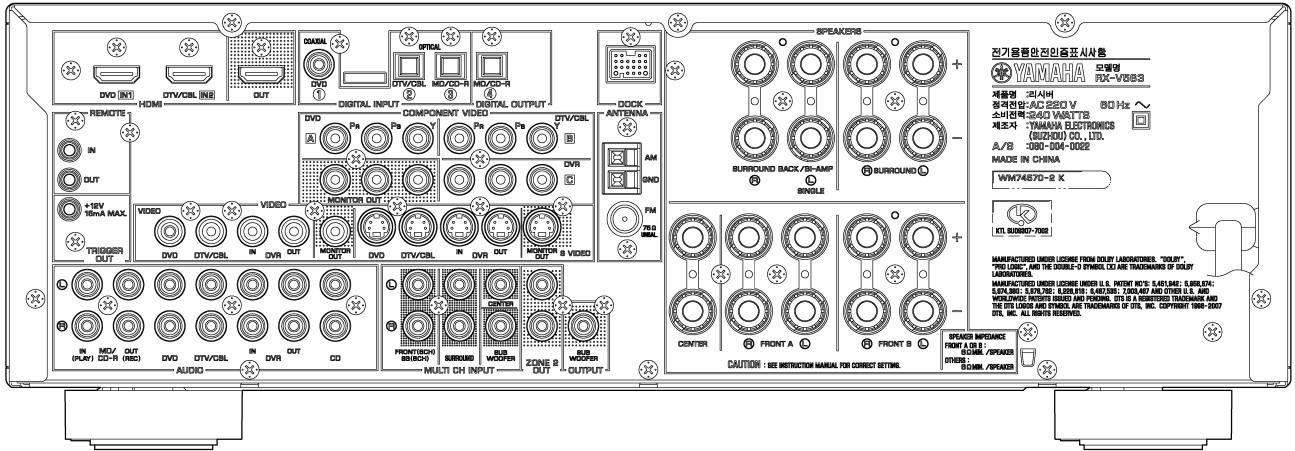

RX-V563 (A model)

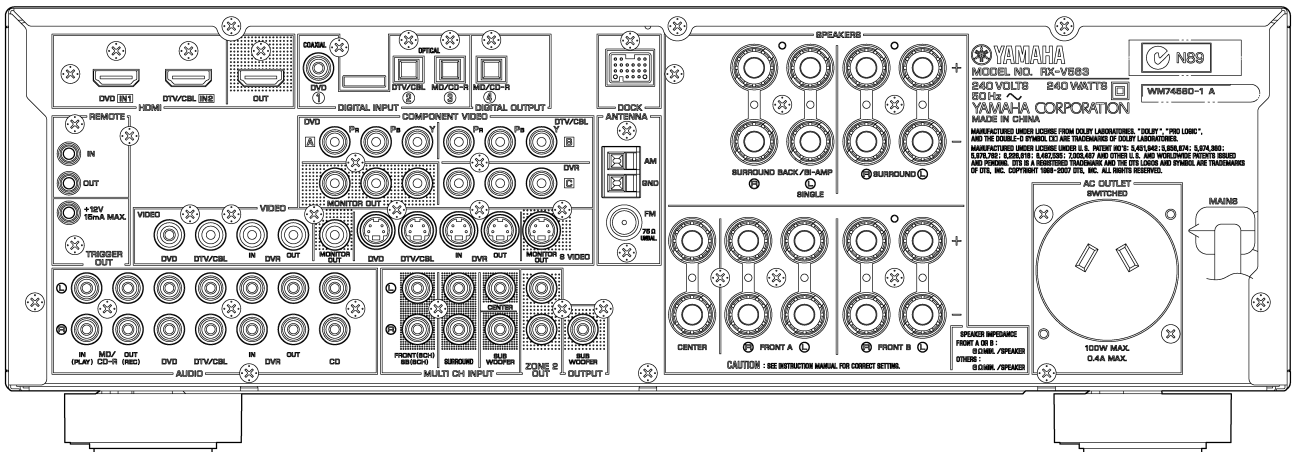

RX-V563 (G, E, F models)

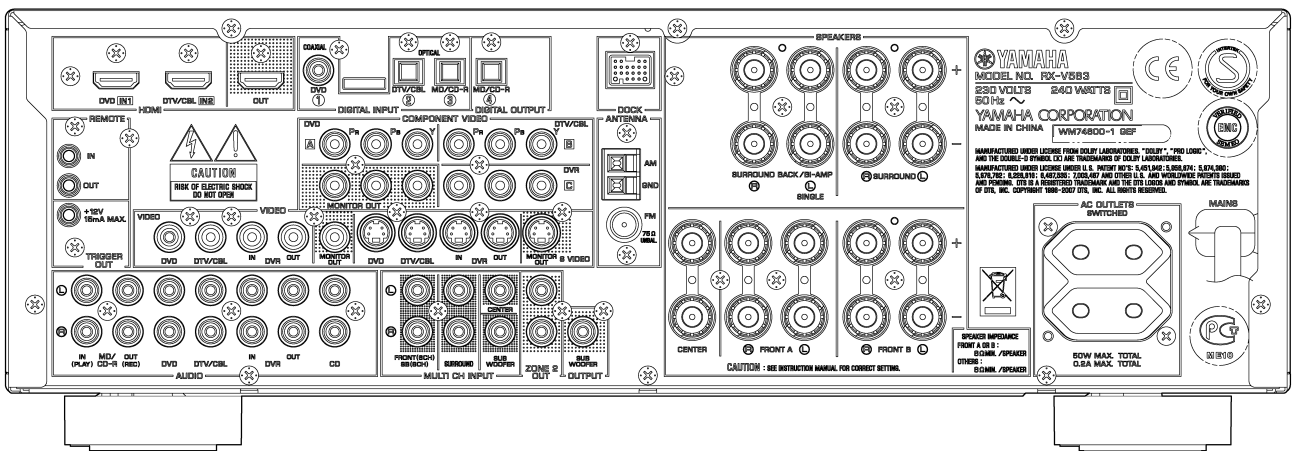

RX-V563 (L model)

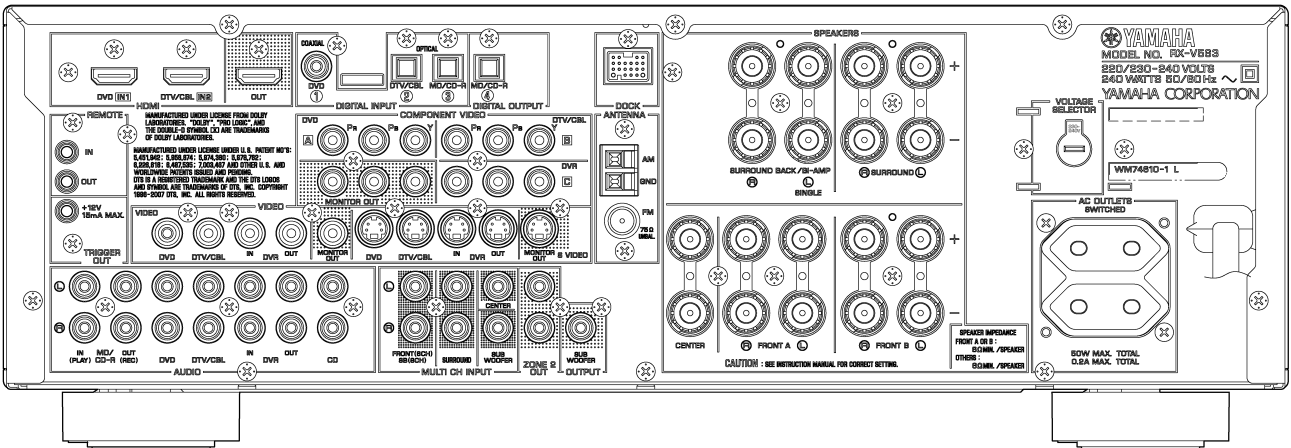

HTR-6150 (U, C models)

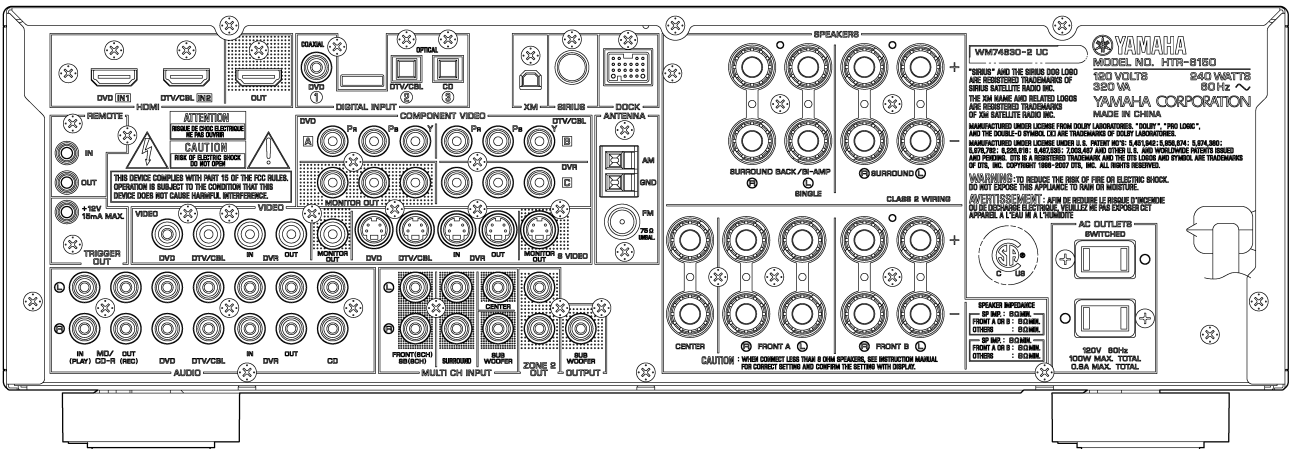

HTR-6150 (F model)

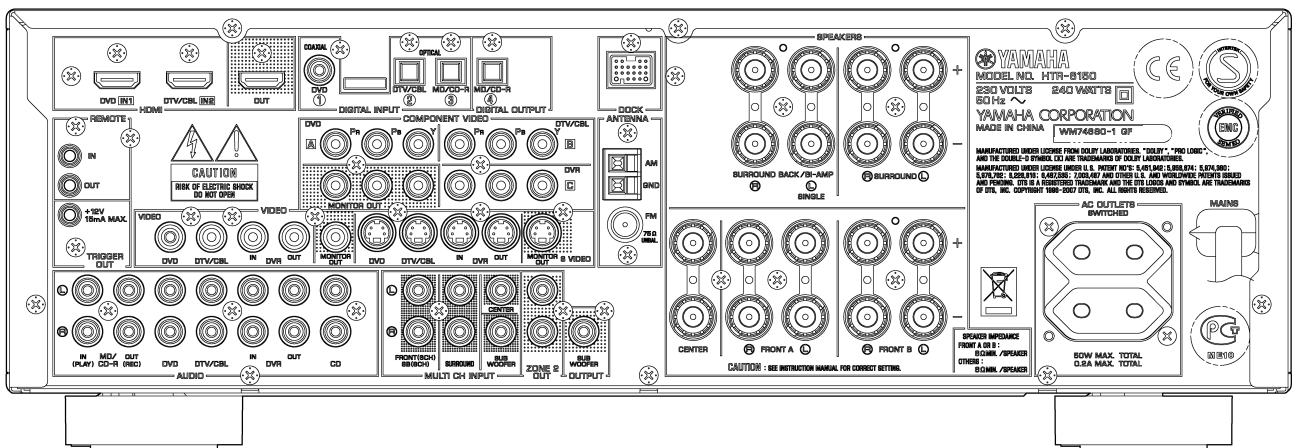

RX-V563/HTR-6150/  
DSP-AX563

DSP-AX563 (B model)

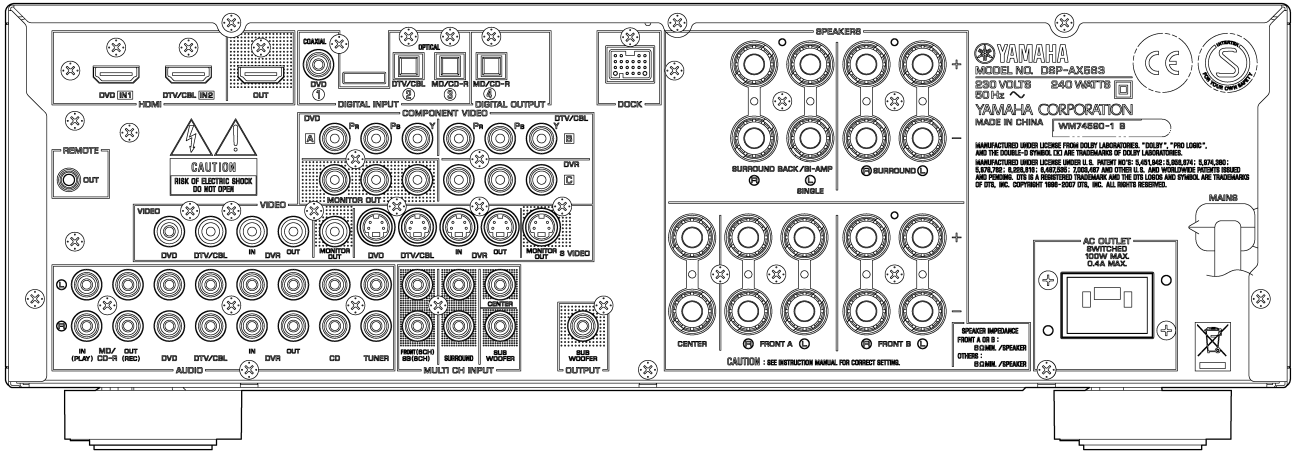



## ■ REMOTE CONTROL PANEL

- RAV280**  
 RX-V563 (U, C models)  
 HTR-6150 (U, C models)
- RAV282**  
 RX-V563 (R, T, K, A, G, E, F, L models)  
 HTR-6150 (F model)  
 DSP-AX563 (B model)

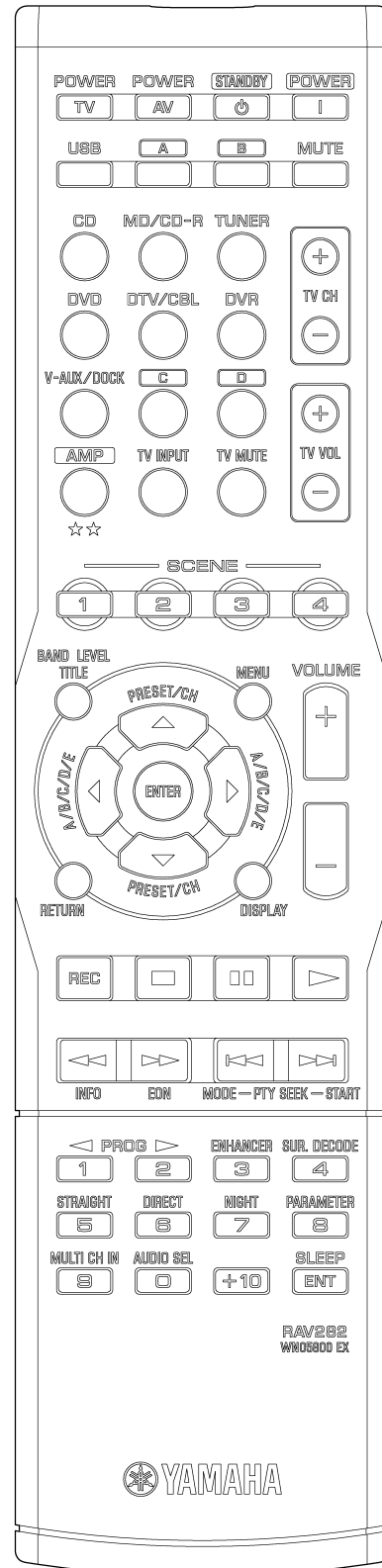
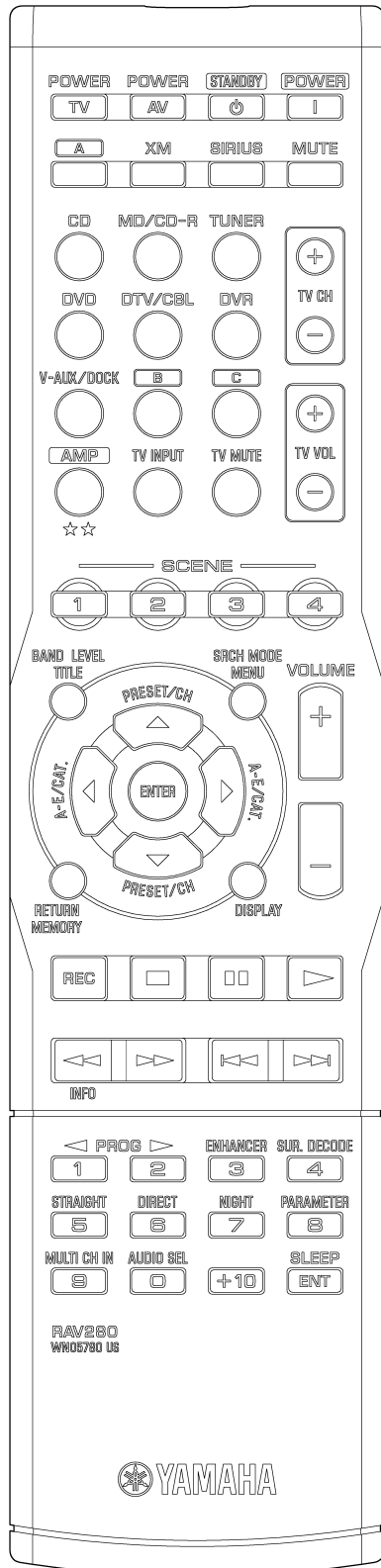

RX-V563/HTR-6150/  
 DSP-AX563

## ■ SPECIFICATIONS

### ■ Audio Section

#### Minimum RMS Output Power (Power Amp. Section)

(1 kHz, 0.9 % THD)  
 FRONT L/R, CENTER, SURROUND L/R, SURROUND BACK L/R  
 U, C models (8 ohms) ..... 90 W/ch  
 R, T, K, A, B, G, E, F, L models (6 ohms) ..... 90 W/ch

**Maximum Power (JEITA)** (1 kHz, 0.9 % THD, 6 ohms)  
 FRONT L/R, CENTER, SURROUND L/R, SURROUND BACK L/R  
 R, T, K, L models ..... 115 W/ch

**Dynamic Power Per Channel (IHF)** (FRONT L/R drive)  
 U, C models  
 (8/6/4/2 ohms) ..... 90/110/130/150 W  
 R, T, K, A, B, G, E, F, L models  
 (6/4/2 ohms) ..... 100/110/125 W

**Dynamic Headroom**  
 U, C models (8 ohms) ..... 0.18 dB

**Input Sensitivity/Input Impedance** (1 kHz, 100 W / 8 ohms)  
 CD, etc. .... 200 mV / 47 k-ohms  
 MULTI CH INPUT  
 FRONT L/R, CENTER, SURROUND L/R, SUBWOOFER  
 ..... 200 mV / 47 k-ohms

**Maximum Input Signal** (1 kHz, 0.5 % THD, Effect on)  
 CD, etc. .... 2.0 V or more

**Output Level/Output Impedance**  
 REC OUT ..... 200 mV / 1.2 k-ohms  
 SUBWOOFER (2ch STEREO and FRONT SP: Small)  
 ..... 4 V / 1.2 k-ohms

**Headphone Jack Rated Output/Impedance**  
 CD, etc. (1 kHz, 200 mV, 8 ohms) ..... 400 mV / 470 ohms

**Frequency Response** (10 Hz to 100 kHz)  
 CD, etc. to FRONT L/R ..... 0 / -3 dB

**Total Harmonic Distortion** (1 kHz, 50 W)  
 Direct to FRONT L/R SP OUT  
 U, C models (8 ohms) ..... 0.06 % or less  
 R, T, K, A, B, G, E, F, L models (6 ohms) .. 0.06 % or less

**Signal to Noise Ratio (IHF-A Network)**  
 Direct STEREO to Input shorted SP OUT  
 200 mV ..... 98 dB or more  
 250 mV ..... 100 dB or more

**Residual Noise (IHF-A Network)**  
 FRONT L/R SP OUT ..... 150 µV or less

**Channel Separation**  
 CD, etc. (Input 5.1 k-ohms shorted, 1 kHz / 10 kHz)  
 ..... 60 dB or more / 45 dB or more

**Tone Control Characteristics**  
 BASS  
 Boost/Cut ..... ±10 dB (100 Hz)  
 TREBLE  
 Boost/Cut ..... ±10 dB (20 kHz)

**Filter Characteristics**  
 FRONT, CENTER, SURROUND, SURROUND BACK small (H.P.F.)  
 ..... fc=40/60/80/90/100/110/120/160/200 Hz, 12 dB/oct.  
 SUBWOOFER (L.P.F.)  
 ..... fc=40/60/80/90/100/110/120/160/200 Hz, 24 dB/oct.

### ■ Video Section

**Video Signal Type**  
**Gray back**  
 U, C, R, K models ..... NTSC  
 T, A, B, G, E, F, L models ..... PAL  
**Video conversion**  
 ..... NTSC/PAL

**Composite Video Signal Level**  
 ..... 1 Vp-p / 75 ohms

**S-Video Signal Level**  
 Y ..... 1 Vp-p / 75 ohms  
 C ..... 0.286 Vp-p / 75 ohms

**Component Signal Level**  
 Y ..... 1 Vp-p / 75 ohms  
 Pb/Pr ..... 0.7 Vp-p / 75 ohms

**Video Maximum Input Level**  
 ..... 1.5 Vp-p or more

**Signal to Noise Ratio**  
 ..... 50 dB or more

**Monitor Out Frequency Response**  
 Component video signal ..... 5 Hz to 60 MHz, -3 dB  
**HDMI** ..... Ver. 1.2a

### ■ FM Section [U, C, R, T, K, A, G, E, F, L models]

**Tuning Range**  
 U, C models ..... 87.5 to 107.9 MHz  
 R, L models ..... 87.5 to 108.0 / 87.50 to 108.00 MHz  
 T, K, A, G, E, F models ..... 87.50 to 108.00 MHz

**50dB Quieting Sensitivity (IHF)** (1 kHz, 100 % Mod.)  
 Mono ..... 2.8 µV (20.2 dBf)

**Signal to Noise Ratio (IHF)**  
 Mono / Stereo ..... 73 dB / 70 dB

**Harmonic Distortion** (1 kHz)  
 Mono / Stereo ..... 0.5 % / 0.5 %

**Antenna Input** ..... 75 ohms unbalanced

### ■ AM Section [U, C, R, T, K, A, G, E, F, L models]

**Tuning Range**  
 U, C models ..... 530 to 1,710 kHz  
 R, L models ..... 530 to 1,710 / 531 to 1,611 kHz  
 T, K, A, G, E, F models ..... 531 to 1,611 kHz

**Antenna Input** ..... Loop antenna

### ■ General

**Power Supply**  
 U, C models ..... AC 120 V, 60 Hz  
 R model ..... AC 110, 120/220, 230-240 V, 50/60 Hz  
 T model ..... AC 220 V, 50 Hz  
 K model ..... AC 220 V, 60 Hz  
 A model ..... AC 240 V, 50 Hz  
 B, G, E, F models ..... AC 230 V, 50 Hz  
 L model ..... AC 220, 230-240 V, 50/60 Hz

**Power Consumption**  
 U, C models ..... 240 W / 320 VA  
 R model ..... 260 W  
 T, K, A, B, G, E, F, L models ..... 240 W

RX-V563/HTR-6150/DSP-AX563

**Standby Power Consumption (reference data)**

U, C, T, K, A, B, G, E, F models ..... 0.8 W

**Maximum Power Consumption (5ch drive, 10 % THD)**

R, L models ..... 490 W

**AC Outlets**

2 switched outlets

U, C models ..... 100 W max. total

R, T, G, E, F, L models ..... 50 W max. total

1 switched outlet

A, B models ..... 100 W max.

**Dimensions (W x H x D)**

..... 435 x 151 x 351.6 mm (17-1/8" x 5-15/16" x 13-13/16")

**Weight** ..... 9.0 kg (19 lbs. 13 oz.)

**Finish**

**[RX-V563]**

Gold color ..... R, T models

Black color ..... U, C, R, A, G, E, F models

Titanium color ..... K, G, E, F, L models

Silver color ..... A, L models

**[HTR-6150]**

Black color ..... U, C, F models

Silver color ..... F model

**[DSP-AX563]**

Black color ..... B model

Titanium color ..... B model

**Accessories** ..... Remote control x 1

Batteries (R03, AAA, UM-4) x 2

Indoor FM antenna x 1 (U, C, R, T, K, A, G, E, F, L models)

AM loop antenna x 1 (U, C, R, T, K, A, G, E, F, L models)

Optimizer microphone x 1

\* Specifications are subject to change without notice due to product improvements.

※ 参考仕様および外観は予告なく変更されることがあります。

- U ..... U.S.A. model
- C ..... Canadian model
- R ..... General model
- T ..... Chinese model
- K ..... Korean model
- A ..... Australian model
- B ..... British model
- G ..... European model
- E ..... South European model
- F ..... Russian model
- L ..... Singapore model



Manufactured under license from Dolby Laboratories. "Dolby", "Pro Logic", and the double-D symbol are trademarks of Dolby Laboratories.

SILENT™ CINEMA

"SILENT CINEMA" is a trademark of YAMAHA CORPORATION.

iPod™

"iPod" is a trademark of Apple, Inc., registered in the U.S. and other countries.

**Bluetooth™**

Bluetooth is a registered trademark of the Bluetooth SIG and is used by Yamaha in accordance with a license agreement.



"HDMI", the "HDMI" logo and "High-Definition Multimedia Interface" are trademarks or registered trademarks of HDMI Licensing LLC.



DTS-ES | NEO:6 | 96/24. Product "DTS" and "DTS-ES | NEO:6" are registered trademarks of DTS, Inc. "96/24" is a trademark of DTS, Inc.



The XM name and related logos are registered trademarks of XM Satellite Radio Inc.



Neural Surround™ name and related logos are trademarks owned by Neural Audio Corporation.



©2006 SIRIUS Satellite Radio Inc. "SIRIUS", "Sirius Connect", the SIRIUS dog logo, channel names and logos are trademarks of SIRIUS Satellite Radio Inc.

**• DIMENSIONS**

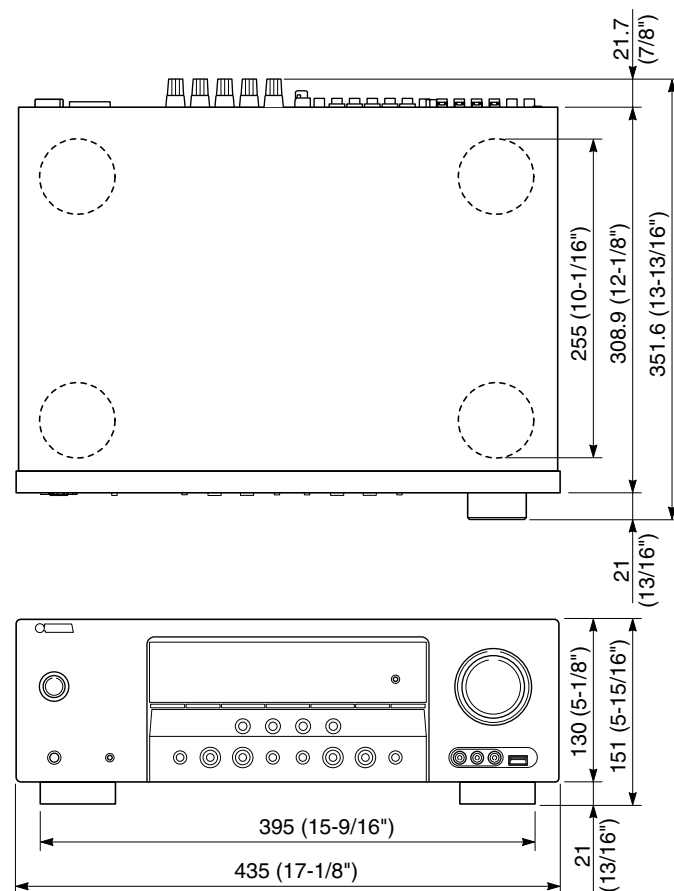

Unit: mm (inch)

**• SCENE TEMPLATE**

SCENE name	Contents		Source	Program		NIGHT	Select (Default)	
				Mode	Sub-mode		U, C models	R, T, K, A, B, G, E, F, L models
DVD Viewing	DVD	Movie	DVD	STRAIGHT	-	SYSTEM	O (SCENE 1)	O
DVD Movie Viewing			DVD	MOVIE	Movie Dramatic	SYSTEM	O	O (SCENE 1)
DVD Live Viewing		Music Live	DVD	MUSIC	Pop/Rock	SYSTEM	O	O
DVR Viewing	DVR		DVR	MOVIE	Movie Dramatic	SYSTEM	O	O
Disc Hi-fi Listening	DVD-Audio / SA-CD / CD	Music Disc	DVD	DIRECT STEREO	-	SYSTEM	O	O
Music Disc Listening			DVD	STEREO	2ch Stereo	SYSTEM	O	O (SCENE 2)
Disc Listening			DVD	STEREO	7ch Stereo	SYSTEM	O (SCENE 2)	O
CD Hi-fi Listening	CD	Music Disc	CD	DIRECT STEREO	-	SYSTEM	O	O
CD Listening			CD	STEREO	7ch Stereo	SYSTEM	O	O
CD Music Listening			CD	STEREO	2ch Stereo	SYSTEM	O	O
Radio Listening	TUNER/RADIO	FM/AM	FM/AM (TUNER)	MUSIC ENHANCER	7ch Enhancer	SYSTEM	O (SCENE 4)	O (SCENE 4)
XM Listening		XM	XM	MUSIC ENHANCER	7ch Enhancer	SYSTEM	O	-
SIRIUS Listening		SIRIUS	SIRIUS	MUSIC ENHANCER	7ch Enhancer	SYSTEM	O	-
Dock Listening	DAP	iPod Bluetooth	DOCK (V-AUX)	MUSIC ENHANCER	7ch Enhancer	SYSTEM	O	O
USB Audio Listening		USB	USB	MUSIC ENHANCER	7ch Enhancer	SYSTEM	-	O
TV Viewing	TV		DTV/CBL	STRAIGHT	-	SYSTEM	O (SCENE 3)	O (SCENE 3)
TV Sports Viewing			DTV/CBL	ENTERTAINMENT	TV Sports	SYSTEM	O	O
Game Playing	GAME		V-AUX	ENTERTAINMENT	Game	SYSTEM	O	O

**• SOUND/SURROUND SELECT MENU**

Sound Field Parameters

		DSP LEVEL MIN, [MID], MAX	MUSIC ENHANCER LOW, [HIGH]
STEREO	2ch Stereo		
	7ch Stereo		
MUSIC	Pop/Rock	O	
	Hall	O	
	Jazz	O	
ENTERTAIN	Game	O	
	TV Sports	O	
MOVIE	Movie Spacious	O	
	Movie Dramatic	O	
MUSIC ENHANCER	Music Enh. 2ch		O
	Music Enh. 7ch		O

Surround Decoders

		PANORAMA ON, [OFF]	DIMENSION -3, [STD], +3	CENTER WIDTH 0, 1, 2, [3], 4, 5, 6, 7	CENTER IMAGE 0.0, [0.3], 1.0
DECODING FORMAT	Dolby Digital				
	DTS				
POST DECODING FORMAT	Dolby Pro Logic				
	Dolby Pro Logic IIx, II Music	O	O	O	
	Dolby Pro Logic IIx, II Movie				
	Dolby Pro Logic IIx, II Game				
	Neo:6 Cinema				
	Neo:6 Music				O
	Neural Surround (U, C models)				

• SET MENU TABLE

CATEGORY	MAIN MENU	SUB MENU	SELECT MENU	VALUE [INITIAL]			
AUTO SETUP	Use this feature to automatically adjust speaker and system parameters.	FRONT B FRONT	FRONT	[FRONT] / ZONE B			
			LARGE	SMALL / [LARGE]			
MANUAL SETUP	1 SOUND MENU	A) SPEAKER SET	CENTER	NONE / [SMALL] / LARGE			
			SUR. LR	NONE / [SMALL] / LARGE			
			SUR. BLR	NONE / SMLx1 / [SMLx2] / LRGx1 / LRGx2			
			BASS OUT	SWFR / FRONT / [BOTH]			
			CROSSOVER	80 Hz			
			SWFR PHASE	NRM			
			FL	.....    .....*			
			FR	.....    .....*			
			C	.....    .....*			
			SWFR	.....    .....*			
			SUR. L	.....    .....*			
			SUR. R	.....    .....*			
			SBL	.....    .....*			
			SBR	.....    .....*			
			B) SP LEVEL			UNIT	feet / meters
FRONT L	10.0 ft						
FRONT R	10.0 ft						
CENTER	8.5 ft						
SWFR	10.0 ft						
SUR. L	8.0 ft						
SUR. R	8.0 ft						
SB L	8.0 ft						
SB R	8.0 ft						
FRONT L	3.00 m						
FRONT R	3.00 m						
CENTER	2.60 m						
SWFR	3.00 m						
SUR. L	2.40 m						
SUR. R	2.40 m						
SB L	2.40 m						
SB R	2.40 m						
C) SP DISTANCE			UNIT: feet				
			FRONT L	10.0 ft			
			FRONT R	10.0 ft			
			CENTER	8.5 ft			
			SWFR	10.0 ft			
			SUR. L	8.0 ft			
			SUR. R	8.0 ft			
			SB L	8.0 ft			
			SB R	8.0 ft			
			FRONT L	3.00 m			
			FRONT R	3.00 m			
			CENTER	2.60 m			
			SWFR	3.00 m			
			SUR. L	2.40 m			
			SUR. R	2.40 m			
SB L	2.40 m						
SB R	2.40 m						
D) CENTER GEQ			TEST TONE	[OFF] / ON			
			100 Hz	--    -- 0 dB			
			300 Hz	--    -- 0 dB			
			1 kHz	--    -- 0 dB			
			3 kHz	--    -- 0 dB			
			10 kHz	--    -- 0 dB			
			SP LFE	0 dB			
			HP LFE	0 dB			
			SP D. R	MAX			
			HP D. R	MAX			
			MUTE TYP	FULL			
			A. DELAY	0 ms			
			MAX VOL.	+16 dB			
			INI. VOL.	OFF			
			S. AUDIO				
>AUTO	LAST						
EXTD	AUTO						
E) LFE LEVEL			IN (1) [COAXIAL]	DVD			
			IN (2) [OPTICAL]	DTV/CBL			
			IN (3) [OPTICAL]	CD			
			HDMI1	DVD			
			HDMI2	DTV/CBL			
			F) D. RANGE			MIN / STD / [MAX]	
						[FULL] / -20 dB	
						0 to 160 ms, [0 ms], 1 ms step	
						+16 dB / +10 to -30 dB, [+16 dB], 5 dB step	
						OFF / MUTE / -80 to +16 dB, [OFF], 1 dB step	
						[RX-V563 / HTR-6150 / DSP-AX563] / OTHER	
						[AUTO] / LAST	
						[AUTO] / PLoixMovie / PLoixMusic / EX/ES / OFF	
						CD / MD/CD-R / [DVD] / DTV/CBL / V-AUX / DVR / TUNER (B model)	
						CD / MD/CD-R / DVD / [DTV/CBL] / V-AUX / DVR / TUNER (B model)	
[CD] / MD/CD-R / DVD / DTV/CBL / V-AUX / DVR / TUNER (B model)							
[DVD] / DTV/CBL / V-AUX / DVR							
DVD / [DTV/CBL] / V-AUX / DVR							
CD / MD/CD-R / DVD / DTV/CBL / V-AUX / DVR							
G) AUDIO SET						Input is possible to 8 characters	
			Input possible Character type: Capital/ A to Z, Small/ a to z, Figure/ 0 to 9, Space, Marks/ # * + , - . / : < > ?				
			CD / MD/CD-R / TUNER / DVD / DTV/CBL / V-AUX / DVR / DOCK / USB (X, X models) / MULTI CH / XM (U, C models) / SIRIUS (U, C models)				
			-6.0 to +6.0 dB, [0.0 dB], 1.0 dB step				
			[AUTO] / LAST				
			[AUTO] / DTS				
			DVD / DTV/CBL / V-AUX / DVR / [LAST]				
			[6CH] / 8CH				
			[DVD] / DTV/CBL / DVR / V-AUX				
			* Setting is possible only when 8ch is selected using "INPUT CH".				
			-4 to 0, [0], 1 step				
			[ON] / OFF				
			[CONT] / ONCE				
			-5 (upward) to +5 (downward), [0], 1step				
			ON / 10s / [30s]				
ON / 10s / [30s]							
[OFF] / ON							
[AUTO] / LAST							
[NO] / YES							
NONE / 0 to 100 %							
[OFF] / SINGLE / ALL							
[OFF] / ON							
Analog / --- / --- / --- / --- / --- / --- / --- / ---							
3/2/0.1 (front/surround/LFE)							
DTS, Dolby Digital, or PCM							
(HDMI -> DVI)							
(1080p -> 1080p)							
DEVICE OVER / HDCP ERROR / OUT OF RES.							
2 INPUT MENU			CD / DTV/CBL / V-AUX				
			BGV	LAST			
			INPUT CH	6CH			
			FRONT	DVD			
			DIMMER	0			
			VIDEO CONV.	ON			
			FL SCROLL	CONT			
			OSD SHIFT	0			
			OSD-SOURCE	30s			
			OSD-AMP	30s			
			MEMORY GUARD	OFF			
			>AUTO	LAST			
			XM ANT.				
			PARENTAL LOCK				
			REPEAT	OFF			
SHUFFLE	OFF						
3 OPTION MENU	(U, C models) (R, T, K, A, B, G, E, F, L models)		FORMAT (Signal format)				
			SAMPLING				
			CHANNEL				
			BITRATE				
			FLAG				
			HDMI SIGNAL				
			HDMI RES.				
			HDMI ERROR (HDMI MESSAGE)				
			SIGNAL INFO				
			AUDIO				
			VIDEO				

## INTERNAL VIEW

• Top view

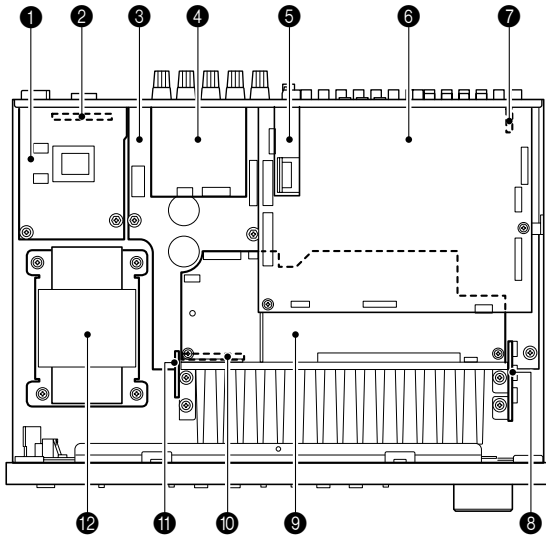

- ① VIDEO (3) P.C.B.
- ② VIDEO (5) P.C.B. (R, L models)
- ③ MAIN (1) P.C.B.
- ④ VIDEO (4) P.C.B.
- ⑤ Tuner
- ⑥ DSP P.C.B.
- ⑦ VIDEO (6) P.C.B.
- ⑧ OPERATION (8) P.C.B.
- ⑨ OPERATION (2) P.C.B.
- ⑩ MAIN (2) P.C.B.
- ⑪ OPERATION (9) P.C.B.
- ⑫ Power Transformer
- ⑬ OPERATION (3) P.C.B.
- ⑭ OPERATION (7) P.C.B.
- ⑮ OPERATION (1) P.C.B.
- ⑯ OPERATION (5) P.C.B. (U, C models)  
OPERATION (4) P.C.B. (R, T, K, A, B, G, E, F, L models)
- ⑰ OPERATION (6) P.C.B. (R, T, K, A, B, G, E, F, L models)
- ⑱ VIDEO (2) P.C.B.
- ⑲ VIDEO (1) P.C.B.

• Front view

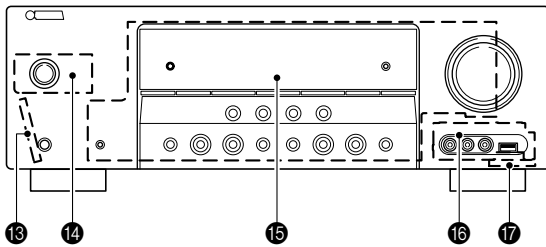

• Rear view

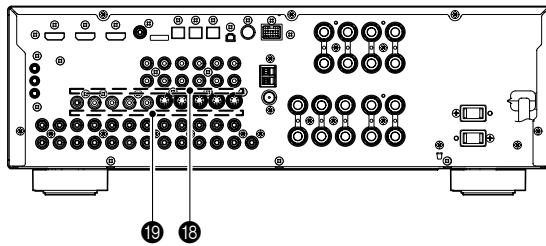

## DISASSEMBLY PROCEDURES

(Remove parts in the order as numbered.)  
 Disconnect the power cable from the AC outlet.

### 1. Removal of Top Cover

- a. Remove 5 screws (①), 4 screws (②) and 1 screw (③). (Fig. 1)
- b. Slide the top cover rearward to remove it. (Fig. 1)

### 2. Removal of Front Panel Unit

- a. Remove 6 screws (④). (Fig. 1)
- b. Remove CB71 (R, T, K, A, B, G, E, F, L models), CB83, CB366, CB601, CB602, CB608 and CB703. (Fig. 1)
- c. Release hook and then remove the front panel unit. (Fig. 1)

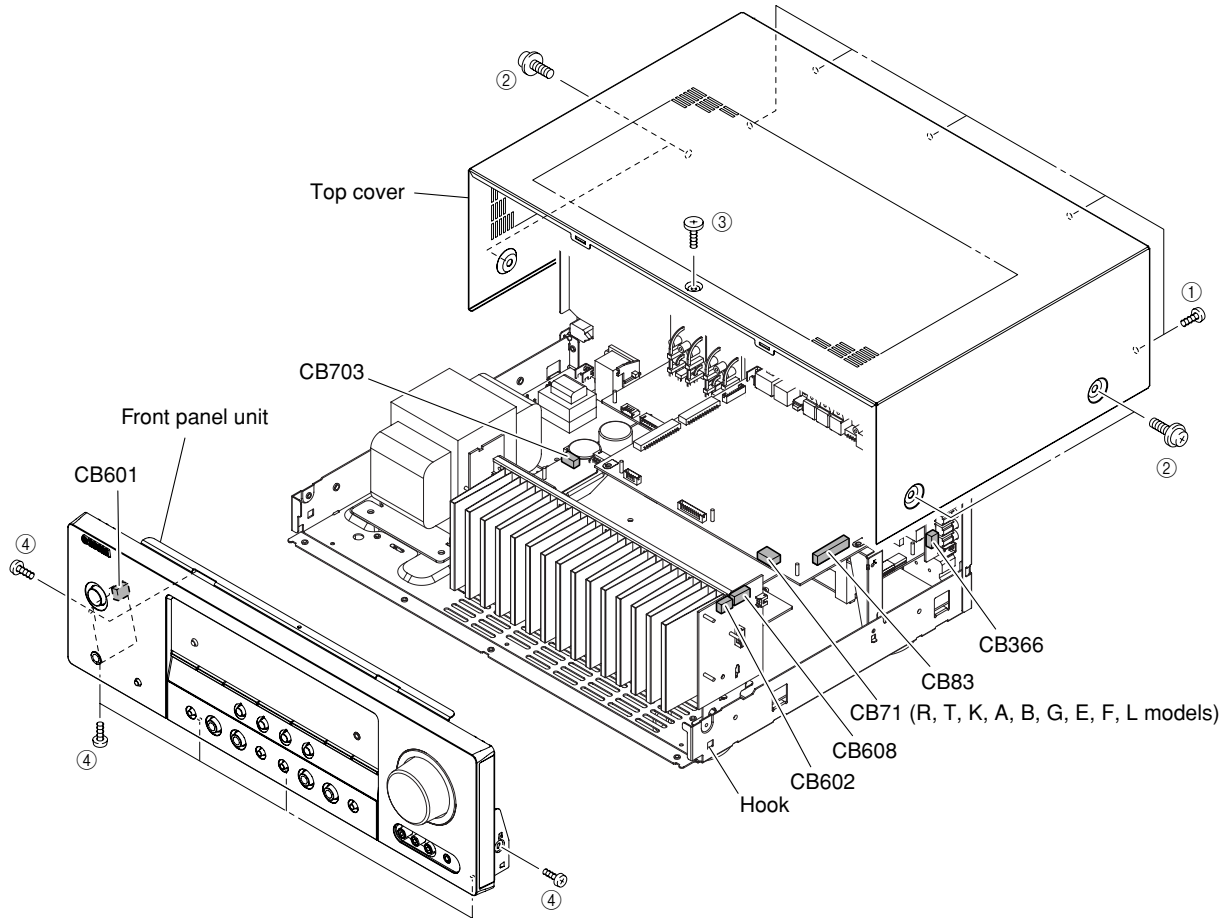

Fig. 1

RX-V563/HTR-6150/DSP-AX563

### 3. Removal of DSP P.C.B.

**Note:** U, C, F models

After replacement of DSP P.C.B. or writing of the firmware, make sure to activate the self-diagnostic function and change the "M6 Model ID" setting to the same model name as this unit (RX-V563 or HTR-6150).

- Remove 2 screws (5). (Fig. 2)
- Remove 11 screws (U, C models) / 10 screws (R, T, K, A, B, G, E, F, L models) (6). (Fig. 3)
- Remove CB21, CB22, CB31, CB32, CB81, CB82 and CB84. (Fig. 2)
- Remove DSP P.C.B. (Fig. 2)

### 4. Removal of VIDEO (1), (2) and (6) P.C.B.s

- Remove 2 screws (7). (Fig. 3)
- Remove VIDEO (6) P.C.B. (Fig. 2)
- Remove 9 screws (8). (Fig. 3)
- Remove CB301 and CB609. (Fig. 2)
- Remove VIDEO (1) and (2) P.C.B.s. (Fig. 2)

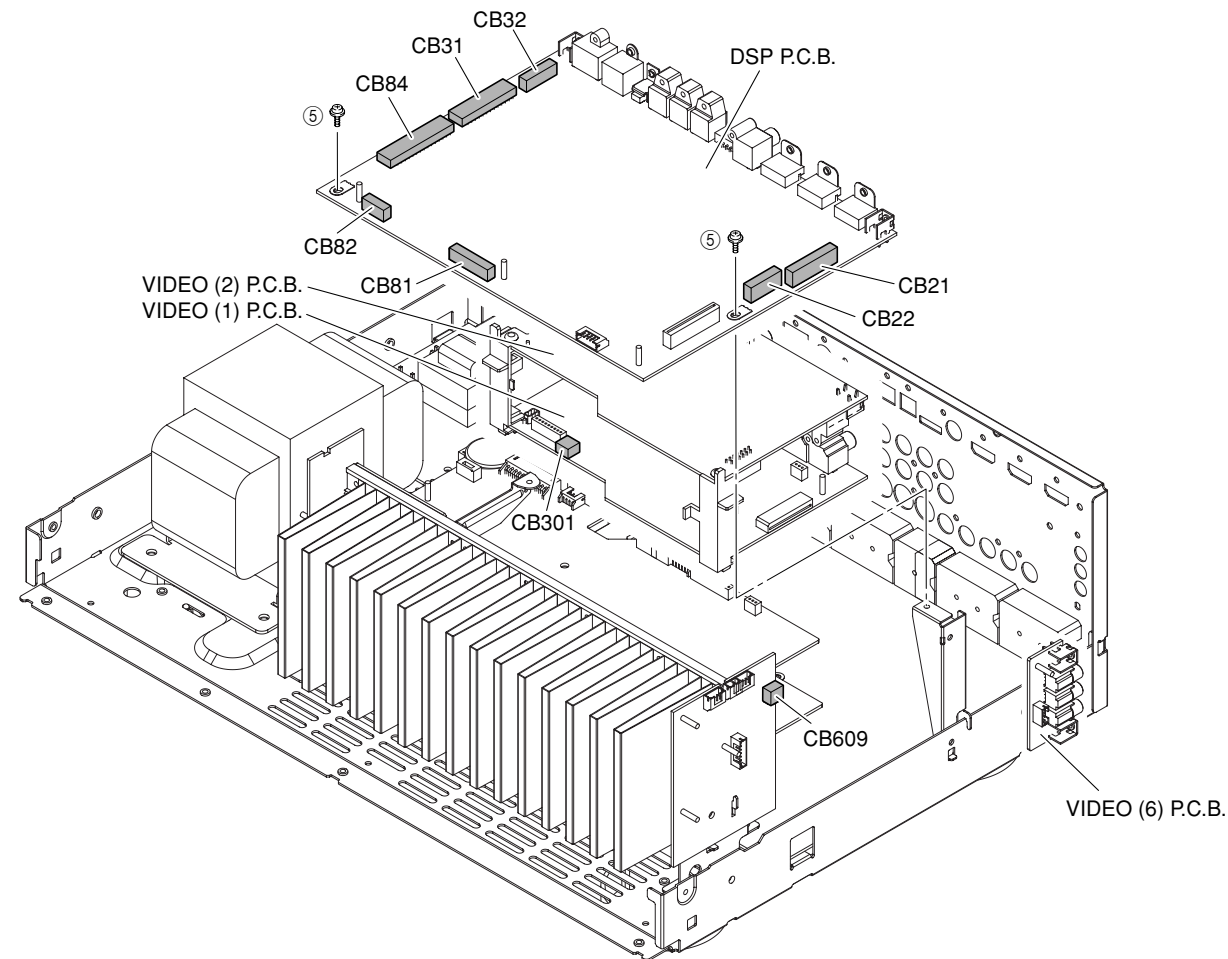

Fig. 2

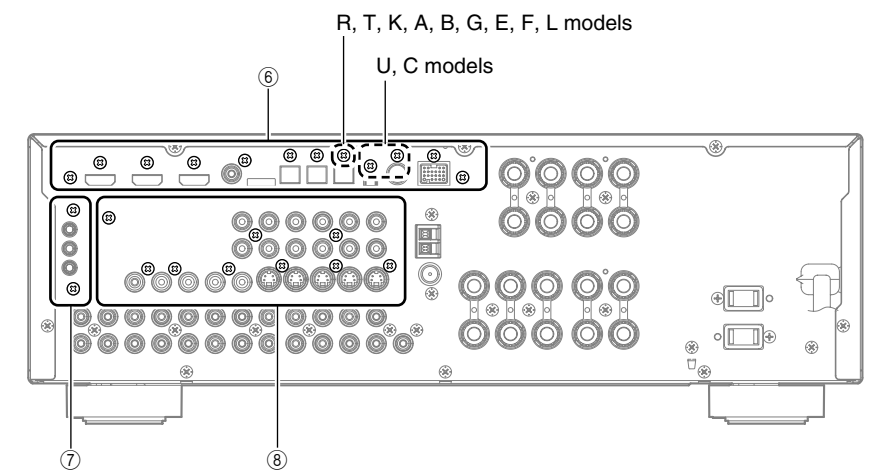

Fig. 3

### 5. Removal of VIDEO (4) P.C.B.

- Remove 2 screws (9). (Fig. 4)
- Remove CB351 and CB353. (Fig. 4)
- Remove VIDEO (4) P.C.B. (Fig. 4)

### 6. Removal of FM/AM Tuner

- Remove 2 screws (10). (Fig. 4)
- Remove CB403. (Fig. 4)
- Remove FM/AM tuner. (Fig. 4)

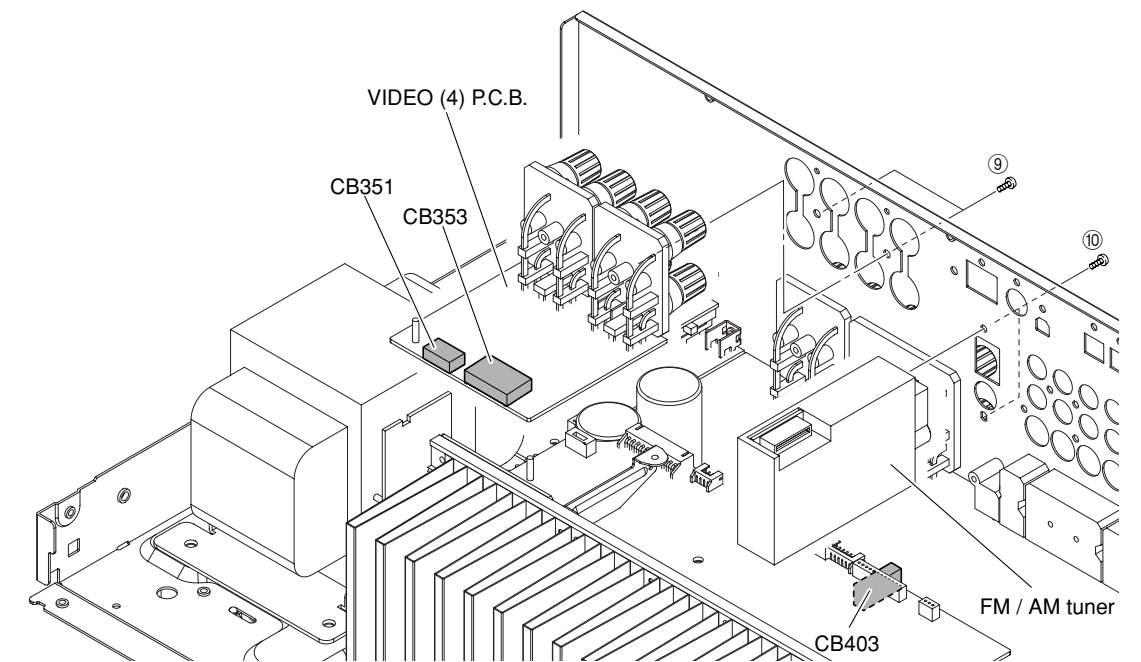

Fig. 4

**When checking the P.C.B.:**

- a. Remove the top cover. (Fig. 1)
- b. Remove DSP P.C.B.. (Fig. 2)
- c. Remove 6 screws (11). (Fig. 5)
- d. Remove 2 screws (12). (Fig. 5)
- e. Remove 3 screws (13). (Fig. 6)
- f. Remove 2 screws (14). (Fig. 5)
- g. Remove 4 screws (15). (Fig. 5)
- h. Place the P.C.B. upright. (Fig. 7)
- i. The P.C.B. removed from the chassis does not work because its grounding is loose.  
Be sure to connect the ground of rear panel and MAIN (1) P.C.B. (G5004, G5005, G5006 and G3401) and DSP P.C.B. (G801 and G802) to the chassis with a ground lead or the like. (Fig. 7)

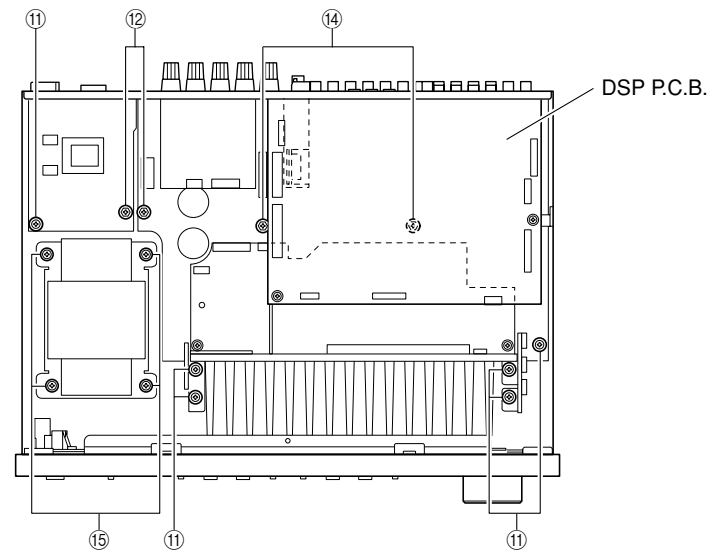

Fig. 5

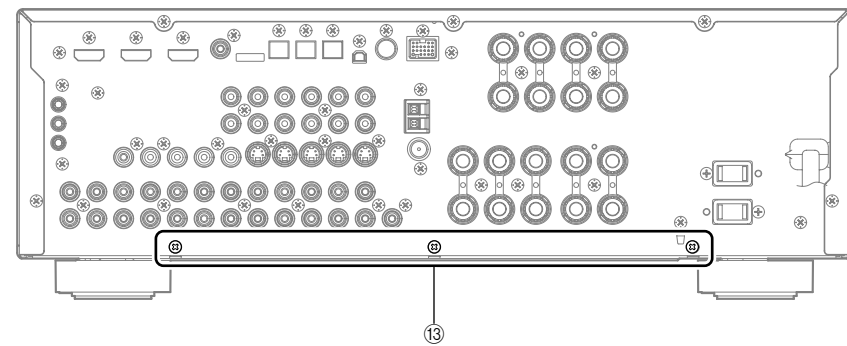

Fig. 6

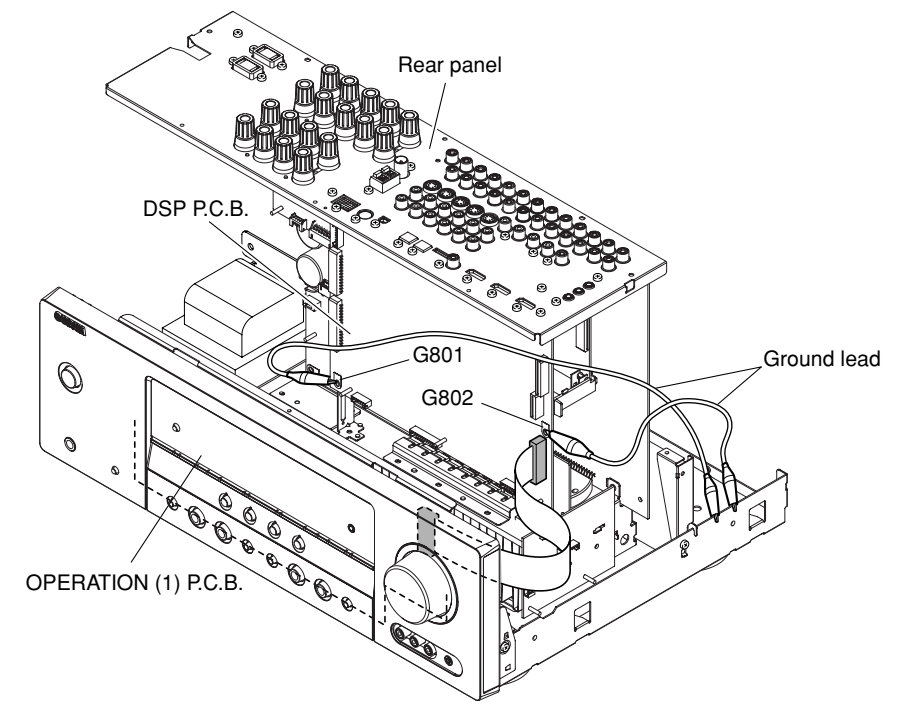
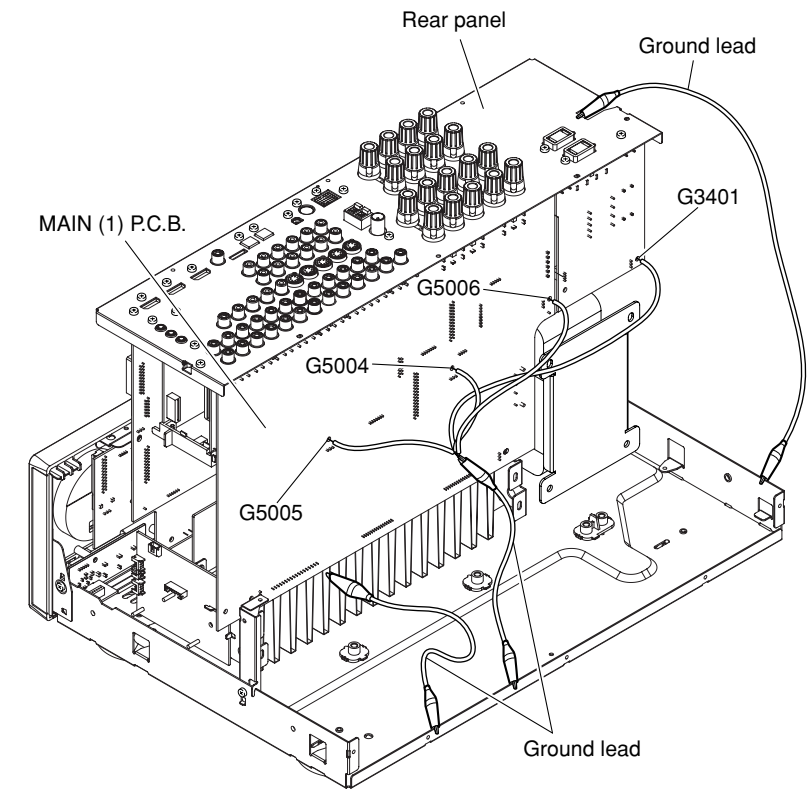

Fig. 7



## ■ UPDATING FIRMWARE

**Note:** U, C, F models

After replacement of DSP P.C.B. or writing of the firmware, make sure to activate the self-diagnostic function and change the "M6 Model ID" setting to the same model name as this unit (RX-V563 or HTR-6150).

After replacing the following parts, be sure to write the latest firmware.

- P.C.B. ass'y DSP P.C.B.
- IC52 FLASH ROM of DSP P.C.B.

### ● Required Tools

- DVD or CD player (with DIGITAL OUTPUT (OPTICAL or COAXIAL) jack)
- Optical cable (when OPTICAL jack is used)
- Digital audio pin cable (when COAXIAL jack is used)
- Firmware CD

\* To make the firmware CD, download the latest firmware from the specified download source to PC.

### ● Operation Procedures

1. Connect this unit and DVD/CD player as shown below. (Fig. 1)

#### Example of connection between digital OPTICAL jacks

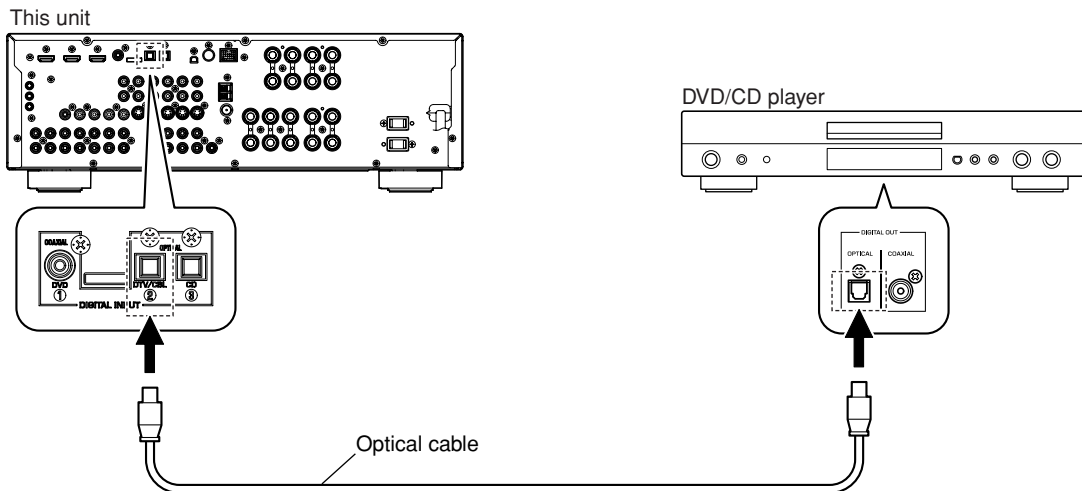

#### Example of connection between digital COAXIAL jacks

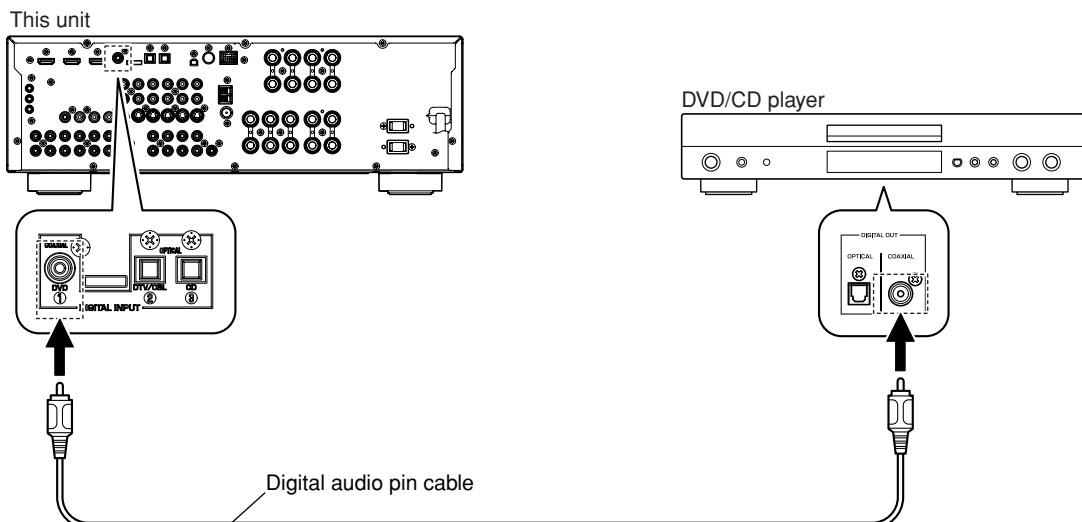

Fig. 1

- While simultaneously pressing the "MAIN ZONE ON/OFF" (RX-V563, HTR-6150) / "STANDBY/ON" (DSP-AX563) and "SPEAKERS A/B/OFF" keys of this unit, connect the power cable of this unit to the AC outlet. (Fig. 2)  
The FIRMWARE UPDATE mode is activated and "SPDIF Upgrade" is displayed. (Fig. 2)

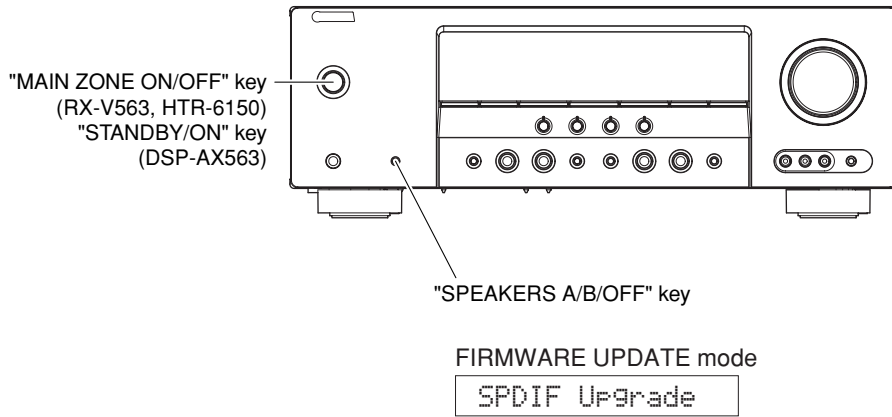

Fig. 2

- Connect the power cable of DVD/CD player to the AC outlet.
- Press the "STANDBY/ON" key of the DVD/CD player.
- Press the "EJECT" key of the DVD/CD player to open the disc tray.
- Place the firmware CD in the disc tray and close the disc tray.
- Press the "PLAY" key of the DVD/CD player.  
Then writing of the firmware is started. (Fig. 3)
- When writing of the firmware is completed, "Upgrade OK", "Please..." and "Turn off!!" are displayed repeatedly. (Fig. 3)



Fig. 3

\* When the version of the firmware to be written is the same as the one existing in this unit, "Same Version", "Please..." and "Turn off!!" are displayed repeatedly. (Upgrading is not necessary.)

If the display remains unchanged for more than 10 seconds after starting the firmware CD play procedure, perform the firmware CD play procedure again from the beginning.

If "FILE CORRUPTED" is displayed after "Address:XXXXXX", make sure that the firmware CD is not corrupted and perform steps 1 to 8 of "Operation Procedures" again.

If "Upgrade Failed" is displayed, perform Steps 1 to 8 of "Operation Procedures" again.

9. Press the "STOP" key of the DVD/CD player.
10. Press the "EJECT" key of the DVD/CD player to open the disc tray.
11. Remove the firmware CD from the disc tray and close the disc tray.
12. Turn off the power of the DVD/CD player and disconnect the power cable from the AC outlet.
13. Turn off the power by pressing the "MAIN ZONE ON/OFF" (RX-V563, HTR-6150) / "STANDBY/ON" (DSP-AX563) key of this unit.

### ● Initializing of this unit

- \* After updating the firmware, be sure to initialize this unit.
1. Connect the power cable of this unit to the AC outlet.
  2. Press the "MAIN ZONE ON/OFF" (RX-V563, HTR-6150) / "STANDBY/ON" (DSP-AX563) key while simultaneously pressing the "STRAIGHT" and "AUDIO SELECT" keys. (Fig. 4)  
The self-diagnostic function is activated.

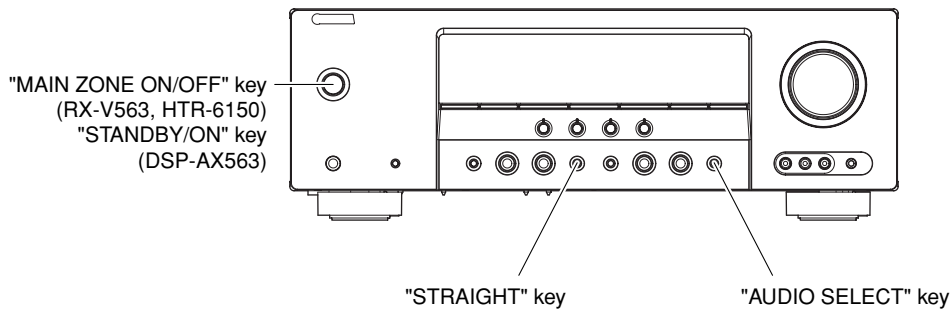

Fig. 4

3. Select the main menu "R. FACTORY PRESET".
4. Select the "PRESET RSRV".

PRESET INHIBIT (Initialization inhibited)

R1.PRESET INHI



PRESET RESERVED (Initialization reserved)

R2.PRESET RSRV

5. Turn off the power of this unit and disconnect the power cable from the AC outlet.

● **Confirmation of firmware version and checksum**

To confirm that the firmware is updated successfully, check the firmware version and checksum value by using the self-diagnostic function menu "S. ROM VER/SUM".

For more information, refer to "SELF-DIAGNOSTIC FUNCTION".

\* When the displayed firmware version and checksum are different from written firmware version and checksum, follow the steps from 1 to 13 of "Operation Procedures" again.

1. Reconnect the power cable of this unit to the AC outlet.
2. Press the "MAIN ZONE ON/OFF" (RX-V563, HTR-6150) / "STANDBY/ON" (DSP-AX563) key while simultaneously pressing the "STRAIGHT" and "AUDIO SELECT" keys. (Fig. 5)  
Then the self-diagnostic function is activated.
3. Select the self-diagnostic function menu "S1. Version".  
Confirm the displayed firmware version is the same as the written firmware version. (Fig. 5)

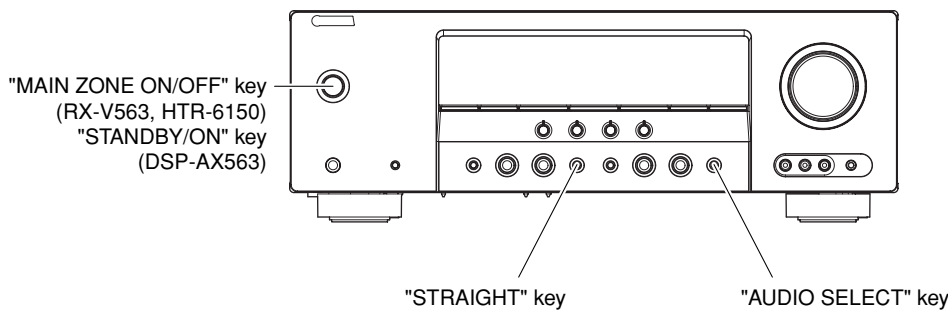

Example:



Fig. 5

4. Select the self-diagnostic function menu "S2. All checksum/S3. Program checksum".  
Confirm the displayed checksum is the same as the written firmware checksum. (Fig. 6)  
(The checksum value is found where downloading is specified to.)

Example:

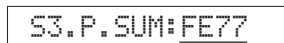

Fig. 6

5. Turn off the power of this unit and disconnect the power cable from the AC outlet.

● **Confirmation of model name (U, C, F models)**

After replacement of DSP P.C.B. or writing of the firmware, make sure to activate the self-diagnostic function and change the "M6 Model ID" setting to the same model name as this unit (RX-V563 or HTR-6150).

1. Connect the power cable of this unit to the AC outlet.
2. Press the "MAIN ZONE ON/OFF" (RX-V563, HTR-6150) / "STANDBY/ON" (DSP-AX563) key while simultaneously pressing the "STRAIGHT" and "AUDIO SELECT" keys. (Fig. 7)  
The self-diagnostic function is activated.
3. Select the self-diagnostic function menu "M6. Model ID".

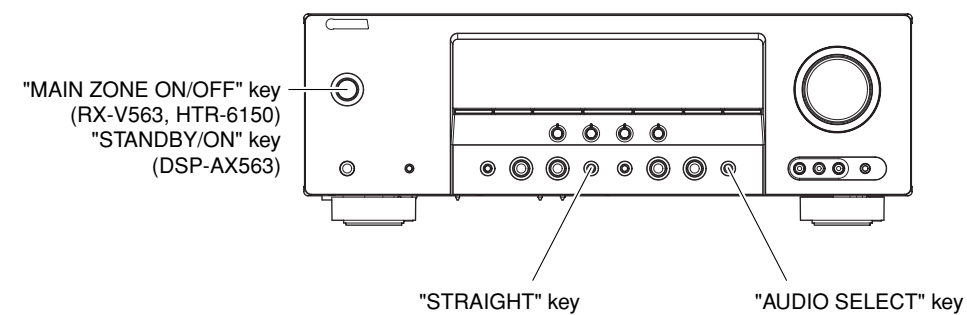

Fig. 7

4. Press "PRESET/TUNING<" or "PRESET/TUNING>" key and select the model name.

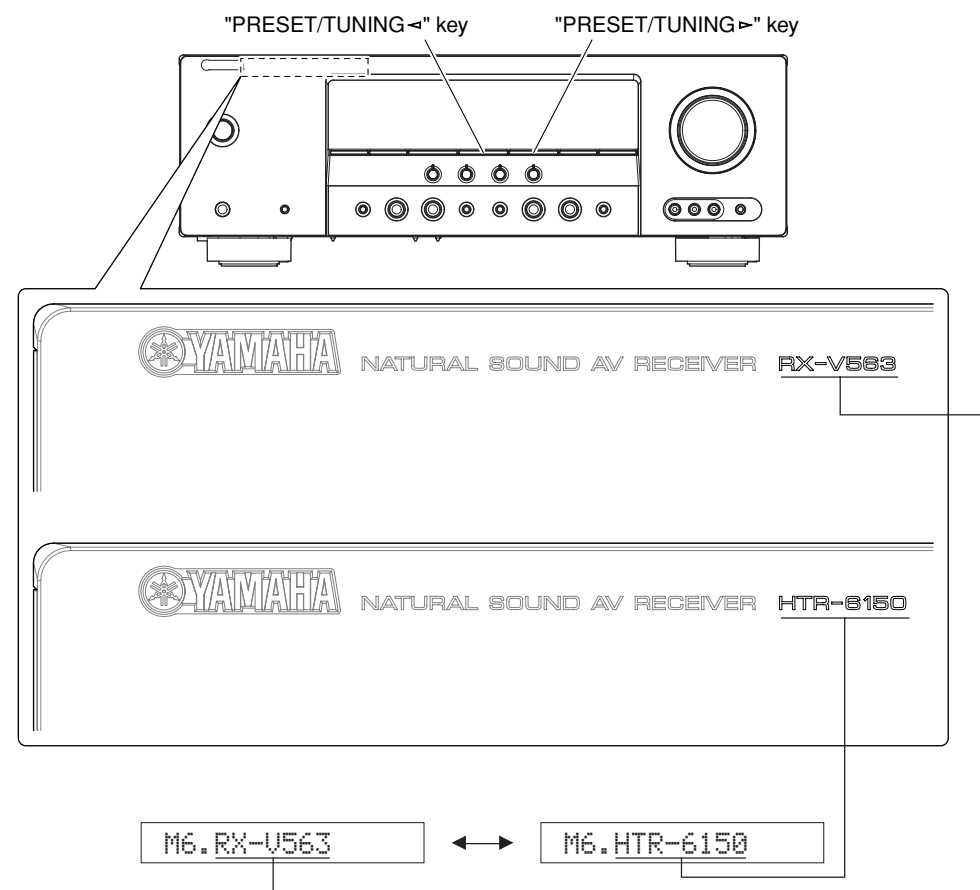

Fig. 8

## ■ SELF-DIAGNOSTIC FUNCTION

This unit has self diagnosis functions that are intended for inspection, measurement and location of faulty point.

There are 19 main menu items, each of which has sub-menu items.

Listed in the table below are menu items and sub-menu items.

Note that not all menu items listed will apply to the models covered in this service manual.

No.	Main menu	Sub-menu
A	BYPASS	1 ANLOG BYPAS 2 DSP BYPASS
B	AUDIO CHECK	1 AUDIO CHECK 2 ANALOG AUDIO PLAYBACK 3 MUTE ALL 4 MUTE SYS IC 5 MUTE TR
C	SPEAKERS SET	1 FRNT : SML0dB 2 CENTER : NONE 3 LFE/B : FRNT 4 TONE : MAX 5 TONE : MIN
D	XCH-INPUT	1 6chINPUT 6Ω 2 8chINPUT 6Ω 3 6chINPUT 8Ω 4 8chINPUT 8Ω 5 LIM : PLDET : THM (ex. 05.255:255: 64)
E	MIC CHECK	1 MIC CHECK
F	FL/OSD CHECK	1 VFD CHECK 2 VFD DISP OFF 3 VFD DISP ALL 4 VFD DIMMER 5 CHECK PATTERN
G	TEST TONE	1 TEST ALL 2 TEST FRNT L 3 TEST CENTER 4 TEST FRNT R 5 TEST SURR R 6 TEST SURB R 7 TEST SURB L 8 TEST SURR L 9 TEST LFE
H	XM STATUS (U, C models)	1 1k - 1dB/44 2 1k -61dB/44 3 MUTE /44 4 XM TONE/44 5 ISO TONE/44 6 1k - 1dB/32 7 1k -61dB/32 8 MUTE /32 9 XM TONE/32 10 ISOTONE/32 11 BUSPWR (BUS power) : OFF
I	iPod	1 DOCK : xx xxx 2 DOCK IGNORE 3 Bluetooth version 4 Clear Bluetooth pairing info.
J	USB (R, T, K, A, B, G, E, F, L models)	1 USBFile1/xx 2 USBFile2/xx 3 High Speed TEST_PACKET mode 4 High Speed TEST_SE0_NAK mode
K	SIRIUS (U, C models)	1 SIRIUS connection check 2 SIRIUS antenna status 3 SIRIUS loop back test 4 SIRIUS SSP version display (only for SIRIUS certification engineer) 5 SIRIUS firmware #1 version display (only for SIRIUS certification engineer) 6 SIRIUS Firmware #2 version display (only for SIRIUS certification engineer) 7 SIRIUS FW product_id version display (only for SIRIUS certification engineer) 8 SIRIUS FW sequence_id version display (only for SIRIUS certification engineer)

No.	Main menu	Sub-menu
L	VIDEO CONVERSION	1 V-IN (Video info.) 2 V-CONV S-V (Conversion S-video) 3 V-CONV CVBS (Conversion CVBS) 4 V-CONV OFF (Conversion OFF) 5 V-TestPtn (Video test pattern)
M	HDMI Check	1 HDMI SPDIF (SPDIF audio playback) 2 HDMI NONE 3 HDMI IN1 4 HDMI IN2 5 I2C : xx xxx (I2C access check) 6 Model ID for EDID setting
N	AD DATA CHECK	1 PD : xxx DI : xxx (ex. N1PD: 45DI: 0) 2 V1 : xxx V2 : xxx (ex. N2V1: 94V2:128) 3 TH : xxx PL : xxx (ex. N3TH: 64PL:255) 4 PI : xxx DE : xxx (ex. N4PI: 0DE: 0) 5 K0 : xxx K1 : xxx (ex. N5K0:254K1:254)
O	PROTECTION	1 PRD : xxx/xxx (ex. 01.PRD: 23/ 70) 2 PV1 : xxx/xxx (ex. 02.PV1: 68/161) 3 PV2 : xxx/xxx (ex. 03.PV2:104/181) 4 THM : xxx/xxx (ex. 04. THM: 0/131) 5 L66 : xxx/xxx (PLDET 6ch 6ohms : xxx/xxx) (ex. 05.L66: 0/ 0) 6 L86 : xxx/xxx (PLDET 8ch 6ohms : xxx/xxx) (ex. 06.L86: 0/ 0) 7 L68 : xxx/xxx (PLDET 6ch 8ohms : xxx/xxx) (ex. 07.L68: 0/ 0) 8 L88 : xxx/xxx (PLDET 8ch 8ohms : xxx/xxx) (ex. 08.L88: 0/ 0) 9 PRI : xxx/xxx (PRI : xxx/xxx) (ex. 09.PRI: 0/100) 10 PDE : xxx/xxx (PDET : xxx/xxx) (ex. 010PDE: 0/255)
P	PROTECTION HIST.	1 History 1 (ex. PRU: xxx) 2 History 2 (ex. THM: xxx) 3 History 3 (ex. PRI: xxx) 4 History 4
Q	RESERVED	
R	FACTORY PRESET	1 PRESET INHI 2 PRESET RSRV
S	ROM VER/SUM	1 Microprocessor version 2 All checksum 3 Program checksum 4 SPI checksum 5 SPD checksum 6 XM version (U, C models) 7 SIRIUS version (U, C models) 8 FlashROM test 9 SDRAM test 10 EEPROM test

## • Starting Self-diagnostic Function

Press the “MAIN ZONE ON/OFF” (RX-V563, HTR-6150) / “STANDBY/ON” (DSP-AX563) key while simultaneously pressing those two keys of this unit as indicated in the figure below.

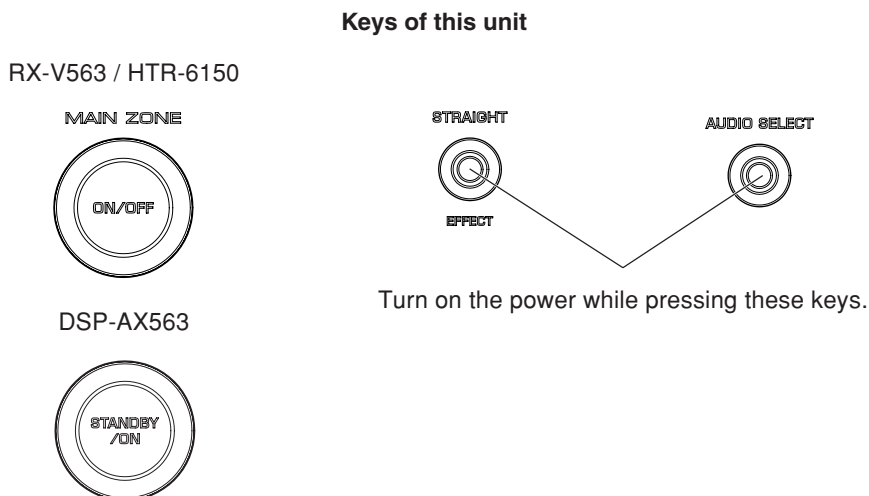

## • Starting Self-diagnostic Function in the protection cancel mode

If the protection function works and causes hindrance to trouble diagnosis, cancel the protection function as described below, and it will be possible to enter the self-diagnostic function mode. (The protection functions other than the excess current detect function will be disabled.)

Press the “MAIN ZONE ON/OFF” (RX-V563, HTR-6150) / “STANDBY/ON” (DSP-AX563) key while simultaneously pressing those two keys indicated in the figure above. At this time, keep pressing those two keys for 3 seconds or longer. In this mode, the [SLEEP] segment of the FL display of this unit flashes to indicate that the mode is self-diagnostic function mode with the protection functions disabled.

### **CAUTION!**

**Using this product with the protection function disabled may cause damage to this unit. Use special care for this point when using this mode.**

## • Canceling Self-diagnostic Function

1. Before canceling self-diagnostic function, execute setting for FACTORY PRESET of main menu No.R (Memory initialization inhibited or Memory initialized).
  - \* In order to keep the user memory stored, be sure to select PRESET INHIBITED (Memory initialization inhibited).
2. Turn off the power by pressing the “MAIN ZONE ON/OFF” (RX-V563, HTR-6150) / “STANDBY/ON” (DSP-AX563) key of this unit.

## • Display provided when Self-diagnostic Function started

On the FL display of this unit, an opening message (including the protection history) appears for a few seconds followed by the self-diagnostic function menu display (1. ANALOG BYPASS).

**When there is no history of protection function:**

When there is no protection history



After a few seconds

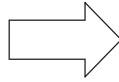

**When there is a history of protection function due to excess current**



AD value when the protection function is working

**Cause:** An excessive current flowed through the power amplifier.

**Supplementary information:**

As current of the power amplifier is detected, the abnormal channel can be identified by checking the current detect transistor.

Turning on the power without correcting the abnormality will cause the protection function to work immediately and the power supply will instantly be shut off.

**Note)**

- Applying the power to this unit without correcting the abnormality can be dangerous and cause additional circuit damage. To avoid this, if “PRI” and “PRD” protection function has been activated 3 times continuously, the power will not turn on even when the “STANDBY/ON” key is pressed. In order to turn on the power again, disconnect the power cable of this unit from the AC outlet once and then reconnect it again.
- The output transistors in each power amplifier channel should be checked for damage before applying power to this unit.
- Power amplifier current should be monitored by measuring DC voltage across the emitter resistors for each channel.

**When there is a history of protection function due to abnormal DC output**



AD value when the protection function is working

**Cause:** DC output of the power amplifier is abnormal.

**Supplementary information:**

The protection function worked due to a DC voltage appearing at the speaker terminal.

A cause could be a defect in the amplifier.

If the power is turned on with the abnormality unsolved, the protection function works in 3 seconds to turn off the power.

RX-V563/HTR-6150/  
DSP-AX563



**When there is a history of protection function due to abnormal voltage in the power supply section**

PRV1 PRT:xxx

AD value when the protection function is working

**Cause:** The voltage in the power supply section is abnormal.**Supplementary information:**

The protection function worked due to a defect or overload in the power supply.

If the power is turned on with the abnormality unsolved, the protection function works in 1 second to turn off the power.

**When there is a history of protection function due to abnormal voltage in the power supply section**

PRV2 PRT:xxx

AD value when the protection function is working

**Cause:** The voltage in the power supply section is abnormal.**Supplementary information:**

The protection function worked due to a defect or overload in the power supply.

If the power is turned on with the abnormality unsolved, the protection function works in 1 second to turn off the power.

**When there is a history of protection function due to excessive heat sink temperature**

THM PRT:xxx

AD value when the protection function is working

**Cause:** The temperature of the heat sink is excessive.**Supplementary information:**

The protection function worked due to the temperature limit being exceeded.

Causes could be poor ventilation or a defect related to the thermal sensor.

If the power is turned on with the abnormality unsolved, the protection function works in 1 second to turn off the power.  
For detection of each protection function, refer to main menu described later.

**History of protection function**

When the protection function has worked, its history is stored in memory with a backup.

Even if no abnormality is noted while servicing the unit, an abnormality which has occurred previously can be defined as long as the backup data has been stored.

The history of the protection function is cleared when self-diagnostic function is cancelled by selecting PRESET RESERVED (Memory initialized) of main menu No. R or when the backup data is erased.

## • Operation procedure of Main menu and Sub-menu

There are 19 main menu items, each of having sub-menu items.

### Main menu selection:

Select the main menu using “▶” (forward) and “◀” (reverse) keys of PROGRAM.

### Sub-menu selection:

Select the sub-menu using “SCENE 2” (forward) and “SCENE 1” (Reverse) keys.

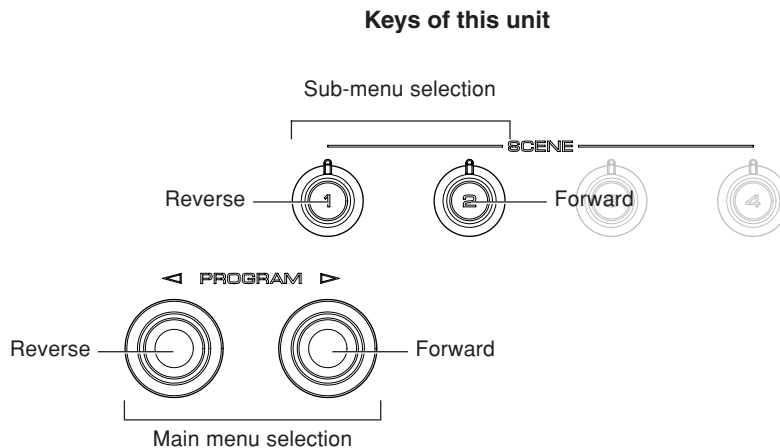

## • Functions in Self-Diagnostic Function mode

In addition to the self-diagnostic function menu items, functions as listed below are available.

- Power on/off
- Master volume
- Muting
- Speakers A/B/OFF
- Input selection
- Audio select
- Tone control
- \* Functions related to the tuner and the set menu are not available.

## • Initial settings used to start Self-Diagnostic Function

The following initial settings are used when starting self-diagnostic function.

When self-diagnostic function is canceled, these settings are restored to those before starting self-diagnostic function.

- Master volume: -20 dB
- Input: DVD (MULTI CHANNEL INPUT OFF)
- Effect level: 0 dB
- Main menu: 1. ANALOG BYPASS

• **Details of Self-Diagnostic Function menu**

**A. BYPASS**

Using the sub-menu, it is possible to select ANALOG BYPASS output or DSP BYPASS output.

**ANALOG BYPASS**

The analog input sound signal is output to FRONT L/R with EFFECT OFF.

A1.ANLOG BYPAS

INPUT: DVD ANALOG  
SPEAKER OUT: 1 kHz, SUBWOOFER OUTPUT: 50 Hz

Input level	Volume	SPEAKER OUT			SUBWOOFER OUTPUT
		FRONT	CENTER	SURROUND	
Both ch, -20 dBm	+6.0 dB	+11.5 dBm	-∞	-∞	-∞

**DSP BYPASS**

The digital input sound signal is output to FRONT L/R with EFFECT OFF.

A2.DSP BYPASS

INPUT: DVD ANALOG  
SPEAKER OUT: 1 kHz, SUBWOOFER OUTPUT: 50 Hz

Input level	Volume	SPEAKER OUT			SUBWOOFER OUTPUT
		FRONT	CENTER	SURROUND	
Both ch, -20 dBm	+6.0 dB	+11.5 dBm	-∞	-∞	-∞

**B. AUDIO CHECK**

**AUDIO CHECK**

The input sound signal is output.

\* When the inputted sound signal is 2 ch L/R, it is distributed as follows when output.

**L ch:** FRONT L, CENTER, SURROUND L, LFE ( L ch +10 dB)

**R ch:** SURROUND R

B1.AUDIO CHECK

INPUT: DVD ANALOG  
SPEAKER OUT: 1 kHz, SUBWOOFER OUTPUT: 50 Hz

Input level	Volume	SPEAKER OUT			SUBWOOFER OUTPUT
		FRONT	CENTER	SURROUND	
Both ch, -20 dBm	+6.0 dB	+11.5 dBm	+11.5 dBm	+11.5 dBm	0 dBm

**ANALOG AUDIO PLAYBACK**

The input sound signal is output.

B2.ANALOG PLAY

**MUTE SYSTEM IC**

Sound signals of all channels are muted by System IC (MAIN P.C.B.).

B4.MUTE SYS IC

**MUTE ALL**

Sound signals of all channels are muted by System IC (MAIN P.C.B.) and Transistor (Q5008-5011 MAIN P.C.B.).

B3.MUTE ALL

**MUTE TRANSISTOR**

Sound signals of all channels are muted by Transistor (Q5008-5011 MAIN P.C.B.).

B5.MUTE TR

RX-V563/HTR-6150/  
DSP-AX563

**C. SPEAKER SET**

The analog switch settings for each sub-menu are as shown in the table below.

FRONT : SML 0dB	SMALL	LARGE	LARGE	SWFR
CENTER : NONE	LARGE	NONE	LARGE	SWFR
LFE/B : FRNT	LARGE	SMALL	SMALL	FRONT
TONE : MAX	LARGE	LARGE	LARGE	SWFR
TONE : MIN	LARGE	LARGE	LARGE	SWFR

- LARGE:** This mode is used for a speaker with high bass reproduction performance (a large unit). Full bandwidth signals are output.
- SMALL:** This mode is used for a speaker with low bass reproduction performance (a small unit). The signals of 90 Hz or less are mixed into the channel specified by LFE/BASS.
- NONE:** This mode is used for no center speaker. The center content is reduced by 3 dB and distributed to FRONT L/R.
- SWFR:** LFE of 5.1 ch signal or LFE/BASS lower than 90 Hz is output through SUBWOOFER OUT.
- FRONT:** LFE of 5.1 ch signal or LFE/BASS lower than 90 Hz is distributed to FRONT L/R.

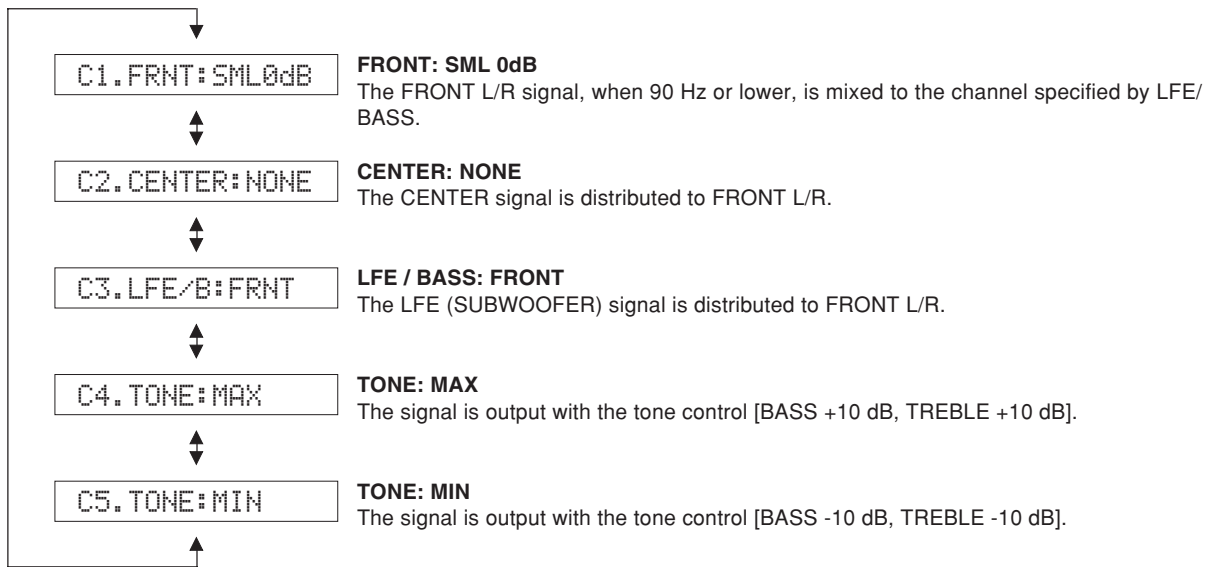

INPUT: DVD ANALOG  
SPEAKER OUT: 1 kHz, SUBWOOFER OUTPUT: 50 Hz

Sub-menu	Input level	Volume	SPEAKER OUT			SUBWOOFER OUTPUT
			FRONT	CENTER	SURROUND	
FRONT : SML 0dB	Both ch, -20 dBm	+6.0 dB	+11.5 dBm	-∞	-∞	-3.5 dBm
CENTER : NONE	Both ch, -20 dBm	+6.0 dB	+11.5 dBm	-∞	-∞	-∞
LFE/B : FRNT	Both ch, -20 dBm	+6.0 dB	+11.5 dBm	-∞	-∞	-∞
TONE : MAX	Both ch, -20 dBm	+6.0 dB	+14.5 dBm	-∞	-∞	-∞
TONE : MIN	Both ch, -20 dBm	+6.0 dB	+8.5 dBm	-∞	-∞	-∞

RX-V563/HTR-6150/DSP-AX563

**D. XCH INPUT**

The input source [MULTI CHANNEL INPUT] is selected.  
It is possible to select the 6-ohm/8-ohm by using the sub-menu.

**6 ch INPUT 6-ohm**

D1.6chINPUT 6Ω

INPUT: MULTI CH INPUT  
SPEAKER OUT: 1 kHz, SUBWOOFER OUTPUT: 50 Hz

Sub-menu	Input level	Volume	SPEAKER OUT			SUBWOOFER OUTPUT
			FRONT	CENTER	SURROUND	
6 ch INPUT 6-ohm	Both ch, -20 dBm	+6.0 dB	+11.5 dBm	+11.5 dBm	+11.5 dBm	-3.5 dBm

**8 ch INPUT 6-ohm**

D2.8chINPUT 6Ω

INPUT: MULTI CH INPUT  
SPEAKER OUT: 1 kHz, SUBWOOFER OUTPUT: 50 Hz

Sub-menu	Input level	Volume	SPEAKER OUT			SUBWOOFER OUTPUT
			FRONT	CENTER	SURROUND	
6 ch INPUT 8-ohm	Both ch, -20 dBm	+6.0 dB	+11.5 dBm	+11.5 dBm	+11.5 dBm	-3.5 dBm

**6 ch INPUT 8-ohm**

D3.6chINPUT 8Ω

INPUT: MULTI CH INPUT  
SPEAKER OUT: 1 kHz, SUBWOOFER OUTPUT: 50 Hz

Sub-menu	Input level	Volume	SPEAKER OUT			SUBWOOFER OUTPUT
			FRONT	CENTER	SURROUND	
6 ch INPUT 8-ohm	Both ch, -20 dBm	+6.0 dB	+11.5 dBm	+11.5 dBm	+11.5 dBm	-3.5 dBm

**8 ch INPUT 8-ohm**

D4.8chINPUT 8Ω

INPUT: MULTI CH INPUT  
SPEAKER OUT: 1 kHz, SUBWOOFER OUTPUT: 50 Hz

Sub-menu	Input level	Volume	SPEAKER OUT			SUBWOOFER OUTPUT
			FRONT	CENTER	SURROUND	
6 ch INPUT 8-ohm	Both ch, -20 dBm	+6.0 dB	+11.5 dBm	+11.5 dBm	+11.5 dBm	-3.5 dBm

**LIM/PLDET/THM**

**LIM:** Setting value of LIM (Limiter control)

\* Do not change the setting value because this item is only for the use of development staff.

**PLDET:** Power limiter detection  
The A/D conversion value during operation is displayed.

**THM:** Thermo protection detection  
The A/D conversion value during operation is displayed.  
(Reference voltage: 3.3 V=255)

D5.255:255: 64

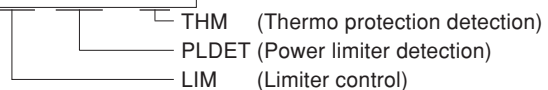

RX-V563/HTR-6150/DSP-AX563

**E. MIC CHECK**

The signals input through the microphone are output of FRONT L/R via A/D and D/A.

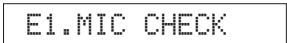

**F. FL CHECK**

Use this program to check the FL display section and video control section. When checking the video control section, connect a TV monitor to this unit with a component video cable, S video cable and video pin cable. Selection of the FL display section or video control section varies according to the submenu operation as shown below.

For audio signal processing, use STRAIGHT.

**Checking FL display section**

**Check of the Video control section. (Monitor out)**

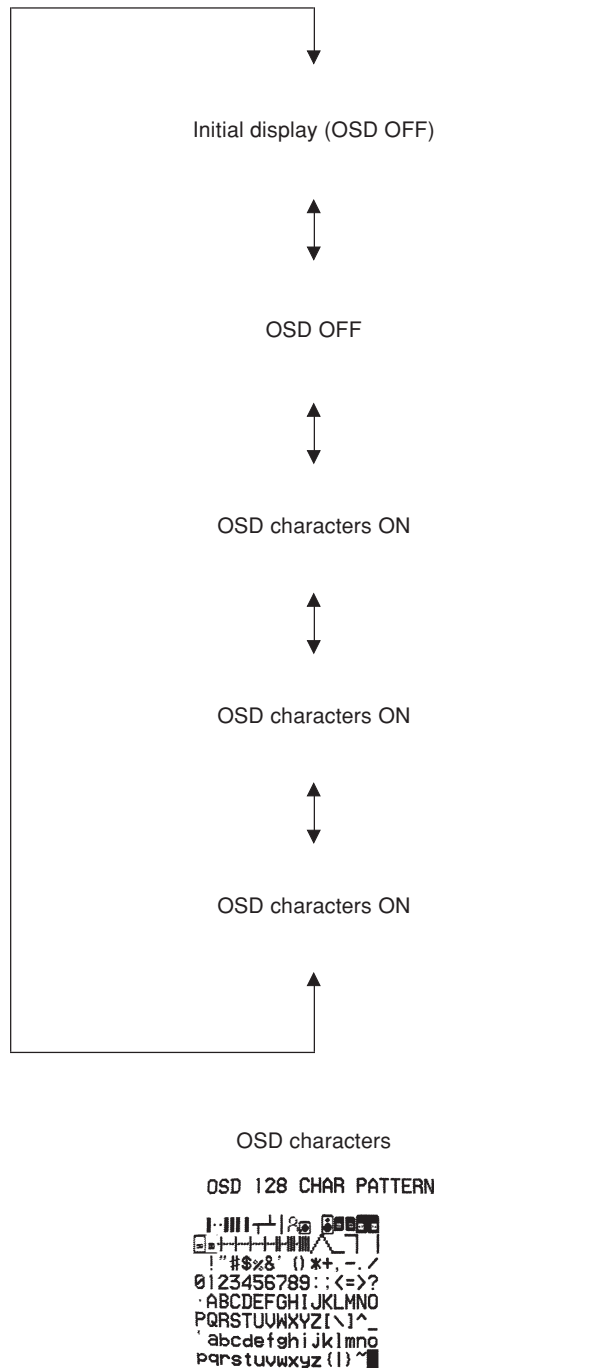
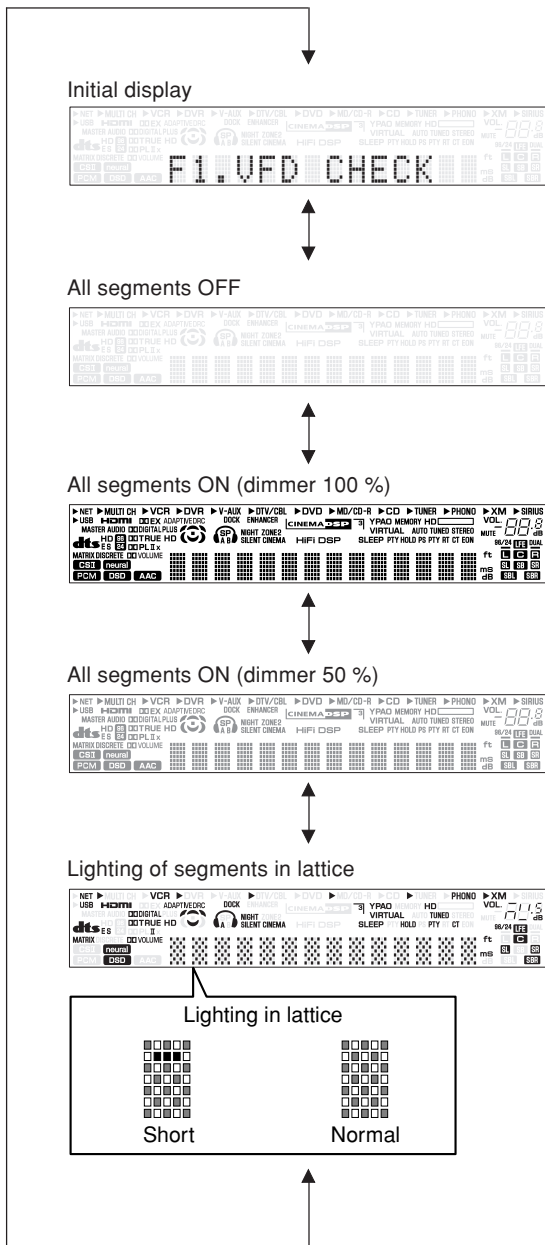

RX-V563/HTR-6150/DSP-AX563

## G. TEST TONE

The outputs the noise through the channels specified by the submenu.

The noise frequency for LFE (SUBWOOFER) is 35 to 80 Hz.

Other than that, the noise frequency is 500 to 2 kHz.

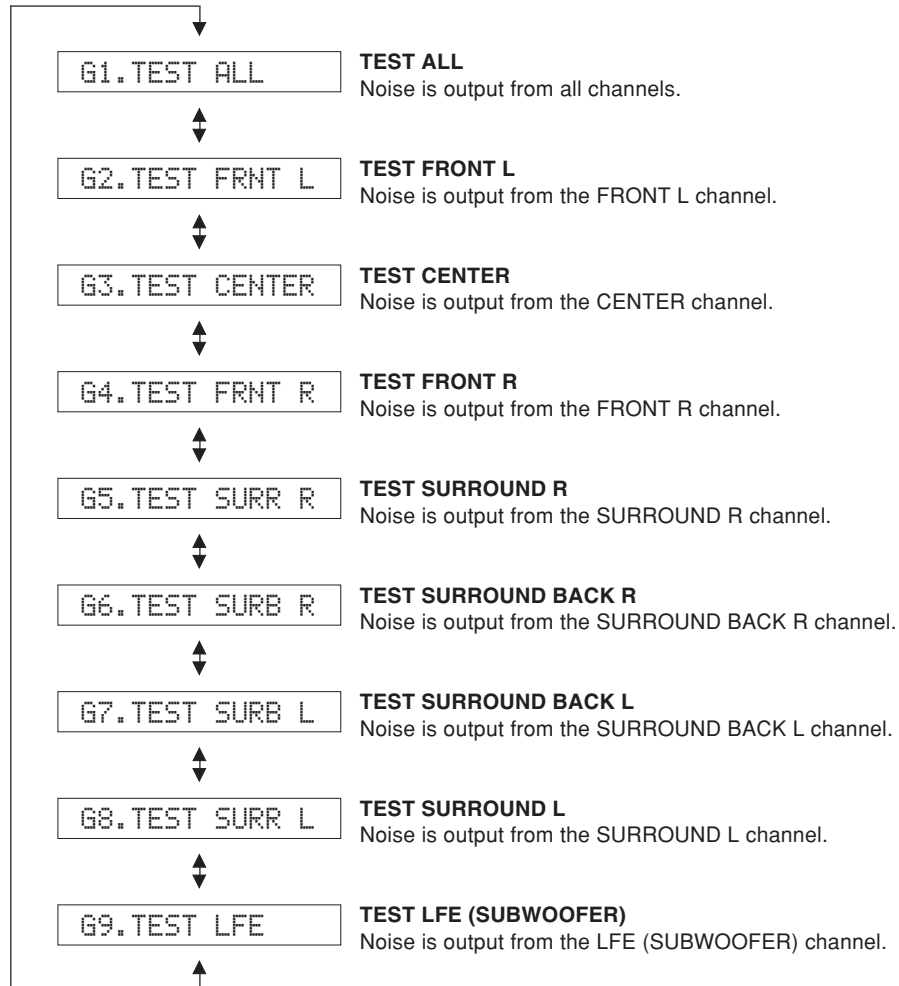

**H. XM STATUS (U, C models)**

The output check of XM radio is executed.  
 (Connect XM radio antenna module to this unit before executing.)

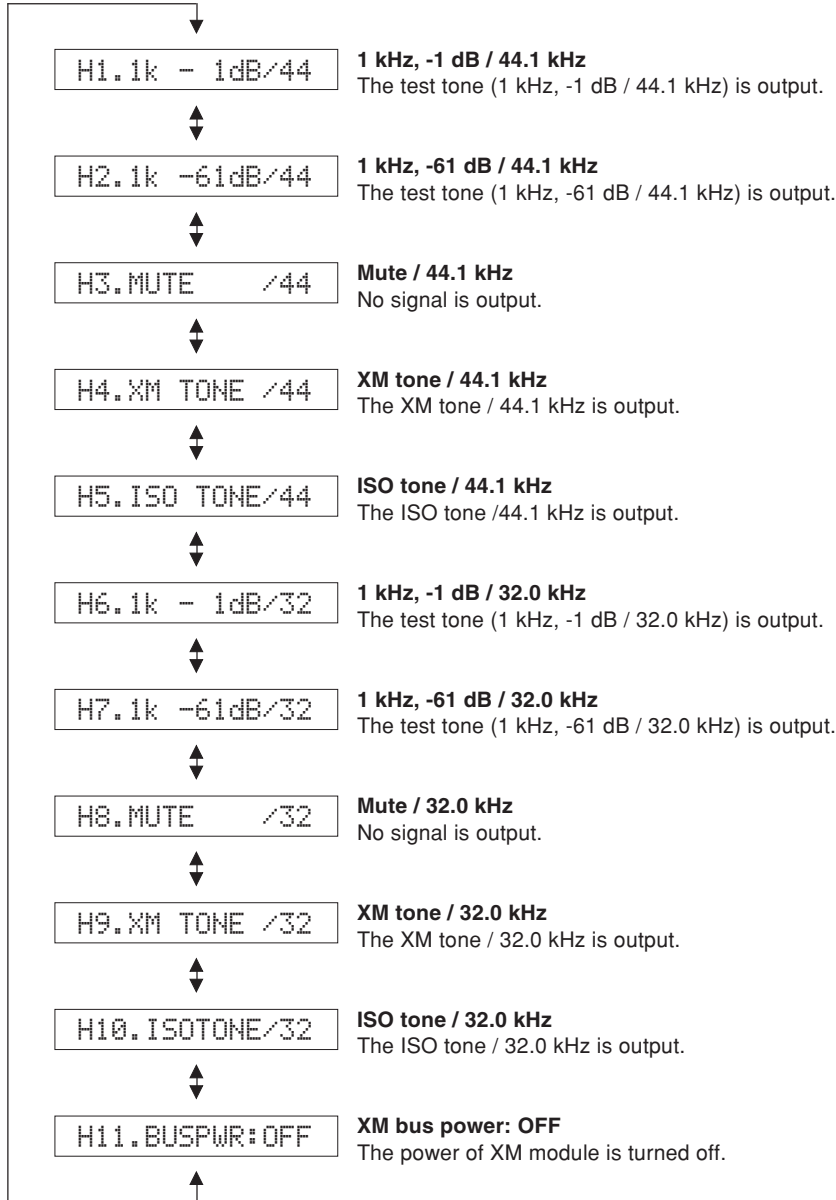

RX-V563/HTR-6150/  
 DSP-AX563



**I. iPod**

This menu is used to test the DOCK connector without the iPod itself. After turning off the power to this unit short between pins No. 14 (TX) and No. 18 (RX), between pins No. 1 (PWR) and No. 17 (ACCPW), between pins No. 4 (iPDET) and No. 8 (DGND) and between pins No. 21 (DKID) and No. 8 (DGND) of the DOCK connector. (Make sure that the power is turned off when shorting pins.)

Start the self-diagnostic function and select this menu.

The check result is displayed according to the following display specifications.

**Note) Be sure to return the shorted pins to their original condition after executing this test.**

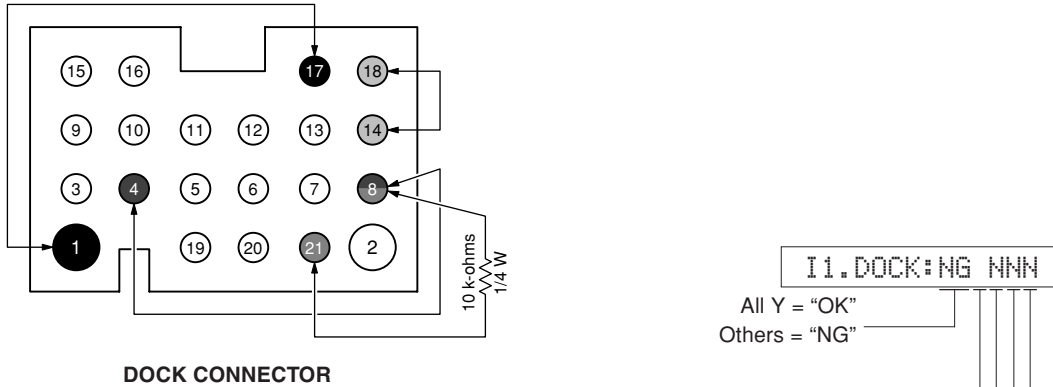

Check item	Result		Display
UART loop back test	OK		Y
	NG		N
iPAP (iPod accessory power) detection	IC83	High	Y
	pin No.5	Low	N
iPDET (iPod installation to DOCK) detection	IC82	Low (iPod universal dock)	Y
	pin No.5	High (Bluetooth adapter)	N
DKID (DOCK ID) detection	IC82	10 k-ohms, 1/4 W pull down	Y
	pin No.4	Other	N

**DOCK ignore**

When DOCK and iPod are connected, the input source [DOCK (iPod)] is made ineffective and [V-AUX] is selected.

I2.DOCK IGNORE

**Bluetooth version**

When the Bluetooth DOCK is connected, the firmware version of that Bluetooth module is displayed.

I3.BTYS:x.xxx

**Clear Bluetooth pairing information**

While the Bluetooth DOCK is connected, initialization of the Bluetooth DOCK pairing information is inhibited/reserved. Use "PRESET/TUNING<" and "PRESET TUNING>" keys for operation.

**Initialization inhibited**

I4.BT CLR: INHI



**Initialization reserved**

I4.BT CLR: RSRV

**Initialization inhibited**

User memory initialization is not executed. Select this sub-menu to protect the user memory.

**Initialization reserved**

Initialization of the use memory is reserved. (Actually, initialization is executed the next time that the power is turned on.) Select this sub-menu to reset to the original factory settings or to reset the use memory. Any protection history will be cleared.

**J. USB (R, T, K, A, B, G, E, F, L models)**

The music file recorded in the USB flash memory is reproduced.

- a. Copy the 2 music files from PC into the root folder of the USB flash memory.
- b. Insert the USB flash memory to the USB terminal of this unit.

**USB FILE1**

Reproduced at this time is the first piece of the music file in the USB flash memory connected to the USB terminal on the front panel.

J1.USBFile1/OK

OK: Connected/Playback  
NG: No music file

**USB FILE2**

Reproduced at this time is the second piece of the music file in the USB flash memory connected to the USB terminal on the front panel.

J2.USBFile2/OK

OK: Connected/Playback  
NG: No music file

RX-V563/HTR-6150/  
DSP-AX563

**K. SIRIUS (U, C models)**

The SIRIUS antenna module is checked.

(Connect SIRIUS antenna module to this unit before executing.)

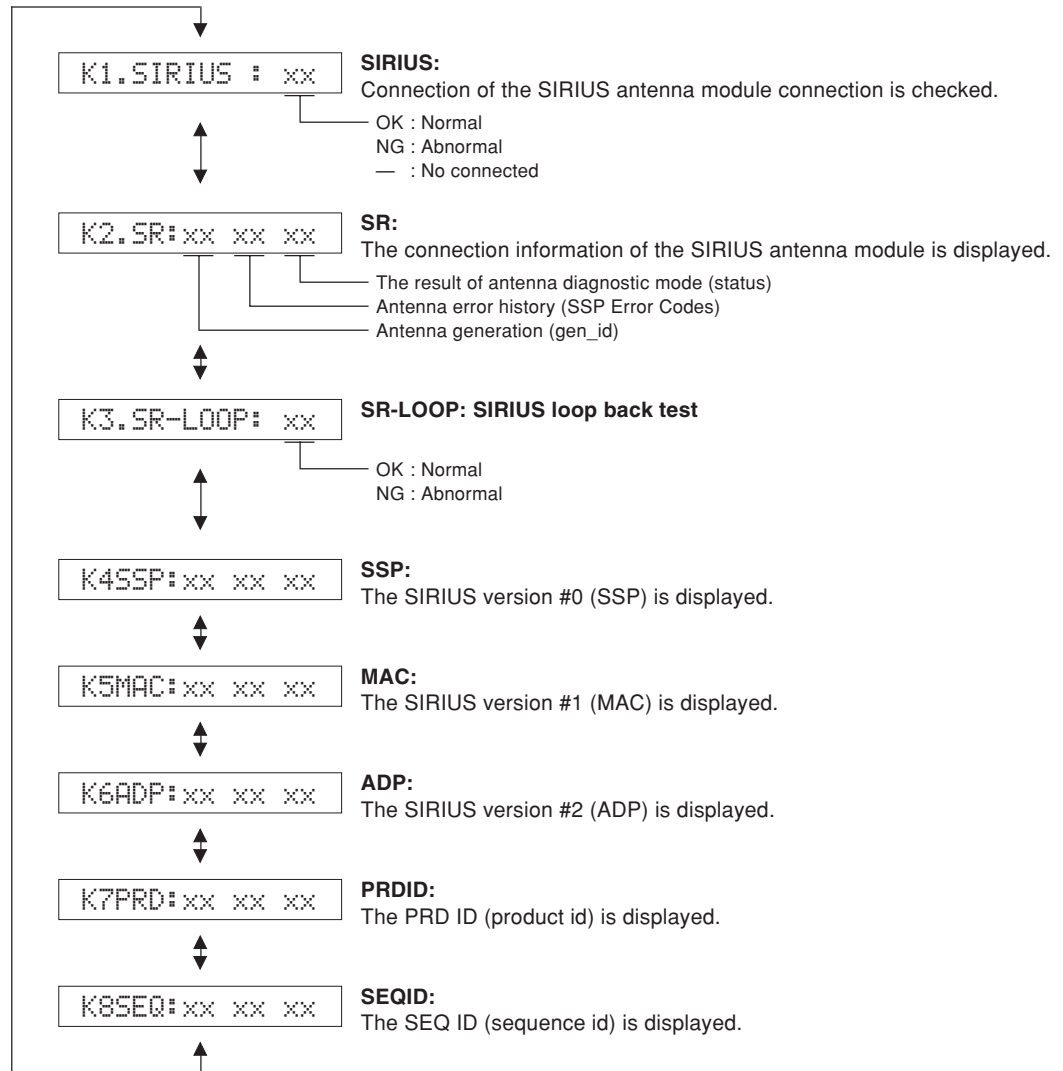

RX-V563/HTR-6150/  
DSP-AX563

**L. VIDEO CONVERSION**

The video circuit is checked by the sub-menu operation.

**Video INFO.**

The information of video signal is displayed.

L1. V-IN:

**CONVERSION S-Video**

The signal passage as shown below is checked.

L2. V-CONV S-V

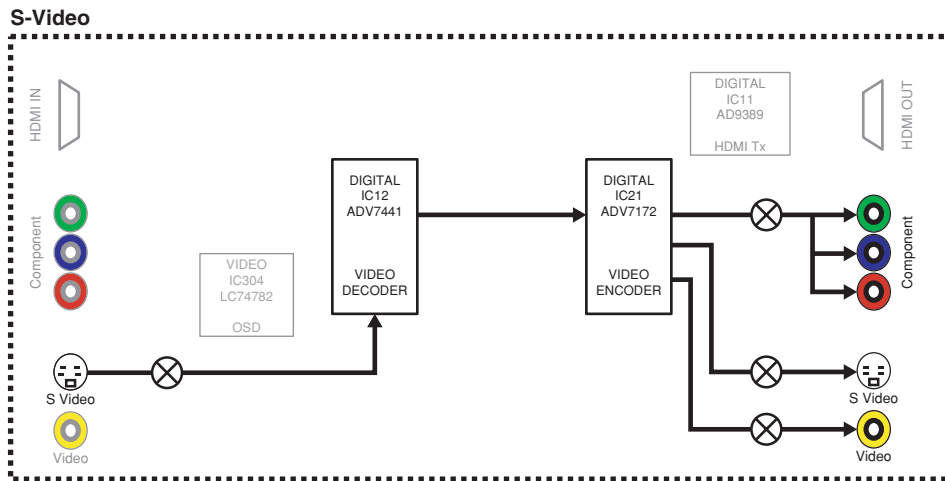

**CONVERSION CVBS**

The signal passage as shown below is checked.

L3. V-CONV CVBS

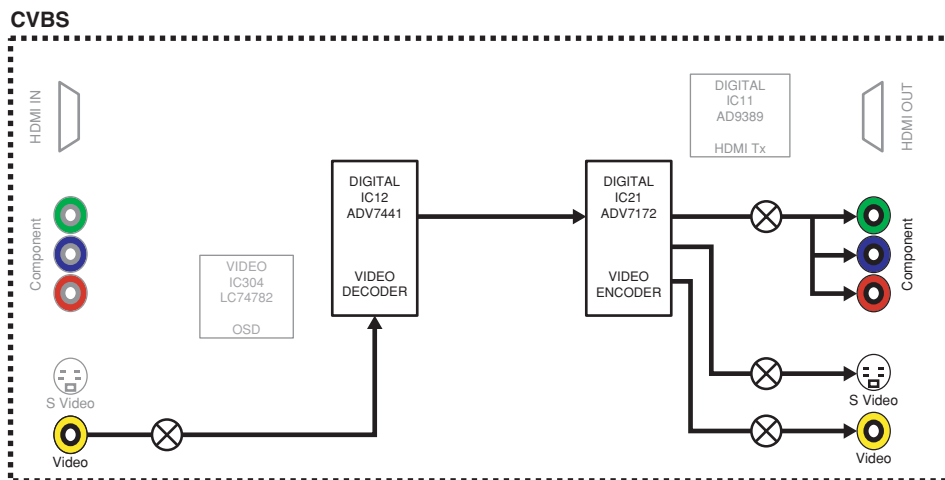

RX-V563/HTR-6150/  
DSP-AX563

**CONVERSION OFF**

The signal passage as shown below is checked.

L4.V-CONV OFF

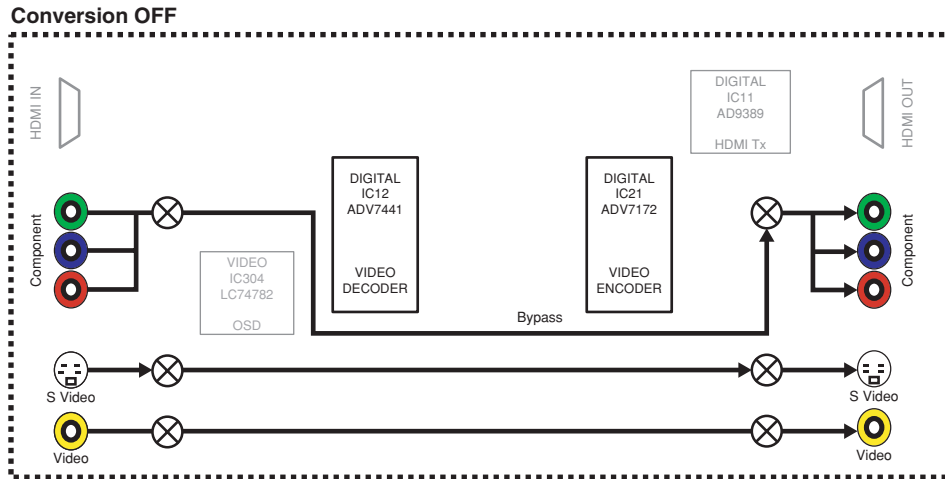

**Test pattern**

The test pattern is output from IC84 (DIGITAL P.C.B.).

L5.V-TestPttm

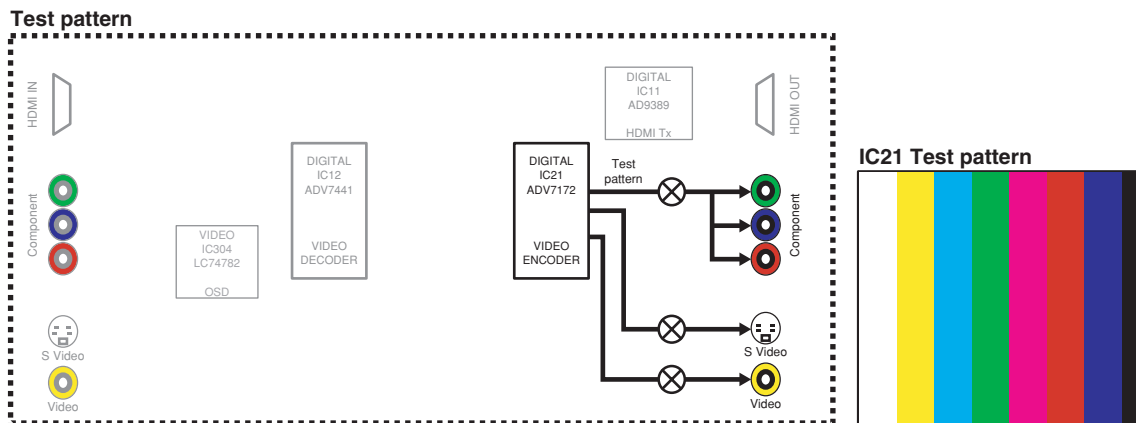

RX-V563/HTR-6150/  
DSP-AX563

**M. HDMI SELECT**

The audio signals input to HDMI IN are selected by the sub-menu and output.

**HDMI SPDIF (SPDIF audio playback)**

SPDIF signal is output.

M1.HDMI SPDIF

**HDMI NONE**

No signal is output.

M2.HDMI NONE

**HDMI IN1**

HDMI "IN 1" is output.

M3.HDMI IN1

**HDMI IN2**

HDMI "IN 2" is output.

M4.HDMI IN2

**I2C : xx xxx (I2C access check)**

M5.I2C:NG NY Y

All Y = "OK"  
Others = "NG"

Check item	Result	Display
HDMI Rx	OK	Y
(IC12 DSP P.C.B.)	NG	N
HDMI Tx	OK	Y
(IC11 DSP P.C.B.)	NG	N
VIDEO ENCODER	OK	Y
(IC21 DSP P.C.B.)	NG	N

**Model ID for EDID setting (U, C, F models)**

After replacement of DSP P.C.B or writing of the firmware, make sure to change the "M6 Model ID" setting to the same model name as this unit (RX-V563 or HTR-6150).

Press "PRESET/TUNING<" or "PRESET TUNING>" key for selection.

M6.RX-U563 ↔ M6.HTR-6150

R, T, K, A, G, E, L models

M6.RX-U563

B model

M6.DSP-AX563

RX-V563/HTR-6150/  
DSP-AX563

**N. A/D DATA CHECK**

This menu is used to display the A/D conversion value of the microprocessor which detects panel keys of the main unit and protection functions in using the sub-menu.

When K0/K1 menu is selected, keys become non-operable due to detection of the values of all keys. However, it is possible to advance to the next sub-menu by turning the VOLUME of the main unit. When using this function, note that turning the VOLUME more than 1 click would cause the volume value to change.

During signal processing, the condition before execution is maintained.

\* The figures in the diagram are given as reference only.

**PD/DI**

**PD:** PRD (Power amplifier DC protection detection)

The output of power amplifier DC (DC voltage) is detected.

Normal value: 27 to 70 (Reference voltage: 3.3 V=255)

\* If PRD is out of the normal value range, the protection function works to turn off the power.

**DI:** DOCK ID (DOCK ID detection)

(Reference voltage: 3.3 V=255)

DOCK detection for AD port (IC82 AD converter pin no. 4)

Pull-up resistance 10 k-ohms

DOCK type	DOCK (Bluetooth)	Reserved	Reserved	DOCK (iPod)	Reserved	(Development)	No connect
Ohm	0.56k	2.7k	5.6k	10.0k	18.0k	39.0k	—
DKID (Pin no. 21)	5-25	50-60	85-100	120-140	150-170	195-210	245-255

N1PD: 45DI: 0

**V1/V2**

**V1:** PRV1 (Voltage protection detection)

Voltage detects: ACL, 10V, VP, +6.3H and +3.3H

Normal value: 68 to 161 (Reference voltage: 3.3 V=255)

**V2:** PRV1 (Voltage protection detection)

Voltage detects: AC2, +12, -12, +5D, +5I, +5V and -5V

Normal value: 104 to 181 (Reference voltage: 3.3 V=255)

\* If PRD and PRV are out of the normal value range, the protection function works to turn off the power.

N2V1: 94V2:128

**TH/PL**

**TH:** THM (Thermo protection detection)  
 The temperature of the heat sink is detected.  
 Normal value: 0 to 136 (Reference voltage: 3.3 V=255)

\* If THM is out of the normal value range, the protection function works to turn off the power.

**PL:** PLDET (Power limiter detection)  
 The output voltage of power amplifier is detected.

```
N3TH: 64PL:255
```

U, C models (Reference voltage: 3.3 V=255)

	During normal operation	Value for starting limiter operation	Value for canceling limiter operation
PLDET	255	77	108
LIM H: 255 / L: 102	H	L	H

(LIM: Limiter control)

R, T, K, A, B, G, E, F, L models (Reference voltage: 3.3V=255)

	During normal operation	Value for starting limiter operation	Value for canceling limiter operation
PLDET	255	108	139
LIM H: 255 / L: 90	H	L	H

(LIM: Limiter control)

**PI/DE**

**PI:** PRI (Current protection detection)  
 The current of the power amplifier is detected.  
 Normal value: 0 to 100 (Reference voltage: 3.3 V=255)

**DE:** PDET (Sub-trans power detection)  
 Normal value: 0 to 255 (Reference voltage: 3.3 V=255)

\* If PRI and PDET are out of the normal value range, the protection function works to turn off the power.

```
N4PI: 0DE: 0
```



**K0/K1****K0/K1:** KEY0/KEY1 (Panel key of main unit)A/D value of the key fails to function properly when the standard value is deviated by  $\pm 4$ .

In this case, check the constant of partial pressure resistor, solder condition, etc. Refer to table.

(Reference voltage: 3.3 V=255)

N5K0:254K1:254

U, C, R, T, K, A, G, E, F, L models

Displayed	K0	K1
0 + 4	–	–
23 ± 4	SPEAKERS A/B/OFF	–
42 ± 4	TONE CONTROL	AUDIO SELECT
66 ± 4	PROGRAM <	INPUT >
92 ± 4	PROGRAM >	INPUT <
112 ± 4	STRAIGHT EFFECT	DIRECT
134 ± 4	A/B/C/D/E	PRESET/TUNING <
156 ± 4	BAND	PRESET/TUNING >
176 ± 4	ZONE2 ON/OFF	MEMORY
195 ± 4	EDIT PRESET/TUNING	INFO TUNING AUTO/MAN'L
215 ± 4	SYSTEM OFF	ZONE CONTROL

B model

Displayed	K0	K1
0 + 4	–	–
23 ± 4	SPEAKERS A/B/OFF	–
42 ± 4	TONE CONTROL	AUDIO SELECT
66 ± 4	PROGRAM <	INPUT >
92 ± 4	PROGRAM >	INPUT <
112 ± 4	STRAIGHT EFFECT	DIRECT
134 ± 4	–	–
156 ± 4	–	–
176 ± 4	–	–
195 ± 4	–	–
215 ± 4	–	–

**O. PROTECTION**

The A/D setting value of each protection is displayed.  
 (Reference voltage: 3.3 V=255)

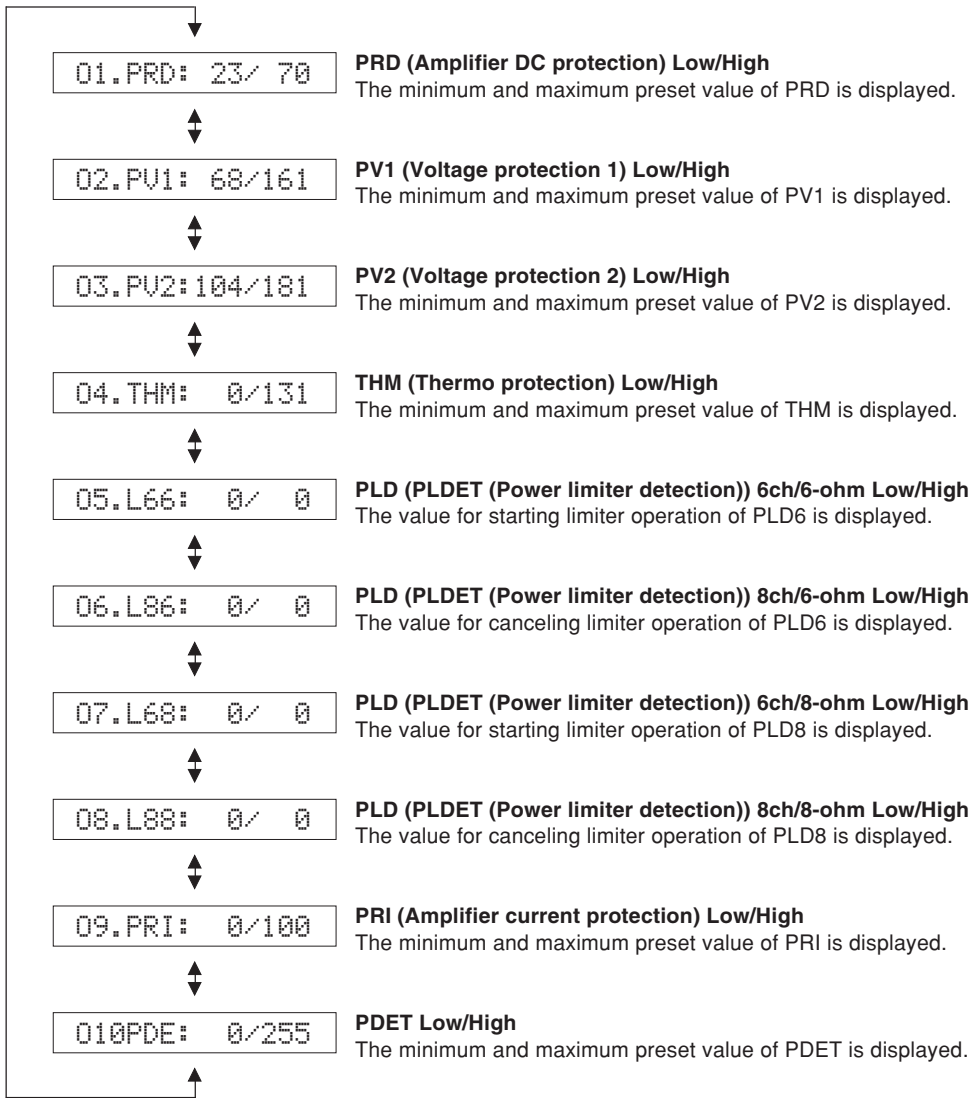

RX-V563/HTR-6150/DSP-AX563

**P. PROTECTION HISTORY**

Four protection histories are displayed.

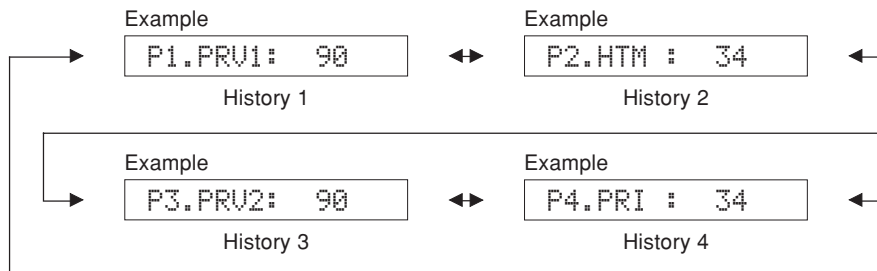

**Q. RESERVED**

**R. FACTORY PRESET**

This menu is used to reserve/inhibit initialization of the user memory (Parameters and set menu contents, etc. of the sound field program).

The signals are processed using EFFECT OFF (The L/R signal is output using ANALOG BYPASS).

R1.PRESET INHI	<b>PRESET INHIBIT (Initialization inhibited)</b> User memory initialization is not executed. Select this sub-menu to protect the user memory.
↕	
R2.PRESET RSRV	<b>PRESET RESERVED (Initialization reserved)</b> Initialization of the use memory is reserved. (Actually, initialization is executed the next time that the power is turned on.) Select this sub-menu to reset to the original factory settings or to reset the use memory. Any protection history will be cleared.

**CAUTION:** Before setting to the PRESET RESERVED, write down the existing preset memory content of the tuner in a table as shown below.

(This is because setting to the PRESET RESERVED will cause the user memory content of the tuner to be erased.)

Preset Group	P1	P2	P3	P4	P5	P6	P7	P8
A								
B								
C								
D								
E								

**S. ROM VER/SUM**

The version and checksum are displayed. The signal is processed using EFFECT OFF.

The checksum is obtained by adding the data at every 8-bit for each program area and expressing the result as a 4-figure hexadecimal data.

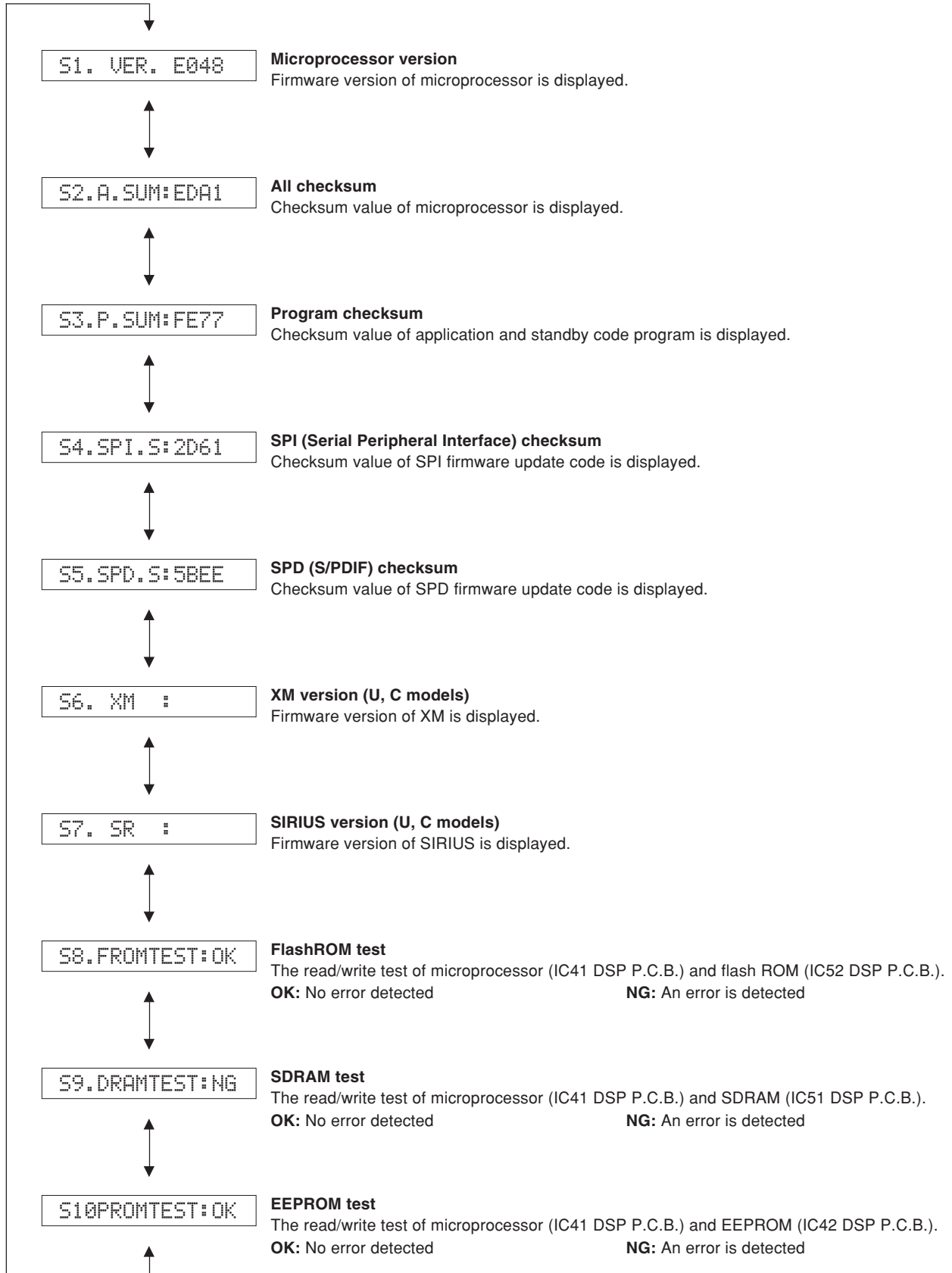

RX-V563/HTR-6150/DSP-AX563

## ■ DISPLAY DATA

### ● V6001: 17-BT-32GNK (OPERATION P.C.B.)

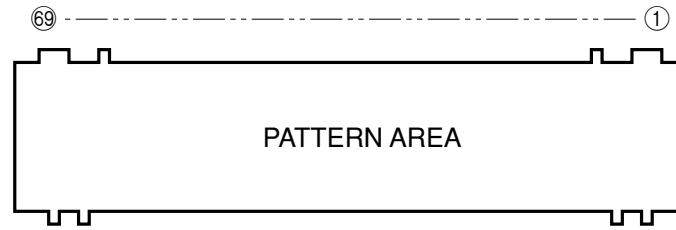

### ● PIN CONNECTION

Pin No.	69	68	67	66	65	64	63	62	61	60	59	58	57	56	55	54	53	52	51	50	49	48	47	46	45	44	43	42	41	40	39	38	37	36	35
Connection	F2	NX	NP	NP	P1	P2	P3	P4	P5	P6	P7	P8	P9	P10	P11	P12	P13	P14	P15	P16	P17	P18	P19	P20	P21	P22	P23	P24	P25	P26	P27	P28	P29	P30	P31

Pin No.	34	33	32	31	30	29	28	27	26	25	24	23	22	21	20	19	18	17	16	15	14	13	12	11	10	9	8	7	6	5	4	3	2	1
Connection	P32	P33	P34	P35	P36	P37	NX	NX	NX	NX	NX	NX	NX	17G	16G	15G	14G	13G	12G	11G	10G	9G	8G	7G	6G	5G	4G	3G	2G	1G	NP	NP	NX	F1

Note : 1) F1, F2 ..... Filament pin 2) NP ..... No pin 3) NX ..... No extend pin 4) 1G~17G ..... Grid pin

### ● GRID ASSIGNMENT

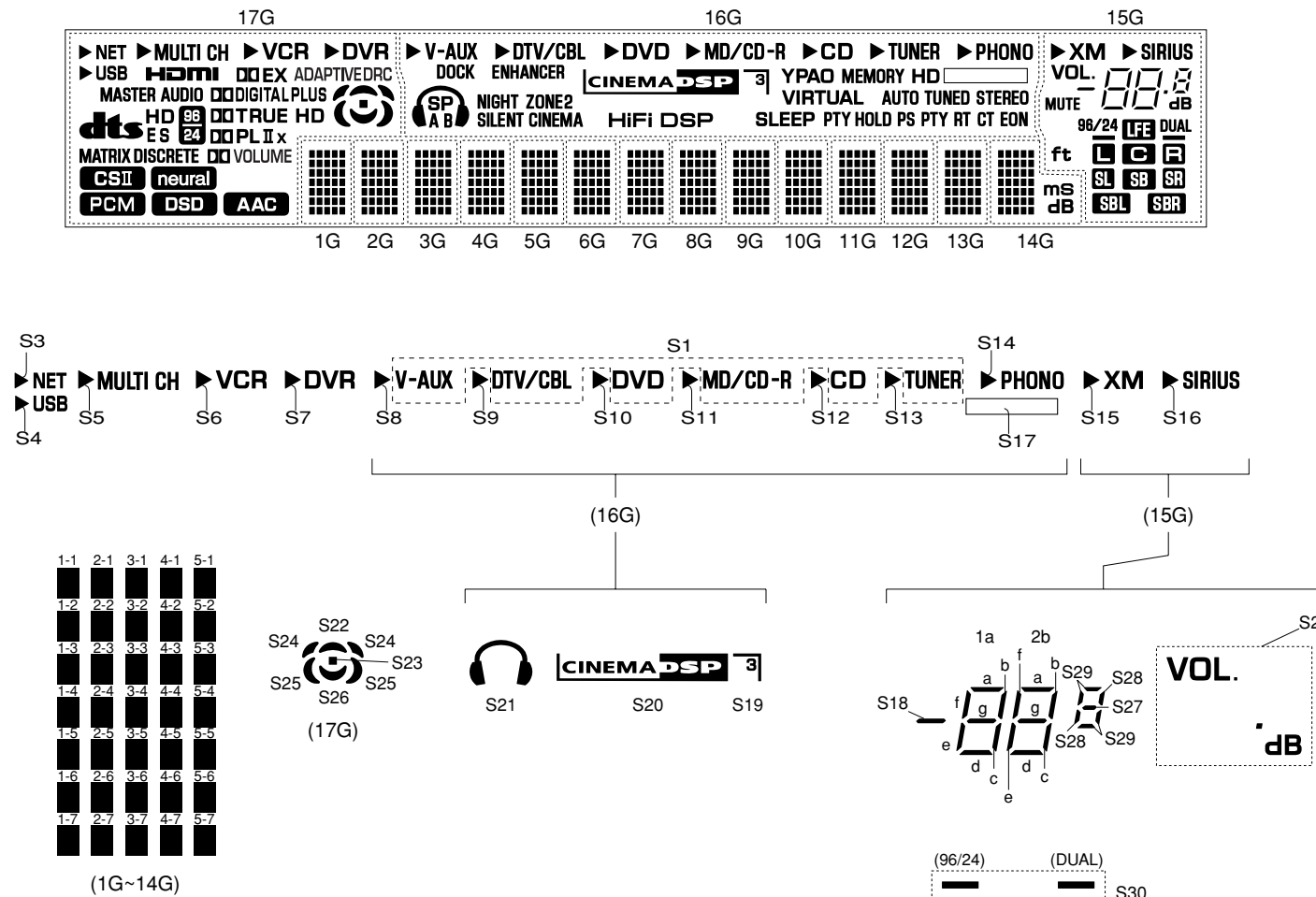

### ● ANODE CONNECTION

	17G	16G	15G	14G	13G~1G
1P	NET	S1	XM	1-1	1-1
2P	MULTI CH	PHONO	SIRIUS	2-1	2-1
3P	VCR	S8	S15	3-1	3-1
4P	DVR	S9	S16	4-1	4-1
5P	USB	S10	S2	5-1	5-1
6P	S3	S11	S18	1-2	1-2
7P	S5	S12	1a	2-2	2-2
8P	S6	S13	1b	3-2	3-2
9P	S7	S14	1c	4-2	4-2
10P	S4	DOCK	1d	5-2	5-2
11P	HDMI	ENHANCER	1e	1-3	1-3
12P	DOEX	S21	1f	2-3	2-3
13P	ADAPTIVEDRC	SP	1g	3-3	3-3
14P	MASTER AUDIO	A	2a	4-3	4-3
15P	dts	B	2b	5-3	5-3
16P	HD (ES)	NIGHT	2c	1-4	1-4
17P	ES	ZONE2	2d	2-4	2-4
18P	96/24	SILENT CINEMA	2e	3-4	3-4
19P	DODIGITAL	S20	2f	4-4	4-4
20P	PLUS	S19	2g	5-4	5-4
21P	DOTRUE HD	HIFI DSP	S27	1-5	1-5
22P	DOPL	YPAO	S28	2-5	2-5
23P	II	MEMORY	S29	3-5	3-5
24P	x	HD	MUTE	4-5	4-5
25P	MATRIX	S17	96/24	5-5	5-5
26P	DISCRETE	VIRTUAL	DUAL	1-6	1-6
27P	DO VOLUME	AUTO	ft	2-6	2-6
28P	CSII	TUNED	S30	3-6	3-6
29P	neural	STEREO	LFE	4-6	4-6
30P	PCM	SLEEP	L	5-6	5-6
31P	DSD	PTY (HOLD)	C	1-7	1-7
32P	AAC	HOLD	R	2-7	2-7
33P	S22	PS	SL	3-7	3-7
34P	S23	PTY (RT)	SB	4-7	4-7
35P	S24	RT	SR	5-7	5-7
36P	S25	CT	SBL	ms	-
37P	S26	EON	SBR	dB	-

## IC DATA

**IC31:** LC89057W-VF4AD-E (DSP P.C.B.)  
Digital audio interface transceiver

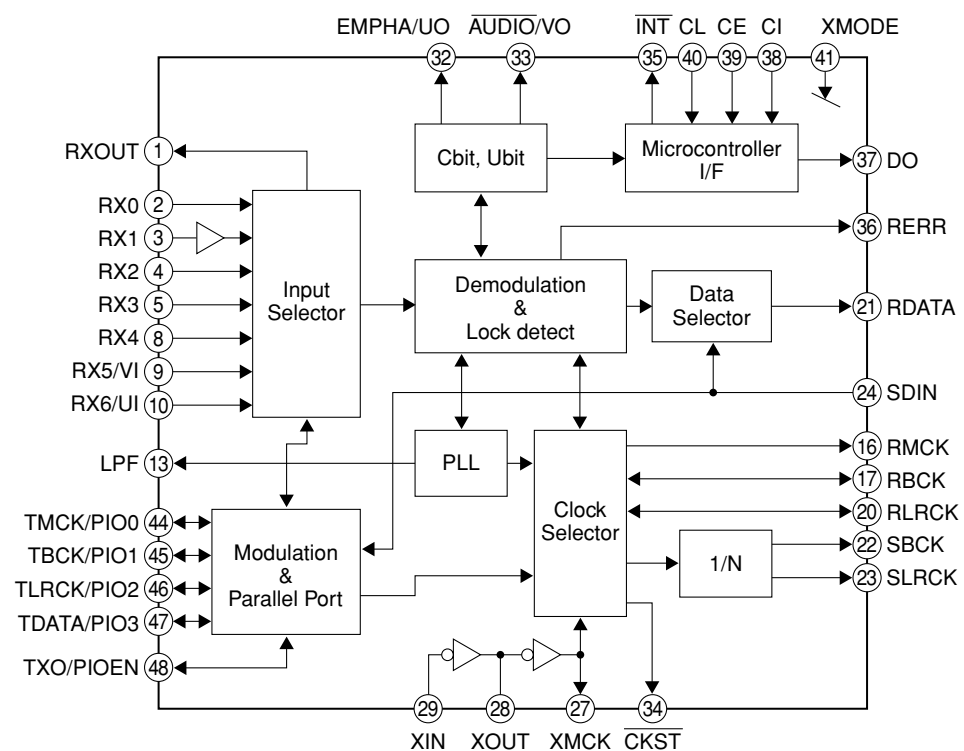

Pin No.	Function Name	I/O	Detail of Function
1	RXOUT	O	Output pin of input bi-phase selection data
2	RX0	Is	Input pin of TTL-compatible digital data
3	RX1	I	Digital data input pin with built-in amplifier that supports coaxial
4	RX2	Is	Input pin of TTL-compatible digital data
5	RX3	Is	Input pin of TTL-compatible digital data
6	DGND		Digital GND
7	DVDD		Digital power supply (3.3 V)
8	RX4	Is	Input pin of TTL-compatible digital data
9	RX5	Is	TTL-compatible digital data / Validity flag input pin for modulation
10	RX6	Is	TTL-compatible digital data / User data input pin for modulation
11	DVDD		Digital power supply for PLL
12	DGND		Digital GND for PLL
13	LPF	O	PLL loop filter connection pin
14	AVDD		Analog power supply for PLL (3.3 V)
15	AGND		Analog GND for PLL
16	RMCK	O	R system clock output pin (256 fs, 512 fs, XIN, VCO)
17	RBCK	O/I	R bit clock input/output pin (64 fs)
18	DGND		Digital GND
19	DVDD		Digital power supply (3.3 V)
20	RLRCK	O/I	R LR clock input/output pin (fs)
21	RDATA	O	Output pin of serial audio data
22	SBCK	O	S bit clock output pin (32 fs, 64 fs, 128 fs) (No connected.)
23	SLRCK	O	S LR clock output pin (fs/2, fs, 2 fs) (No connected.)
24	SDIN	Is	Input pin of serial audio data
25	DGND		Digital GND
26	DVDD		Digital power supply (3.3 V)
27	XMCK	O	Oscillation amplifier output pin
28	XOUT	O	Quartz resonator connection output pin
29	XIN	I	Quartz resonator connection, input pin of external supply clock (24.576 MHz or 12.288 MHz)
30	DVDD		Digital power supply (3.3 V)
31	DGND		Digital GND
32	EMPHA/UO/CD	I/O	Emphasis information / U data output / C data output / Chip address setting pin
33	AUDIO/VO	I/O	Non-PCM detection / V flag output / Chip address setting pin
34	CKST/PT	I/O	Output of clock switch transitional period signal / Preamble B output / Demodulation master or slave function switch pin
35	INT	I/O	Interrupt output for microprocessor (Possible to select an interrupt factor.) / Modulation or general-purpose I/O switch pin
36	RERR	O	PLL clock error, data error flag output
37	DO	O	Microprocessor I/F, read data output pin (3-state)
38	DI	Is	Microprocessor I/F, write data input pin
39	CE	Is	Microprocessor I/F, chip enable input pin
40	CL	Is	Microprocessor I/F, clock input pin"
41	XMODE	Is	System reset input pin
42	DGND		Digital GND
43	DVDD		Digital power supply (3.3 V)
44	PIO0	O	Sport input select
45	PIO1	O	Sport input select
46	PIO2	O	Audio direct stereo ON
47	PIO3	O	Audio clock select
48	PIOEN	I/O	Modulation data output / General-purpose I/O enable output pin

- 1) Withstand voltage input/output: I or O = -0.3 to 3.6 V, Is = -0.3 to 5.5 V
- 2) Pins 32 and 33 are input pins for chip address setting, when pin 41 = "L".
- 3) Pin 34 is a demodulation function master or an input pin for slave setting, when pin 41 = "L".
- 4) Pin 35 is a modulation function or an input pin for general-purpose I/O function switch setting, when pin 41 = "L".
- 5) ON/OFF for all power supplies must be done at the same timing as a latch-up countermeasure.

IC41: AD91089SKBC CPU (DSP P.C.B.)  
Microprocessor

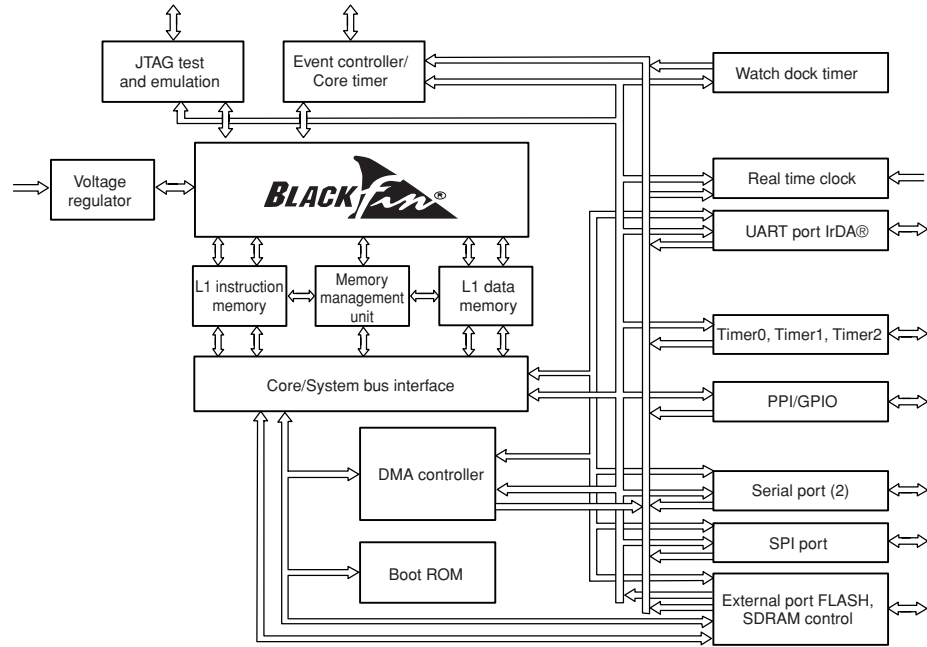

GND	1	176 - GND	132 - GND
GND	2	175 - GND	131 - GND
GND	3	174 - GND	130 - GND
VROUT	4	173 - SCKE	129 - GND
VROUT0	5	172 - SMS	128 - GND
VDDEXT	6	171 - VDDEXT	127 - ADDR13
GND	7	170 - GND	126 - ADDR14
GND	8	169 - CLKOUT	125 - ADDR15
GND	9	168 - VDDINT	124 - ADDR16
CLKIN	10	167 - SRAS	123 - ADDR17
XTAL	11	166 - SCAS	122 - ADDR18
VDDEXT	12	165 - SWE	121 - ADDR19
RESET	13	164 - SA10	120 - BGH
NMI	14	163 - BR	119 - BG
GND	15	162 - ARDY	118 - VDDEXT
RTX0	16	161 - AMISO	117 - GND
RTXI	17	160 - AMS1	116 - DATA0
VDDRTC	18	159 - AMS2	115 - DATA1
GND	19	158 - AMS3	114 - DATA2
VDDEXT	20	157 - VDDINT	113 - DATA3
PPI_CLK	21	156 - VDDEXT	112 - DATA4
PPI0	22	155 - GND	111 - VDDINT
PPI1	23	154 - AOE	110 - DATA5
PPI2	24	153 - ARE	109 - DATA6
VDDINT	25	152 - AVE	108 - DATA7
PPI3	26	151 - ABEO	107 - VDDEXT
PF15	27	150 - ABE1	106 - GND
PF14	28	149 - ADDR1	105 - DATA8
PF13	29	148 - ADDR2	104 - DATA9
GND	30	147 - ADDR3	103 - DATA10
VDDEXT	31	146 - ADDR4	102 - DATA11
PF12	32	145 - VDDEXT	101 - DATA12
PF11	33	144 - GND	100 - DATA13
PF10	34	143 - VDDINT	99 - DATA14
PF9	35	142 - ADDR5	98 - DATA15
PF8	36	141 - ADDR6	97 - GND
PF7	37	140 - ADDR7	96 - BMODE0
PF6	38	139 - ADDR8	95 - BMODE1
GND	39	138 - ADDR9	94 - TCK
GND	40	137 - ADDR10	93 - VDDEXT
GND	41	136 - ADDR11	92 - GND
GND	42	135 - ADDR12	91 - GND
GND	43	134 - VDDEXT	90 - GND
GND	44	133 - GND	89 - GND
VDDEXT	45		
PF5	46		
PF4	47		
PF3	48		
PF2	49		
PF1	50		
PF0	51		
VDDINT	52		
SCK	53		
MISO	54		
MOSI	55		
GND	56		
VDDEXT	57		
DT1SEC	58		
DT1PRI	59		
TFS1	60		
TSClk1	61		
DR1SEC	62		
DR1PRI	63		
RFS1	64		
RSCLK1	65		
VDDINT	66		
DT0SEC	67		
DT0PRI	68		
TFS0	69		
GND	70		
VDDEXT	71		
TSCKL0	72		
DR0SEC	73		
DR0PRI	74		
RFS0	75		
RSCLK0	76		
TMR2	77		
TMR1	78		
TMR0	79		
VDDINT	80		
TX	81		
RX	82		
EMU	83		
TRST	84		
TMS	85		
TDI	86		
TDO	87		
GND	88		

RX-V563/HTR-6150/  
DSP-AX563

**Memory Interface**

Pin No.	Function Name	I/O	Detail of Function
121	ADDR19	O	Address bus for async/Sync access
122	ADDR18		
123	ADDR17		
124	ADDR16		
125	ADDR15		
126	ADDR14		
127	ADDR13		
135	ADDR12	O	Address bus for async/Sync access
136	ADDR11		
137	ADDR10		
138	ADDR9		
139	ADDR8		
140	ADDR7		
141	ADDR6		
142	ADDR5	O	Address bus for async/Sync access
146	ADDR4		
147	ADDR3		
148	ADDR2		
149	ADDR1		
98	DATA15	I/O	Daea bus for async access
99	DATA14		
100	DATA13		
101	DATA12		
102	DATA11		
103	DATA10		
104	DATA9		
105	DATA8		
108	DATA7	I/O	Daea bus for async access
109	DATA6		
110	DATA5		
112	DATA4	I/O	Daea bus for async access
113	DATA3		
114	DATA2		
115	DATA1		
116	DATA0	O	Byte enables/Data masks for async/Sync access
150	ABE1		
151	ABE0	I	Bus request (This pin should be pulled HIGH if not used.)
163	BR		
119	BG	O	Bus grant
120	BGH	O	Bus grant hang

**Asynchronous memory control**

Pin No.	Function Name	I/O	Detail of Function
158	AMS3	O	Banks select
159	AMS2		
160	AMS1		
161	AMS0		
162	ARDY	I	hardware ready control (This pin should be pulled HIGH if not used.)
154	AOE	O	Output enable
153	ARE	O	Read enable
152	AWE	O	Write enable

**Synchronous memory control**

Pin No.	Function Name	I/O	Detail of Function
167	SRAS	O	Row address strobe
166	SCAS	O	Column address strobe
165	SWE	O	Write enable
173	SCKE	O	Clock enable
169	CLKOUT	O	Clock output
164	SA10	O	A10 pin
172	SMS	O	Bank select

**Timers**

Pin No.	Function Name	I/O	Detail of Function
79	TMR0	I/O	Timer0
78	TMR1	I/O	Timer1/PPI frame sync1
77	TMR2	I/O	Timer2/PPI frame sync2

**PPI port**

Pin No.	Function Name	I/O	Detail of Function
22	PPI0	I/O	PPI3-0
23	PPI1		
24	PPI2		
26	PPI3		
21	PPI_CLK	I	PPI clock/External timer reference

**Port F:**

**GPIO/Parallel peripheral interface port/SPI/Timers**

Pin No.	Function Name	I/O	Detail of Function
51	PF0	I/O	GPIO/SPI slave select input
50	PF1	I/O	GPIO/SPI slave select enable 1/ Timer alternate clock input
49	PF2	I/O	GPIO/SPI slave select enable 2
48	PF3	I/O	GPIO/SPI slave select enable 3/ PPI frame sync 3
47	PF4	I/O	GPIO/SPI slave select enable 4/ PPI 15
46	PF5	I/O	GPIO/SPI slave select enable 5/ PPI 14
38	PF6	I/O	GPIO/SPI slave select enable 6/ PPI 13
37	PF7	I/O	GPIO/SPI slave select enable 7/ PPI 12
36	PF8	I/O	GPIO/PPI 11
35	PF9	I/O	GPIO/PPI 10
34	PF10	I/O	GPIO/PPI 9
33	PF11	I/O	GPIO/PPI 8
32	PF12	I/O	GPIO/PPI 7
29	PF13	I/O	GPIO/PPI 6
28	PF14	I/O	GPIO/PPI 5
27	PF15	I/O	GPIO/PPI 4

RX-V563/HTR-6150/DSP-AX563



**JTAG port**

Pin No.	Function Name	I/O	Detail of Function
94	TCK	I	JTAG clock
87	TDO	O	JTAG serial data out
86	TDI	I	JTAG serial data in
85	TMS	I	JTAG mode select
84	TRST	I	JTAG reset (This pin is should be pulled LOW if JTAG is not used.)
83	EMU	O	Emulation output

**SPI port**

Pin No.	Function Name	I/O	Detail of Function
55	MOSI	I/O	Master out slave in
54	MISO	I/O	Master in slave out (This pin is should be pulled HIGH through a 4.7 k-ohms resistor if booting via the SPI port.)
53	SCK	I/O	SPI clock

**Serial ports**

Pin No.	Function Name	I/O	Detail of Function
76	RSCLK0	I/O	SPORT0 receive serial clock
75	RFS0	I/O	SPORT0 receive frame sync
74	DR0PRI	I	SPORT0 receive data primary
73	DR0SEC	I	SPORT0 receive data secondary
72	TSCLK0	I/O	SPORT0 transmit serial clock
69	TFS0	I/O	SPORT0 transmit frame sync
68	DTOPRI	O	SPORT0 transmit data primary
67	DTOSEC	O	SPORT0 transmit data secondary
65	RSCLK1	I/O	SPORT1 receive serial clock
64	RFS1	I/O	SPORT1 receive frame sync
63	DR1PRI	I	SPORT1 receive data primary
62	DR1SEC	I	SPORT1 receive data secondary
61	TSCLK1	I/O	SPORT1 transmit serial clock
60	TFS1	I/O	SPORT1 transmit frame sync
59	DT1PRI	O	SPORT1 transmit data primary
58	DT1SEC	O	SPORT1 transmit data secondary

**UART port**

Pin No.	Function Name	I/O	Detail of Function
82	RX	I	UART receive
81	TX	O	UART transmit

**Real-time clock**

Pin No.	Function Name	I/O	Detail of Function
17	RTXI	I	RTC crystal input (This pin should be pulled LOW when not used.)
16	RTXO	O	RTC crystal output

**Clock**

Pin No.	Function Name	I/O	Detail of Function
10	CLKIN	I	Clock/Crystal input (This pin needs to be at a level or clocking.)
11	XTAL	O	Crystal output

**Mode controls**

Pin No.	Function Name	I/O	Detail of Function
13	RESET	I	Reset (This pin is always active during core power-on.)
14	NMI	I	Nonmaskable interrupt (This pin should be pulled LOW when not used.)
95	BMODE1	I	Boot mode strap (These pins must be pulled to the state required for the desired boot mode.)
96	BMODE0		

**Voltage regulator**

Pin No.	Function Name	I/O	Detail of Function
4	VROUT1	O	External FET drive
5	VROUT0		

**Supplies**

Pin No.	Function Name	I/O	Detail of Function
6	VDDEXT	P	I/O power supply
12			
20			
31			
45			
57			
71			
93			
107			
118			
134			
145			
156			
171			
25	VDDINT	P	Core power supply
52			
66			
80			
111			
143			
157			
168	VDDRTC	P	Real-time clock power supply
18			

Pin No.	Function Name	I/O	Detail of Function
1	GND	G	External ground
2			
3			
7			
8			
9			
15			
19			
30			
39			
40			
41			
42			
43			
44			
56			
70			
88			
89			
90			
91			
92			
97			
106			
117			
128			
133			
144			
155			
170			
171			
172			
173			
174			
175			
176			

RX-V563/HTR-6150/  
DSP-AX563

• **Microprocessor extended port**

**IC57-IC59:** SN74LV574PWR (DSP P.C.B.)  
Octal edge-triggered D-type flip-flops with 3-state outputs

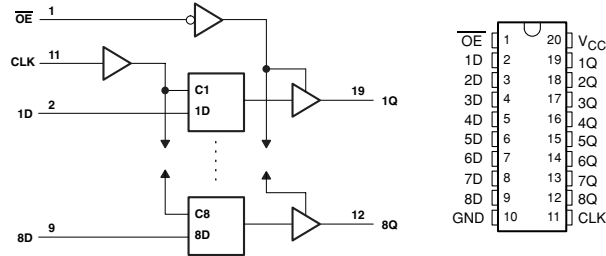

**IC57**

Pin No.	Port Name	Function Name	Detail of Function
1	/OE	/EXPE	Extended port enable
2	1D	D00	Data bus 00
3	2D	D01	Data bus 01
4	3D	D02	Data bus 02
5	4D	D03	Data bus 03
6	5D	D04	Data bus 04
7	6D	D05	Data bus 05
8	7D	D06	Data bus 06
9	8D	D07	Data bus 07
10	GND	DGND	Ground of external
11	LCK	NPGA_EXSTB	Bank select 1
12	8Q	-	-
13	7Q	R2A_CLK	E-Vol control clock
14	6Q	R2A_DATA	E-Vol control data
15	5Q	VIDEO_MTVR1	DVR REC output inhibit
16	4Q	/DAC_CS	DA converter chip select
17	3Q	/ADC_CS	AD converter chip select
18	2Q	/VFD_CS	VFD (Front display) chip select
19	1Q	/DIR_CS	Audio CODEC chip select
20	VCC	VCC	Power supply +3.3V

**IC58**

Pin No.	Port Name	Function Name	Detail of Function
1	/OE	/EXPE	Extended port enable
2	1D	D00	Data bus 00
3	2D	D01	Data bus 01
4	3D	D02	Data bus 02
5	4D	D03	Data bus 03
6	5D	D04	Data bus 04
7	6D	D05	Data bus 05
8	7D	D06	Data bus 06
9	8D	D07	Data bus 07
10	GND	DGND	Ground of external
11	CLK	NPGA_EXSTB	Bank select 1
12	8Q	PRY	Power relay control
13	7Q	XM_POWER	XM power enable
14	6Q	/Z2MT	Zone2 L/R mute
15	5Q	/SBMT	Surround back L/R mute
16	4Q	/SWMT	Subwoofer mute
17	3Q	/CMT	Center mute
18	2Q	/SMT	Surround L/R mute
19	1Q	/FMT	Front L/R mute
20	VCC	VCC	Power supply +3.3V

RX-V563/HTR-6150/  
DSP-AX563

**IC59**

Pin No.	Port Name	Function Name	Detail of Function
1	/OE	/EXPE	Extended port enable
2	1D	D00	Data bus 00
3	2D	D01	Data bus 01
4	3D	D02	Data bus 02
5	4D	D03	Data bus 03
6	5D	D04	Data bus 04
7	6D	D05	Data bus 05
8	7D	D06	Data bus 06
9	8D	D07	Data bus 07
10	GND	DGND	Ground of external
11	CLK	NPGA_EXSTB	Bank select 0
12	8Q	ADC_SELECT_C	Selector C
13	7Q	ADC_SELECT_B	Selector B
14	6Q	ADC_SELECT_A	Selector A
15	5Q	SBRY	Speaker relay SB
16	4Q	HPRY	Headphone relay
17	3Q	CSRY	Speaker relay C/SW
18	2Q	MRYB	Speaker relay F/B
19	1Q	MRYA	Speaker relay F/A
20	VCC	VCC	Power supply +3.3V

**IC56:** SN74AHCT574AWR (DSP P.C.B.)  
Octal edge-triggered D-type flip-flops with 3-state outputs

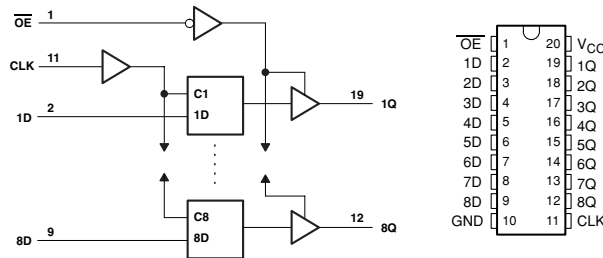

Pin No.	Port Name	Function Name	Detail of Function
1	/OE	/EXPE	Extended port enable
2	1D	D00	Data bus 00
3	2D	D01	Data bus 01
4	3D	D02	Data bus 02
5	4D	D03	Data bus 03
6	5D	D04	Data bus 04
7	6D	D05	Data bus 05
8	7D	D06	Data bus 06
9	8D	D07	Data bus 07
10	GND	DGND	Ground of external
11	CLK	NPGA_EXSTB	Bank select 0
12	8Q	5VIDEO_VIA	Video input selector A
13	7Q	5VIDEO_VIB	Video input selector B
14	6Q	5VIDEO_VIC	Video input selector C
15	5Q	/5VIDEO_MTMON	Monitor output inhibit
16	4Q	/5VIDEO_CMON	Component output inhibit
17	3Q	5VIDEO_CBYPASS	Component bypass
18	2Q	5VIDEO_CMP1	Component select 1
19	1Q	5VIDEO_CMP0	Component select 2
20	VCC	VCC	Power supply +5V

RX-V563/HTR-6150/DSP-AX563

• **Microprocessor ADC select port**

**IC81:** ADC084S021C1MM (DSP P.C.B.)  
4-channel, 200 kSPS, 8-bit A/D converter

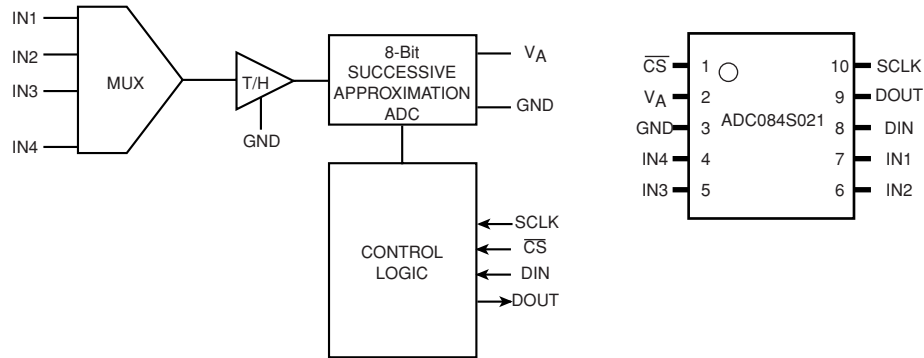

Pin No.	Port Name	Function Name	Detail of Function
1	/CS	/ADC_CS	CS for microprocessor
2	VA	+3.3S	Power supply +3.3V
3	GND	DGND	Ground of external
4	IN4	ADC_COM2	SPI bus COM (IC83)
5	IN3	ADC_COM1	SPI bus COM (IC82)
6	IN2	KEY1	Key input 1
7	IN1	KEY0	Key input 0
8	DIN	SPIMI	Master output/slave input
9	DOUT	SPIMO	Master input/slave output
10	SCLK	SPISCK	SPI clock

Key detection for A/D port  
Key input (A/D) pull-up resistance 10 k-ohms

U, C, R, T, K, A, G, E, F, L models

Ohm	0	+ 1.0 k	+ 1.0 k	+ 1.5 k	+ 2.2 k	+ 2.2 k	+ 3.3 k	+ 4.7 k	+ 6.8 k	+ 10.0 k	+ 22.0 k
V	0-0.2	0.2-0.4	0.4-0.7	0.7-1.0	1.0-1.3	1.3-1.6	1.6-1.9	1.9-2.1	2.1-2.4	2.4-2.7	2.7-3.0
KEY INPUT 0 (7 pin)	-	SPEAKERS A/B/OFF	TONE CONTROL	PROGRAM <	PROGRAM >	STRAIGHT EFFECT	A/B/C/D/E	BAND	ZONE2 ON/OFF	EDIT PRESET/TUNING	SYSTEM OFF
KEY INPUT 1 (6 pin)	-	-	AUDIO SELECT	INPUT >	INPUT <	DIRECT	PRESET/TUNING <	PRESET/TUNING >	MEMORY	INFO TUNING AUTO/MAN'L	ZONE CONTROL

B model

Ohm	0	+ 1.0 k	+ 1.0 k	+ 1.5 k	+ 2.2 k	+ 2.2 k	+ 3.3 k	+ 4.7 k	+ 6.8 k	+ 10.0 k	+ 22.0 k
V	0-0.2	0.2-0.4	0.4-0.7	0.7-1.0	1.1-1.3	1.3-1.6	1.6-1.9	1.9-2.1	2.1-2.4	2.4-2.7	2.7-2.9
KEY INPUT 0 (7 pin)	-	SPEAKERS A/B/OFF	TONE CONTROL	PROGRAM <	PROGRAM >	STRAIGHT EFFECT	-	-	-	-	-
KEY INPUT 1 (6 pin)	-	-	AUDIO SELECT	INPUT >	INPUT <	DIRECT	-	-	-	-	-

RX-V563/HTR-6150/DSP-AX563

**IC82, IC83:** SN74LV4051APWR (DSP P.C.B.)  
8-channel analog multiplexers/demultiplexers

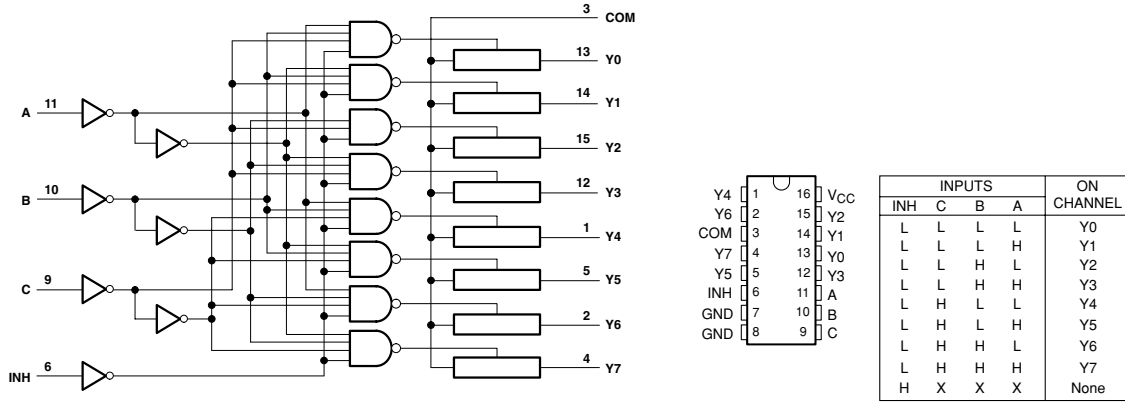

**IC82**

Pin No.	Port Name	Function Name	Detail of Function
1	Y4	/TUNER_TUNED	Tuner tuned detection
2	Y6	XM_ANT	XM antenna
3	COM	ADC_COM1	SPI bus COM (IC81)
4	Y7	DOCK_ID	DOCK detection (Normal DOCK or Bluetooth adapter)
5	Y5	IP_DET	iPod detection
6	INH	DGND	Ground of external
7	GND	DGND	Ground of external
8	GND	DGND	Ground of external
9	C	SELECT C	ADC selector C
10	B	SELECT B	ADC selector B
11	A	SELECT A	ADC selector A
12	Y3	THM	Temperature detection
13	Y0	DEST1	Destination detection
14	Y1	PRV1	Power supply protection 1
15	Y2	PRD	AMP DC protecton
16	Vcc	+3.3S	Power supply +3.3V

DOCK detection for AD port (IC82 AD converter pin no. 4)  
Pull-up resistance 10 k-ohms

DOCK connector	DOCK (Bluetooth)	Reserved	Reserved	DOCK (iPod)	Reserved	(Development)	No connect
Ohm	0.56k	2.7k	5.6k	10.0k	18.0k	39.0k	-
DKID (Pin no. 21)	5-25	50-60	85-100	120-140	150-170	195-210	245-255

**IC83**

Pin No.	Port Name	Function Name	Detail of Function
1	Y4	/TUNER_STEREO	Tuner stereo detection
2	Y6	XM_LINK	XM link
3	COM	ADC_COM2	SPI bus COM (IC81)
4	Y7	/HP_DET	Headphone detect
5	Y5	IP_AP	iPod
6	INH	DGND	Ground of external
7	GND	DGND	Ground of external
8	GND	DGND	Ground of external
9	C	SELECT C	ADC selector C
10	B	SELECT B	ADC selector B
11	A	SELECT A	ADC selector A
12	Y3	PRI	AMP curent protection
13	Y0	DEST2	-
14	Y1	PRV2	Power supply protection 2
15	Y2	PLDET	Output voltage of power amplifier detection
16	Vcc	+3.3S	Power supply +3.3V

RX-V563/HTR-6150/DSP-AX563

IC401 : R2A15218FP (MAIN P.C.B.)

8 ch electronic volume with 11 input selector and tone control

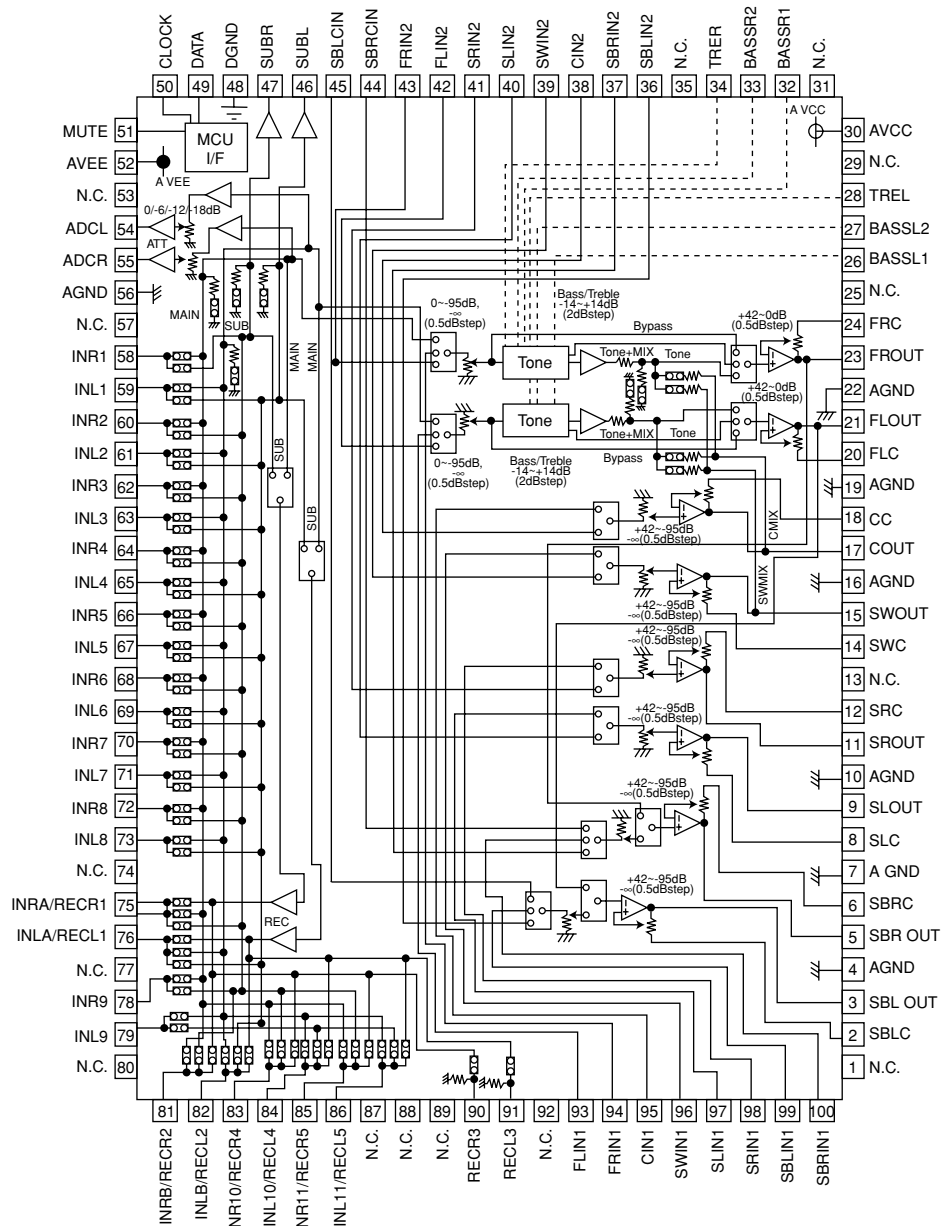

RX-V563/HTR-6150/  
DSP-AX563

Pin No.	Function Name	Detail of Function
1	NC	
2	SBLC	Connects capacitor for reducing click noise of L/R/C/SW/SL/SR/SBL/SBR channel volume
3	SBL OUT	Output pin of FL/FR/C/SW/SL/SR/SBL/SBR channel
4	AGND	Analog ground of internal circuit
5	SBR OUT	Output pin of FL/FR/C/SW/SL/SR/SBL/SBR channel
6	SBRC	Connects capacitor for reducing click noise of L/R/C/SW/SL/SR/SBL/SBR channel volume
7	AGND	Analog ground of internal circuit
8	SLC	Connects capacitor for reducing click noise of L/R/C/SW/SL/SR/SBL/SBR channel volume
9	SLOUT	Output pin of FL/FR/C/SW/SL/SR/SBL/SBR channel
10	AGND	Analog ground of internal circuit
11	SROUT	Output pin of FL/FR/C/SW/SL/SR/SBL/SBR channel
12	SRC	Connects capacitor for reducing click noise of L/R/C/SW/SL/SR/SBL/SBR channel volume
13	NC	
14	SWC	Connects capacitor for reducing click noise of L/R/C/SW/SL/SR/SBL/SBR channel volume
15	SWOUT	Output pin of FL/FR/C/SW/SL/SR/SBL/SBR channel
16	AGND	Analog ground of internal circuit
17	COUT	Output pin of FL/FR/C/SW/SL/SR/SBL/SBR channel
18	CC	Connects capacitor for reducing click noise of L/R/C/SW/SL/SR/SBL/SBR channel volume
19	AGND	Analog ground of internal circuit
20	FLC	Connects capacitor for reducing click noise of L/R/C/SW/SL/SR/SBL/SBR channel volume
21	FLOUT	Output pin of FL/FR/C/SW/SL/SR/SBL/SBR channel
22	AGND	Analog ground of internal circuit
23	FROUT	Output pin of FL/FR/C/SW/SL/SR/SBL/SBR channel
24	FRC	Connects capacitor for reducing click noise of L/R/C/SW/SL/SR/SBL/SBR channel volume
25	NC	
26	BASSL1	Frequency characteristic setting pin of L/R channel tone control (Bass)
27	BASSL2	
28	TREL	Frequency characteristic setting pin of L/R channel tone control (Treble)
29	NC	
30	AVCC	Positive power supply to internal circuit
31	NC	
32	BASSR1	Frequency characteristic setting pin of L/R channel tone control (Bass)
33	BASSR2	
34	TRER	Frequency characteristic setting pin of L/R channel tone control (Treble)
35	NC	
36	SBLIN2	Input pin of L/R/C/SW/SL/SR/SBL/SBR channel (Multi IN 1/2)
37	SBRIN2	
38	CIN2	
39	SWIN2	
40	SLIN2	
41	SRIN2	
42	FLIN2	
43	FRIN2	
44	SBRCIN	Input pin for SBL/SBR channel volume
45	SBLCIN	
46	SUBL	Output pin for L/R channel SUB output
47	SUBR	
48	DGND	Digital ground of internal circuit
49	DATA	Input pin of control data
50	CLOCK	Input pin of control clock



Pin No.	Function Name	Detail of Function
51	MUTE	Outside mute control pin
52	AVEE	Negative power supply to internal circuit
53	NC	
54	ADCL	Output pin for L/R channel ADC
55	ADCR	
56	AGND	Analog ground of internal circuit
57	NC	
58	INR1	Input pin of L/R channel (Input selector)
59	INL1	
60	INR2	
61	INL2	
62	INR3	
63	INL3	
64	INR4	
65	INL4	
66	INR5	
67	INL5	
68	INR6	
69	INL6	
70	INR7	
71	INL7	
72	INR8	
73	INL8	
74	NC	
75	INRA/RECR1	Input pin of L/R channel (Input selector) / Output pin for L/R channel REC output
76	INLA/RECL1	
77	NC	
78	INR9	Input pin of L/R channel (Input selector)
79	INL9	
80	NC	
81	INRB/RECR2	Input pin of L/R channel (Input selector) / Output pin for L/R channel REC output
82	INLB/RECL2	
83	INR10/RECR4	
84	INL10/RECL4	
85	INR11/RECR5	
86	INL11/RECL5	
87	NC	
88	NC	
89	NC	
90	RECR3	Output pin for L/R channel REC output
91	RECL3	
92	NC	
93	FLIN1	Input pin of L/R/C/SW/SL/SR/SBL/SBR channel (Multi IN 1/2)
94	FRIN1	
95	CIN1	
96	SWIN1	
97	SLIN1	
98	SRIN1	
99	SBLIN1	
100	SBRIN1	

**IC603:** M66003-0131FP-R (OPERATION P.C.B.)  
18 digit 5x7 segment VFD controller/driver

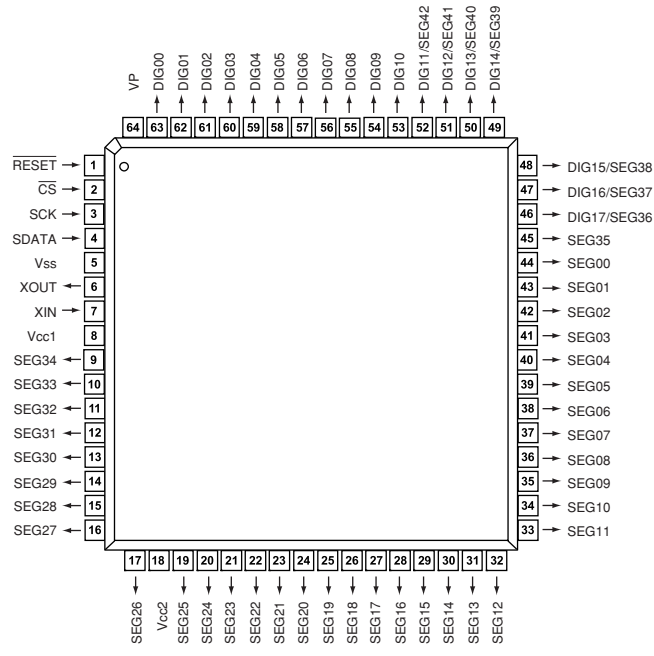
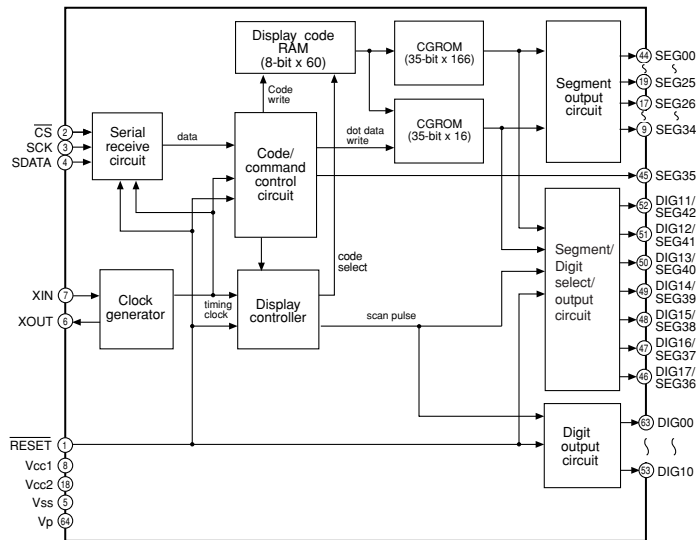

RX-V563/HTR-6150/  
DSP-AX563

Pin No.	Port Name	Function Name	I/O	Detail of Function
1	/RESET	Reset	Reset input	When "L", M66003 is initialized
2	/CEFL	CS	Chip select input	When "L", communication with the MCU is possible When "H", any instruction from the MCU is neglected
3	CKFL	SCK	Shift clock input	Serial input data is taken and shifted by the positive edge of SCK
4	DTFL	SDATA	Serial data input	
5	VSS	Vss		GND (0V)
6	XOUT	XOUT	Clock output	When use as a CR oscillator, connect external resistor and capacitor / When use an external clock, input external clock to XIN, and XOUT must be opened
7	XIN	XIN	Clock input	
8	VDD	Vcc1		Positive power supply for internal logic
9	P11	SEG34	Segment output	Positive power supply for DIG and SEG outputs
10	P2	SEG33	Segment output	
11	P3	SEG32	Segment output	
12	P4	SEG31	Segment output	
13	P5	SEG30	Segment output	
14	P6	SEG29	Segment output	
15	P7	SEG28	Segment output	
16	P8	SEG27	Segment output	
17	P9	SEG26	Segment output	
18	VDD	Vcc2		
19	P10	SEG25	Segment output	Connect to segment (anode) pins of VFD
20	P11	SEG24	Segment output	
21	P12	SEG23	Segment output	
22	P13	SEG22	Segment output	
23	P14	SEG21	Segment output	
24	P15	SEG20	Segment output	
25	P16	SEG19	Segment output	
26	P17	SEG18	Segment output	
27	P18I	SEG17	Segment output	
28	P19	SEG16	Segment output	
29	P20	SEG15	Segment output	
30	P21	SEG14	Segment output	
31	P22	SEG13	Segment output	
32	P23	SEG12	Segment output	
33	P24	SEG11	Segment output	
34	P25	SEG10	Segment output	
35	P26	SEG09	Segment output	
36	P27	SEG08	Segment output	
37	P28	SEG07	Segment output	
38	P29	SEG06	Segment output	
39	P30	SEG05	Segment output	
40	P31	SEG04	Segment output	
41	P32	SEG03	Segment output	
42	P33	SEG02	Segment output	
43	P34	SEG01	Segment output	
44	P35	SEG00	Segment output	
45	P36	SEG35	Segment output	
46	P37	DIG17/SEG36	Segment output	Connect to digit (grid) pins of VFD
47	G17I	DIG16/SEG37	Digit output	
48	G16I	DIG15/SEG38	Digit output	
49	G15I	DIG14/SEG39	Digit output	
50	G14	DIG13/SEG40	Digit output	
51	G13	DIG12/SEG41	Digit output	
52	G12	DIG11/SEG42	Digit output	
53	G11	DIG10	Digit output	
54	G10	DIG09	Digit output	
55	G9	DIG08	Digit output	
56	G8	DIG07	Digit output	
57	G7	DIG06	Digit output	
58	G6	DIG05	Digit output	
59	G5	DIG04	Digit output	
60	G4	DIG03	Digit output	
61	G3	DIG02	Digit output	
62	G2	DIG01	Digit output	
63	G1	DIG00	Digit output	
64	VP	Vp		Negative power supply to pull down

MEMO



RX-V563/HTR-6150/  
DSP-AX563



1 ■ BLOCK DIAGRAMS

AUDIO (DIGITAL) SECTION BLOCK DIAGRAM

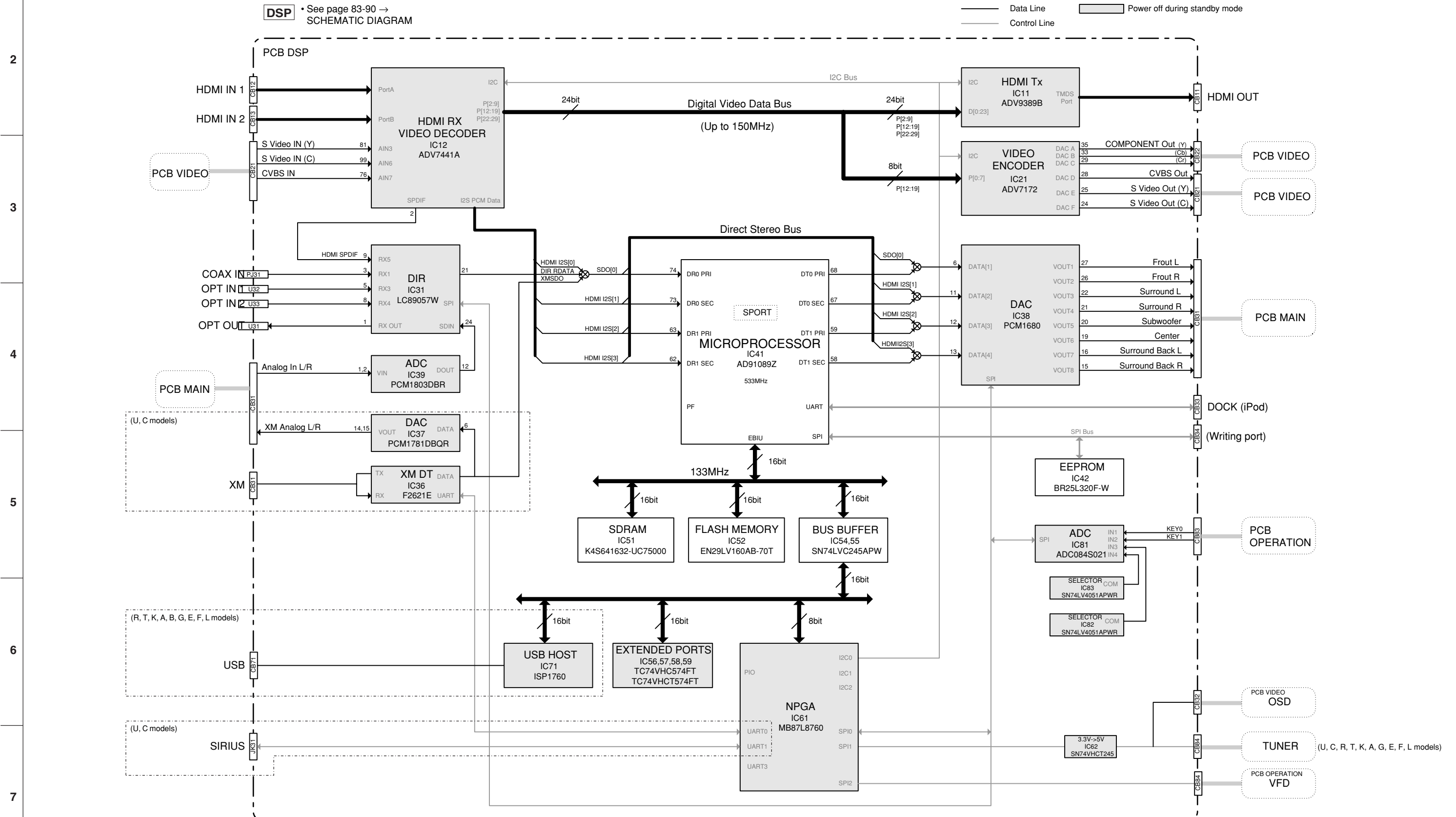

DSP CONTROL SECTION BLOCK DIAGRAM

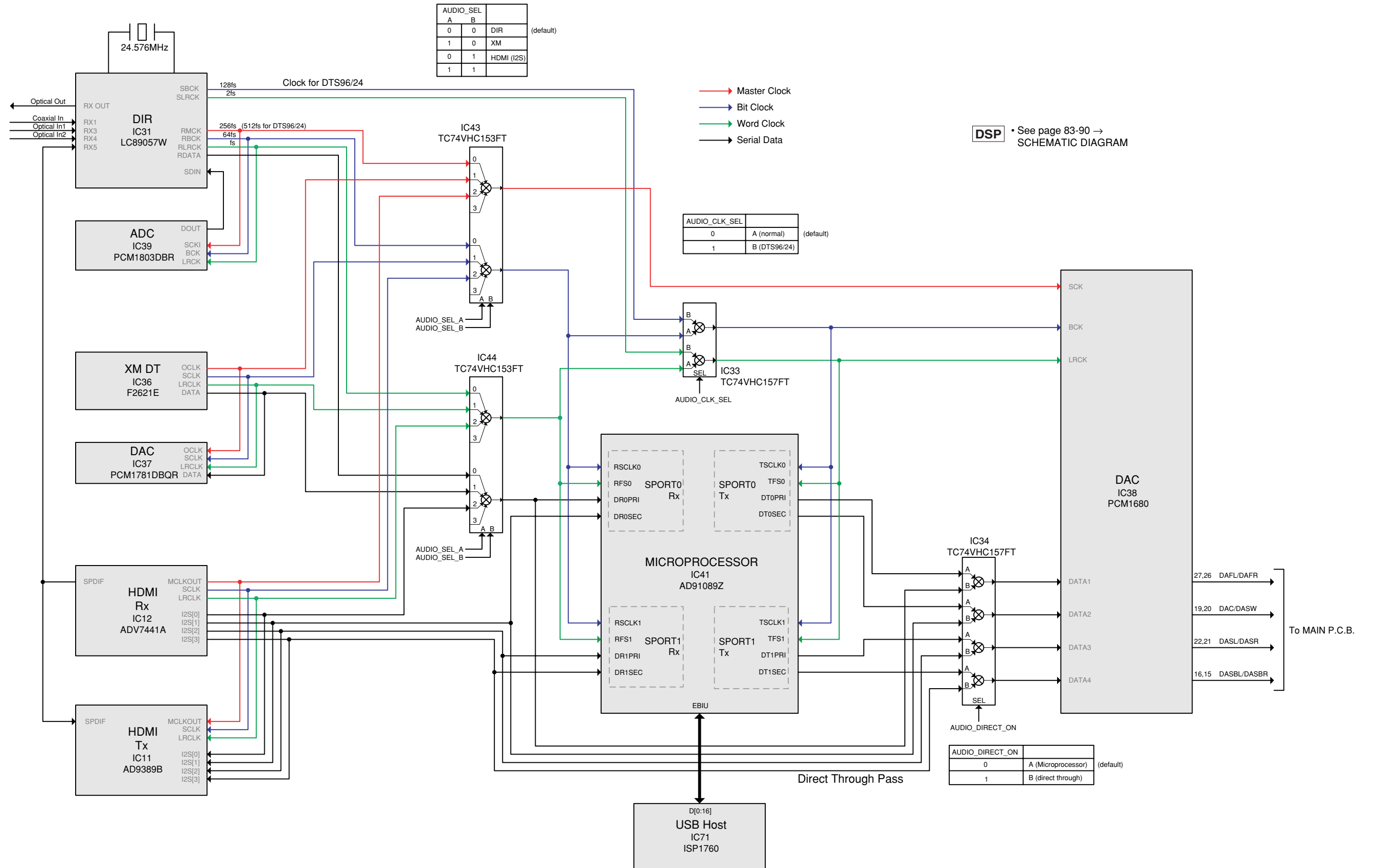

### AUDIO (ANALOG) / POWER SUPPLY SECTION BLOCK DIAGRAM

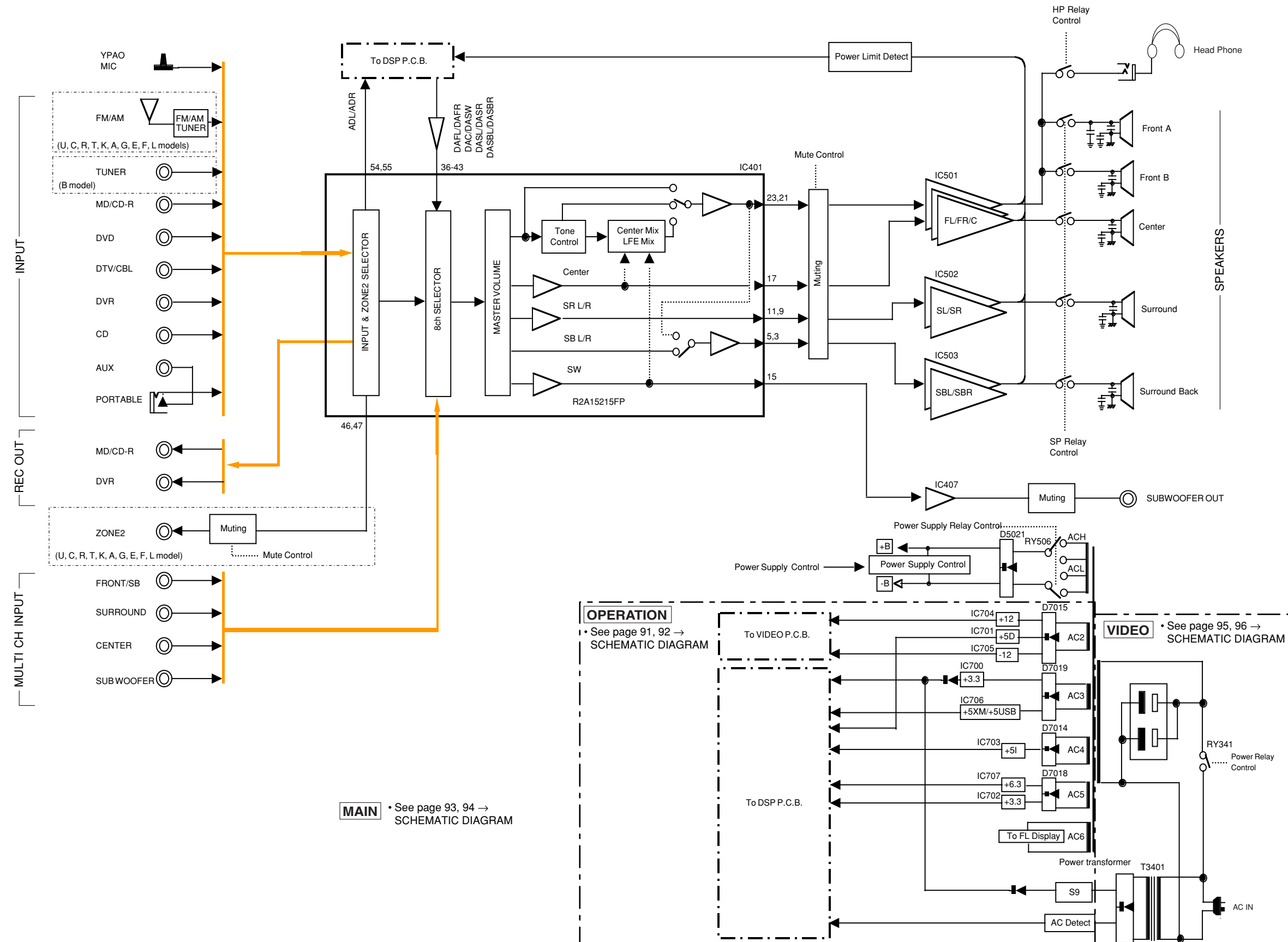

VIDEO SECTION BLOCK DIAGRAM

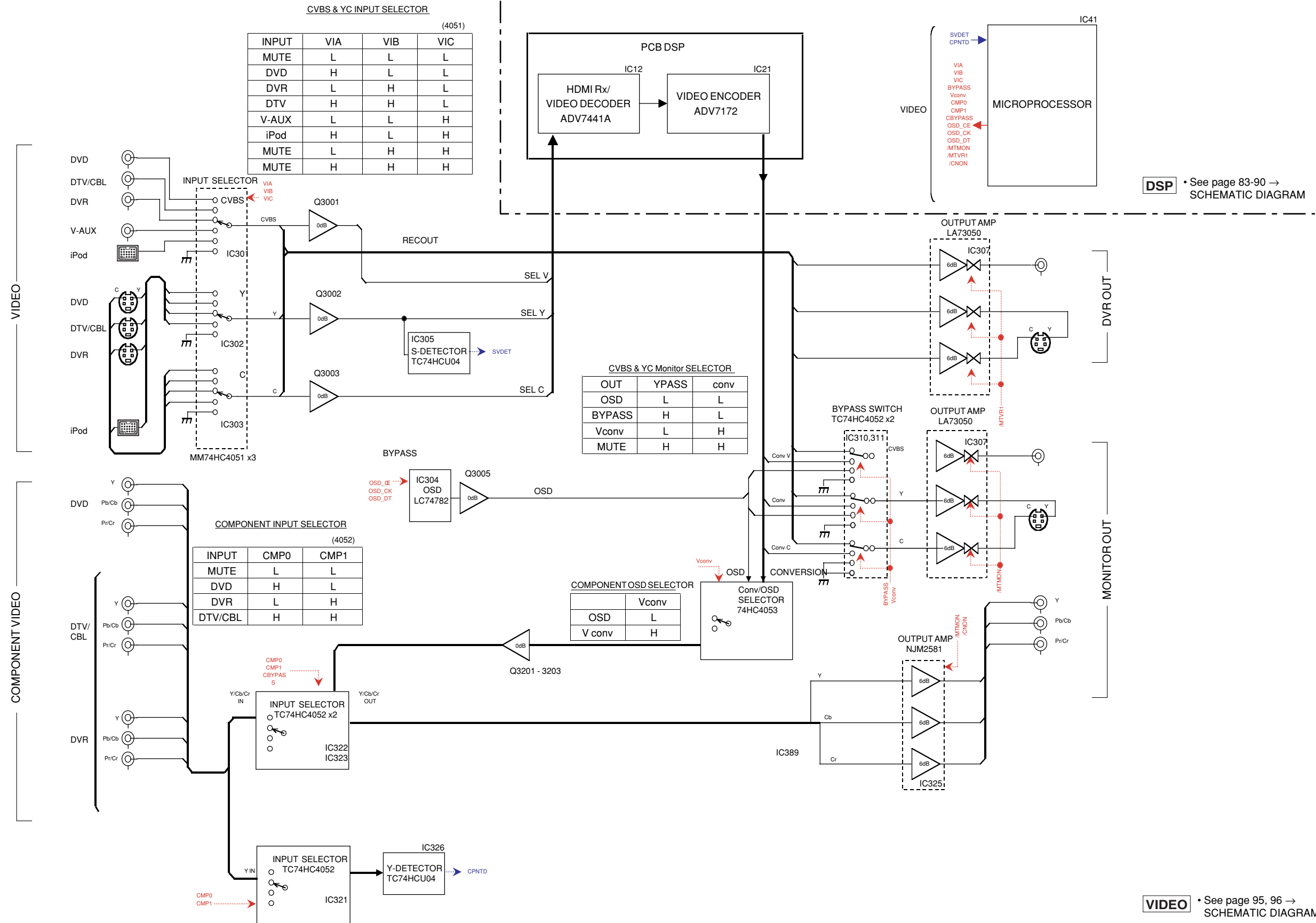

**DSP** • See page 83-90 → SCHEMATIC DIAGRAM

**VIDEO** • See page 95, 96 → SCHEMATIC DIAGRAM



CONTROL SECTION BLOCK DIAGRAM

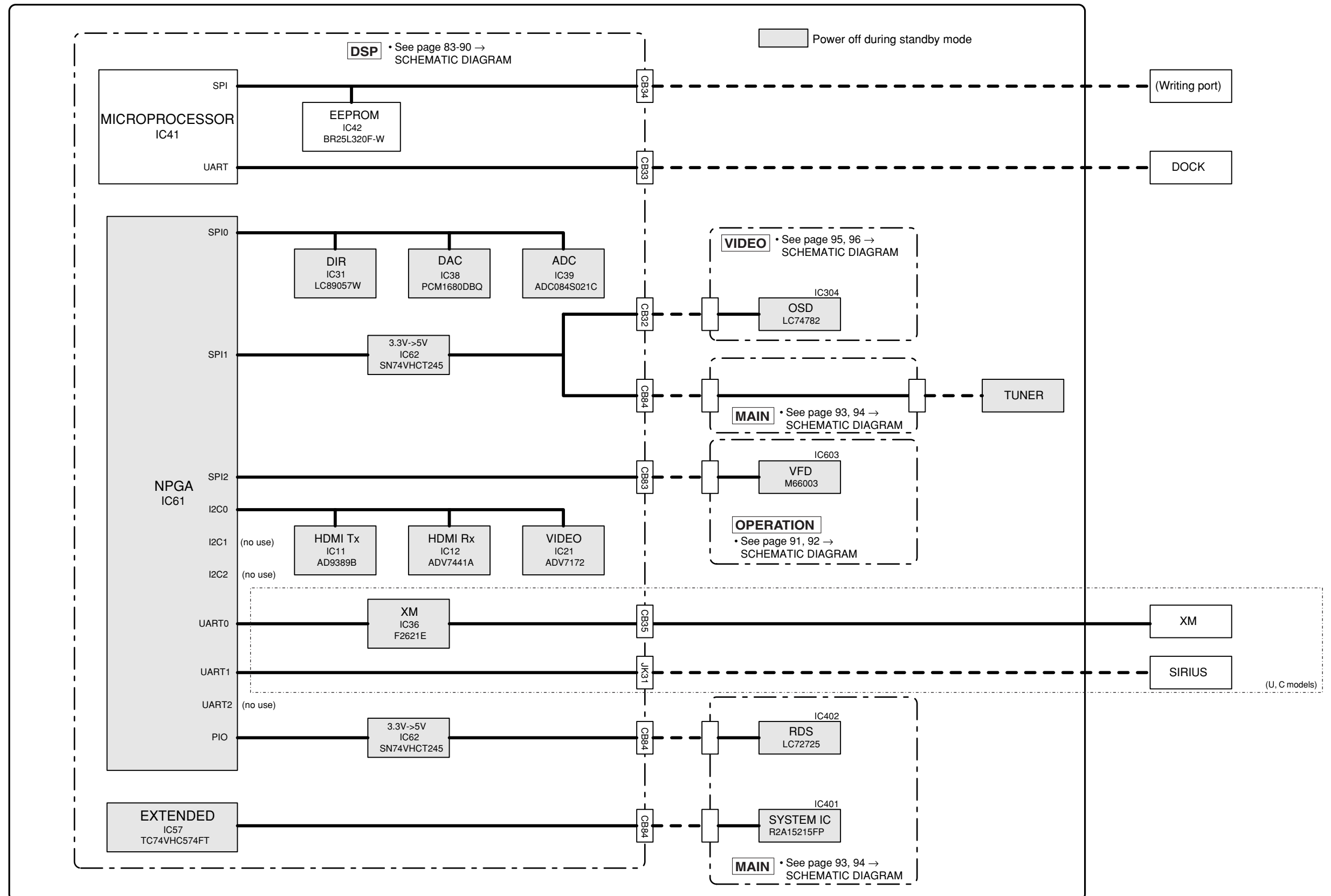

PRINTED CIRCUIT BOARDS

DSP P.C.B. (Side A)

Semiconductor Location

Ref no.	Location	Ref no.	Location
D109	E2	IC12	D3
D110	D2	IC13	D3
D111	D2	IC21	D4
D112	D2	IC22	D4
D113	D2	IC31	G3
D114	D2	IC33	G3
D115	D2	IC34	F3
D116	D2	IC36	G3
D117	D2	IC37	H3
D118	D2	IC38	H4
D119	D2	IC39	G4
D120	D2	IC41	F4
D121	D2	IC42	F3
D122	D2	IC43	F3
D123	D2	IC44	G3
D124	D2	IC51	G5
D125	D2	IC52	G5
D126	D2	IC53	F5
D127	C2	IC54	F4
D128	C2	IC55	F4
D129	C2	IC56	D5
D130	D2	IC57	H4
D131	C2	IC58	H5
D132	C2	IC59	H5
D135	C2	IC61	E5
D136	D2	IC62	E6
D201	D4	IC71	D5
D305	H2	IC72	F5
D306	H2	IC73	D6
D401	E4	IC81	H5
D503	G5	IC82	H6
D801	H6	IC83	H6
D802	H6	IC151	G6
D803	H6	IC152	G6
D804	H6	IC153	G6
D805	H6	IC154	G6
D806	H6	IC155	G6
D1301	G2	Q301	H2
D1302	G2	Q401	E5
IC11	E3	Q801	F6

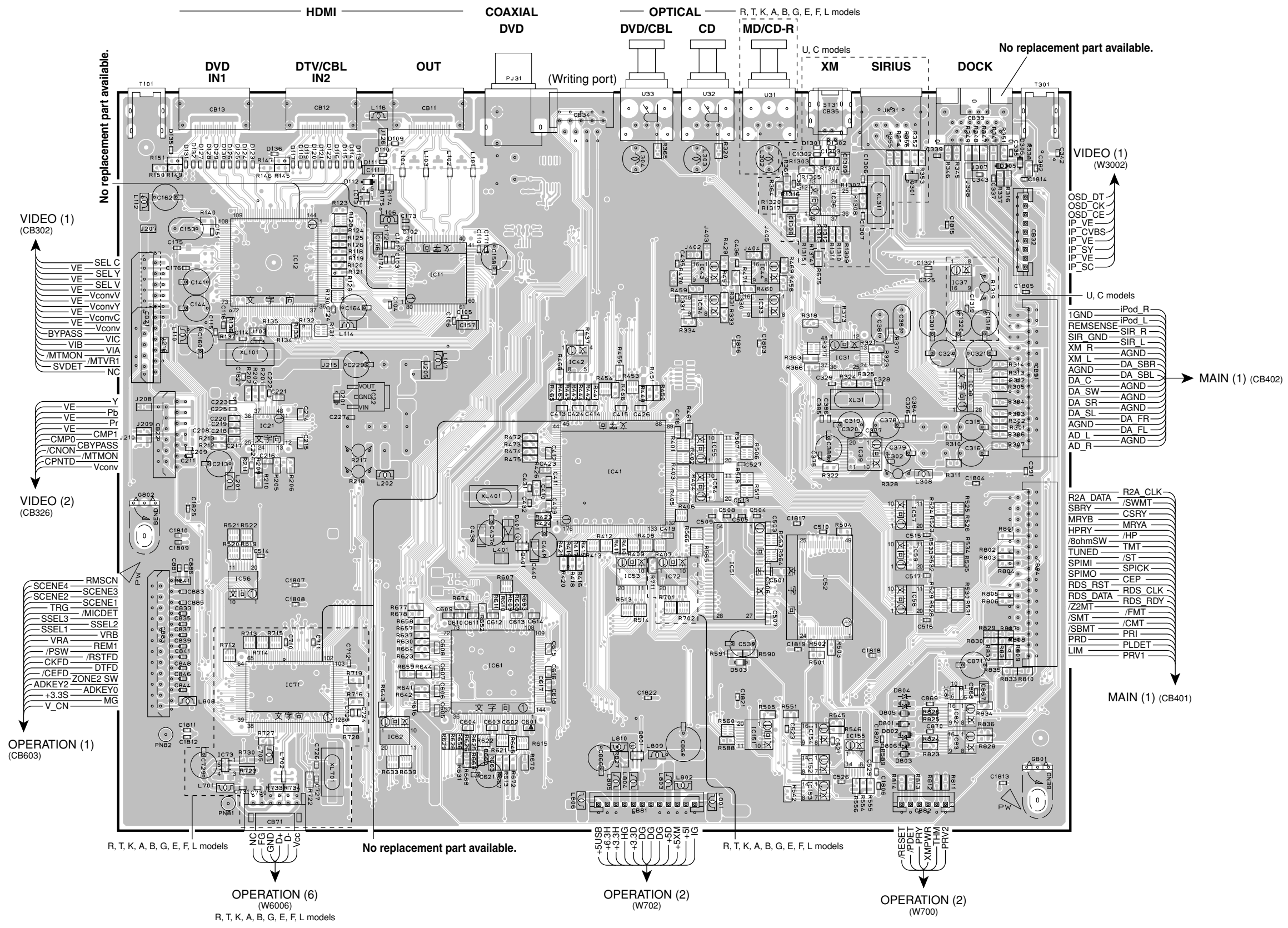

- VE SEL C
- VE SEL Y
- VE SEL V
- VE VconvV
- VE VconvY
- VE VconvC
- VE VconvC
- BYPASS VIC
- VIB VIA
- /MTMON /MTVR1
- SVDET NC

- VE Y
- VE Pb
- VE Pr
- VE CMP1
- CMPO CBYPASS
- /CNON /MTMON
- CPNTD Vconv

- SCENE4 RMSCN
- SCENE2 SCENE3
- SCENE1 SCENE1
- TRG /MICDET
- SSEL3 SSEL2
- SSEL1 SSEL2
- VRA VRB
- /PSW REM1
- /RSTFD /RSTFD
- CKFD DTFD
- /CEFD ZONE2 SW
- ADKEY2 ADKEY0
- +3.3S MG
- V\_CN

- VIDEO (1) (W3002)
- OSD\_DT
- OSD\_CK
- OSD\_CE
- IP\_VE
- IP\_CVBS
- IP\_VE
- IP\_SY
- IP\_VE
- IP\_SC

- U, C models
- 1GND iPod R
- REMSENSE iPod L
- SIR\_R SIR R
- SIR\_GND SIR L
- XM\_R AGND
- XM\_L DA SBR
- AGND DA SBL
- DA\_C AGND
- DA\_SW AGND
- DA\_SL AGND
- AGND DA FR
- AD\_L DA FL
- AD\_R AGND

- R2A\_DATA R2A\_CLK
- SBRY /SWMT
- MRYB CSRY
- HPRY MRYA
- /8ohmSW /HP
- TUNED TMT
- SPIMI /ST
- SPIMO SPICK
- RDS\_RST RDS\_CLK
- RDS\_DATA RDS\_RDY
- Z2MT /FMT
- /SMT /CMT
- /SBMT PRI
- PRD PLDET
- LIM PRV1

DSP P.C.B. (Side B)

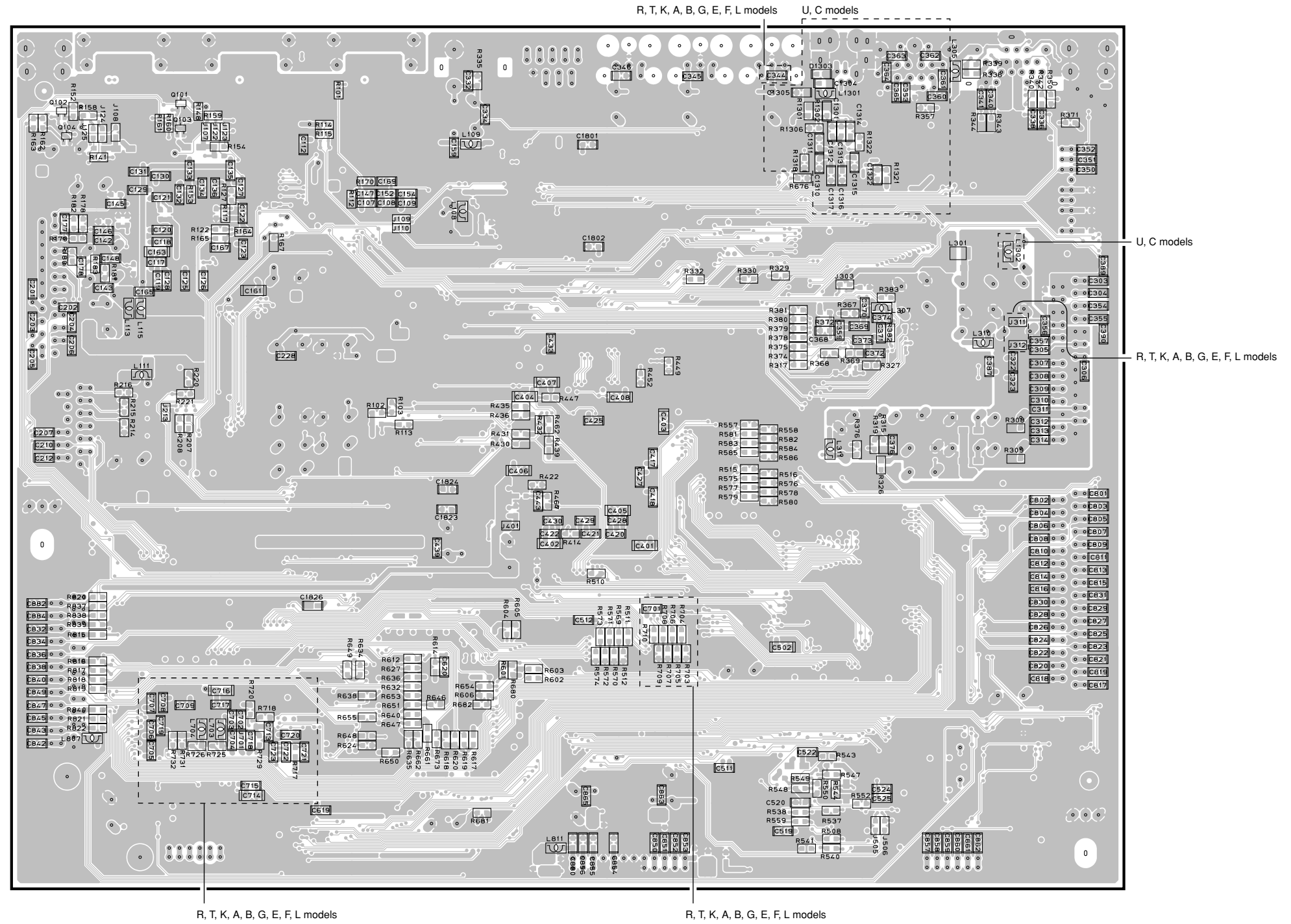

• Semiconductor Location

Ref no.	Location
D1303	G2
Q101	D2
Q102	C2
Q103	D2
Q104	C2

**OPERATION (1) P.C.B.** (Side A)

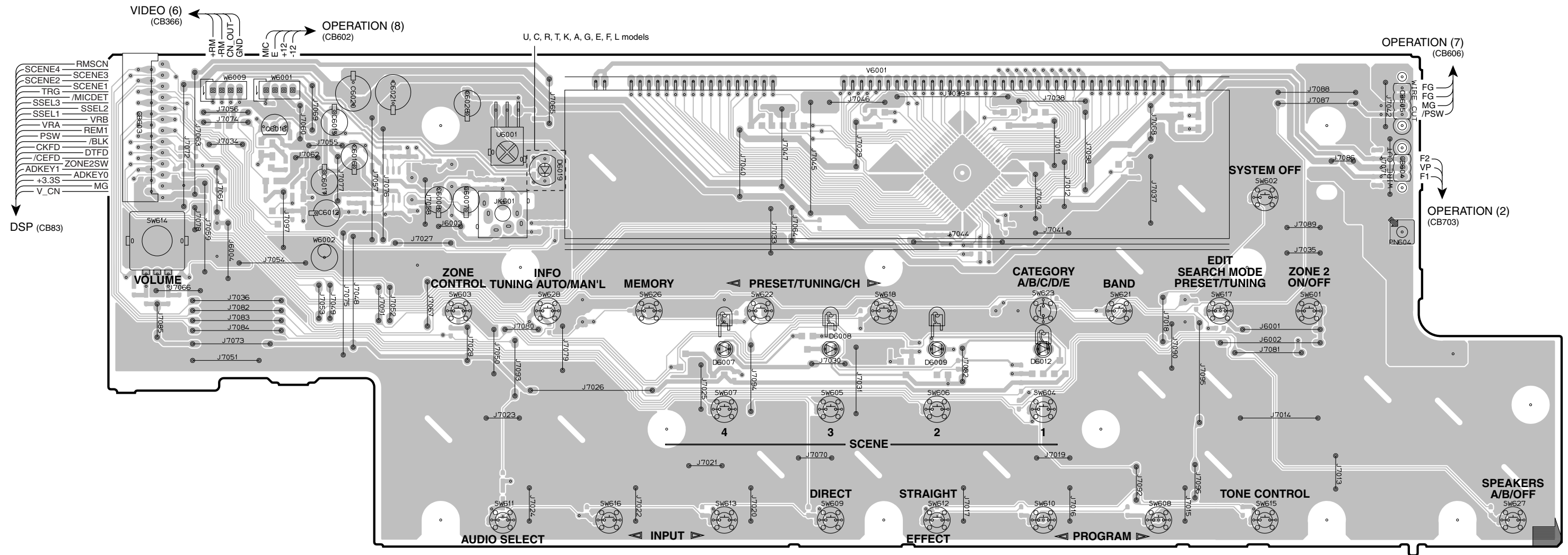

• Semiconductor Location

Ref no.	Location
D6007	E4
D6008	F4
D6009	G4
D6012	G4
D6019	D3
Q6016	B3

Circuit No.	U, C, R, T, K, A, G, E, F, L	B
SW601-603, 617, 618, 621, 622, 625, 626, 628	O	X
J6002	O	X

**OPERATION (1) P.C.B.** (Side B)

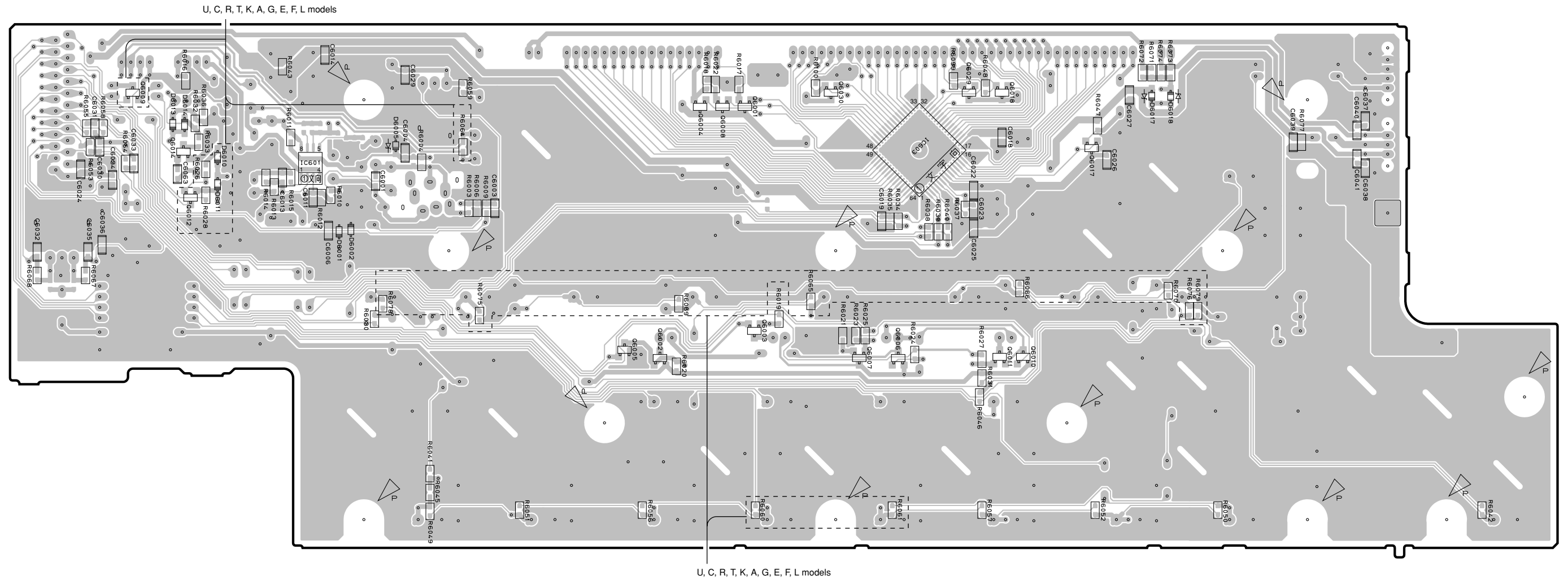

• **Semiconductor Location**

Ref no.	Location	Ref no.	Location	Ref no.	Location	Ref no.	Location
D6001	C4	IC601	C3	Q6008	E3	Q6030	F3
D6002	C4	IC603	G3	Q6009	B3		
D6005	D3	Q6001	F3	Q6010	G4		
D6010	C3	Q6002	E4	Q6011	G4		
D6011	C3	Q6003	F4	Q6012	B4		
D6013	B3	Q6004	E3	Q6014	B3		
D6014	B3	Q6005	E4	Q6017	H3		
D6017	H3	Q6006	G4	Q6018	G3		
D6018	H3	Q6007	F4	Q6029	G3		

**OPERATION (2) P.C.B.** (Side A)

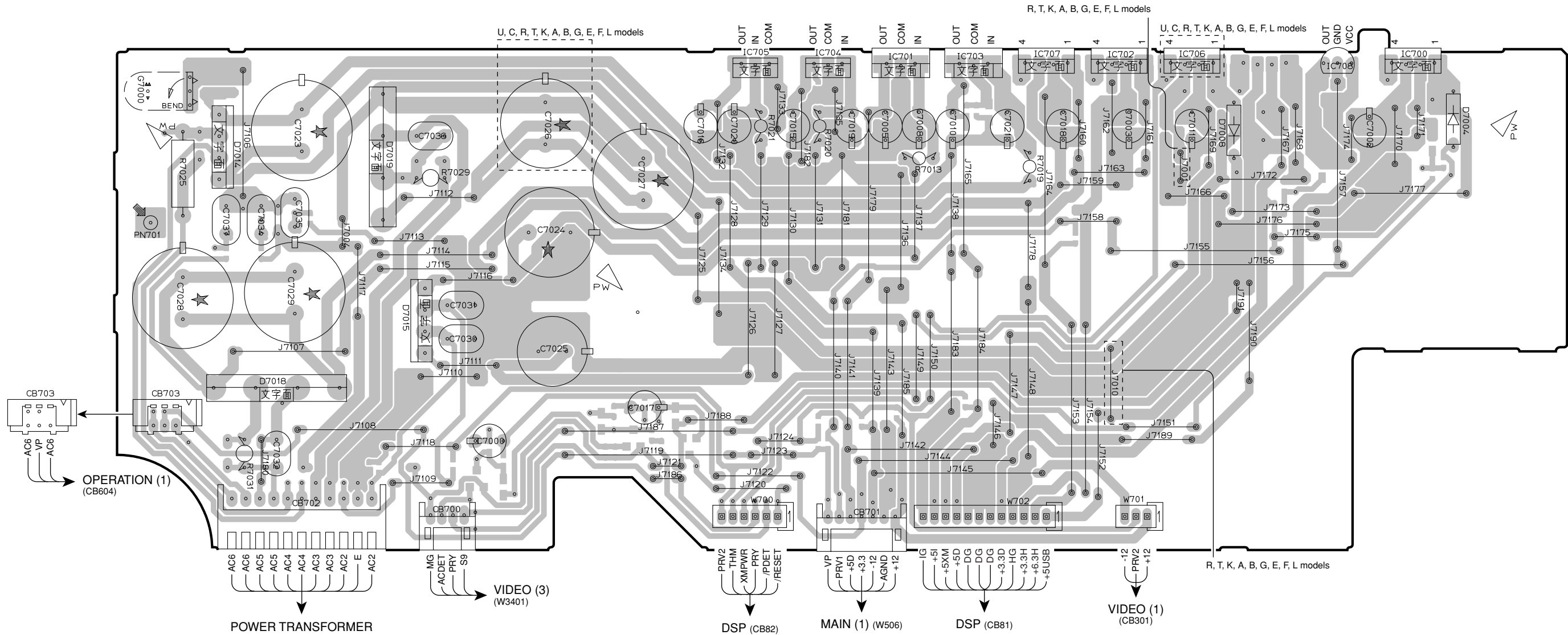

• **Semiconductor Location**

Ref no.	Location	Ref no.	Location
D7004	I3	IC702	H2
D7008	H3	IC703	G2
D7014	B3	IC704	F2
D7015	C4	IC705	E2
D7018	C4	IC706	H2
D7019	C3	IC707	G2
IC700	I2	IC708	I2
IC701	F2		

**OPERATION (2) P.C.B.** (Side B)

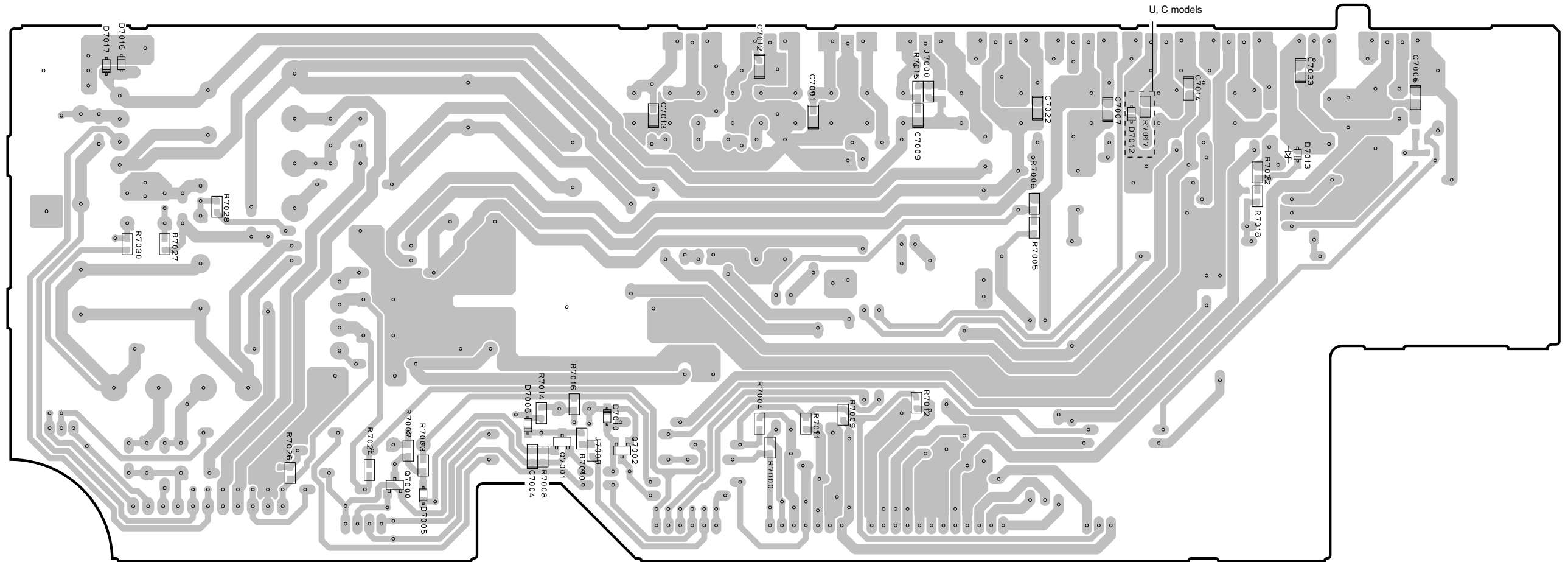

• **Semiconductor Location**

Ref no.	Location	Ref no.	Location
D7005	D5	D7016	B3
D7006	D4	D7017	B3
D7010	E4	Q7000	D5
D7012	H3	Q7001	E5
D7013	I3	Q7002	E5

**OPERATION (3) P.C.B.** (Side A)

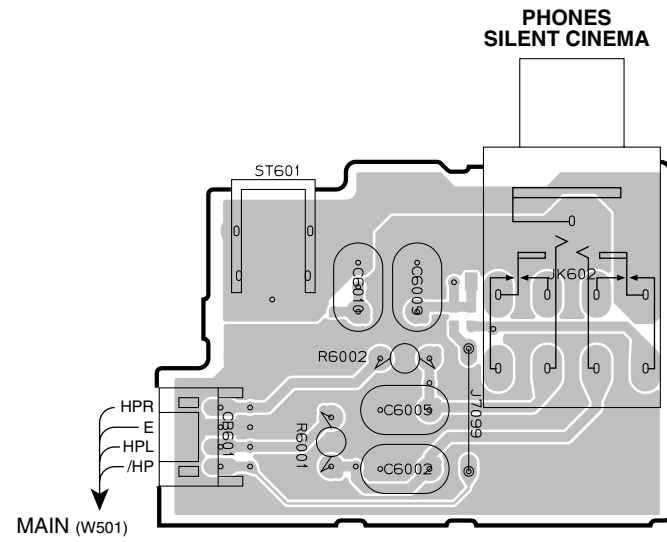

**OPERATION (3) P.C.B.** (Side B)

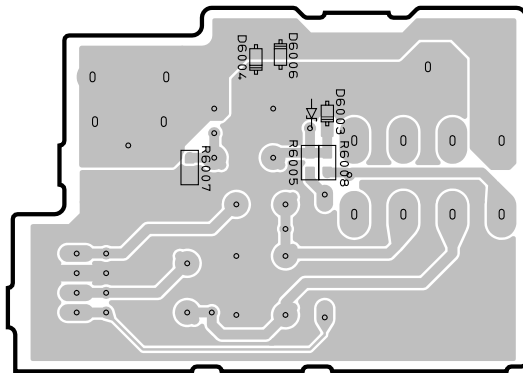

**OPERATION (4) P.C.B.** (Side A)

R, T, K, A, B, G, E, F, L models

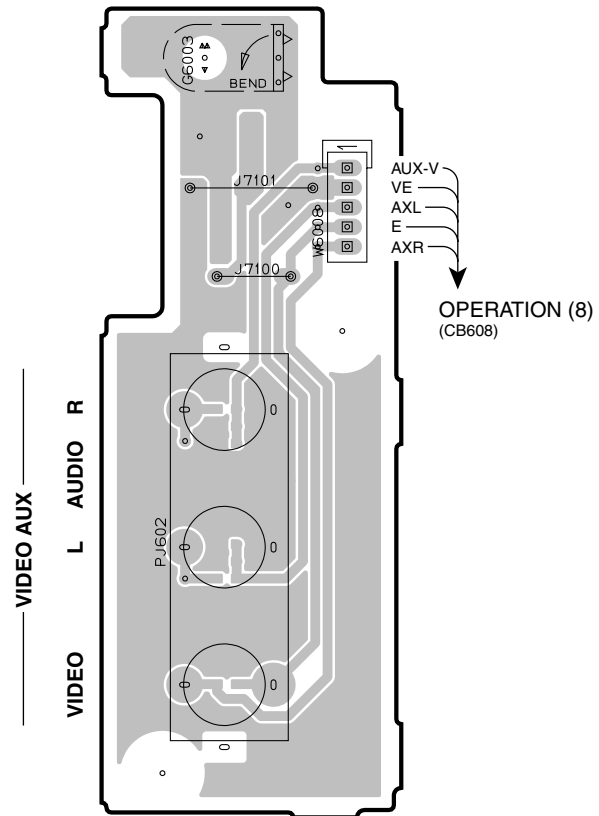

**OPERATION (4) P.C.B.** (Side B)

R, T, K, A, B, G, E, F, L models

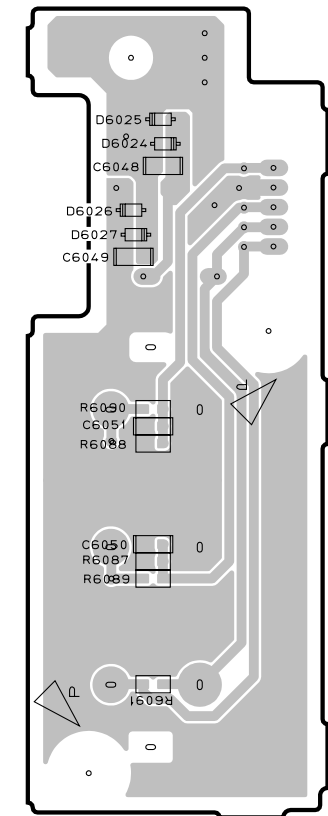

**OPERATION (5) P.C.B.** (Side A)

U, C models

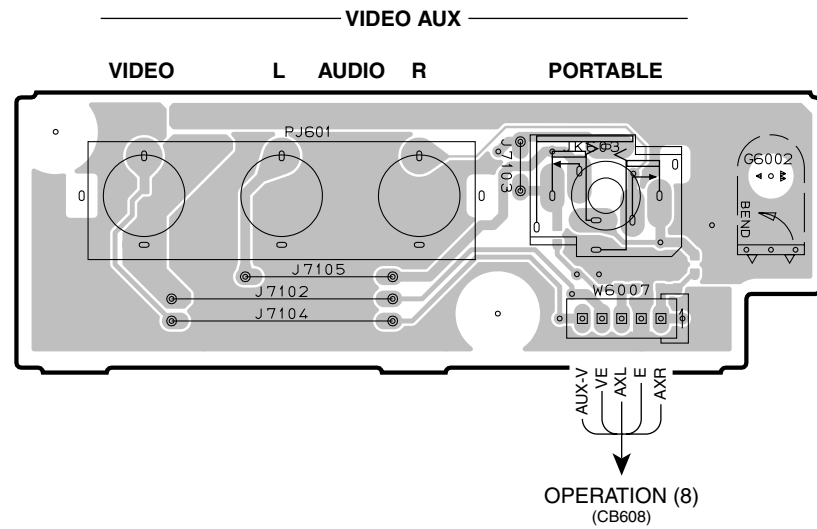

**OPERATION (5) P.C.B.** (Side B)

U, C models

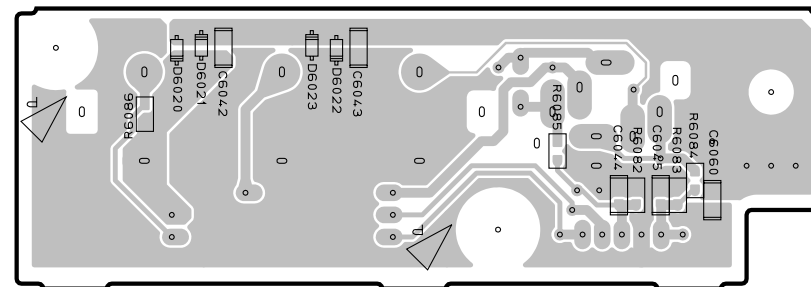

• **Semiconductor Location**

Ref no.	Location	Ref no.	Location
D6003	E2	D6023	F5
D6004	E2	D6024	I2
D6006	E2	D6025	I2
D6020	F5	D6026	I2
D6021	F5	D6027	I2
D6022	F5		



1  
2  
3  
4  
5  
6  
7

**OPERATION (6) P.C.B.** (Side A)

R, T, K, A, B, G, E, F, L models

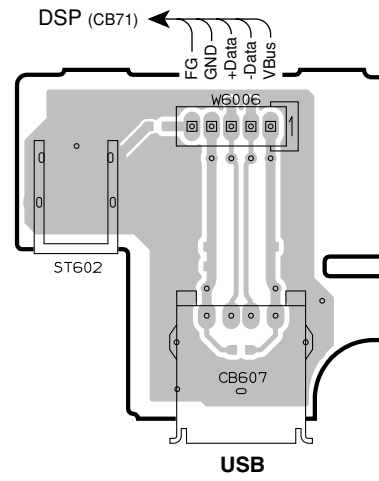

**OPERATION (6) P.C.B.** (Side B)

R, T, K, A, B, G, E, F, L models

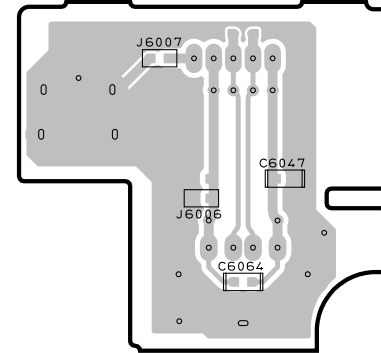

**OPERATION (7) P.C.B.** (Side A)

**MAIN ZONE ON/OFF**  
(U, C, R, T, K, A, G, E, F, L models)  
**STANDBY/ON**  
(B model)

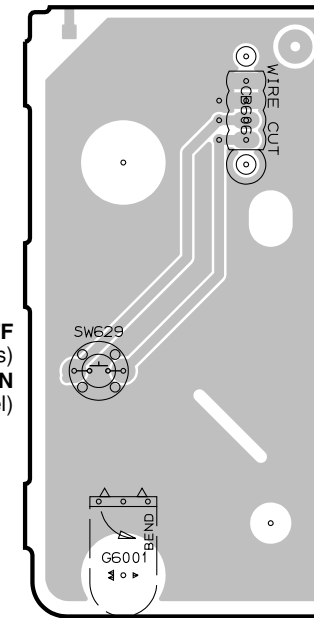

**OPERATION (7) P.C.B.** (Side B)

**OPERATION (1)**  
(CB605)

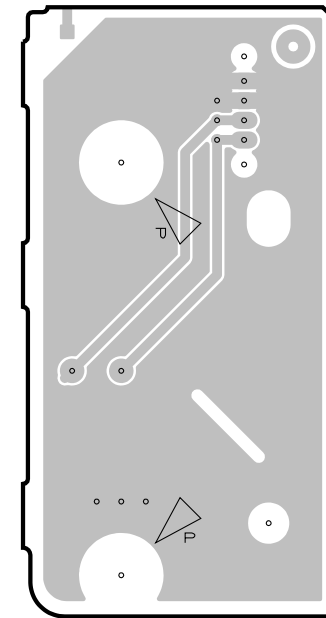

**OPERATION (8) P.C.B.** (Side A)

**OPERATION (8) P.C.B.** (Side B)

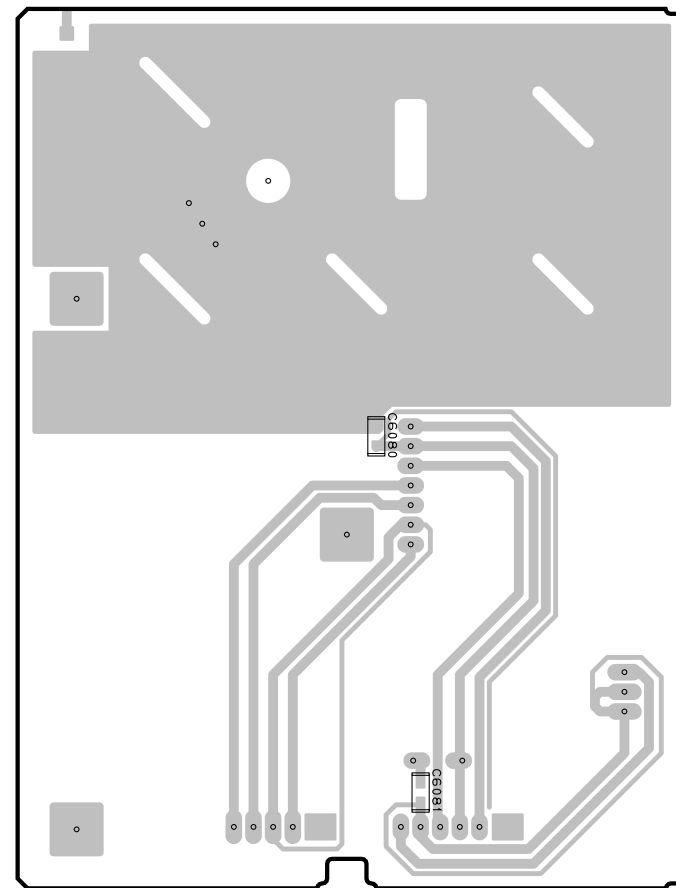
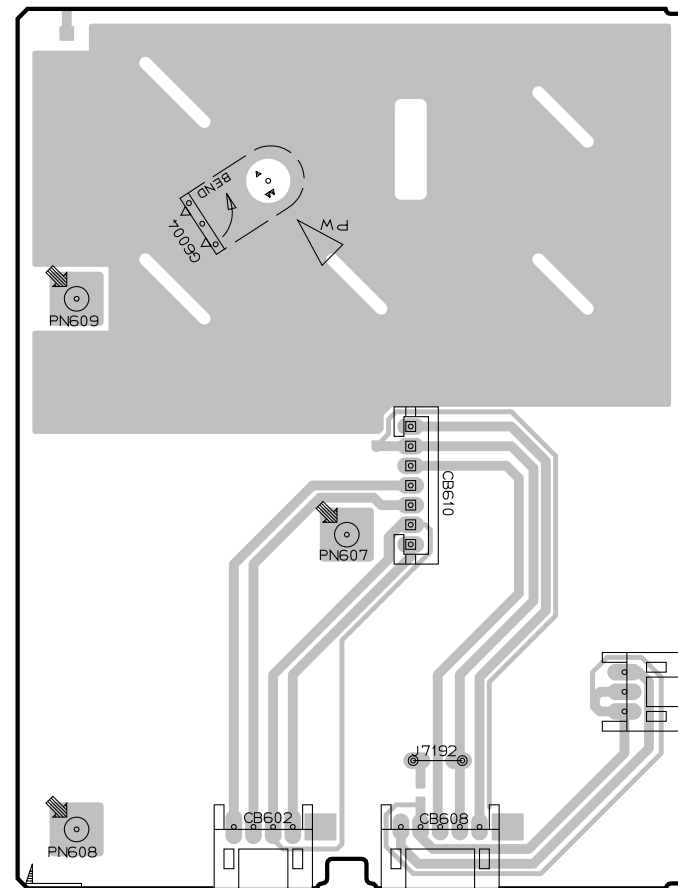

**OPERATION (4)** (W6008) (R, T, K, A, B, G, E, F, L models)  
**OPERATION (5)** (W6007) (U, C models)

**OPERATION (9) P.C.B.** (Side A)

(Side A)

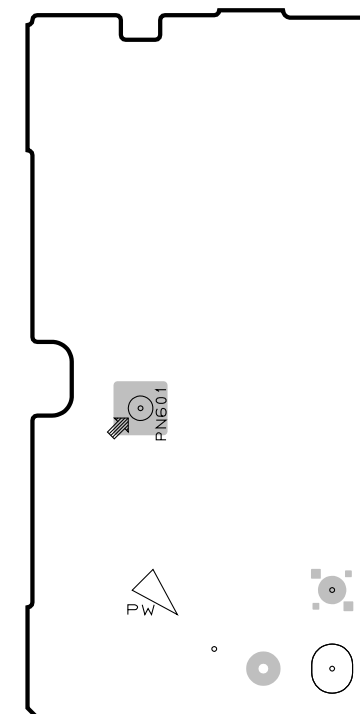

**OPERATION (9) P.C.B.** (Side B)

(Side B)

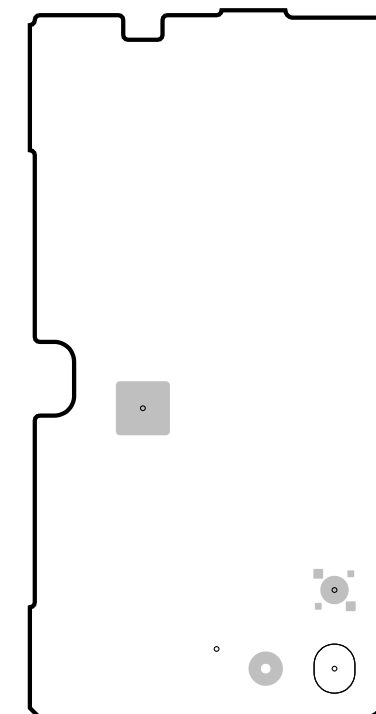

Circuit No.	U, C, R, T, K, A, L	G, E, F	B
C4037	O	O	X
C4109, 4123, 4126	X	O	X
Q4012	X	O	X
L4001	X	O	X
XL401	X	O	X

**MAIN (1) P.C.B.** (Side A)

**Semiconductor Location**

Ref no.	Location	Ref no.	Location	Ref no.	Location	Ref no.	Location	Ref no.	Location
D5001	D2	D5014	H3	D5024	D5	Q4012	G5	Q5021	G3
D5002	D2	D5015	I3	D5025	G3	Q5012	D2	Q5022	G2
D5005	E3	D5016	I3	D5026	G3	Q5013	D2	Q5023	I3
D5006	F3	D5017	C5	D5027	C5	Q5014	D2	Q5024	H2
D5007	G3	D5018	E5	IC501	I2	Q5015	D2	Q5025	E3
D5008	G3	D5019	E3	IC502	E2	Q5016	D2	Q5030	C5
D5010	I3	D5020	D5	IC503	G2	Q5017	D2	Q5031	G3
D5011	F3	D5021	D3	Q4009	H4	Q5018	I3		
D5012	E3	D5022	D5	Q4010	I5	Q5019	E3		
D5013	E5	D5023	D5	Q4011	G4	Q5020	F2		

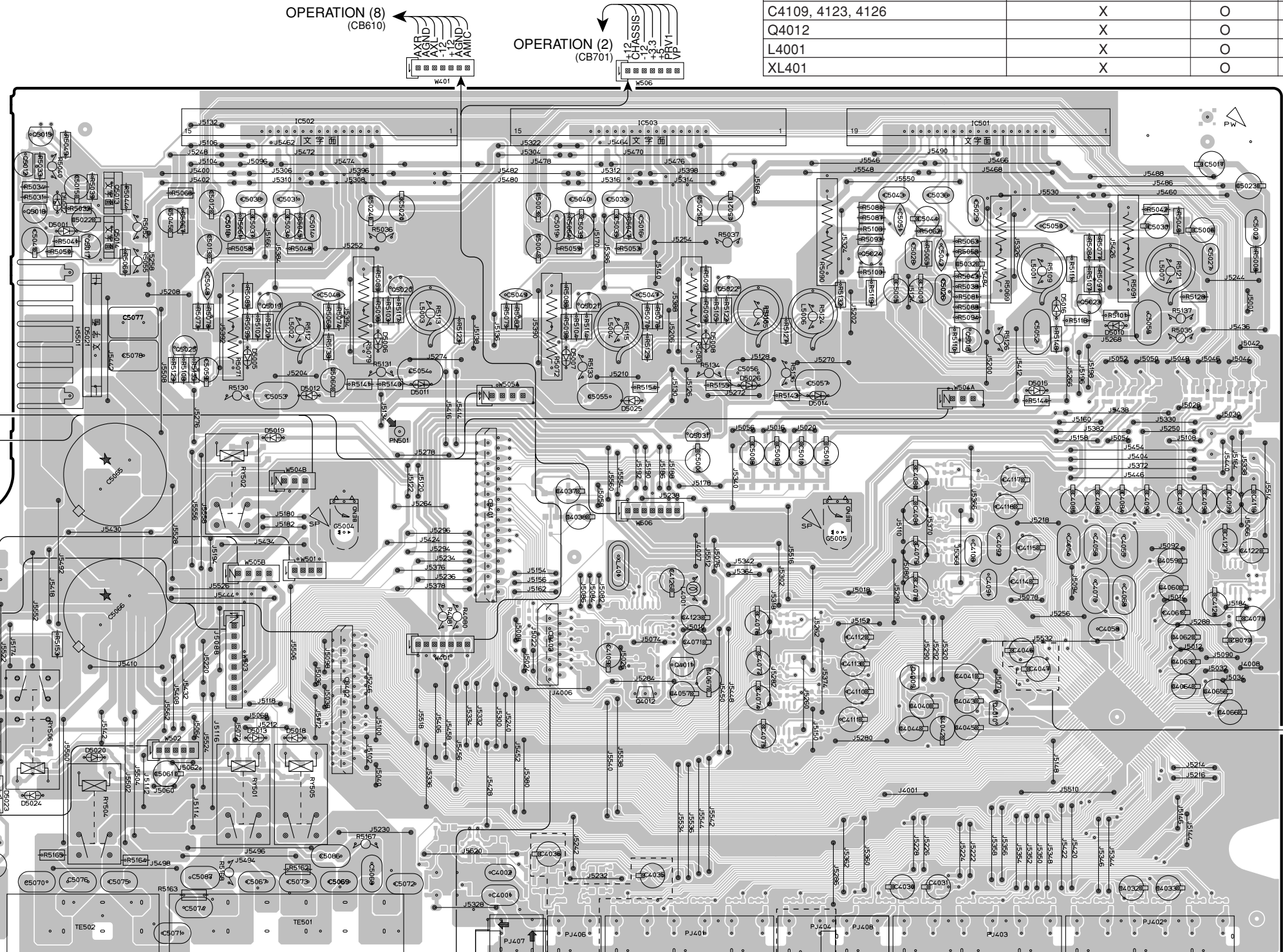

**MAIN (2) P.C.B.** (Side A)

**CAUTION:**  
 REPLACE FUSIBLE RESISTOR R7025  
 WITH SAME TYPE RNF1FB 1W 1.0Ω.  
**CAUTION:** REPLACE FUSIBLE  
 RESISTOR R7029, R7031  
 WITH SAME TYPE RS1BSJR 1W 0.15Ω.  
 X9591-2 GCI 1V0ASZ

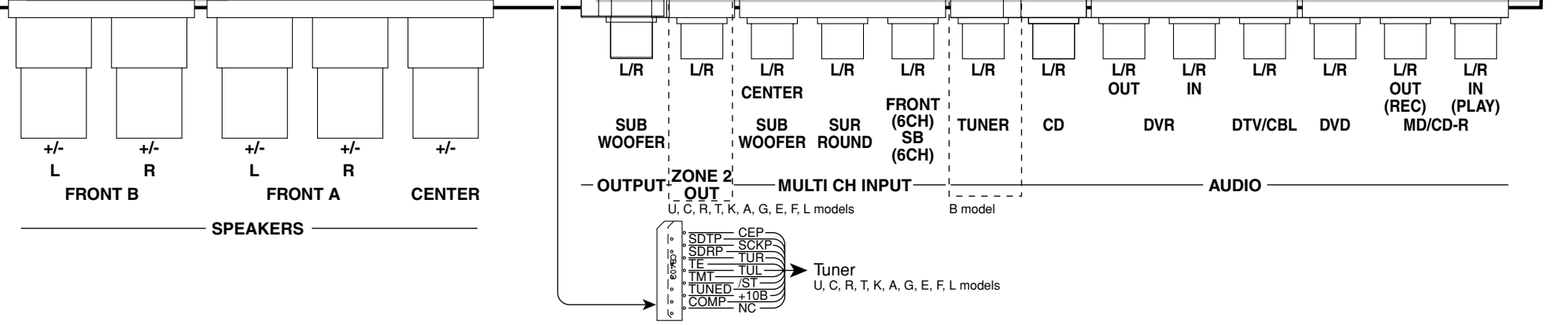

U, C, R, T, K, A, G, E, F, L models

**MAIN (1) P.C.B.** (Side B)

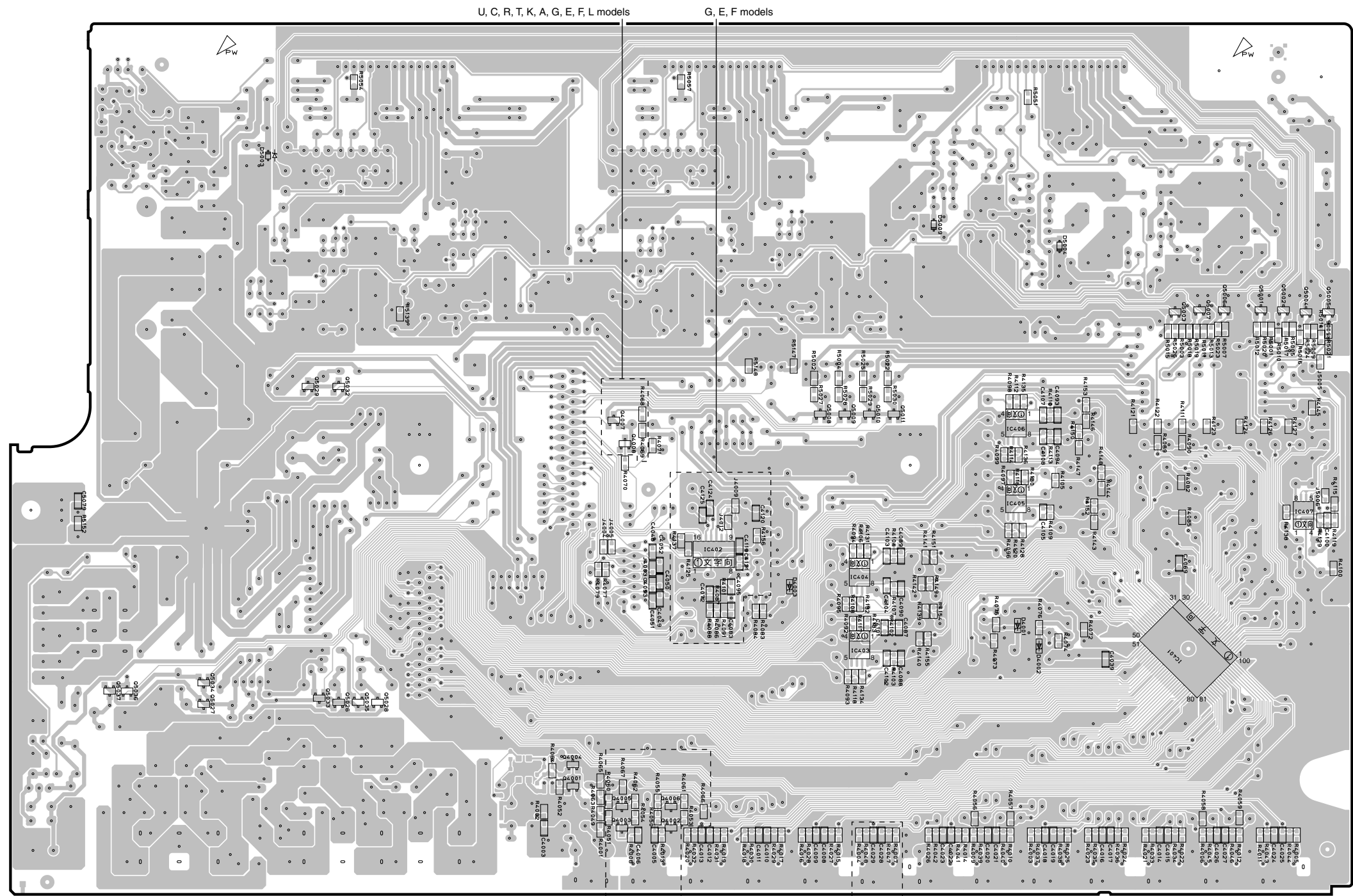

**MAIN (2) P.C.B.** (Side B)

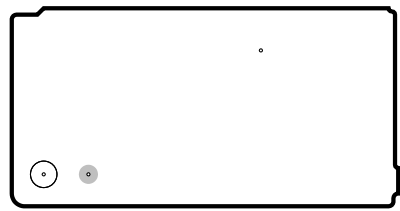

**Semiconductor Location**

Ref no.	Location	Ref no.	Location	Ref no.	Location	Ref no.	Location	Ref no.	Location
D4001	H5	IC404	G4	Q4006	F5	Q5007	H3	Q5032	D3
D4002	H5	IC405	H4	Q4007	E3	Q5008	G3	Q5033	D5
D4003	F4	IC406	H3	Q4008	E4	Q5009	G3	Q5034	C5
D5003	D2	IC407	I4	Q5001	I3	Q5010	G3	Q5035	D5
D5004	H3	Q4001	E5	Q5002	I3	Q5011	G3	Q5036	C5
D5009	G2	Q4002	F6	Q5003	H3	Q5026	D5	Q5037	C5
IC401	H5	Q4003	E6	Q5004	I3	Q5027	C5		
IC402	F4	Q4004	E5	Q5005	I3	Q5028	D5		
IC403	G5	Q4005	E5	Q5006	I3	Q5029	D3		

VIDEO (1) P.C.B. (Side A)

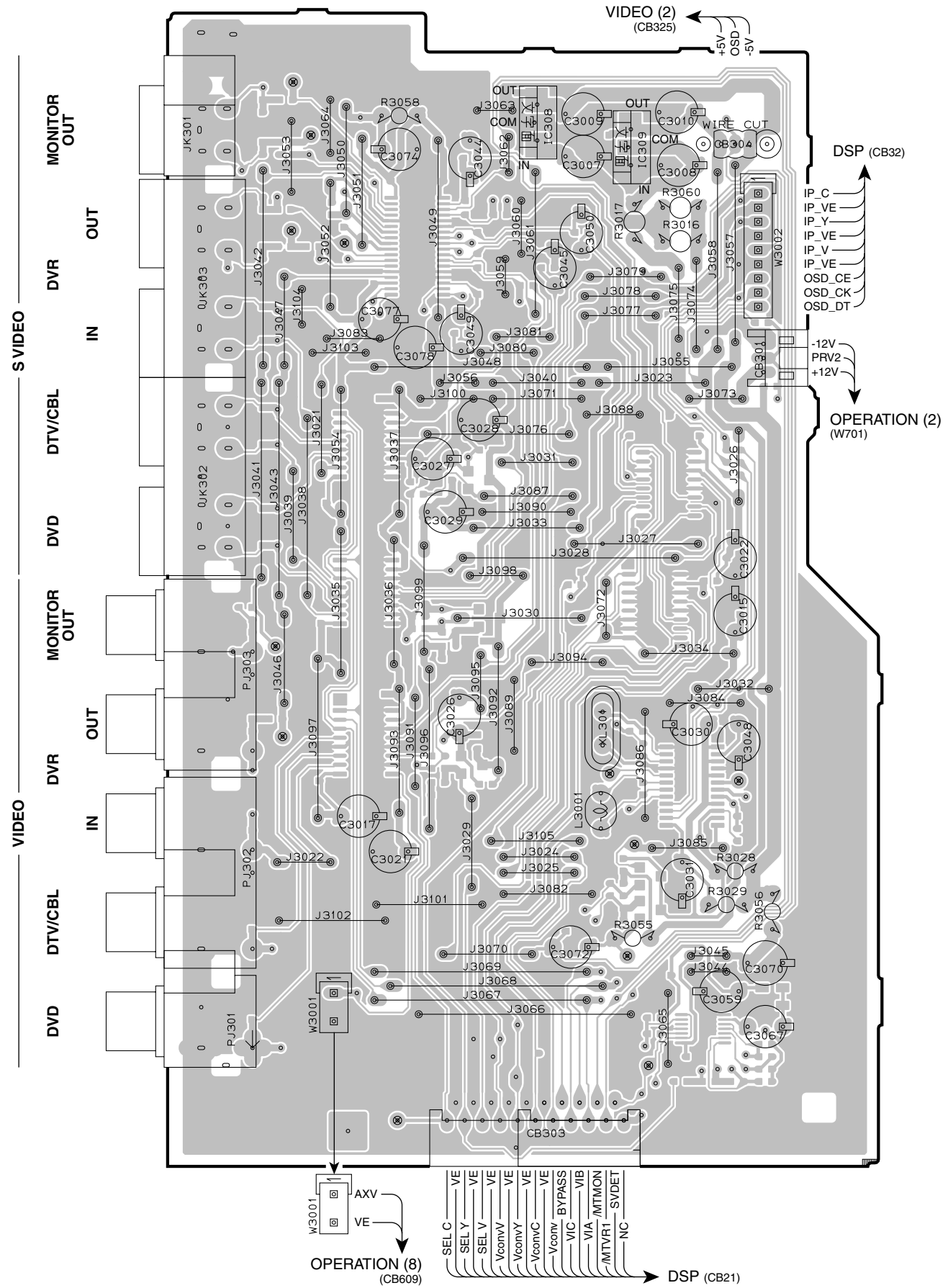

VIDEO (1) P.C.B. (Side B)

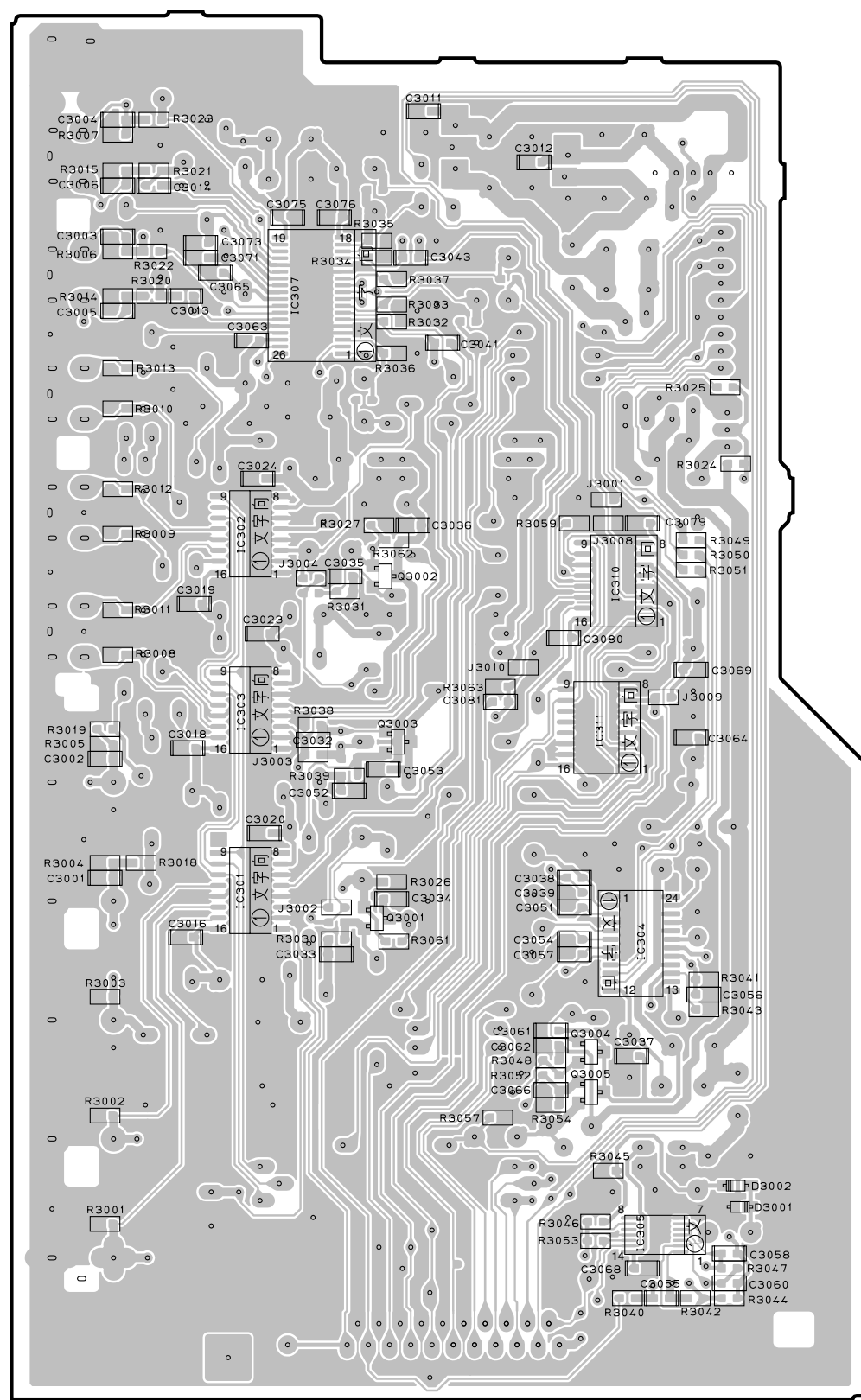

• Semiconductor Location

Ref no.	Location
D3001	I6
D3002	I6
IC301	G5
IC302	G3
IC303	G4
IC304	H5
IC305	I6
IC307	G2
IC308	D2
IC309	D2
IC310	H4
IC311	H4
Q3001	G5
Q3002	G3
Q3003	H4
Q3004	H5
Q3005	H5

**VIDEO (2) P.C.B.** (Side A)

**VIDEO (2) P.C.B.** (Side B)

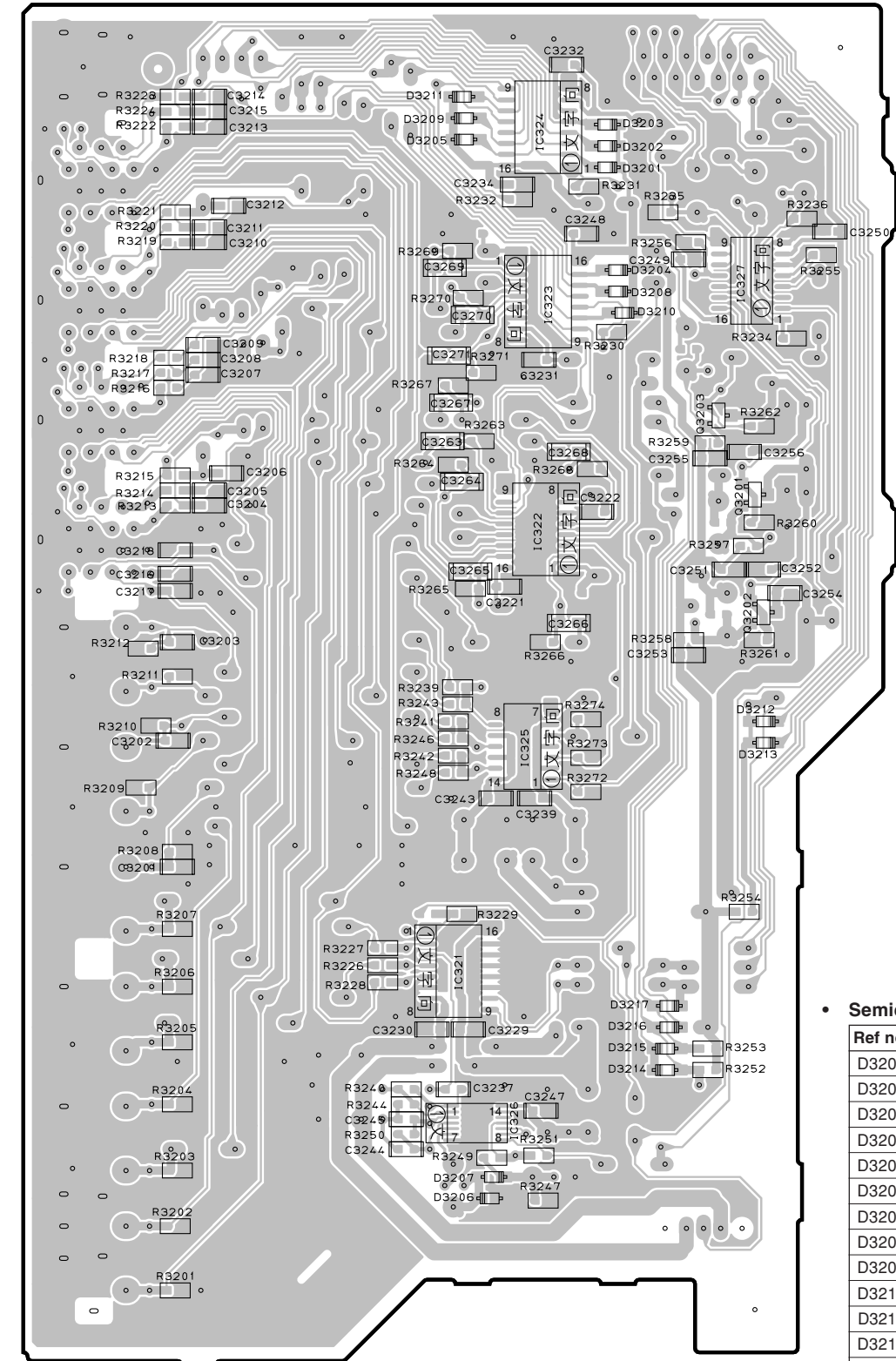
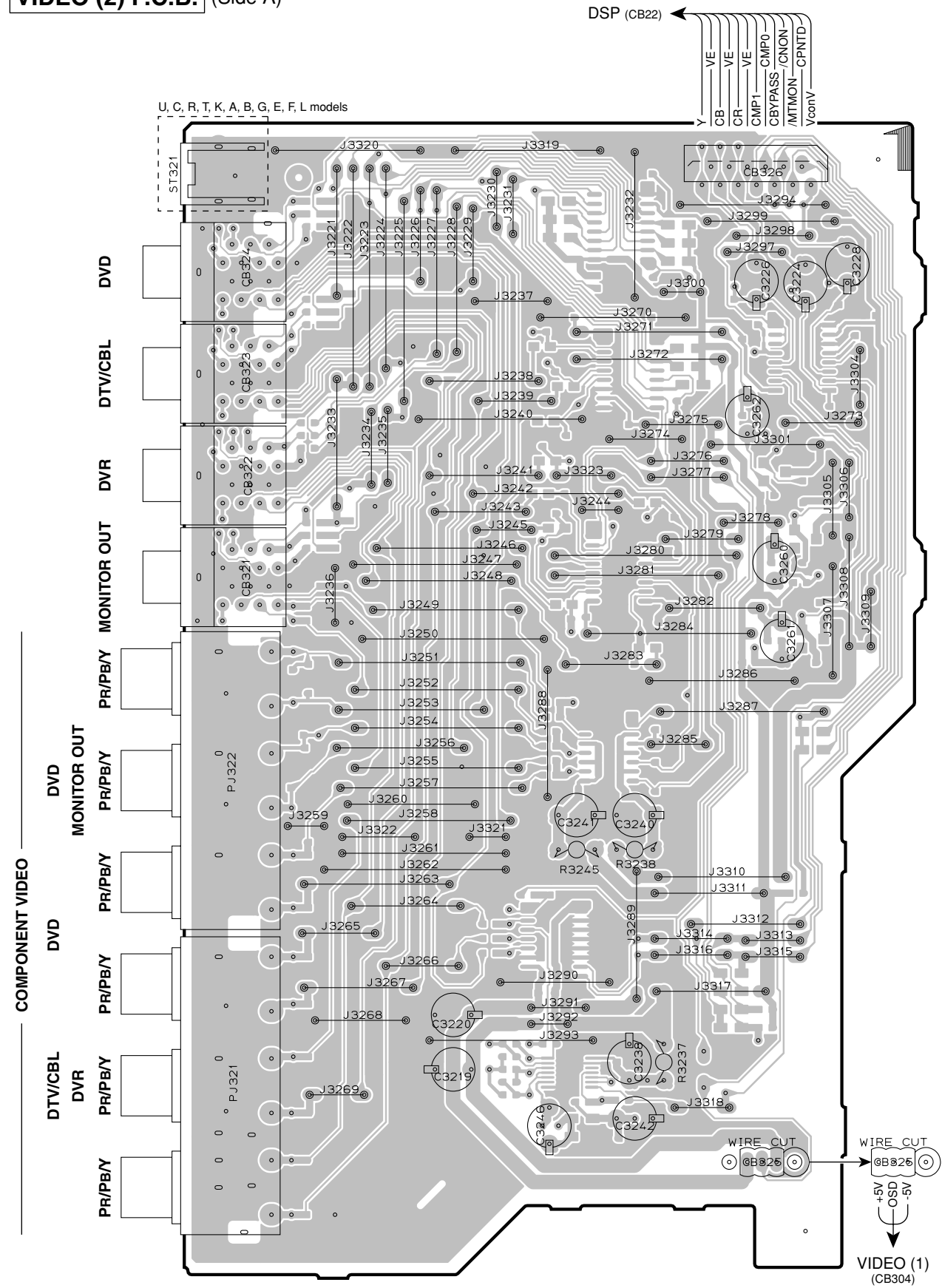

• **Semiconductor Location**

Ref no.	Location	Ref no.	Location
D3201	H2	D3215	I6
D3202	H2	D3216	I6
D3203	H2	D3217	I6
D3204	H3	IC321	H6
D3205	H2	IC322	H4
D3206	H6	IC323	H3
D3207	H6	IC324	H2
D3208	H3	IC325	H5
D3209	H2	IC326	H6
D3210	H3	IC327	I3
D3211	H2	Q3201	I4
D3212	I5	Q3202	I4
D3213	I5	Q3203	I3
D3214	I6		

**VIDEO (3) P.C.B. (Side A)**

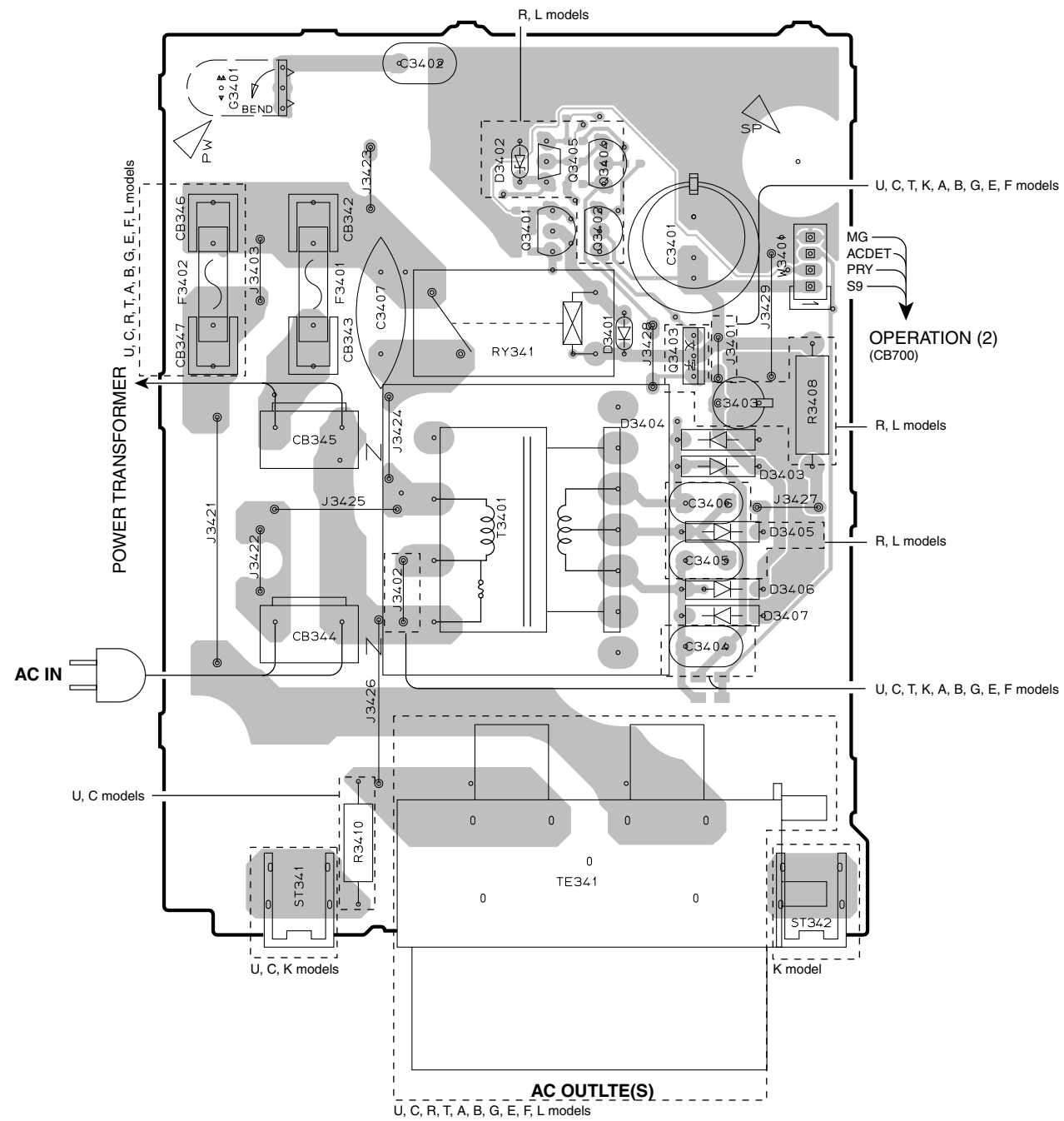

**VIDEO (3) P.C.B. (Side B)**

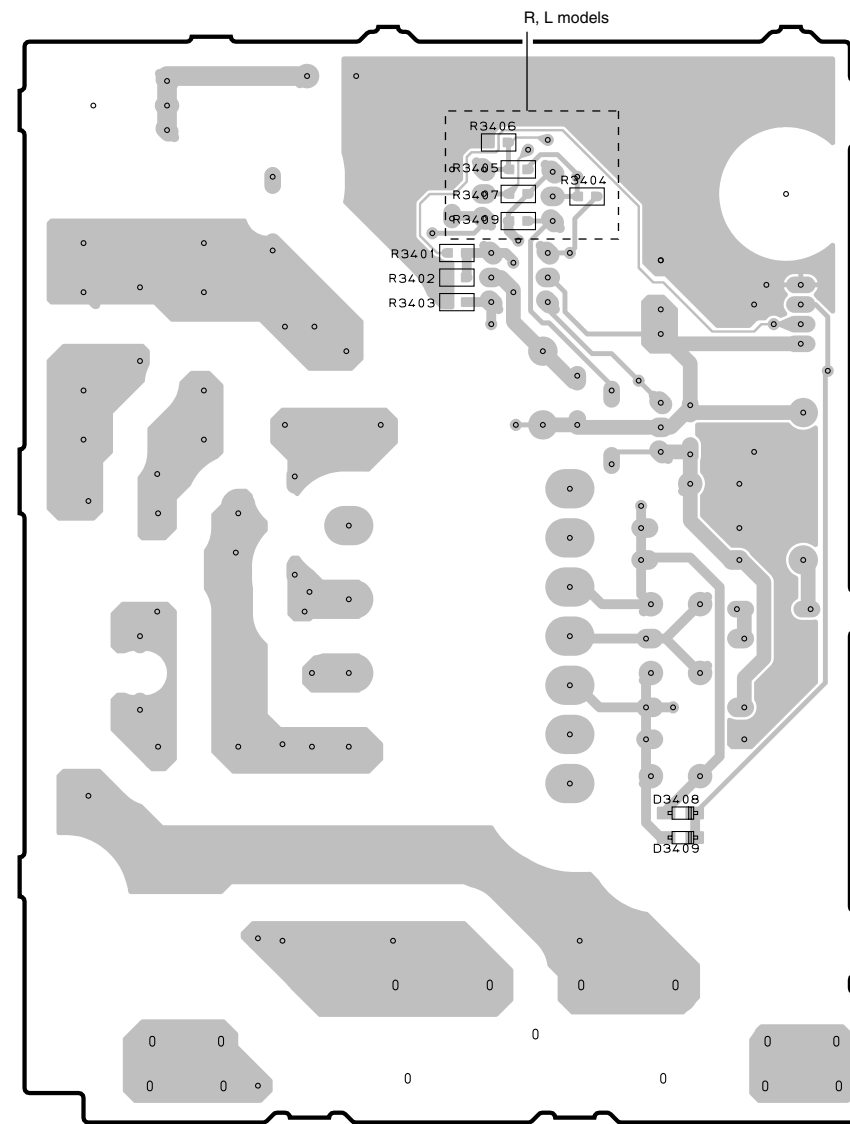

• **Semiconductor Location**

Ref no.	Location	Ref no.	Location
D3401	D3	D3408	H5
D3402	C2	D3409	H5
D3403	D4	Q3401	C3
D3404	D4	Q3402	D3
D3405	D4	Q3403	D3
D3406	D4	Q3404	D2
D3407	D4	Q3405	C2

VIDEO (4) P.C.B. (Side A)

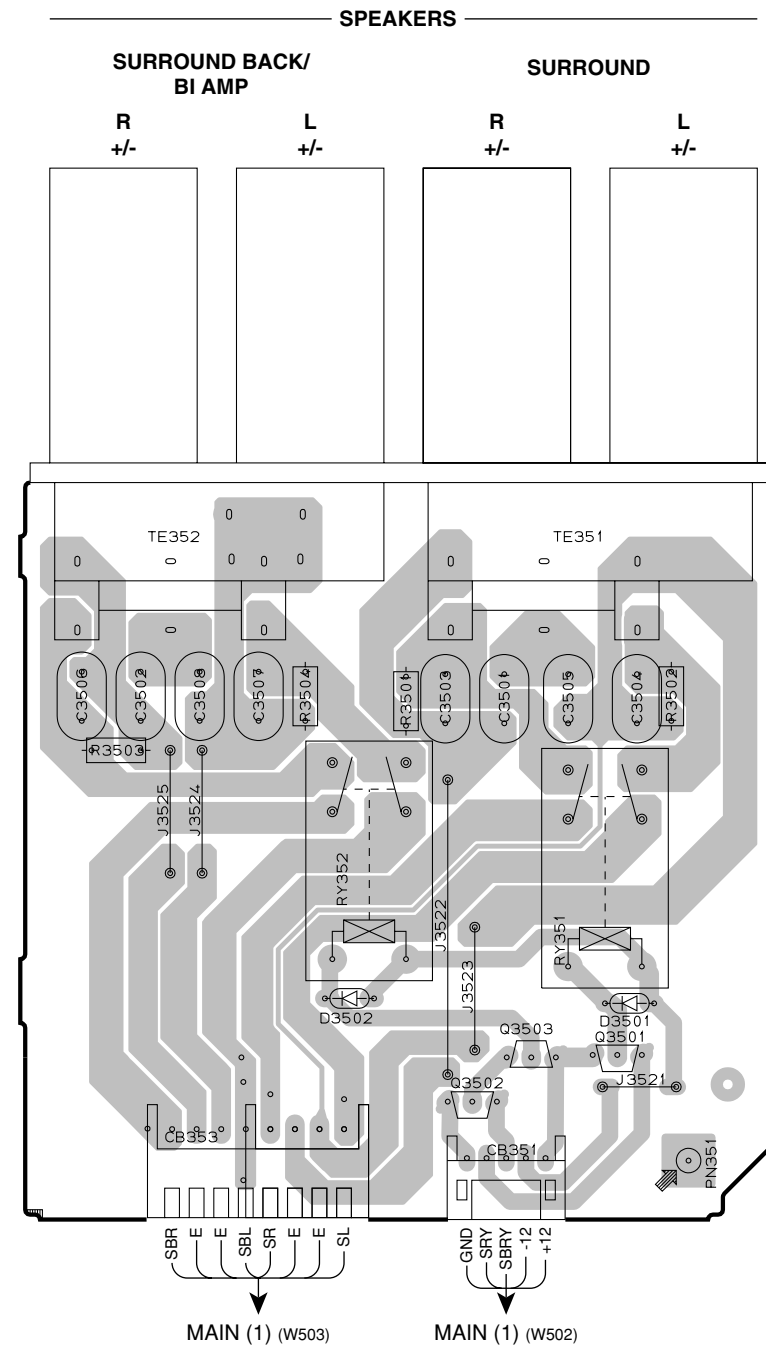

• Semiconductor Location

Ref no.	Location
D3501	D5
D3502	C5
D3651	H5
D3652	I5
Q3501	D5
Q3502	C6
Q3503	C5

VIDEO (5) P.C.B. (Side A)

R, L models

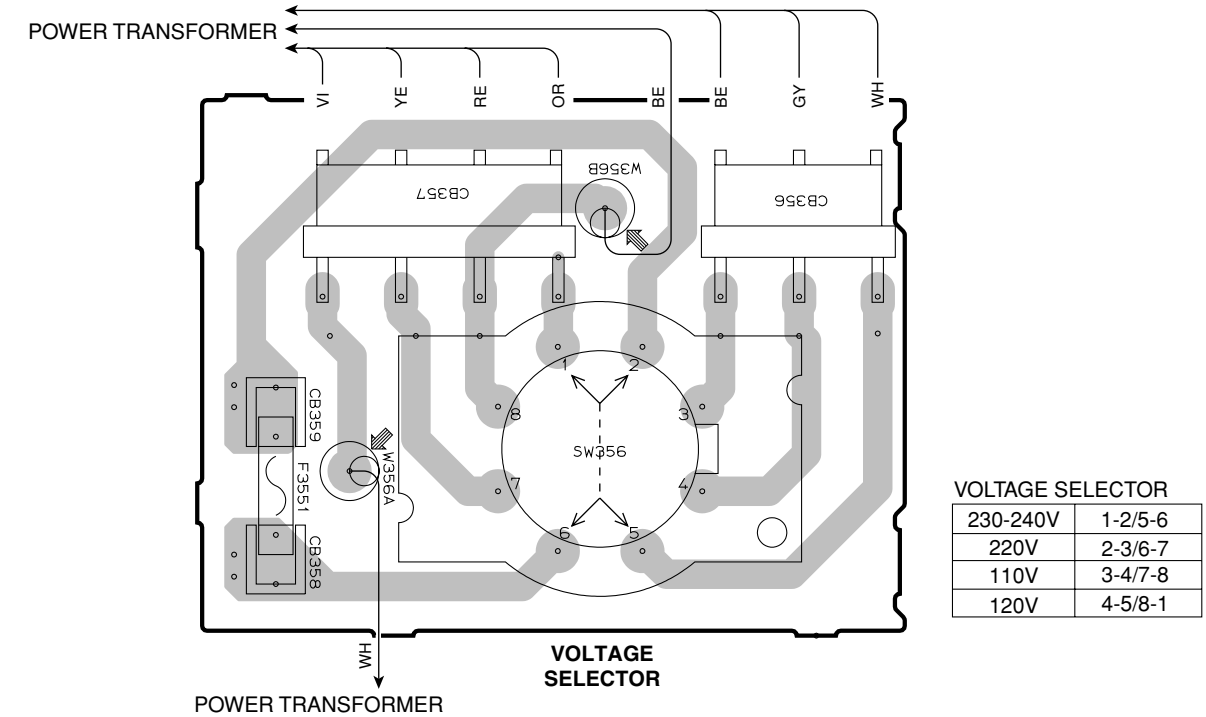

VOLTAGE SELECTOR

230-240V	1-2/5-6
220V	2-3/6-7
110V	3-4/7-8
120V	4-5/8-1

VIDEO (6) P.C.B. (Side A)

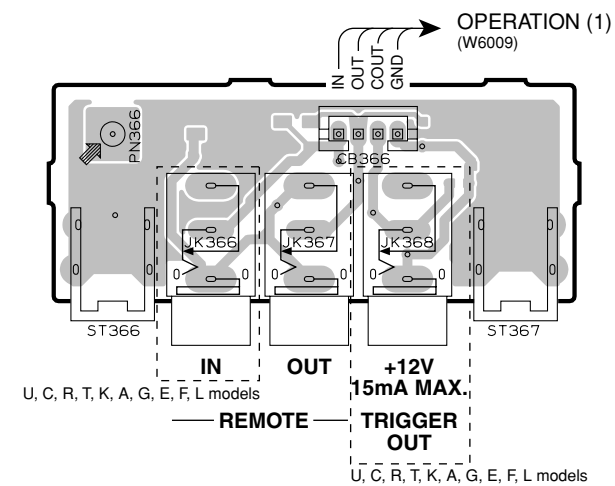

VIDEO (6) P.C.B. (Side B)

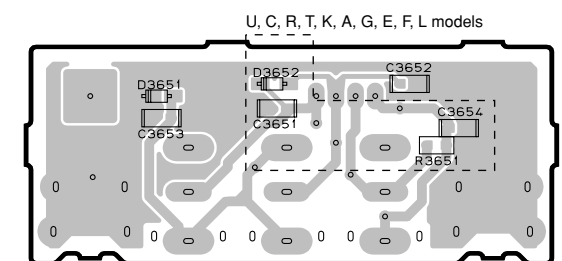

## ■ PIN CONNECTION DIAGRAMS

### ICs

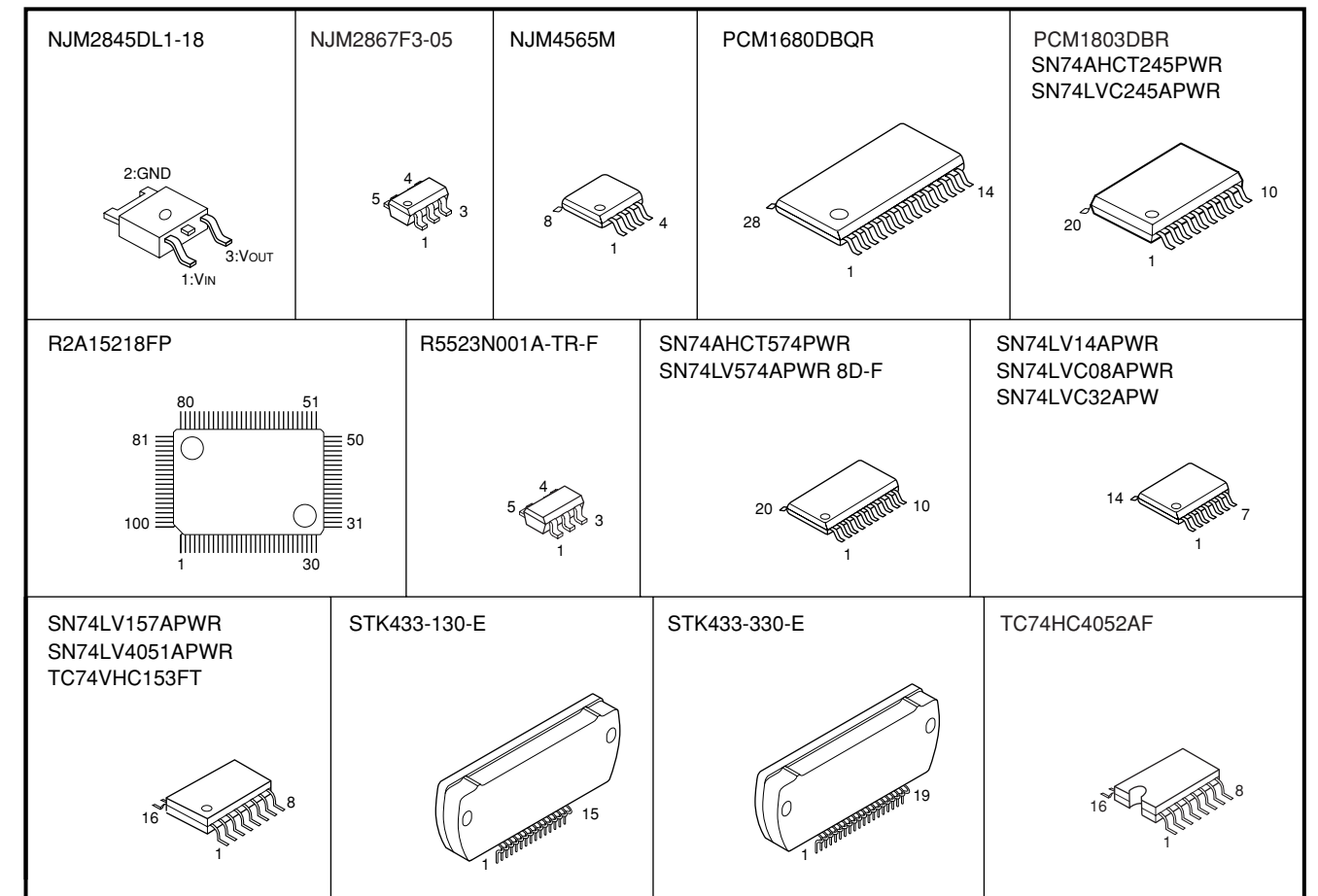
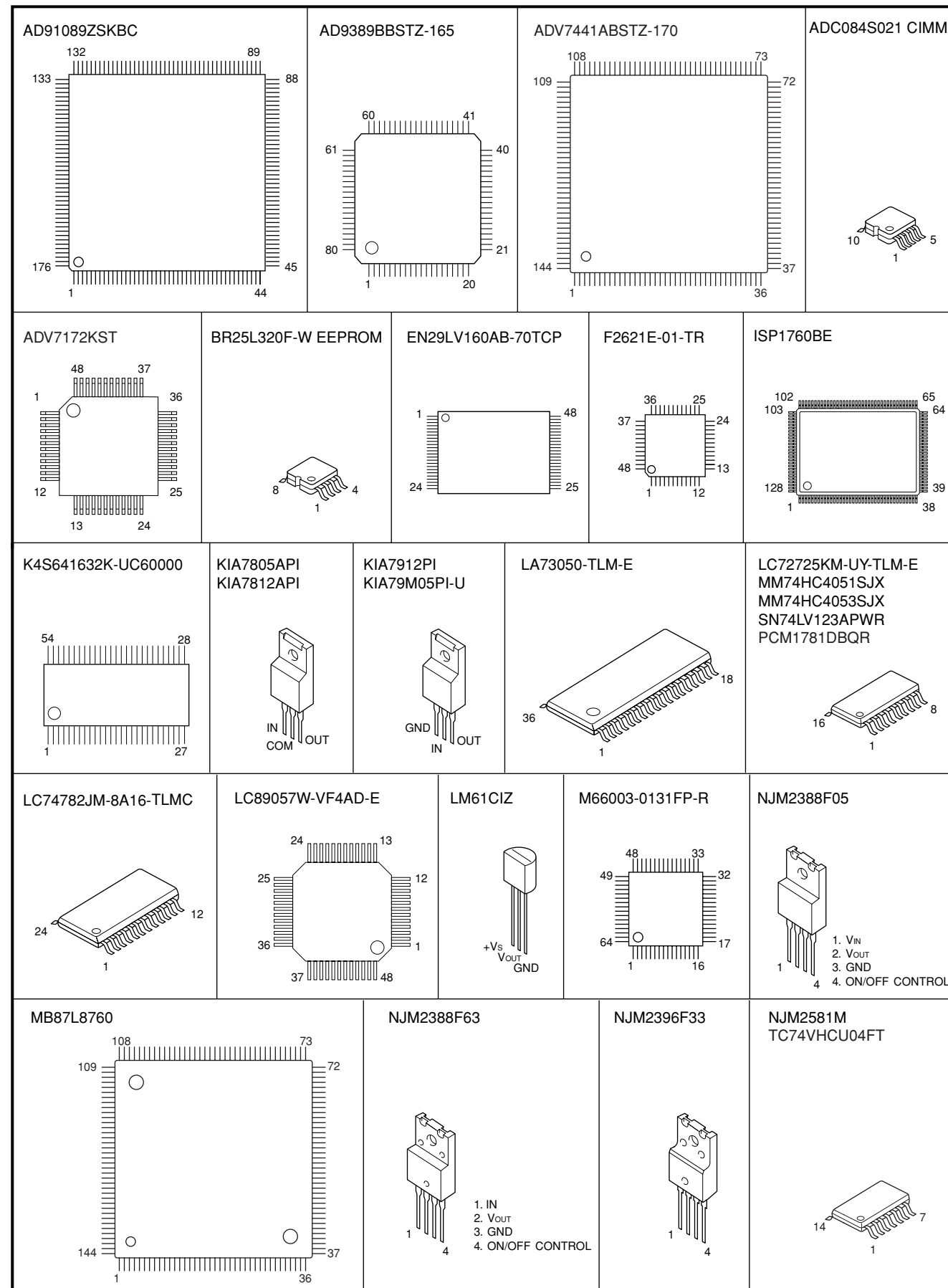



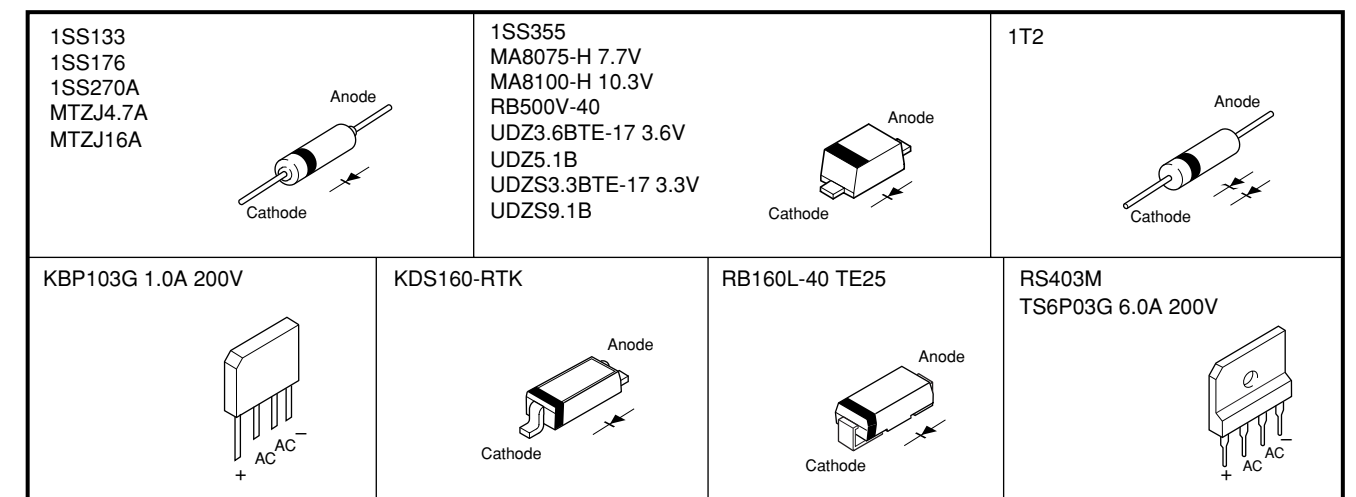

### Diodes



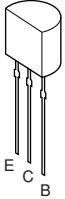
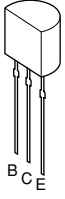

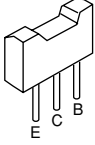
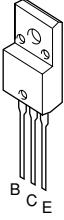
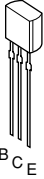
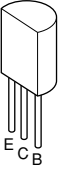
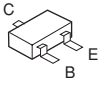
### Transistors

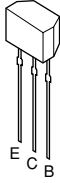
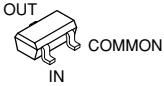
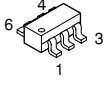
<p>2N5401C-AT/P 2SA1015-Y 2SC2705</p> 	<p>2N5551C-AT</p> 	<p>2SA1037K</p> 	<p>2SA1708</p> 	<p>2SB1274</p> 	<p>2SC1740S</p> 	<p>2SC1815 Y</p> 
<p>2SC2412K</p> 	<p>2SC3326-A (TE85R, F) 2SC3326-B (TE85R, F) 2SC4081 T106 2SD1938F</p> 	<p>DTA143EKA DTC114EKA</p>  <p>1: GND 2: IN 3: OUT</p>	<p>KRA102M-AT/P KRC102M-AT</p> 	<p>KRA102S-RTK/P KRA104S-RTK KRC102S-RTK KRC104S-RTK</p> 	<p>RTQ040P02</p>  <p>1. Drain 2. Drain 3. Gate 4. Source 5. Drain 6. Drain</p>	

MEMO



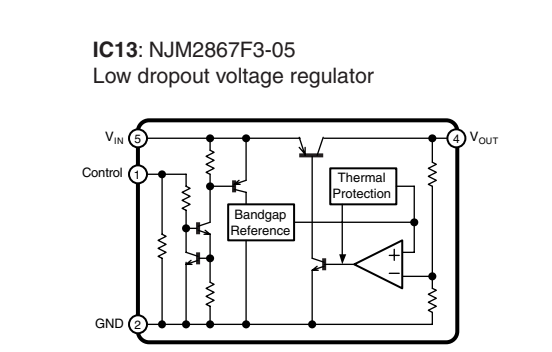
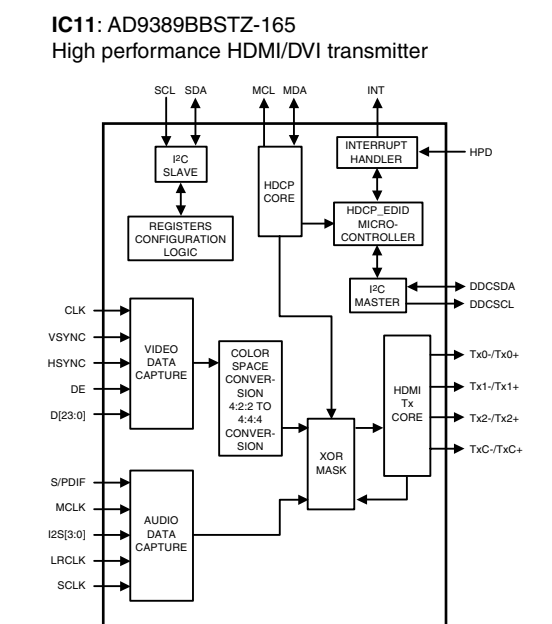
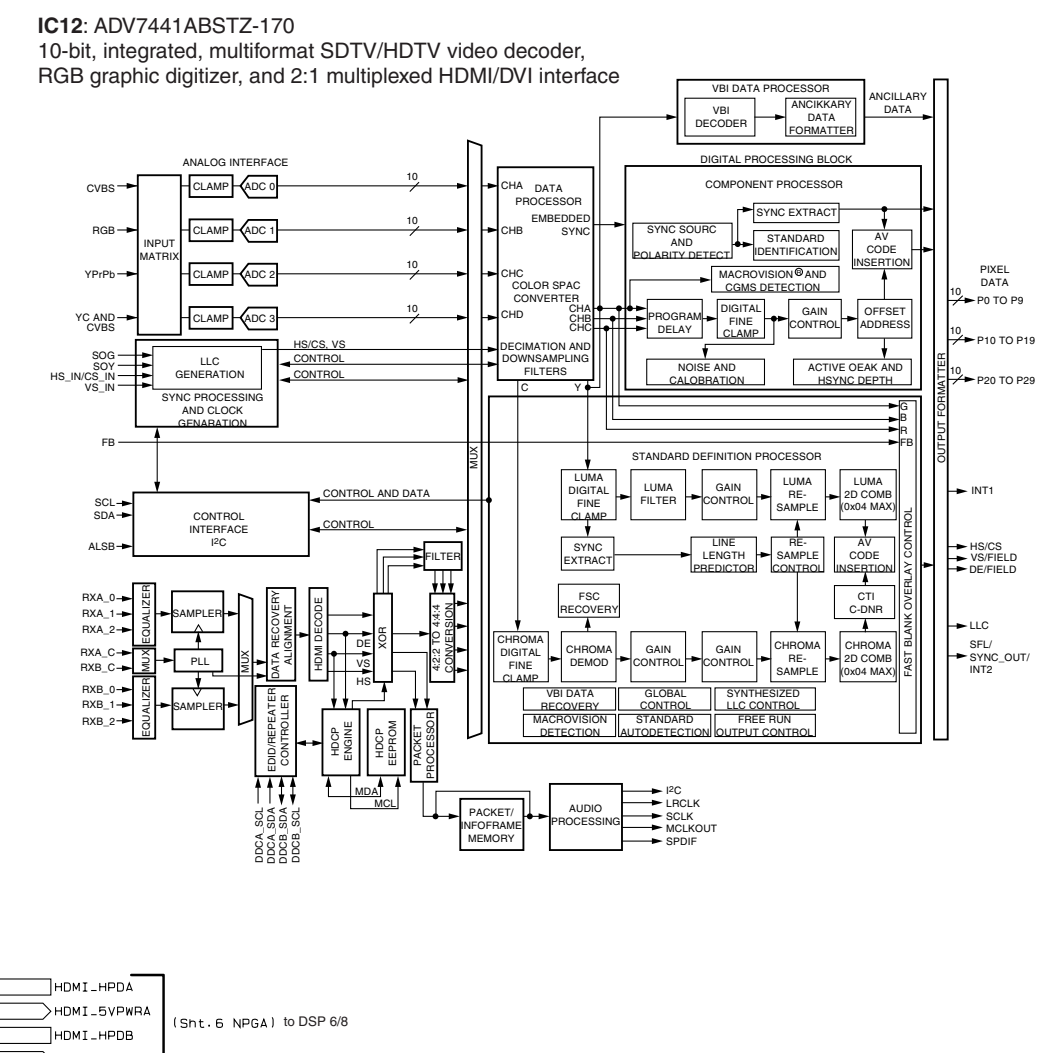
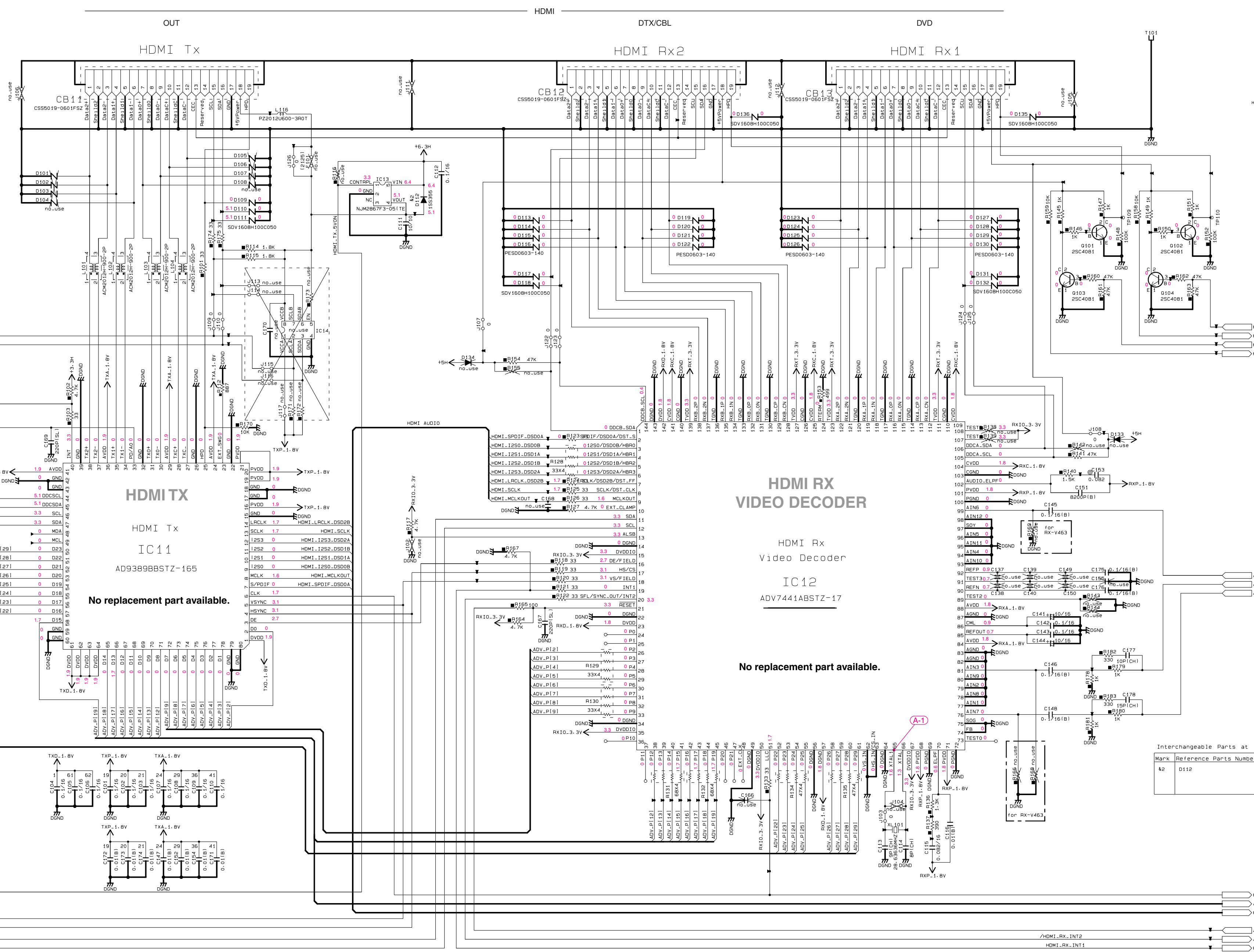

Interchangeable Parts at Manufacture-Stage

Mark	Reference Parts Number	Parts Name
42	D152	155395
		MA2J1100L

RESISTOR

REMARKS	PARTS_NAME
NO MARK	CARBON FILM RESISTOR (P=5)
☑	CARBON FILM RESISTOR (P=10)
△	METAL OXIDE FILM RESISTOR
▴	METAL FILM RESISTOR
□	METAL PLATE RESISTOR
▾	FIRE PROOF CARBON FILM RESISTOR
▢	CEMENT MOLDED RESISTOR
⊖	SEMI VARIABLE RESISTOR
■	CHIP RESISTOR

CAPACITOR

REMARKS	PARTS_NAME
NO MARK	ELECTROLYTIC CAPACITOR
⊗	TANTALUM CAPACITOR
●	CERAMIC CAPACITOR
⊙	POLYESTER FILM CAPACITOR
⊚	POLYSTYRENE FILM CAPACITOR
⊕	MICA CAPACITOR
⊖	POLYPROPYLENE FILM CAPACITOR
⊙	SEMICONDUCTIVE CERAMIC CAPACITOR

NOTICE (mode11)

(J)..... JAPAN  
(U)..... U.S.A  
(C)..... CANADA  
(R)..... GENERAL  
(T)..... CHINA  
(K)..... KOREA  
(A)..... AUSTRALIA  
(B)..... BRITISH  
(G)..... EUROPE  
(L)..... SINGAPORE  
(E)..... SOUTH EUROPE  
(V)..... TAIWAN  
(F)..... RUSSIAN

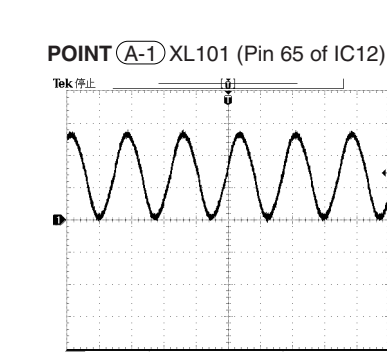

\* All voltages are measured with a 10MΩ/V DC electronic voltmeter.  
\* Components having special characteristics are marked !, and must be replaced with parts having specifications equal to those originally installed.  
\* Schematic diagram is subject to change without notice.

DSP 2/8

	RX-V563	RX-V463
J216	mount	no mount
J217	no mount	mount

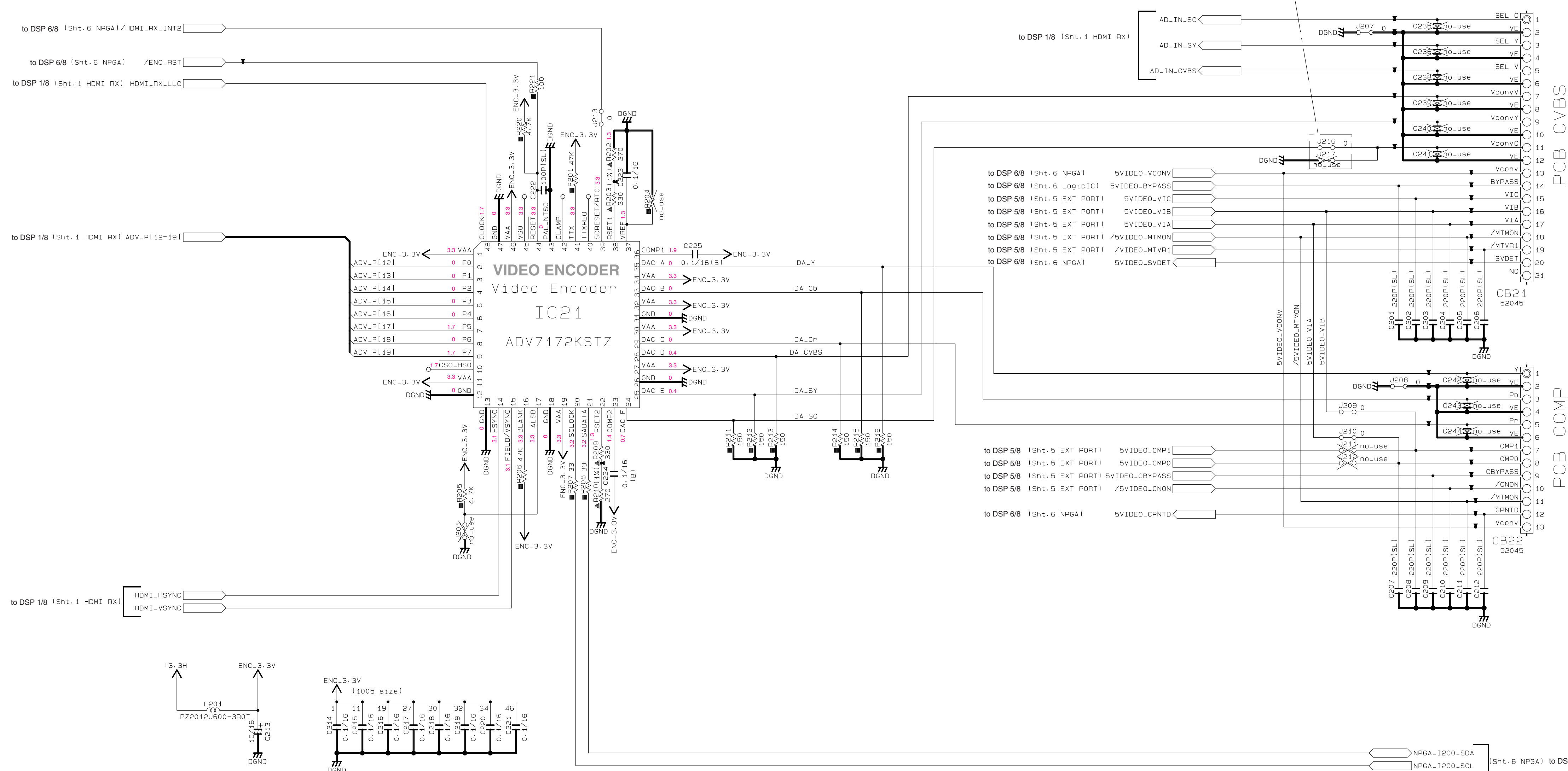

PCB CVBS

PCB COMP

Page 95 [K4]  
to VIDEO (1)\_CB303

Page 96 [D1]  
to VIDEO (2)\_CB326

Interchangeable Parts at Manufacture-Stage

Mark	Reference Parts Number	Parts Name
k2	D201	1SS355
		MA2J1110GL

RESISTOR

REMARKS	PARTS NAME
NO MARK	CARBON FILM RESISTOR (P=5)
□	CARBON FILM RESISTOR (P=10)
△	METAL OXIDE FILM RESISTOR
⊗	METAL FILM RESISTOR
⊙	METAL PLATE RESISTOR
⊚	FIRE PROOF CARBON FILM RESISTOR
⊛	CEMENT MOLDED RESISTOR
⊜	SEMI VARIABLE RESISTOR
⊝	CHIP RESISTOR

CAPACITOR

REMARKS	PARTS NAME
NO MARK	ELECTROLYTIC CAPACITOR
⊗	TANTALUM CAPACITOR
NO MARK	CERAMIC CAPACITOR
⊙	CERAMIC TUBULAR CAPACITOR
⊚	POLYESTER FILM CAPACITOR
⊛	POLYSTYRENE FILM CAPACITOR
⊜	MICA CAPACITOR
⊝	POLYPROPYLENE FILM CAPACITOR
⊞	SEMICONDUCTIVE CERAMIC CAPACITOR

NOTICE [mode1]

- (J)..... JAPAN
- (U)..... U.S.A
- (C)..... CANADA
- (R)..... GENERAL
- (T)..... CHINA
- (K)..... KOREA
- (A)..... AUSTRALIA
- (B)..... BRITISH
- (G)..... EUROPE
- (L)..... SINGAPORE
- (E)..... SOUTH EUROPE
- (V)..... TAIWAN
- (F)..... RUSSIAN

IC21: ADV7172KSTZ  
Digital PAL/NTSC video encoder

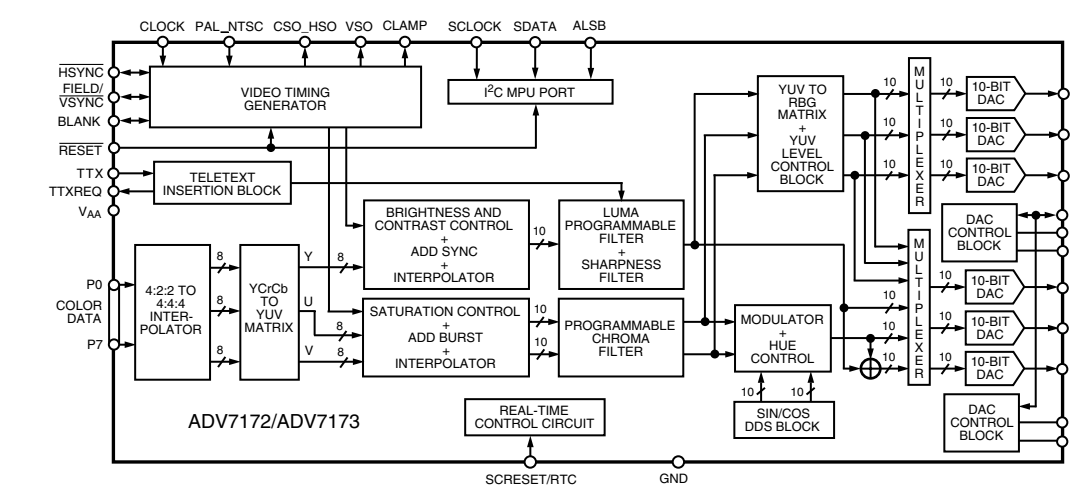

IC22: NJM2845DL1-18  
Low dropout voltage regulator

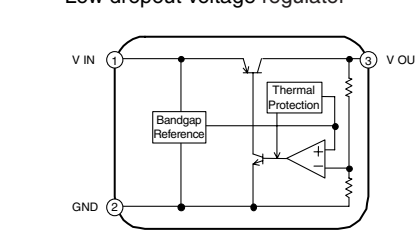

\* All voltages are measured with a 10MΩ/V DC electronic voltmeter.  
\* Components having special characteristics are marked ⚡, and must be replaced with parts having specifications equal to those originally installed.  
\* Schematic diagram is subject to change without notice.

DSP 3/8

REMARKS	PARTS NAME	REMARKS	PARTS NAME
NO MARK	CARBON FILM RESISTOR (P-5)	NO MARK	ELECTROLYTIC CAPACITOR
□	METAL OXIDE FILM RESISTOR (P-10)	⊗	TANTALUM CAPACITOR
△	METAL FILM RESISTOR	⊙	CERAMIC TUBULAR CAPACITOR
▴	METAL PLATE RESISTOR	⊖	POLYESTER FILM CAPACITOR
▾	FIRE PROOF CARBON FILM RESISTOR	⊕	POLYSTYRENE FILM CAPACITOR
⊖	CEMENT MOLDED RESISTOR	Ⓞ	MICA CAPACITOR
⊕	SEMI-VARIABLE RESISTOR	⊗	POLYPROPYLENE FILM CAPACITOR
■	CHIP RESISTOR	⊙	SEMICONDUCTIVE CERAMIC CAPACITOR

NOTICE (model1)  
 (J)..... JAPAN  
 (U)..... U.S.A  
 (C)..... CANADA  
 (R)..... GENERAL  
 (T)..... CHINA  
 (K)..... KOREA  
 (A)..... AUSTRALIA  
 (B)..... BRITISH  
 (G)..... EUROPE  
 (L)..... SINGAPORE  
 (E)..... SOUTH EUROPE  
 (V)..... TAIWAN  
 (F)..... RUSSIAN

No replacement part available.

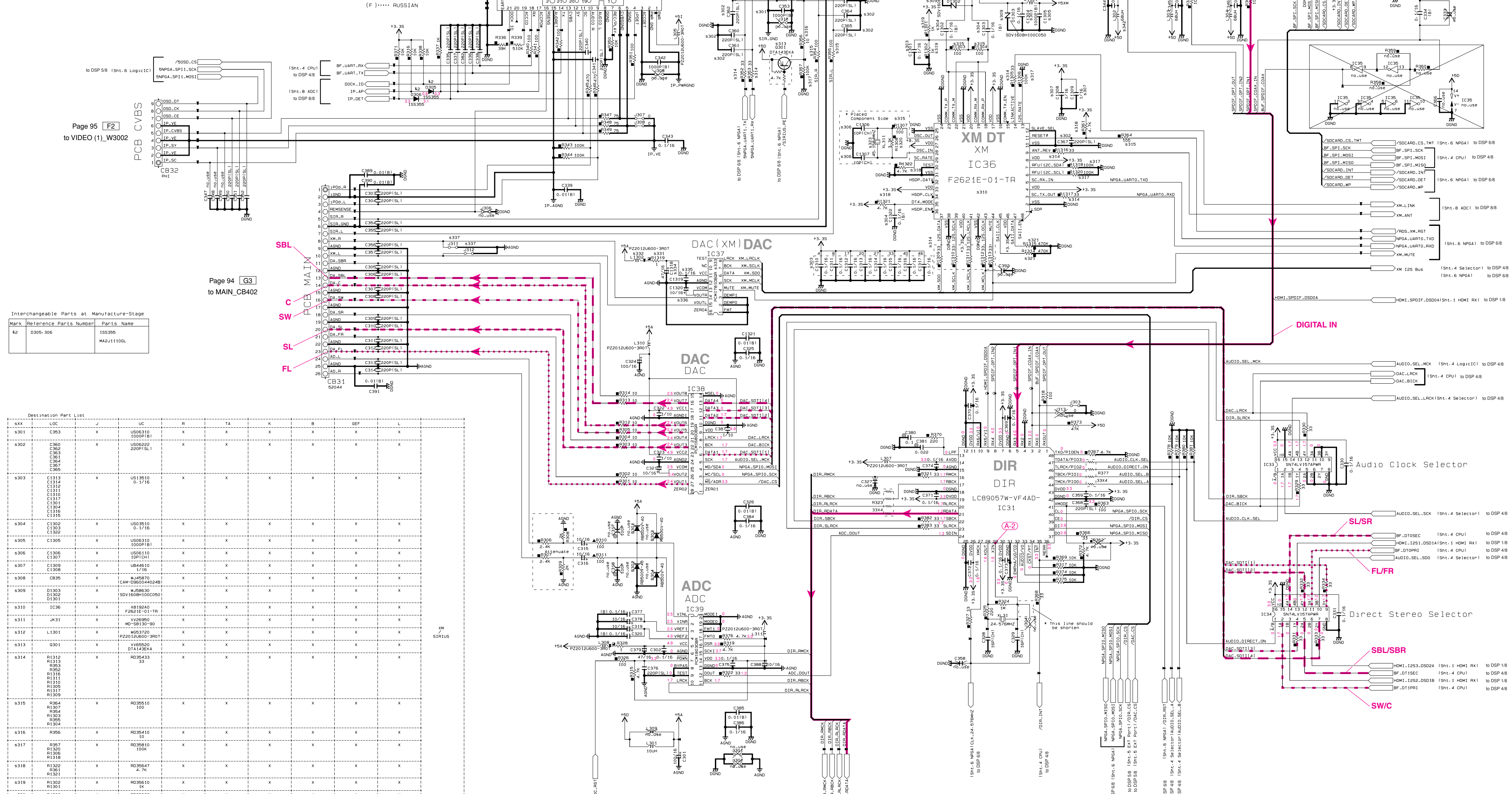

Interchangeable Parts at Manufacture-Stage

Mark	Reference Parts Number	Parts Name
82	D305-306	MAJ11100L

Destination Part List	LOC	QTY	UC	R	TA	X	B	DEF	L
8301	C353	X	US06330 1000P181	X	X	X	X	X	X
8302	C362	X	US06309 200P1511	X	X	X	X	X	X
8303	C1313	X	US13910 0.1F16	X	X	X	X	X	X
8304	C1303	X	US03910 0.1F16	X	X	X	X	X	X
8305	C1309	X	US06309 100P181	X	X	X	X	X	X
8306	C1307	X	US06309 100P181	X	X	X	X	X	X
8307	C1309	X	US06309 100P181	X	X	X	X	X	X
8308	C355	X	W45870 CAM-D0600440248	X	X	X	X	X	X
8309	C1309	X	US06309 100P181	X	X	X	X	X	X
8310	C355	X	W45870 CAM-D0600440248	X	X	X	X	X	X
8311	JK31	X	F2621E-01-TR	X	X	X	X	X	X
8312	L1301	X	WD37370 P220120600-3901	X	X	X	X	X	X
8313	G301	X	DT14384 33	X	X	X	X	X	X
8314	R1313	X	RD35493 33	X	X	X	X	X	X
8315	R1307	X	RD35493 33	X	X	X	X	X	X
8316	R1304	X	RD35493 33	X	X	X	X	X	X
8317	R1300	X	RD35493 100K	X	X	X	X	X	X
8318	R1301	X	RD35493 4.7K	X	X	X	X	X	X
8319	R1302	X	RD35493 1K	X	X	X	X	X	X
8320	R1308	X	RD35493 3.3K	X	X	X	X	X	X
8321	R1315	X	RD35493 X	X	X	X	X	X	X
8322	S131	X	W566800	X	X	X	X	X	X
8323	X1311	X	W45870 46.1584MHz	X	X	X	X	X	X
8331	R1319	X	HY76310	X	X	X	X	X	X
8332	L1302	X	WD37370 P220120600-3901	X	X	X	X	X	X
8333	IC37	X	Y73730 PCM1781DBQR	X	X	X	X	X	X
8334	C1318	X	US13910 47F16	X	X	X	X	X	X
8335	C1319	X	US13910 0.1F16	X	X	X	X	X	X
8336	C1320	X	US03910 10F16	X	X	X	X	X	X
8337	J311	X	RD35493 0	X	X	X	X	X	X
8341	C344	X	US13910 0.1F16	X	X	X	X	X	X
8342	L302	X	W452570 X	X	X	X	X	X	X
8343	U31	X	W452570 GP1FV51TK0F	X	X	X	X	X	X

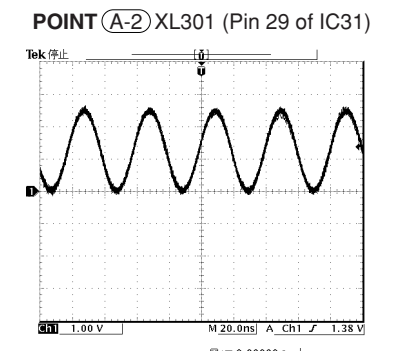
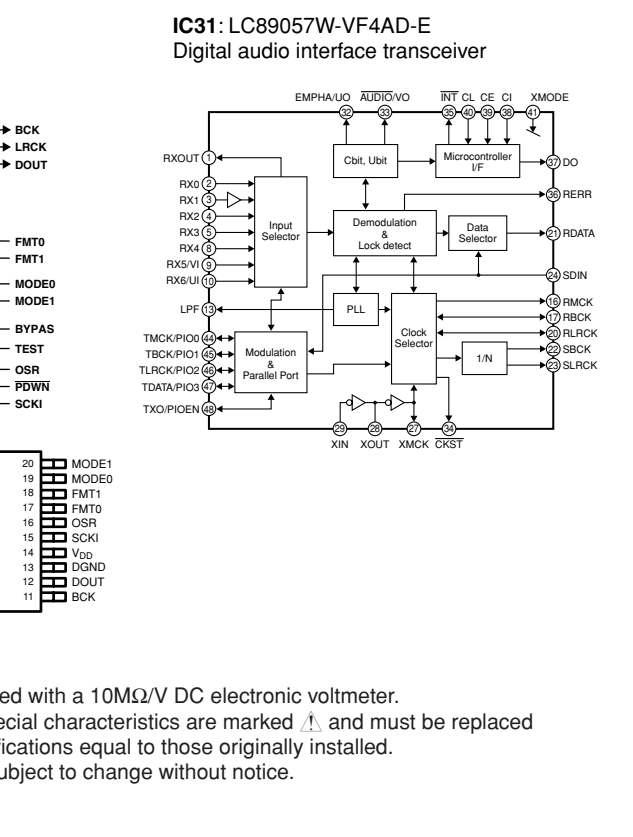
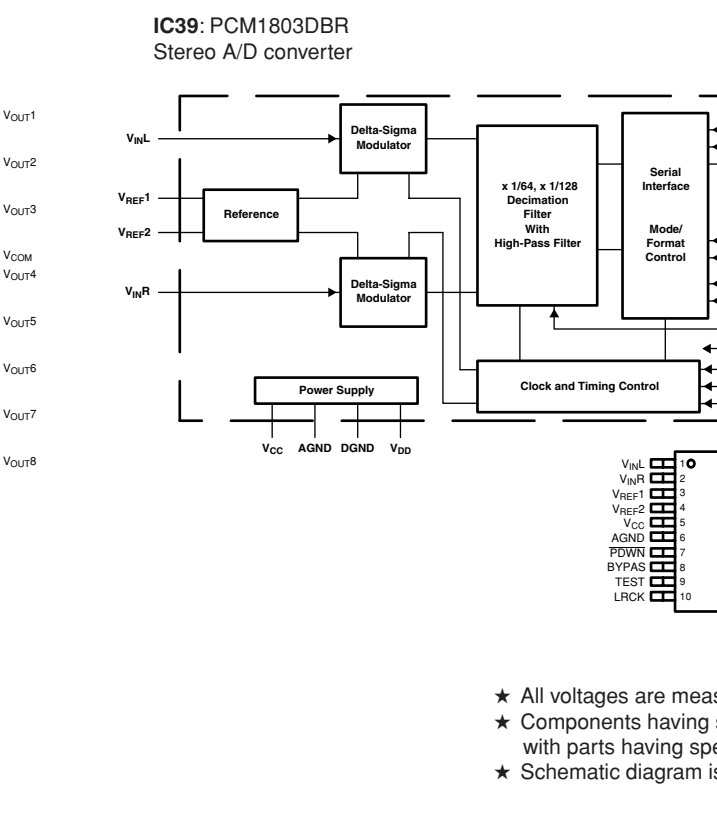
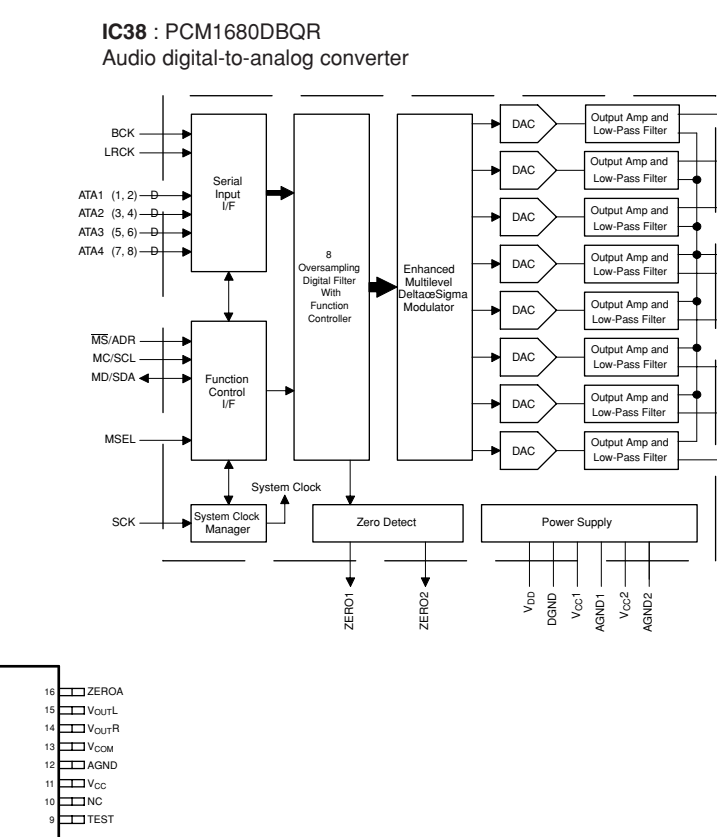
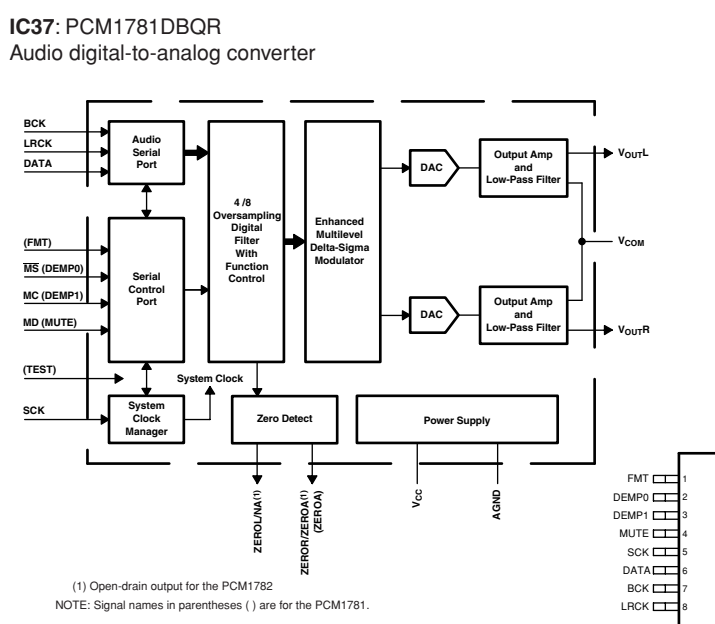
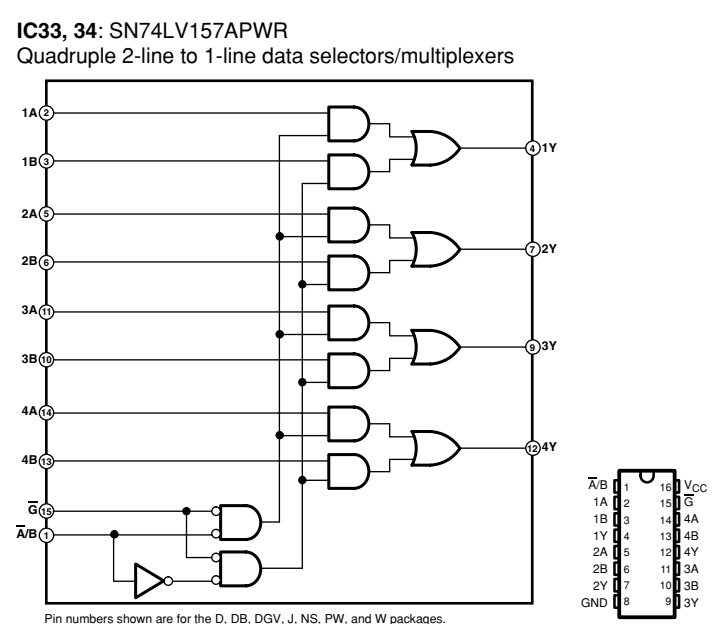

\* All voltages are measured with a 10MΩ/V DC electronic voltmeter.  
 \* Components having special characteristics are marked !, and must be replaced with parts having specifications equal to those originally installed.  
 \* Schematic diagram is subject to change without notice.

DSP 4/8

Part No.	LOC	J	UC	R	TA	K	B	GEF	L	XM
s401	J404	R03000	X	R03000	R03000	R03000	R03000	R03000	R03000	XM
s402	R408	X	X	R03043	R03043	R03043	R03043	R03043	R03043	USB

REMARKS	PARTS NAME
NO MARK	CARBON FILM RESISTOR [P=5]
NO MARK	CARBON FILM RESISTOR [P=10]
NO MARK	METAL OXIDE FILM RESISTOR
NO MARK	METAL FILM RESISTOR
NO MARK	METAL PLATE RESISTOR
NO MARK	FINE PROOF CARBON FILM RESISTOR
NO MARK	CEMENT MOLDED RESISTOR
NO MARK	SEMI VARIABLE RESISTOR
NO MARK	CHIP RESISTOR

REMARKS	PARTS NAME
NO MARK	ELECTROLYTIC CAPACITOR
NO MARK	TANTALUM CAPACITOR
NO MARK	CERAMIC CAPACITOR
NO MARK	CERAMIC TUBULAR CAPACITOR
NO MARK	POLYESTER FILM CAPACITOR
NO MARK	POLYETHYLENE FILM CAPACITOR
NO MARK	MICA CAPACITOR
NO MARK	POLYPROPYLENE FILM CAPACITOR
NO MARK	SEMICONDUCTIVE CERAMIC CAPACITOR

REMARKS	MODELS
(J).....	JAPAN
(U).....	U.S.A
(C).....	CANADA
(R).....	GENERAL
(T).....	CHINA
(K).....	KOREA
(A).....	AUSTRALIA
(B).....	BRITISH
(G).....	EUROPE
(L).....	SINGAPORE
(E).....	SOUTH EUROPE
(V).....	TAIWAN
(F).....	RUSSIAN

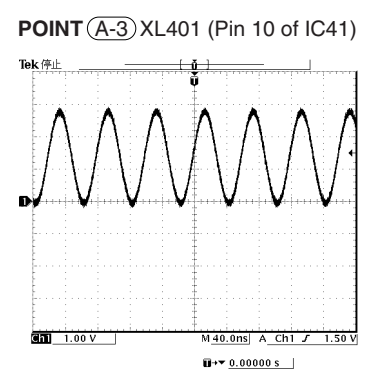
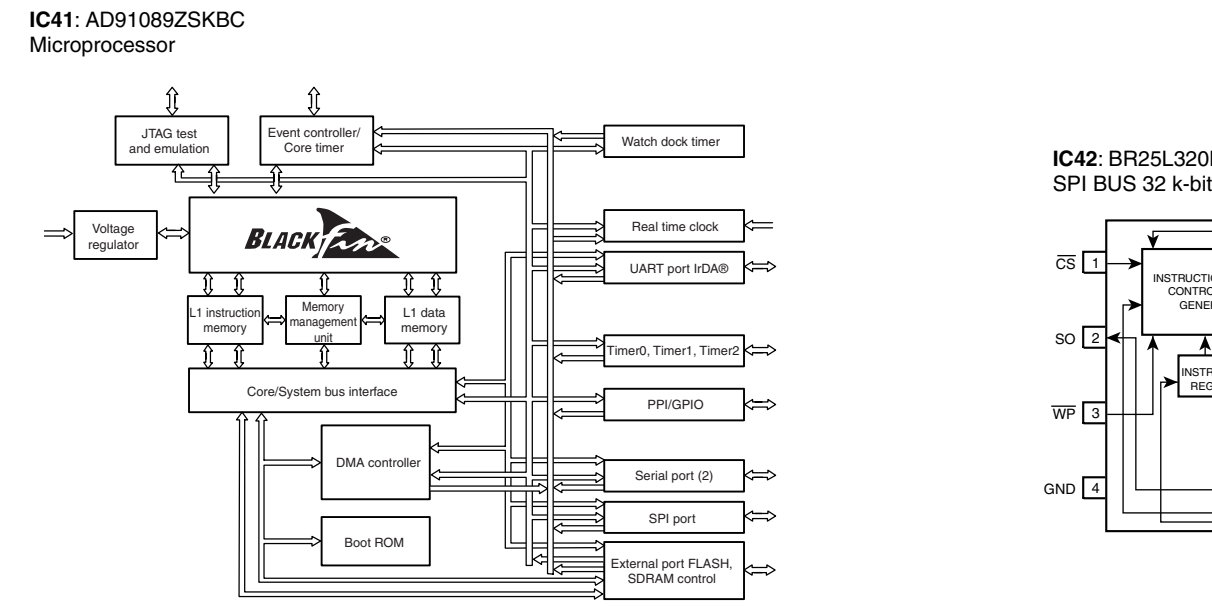
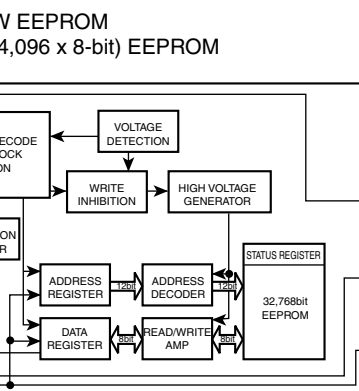
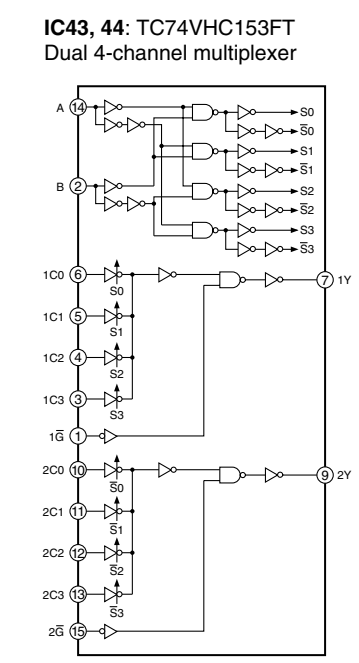
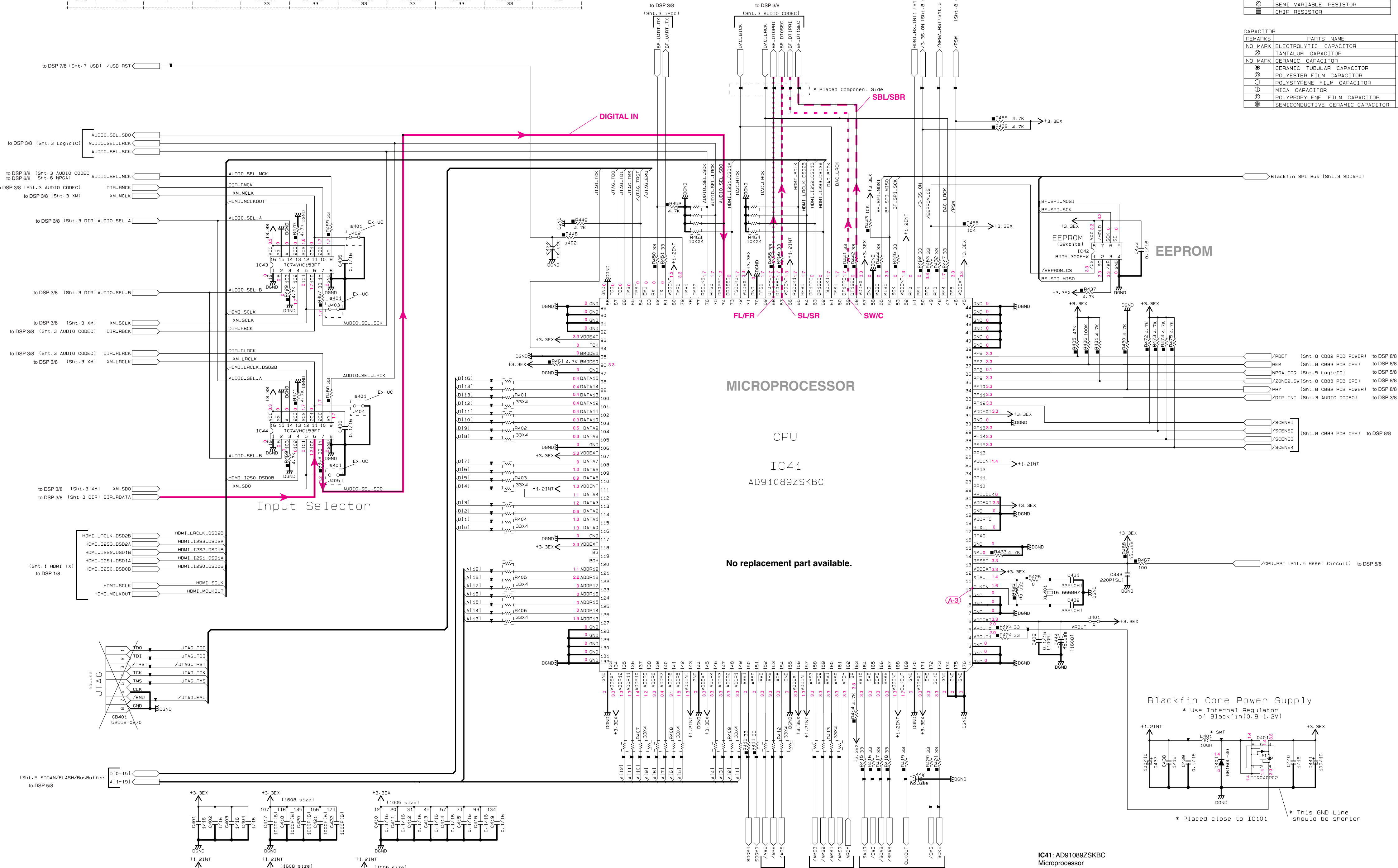

\* All voltages are measured with a 10MΩ/V DC electronic voltmeter.  
 \* Components having special characteristics are marked with a triangle and must be replaced with parts having specifications equal to those originally installed.  
 \* Schematic diagram is subject to change without notice.

DSP 5/8

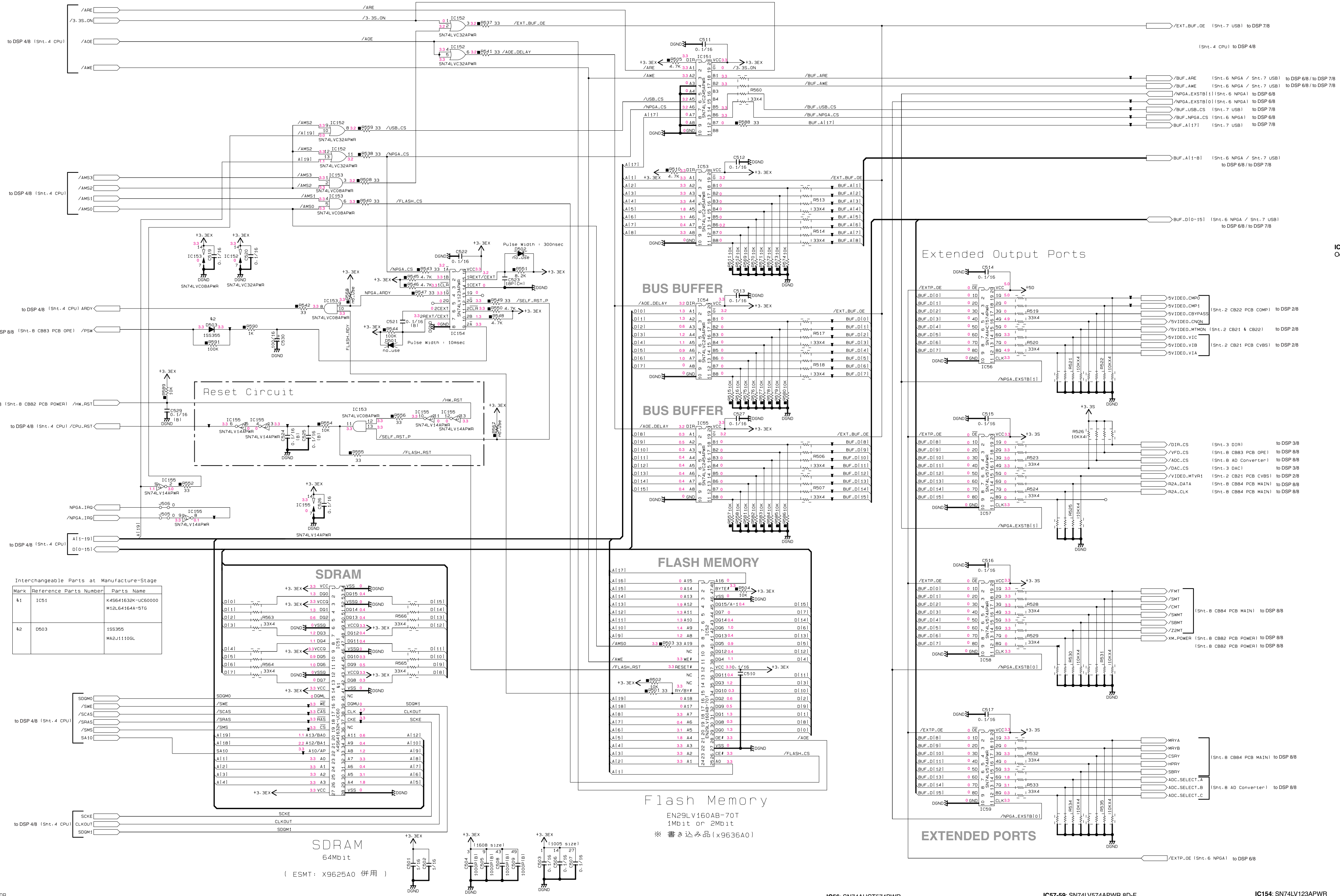

NOTICE (model)

(J)..... JAPAN  
 (U)..... U.S.A  
 (C)..... CANADA  
 (R)..... GENERAL  
 (T)..... CHINA  
 (K)..... KOREA  
 (A)..... AUSTRALIA  
 (B)..... BRITISH  
 (G)..... EUROPE  
 (L)..... SINGAPORE  
 (E)..... SOUTH EUROPE  
 (V)..... TAIWAN  
 (F)..... RUSSIAN

IC55-55: SN74V1423APWR  
 Octal bus transceivers with 3-state outputs

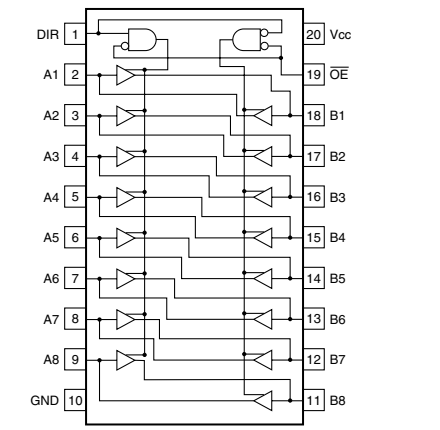

IC152: SN74V1423APWR  
 Quadrate 2-input positive-OR gates

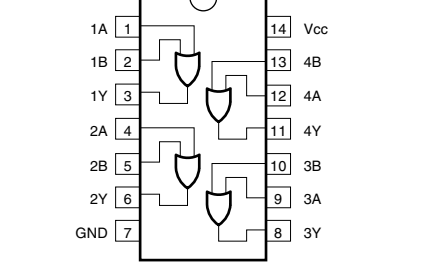

IC153: SN74V1423APWR  
 Quadrate 2-input positive-AND gate

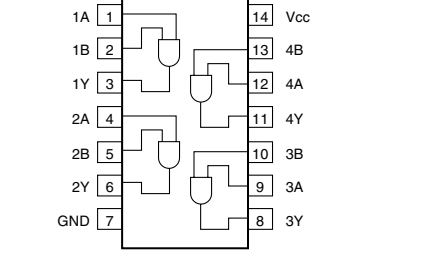

IC155: SN74V144PWR  
 Hex schmitt trigger inverters

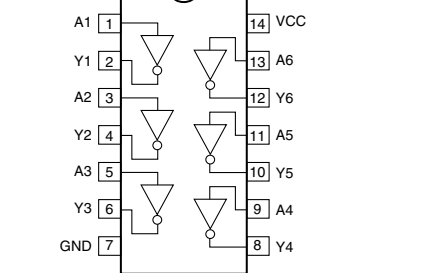

Interchangeable Parts at Manufacture-Stage

Mark	Reference Parts Number	Parts Name
k1	IC51	K4S641632K-UC60000 M12L64164A-5TG
k2	D603	1SS395 MA2J1100L

RESISTOR

REMARKS	PARTS NAME
NO MARK	CARBON FILM RESISTOR (P=5)
□	CARBON FILM RESISTOR (P=10)
△	METAL OXIDE FILM RESISTOR
▲	METAL FILM RESISTOR
○	METAL PLATE RESISTOR
◇	FINE PROOF CARBON FILM RESISTOR
■	CEMENT MOLDED RESISTOR
□	SEMI VARIABLE RESISTOR
■	CHIP RESISTOR

CAPACITOR

REMARKS	PARTS NAME
NO MARK	ELECTROLYTIC CAPACITOR
○	TANTALUM CAPACITOR
NO MARK	CERAMIC CAPACITOR
●	CERAMIC TUBULAR CAPACITOR
○	POLYESTER FILM CAPACITOR
○	POLYSTYRENE FILM CAPACITOR
○	MICA CAPACITOR
○	POLYPROPYLENE FILM CAPACITOR
○	SEMICONDUCTIVE CERAMIC CAPACITOR

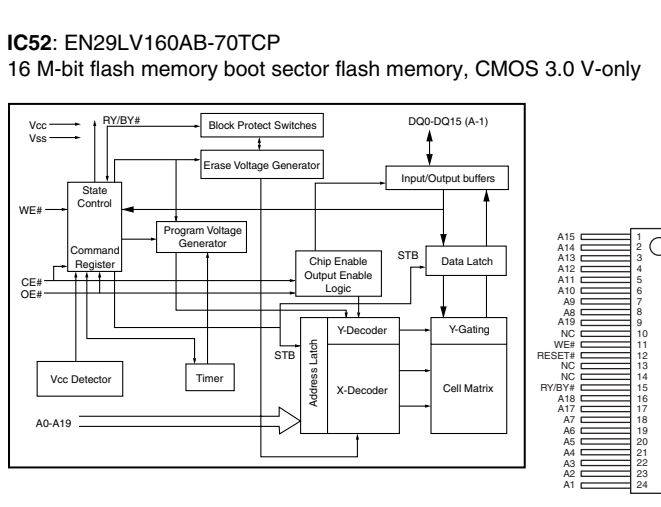
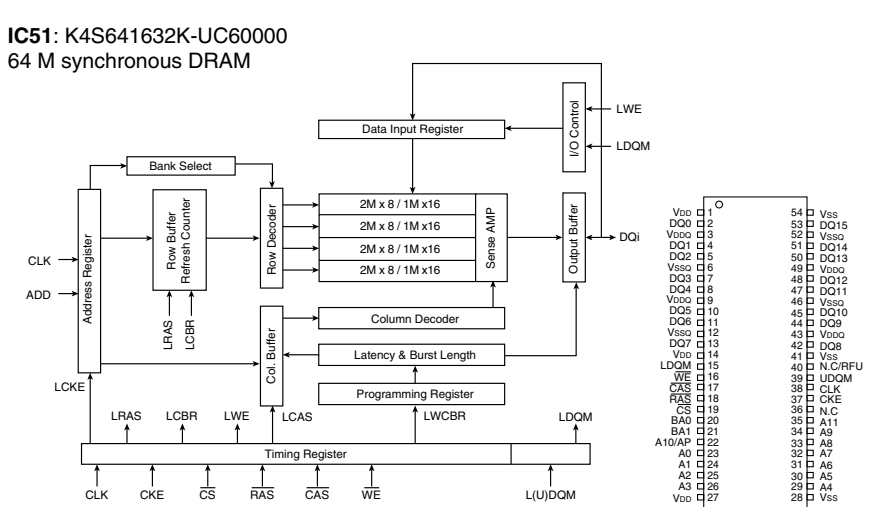

IC56: SN74AHC174PWR  
 Octal edge-triggered D-type flip-flops with 3-state outputs

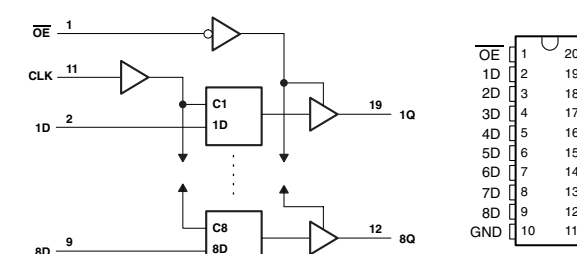

IC57-59: SN74LV574PWR 8D-F  
 Octal edge-triggered D-type flip-flops with 3-state outputs

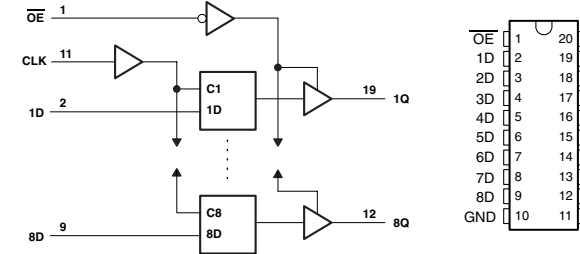

IC154: SN74LV123APWR  
 Dual retriggerable monostable multivibrators with schmitt-trigger inputs

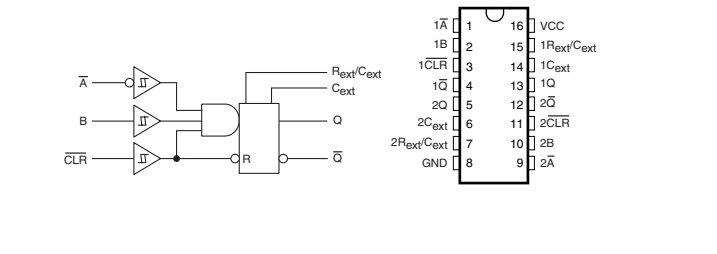

\* All voltages are measured with a 10MΩ/V DC electronic voltmeter.  
 \* Components having special characteristics are marked !, and must be replaced with parts having specifications equal to those originally installed.  
 \* Schematic diagram is subject to change without notice.

DSP 6/8

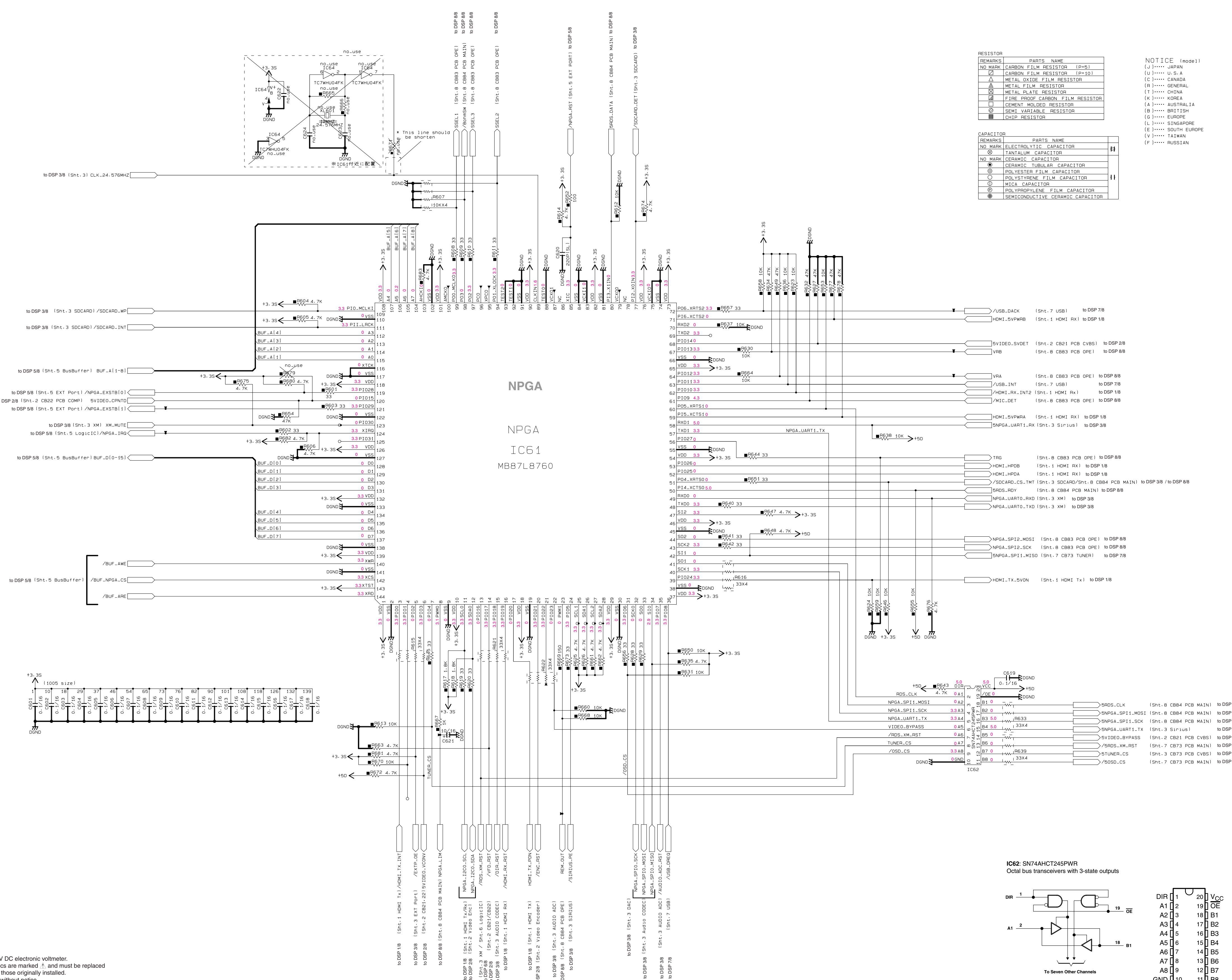

REMARKS	PARTS_NAME
NO MARK	CARBON FILM RESISTOR (P=5)
□	CARBON FILM RESISTOR (P=10)
△	METAL OXIDE FILM RESISTOR
▲	METAL FILM RESISTOR
⊠	METAL PLATE RESISTOR
■	FIRE PROOF CARBON FILM RESISTOR
□	CEMENT MOLDED RESISTOR
⊗	SMT VARIABLE RESISTOR
■	CHIP RESISTOR

REMARKS	PARTS_NAME
NO MARK	ELECTROLYTIC CAPACITOR
□	TANTALUM CAPACITOR
○	CERAMIC TUBULAR CAPACITOR
⊙	POLYESTER FILM CAPACITOR
○	POLYSTYRENE FILM CAPACITOR
○	MICA CAPACITOR
⊙	POLYPROPYLENE FILM CAPACITOR
⊙	SEMICONDUCTIVE CERAMIC CAPACITOR

NOTICE (model)

(J) ..... JAPAN  
 (U) ..... U.S.A  
 (C) ..... CANADA  
 (R) ..... GENERAL  
 (T) ..... CHINA  
 (K) ..... KOREA  
 (A) ..... AUSTRALIA  
 (B) ..... BRITISH  
 (G) ..... EUROPE  
 (L) ..... SINGAPORE  
 (E) ..... SOUTH EUROPE  
 (V) ..... TAIWAN  
 (F) ..... RUSSIAN

IC62: SN74AHCT245PWR  
Octal bus transceivers with 3-state outputs

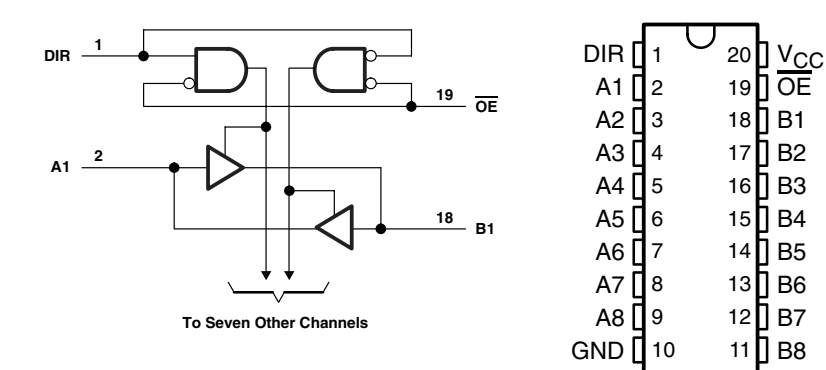

\* All voltages are measured with a 10MΩ/V DC electronic voltmeter.  
 \* Components having special characteristics are marked ▲, and must be replaced with parts having specifications equal to those originally installed.  
 \* Schematic diagram is subject to change without notice.



DSP 7/8

REMARKS	PARTS NAME
NO MARK	CARBON FILM RESISTOR (P=5)
□	CARBON FILM RESISTOR (P=10)
△	METAL OXIDE FILM RESISTOR
⊠	METAL FILM RESISTOR
⊡	METAL PLATE RESISTOR
⊞	FIRE PROOF CARBON FILM RESISTOR
⊞	CEMENT MOLDED RESISTOR
⊞	SEMI VARIABLE RESISTOR
⊞	CHIP RESISTOR

REMARKS	PARTS NAME
NO MARK	ELECTROLYTIC CAPACITOR
⊗	TANTALUM CAPACITOR
NO MARK	CERAMIC CAPACITOR
⊙	CERAMIC TUBULAR CAPACITOR
⊙	POLYESTER FILM CAPACITOR
⊙	POLYESTER FILM CAPACITOR
⊙	MICA CAPACITOR
⊙	POLYPROPYLENE FILM CAPACITOR
⊙	SEMICONDUCTIVE CERAMIC CAPACITOR

NOTICE (model)

(J)..... JAPAN  
 (U)..... U.S.A  
 (C)..... CANADA  
 (R)..... GENERAL  
 (T)..... CHINA  
 (K)..... KOREA  
 (A)..... AUSTRALIA  
 (B)..... BRITISH  
 (G)..... EUROPE  
 (L)..... SINGAPORE  
 (E)..... SOUTH EUROPE  
 (V)..... TAIWAN  
 (F)..... RUSSIAN

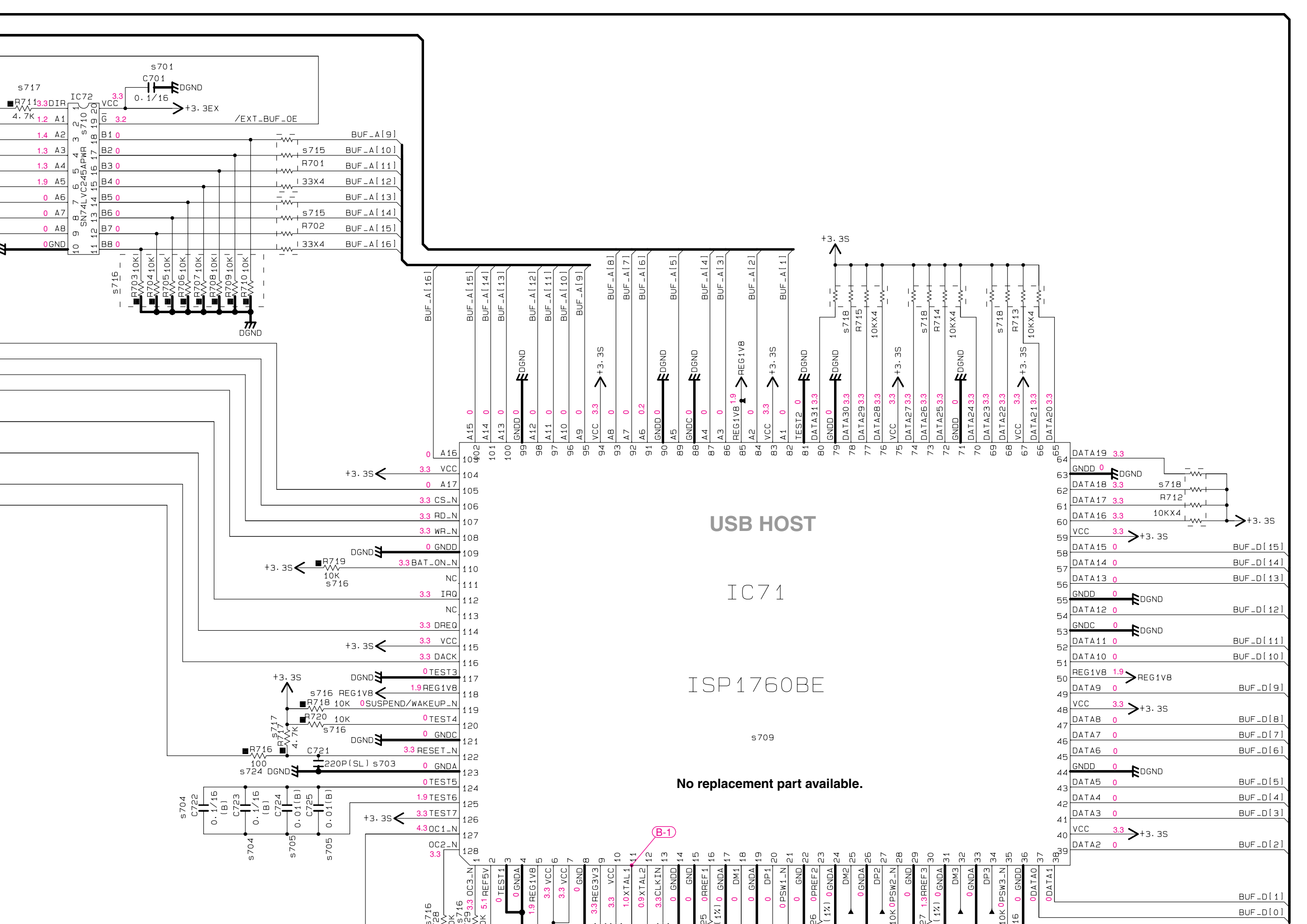
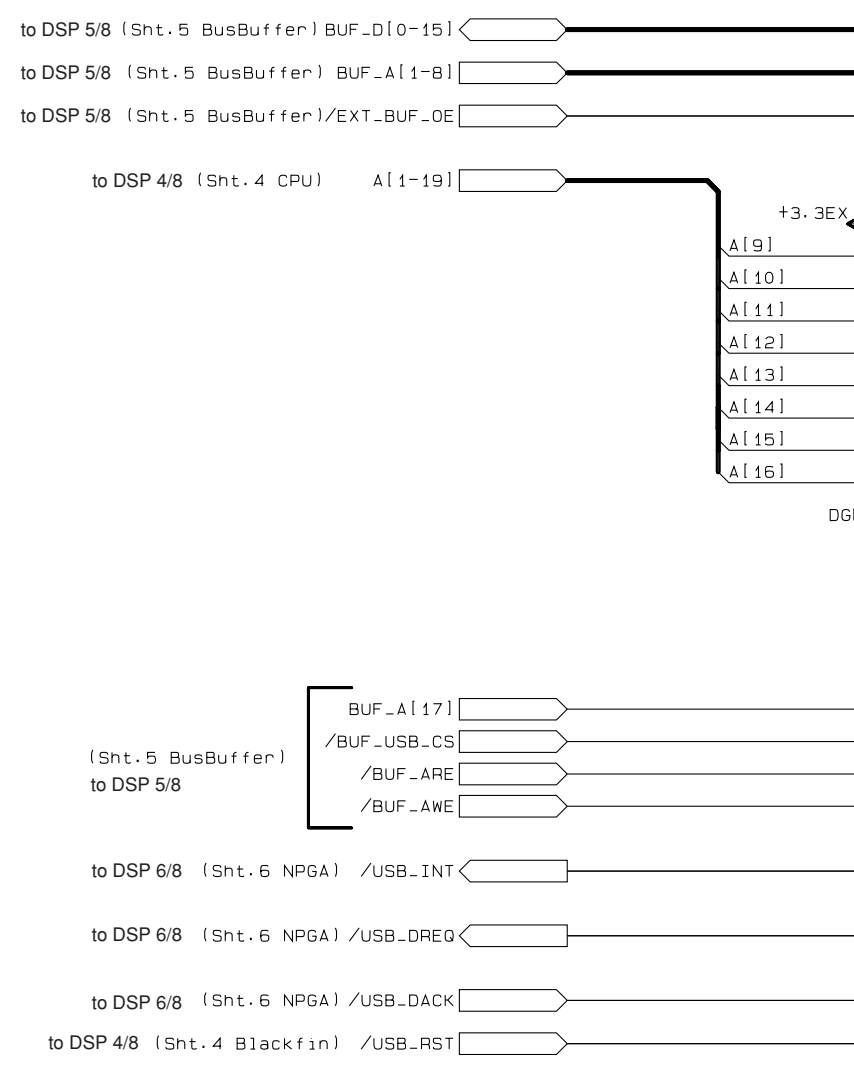
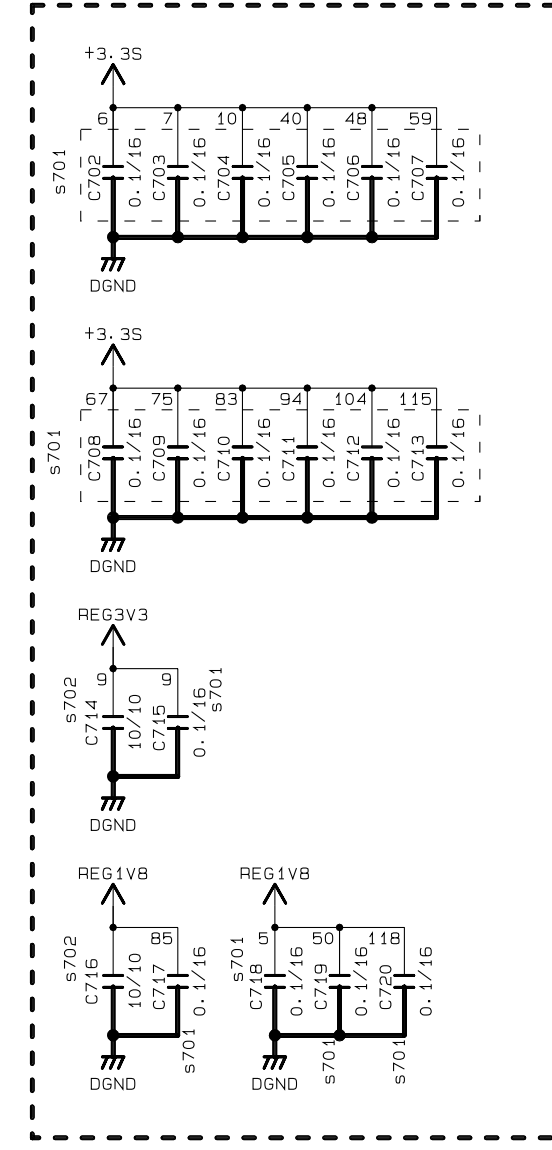

sxx	LOC	J	UC	R	TA	K	B	GEF	L
s701	C705	X	X	US13510	US13510	US13510	US13510	US13510	US13510
s702	C714	X	X	WD75830	WD75830	WD75830	WD75830	WD75830	WD75830
s703	C721	X	X	US06222	US06222	US06222	US06222	US06222	US06222
s704	C723	X	X	US03510	US03510	US03510	US03510	US03510	US03510
s705	C731	X	X	US06410	US06410	US06410	US06410	US06410	US06410
s706	C727	X	X	US06120	US06120	US06120	US06120	US06120	US06120
s707	C729	X	X	UR83810	UR83810	UR83810	UR83810	UR83810	UR83810
s708	C871	X	X	VB85850	VB85850	VB85850	VB85850	VB85850	VB85850
s709	IC71	X	X	XB288A0	XB288A0	XB288A0	XB288A0	XB288A0	XB288A0
s710	IC72	X	X	XZ287A0	XZ287A0	XZ287A0	XZ287A0	XZ287A0	XZ287A0
s711	IC73	X	X	XB096A0	XB096A0	XB096A0	XB096A0	XB096A0	XB096A0
s712	J701	X	X	RD35000	RD35000	RD35000	RD35000	RD35000	RD35000
s713	L703	X	X	PZ2012U600-3R0T	PZ2012U600-3R0T	PZ2012U600-3R0T	PZ2012U600-3R0T	PZ2012U600-3R0T	PZ2012U600-3R0T
s714	L702	X	X	DLW21HN900S02L	DLW21HN900S02L	DLW21HN900S02L	DLW21HN900S02L	DLW21HN900S02L	DLW21HN900S02L
s715	R701	X	X	WH20580	WH20580	WH20580	WH20580	WH20580	WH20580
s716	R718	X	X	RD35710	RD35710	RD35710	RD35710	RD35710	RD35710
s717	R711	X	X	RD35647	RD35647	RD35647	RD35647	RD35647	RD35647
s718	R715	X	X	WH21180	WH21180	WH21180	WH21180	WH21180	WH21180
s719	R722	X	X	RD35647	RD35647	RD35647	RD35647	RD35647	RD35647
s720	R725	X	X	RF45712	RF45712	RF45712	RF45712	RF45712	RF45712
s721	R734	X	X	RF45715	RF45715	RF45715	RF45715	RF45715	RF45715
s722	XL701	X	X	VS29490	VS29490	VS29490	VS29490	VS29490	VS29490
s723	C726	X	X	US06112	US06112	US06112	US06112	US06112	US06112
s724	R716	X	X	RD35510	RD35510	RD35510	RD35510	RD35510	RD35510

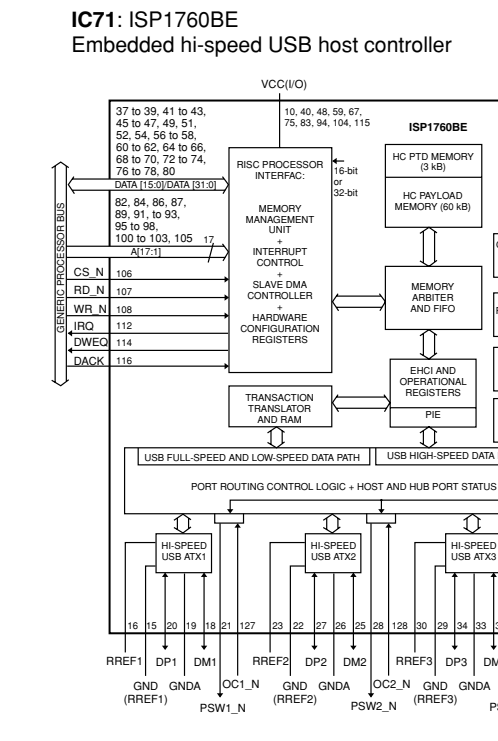
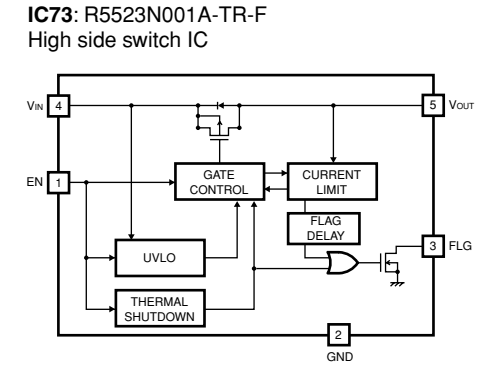
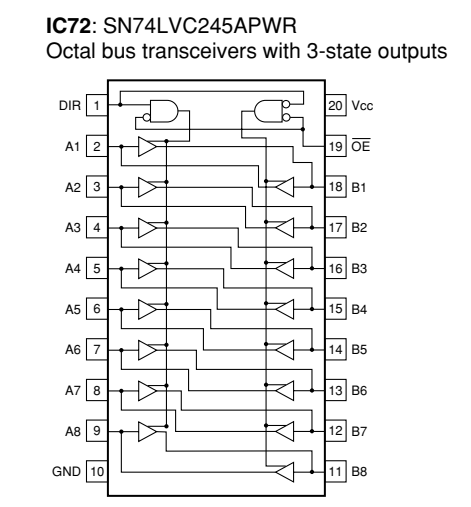
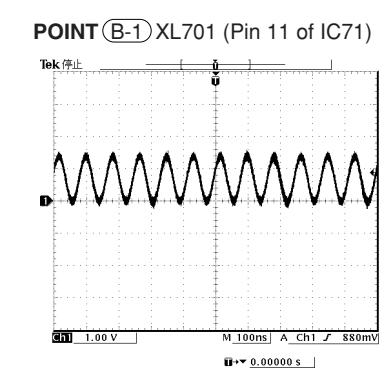

Page 91 [L4] to OPERATION (6), W6006 (R, T, K, A, B, G, E, F, L models)

\* All voltages are measured with a 10MΩ/V DC electronic voltmeter.  
 \* Components having special characteristics are marked with a triangle and must be replaced with parts having specifications equal to those originally installed.  
 \* Schematic diagram is subject to change without notice.

DSP 8/8

sxx	LOC	J	UC	R	TA	K	B	GEF	L	DESTINATION
s001	R025	RD35602 8.2K	RD35602 8.2K	RD35600 8.2K	RD35606 5.6K	RD35647 4.7K	RD35633 3.3K	RD35618 1.8K	RD35608 6.8K	DESTINATION
s002	R026	RD35610 1K	RD35622 2.2K	RD35633 3.3K	RD35656 5.6K	RD35668 6.8K	RD35682 8.2K	RD35682 8.2K	RD35647 4.7K	DETECTION

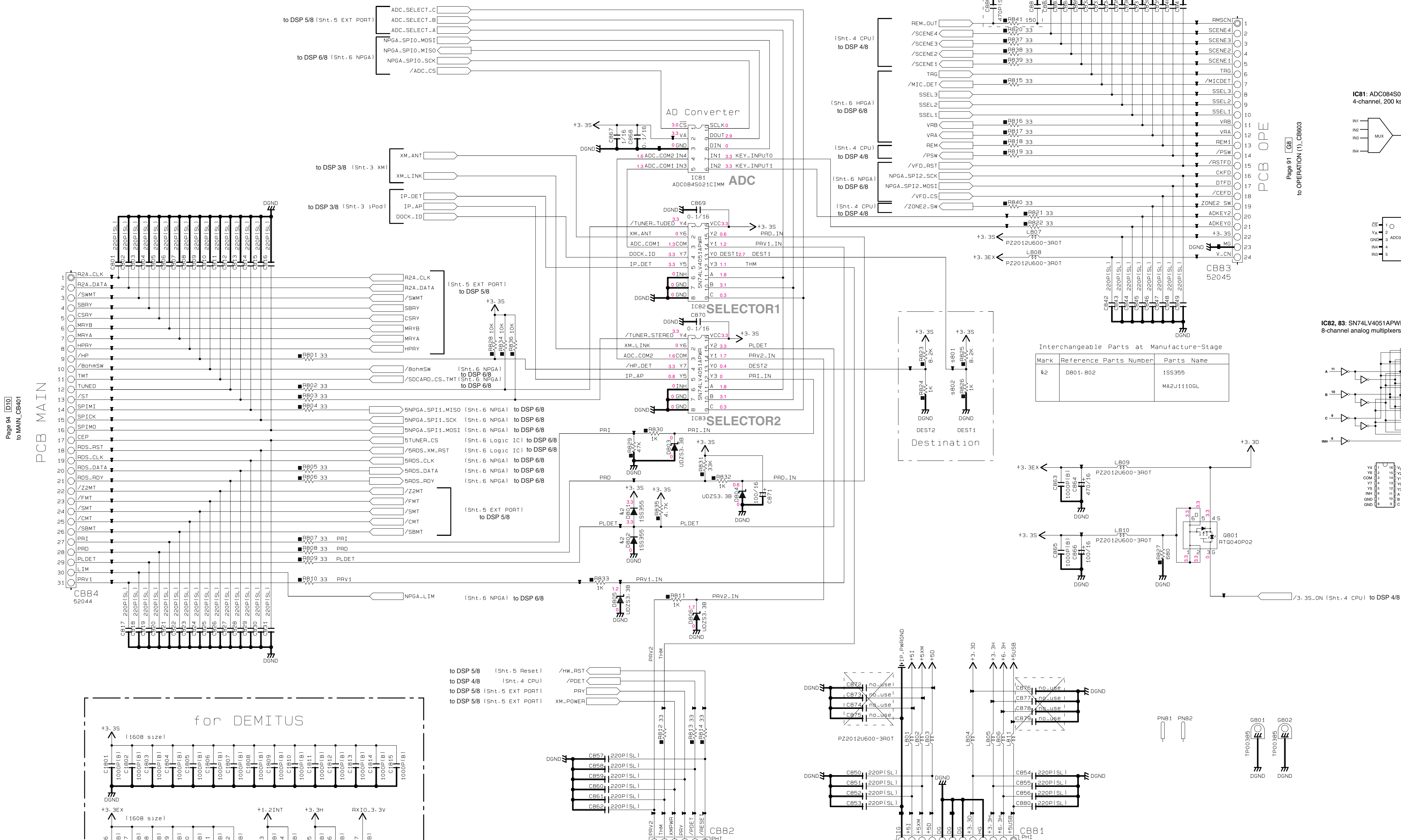

Page 94 [D10] to MAIN\_CB401

PCB MAIN

Page 81 [C8] to OPERATION (1)\_CB803

ICB1: ADC084S021 CIMM  
4-channel, 200 ksp/s, 8-bit A/D converter

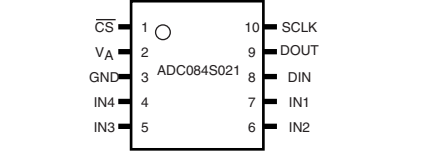
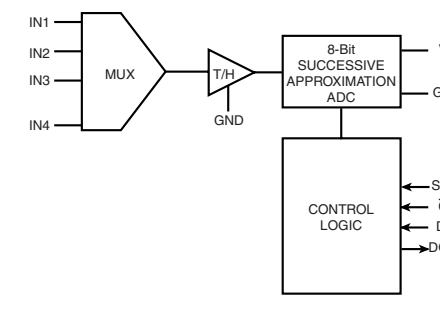

ICB2, 83: SN74LV4051APWR  
8-channel analog multiplexers/demultiplexers

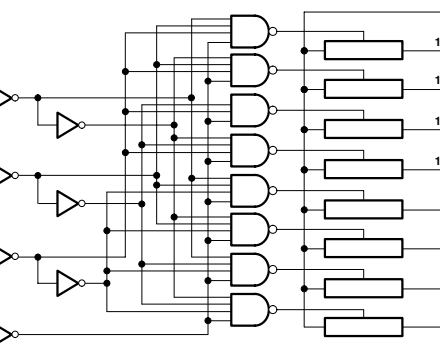

IN	C	B	A	CH	CHANNEL
Y4	L	L	L	L	Y0
Y3	L	L	L	L	Y1
Y2	L	L	L	L	Y2
Y1	L	L	L	L	Y3
Y0	L	L	L	L	Y4
IN4	L	L	L	L	Y5
IN3	L	L	L	L	Y6
IN2	L	L	L	L	Y7
IN1	L	L	L	L	None

Mark	Reference Parts Number	Parts Name
42	D001-002	1S5395
		MA2J1110GL

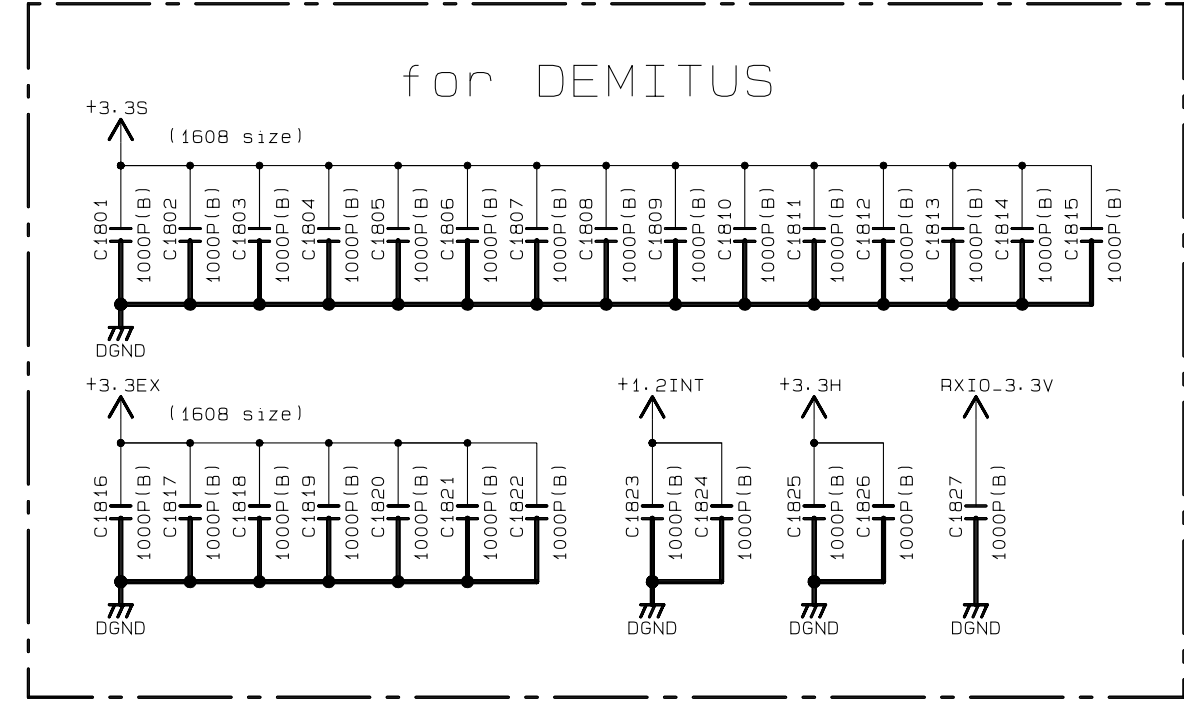

PCB POWER

Page 92 [B7] to OPERATION (2)\_W700

PCB POWER

Page 92 [B6] to OPERATION (2)\_W702

REMARKS	PARTS NAME	REMARKS	PARTS NAME
NO MARK	CARBON FILM RESISTOR (P=5)	NO MARK	ELECTROLYTIC CAPACITOR
□	CARBON FILM RESISTOR (P=10)	□	TANTALUM CAPACITOR
△	METAL OXIDE FILM RESISTOR	NO MARK	CERAMIC CAPACITOR
▲	METAL FILM RESISTOR	▲	CERAMIC TUBULAR CAPACITOR
⊠	METAL PLATE RESISTOR	○	POLYESTER FILM CAPACITOR
⊞	FIRE PROOF CARBON FILM RESISTOR	○	POLYSTYRENE FILM CAPACITOR
⊞	CEMENT MOLDED RESISTOR	○	MICA CAPACITOR
⊞	SEMI VARIABLE RESISTOR	○	POLYPROPYLENE FILM CAPACITOR
■	CHIP RESISTOR	○	SEMICONDUCTIVE CERAMIC CAPACITOR

\* All voltages are measured with a 10MΩ/V DC electronic voltmeter.  
\* Components having special characteristics are marked with a triangle and must be replaced with parts having specifications equal to those originally installed.  
\* Schematic diagram is subject to change without notice.

OPERATION 1/2

REMARKS	PARTS NAME
NO MARK	CARBON FILM RESISTOR (P=5)
□	CARBON FILM RESISTOR (P=10)
△	METAL OXIDE FILM RESISTOR
▲	METAL FILM RESISTOR
⊠	METAL PLATE RESISTOR
⊞	FIRE PROOF CARBON FILM RESISTOR
⊞	CEMENT MOLDED RESISTOR
⊞	SEMI VARIABLE RESISTOR
⊞	CHIP RESISTOR

REMARKS	PARTS NAME
NO MARK	ELECTROLYTIC CAPACITOR
⊙	TANTALUM CAPACITOR
NO MARK	CERAMIC CAPACITOR
⊙	CERAMIC TUBULAR CAPACITOR
⊙	POLYESTER FILM CAPACITOR
⊙	POLYSTYRENE FILM CAPACITOR
⊙	MICA CAPACITOR
⊙	POLYPROPYLENE FILM CAPACITOR
⊙	SEMICONDUCTIVE CERAMIC CAPACITOR
⊙	POLYBENZENE SULFIDE FILM CAPACITOR

OPERATION (9)

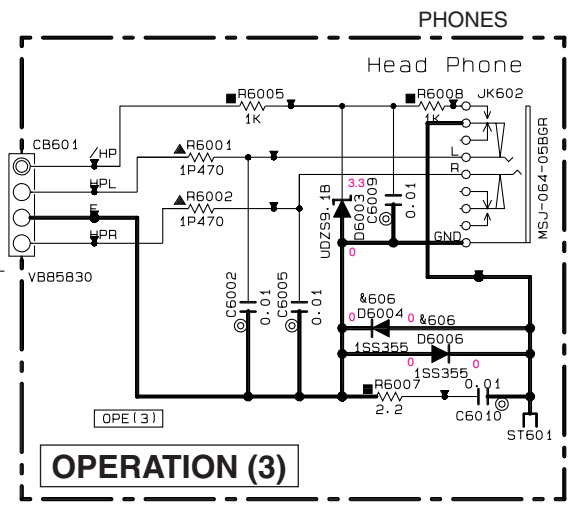
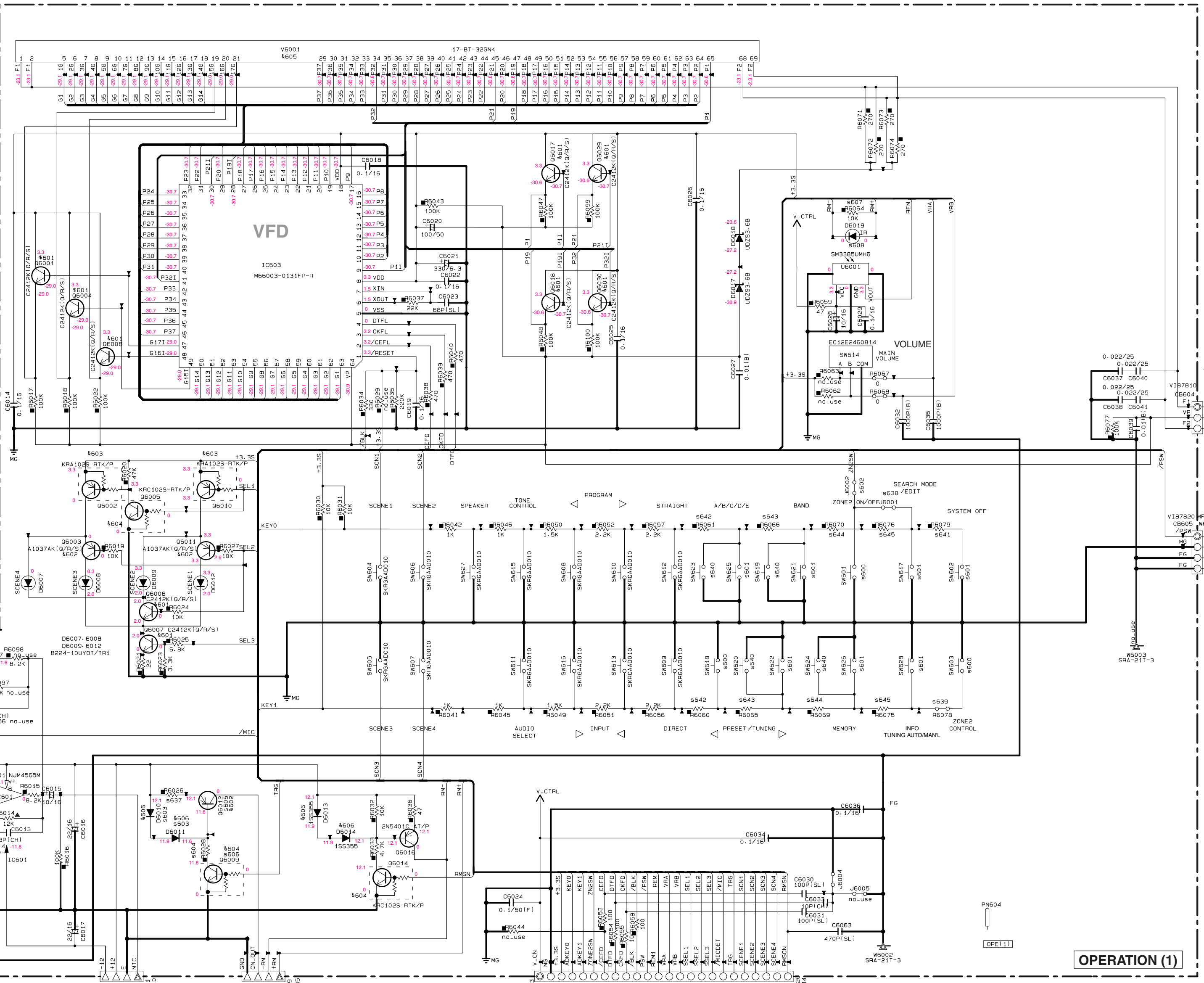
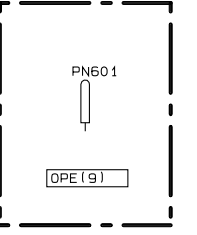

OPERATION (3)

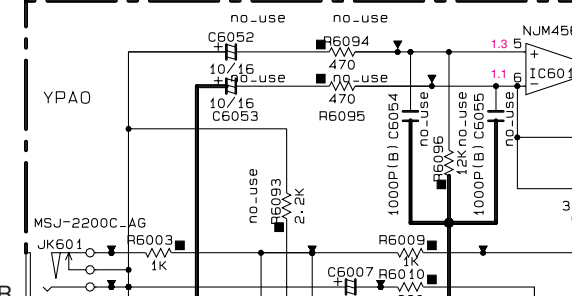

OPTIMIZER MIC

Interchangeable Parts at Manufacture-Stage

Mark	Reference Parts Number	Parts Name
4601	06001-6004-6006-6008	25C2412K1G/R/S1
	6017-6018-6029-6030	2898H8/8H/8V/S1
		KTC38785-V-GR-RTK/P
4602	06003-6011-6012	25A1037AK1G/R/S1
		KT415045-V-GR-RTK/P
4603	06002-6010	KR41025-RTK/P
		DT1414EXA
4604	06005-6009-6014	KRC1025-RTK/P
		DT1414EXA
4605	V6001	17-B1-329NK
		HNA-17M006T
4606	06001-6002-6004-6006	15S395
	6010-6011-6013-6014	M42J11109L
	6020-6027	

Key detection for A/D port  
Key input (A/D) pull-up resistance 10 k-ohms  
U.C.R.T.K.A.G.E.F.L models

Ohm	0	+1.0k	+1.5k	+2.2k	+2.2k	+3.3k	+4.7k	+6.8k	+10.0k	+22.0k
V	0-0.2	0.2-0.4	0.4-0.7	0.7-1.0	1.0-1.3	1.3-1.6	1.6-1.9	1.9-2.1	2.1-2.4	2.4-2.7
KEY	-	SPEAKERS	AB/DIFF	CONTROL	PROGRAM	PROGRAM	PROGRAM	STRAIGHT	AB/C/D/E	BAND
INPUT 0 (7 pin)	-	-	-	-	-	-	-	-	-	-
KEY	-	-	-	-	-	-	-	-	-	-
INPUT 1 (6 pin)	-	-	-	-	-	-	-	-	-	-

Ohm	0	+1.0k	+1.5k	+2.2k	+2.2k	+3.3k	+4.7k	+6.8k	+10.0k	+22.0k
V	0-0.2	0.2-0.4	0.4-0.7	0.7-1.0	1.0-1.3	1.3-1.6	1.6-1.9	1.9-2.1	2.1-2.4	2.4-2.7
KEY	-	SPEAKERS	AB/DIFF	CONTROL	PROGRAM	PROGRAM	PROGRAM	STRAIGHT	AB/C/D/E	BAND
INPUT 0 (7 pin)	-	-	-	-	-	-	-	-	-	-
KEY	-	-	-	-	-	-	-	-	-	-
INPUT 1 (6 pin)	-	-	-	-	-	-	-	-	-	-

NOTICE (mode1)

- (J)..... JAPAN
- (U)..... U. S. A
- (C)..... CANADA
- (R)..... GENERAL
- (T)..... CHINA
- (K)..... KOREA
- (A)..... AUSTRALIA
- (B)..... BRITISH
- (G)..... EUROPE
- (L)..... SINGAPORE
- (E)..... SOUTH EUROPE
- (V)..... TAIWAN
- (F)..... RUSSIAN

IC601: NJM4558M

Dual operational amplifier

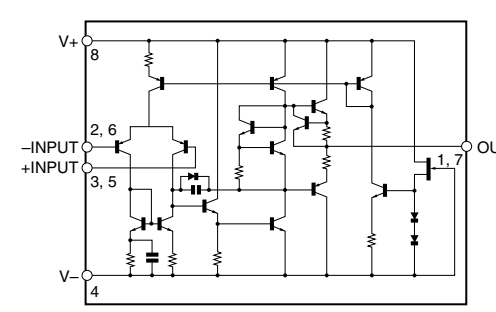

IC603: M66003-0131FP-R

18 digit 5 x 7 segment VFD controller/driver

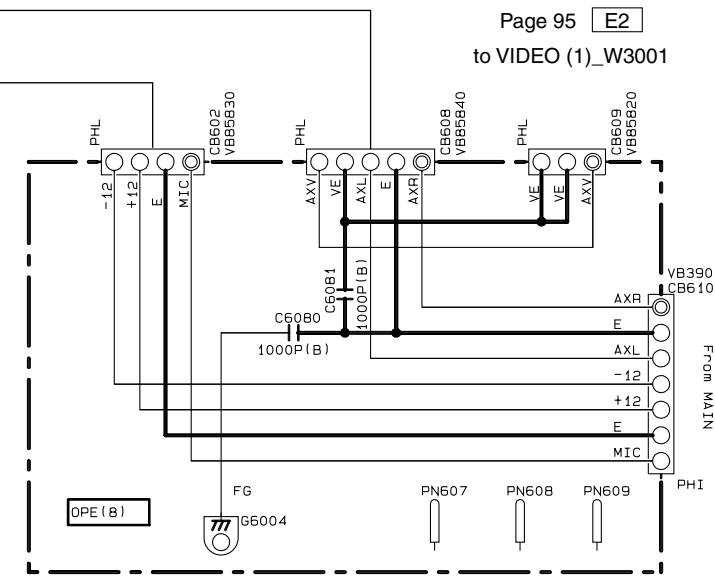
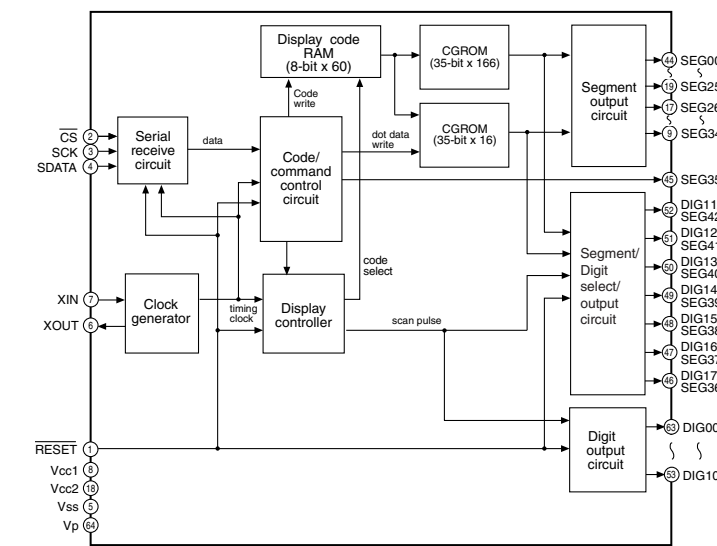

OPERATION (8)

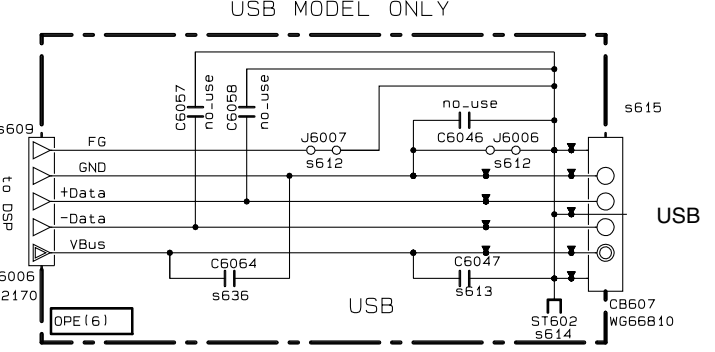

OPERATION (6)

R, T, K, A, B, G, E, F, L models

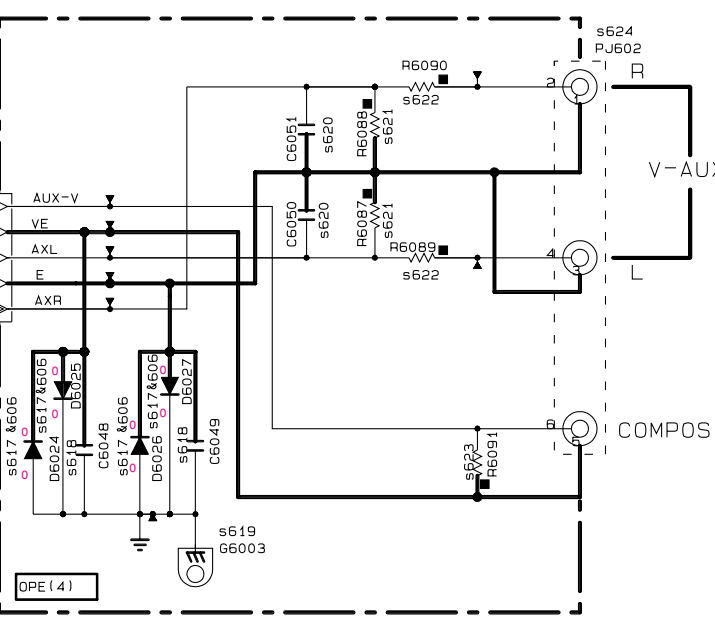

OPERATION (4)

R, T, K, A, B, G, E, F, L models

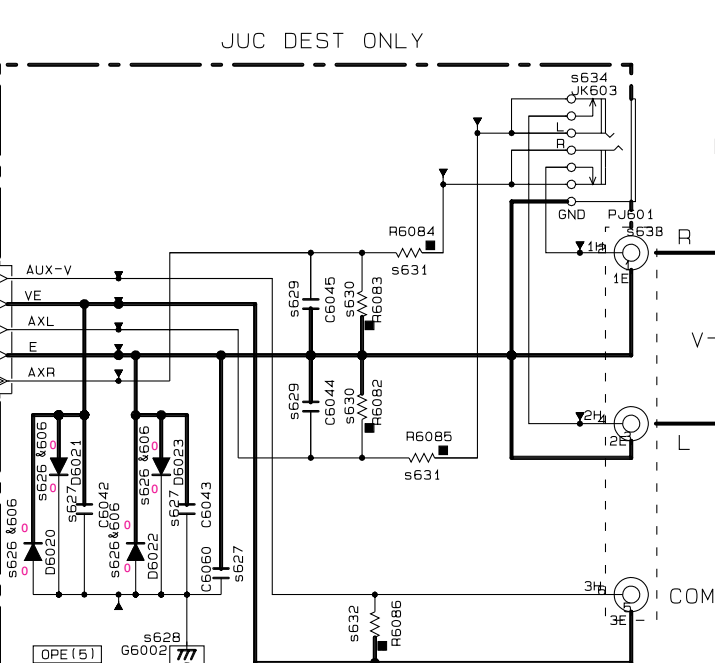

OPERATION (5)

U, C models

- ★ All voltages are measured with a 10MΩ/V DC electronic voltmeter.
- ★ Components having special characteristics are marked !, and must be replaced with parts having specifications equal to those originally installed.
- ★ Schematic diagram is subject to change without notice.

OPERATION 2/2

Interchangeable Parts at Manufacture-Stage

Mark	Reference Parts Number	Parts Name
&700	Q7000-7002	DTC114EKA KRC104S-RTK/P
&701	D7005-7006, 7010-7016 7017	1S5355 MA2J1110GL
&702	D7014, 7015	KBP1036 RS103
&703	D7018, 7019	RS403M-B-C-J80 TS4B03G-07
&704	Q7001	2SC2413K (Q/R/S) KTC3B755-Y, GR-RTK/P 2SD5014RL/AOL (Q/R/S)

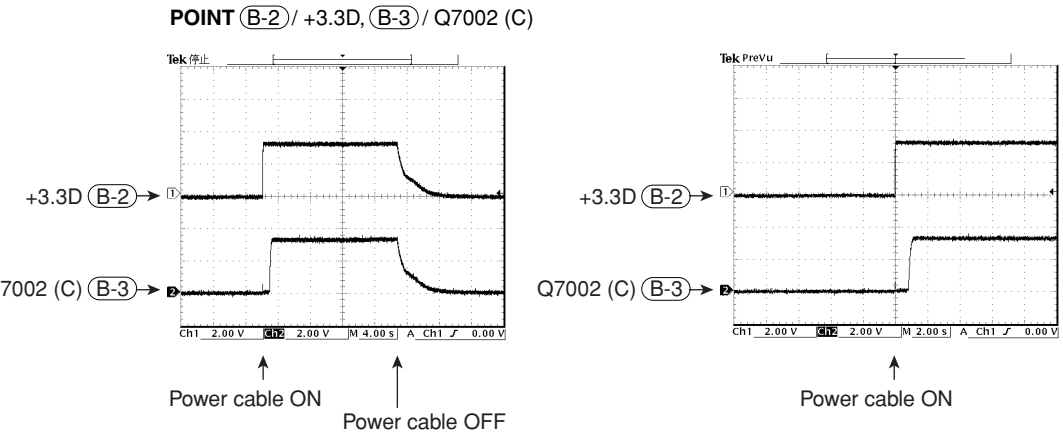

Page 96 [G9]  
to VIDEO (3)\_W3401

Page 90 [J9]  
to DSP\_CB81

Page 90 [G9]  
to DSP\_CB82

Page 93 [I6]  
to MAIN\_W506

Page 95 [B2]  
to VIDEO (1)\_CB301

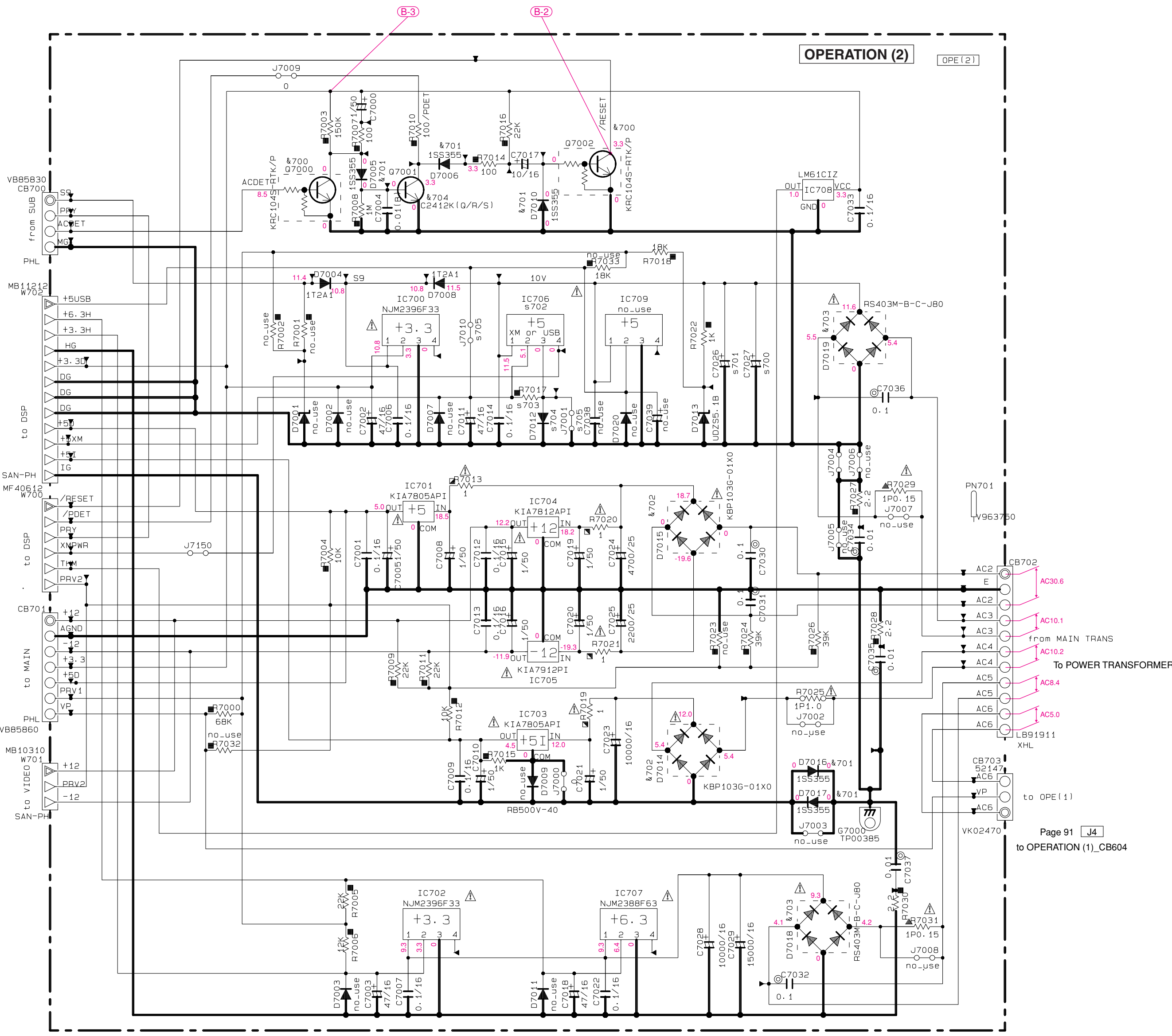

REMARKS	PARTS NAME	REMARKS	PARTS NAME
NO MARK	CARBON FILM RESISTOR (P=5)	NO MARK	ELECTROLYTIC CAPACITOR
△	CARBON FILM RESISTOR (P=10)	⊗	TANTALUM CAPACITOR
▲	METAL OXIDE FILM RESISTOR	NO MARK	CERAMIC CAPACITOR
⊠	METAL FILM RESISTOR	⊙	CERAMIC TUBULAR CAPACITOR
■	METAL PLATE RESISTOR	⊖	POLYESTER FILM CAPACITOR
▨	FINE PROOF CARBON FILM RESISTOR	⊕	POLYSTYRENE FILM CAPACITOR
□	CEMENT MOLDED RESISTOR	⊘	MICA CAPACITOR
⊖	SEMI VARIABLE RESISTOR	⊙	POLYPROPYLENE FILM CAPACITOR
■	CHIP RESISTOR	⊖	SEMICONDUCTIVE CERAMIC CAPACITOR

NOTICE (mode1)  
(J)..... JAPAN  
(U)..... U.S.A  
(C)..... CANADA  
(R)..... GENERAL  
(T)..... CHINA  
(K)..... KOREA  
(A)..... AUSTRALIA  
(B)..... BRITISH  
(G)..... EUROPE  
(L)..... SINGAPORE  
(E)..... SOUTH EUROPE  
(V)..... TAIWAN  
(F)..... RUSSIAN

sXX	LOC	UC	RTKAGEFL	B
s600	SW601 SW619 SW603	WD48310 SKRGAAD010	WD48310 SKRGAAD010	X
s601	SW602 SW617 SW621 SW626 SW628 SW625 SW622	WD48310 SKRGAAD010	WD48310 SKRGAAD010	X
s602	J6002	VN50000 0	VN50000 0	X
s603	D6010 D6011	VT33290 1S5355	VT33290 1S5355	X
s604	R6028	RD35647 4.7K	RD35647 4.7K	X
s605	Q6012	VV56550 A1037AK (Q/R/S)	VV56550 A1037AK (Q/R/S)	X
s606	Q6009	VV65540 DTC114EKA	VV65540 DTC114EKA	X
s607	R6054	RD35710 10K	RD35710 10K	X
s608	D6019	V256820 SIR-805STA47	V256820 SIR-805STA47	X
s609	W6006	X	WN02170 WN02170	
s612	J6007 J6006	X	RD35000 0	RD35000 0
s613	C6047	X	US06210 100P (SL)	US06210 100P (SL)
s614	ST602	X	WA78970 WA78970	
s615	CB607	X	W656810 UBA-4R-D141T-4D	W656810 UBA-4R-D141T-4D
s616	W6008	X	WJ52450 SAN-PH	WJ52450 SAN-PH
s617	D6026 D6027 D6024	X	VT33290 1S5355	VT33290 1S5355
s618	C6049 C6048	X	US13510 0.1/16	US13510 0.1/16
s619	G6003	X	VR46340 TP00385	VR46340 TP00385
s620	C6050 C6051	X	US06222 220P (SL)	US06222 220P (SL)
s621	R6088 R6087	X	RD35847 470K	RD35847 470K
s622	R6090 R6089	X	RD35547 470	RD35547 470
s623	R6091	X	RD35475 75	RD35475 75
s624	PJ602	X	WJ11750 MSP-303H-BBB-11	WJ11750 MSP-303H-BBB-11
s625	W6007	X	WJ62450 SAN-PH	
s626	D6020 D6021 D6022 D6023	X	VT33290 1S5355	
s627	C6043 C6060	X	US13510 0.1/16	
s628	G6002	X	VR46340 TP00385	
s629	C6045 C6044	X	US06368 6800P (B)	
s630	R6082 R6083	X	RD35847 470K	
s631	R6085 R6084	X	RD35547 470	
s632	R6086	X	RD35475 75	
s633	PJ601	X	WJ11750 MSP-303H-BBB-11	
s634	JK603	X	WJ11740 MSJ-035-05A	
s636	C6054	X	US12510 1/10	US12510 1/10
s637	R6026	X	RD35427 27	
s638	J6001	X	X	
s639	R6078	X	RD35722 22K	
s640	SW619 SW624 SW620 SW623	X	X	
s641	R6079	X	RD35722 22K	
s642	R6060 R6061	X	RD35633 3.3K	
s643	R6065 R6066	X	RD35647 4.7K	
s644	R6069 R6070	X	RD35668 6.8K	
s645	R6076 R6075	X	RD35710 10K	
s700	C7027	W660200 15000/16	W660200 15000/16	
s701	C7026	UR03947 4700/16	UR03947 4700/16	
s702	IC706	X6143A0 NJM2388F05	X6143A0 NJM2388F05	
s703	R7017	RD35610 1K	X	
s704	D7012	V237660 RB500V-40	X	
s705	J7001 J7010	X	VN50000 VN50000	

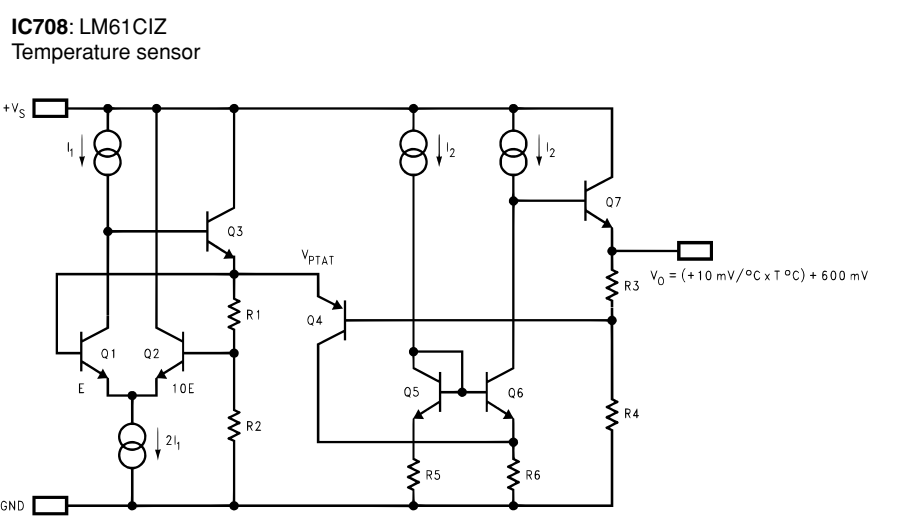
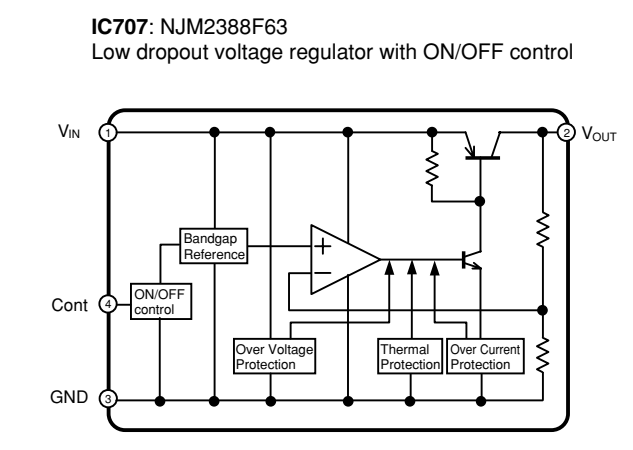
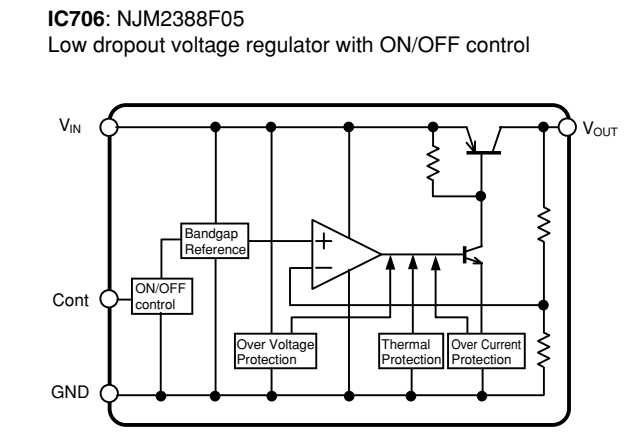
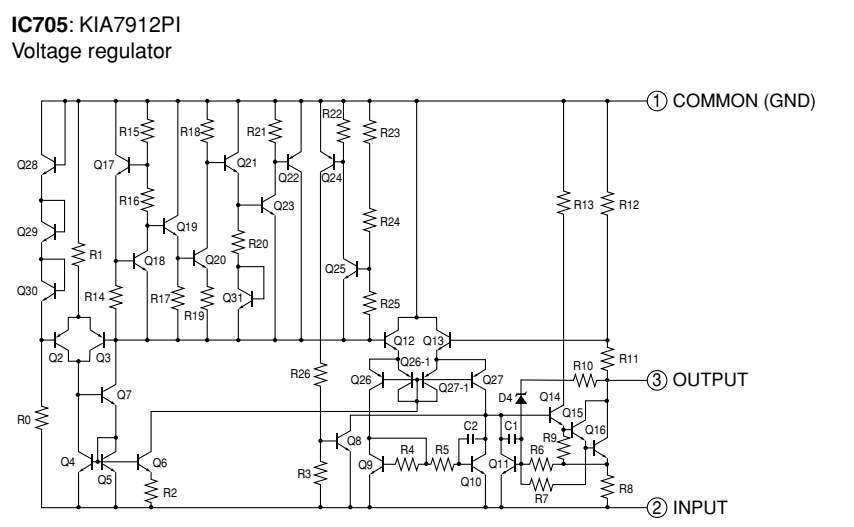
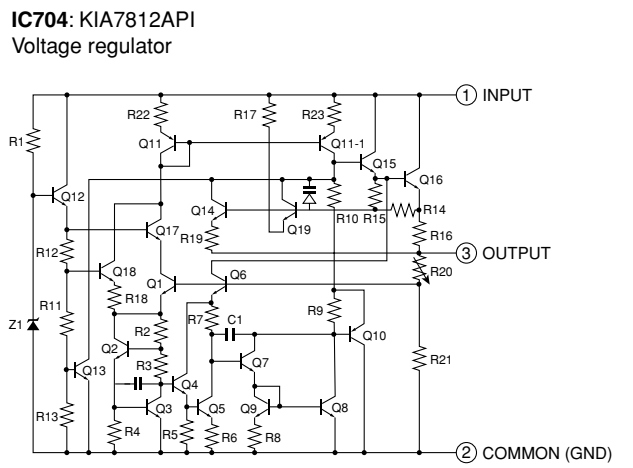
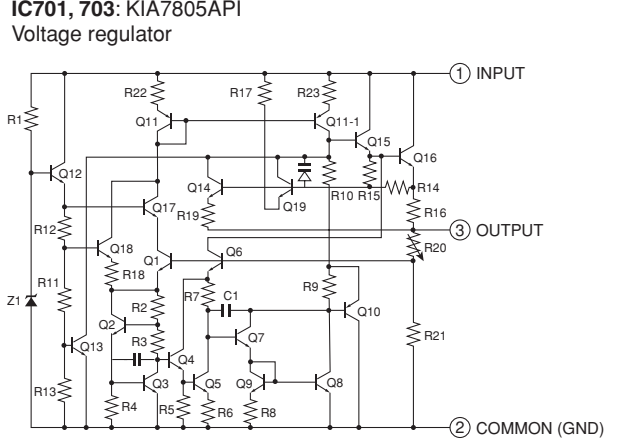

\* All voltages are measured with a 10MΩ/V DC electronic voltmeter.  
\* Components having special characteristics are marked with a triangle and must be replaced with parts having specifications equal to those originally installed.  
\* Schematic diagram is subject to change without notice.

MAIN 1/2

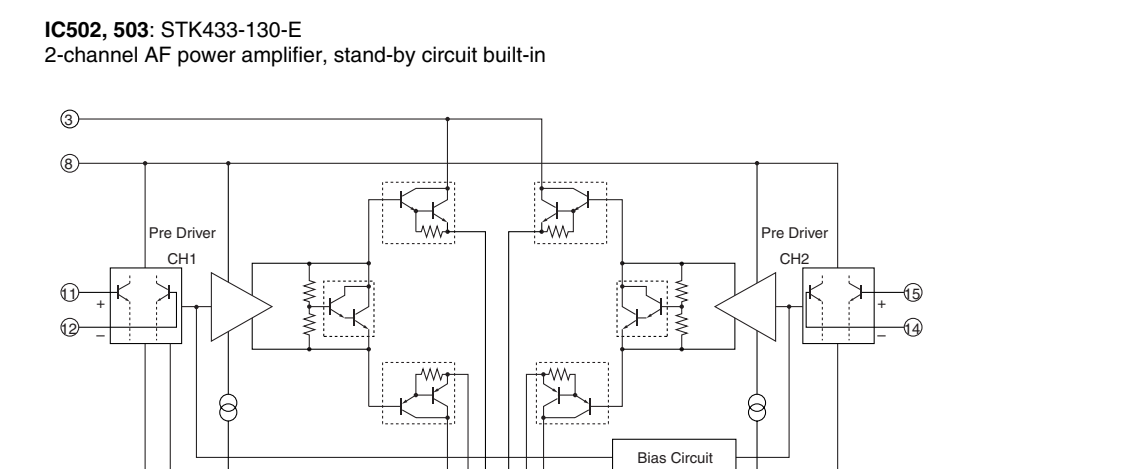
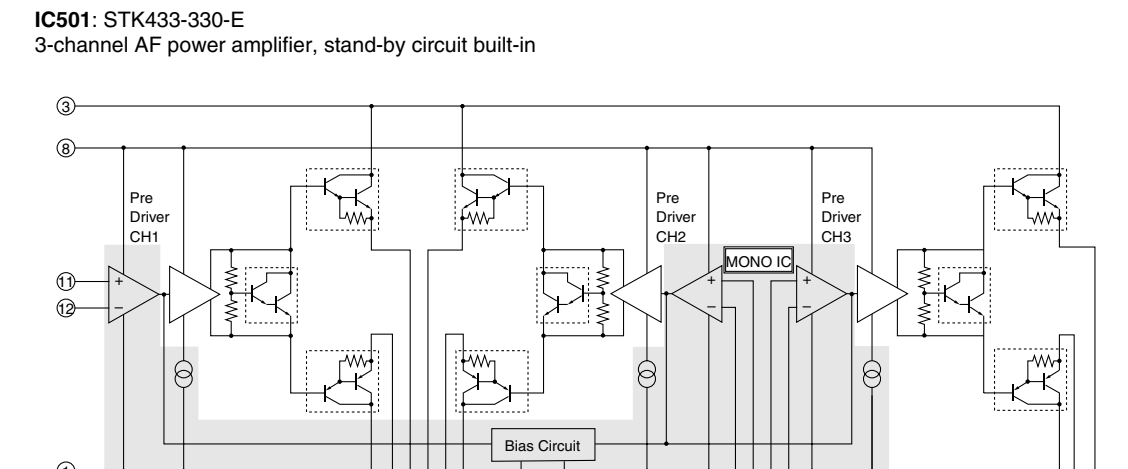
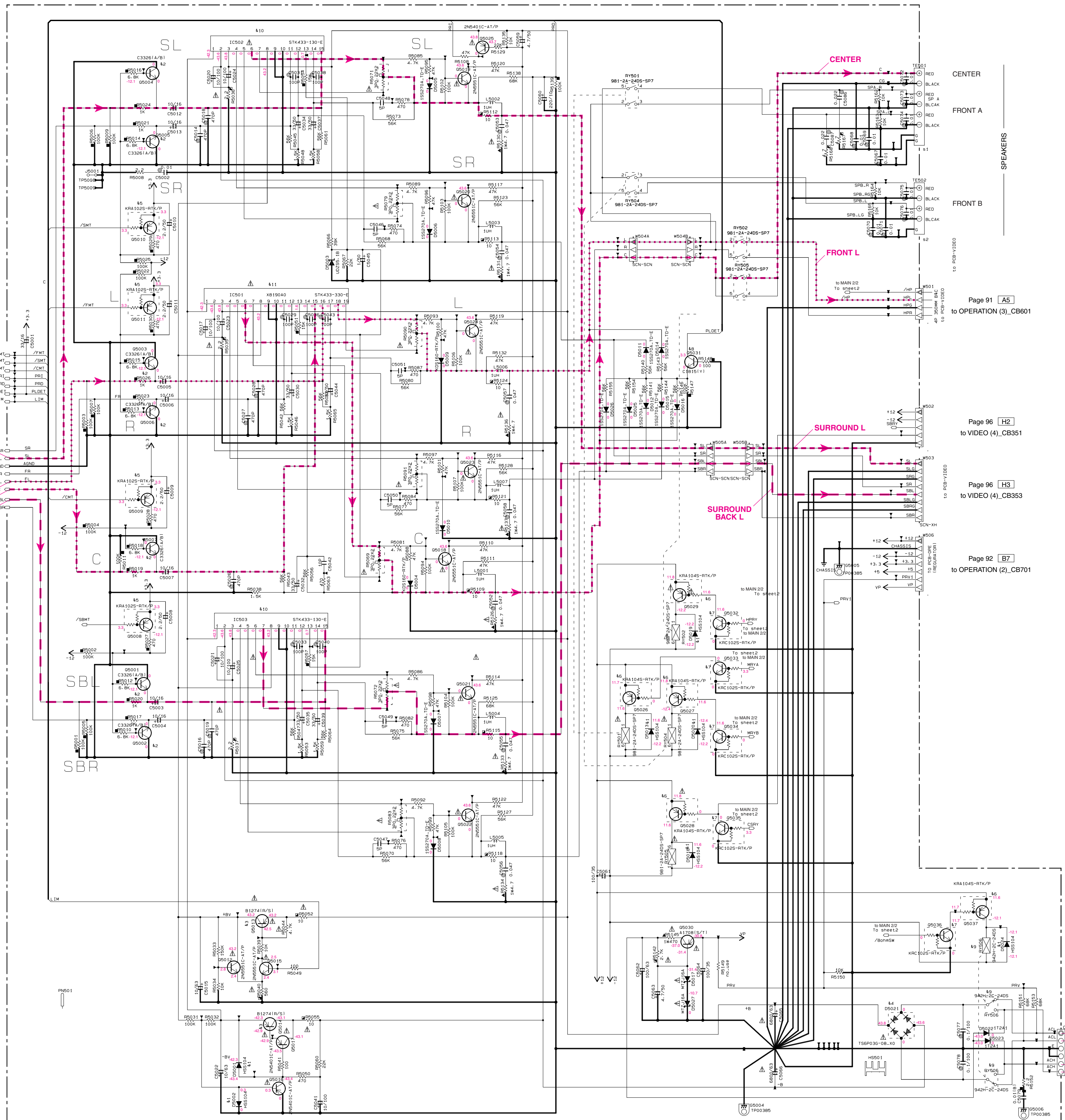

Page 91 [A5] to OPERATION (3)\_CB601

Page 96 [H2] to VIDEO (4)\_CB351

Page 96 [H3] to VIDEO (4)\_CB353

Page 92 [B7] to OPERATION (2)\_CB701

Interchangeable Parts at Manufacture-Stage

Mark	Reference Parts Number	Parts Name
41	05001-5002-5013 5018-5020-5024	RES104 155133 155176
42	05001-5007	25C33261A/B1 25C33261B1 25C593841A/B1 25C19381F15/1 25C2724K
43	05013-5014	25H12741H/S1 25H15551E/F1 K1A1046-Y-U/P
44	05021	T5P0330-08-X0 R5603W-B-C-J80
45	05008-5011	KRA1025-RTK/P DTA114EK4
46	05020-5029-5037	KRA1045-RTK/P DTA144EK4
47	05032-5036	KRC1025-RTK/P DTC114EK4
48	05031	25C18101Y1 K1C3196 Y-A1
49	RY506	942H-2C-2405 DH2402-O-G
410	IC502-503	STK-433-130-E 1X7427A01 STK-433-130-E 1X7427B01 STK-433-330-E 1X8190A01 STK-433-330-E 1X8190B01

REMARKS PARTS NAME

REMARKS	PARTS NAME
NO MARK	ELECTROLYTIC CAPACITOR
⊗	TANTALUM CAPACITOR
NO MARK	CERAMIC CAPACITOR
⊙	CERAMIC TUBULAR CAPACITOR
⊕	POLYESTER FILM CAPACITOR
⊖	POLYSTYRENE FILM CAPACITOR
⊙	MICA CAPACITOR
⊕	POLYPROPYLENE FILM CAPACITOR
⊖	SEMICONDUCTIVE CERAMIC CAPACITOR
⊕	POLYPHENYLENE SULFIDE FILM CAPACITOR
REMARKS	PARTS NAME
NO MARK	CARBON FILM RESISTOR [D=5]
⊕	CARBON FILM RESISTOR [D=10]
Δ	METAL OXIDE FILM RESISTOR
⊗	METAL FILM RESISTOR
⊕	METAL PLATE RESISTOR
⊖	FIRE PROOF CARBON FILM RESISTOR
⊕	CEMENT MOLDED RESISTOR
⊖	SEMI-VARIABLE RESISTOR
■	CHIP RESISTOR

**NOTICE** [mode1]

(J)..... JAPAN  
(U)..... U.S.A  
(C)..... CANADA  
(R)..... GENERAL  
(T)..... CHINA  
(K)..... KOREA  
(A)..... AUSTRALIA  
(B)..... BRITISH  
(G)..... EUROPE  
(L)..... SINGAPORE  
(E)..... SOUTH EUROPE  
(V)..... TAIWAN  
(F)..... RUSSIAN

\* All voltages are measured with a 10MΩ/V DC electronic voltmeter.  
\* Components having special characteristics are marked !, and must be replaced with parts having specifications equal to those originally installed.  
\* Schematic diagram is subject to change without notice.

MAIN 2/2

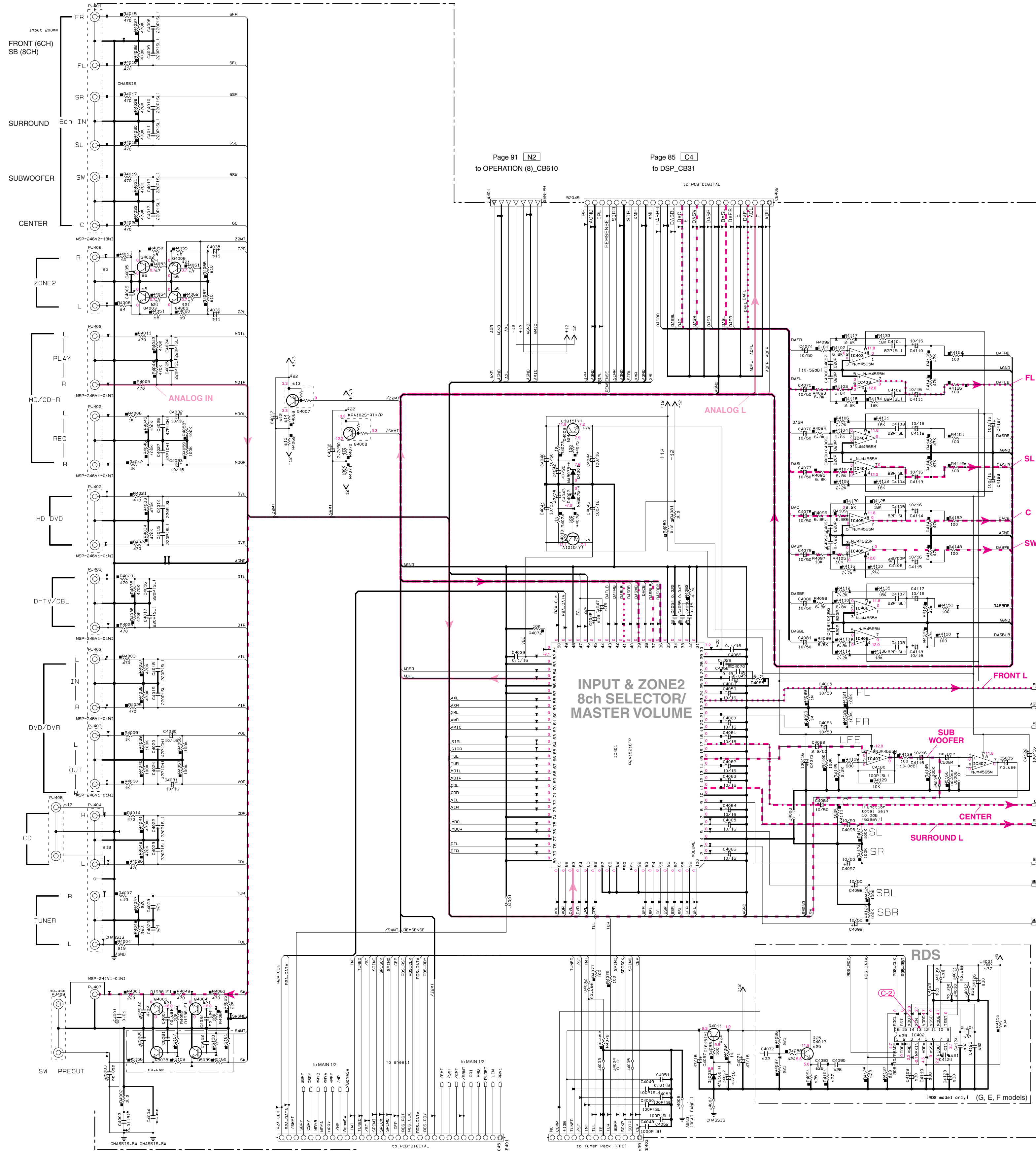

Interchangeable Parts at Manufacture-Stage

Mark	Reference Parts Number	Parts Name
421	04001-0006	25D1938(F) 25C5938A1A/B1 25D270-4K
422	04007-4008	KRA1025-RTK/P DTA114EK4
423	04010	25A10101(V) KTA1266 Y-AT
424	04009-4011	25C18101(V) KTC398 Y-AT
425	04012	25C14051A/S1 25C31148A10/P/S1

DEFINITION	PART LIST	LOC	U	LCR1A	KL	B	SEP
91	TE001	W56100	W56100	W56110	W56110	W56110	W56110
92	TE002	M56080	M56080	M56090	M56090	M56090	M56090
93	PL400	M56170	M56170	M56170	M56170	M56170	M56170
94	R4008	R03522	R03522	R03522	R03522	R03522	R03522
95	C4006	U506147	U506147	U506147	U506147	U506147	U506147
96	D4002	V72980	V72980	V72980	V72980	V72980	V72980
97	R4024	R03910	R03910	R03910	R03910	R03910	R03910
98	R4021	R03533	R03533	R03533	R03533	R03533	R03533
99	R4025	R03568	R03568	R03568	R03568	R03568	R03568
100	R4026	R039810	R039810	R039810	R039810	R039810	R039810
101	C4036	U983710	U983710	U983710	U983710	U983710	U983710
102	C4037	U98622	U98622	U98622	U98622	U98622	U98622
103	04007	KC4380	KC4380	KC4380	KC4380	KC4380	KC4380
104	R4058	R03547	R03547	R03547	R03547	R03547	R03547
105	R4059	R039810	R039810	R039810	R039810	R039810	R039810
106	C4046	U983710	U983710	U983710	U983710	U983710	U983710
107	PL408	M56170	M56170	M56170	M56170	M56170	M56170
108	PL404	M56170	M56170	M56170	M56170	M56170	M56170
109	R4077	R039810	R039810	R039810	R039810	R039810	R039810
110	R4078	R039810	R039810	R039810	R039810	R039810	R039810
111	C4028	U98622	U98622	U98622	U98622	U98622	U98622
112	C4029	U98622	U98622	U98622	U98622	U98622	U98622
113	C4012	U983710	U983710	U983710	U983710	U983710	U983710
114	R4088	R039810	R039810	R039810	R039810	R039810	R039810
115	04012	VC7402	VC7402	VC7402	VC7402	VC7402	VC7402
116	R4081	R039810	R039810	R039810	R039810	R039810	R039810
117	R4101	R039810	R039810	R039810	R039810	R039810	R039810
118	C4095	U506233	U506233	U506233	U506233	U506233	U506233
119	C4002	V72980	V72980	V72980	V72980	V72980	V72980
120	C4011	U983710	U983710	U983710	U983710	U983710	U983710
121	C4124	U98622	U98622	U98622	U98622	U98622	U98622
122	C4125	U98622	U98622	U98622	U98622	U98622	U98622
123	XL401	U983710	U983710	U983710	U983710	U983710	U983710
124	R4156	R039810	R039810	R039810	R039810	R039810	R039810
125	C4120	U983710	U983710	U983710	U983710	U983710	U983710
126	J4012	U983710	U983710	U983710	U983710	U983710	U983710
127	J4009	U983710	U983710	U983710	U983710	U983710	U983710
128	L4001	M78730	M78730	M78730	M78730	M78730	M78730
129	C4119	U983710	U983710	U983710	U983710	U983710	U983710
130	04003	V90290	V90290	V90290	V90290	V90290	V90290

IC401: R2A15218FP  
8-channel electronic volume with 11 input selector and tone control

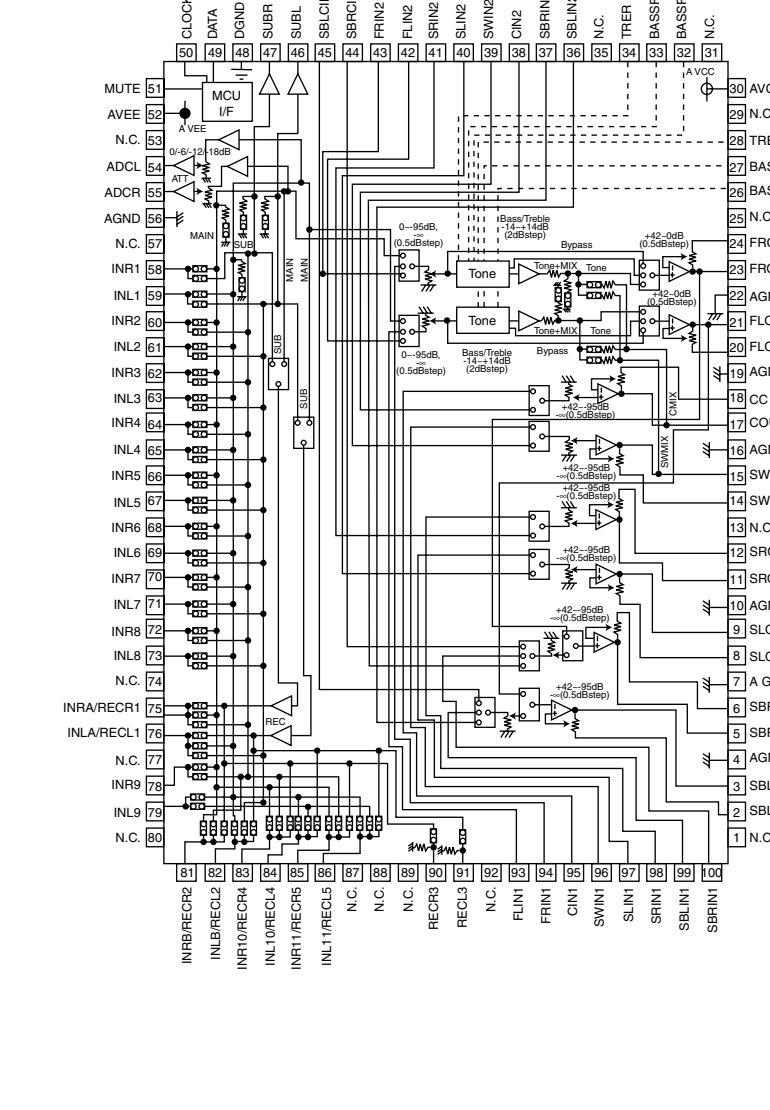

IC402: LC72725KM-UY-TLM-E  
RDS signal demodulation IC

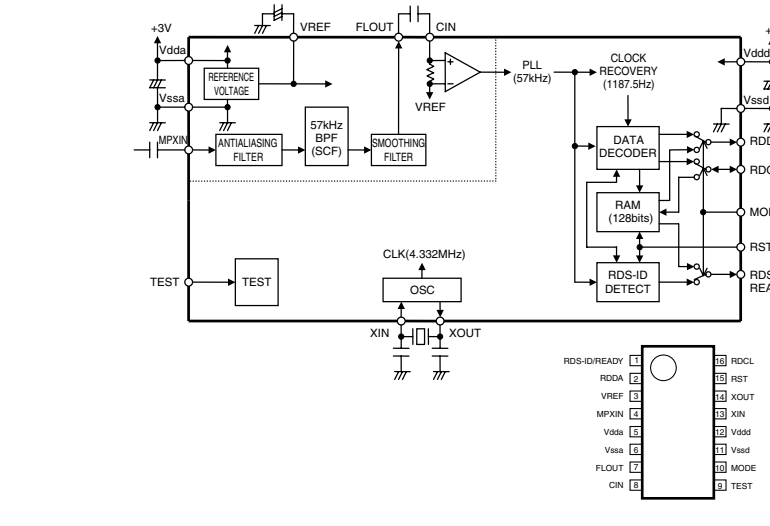

IC403-407: NJM4565M  
Dual operational amplifier

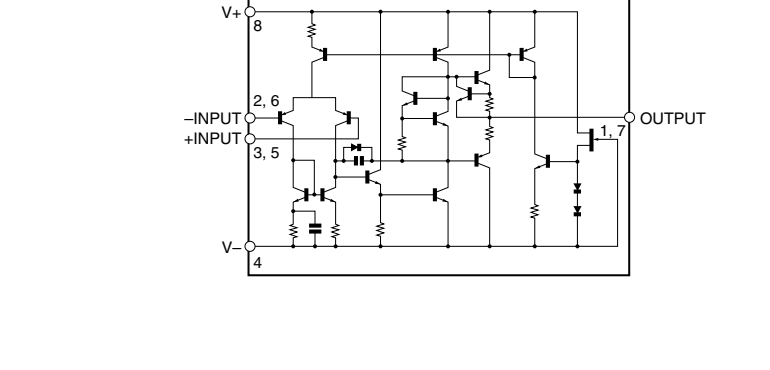

CAPACITOR

REMARKS	PARTS NAME	UNIT
NO MARK	ELECTROLYTIC CAPACITOR	μF
NO MARK	TANTALUM CAPACITOR	μF
NO MARK	CERAMIC CAPACITOR	μF
○	CERAMIC TUBULAR CAPACITOR	μF
○	POLYESTER FILM CAPACITOR	μF
○	POLYETHYLENE FILM CAPACITOR	μF
○	MICA CAPACITOR	μF
○	POLYPROPYLENE FILM CAPACITOR	μF
○	SEMICONDUCTIVE CERAMIC CAPACITOR	μF

RESISTOR

REMARKS	PARTS NAME	UNIT
NO MARK	CARBON FILM RESISTOR (P=5)	Ω
NO MARK	CARBON FILM RESISTOR (P=10)	Ω
△	METAL OXIDE FILM RESISTOR	Ω
○	METAL FILM RESISTOR	Ω
○	METAL PLATE RESISTOR	Ω
○	FIRE PROOF CARBON FILM RESISTOR	Ω
○	CEMENT MOLDED RESISTOR	Ω
○	SEMI-VARIABLE RESISTOR	Ω
○	CHIP RESISTOR	Ω

NOTICE (mode)

(J) JAPAN  
(U) U.S.A.  
(C) CANADA  
(R) GENERAL  
(T) CHINA  
(K) KOREA  
(A) AUSTRALIA  
(B) BRITISH  
(G) EUROPE  
(L) SINGAPORE  
(E) SOUTH EUROPE  
(V) TAIWAN  
(F) RUSSIAN

POINT (C2) XL401 (Pin 13 of IC402)

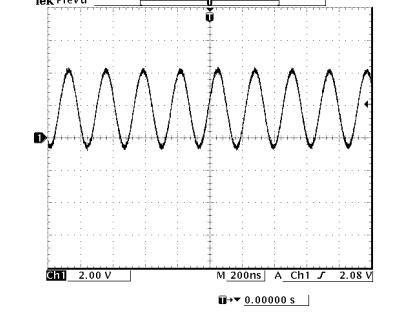

\* All voltages are measured with a 10MΩ DC electronic voltmeter.  
\* Components having special characteristics are marked  $\Delta$  and must be replaced with parts having specifications equal to those originally installed.  
\* Schematic diagram is subject to change without notice.

VIDEO 1/2

Page 92 [B3] to OPERATION (2)\_W701

Page 91 [M2] to OPERATION (8)\_CB609

Page 85 [B3] to DSP\_CB32

Interchangeable Parts at Manufacture-Stage

Mark	Reference Parts Number	Parts Name
4301	D3001-3002-3201-3217 D3651-3652	1SS355 MA2J11100L
4302	Q3004-3005	2SC2412K (Q/R/S) 2SC6914RL/AQL (Q/R/S) KT3C3875S-Y-GR-RTK/P
4303	IC301-303	MM74HC4051SJX-NL TC74HC4051AF [EL.F]
4304	IC327	MM74HC4053SJX-NL TC74HC4053AF [EL.F]
4305	Q3001-3003-3201-3203	2SA1037AK (Q/R/S) KTA1504S-Y-GR-RTK/P
4306	IC310-311-321-324	TC74HC4052AF [EL.F] MM74HC4052SJX-NL
4307	D3401-3501-3502	H5S104 1SS133 1SS176
4308	Q3402-3404	2SA1015(Y) KTA1266(Y)
4309	D3501-3503	DTA114ESA KRA102M-AT

Page 84 [M3] to DSP\_CB21

Page 96 [C1] to VIDEO (2)\_CB325

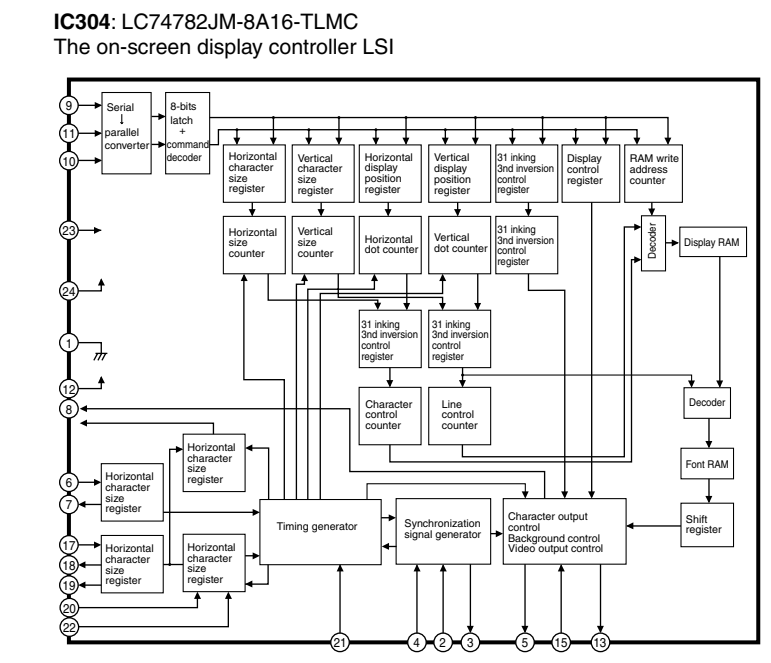
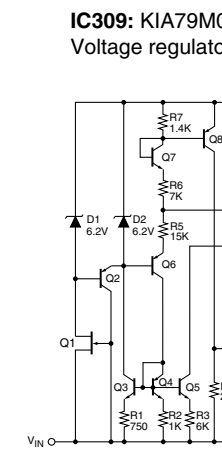
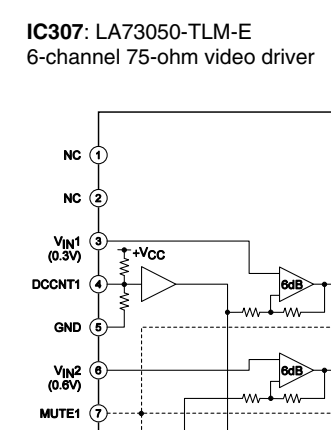
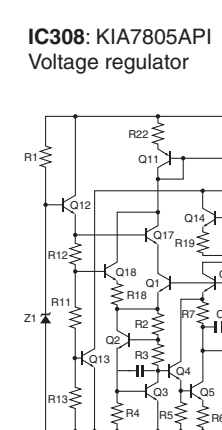
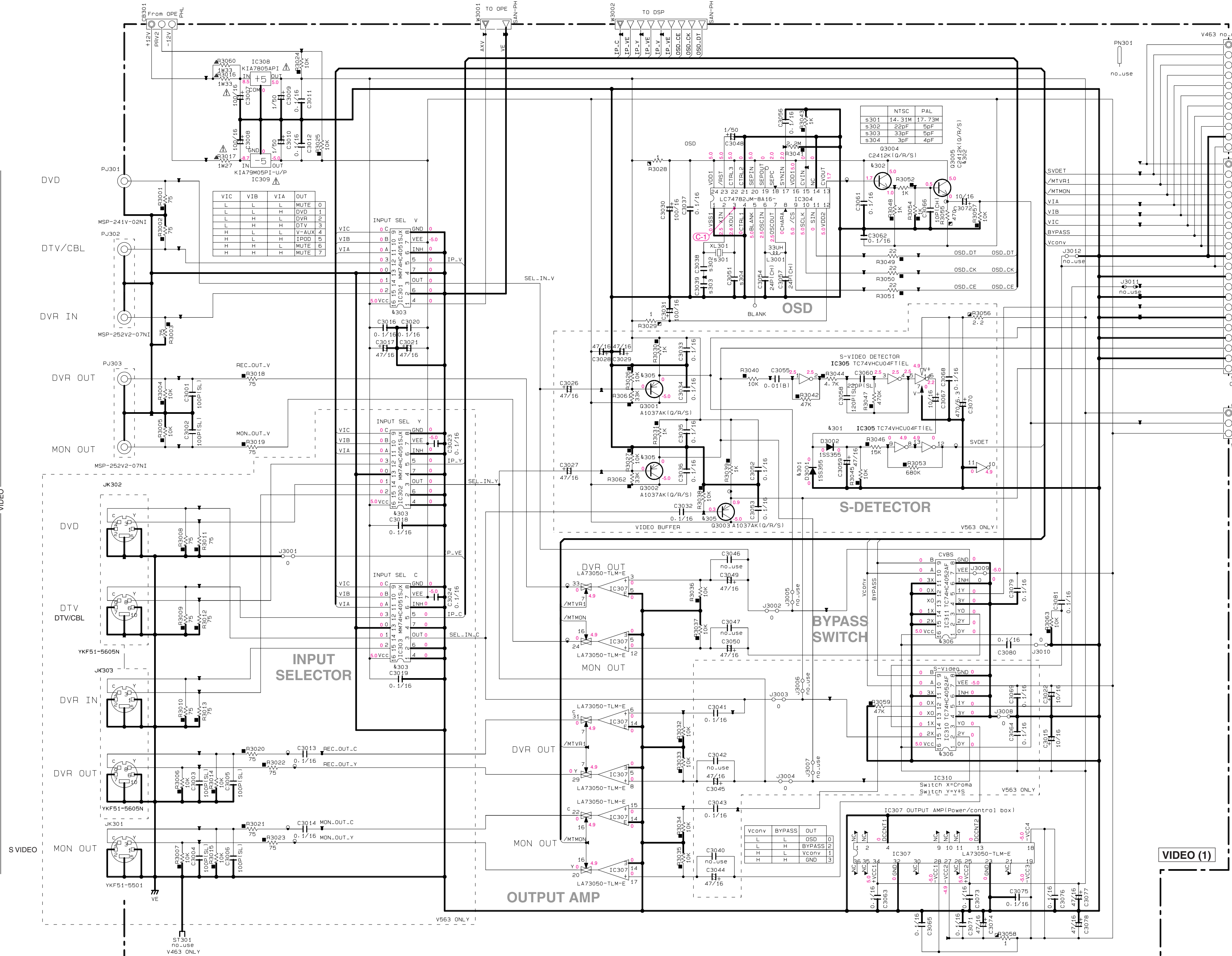
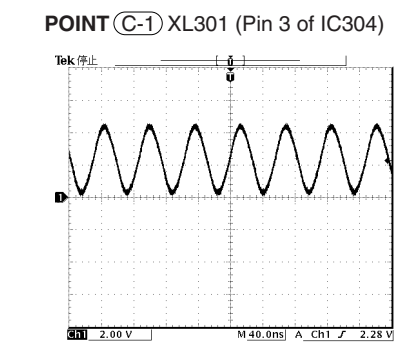

NOTICE (model1)  
 (J)..... JAPAN  
 (U)..... U.S.A  
 (C)..... CANADA  
 (R)..... GENERAL  
 (T)..... CHINA  
 (K)..... KOREA  
 (A)..... AUSTRALIA  
 (B)..... BRITISH  
 (G)..... EUROPE  
 (L)..... SINGAPORE  
 (E)..... SOUTH EUROPE  
 (V)..... TAIWAN  
 (F)..... RUSSIAN

REMARKS	PARTS NAME
NO MARK	CARBON FILM RESISTOR (P=5)
□	CARBON FILM RESISTOR (P=10)
△	METAL OXIDE FILM RESISTOR
T	METAL FILM RESISTOR
⊠	METAL PLATE RESISTOR
⊞	FIRE PROOF CARBON FILM RESISTOR
□	CEMENT MOLDED RESISTOR
⊞	SEMI VARIABLE RESISTOR
■	CHIP RESISTOR

REMARKS	PARTS NAME
NO MARK	ELECTROLYTIC CAPACITOR
⊗	TANTALUM CAPACITOR
NO MARK	CERAMIC CAPACITOR
⊞	CERAMIC TUBULAR CAPACITOR
⊙	POLYESTER FILM CAPACITOR
○	POLYSTYRENE FILM CAPACITOR
⊖	MICA CAPACITOR
⊕	POLYPROPYLENE FILM CAPACITOR
⊗	SEMICONDUCTIVE CERAMIC CAPACITOR

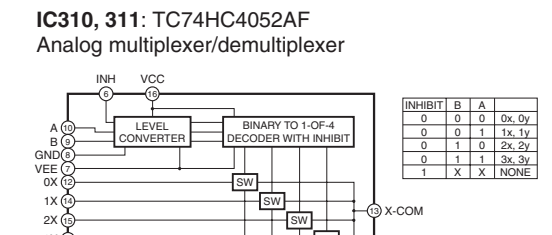
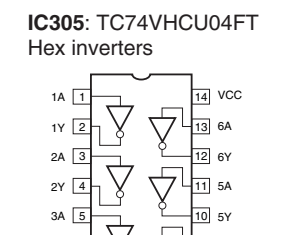
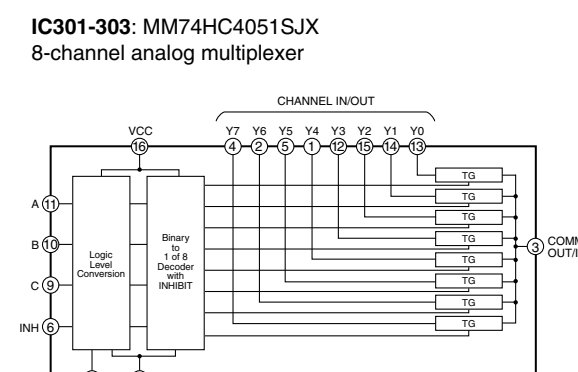

\* All voltages are measured with a 10MΩ/V DC electronic voltmeter.  
 \* Components having special characteristics are marked with a triangle and must be replaced with parts having specifications equal to those originally installed.  
 \* Schematic diagram is subject to change without notice.

VIDEO 2/2

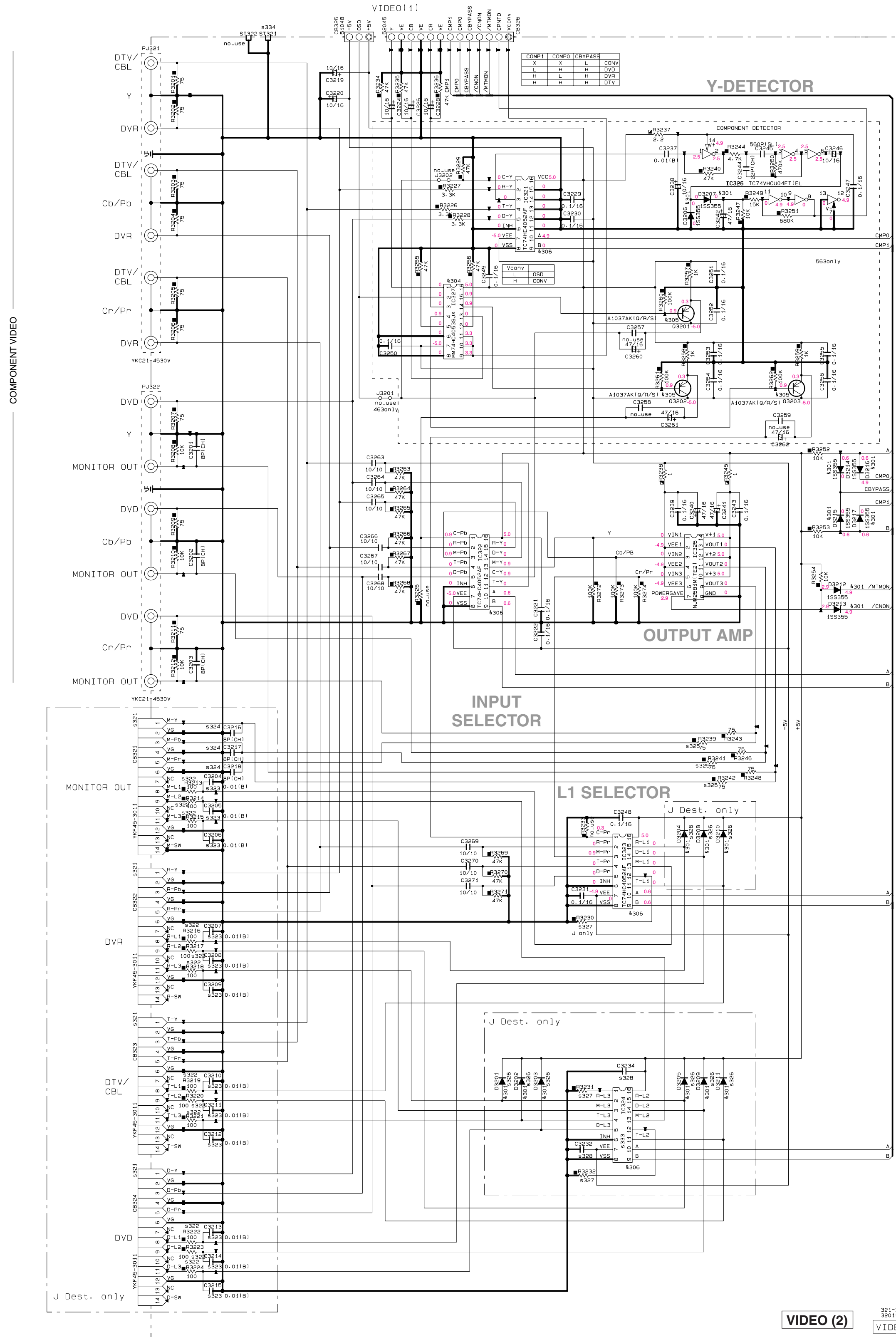

VIDEO (3)

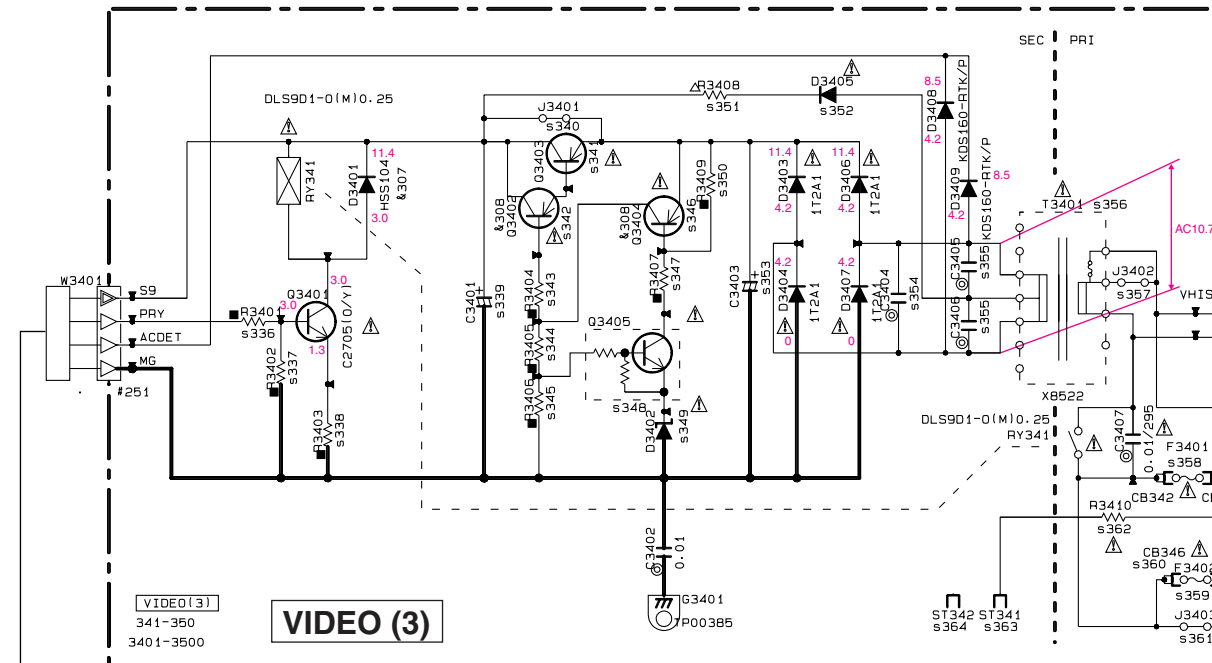

VIDEO (4)

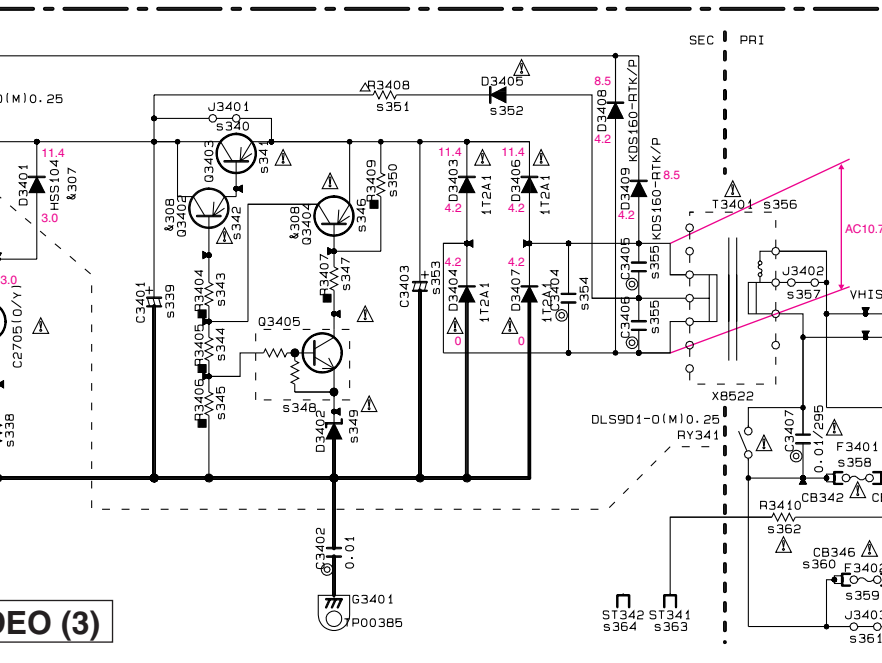

VIDEO (5)

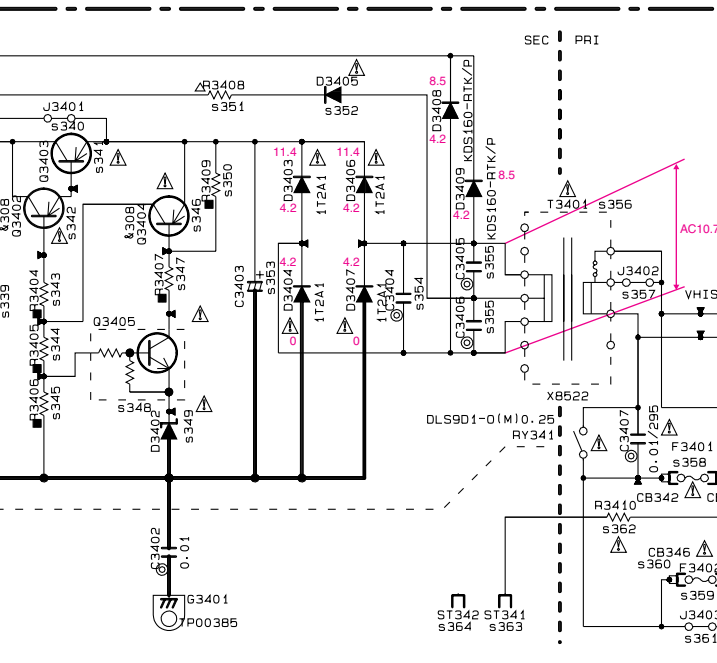

VIDEO (6)

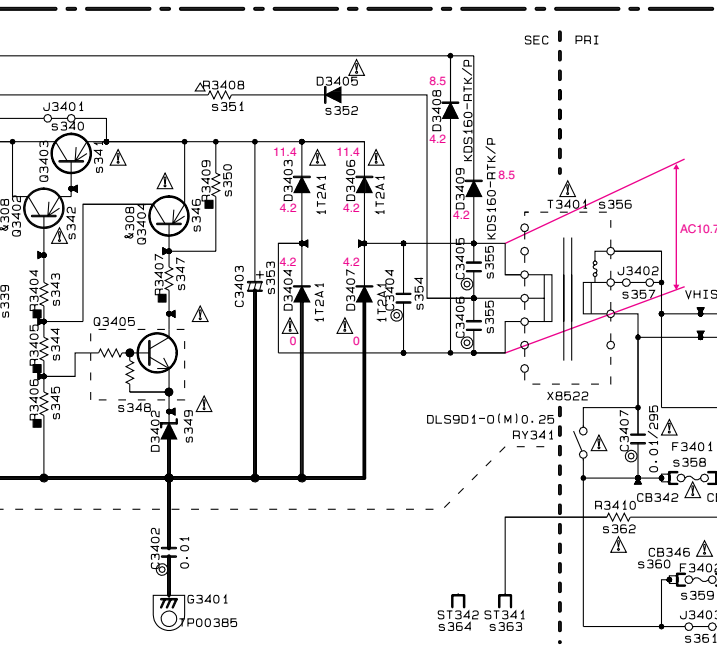

RESISTOR	PARTS NAME	CAPACITOR	PARTS NAME
NO MARK	CARBON FILM RESISTOR (P=5)	NO MARK	ELECTROLYTIC CAPACITOR
□	CARBON FILM RESISTOR (P=10)	□	TANTALUM CAPACITOR
△	METAL OXIDE FILM RESISTOR	⊙	CERAMIC TUBULAR CAPACITOR
⊙	METAL FILM RESISTOR	⊖	POLYESTER FILM CAPACITOR
⊘	METAL PLATE RESISTOR	Ⓛ	POLYSTYRENE FILM CAPACITOR
⊔	FIRE PROOF CARBON FILM RESISTOR	Ⓜ	MICA CAPACITOR
Ⓜ	CEMENT MOLDED RESISTOR	Ⓟ	POLYPROPYLENE FILM CAPACITOR
Ⓟ	SEMI VARIABLE RESISTOR	Ⓠ	SEMICONDUCTIVE CERAMIC CAPACITOR
■	CHIP RESISTOR		

DESTINATION PART LIST	IC	D	T	A	B	EFF	L
9301 XL301	W38040	W38040	W38040	W38040	W38040	W38040	W38040
9302 C3038	US06133	US06133	US06133	US06133	US06133	US06133	US06133
9303 C3039	US06133	US06133	US06133	US06133	US06133	US06133	US06133
9304 C3051	US06030	US06030	US06030	US06030	US06030	US06030	US06030
9301 CB321-CB324	W39840	W39840	W39840	W39840	W39840	W39840	W39840
9302 R3213-R3224	RD32010	RD32010	RD32010	RD32010	RD32010	RD32010	RD32010
9303 C3204-C3216	US06080	US06080	US06080	US06080	US06080	US06080	US06080
9304 R3239-R3241	RD32478	RD32478	RD32478	RD32478	RD32478	RD32478	RD32478
9305 C3201-C3205	US06080	US06080	US06080	US06080	US06080	US06080	US06080
9306 C3232	US13610	US13610	US13610	US13610	US13610	US13610	US13610
9307 C3240-C3246	US06040	US06040	US06040	US06040	US06040	US06040	US06040
9308 R3239-R3241	RD32478	RD32478	RD32478	RD32478	RD32478	RD32478	RD32478
9309 C3201-C3205	US06080	US06080	US06080	US06080	US06080	US06080	US06080
9310 C3204-C3216	US06080	US06080	US06080	US06080	US06080	US06080	US06080
9311 C3232	US13610	US13610	US13610	US13610	US13610	US13610	US13610
9312 IC324	TC74HC4052AF	TC74HC4052AF	TC74HC4052AF	TC74HC4052AF	TC74HC4052AF	TC74HC4052AF	TC74HC4052AF
9313 ST321	MA79960	MA79960	MA79960	MA79960	MA79960	MA79960	MA79960
9314 R3401	RD35647	RD35647	RD35647	RD35647	RD35647	RD35647	RD35647
9315 R3402	RD35647	RD35647	RD35647	RD35647	RD35647	RD35647	RD35647
9316 R3403	RD35647	RD35647	RD35647	RD35647	RD35647	RD35647	RD35647
9317 R3404	RD35647	RD35647	RD35647	RD35647	RD35647	RD35647	RD35647
9318 R3405	RD35647	RD35647	RD35647	RD35647	RD35647	RD35647	RD35647
9319 R3406	RD35647	RD35647	RD35647	RD35647	RD35647	RD35647	RD35647
9320 R3407	RD35647	RD35647	RD35647	RD35647	RD35647	RD35647	RD35647
9321 C3401	US06080	US06080	US06080	US06080	US06080	US06080	US06080
9322 C3402	US06080	US06080	US06080	US06080	US06080	US06080	US06080
9323 C3403	US06080	US06080	US06080	US06080	US06080	US06080	US06080
9324 C3404	US06080	US06080	US06080	US06080	US06080	US06080	US06080
9325 C3405	US06080	US06080	US06080	US06080	US06080	US06080	US06080
9326 F3401	VF4200	VF4200	VF4200	VF4200	VF4200	VF4200	VF4200
9327 F3402	VF4200	VF4200	VF4200	VF4200	VF4200	VF4200	VF4200
9328 R3401	RD35647	RD35647	RD35647	RD35647	RD35647	RD35647	RD35647
9329 R3402	RD35647	RD35647	RD35647	RD35647	RD35647	RD35647	RD35647
9330 R3403	RD35647	RD35647	RD35647	RD35647	RD35647	RD35647	RD35647
9331 R3404	RD35647	RD35647	RD35647	RD35647	RD35647	RD35647	RD35647
9332 R3405	RD35647	RD35647	RD35647	RD35647	RD35647	RD35647	RD35647
9333 R3406	RD35647	RD35647	RD35647	RD35647	RD35647	RD35647	RD35647
9334 R3407	RD35647	RD35647	RD35647	RD35647	RD35647	RD35647	RD35647
9335 C3401	US06080	US06080	US06080	US06080	US06080	US06080	US06080
9336 C3402	US06080	US06080	US06080	US06080	US06080	US06080	US06080
9337 C3403	US06080	US06080	US06080	US06080	US06080	US06080	US06080
9338 C3404	US06080	US06080	US06080	US06080	US06080	US06080	US06080
9339 C3405	US06080	US06080	US06080	US06080	US06080	US06080	US06080
9340 F3401	VF4200	VF4200	VF4200	VF4200	VF4200	VF4200	VF4200
9341 F3402	VF4200	VF4200	VF4200	VF4200	VF4200	VF4200	VF4200
9342 R3401	RD35647	RD35647	RD35647	RD35647	RD35647	RD35647	RD35647
9343 R3402	RD35647	RD35647	RD35647	RD35647	RD35647	RD35647	RD35647
9344 R3403	RD35647	RD35647	RD35647	RD35647	RD35647	RD35647	RD35647
9345 R3404	RD35647	RD35647	RD35647	RD35647	RD35647	RD35647	RD35647
9346 R3405	RD35647	RD35647	RD35647	RD35647	RD35647	RD35647	RD35647
9347 R3406	RD35647	RD35647	RD35647	RD35647	RD35647	RD35647	RD35647
9348 R3407	RD35647	RD35647	RD35647	RD35647	RD35647	RD35647	RD35647
9349 C3401	US06080	US06080	US06080	US06080	US06080	US06080	US06080
9350 C3402	US06080	US06080	US06080	US06080	US06080	US06080	US06080
9351 C3403	US06080	US06080	US06080	US06080	US06080	US06080	US06080
9352 C3404	US06080	US06080	US06080	US06080	US06080	US06080	US06080
9353 C3405	US06080	US06080	US06080	US06080	US06080	US06080	US06080
9354 F3401	VF4200	VF4200	VF4200	VF4200	VF4200	VF4200	VF4200
9355 F3402	VF4200	VF4200	VF4200	VF4200	VF4200	VF4200	VF4200
9356 R3401	RD35647	RD35647	RD35647	RD35647	RD35647	RD35647	RD35647
9357 R3402	RD35647	RD35647	RD35647	RD35647	RD35647	RD35647	RD35647
9358 R3403	RD35647	RD35647	RD35647	RD35647	RD35647	RD35647	RD35647
9359 R3404	RD35647	RD35647	RD35647	RD35647	RD35647	RD35647	RD35647
9360 R3405	RD35647	RD35647	RD35647	RD35647	RD35647	RD35647	RD35647
9361 R3406	RD35647	RD35647	RD35647	RD35647	RD35647	RD35647	RD35647
9362 R3407	RD35647	RD35647	RD35647	RD35647	RD35647	RD35647	RD35647
9363 C3401	US06080	US06080	US06080	US06080	US06080	US06080	US06080
9364 C3402	US06080	US06080	US06080	US06080	US06080	US06080	US06080
9365 C3403	US06080	US06080	US06080	US06080	US06080	US06080	US06080
9366 C3404	US06080	US06080	US06080	US06080	US06080	US06080	US06080
9367 C3405	US06080	US06080	US06080	US06080	US06080	US06080	US06080
9368 F3401	VF4200	VF4200	VF4200	VF4200	VF4200	VF4200	VF4200
9369 F3402	VF4200	VF4200	VF4200	VF4200	VF4200	VF4200	VF4200
9370 R3401	RD35647	RD35647	RD35647	RD35647	RD35647	RD35647	RD35647
9371 R3402	RD35647	RD35647	RD35647	RD35647	RD35647	RD35647	RD35647
9372 R3403	RD35647	RD35647	RD35647	RD35647	RD35647	RD35647	RD35647
9373 R3404	RD35647	RD35647	RD35647	RD35647	RD35647	RD35647	RD35647
9374 R3405	RD35647	RD35647	RD35647	RD35647	RD35647	RD35647	RD35647
9375 R3406	RD35647	RD35647	RD35647	RD35647	RD35647	RD35647	RD35647
9376 R3407	RD35647	RD35647	RD35647	RD35647	RD35647	RD35647	RD35647
9377 C3401	US06080	US06080	US06080	US06080	US06080	US06080	US06080
9378 C3402	US06080	US06080	US06080	US06080	US06080	US06080	US06080
9379 C3403	US06080	US06080	US06080	US06080	US06080	US06080	US06080
9380 C3404	US06080	US06080	US06080	US06080	US06080	US06080	US06080
9381 C3405	US06080	US06080	US06080	US06080	US06080	US06080	US06080
9382 F3401	VF4200	VF4200	VF4200	VF4200	VF4200	VF4200	VF4200
9383 F3402	VF4200	VF4200	VF4200	VF4200	VF4200	VF4200	VF4200
9384 R3401	RD35647	RD35647	RD35647	RD35647	RD35647	RD35647	RD35647
9385 R3402	RD35647	RD35647	RD35647	RD35647	RD35647	RD35647	RD35647
9386 R3403	RD35647	RD35647	RD35647	RD35647	RD35647	RD35647	RD35647
9387 R3404	RD35647	RD35647	RD35647	RD35647	RD35647	RD35647	RD35647

IC321-323: TC74HC4052AF Analog multiplexer/demultiplexer

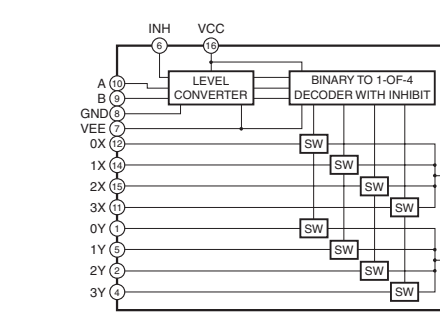

IC325: NJM2581M Video amplifier

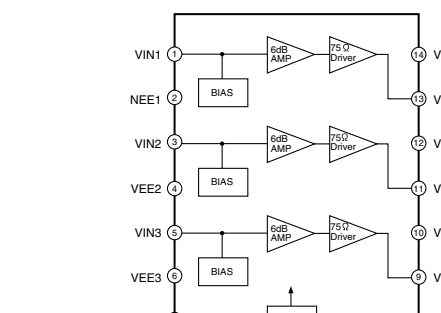

IC326: TC74VHC04FT Hex inverters

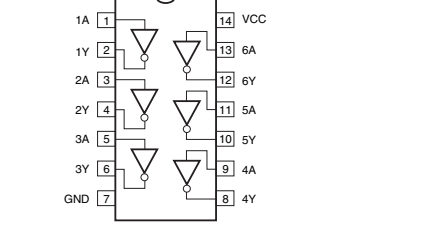

IC327: MM74HC4053JX Triple 2-channel analog multiplexer

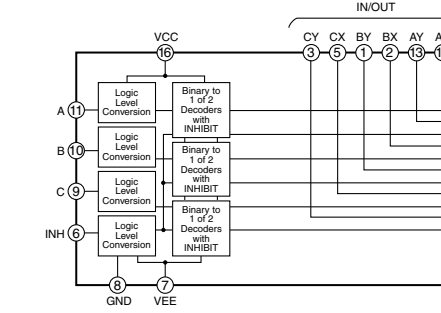

- NOTICE (mode1)  
(J)..... JAPAN  
(U)..... U.S.A  
(C)..... CANADA  
(E)..... GENERAL  
(T)..... CHINA  
(K)..... KOREA  
(A)..... AUSTRALIA  
(B)..... BRITISH  
(G)..... EUROPE  
(L)..... SINGAPORE  
(E)..... SOUTH EUROPE  
(Y)..... TAIWAN  
(F)..... RUSSIAN

\* All voltages are measured with a 10MΩ/V DC electronic voltmeter.  
\* Components having special characteristics are marked with a triangle and must be replaced with parts having specifications equal to those originally installed.  
\* Schematic diagram is subject to change without notice.



## ■ REPLACEMENT PARTS LIST

### • ELECTRICAL COMPONENT PARTS

#### WARNING

- Components having special characteristics are marked  $\triangle$  and must be replaced with parts having specifications equal to those originally installed.
- The chip resistor is not supplied as a replacement part.
  - \* When a chip resistor is necessary, use the following part.  
AAX60720: CHIP RESISTOR SAMPLE BOOK

#### ABBREVIATIONS IN THIS LIST ARE AS FOLLOWS:

C.A.EL.CHP	: CHIP ALUMI.ELECTROLYTIC CAP	L.EMIT	: LIGHT EMITTING MODULE
C.CE	: CERAMIC CAP	LED.DSPLY	: LED DISPLAY
C.CE.ARRAY	: CERAMIC CAP ARRAY	LED.INFRD	: LED,INFRARED
C.CE.CHP	: CHIP CERAMIC CAP	MODUL.RF	: MODULATOR,RF
C.CE.ML	: MULTILAYER CERAMIC CAP	PHOT.CPL	: PHOTO COUPLER
C.CE.M.CHP	: CHIP MULTILAYER CERAMIC CAP	PHOT.INTR	: PHOTO INTERRUPTER
C.CE.SAFTY	: RECOGNIZED CERAMIC CAP	PHOT.RFLCT	: PHOTO REFLECTOR
C.CE.TUBLR	: CERAMIC TUBULAR CAP	PIN.TEST	: PIN,TEST POINT
C.CE.SMI	: SEMI CONDUCTIVE CERAMIC CAP	PLST.RIVET	: PLASTIC RIVET
C.EL	: ELECTROLYTIC CAP	R.ARRAY	: RESISTOR ARRAY
C.MICA	: MICA CAP	R.CAR.	: CARBON RESISTOR
C.ML.FLM	: MULTILAYER FILM CAP	R.CAR.CHP	: CHIP RESISTOR
C.MP	: METALLIZED PAPER CAP	R.CAR.FP	: FLAME PROOF CARBON RESISTOR
C.MYLAR	: MYLAR FILM CAP	R.FUS	: FUSABLE RESISTOR
C.MYLAR.ML	: MULTILAYER MYLAR FILM CAP	R.MTL.CHP	: CHIP METAL FILM RESISTOR
C.PAPER	: PAPER CAPACITOR	R.MTL.FLM	: METAL FILM RESISTOR
C.PLS	: POLYSTYRENE FILM CAP	R.MTL.OXD	: METAL OXIDE FILM RESISTOR
C.POL	: POLYESTER FILM CAP	R.MTL.PLAT	: METAL PLATE RESISTOR
C.POLY	: POLYETHYLENE FILM CAP	RSNR.CE	: CERAMIC RESONATOR
C.PP	: POLYPROPYLENE FILM CAP	RSNR.CRYS	: CRYSTAL RESONATOR
C.TNTL	: TANTALUM CAP	R.TW.CEM	: TWIN CEMENT FIXED RESISTOR
C.TNTL.CHP	: CHIP TANTALUM CAP	R.CEMENT	: CEMENT RESISTOR
C.TRIM	: TRIMMER CAP	SCR.BND.HD	: BIND HEAD B-TIGHT SCREW
CN	: CONNECTOR	SCR.BW.HD	: BW HEAD TAPPING SCREW
CN.BS.PIN	: CONNECTOR,BASE PIN	SCR.CUP	: CUP TIGHT SCREW
CN.CANNON	: CONNECTOR,CANNON	SCR.TERM	: SCREW TERMINAL
CN.DIN	: CONNECTOR,DIN	SCR.TR	: SCREW,TRANSISTOR
CN.FLAT	: CONNECTOR,FLAT CABLE	SUPRT.PCB	: SUPPORT,P.C.B.
CN.POST	: CONNECTOR,BASE POST	SURG.PRTCT	: SURGE PROTECTOR
COIL.MX.AM	: COIL,AM MIX	SW.TACT	: TACT SWITCH
COIL.AT.FM	: COIL,FM ANTENNA	SW.LEAF	: LEAF SWITCH
COIL.DT.FM	: COIL,FM DETECT	SW.LEVER	: LEVER SWITCH
COIL.MX.FM	: COIL,FM MIX	SW.MICRO	: MICRO SWITCH
COIL.OUTPT	: OUTPUT COIL	SW.PUSH	: PUSH SWITCH
DIOD.ARRAY	: DIODE ARRAY	SW.RT.ENC	: ROTARY ENCODER
DIODE.BRG	: DIODE BRIDGE	SW.RT.MTR	: ROTARY SWITCH WITH MOTOR
DIODE.CHP	: CHIP DIODE	SW.RT	: ROTARY SWITCH
DIODE.VAR	: VARACTOR DIODE	SW.SLIDE	: SLIDE SWITCH
DIOD.Z.CHP	: CHIP ZENER DIODE	TERM.SP	: SPEAKER TERMINAL
DIODE.ZENR	: ZENER DIODE	TERM.WRAP	: WRAPPING TERMINAL
DSCR.CE	: CERAMIC DISCRIMINATOR	THRMST.CHP	: CHIP THERMISTOR
FER.BEAD	: FERRITE BEADS	TR.CHP	: CHIP TRANSISTOR
FER.CORE	: FERRITE CORE	TR.DGT	: DIGITAL TRANSISTOR
FET.CHP	: CHIP FET	TR.DGT.CHP	: CHIP DIGITAL TRANSISTOR
FL.DSPLY	: FLUORESCENT DISPLAY	TRANS	: TRANSFORMER
FLTR.CE	: CERAMIC FILTER	TRANS.PULS	: PULSE TRANSFORMER
FLTR.COMB	: COMB FILTER MODULE	TRANS.PWR	: POWER TRANSFORMER ASS'Y
FLTR.LC.RF	: LC FILTER,EMI	TUNER.AM	: TUNER PACK,AM
GND.MTL	: GROUND PLATE	TUNER.FM	: TUNER PACK,FM
GND.TERM	: GROUND TERMINAL	TUNER.PK	: FRONT-ENDTUNER PACK
HOLDER.FUS	: FUSE HOLDER	VR	: ROTARY POTENTIOMETER
IC.PRTCT	: IC PROTECTOR	VR.MTR	: POTENTIOMETER WITH MOTOR
JUMPER.CN	: JUMPER CONNECTOR	VR.SW	: POTENTIOMETER WITH ROTARY SW
JUMPER.TST	: JUMPER,TEST POINT	VR.SLIDE	: SLIDE POTENTIOMETER
L.DTCT	: LIGHT DETECTING MODULE	VR.TRIM	: TRIMMER POTENTIOMETER

P.C.B. DSP

\*  
\*  
\*  
\*  
\*  
\*  
\*  
\*  
\*

Ref. No.	Part No.	Description	Markets
	WN276000	P. C. B. DSP	UC
	WN276100	P. C. B. DSP	R
	WN276200	P. C. B. DSP	TA
	WN276300	P. C. B. DSP	K
	WN276400	P. C. B. DSP	B
	WN276500	P. C. B. DSP	GEF
	WN276600	P. C. B. DSP	L
CB11-13	WM462600	CN. HDMI 19P SE	
CB21	VQ047600	CN. BS. PIN 21P	
CB22	VM923600	CN. BS. PIN 13P	
CB31	VQ045500	CN. BS. PIN 26P	
CB32	VB390500	CN. BS. PIN 9P	
CB34	VQ044400	CN. BS. PIN 9P	
CB35	WJ458700	CN. XM 4P CAM-D96	UC
CB71	VB858500	CN. BS. PIN 6P	RTKABGEFL
CB81	VB390800	CN. BS. PIN 12P	
CB82	VB390200	CN. BS. PIN 6P	
CB83	VP127700	CN 24P	
CB84	VQ046000	CN. BS. PIN 31P	
C101-110	US135100	C. CE. CHP 0. 1uF 16V	
C111	WD758300	C. CE. CHP 10uF 10V	
C112	US135100	C. CE. CHP 0. 1uF 16V	
C113	US060900	C. CE. CHP 9pF 50V D	
C114	US060800	C. CE. CHP 8pF 50V B	
C115	US034820	C. CE. CHP 0. 082uF 16V K	
C116	US064100	C. CE. CHP 0. 01uF 50V B	
C117-136	US135100	C. CE. CHP 0. 1uF 16V	
C141	UR837100	C. EL 10uF 16V	
C142-143	US135100	C. CE. CHP 0. 1uF 16V	
C144	UR837100	C. EL 10uF 16V	
C145-146	US035100	C. CE. CHP 0. 1uF 16V B	
C147	US064100	C. CE. CHP 0. 01uF 50V B	
C148	US035100	C. CE. CHP 0. 1uF 16V B	
C151	US063820	C. CE. CHP 8200pF 50V B	
C152	US064100	C. CE. CHP 0. 01uF 50V B	
C153	WJ606100	C. MYLAR 0. 082uF 50V	
C154	US064100	C. CE. CHP 0. 01uF 50V B	
C156-157	WD758300	C. CE. CHP 10uF 10V	
C158	UR037100	C. EL 10uF 16V	
C159	US135100	C. CE. CHP 0. 1uF 16V	
C160	UR037100	C. EL 10uF 16V	
C161	WD758300	C. CE. CHP 10uF 10V	
C162	UR037100	C. EL 10uF 16V	
C163	WD758300	C. CE. CHP 10uF 10V	
C164	UR037100	C. EL 10uF 16V	
C165	US135100	C. CE. CHP 0. 1uF 16V	
C167	US062220	C. CE. CHP 220pF 50V B	
C169	US062220	C. CE. CHP 220pF 50V B	
C171-174	US064100	C. CE. CHP 0. 01uF 50V B	
C175-176	US035100	C. CE. CHP 0. 1uF 16V B	
C177	US061100	C. CE. CHP 10pF 50V B	
C178	US061150	C. CE. CHP 15pF 50V B	
C201-212	US062220	C. CE. CHP 220pF 50V B	
C213	UR037100	C. EL 10uF 16V	
C214-221	US635100	C. CE. CHP 0. 1uF 16V	
C222	US062100	C. CE. CHP 100pF 50V B	
C223-225	US035100	C. CE. CHP 0. 1uF 16V B	
C227-228	US135100	C. CE. CHP 0. 1uF 16V	
C229	UR237220	C. EL 22uF 16V	
C301	UR038100	C. EL 100uF 16V	

\* New Parts

Ref. No.	Part No.	Description	Markets
C302	US135100	C. CE. CHP 0. 1uF 16V	
C303-314	US062220	C. CE. CHP 220pF 50V B	
C315-316	UR037100	C. EL 10uF 16V	
C319	UR037100	C. EL 10uF 16V	
C320	US035100	C. CE. CHP 0. 1uF 16V B	
C321	UR067100	C. EL 10uF 50V	
C322-323	US126100	C. CE. CHP 1uF 10V	
C324	UU238100	C. EL 100uF 16V	
C325	US135100	C. CE. CHP 0. 1uF 16V	
C326	US064100	C. CE. CHP 0. 01uF 50V B	
C328-329	US061200	C. CE. CHP 20pF 50V B	
C330-331	US135100	C. CE. CHP 0. 1uF 16V	
C332	US061220	C. CE. CHP 22pF 50V B	
C334	US035100	C. CE. CHP 0. 1uF 16V B	
C335-338	US062220	C. CE. CHP 220pF 50V B	
C339	US064100	C. CE. CHP 0. 01uF 50V B	
C340-341	US062220	C. CE. CHP 220pF 50V B	
C342	US063100	C. CE. CHP 1000pF 50V B	
C343	US135100	C. CE. CHP 0. 1uF 16V	
C344	US135100	C. CE. CHP 0. 1uF 16V	RTKABGEFL
C345-346	US135100	C. CE. CHP 0. 1uF 16V	
C350-352	US062220	C. CE. CHP 220pF 50V B	
C353	US063100	C. CE. CHP 1000pF 50V B	UC
C354-357	US062220	C. CE. CHP 220pF 50V B	
C359	US135100	C. CE. CHP 0. 1uF 16V	
C360-365	US062220	C. CE. CHP 220pF 50V B	UC
C367	US062220	C. CE. CHP 220pF 50V B	UC
C368	US062220	C. CE. CHP 220pF 50V B	
C369-375	US135100	C. CE. CHP 0. 1uF 16V	
C376	US062220	C. CE. CHP 220pF 50V B	
C377	US035100	C. CE. CHP 0. 1uF 16V B	
C378	UR037100	C. EL 10uF 16V	
C379	UR237470	C. EL 47uF 16V	
C380	WJ606200	C. MYLAR 0. 1uF 50V	
C381	WJ605400	C. MYLAR 0. 022uF 50V J	
C382	US062220	C. CE. CHP 220pF 50V B	
C384	US135100	C. CE. CHP 0. 1uF 16V	
C385	US064100	C. CE. CHP 0. 01uF 50V B	
C386	US135100	C. CE. CHP 0. 1uF 16V	
C387	US126100	C. CE. CHP 1uF 10V	
C388	UR037100	C. EL 10uF 16V	
C389-391	US064100	C. CE. CHP 0. 01uF 50V B	
C401-408	UB446100	C. CE. CHP 1uF 16V	
C409-416	US635100	C. CE. CHP 0. 1uF 16V	
C417-418	US063100	C. CE. CHP 1000pF 50V B	
C419	US635100	C. CE. CHP 0. 1uF 16V	
C420-422	US063100	C. CE. CHP 1000pF 50V B	
C423-424	US635100	C. CE. CHP 0. 1uF 16V	
C425	US063100	C. CE. CHP 1000pF 50V B	
C426	US635100	C. CE. CHP 0. 1uF 16V	
C427-430	US063100	C. CE. CHP 1000pF 50V B	
C431-432	US061220	C. CE. CHP 22pF 50V B	
C433	US135100	C. CE. CHP 0. 1uF 16V	
C435-436	US135100	C. CE. CHP 0. 1uF 16V	
C437	WH771300	C. EL 100uF 10V	
C438	UB446100	C. CE. CHP 1uF 16V	
C439	US135100	C. CE. CHP 0. 1uF 16V	
C440	UB446100	C. CE. CHP 1uF 16V	
C441	WH771300	C. EL 100uF 10V	
C443	US062220	C. CE. CHP 220pF 50V B	

\* New Parts

RX-V563/HTR-6150/  
DSP-AX563

P.C.B. DSP

Ref. No.	Part No.	Description	Markets
C501-502	UB446100	C. CE. CHP 1uF 16V	
C503	US635100	C. CE. CHP 0.1uF 16V	
C504-505	US063100	C. CE. CHP 1000pF 50V B	
C506-507	US635100	C. CE. CHP 0.1uF 16V	
C508-509	US063100	C. CE. CHP 1000pF 50V B	
C510-517	US135100	C. CE. CHP 0.1uF 16V	
C519-520	US135100	C. CE. CHP 0.1uF 16V	
C521	US035100	C. CE. CHP 0.1uF 16V B	
C522	US135100	C. CE. CHP 0.1uF 16V	
C523	US061180	C. CE. CHP 18pF 50V B	
C524-525	US035100	C. CE. CHP 0.1uF 16V B	
C526-527	US135100	C. CE. CHP 0.1uF 16V	
C529	US035100	C. CE. CHP 0.1uF 16V B	
C530	UR038100	C. EL 100uF 16V	
C601-618	US635100	C. CE. CHP 0.1uF 16V	
C619	US135100	C. CE. CHP 0.1uF 16V	
C620	US062220	C. CE. CHP 220pF 50V B	
C621	UR837100	C. EL 10uF 16V	
C701-713	US135100	C. CE. CHP 0.1uF 16V	RTKABGEFL
C714	WD758300	C. CE. CHP 10uF 10V	RTKABGEFL
C715	US135100	C. CE. CHP 0.1uF 16V	RTKABGEFL
C716	WD758300	C. CE. CHP 10uF 10V	RTKABGEFL
C717-720	US135100	C. CE. CHP 0.1uF 16V	RTKABGEFL
C721	US062220	C. CE. CHP 220pF 50V B	RTKABGEFL
C722-723	US035100	C. CE. CHP 0.1uF 16V B	RTKABGEFL
C724-725	US064100	C. CE. CHP 0.01uF 50V B	RTKABGEFL
C726	US061120	C. CE. CHP 12pF 50V B	RTKABGEFL
C727	US061200	C. CE. CHP 20pF 50V B	RTKABGEFL
C729	UR838100	C. EL 100uF 16V	RTKABGEFL
C730-731	US064100	C. CE. CHP 0.01uF 50V B	RTKABGEFL
C801-862	US062220	C. CE. CHP 220pF 50V B	
C863	US063100	C. CE. CHP 1000pF 50V B	
C864	UR038470	C. EL 470uF 16V	
C865	US063100	C. CE. CHP 1000pF 50V B	
C866	UR238100	C. EL 100uF 16V	
C867	UB446100	C. CE. CHP 1uF 16V	
C868-870	US135100	C. CE. CHP 0.1uF 16V	
C871	UR038100	C. EL 100uF 16V	
C880	US062220	C. CE. CHP 220pF 50V B	
C881	US062100	C. CE. CHP 100pF 50V B	
C882-885	US062220	C. CE. CHP 220pF 50V B	
C886	US062470	C. CE. CHP 470pF 50V B	
C1301	US135100	C. CE. CHP 0.1uF 16V	UC
C1302-1303	US035100	C. CE. CHP 0.1uF 16V B	UC
C1304	US135100	C. CE. CHP 0.1uF 16V	UC
C1305	US063100	C. CE. CHP 1000pF 50V B	UC
C1306-1307	US061100	C. CE. CHP 10pF 50V B	UC
C1308-1309	UB446100	C. CE. CHP 1uF 16V	UC
C1310-1317	US135100	C. CE. CHP 0.1uF 16V	UC
C1318	UR237470	C. EL 47uF 16V	UC
C1319	US135100	C. CE. CHP 0.1uF 16V	UC
C1320	UR837100	C. EL 10uF 16V	UC
C1321	US064100	C. CE. CHP 0.01uF 50V B	
C1322	US035100	C. CE. CHP 0.1uF 16V B	UC
C1801-1827	US063100	C. CE. CHP 1000pF 50V B	
D109-111	WJ586300	VARI STOR SDV1608H100C050YPT	
D112	VT332900	DIODE 1SS355	
D113-116	WH641900	ESD PESD0603-140	
D117-118	WJ586300	VARI STOR SDV1608H100C050YPT	
D119-130	WH641900	ESD PESD0603-140	

\* New Parts

Ref. No.	Part No.	Description	Markets
D131-132	WJ586300	VARI STOR SDV1608H100C050YPT	
D135-136	WJ586300	VARI STOR SDV1608H100C050YPT	
D201	VT332900	DIODE 1SS355	
D305-306	VT332900	DIODE 1SS355	
D401	VS597600	DIODE. CHP RB160L-40 TE25	
D503	VT332900	DIODE 1SS355	
D801-802	VT332900	DIODE 1SS355	
D803-806	VU171400	DIODE. ZENR UDZS3.3BTE-17 3.3V	
D1301-1303	WJ586300	VARI STOR SDV1608H100C050YPT	UC
IC13	X7741A00	IC NJM2867F3-05 (TE1)	
IC21	X6671A00	IC ADV7172KSTZ	
IC22	X7907A00	IC NJM2845DL1-18	
IC31	X7746A00	IC LC89057W-VF4AD-E	
IC33-34	X6123A00	IC SN74LV157APWR	
IC36	X8192A00	IC F2621E-01-TR	UC
IC37	X7375A00	IC PCM1781DBQR	UC
IC38	X7355A00	IC PCM1680DBQR	
IC39	X7357A00	IC PCM1803DBR	
IC42	X8653A00	IC BR25L320F-W EEPROM	
IC43-44	XV894A00	IC TC74VHC153FT MULTI	
IC51	X9626A00	IC. MEMORY K4S641632K-UC60000	
IC52	X9636A00	IC. MEMORY EN29LV160AB-70TCP	(written)
IC53-55	XZ287A00	IC SN74LVC245APWR	
IC56	X9439A00	IC SN74AHCT574PWR	
IC57-59	X5135A00	IC SN74LV574APWR 8D-F	
IC61	X8813A00	IC MB87L8760	
IC62	X2709A00	IC SN74AHCT245PWR	
IC72	XZ287A00	IC SN74LVC245APWR	RTKABGEFL
IC73	X8096A00	IC R5523N001A-TR-F	RTKABGEFL
IC81	X6905A00	IC ADC084S021CIMM	
IC82-83	X5875A00	IC SN74LV4051APWR	
IC151	XZ287A00	IC SN74LVC245APWR	
IC152	X5405A00	IC SN74LVC32APWR OR	
IC153	X5404A00	IC SN74LVC08APWR AND	
IC154	X6611A00	IC SN74LV123APWR	
IC155	X6688A00	IC SN74LV14APWR INV	
JK31	VV269500	CN 8P DIN	UC
PJ31	V8795700	JACK. PIN 1P	
PN81-82	V9637500	PIN L=70 #18	
Q101-104	V0986700	TR 2SC4081 T106	
Q301	VV655200	TR. DGT DTA143EKA	UC
Q401	WE736300	FET RTQ040P02	
Q801	WE736300	FET RTQ040P02	
R217-218	WJ682800	R. MTL. FLM 2.2Ω 1W	
R328	HV753100	R. CAR. FP 1Ω 1/4W	
R1319	HV753100	R. CAR. FP 1Ω 1/4W	UC
T101	WA789600	SCR. TERM M3	
T301	WA789600	SCR. TERM M3	
U31	WH536900	CN. PHOTO. T 1P GP1FAV51TKOF	RTKABGEFL
U32-33	WH169900	CN. PHOTO. R 1P GP1FAV51RKOF	
XL31	WJ625200	RSNR. CRYST 24.576MHz	
XL101	VZ772700	RSNR. CRYST 28.63636MHz	
XL311	WH455300	RSNR. CRYST 45.1584MHz	UC
XL401	WB551700	RSNR. CRYST 16.666MHz SMD-49	
XL701	VS294900	RSNR. CRYST 12MHz SMD-49	RTKABGEFL

\* New Parts

RX-V563/HTR-6150/DSP-AX563

**P.C.B. OPERATION**

\*  
\*  
\*

Ref. No.	Part No.	Description	Markets
	WN278000	P. C. B. OPERATION	UC
	WN278100	P. C. B. OPERATION	RTKAGEFL
	WN278200	P. C. B. OPERATION	B
CB601-602	VB858300	CN. BS. PIN	
CB603	VP798200	CN. BS. PIN	
CB607	WG668100	CN. USB	RTKABGEFL
CB608	VB858400	CN. BS. PIN	
CB609	VB858200	CN. BS. PIN	
CB610	VB390300	CN. BS. PIN	
CB700	VB858300	CN. BS. PIN	
CB701	VB858600	CN. BS. PIN	
CB702	LB919110	CN. BS. PIN	
CB703	VK024700	CN. BS. PIN	
C6001	US063100	C. CE. CHP	1000pF 50V B
C6002	WJ605000	C. MYLAR	0.01uF 50V J
C6003-6004	US063100	C. CE. CHP	1000pF 50V B
C6005	WJ605000	C. MYLAR	0.01uF 50V J
C6006	US064100	C. CE. CHP	0.01uF 50V B
C6007	UM397100	C. EL	10uF 16V
C6008	UM397220	C. EL	22uF 25V
C6009-6010	WJ605000	C. MYLAR	0.01uF 50V J
C6011	US062100	C. CE. CHP	100pF 50V B
C6012	UM387470	C. EL	47uF 16V
C6013	US061330	C. CE. CHP	33pF 50V B
C6014	US135100	C. CE. CHP	0.1uF 16V
C6015	UM397100	C. EL	10uF 16V
C6016-6017	UM397220	C. EL	22uF 25V
C6018-6019	US135100	C. CE. CHP	0.1uF 16V
C6020	UR868100	C. EL	100uF 50V
C6021	UM388330	C. EL	330uF 6.3V
C6022	US135100	C. CE. CHP	0.1uF 16V
C6023	US061680	C. CE. CHP	68pF 50V B
C6024	US065100	C. CE. CHP	0.1uF 50V B
C6025-6026	US135100	C. CE. CHP	0.1uF 16V
C6027	US064100	C. CE. CHP	0.01uF 50V B
C6028	UM397100	C. EL	10uF 16V
C6029	US135100	C. CE. CHP	0.1uF 16V
C6030-6031	US062100	C. CE. CHP	100pF 50V B
C6032	US063100	C. CE. CHP	1000pF 50V B
C6033	US061100	C. CE. CHP	10pF 50V B
C6034	US135100	C. CE. CHP	0.1uF 16V
C6035	US063100	C. CE. CHP	1000pF 50V B
C6036	US135100	C. CE. CHP	0.1uF 16V
C6037-6038	US044220	C. CE. CHP	0.022uF 25V B
C6039	US064100	C. CE. CHP	0.01uF 50V B
C6040-6041	US044220	C. CE. CHP	0.022uF 25V B
C6042-6043	US135100	C. CE. CHP	0.1uF 16V UC
C6044-6045	US063680	C. CE. CHP	6800pF 50V B UC
C6047	US062100	C. CE. CHP	100pF 50V B RTKABGEFL
C6048-6049	US135100	C. CE. CHP	0.1uF 16V RTKABGEFL
C6050-6051	US062220	C. CE. CHP	220pF 50V B RTKABGEFL
C6060	US135100	C. CE. CHP	0.1uF 16V UC
C6063	US062470	C. CE. CHP	470pF 50V B
C6064	US126100	C. CE. CHP	1uF 10V RTKABGEFL
C6080-6081	US063100	C. CE. CHP	1000pF 50V B
C6082	US135100	C. CE. CHP	0.1uF 16V
C7000	UR866100	C. EL	1uF 50V
C7001	US135100	C. CE. CHP	0.1uF 16V
C7002-7003	UR837470	C. EL	47uF 16V
C7004	US064100	C. CE. CHP	0.01uF 50V B

\* New Parts

Ref. No.	Part No.	Description	Markets
C7005	UR866100	C. EL	1uF 50V
C7006-7007	US135100	C. CE. CHP	0.1uF 16V
C7008	UR866100	C. EL	1uF 50V
C7009	US135100	C. CE. CHP	0.1uF 16V
C7010	UR866100	C. EL	1uF 50V
C7011	UR837470	C. EL	47uF 16V
C7012-7014	US135100	C. CE. CHP	0.1uF 16V
C7015-7016	UR866100	C. EL	1uF 50V
C7017	UR837100	C. EL	10uF 16V
C7018	UR837470	C. EL	47uF 16V
C7019-7021	UR866100	C. EL	1uF 50V
C7022	US135100	C. CE. CHP	0.1uF 16V
C7023	UR73A100	C. EL	10000uF 16V
C7024	UR749470	C. EL	4700uF 25V
C7025	UR749220	C. EL	2200uF 25V
C7026	UR039470	C. EL	4700uF 16V
C7027	WG602000	C. EL	15000uF 16V
C7028	UR73A100	C. EL	10000uF 16V
C7029	WG602000	C. EL	15000uF 16V
C7030-7032	VE326000	C. MYLAR	0.1uF 50V
C7033	US135100	C. CE. CHP	0.1uF 16V
C7034-7035	WJ605000	C. MYLAR	0.01uF 50V J
C7036	VE326000	C. MYLAR	0.1uF 50V
C7037	WJ605000	C. MYLAR	0.01uF 50V J
D6001-6002	VT332900	DIODE	1SS355
D6003	VU172500	DIODE. ZENR	UDZS9.1B
D6004	VT332900	DIODE	1SS355
D6005	VU171900	DIODE. ZENR	UDZ5.1B 5.1V
D6006	VT332900	DIODE	1SS355
D6007-6009	WJ249600	LED	ORANGE
D6010-6011	VT332900	DIODE	1SS355 UCRTKAGEFL
D6011	VT332900	DIODE	1SS355
D6012	WJ249600	LED	ORANGE
D6013-6014	VT332900	DIODE	1SS355
D6017-6018	VU171500	DIODE. ZENR	UDZ 3.6BTE-17 3.6V
D6019	V2598200	LED	S1R-505ST UCRTKAGEFL
D6020-6023	VT332900	DIODE	1SS355 UC
D6024-6027	VT332900	DIODE	1SS355 RTKABGEFL
D7004	VS997800	DIODE	1T2
D7005-7006	VT332900	DIODE	1SS355
D7008	VS997800	DIODE	1T2
D7010	VT332900	DIODE	1SS355
D7012	V2376600	DIODE. SHOT	RB500V-40 UC
D7013	VU171900	DIODE. ZENR	UDZ5.1B 5.1V
D7014-7015	WA653100	DIODE. BRG	KBP103G 1A 200V
D7016-7017	VT332900	DIODE	1SS355
D7018-7019	WJ286700	DIODE. BRG	RS403M 4A 140V
IC601	X7378A00	IC	NJM4565M(Te1)
IC603	X6386A00	IC	M66003-0131FP
IC700	X4419A00	IC	NJM2396F33 3.3V
IC701	X4928A00	IC	K1A7805API 5V
IC702	X4419A00	IC	NJM2396F33 3.3V
IC703	X4928A00	IC	K1A7805API 5V
IC704	X4153A00	IC	K1A7812API
IC705	X4154A00	IC	K1A7912PI
IC706	X6143A00	IC	NJM2388F05 5.0V
IC707	X7976A00	IC	NJM2388F63
IC708	X0515A00	IC	LM61C1Z THERMAL
JK601	WJ117300	JACK. PHONE	PHONES
JK602	V9408200	JACK. PHONE	MSJ-064-05B GR

\* New Parts

RX-V563/HTR-6150/  
DSP-AX563

## P.C.B. OPERATION and P.C.B. MAIN

Ref. No.	Part No.	Description	Markets
JK603	WJ117400	JACK. MNI	OPTIMIZER MIC UC
PJ601	WJ117500	JACK. PIN	3P UC
PJ602	WJ117500	JACK. PIN	3P
PJ602	WJ117500	JACK. PIN	3P RTKABGEFL
PN601	V9637500	PIN	L=70 #18
PN604	V9637500	PIN	L=70 #18
PN607-609	V9637500	PIN	L=70 #18
PN701	V9637500	PIN	L=70 #18
Q6001	VV556400	TR	2SC2412K Q, R, S
Q6002	WC434800	TR. DGT	KRA102S-RTK/P
Q6003	VV556500	TR	2SA1037K Q, R, S
Q6004	VV556400	TR	2SC2412K Q, R, S
Q6005	WC435000	TR. DGT	KRC102S-RTK
Q6006-6008	VV556400	TR	2SC2412K Q, R, S
Q6009	VV655400	TR. DGT	DTC114EKA UCRTKAGEFL
Q6010	WC434800	TR. DGT	KRA102S-RTK/P
Q6011	VV556500	TR	2SA1037K Q, R, S
Q6012	VV556500	TR	2SA1037K Q, R, S UCRTKAGEFL
Q6012	VV556500	TR	2SA1037K Q, R, S
Q6014	WC435000	TR. DGT	KRC102S-RTK
Q6016	WC397700	TR	2N5401C-AT
Q6017-6018	VV556400	TR	2SC2412K Q, R, S
Q6029-6030	VV556400	TR	2SC2412K Q, R, S
Q7000	WC435100	TR. DGT	KRC104S-RTK
Q7001	VV556400	TR	2SC2412K Q, R, S
Q7002	WC435100	TR. DGT	KRC104S-RTK
R6001-6002	WJ685600	R. MTL. FLM	470 $\Omega$ 1W J
R7013	HV753100	R. CAR. FP	1 $\Omega$ 1/4W
R7019-7021	HV753100	R. CAR. FP	1 $\Omega$ 1/4W
R7025	WH820300	R. FUSE	1 $\Omega$ 1W J
R7029	WJ681400	R. MTL. FLM	0.15 $\Omega$ 1W
R7031	WJ681400	R. MTL. FLM	0.15 $\Omega$ 1W
ST601	WA789700	SCR. TERM	D3.5
ST602	WA789700	SCR. TERM	D3.5 RTKABGEFL
SW601-603	WD483100	SW. TACT	SKRGAAD010 UCRTKAGEFL
SW604-613	WD483100	SW. TACT	SKRGAAD010
SW614	V9597100	SW. RT. ENC	EC12E2460802
SW615-616	WD483100	SW. TACT	SKRGAAD010 UCRTKAGEFL
SW617-618	WD483100	SW. TACT	SKRGAAD010 UCRTKAGEFL
SW621-622	WD483100	SW. TACT	SKRGAAD010 UCRTKAGEFL
SW625-626	WD483100	SW. TACT	SKRGAAD010 UCRTKAGEFL
SW627	WD483100	SW. TACT	SKRGAAD010 UCRTKAGEFL
SW628	WD483100	SW. TACT	SKRGAAD010 UCRTKAGEFL
SW629	WD483100	SW. TACT	SKRGAAD010
U6001	WJ645300	L. DTCT	SM3385UMH6
V6001	WNO49000	FL. DSPLY	17-BT-32GNK
	WA790900	SPACER	4.6/10/32
	WN272300	P. C. B.	MAIN UCRTA
	WN272400	P. C. B.	MAIN KL
	WN272500	P. C. B.	MAIN B
	WN272600	P. C. B.	MAIN GEF
CB401	VQ048000	CN. BS. PIN	31P UCRTKAGEFL
CB402	VN520900	CN. BS. PIN	52045 26P TE
CB403	VM923600	CN. BS. PIN	13P UCRTKAGEFL
CB502	LB932060	CN. BS. PIN	6P
C4001	WJ605000	C. MYLAR	0.01 $\mu$ F 50V J
C4002	WJ603300	C. MYLAR	470pF 50V J

\* New Parts

Ref. No.	Part No.	Description	Markets
C4003	US064100	C. CE. CHP	0.01 $\mu$ F 50V B
C4005-4006	US061470	C. CE. CHP	47pF 50V B UCRTKAGEFL
C4008-4019	US062220	C. CE. CHP	220pF 50V B
C4020-4021	US061470	C. CE. CHP	47pF 50V B
C4022-4025	US062220	C. CE. CHP	220pF 50V B
C4026-4027	US061470	C. CE. CHP	47pF 50V B
C4028-4029	US062220	C. CE. CHP	220pF 50V B B
C4030-4033	UR837100	C. EL	10 $\mu$ F 16V UCRTKAGEFL
C4035-4036	UR837100	C. EL	10 $\mu$ F 16V UCRTKAGEFL
C4037	UR866220	C. EL	2.2 $\mu$ F 50V
C4038	UR866220	C. EL	2.2 $\mu$ F 50V
C4039	US135100	C. CE. CHP	0.1 $\mu$ F 16V
C4040-4041	UR067100	C. EL	10 $\mu$ F 50V
C4042-4043	UR847470	C. EL	47 $\mu$ F 25V
C4044-4045	UR038100	C. EL	100 $\mu$ F 16V
C4046-4047	UR837100	C. EL	10 $\mu$ F 16V UCRTKAGEFL
C4048	US063100	C. CE. CHP	1000pF 50V B
C4049-4050	US062100	C. CE. CHP	100pF 50V B
C4051	US064100	C. CE. CHP	0.01 $\mu$ F 50V B
C4052-4053	US062100	C. CE. CHP	100pF 50V B
C4054	WJ605400	C. MYLAR	0.022 $\mu$ F 50V J
C4055	WJ605800	C. MYLAR	0.047 $\mu$ F 50V J
C4056	VE326200	C. MYLAR	0.15 $\mu$ F 50V
C4057	UR837470	C. EL	47 $\mu$ F 16V
C4058	WJ605400	C. MYLAR	0.022 $\mu$ F 50V J
C4059-4066	UR837100	C. EL	10 $\mu$ F 16V
C4067	UR837470	C. EL	47 $\mu$ F 16V
C4068	VE326200	C. MYLAR	0.15 $\mu$ F 50V
C4069	US135100	C. CE. CHP	0.1 $\mu$ F 16V
C4070	WJ605800	C. MYLAR	0.047 $\mu$ F 50V J
C4071	UR837470	C. EL	47 $\mu$ F 16V
C4072	US135100	C. CE. CHP	0.1 $\mu$ F 16V GEF
C4073	UR038100	C. EL	100 $\mu$ F 16V
C4074-4081	UR067100	C. EL	10 $\mu$ F 50V
C4082	UR866220	C. EL	2.2 $\mu$ F 50V
C4083	US062330	C. CE. CHP	330pF 50V B GEF
C4084-4086	UR067100	C. EL	10 $\mu$ F 50V
C4087-4090	US162820	C. CE. CHP	820pF 50V J
C4091	WJ603600	C. MYLAR	820pF 50V J
C4092	WJ605400	C. MYLAR	0.022 $\mu$ F 50V J
C4093-4094	US162820	C. CE. CHP	820pF 50V J
C4095	US062330	C. CE. CHP	330pF 50V B GEF
C4096-4099	UR067100	C. EL	10 $\mu$ F 50V
C4100	US062100	C. CE. CHP	100pF 50V B
C4101-4105	US061820	C. CE. CHP	82pF 50V B
C4106	WJ604200	C. MYLAR	2700pF 50V
C4107-4108	US061820	C. CE. CHP	82pF 50V B
C4109	UR837470	C. EL	47 $\mu$ F 16V GEF
C4110-4118	UR837100	C. EL	10 $\mu$ F 16V
C4119-4120	US135100	C. CE. CHP	0.1 $\mu$ F 16V GEF
C4121	US062560	C. CE. CHP	560pF 50V B GEF
C4122	UR038100	C. EL	100 $\mu$ F 16V
C4123	UR837470	C. EL	47 $\mu$ F 16V GEF
C4124-4125	US061270	C. CE. CHP	27pF 50V B GEF
C4126	UR837470	C. EL	47 $\mu$ F 16V GEF
C4127-4128	UR038100	C. EL	100 $\mu$ F 16V
C5001	UR837330	C. EL	33 $\mu$ F 16V
C5002	WJ605000	C. MYLAR	0.01 $\mu$ F 50V J
C5003-5007	UR037100	C. EL	10 $\mu$ F 16V
C5008-5011	UR866220	C. EL	2.2 $\mu$ F 50V

\* New Parts

P.C.B. MAIN

Ref. No.	Part No.	Description	Markets
C5012-5013	UR037100	C. EL 10uF 16V	
C5014	WJ603300	C. MYLAR 470pF 50V J	
C5015	UR277220	C. EL 22uF 63V	
C5016	WJ603300	C. MYLAR 470pF 50V J	
C5017	UR297100	C. EL 10uF 100V	
C5018-5019	WJ603300	C. MYLAR 470pF 50V J	
C5020-5021	UR297100	C. EL 10uF 100V	
C5022	UR277220	C. EL 22uF 63V	
C5023-5025	UR297100	C. EL 10uF 100V	
C5026-5028	WJ603300	C. MYLAR 470pF 50V J	
C5029	WJ602900	C. MYLAR 100pF 50V K	
C5030	UR067330	C. EL 33uF 50V	
C5031	WJ602900	C. MYLAR 100pF 50V K	
C5032	UR067330	C. EL 33uF 50V	
C5033	WJ602900	C. MYLAR 100pF 50V K	
C5034-5035	UR067330	C. EL 33uF 50V	
C5036	WJ602900	C. MYLAR 100pF 50V K	
C5037	UR067330	C. EL 33uF 50V	
C5038	WJ602900	C. MYLAR 100pF 50V K	
C5039	UR067330	C. EL 33uF 50V	
C5040	WJ602900	C. MYLAR 100pF 50V K	
C5041	UR897100	C. EL 10uF 100V	
C5042	FG651100	C. CE 10pF 50V	
C5043	WJ602900	C. MYLAR 100pF 50V K	
C5044	UR067330	C. EL 33uF 50V	
C5045	UR866100	C. EL 1uF 50V	
C5046-5051	FG650500	C. CE 5pF 50V	
C5052-5058	WJ605800	C. MYLAR 0.047uF 50V J	
C5059	UR866470	C. EL 4.7uF 50V	
C5060	UR828220	C. EL 220uF 10V	
C5061	UR858100	C. EL 100uF 35V	
C5062	UR278100	C. EL 100uF 63V	
C5063	UR866470	C. EL 4.7uF 50V	
C5064	UR058100	C. EL 100uF 35V	
C5065-5066	WN524400	C. EL 6800uF 63V	
C5067-5076	WJ605000	C. MYLAR 0.01uF 50V J	
C5077-5078	WJ611400	C. MYLAR 0.1uF 100V J	
C5079	US064100	C. CE. CHP 0.01uF 50V B	
C5086-5087	WJ605400	C. MYLAR 0.022uF 50V J	
C5088-5089	UR837100	C. EL 10uF 16V	UCRTA
D4001-4002	VJ994300	DIODE. ZENR MA8075-H 7.7V	
D4003	VJ995500	DIODE. ZENR MA8100-H 10.3V	
D5001-5002	VD631600	DIODE 1SS133, 176	
D5003	VU171900	DIODE. ZENR UDZ5.1B 5.1V	
D5004	WC398800	DIODE KDS160-RTK	
D5005-5008	VN008700	DIODE 1SS270A	
D5009	WC398800	DIODE KDS160-RTK	
D5010-5012	VN008700	DIODE 1SS270A	
D5013	VD631600	DIODE 1SS133, 176	
D5014-5016	VN008700	DIODE 1SS270A	
D5017	VG441000	DIODE. ZENR MTZJ16A 16V	
D5018-5020	VD631600	DIODE 1SS133, 176	
D5021	WA653200	DIODE. BRG TS6P03G 6A 200V	
D5022-5023	VS997800	DIODE 1T2	
D5024	VD631600	DIODE 1SS133, 176	
D5025-5026	VN008700	DIODE 1SS270A	
D5027	VG441000	DIODE. ZENR MTZJ16A 16V	
IC401	X8155B00	IC R2A15218FP	
IC402	X8235A00	IC LC72725KM	GEF
IC403-407	X7378A00	IC NJM4565M(Te1)	

\* New Parts

Ref. No.	Part No.	Description	Markets
IC501	X8190A00	IC STK433-330-E	
IC502-503	X7427A00	IC STK433-130-E	
PJ401	V7190400	JACK. PIN 6P	
PJ402-403	V7046800	JACK. PIN 6P MSP-246V1-01NI	
PJ404	V7046700	JACK. PIN 4P MSP-244V1-01NI	B
PJ406	WC612700	JACK. PIN 2P	UCRTKAGEFL
PJ407	V7189700	JACK. PIN 1P	
PJ408	WC612700	JACK. PIN 2P	UCRTKAGEFL
PN501	V9637500	PIN L=70 #18	
Q4001	VZ725900	TR 2SD1938F S, T	
Q4002-4003	VZ725900	TR 2SD1938F S, T	UCRTKAGEFL
Q4004	VZ725900	TR 2SD1938F S, T	
Q4005-4006	VZ725900	TR 2SD1938F S, T	UCRTKAGEFL
Q4007	WC434800	TR. DGT KRA102S-RTK/P	UCRTKAGEFL
Q4008	WC434800	TR. DGT KRA102S-RTK/P	
Q4009	iC181510	TR 2SC1815 Y	
Q4010	iA101510	TR 2SA1015 Y	
Q4011	iC181510	TR 2SC1815 Y	
Q4012	iC174020	TR 2SC1740S ORS	GEF
Q5001-5007	VD303700	TR 2SC3326 A, B	
Q5008-5011	WC434800	TR. DGT KRA102S-RTK/P	
Q5012	WC398400	TR 2N5551C-AT	
Q5013-5014	VC614000	TR 2SB1274 Q, R, S	
Q5015	WC398400	TR 2N5551C-AT	
Q5016-5017	WC397700	TR 2N5401C-AT	
Q5018-5024	WC398400	TR 2N5551C-AT	
Q5025	WC397700	TR 2N5401C-AT	
Q5026-5029	WC434900	TR. DGT KRA104S-RTK	
Q5030	VP872600	TR 2SA1708 S, T	
Q5031	iC181510	TR 2SC1815 Y	
Q5032-5036	WC435000	TR. DGT KRC102S-RTK	
Q5037	WC434900	TR. DGT KRA104S-RTK	
R4080-4081	HV753220	R. CAR. FP 2.2Ω 1/4W	
R5035-5037	HV753220	R. CAR. FP 2.2Ω 1/4W	
R5040	HV755560	R. CAR. FP 560Ω 1/4W	
R5052	HV754100	R. CAR. FP 10Ω 1/4W	
R5055	HV754100	R. CAR. FP 10Ω 1/4W	
R5069	WM216400	R. WW 0.22Ω 3W (RF-3EGKR22)	
R5071-5072	WM216400	R. WW 0.22Ω 3W (RF-3EGKR22)	
R5079	WM216400	R. WW 0.22Ω 3W (RF-3EGKR22)	
R5083	WM216400	R. WW 0.22Ω 3W (RF-3EGKR22)	
R5090-5091	WM216400	R. WW 0.22Ω 3W (RF-3EGKR22)	
R5109	HV754100	R. CAR. FP 10Ω 1/4W	
R5112-5113	HV754100	R. CAR. FP 10Ω 1/4W	
R5115	HV754100	R. CAR. FP 10Ω 1/4W	
R5118	HV754100	R. CAR. FP 10Ω 1/4W	
R5121	HV754100	R. CAR. FP 10Ω 1/4W	
R5124	HV754100	R. CAR. FP 10Ω 1/4W	
R5126	WB625100	R. MTL. FLM 4.7Ω 1W J	
R5130-5131	WB625100	R. MTL. FLM 4.7Ω 1W J	
R5133-5134	WB625100	R. MTL. FLM 4.7Ω 1W J	
R5136-5137	WB625100	R. MTL. FLM 4.7Ω 1W J	
R5142	HV756270	R. CAR. FP 2.7KΩ 1/4W	
R5145	WB627300	R. MTL. OXD 470Ω 1W	
R5167-5168	HV753470	R. CAR. FP 4.7Ω 1/4W	
RY501-502	WJ122400	RELAY 981-2A-24DS-SP7	
RY504-505	WJ122400	RELAY 981-2A-24DS-SP7	
RY506	WJ117200	RELAY DC24V 942H-2C-24DS	
TE501	WK561000	TERM. SP 6P MST-207V1-01 NC	UCRTA
TE501	WK561100	TERM. SP 6P MST-207V1-01 WC	KBGEFL

\* New Parts

RX-V563/HTR-6150/  
DSP-AX563

**P.C.B. MAIN and P.C.B. VIDEO**

Ref. No.	Part No.	Description	Markets
TE502	WK560800	TERM. SP 4P MST-204V1-01 NC	UCRTA
TE502	WK560900	TERM. SP 4P MST-204V1-01 WC	KBGEFL
XL401	WJ588000	RSNR. CRYST 4. 332MHz	GEF
	WE774200	SCR. BND. HD 3x10 MFZN2W3	
	WN273300	P. C. B. VIDEO	UC
	WN273400	P. C. B. VIDEO	R
	WN273500	P. C. B. VIDEO	T
	WN273600	P. C. B. VIDEO	K
	WN273700	P. C. B. VIDEO	A
	WN273800	P. C. B. VIDEO	B
	WN273900	P. C. B. VIDEO	GEF
	WN274000	P. C. B. VIDEO	L
CB301	VB858200	CN. BS. PIN 3P	
CB303	VQ045100	CN. BS. PIN 21P	
CB326	VM923600	CN. BS. PIN 13P	
CB342-343	WN077700	CL. IP. FUSE CLIP PFC5000-0202F	
CB344-345	VG879900	CN. BS. PIN 2P	
CB346-347	WN077700	CL. IP. FUSE CLIP PFC5000-0202F	UCRTABGEFL
CB351	VB858400	CN. BS. PIN 5P	
CB353	LB919080	CN. BS. PIN 8P	
CB356	V9377800	CN. BS. PIN 3P	RL
CB357	V9377900	CN. BS. PIN 4P	RL
CB358-359	WN077700	CL. IP. FUSE CLIP PFC5000-0202F	RL
CB366	VB390000	CN. BS. PIN 4P	
C3001-3006	US062100	C. CE. CHP 100pF 50V B	
C3007-3008	WG218100	C. EL 100uF 16V	
C3009-3010	V7887800	C. EL 1uF 50V	
C3011-3014	US135100	C. CE. CHP 0. 1uF 16V	
C3015	UR837100	C. EL 10uF 16V	
C3016	US135100	C. CE. CHP 0. 1uF 16V	
C3017	UR837470	C. EL 47uF 16V	
C3018-3020	US135100	C. CE. CHP 0. 1uF 16V	
C3021	UR837470	C. EL 47uF 16V	
C3022	UR837100	C. EL 10uF 16V	
C3023-3024	US135100	C. CE. CHP 0. 1uF 16V	
C3026-3029	UR837470	C. EL 47uF 16V	
C3030-3031	UR838100	C. EL 100uF 16V	
C3032-3037	US135100	C. CE. CHP 0. 1uF 16V	
C3038	US061220	C. CE. CHP 22pF 50V B	UCRK
C3038	US060500	C. CE. CHP 5pF 50V B	TABGEFL
C3039	US061330	C. CE. CHP 33pF 50V B	UCRK
C3039	US060500	C. CE. CHP 5pF 50V B	TABGEFL
C3041	US135100	C. CE. CHP 0. 1uF 16V	
C3043	US135100	C. CE. CHP 0. 1uF 16V	
C3044-3045	UR837470	C. EL 47uF 16V	
C3048	UR866100	C. EL 1uF 50V	
C3049-3050	UR837470	C. EL 47uF 16V	
C3051	US060300	C. CE. CHP 3pF 50V B	UCRK
C3051	US060400	C. CE. CHP 4pF 50V B	TABGEFL
C3052-3053	US135100	C. CE. CHP 0. 1uF 16V	
C3054	US061240	C. CE. CHP 24pF 50V B	
C3055	US064100	C. CE. CHP 0. 01uF 50V B	
C3056	US135100	C. CE. CHP 0. 1uF 16V	
C3057	US061240	C. CE. CHP 24pF 50V B	
C3058	US062120	C. CE. CHP 120pF 50V B	
C3059	UR837470	C. EL 47uF 16V	
C3060	US062220	C. CE. CHP 220pF 50V B	

\* New Parts

Ref. No.	Part No.	Description	Markets
C3061-3065	US135100	C. CE. CHP 0. 1uF 16V	
C3066	US061100	C. CE. CHP 10pF 50V B	
C3067	UR837100	C. EL 10uF 16V	
C3068-3069	US135100	C. CE. CHP 0. 1uF 16V	
C3070	UR818470	C. EL 470uF 6. 3V	
C3071	US135100	C. CE. CHP 0. 1uF 16V	
C3072	UR837100	C. EL 10uF 16V	
C3073	US135100	C. CE. CHP 0. 1uF 16V	
C3074	UR837470	C. EL 47uF 16V	
C3075-3076	US135100	C. CE. CHP 0. 1uF 16V	
C3077-3078	UR837470	C. EL 47uF 16V	
C3079-3081	US135100	C. CE. CHP 0. 1uF 16V	
C3201-3203	US060800	C. CE. CHP 8pF 50V B	
C3219-3220	UR837100	C. EL 10uF 16V	
C3221-3222	US135100	C. CE. CHP 0. 1uF 16V	
C3224	UR837100	C. EL 10uF 16V	
C3226	UR837100	C. EL 10uF 16V	
C3228	UR837100	C. EL 10uF 16V	
C3229-3231	US135100	C. CE. CHP 0. 1uF 16V	
C3237	US064100	C. CE. CHP 0. 01uF 50V B	
C3238	UR837100	C. EL 10uF 16V	
C3239	US135100	C. CE. CHP 0. 1uF 16V	
C3240-3242	UR837470	C. EL 47uF 16V	
C3243	US135100	C. CE. CHP 0. 1uF 16V	
C3244	US061220	C. CE. CHP 22pF 50V B	
C3245	US062560	C. CE. CHP 560pF 50V B	
C3246	UR837100	C. EL 10uF 16V	
C3247-3256	US135100	C. CE. CHP 0. 1uF 16V	
C3260-3262	UR837470	C. EL 47uF 16V	
C3263-3271	WD758300	C. CE. CHP 10uF 10V	
C3401	UR749220	C. EL 2200uF 25V	UCTKABGEFL
C3401	UR759220	C. EL 2200uF 35V	RL
C3402	WJ605000	C. MYLAR 0. 01uF 50V J	
C3403	UR897100	C. EL 10uF 100V	RL
C3404	WJ605000	C. MYLAR 0. 01uF 50V J	UCTKABGEFL
C3405-3406	WJ605000	C. MYLAR 0. 01uF 50V J	RL
C3407	WB121400	C. CE. SAFETY 0. 01uF 295V	
C3501-3508	WJ605000	C. MYLAR 0. 01uF 50V J	
C3651	US063100	C. CE. CHP 1000pF 50V B	UCRTKAGEFL
C3652	US063100	C. CE. CHP 1000pF 50V B	
C3653	US064100	C. CE. CHP 0. 01uF 50V B	
C3654	US064100	C. CE. CHP 0. 01uF 50V B	UCRTKAGEFL
D3001-3002	VT332900	DIODE 1SS355	
D3206-3207	VT332900	DIODE 1SS355	
D3212-3217	VT332900	DIODE 1SS355	
D3401	VD631600	DIODE 1SS133, 176	
D3402	YG437000	DIODE. ZENR MTZJ4. 7A 4. 7V	RL
D3403-3404	VS997800	DIODE 1T2	
D3405	VS997800	DIODE 1T2	RL
D3406-3407	VS997800	DIODE 1T2	
D3408-3409	WC398800	DIODE KDS160-RTK	
D3501-3502	VD631600	DIODE 1SS133, 176	
D3651	VT332900	DIODE 1SS355	
D3652	VT332900	DIODE 1SS355	UCRTKAGEFL
F3401	WB221200	FUSE T6A 125V	UCRL
F3401	VV071700	FUSE 3. 15A 250V	TKABGEFL
F3402	WB221200	FUSE T6A 125V	UC
F3402	VT942900	FUSE T2. 5A 250V	RTABGEFL
F3551	VV071700	FUSE 3. 15A 250V	RL
IC301-303	XY550A00	IC MM74HC4051SJX	

\* New Parts

RX-V563/HTR-6150/DSP-AX563

P.C.B. VIDEO

Ref. No.	Part No.	Description	Markets
IC304	X7818A00	IC LC74782JM-8A16-TLM	
IC305	XZ509A00	IC TC74VHCU04FT INVER	
IC307	X6742A00	IC LA73050-TLM-E	
△ IC308	X4928A00	IC KIA7805API 5V	
△ IC309	X7973A00	IC KIA79M05PI-U	
IC310-311	XS790A00	IC TC74HC4052AF MPX	
IC321-323	XS790A00	IC TC74HC4052AF MPX	
IC325	X2904A00	IC NJM2581M VIDEO AMP	
IC326	XZ509A00	IC TC74VHCU04FT INVER	
IC327	XY877A00	IC MM74HC4053SJX	
JK301	VS867300	CN. DIN 4P YKF51-5501	
JK302-303	V9273500	CN. DIN 2P YKF51-5605	
JK366	V9435700	JACK. MNI MSJ-035-12APC	UCRTKAGEFL
JK367	V9435700	JACK. MNI MSJ-035-12APC	
JK368	V9435700	JACK. MNI MSJ-035-12APC	UCRTKAGEFL
PJ301	V7189800	JACK. PIN 1P	
PJ302-303	V7190000	JACK. PIN 2P	
PJ321-322	WG471900	JACK. PIN 6P	
PN351	V9637500	PIN L=70 #18	
PN366	V9637500	PIN L=70 #18	
Q3001-3003	VV556500	TR 2SA1037K Q, R, S	
Q3004-3005	VV556400	TR 2SC2412K Q, R, S	
Q3201-3203	VV556500	TR 2SA1037K Q, R, S	
△ Q3401	VE198800	TR 2SC2705 O, Y	
△ Q3402	iA101510	TR 2SA1015 Y	RL
△ Q3403	VP872600	TR 2SA1708 S, T	RL
△ Q3404	iA101510	TR 2SA1015 Y	RL
△ Q3405	WC529200	TR. DGT KRC102M-AT	RL
Q3501	WC398500	TR. DGT KRA102M-AT	
Q3502	WC529200	TR. DGT KRC102M-AT	
Q3503	WC398500	TR. DGT KRA102M-AT	
R3016	WB625900	R. MTL. OXD 33Ω 1W	
△ R3017	WB625800	R. MTL. OXD 27Ω 1W	
R3028-3029	HV753100	R. CAR. FP 1Ω 1/4W	
R3055	HV755470	R. CAR. FP 470Ω 1/4W	
R3056	HV753220	R. CAR. FP 2.2Ω 1/4W	
R3058	HV753100	R. CAR. FP 1Ω 1/4W	
R3060	WB625900	R. MTL. OXD 33Ω 1W	
R3237	HV753220	R. CAR. FP 2.2Ω 1/4W	
R3238	HV753100	R. CAR. FP 1Ω 1/4W	
R3245	HV753100	R. CAR. FP 1Ω 1/4W	
R3408	VC757900	R. MTL. OXD 47Ω 2W	RL
△ R3410	V6730000	R. CAR. 2.2MΩ 1/2W	UC
△ RY341	V9366900	RELAY DLS9D1-0(M) 0.25W	
RY351-352	WJ122400	RELAY 981-2A-24DS-SP7	
ST321	WA789600	SCR. TERM M3	UCRTKABGEFL
ST341	WA789600	SCR. TERM M3	UCK
ST342	WA789600	SCR. TERM M3	K
ST366-367	WA789600	SCR. TERM M3	
△ SW356	WB493700	VOLT. SELCT R8140246	R
△ SW356	WD073700	VOLT. SELCT R8140254	L
△ T3401	X8521A00	TRANS. PWR	UC
△ T3401	X8522A00	TRANS. PWR	RL
△ T3401	X8523A00	TRANS. PWR	T
△ T3401	X8523A00	TRANS. PWR	TKABGEF
△ TE341	WJ583000	AC. OUTLET 2P AC-182-UL	UC
△ TE341	V5867400	OUTLET. AC 2P	RT
△ TE341	VT915000	OUTLET. AC 1P	A
△ TE341	VU543300	OUTLET. AC 1P	B
△ TE341	VU543400	OUTLET. AC 2P	GEFL

\* New Parts

Ref. No.	Part No.	Description	Markets
* TE352	WNO45900	TERM. SCR 8P	UCRTA
* TE352	WNO46300	TERM. SCR 8P	KBGEFL
* XL301	WN380400	RSNR. CRY 14.3181MHz AT-49	UCRK
* XL301	WN380500	RSNR. CRY 17.7344MHz AT-49	TABGEFL

\* New Parts

RX-V563/HTR-6150/  
DSP-AX563



<b>Chip Resistors</b>
-----------------------

Value	1/4W Type Part No.	1/6W Type Part No.	Value	1/4W Type Part No.	1/6W Type Part No.
1.0 Ω	HJ35 3100	HF85 3100	10 kΩ	HF45 7100	HF45 7100
1.8 Ω	HJ35 3180	*	11 kΩ	HF45 7110	HF45 7110
2.2 Ω	HJ35 3220	HF85 3220	12 kΩ	HJ35 7120	HF85 7120
3.3 Ω	HJ35 3330	HF85 3330	13 kΩ	HF45 7130	HF45 7130
4.7 Ω	HJ35 3470	HF85 3470	15 kΩ	HF45 7150	HF45 7150
5.6 Ω	HJ35 3560	HF85 3560	18 kΩ	HF45 7180	HF45 7180
10 Ω	HF45 4100	HF45 4100	22 kΩ	HF45 7220	HF45 7220
15 Ω	HJ35 4150	HF85 4150	24 kΩ	HF45 7240	HF45 7240
22 Ω	HF45 4220	HF45 4220	27 kΩ	HJ35 7270	HF85 7270
27 Ω	HJ35 4270	HF85 4270	30 kΩ	HF45 7300	HF45 7300
33 Ω	HF45 4330	HF45 4330	33 kΩ	HF45 7330	HF45 7330
39 Ω	HJ35 4470	HF85 4390	36 kΩ	HF45 7360	HF45 7360
47 Ω	HF45 4470	HF45 4470	39 kΩ	HF45 7390	HF45 7390
56 Ω	HF45 4560	HF45 4560	47 kΩ	HF45 7470	HF45 7470
68 Ω	HF45 4680	HF45 4680	51 kΩ	HF45 7510	HF45 7510
75 Ω	HF45 4750	HF45 4750	56 kΩ	HF45 7560	HF45 7560
82 Ω	HF45 4820	HF45 4820	62 kΩ	HF45 7620	HF45 7620
91 Ω	HF45 4910	HF45 4910	68 kΩ	HF45 7680	HF45 7680
100 Ω	HF45 5100	HF45 5100	82 kΩ	HF45 7820	HF45 7820
110 Ω	HJ35 5110	HF85 5110	91 kΩ	HF45 7910	HF45 7910
120 Ω	HF45 5120	HF45 5120	100 kΩ	HF45 8100	HF45 8100
150 Ω	HF45 5150	HF45 5150	110 kΩ	HF45 8110	HF45 8110
160 Ω	HJ35 5160	*	120 kΩ	HF45 8120	HF45 8120
180 Ω	HF45 5180	HF45 5180	150 kΩ	HF45 8150	HF45 8150
200 Ω	HF45 5200	HF45 5200	180 kΩ	HF45 8180	HF45 8180
220 Ω	HF45 5220	HF45 5220	220 kΩ	HJ35 8220	HF85 8220
270 Ω	HF45 5270	HF45 5270	270 kΩ	HF45 8270	HF45 8270
330 Ω	HF45 5330	HF45 5330	300 kΩ	HF45 8300	HF45 8300
390 Ω	HF45 5390	HF45 5390	330 kΩ	HF45 8330	HF45 8330
430 Ω	HF45 5430	HF45 5430	390 kΩ	HJ35 8390	HF85 8390
470 Ω	HF45 5470	HF45 5470	470 kΩ	HF45 8470	HF45 8470
510 Ω	HF45 5510	HF45 5510	560 kΩ	HJ35 8560	HF85 8560
560 Ω	HF45 5560	HF45 5560	680 kΩ	HJ35 8680	HF85 8680
680 Ω	HF45 5680	HF45 5680	820 kΩ	HJ35 8820	HF85 8820
820 Ω	HF45 5820	HF45 5820	1.0 MΩ	HF45 9100	HF45 9100
910 Ω	HF45 5910	HF45 5910	1.2 MΩ	HJ35 9120	*
1.0 kΩ	HF45 6100	HF45 6100	1.5 MΩ	HJ35 9150	HF85 9150
1.2 kΩ	HF45 6120	HF45 6120	1.8 MΩ	HJ35 9180	HF85 9180
1.5 kΩ	HF45 6150	HF45 6150	2.2 MΩ	HJ35 9220	HF85 9220
1.8 kΩ	HF45 6180	HF45 6180	3.3 MΩ	HJ35 9330	HF85 9330
2.0 kΩ	HJ35 6200	HF85 6200	3.9 MΩ	HJ35 9390	*
2.2 kΩ	HF45 6220	HF45 6220	4.7 MΩ	HJ35 9470	HF85 9470
2.4 kΩ	HJ35 6240	HF85 6240			
2.7 kΩ	HF45 6270	HF45 6270			
3.0 kΩ	HF45 6300	HF45 6300			
3.3 kΩ	HF45 6330	HF45 6330			
3.6 kΩ	HJ35 6360	HF85 6360			
3.9 kΩ	HF45 6390	HF45 6390			
4.7 kΩ	HF45 6470	HF45 6470			
5.1 kΩ	HF45 6510	HF45 6510			
5.6 kΩ	HF45 6560	HF45 6560			
6.8 kΩ	HF45 6680	HF45 6680			
8.2 kΩ	HF45 6820	HF45 6820			
9.1 kΩ	HF45 6910	HF45 6910			

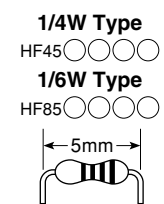
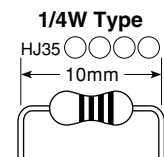

\* : Not available

• OVERALL ASS'Y

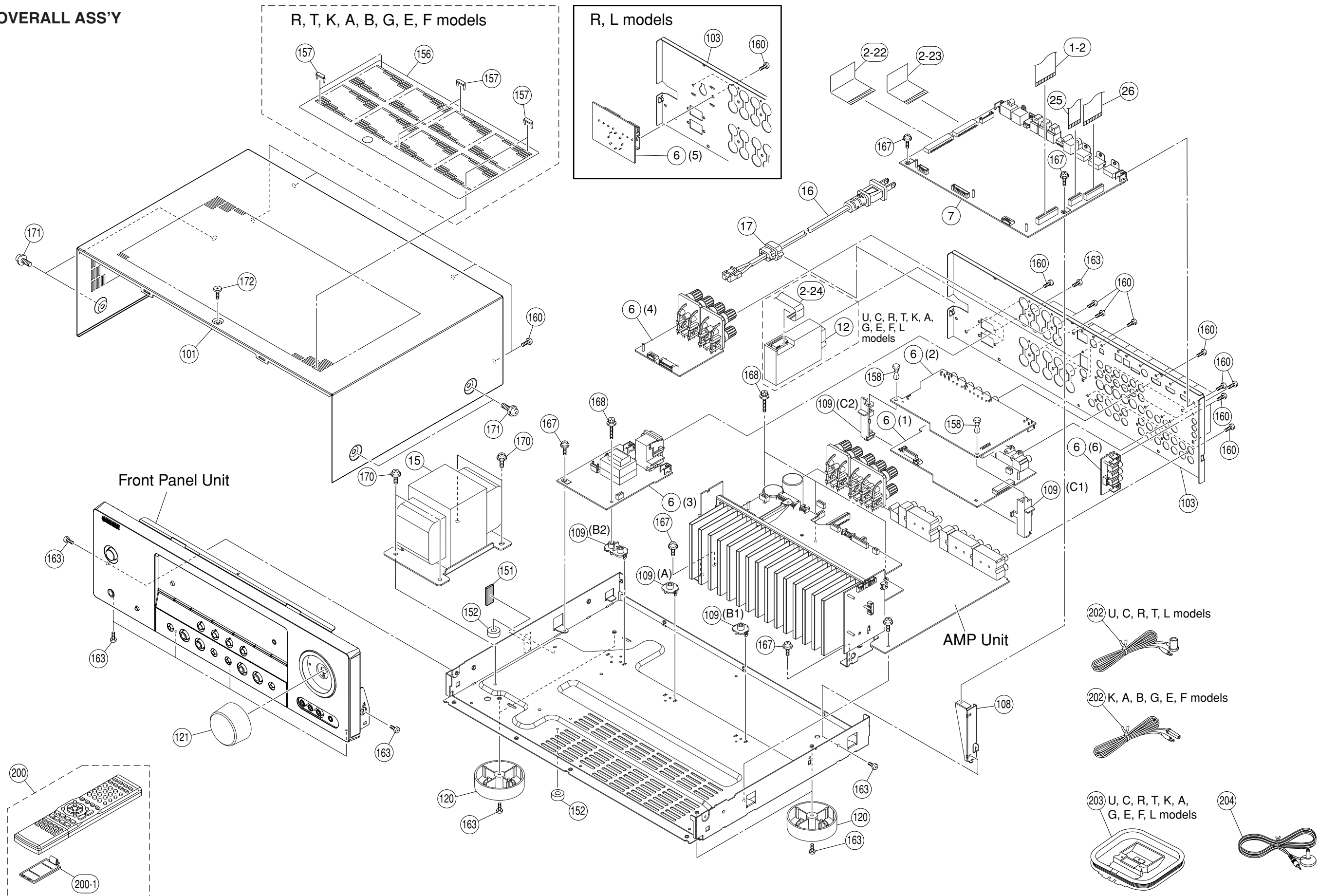

Ref. No.	Part No.	Description	Remarks	Markets
1-2	MF124250	FLEXIBLE FLAT CABLE	24P 250mm P=1.25	
2-22	MF131120	FLEXIBLE FLAT CABLE	31P 120mm P=1.25	
2-23	MF126100	FLEXIBLE FLAT CABLE	26P 100mm P=1.25	
2-24	MF113160	FLEXIBLE FLAT CABLE	13P 160mm P=1.25	
*	6	WN273300	P. C. B. ASS' Y	VIDEO UC
*	6	WN273400	P. C. B. ASS' Y	VIDEO R
*	6	WN273500	P. C. B. ASS' Y	VIDEO T
*	6	WN273600	P. C. B. ASS' Y	VIDEO K
*	6	WN273700	P. C. B. ASS' Y	VIDEO A
*	6	WN273800	P. C. B. ASS' Y	VIDEO B
*	6	WN273900	P. C. B. ASS' Y	VIDEO GEF
*	6	WN274000	P. C. B. ASS' Y	VIDEO L
*	7	WN276000	P. C. B. ASS' Y	DSP UC
*	7	WN276100	P. C. B. ASS' Y	DSP R
*	7	WN276200	P. C. B. ASS' Y	DSP TA
*	7	WN276300	P. C. B. ASS' Y	DSP K
*	7	WN276400	P. C. B. ASS' Y	DSP B
*	7	WN276500	P. C. B. ASS' Y	DSP GEF
*	7	WN276600	P. C. B. ASS' Y	DSP L
	12	WB424000	AM/FM TUNER	ENG06709Q UCRL
	12	WB877300	AM/FM TUNER	FAE381-A07F T
	12	WB424100	AM/FM TUNER	ENG07711Q KA
	12	WB877400	AM/FM TUNER	FAE481-E07F GEF
*	15	X9539A00	POWER TRANSFORMER	UC
*	15	X9540A00	POWER TRANSFORMER	RL
*	15	X9541A00	POWER TRANSFORMER	TK
*	15	X9542A00	POWER TRANSFORMER	A
*	15	X9543A00	POWER TRANSFORMER	BGEF
	16	WB120500	POWER CABLE	2m UC
	16	WC992700	POWER CABLE	2m R
	16	WB120600	POWER CABLE	2m T
	16	WC753000	POWER CABLE	2m K
	16	WC743700	POWER CABLE	2m A
	16	WB212200	POWER CABLE	2m B
	16	WB212300	POWER CABLE	2m GEFL
	17	V2438700	CORD STOPPER	10P1
	25	MF113100	FLEXIBLE FLAT CABLE	13P 100mm P=1.25
	26	MF121120	FLEXIBLE FLAT CABLE	21P 120mm P=1.25
*	101	WM744900	TOP COVER	GD
*	101	WM744800	TOP COVER	BL
*	101	WM745000	TOP COVER	TI
*	101	WM745100	TOP COVER	SI
*	103	WM745300	REAR PANEL	V563 UC
*	103	WM745500	REAR PANEL	V563 R
*	103	WM745600	REAR PANEL	V563 T
*	103	WM745700	REAR PANEL	V563 K
*	103	WM745800	REAR PANEL	V563 A
*	103	WM745900	REAR PANEL	AX563 B
*	103	WM746000	REAR PANEL	V563 GEF
*	103	WM746100	REAR PANEL	V563 L
*	103	WM746300	REAR PANEL	6150 UC
*	103	WM746800	REAR PANEL	6150 F
*	109	WM749300	SUPPORT PCB	
	120	WA790600	LEG	D60/H21 GD
	120	WA790500	LEG	D60/H21 HS
*	121	WM749500	KNOB D48	GD
*	121	WM749400	KNOB D48	BL
*	121	WM749600	KNOB D48	TI
*	121	WM749700	KNOB D48	SI

\* New Parts

Ref. No.	Part No.	Description	Remarks	Markets
151	WB408400	DAMPER	10x30 t=4	
152	WB484700	DAMPER	SCREW MASK	
156	WJ589800	SHEET TOP		RTKABGEF
157	WJ323900	RIVET TOP		RTKABGEF
158	VQ368600	PUSH RIVET	P3555-B	
160	WE774100	BIND HEAD BONDING B-T. SCREW	3x8 MFZN2B3	
163	WE774300	BIND HEAD B-TIGHT SCREW	3x8 MFZN2W3	
167	WF002600	PW HEAD B-TIGHT SCREW	3x8 MFZN2W3	
168	WE774600	SCREW IC	3x18 MFZN2W3	
170	WE774700	BIND HEAD S-TIGHT SCREW	4x10 MFZN2W3	
171	VD069600	PW HEAD S-TIGHT SCREW	4x8-10 MFN133	GD, TI, SI
171	VH313200	PW HEAD S-TIGHT SCREW	4x8-10 MFN13BL	BL
172	WE200400	DISH HEAD B-TIGHT SCREW	3x6 MFN133	GD, TI, SI
172	WE200500	DISH HEAD B-TIGHT SCREW	3x6 MFN13BL	BL
		ACCESSORIES		
*	200	WN057800	REMOTE CONTROL	RAV280 UC
*	200	WN058000	REMOTE CONTROL	RAV282 RTKABGEFL
	200-1	AAX82380	BATTERY COVER	CG-2209
	202	WB212500	INDOOR FM ANTENNA	1.4m 1pc UCRTL
	202	WB212400	INDOOR FM ANTENNA	1.4m 1pc KAGEF
	203	WB212600	AM LOOP ANTENNA	1.0m 1pc UCRTKAGEFL
*	204	WN649600	OPTIMIZER MICROPHONE BATTERY	6.0m 1pc EM6022L-HN1700
			R03, AAA, UM-4 2pcs	
		SERVICE TOOLS		

\* New Parts

• FRONT PANEL UNIT

U, C, R, T, K, A, G, E, F, L models

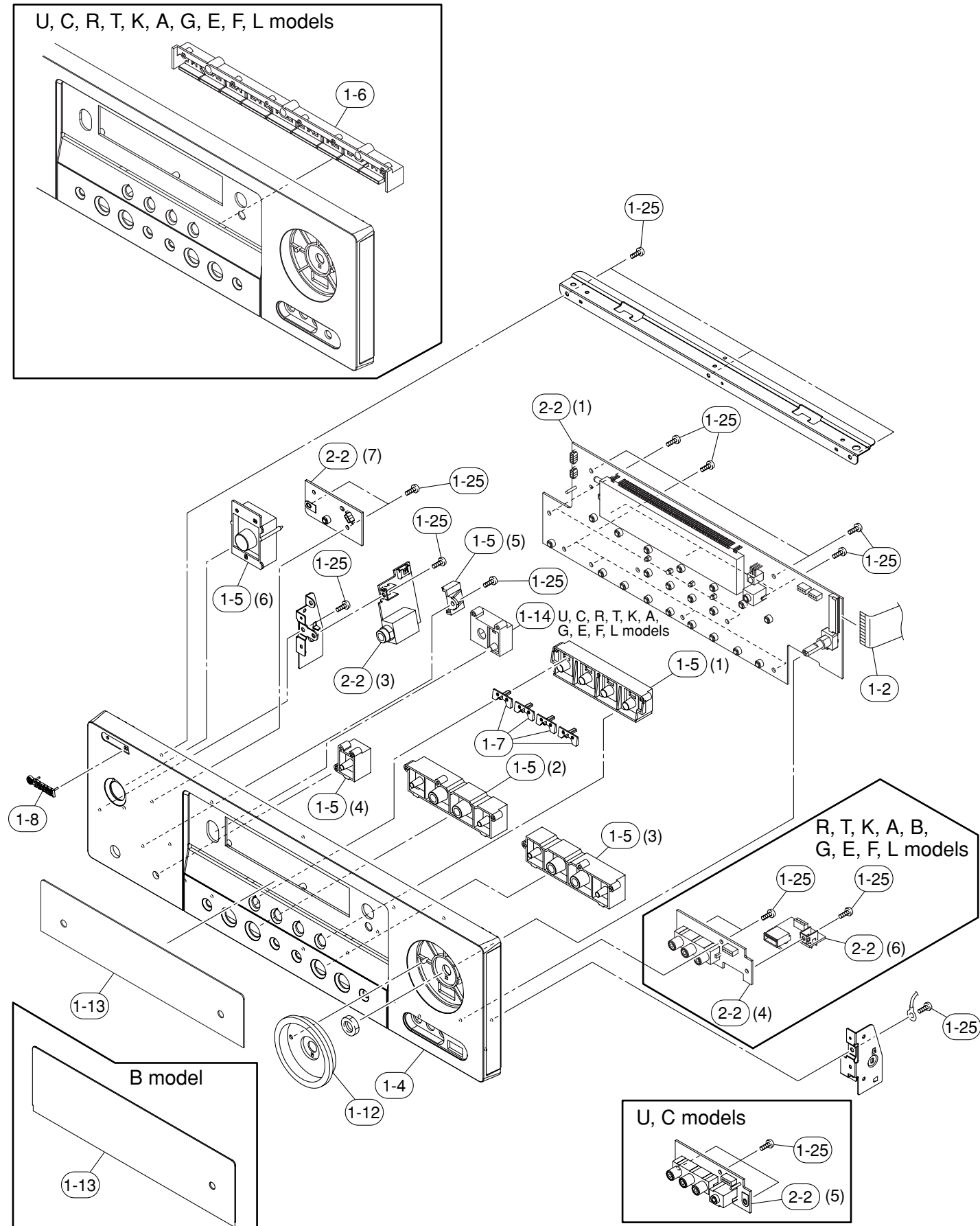

Ref. No.	Part No.	Description	Remarks	Markets
1-2	MF124250	FLEXIBLE FLAT CABLE	24P 250mm P=1.25	
* 1-4	WM752400	FRONT PANEL	GD	
* 1-4	WM751100	FRONT PANEL	V563BL	UC
* 1-4	WM751200	FRONT PANEL	V563BL	RAGEF
* 1-4	WM994500	FRONT PANEL	AX563BL	B
* 1-4	WM753600	FRONT PANEL	TI	KGEFL
* 1-4	WM994700	FRONT PANEL	TI	B
* 1-4	WM994800	FRONT PANEL	V563SI	
* 1-4	WM751400	FRONT PANEL	6150BL	UC
* 1-4	WM751500	FRONT PANEL	6150BL	F
* 1-4	WM754300	FRONT PANEL	6150SI	
* 1-5	WM808800	BUTTON CASE	GD	
* 1-5	WM808600	BUTTON CASE	BL	UCRAGEF
* 1-5	WJ192300	BUTTON CASE	BL	B
* 1-5	WM809000	BUTTON CASE	TI	KGEFL
* 1-5	WJ192700	BUTTON CASE	TI	B
* 1-5	WM808900	BUTTON CASE	SI	
* 1-6	WM749900	BUTTON TUNER		UCRTKAGEFL
* 1-7	WJ193200	LENS BUTTON	SCENE	
* 1-8	WJ193400	EMBLEM GD	GD	
* 1-8	WJ193300	EMBLEM BL	BL, TI, SI	
* 1-12	WM750100	ESCUTCHEON VOL	GD	
* 1-12	WM750000	ESCUTCHEON VOL	BL	
* 1-12	WM750200	ESCUTCHEON VOL	TI	
* 1-12	WM750300	ESCUTCHEON VOL	SI	
* 1-13	WM761200	SHEET WINDOW		UC
* 1-13	WM761300	SHEET WINDOW		RTKAGEFL
* 1-13	WM750400	SHEET WINDOW		B
* 1-14	WM749800	BUTTON SYSTEM OFF		UCRTKAGEFL
* 1-22	WA790900	SPACER FL	4, 6/10/32	
* 1-25	WE774800	BIND HEAD P-TIGHT SCREW	3x8 MFZN2W3	
* 1-26	WF268000	BIND HEAD P-TIGHT SCREW	3x10 MFZN2B3	RTKABGEFL
* 2-2	WN278000	P.C.B. ASS'Y	OPERATION	UC
* 2-2	WN278100	P.C.B. ASS'Y	OPERATION	RTKAGEFL
* 2-2	WN278200	P.C.B. ASS'Y	OPERATION	B

\* New Parts

• AMP UNIT

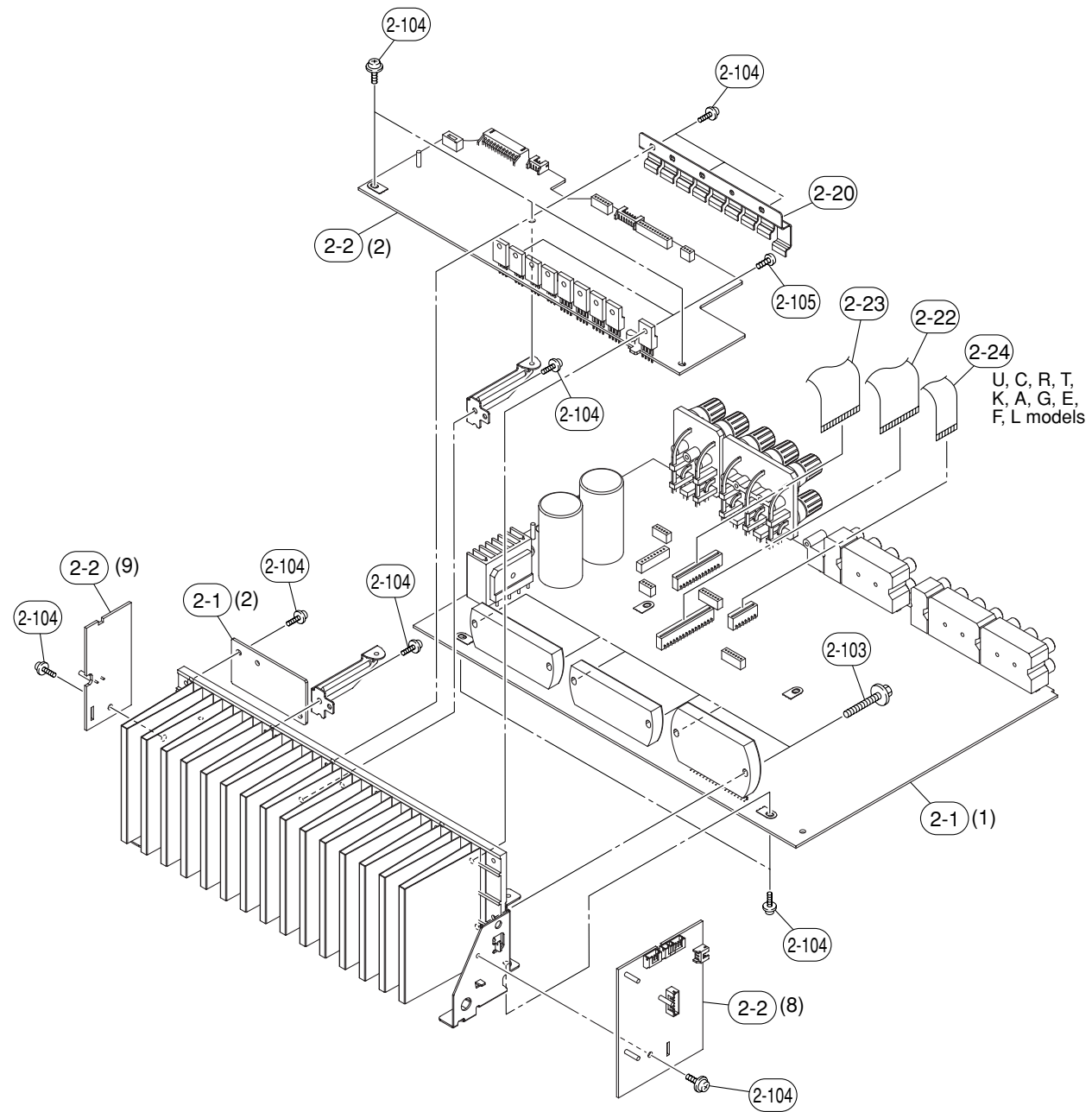

Ref. No.	Part No.	Description	Remarks	Markets	
*	2-1	WN272300	P. C. B. ASS'Y	MAIN	UCRTA
*	2-1	WN272400	P. C. B. ASS'Y	MAIN	KL
*	2-1	WN272500	P. C. B. ASS'Y	MAIN	B
*	2-1	WN272600	P. C. B. ASS'Y	MAIN	GEF
*	2-2	WN278000	P. C. B. ASS'Y	OPERATION	UC
*	2-2	WN278100	P. C. B. ASS'Y	OPERATION	RTKAGEFL
*	2-2	WN278200	P. C. B. ASS'Y	OPERATION	B
*	2-20	WM749200	SUPPORT TR-8P		
	2-22	MF131120	FLEXIBLE FLAT CABLE	31P 120mm P=1.25	
	2-23	MF126100	FLEXIBLE FLAT CABLE	26P 100mm P=1.25	
	2-24	MF113160	FLEXIBLE FLAT CABLE	13P 160mm P=1.25	UCRTKAGEFL
	2-103	WE774600	SCREW IC	3x18 MFZN2W3	
	2-104	WF002600	PW HEAD B-TIGHT SCREW	3x8 MFZN2W3	
	2-105	WE774300	BIND HEAD B-TIGHT SCREW	3x8 MFZN2W3	

\* New Parts

## ■ REMOTE CONTROL

● RAV280 (U, C models), RAV282 (R, T, K, A, B, G, E, F, L models)

• SCHEMATIC DIAGRAM

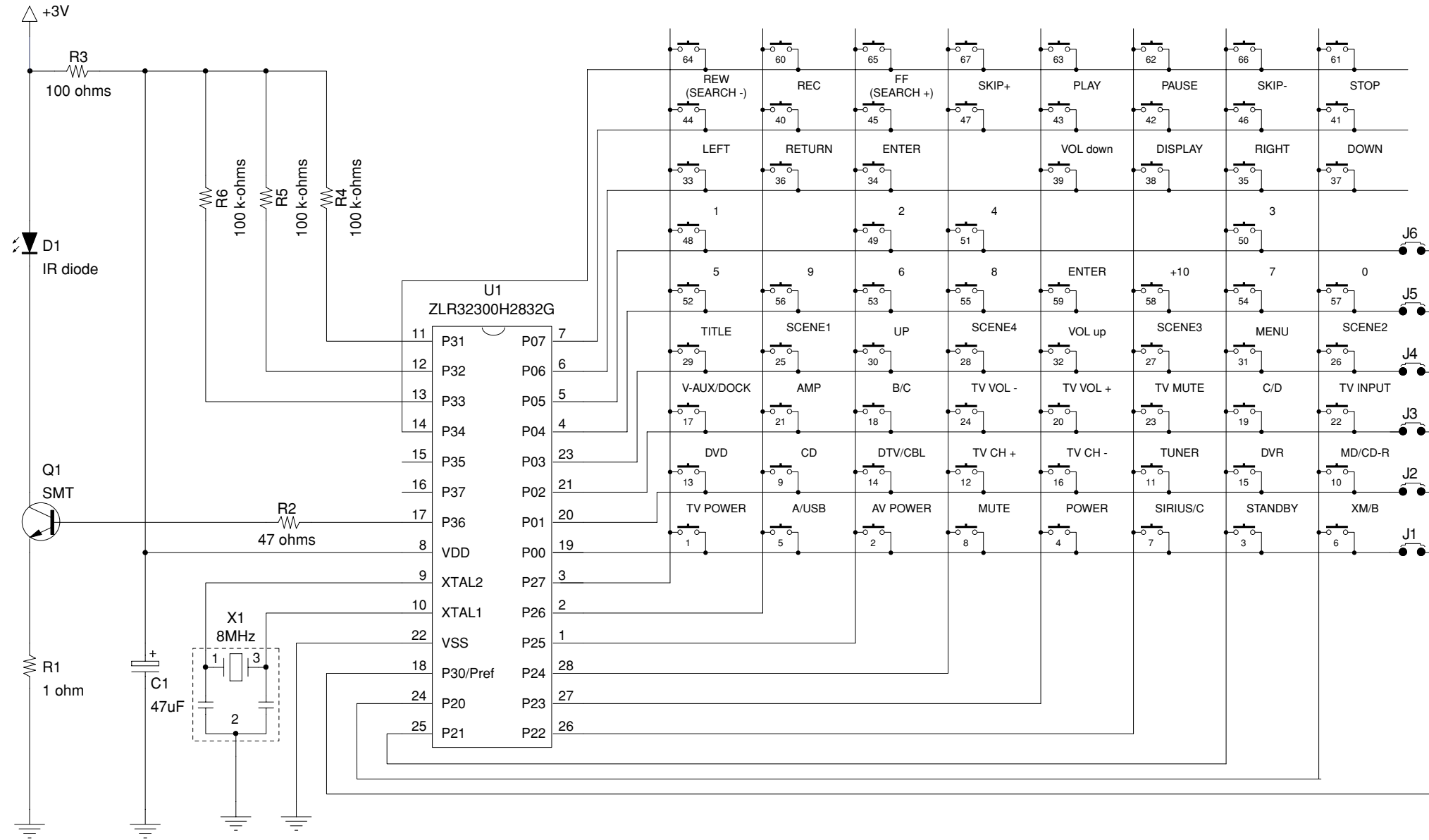

	RAV280	RAV282
J1	O	X
J2	X	X
J3	X	O
J4	X	X
J5	X	X
J6	X	X

• PANELS

RAV280  
(U, C models)

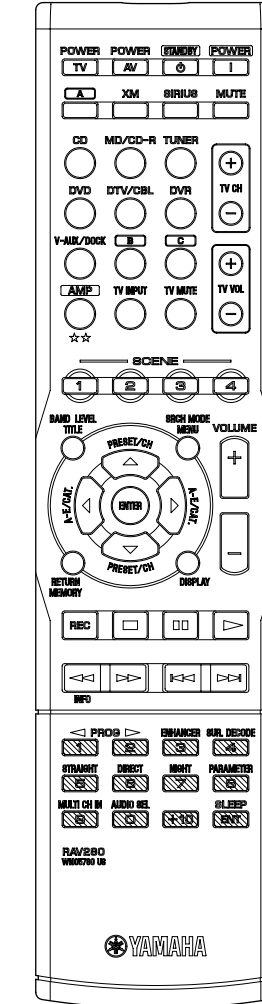

RAV282  
(R, T, K, A, B, G, E, F, L models)

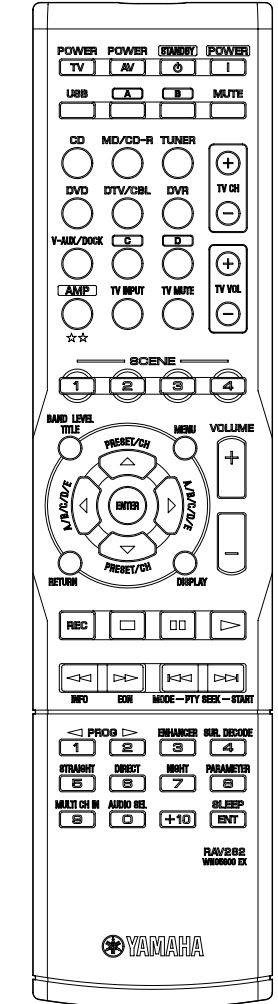

• KEY LAYOUT

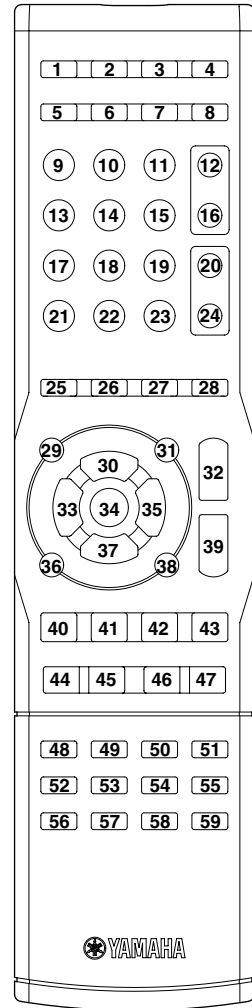

• IR CODE

Key no.	Label	Key		K21 [AMP]				K5	K6		K7		K9	K10	K11		K13	K14	K15	K17	K18	K19	
		Common	ZONE2 code	ID1 (default)		ID2		[USB] RAV282	[XM] RAV280	[SIRIUS] RAV280		[CD]	[MD/CD-R]	[TUNER]		[DVD]	[DVD/CBL]	[DVR]	[V-AUX]	[VCR]	[PHONO]		
				MAIN	ZONE2	MAIN	ZONE2		ID1 (default)	ID2	ID1 (default)	ID2			ID 1 (default)	ID2							
1	POWER TV	-	-	(TV POWER)				(TV POWER)	(TV POWER)	(TV POWER)	(TV POWER)	(TV POWER)	(TV POWER)	(TV POWER)	(TV POWER)	(TV POWER)	(TV POWER)	(TV POWER)	(TV POWER)	(TV POWER)	(TV POWER)	(TV POWER)	(TV POWER)
2	POWER AV	-	-	(device)				7F01-20	-	-	7F01-D0	7F01-D02E	79-60	7F-80	D1-1B	-	7C-80	(DVR POWER)	048.012	7F01-00	-	-	(DVR POWER)
3	STANDBY	O	O	7E-7F	7E-BB	7E-7F81	7E-BB45	-	-	-	-	-	-	-	-	-	-	-	-	-	-	-	
4	POWER	O	O	7E-7E	7E-BA	7E-7E80	7E-BA44	-	-	-	-	-	-	-	-	-	-	-	-	-	-	-	
5	A (RAV280, RAV281)	O	O	7F01-3F	7F01-40	7F01-3FC1	7F01-40BE	-	-	-	-	-	-	-	-	-	-	-	-	-	-	-	
6	USB (RAV282)	O	O	7A-B4	7A-B8	7A-B44A	7A-B846	-	-	-	-	-	-	-	-	-	-	-	-	-	-	-	
	XM (RAV280)																						
	B (RAV281)																						
7	A (RAV282)	O	O	7A-39	7A-3A	7A-39C7	7A-3AC4	-	-	-	-	-	-	-	-	-	-	-	-	-	-	-	
	SIRIUS (RAV280)																						
	C (RAV281)																						
8	B (RAV282)	O	O	7A-1C	7A-DC	7A-1CE2	7A-DC22	-	-	-	-	-	-	-	-	-	-	-	-	-	-	-	
	MUTE																						
	CD																						
9	MD/CD-R	O	O	7A-15	7A-D1	7A-15EB	7A-D12F	-	-	-	-	-	-	-	-	-	-	-	-	-	-	-	
10	TUNER	O	O	7A-C9	7A-CF	7A-C937	7A-CF31	-	-	-	-	-	-	-	-	-	-	-	-	-	-	-	
11	TV CH +	-	-	(TV CH +)				(TV CH +)	(TV CH +)	(TV CH +)	(TV CH +)	(TV CH +)	(TV CH +)	(TV CH +)	(TV CH +)	(TV CH +)	(TV CH +)	(TV CH +)	(TV CH +)	(TV CH +)	(TV CH +)	(TV CH +)	(TV CH +)
12	DVD	O	O	7A-C1	7A-CD	7A-C13F	7A-CD33	-	-	-	-	-	-	-	-	-	-	-	-	-	-	-	
13	DTV/CBL	O	O	7A-54	7A-D9	7A-54AA	7A-D927	-	-	-	-	-	-	-	-	-	-	-	-	-	-	-	
14	DVR	O	O	7A-13	7A-D7	7A-13ED	7A-D729	-	-	-	-	-	-	-	-	-	-	-	-	-	-	-	
15	TV CH -	-	-	(TV CH -)				(TV CH -)	(TV CH -)	(TV CH -)	(TV CH -)	(TV CH -)	(TV CH -)	(TV CH -)	(TV CH -)	(TV CH -)	(TV CH -)	(TV CH -)	(TV CH -)	(TV CH -)	(TV CH -)	(TV CH -)	(TV CH -)
16	V-AUX/DOCK	O	O	7A-55	7A-D8	7A-55AB	7A-D826	-	-	-	-	-	-	-	-	-	-	-	-	-	-	-	
17	B (RAV280)	O	O	7A-5F	7A-D6	7A-5FF1	7A-D628	-	-	-	-	-	-	-	-	-	-	-	-	-	-	-	
	D (RAV281)																						
	C (RAV282)																						
	C (RAV281)																						
18	E (RAV282)	O	O	7A-14	7A-D0	7A-14EA	7A-D02E	-	-	-	-	-	-	-	-	-	-	-	-	-	-	-	
	D (RAV283)																						
	TV VOL +																						
	AMP / ☆☆																						
19	TV INPUT	-	-	(TV INPUT)				(TV INPUT)	(TV INPUT)	(TV INPUT)	(TV INPUT)	(TV INPUT)	(TV INPUT)	(TV INPUT)	(TV INPUT)	(TV INPUT)	(TV INPUT)	(TV INPUT)	(TV INPUT)	(TV INPUT)	(TV INPUT)	(TV INPUT)	
20	TV MUTE	-	-	(TV MUTE)				(TV MUTE)	(TV MUTE)	(TV MUTE)	(TV MUTE)	(TV MUTE)	(TV MUTE)	(TV MUTE)	(TV MUTE)	(TV MUTE)	(TV MUTE)	(TV MUTE)	(TV MUTE)	(TV MUTE)	(TV MUTE)	(TV MUTE)	(TV MUTE)
21	TV VOL -	-	-	(TV VOL -)				(TV VOL -)	(TV VOL -)	(TV VOL -)	(TV VOL -)	(TV VOL -)	(TV VOL -)	(TV VOL -)	(TV VOL -)	(TV VOL -)	(TV VOL -)	(TV VOL -)	(TV VOL -)	(TV VOL -)	(TV VOL -)	(TV VOL -)	(TV VOL -)
22	SCENE 1	O	O	7A-007F	7A-017E	7A-007E	7A-017F	-	-	-	-	-	-	-	-	-	-	-	-	-	-	-	
23	SCENE 2	O	O	7A-037C	7A-047B	7A-037D	7A-047A	-	-	-	-	-	-	-	-	-	-	-	-	-	-	-	
24	SCENE 3	O	O	7A-0679	7A-0778	7A-0678	7A-0779	-	-	-	-	-	-	-	-	-	-	-	-	-	-	-	
25	SCENE 4	O	O	7A-0976	7A-0A75	7A-0977	7A-0A74	-	-	-	-	-	-	-	-	-	-	-	-	-	-	-	
26	BAND LEVEL / TITLE			7A-86	7A-8678			7F01-2D	7A-70	7A-708E	7F01-DD	7F01-DD23	-	-	7A-AE	7A-AE50	7C-B1	-	048.200	7F01-0D	-	-	
27	PRESET/CH ▲ (UP)			7A-9D	7A-9D63			7F01-2E	7A-6A	7A-6A94	7F01-E1	7F01-E11F	-	-	7A-10	7A-10EE	7C-B4	-	048.088	7F01-0E	-	-	
28	SRCH MODE / MENU			7A-84	7A-847A			7F01-2F	7A-6D	7A-6D93	7F01-DE	7F01-DE20	-	-	7A-AB	7A-AB55	7C-B2	-	048.084	7F01-0F	-	-	
29	VOLUME +	O	O	7A-1A	7A-DA	7A-1AE4	7A-DA24	-	-	-	-	-	-	-	-	-	-	-	-	-	-	-	
30	A-E/CAT. / A/B/C/D/E			7A-9F	7A-9F61			7F01-30	7A-6E	7A-6E90	7F01-E2	7F01-E21C	-	-	7A-AC	7A-AC52	7C-B5	-	048.090	7F01-10	-	-	
31	ENTER			7A-DE	7A-DE20			7F01-31	7A-6F	7A-6F91	7F01-E3	7F01-E31D	-	-	7A-AD	7A-AD53	7C-B8	-	048.092	7F01-11	-	-	
32	A-E/CAT. / A/B/C/D/E			7A-9E	7A-9E60			7F01-32	7A-6C	7A-6C92	7F01-E4	7F01-E41A	-	-	7A-12	7A-12EC	7C-B6	-	048.091	7F01-12	-	-	
33	RETURN / MEMORY			7A-AA	7A-AA54			7F01-33	7A-71	7A-718F	7F01-DF	7F01-DF21	-	-	7A-AF	7A-AF51	7C-B7	-	048.131	7F01-13	-	-	
34	PRESET/CH ▼ (DOWN)			7A-9C	7A-9C62			7F01-34	7A-6B	7A-6B95	7F01-E5	7F01-E51B	-	-	7A-11	7A-11EF	7C-B3	-	048.089	7F01-14	-	-	
35	DISPLAY			7A-C2	7A-C23C			7F01-35	7A-72	7A-728C	7F01-E0	7F01-E01E	79-0A	7F-9E	7A-B0	7A-B04E	7C-A6	-	048.015	7F01-15	-	-	
36	VOLUME -	O	O	7A-1B	7A-DB	7A-1BE5	7A-DB25	-	-	-	-	-	-	-	-	-	-	-	-	-	-	-	
37	REC			(device)	(device)	(device)	(device)	7F01-36	-	-	7F01-E6	7F01-E618	7A-4F	-	-	-	7C-8B	(DVR REC)	048.055	7F01-16	-	(DVR REC)	
38	■ (STOP)			(device)	(device)	(device)	(device)	7F01-3D	-	-	7F01-E9	7F01-E917	7A-09	7F-84	-	-	7C-85	(DVR STOP)	048.049	7F01-1D	-	(DVR STOP)	
39	■ (PAUSE)			(device)	(device)	(device)	(device)	7F01-3A	-	-	7F01-E7	7F01-E719	7A-09	7F-83	-	-	7C-83	(DVR PAUSE)	048.048	7F01-1A	-	(DVR PAUSE)	
40	▶ (PLAY)			(device)	(device)	(device)	(device)	7F01-3E	-	-	7F01-E8	7F01-E816	7A-08	7F-82	-	-	7C-82	(DVR PLAY)	048.044	7F01-1E	-	(DVR PLAY)	
41	◀ (REW)_INFO			(device)	(device)	(device)	(device)	7F01-37	7A-3D	7A-3DC3	7F01-EA	7F01-EA14	7A-0D	7F-88	7A-A4	7A-A45A	7C-86	(DVR REW)	048.041	7F01-17	-	(DVR REW)	
42	▶ (FF)			(device)	(device)	(device)	(device)	7F01-38	7A-3E	7A-3EC0	7F01-EB	7F01-EB15	7A-0C	7F-89	7A-A5	7A-A55B	7C-87	(DVR FF)	048.040	7F01-18	-	(DVR FF)	
43	◀ (SKIP -)			(device)	(device)	(device)	(device)	7F01-3B	7A-3F	7A-3FC1	7F01-EC	7F01-EC12	7A-0B	7F-86	7A-A6	7A-A658	7C-89	(DVR SKIP -)	048.033	7F01-1B	-	(DVR SKIP -)	
44	▶ (SKIP +)			(device)	(device)	(device)	(device)	7F01-3C	7A-EF	7A-EF11	7F01-ED	7F01-ED13	7A-0A	7F-87	7A-A7	7A-A759	7C-BA	(DVR SKIP +)	048.032	7F01-1C	-	(DVR SKIP +)	
45	1 ◀ PRG			7A-59	7A-59A7			7F01-21	7A-61	7A-619F	7F01-D1	7F01-D12F	79-11	7F-91	7A-E5	7A-E51B	7C-94	-	048.001	7F01-01	-	-	
46	2 PRG ▶			7A-58	7A-58A6			7F01-22	7A-62	7A-629C	7F01-D2	7F01-D22C	79-12	7F-92	7A-E6	7A-E618	7C-95	-	048.002	7F01-02	-	-	
47	3 ENHANCER			7A-94	7A-946A			7F01-23	7A-63	7A-639D	7F01-D3	7F01-D32D	79-13	7F-93	7A-E7	7A-E719	7C-96	-	048.003	7F01-03	-	-	
48	4 SUR_DECODE			7A-8D	7A-8D73			7F01-24	7A-64	7A-649A	7F01-D4	7F01-D42A	79-14	7F-94	7A-E8	7A-E816	7C-97	-	048.004	7F01-04	-	-	
49	5 STRAIGHT			7A-56	7A-56A8			7F01-25	7A-65	7A-659B	7F01-D5	7F01-D52B	79-15	7F-95	7A-E9	7A-E917	7C-98	-	048.005	7F01-05	-	-	
50	6 DIRECT			7A-DD	7A-DD23			7F01-26	7A-66	7A-6698	7F01-D6	7F01-D628	79-16	7F-96	7A-EA	7A-EA14	7C-99	-	048.006	7F01-06	-	-	
51	7 NIGHT			7A-95	7A-956B			7F01-27	7A-67	7A-6799	7F01-D7	7F01-D729	79-17	7F-97	7A-EB	7A-EB15	7C-9A	-	048.007	7F01-07	-	-	
52	8 PARAMETER			7A-C4	7A-C43A			7F01-28	7A-68	7A-6896	7F01-D8	7F01-D826	79-18	7F-98	7A-EC	7A-EC12	7C-9B	-	048.008	7F01-08	-	-	
53	9 MULTI CH IN			7A-87	7A-8779			7F01-29	7A-69	7A-6997	7F01-D9	7F01-D927	79-19	7F-99	7A-B1	7A-B14F	7C-9C	-	048.009	7F01-09	-	-	
54	0 AUDIO SEL			7A-C3	7A-C33D			7F01-2A	7A-60	7A-609E	7F01-DA	7F01-DA24	79-10	7F-90	7A-B2	7A-B24C	7C-93	-	048.000	7F01-0A	-	-	
55	+10			-	-			7F01-2B	-	-	7F01-DB	7F01-DB25	79-1A	7F-9A									

• FUNCTION CHART

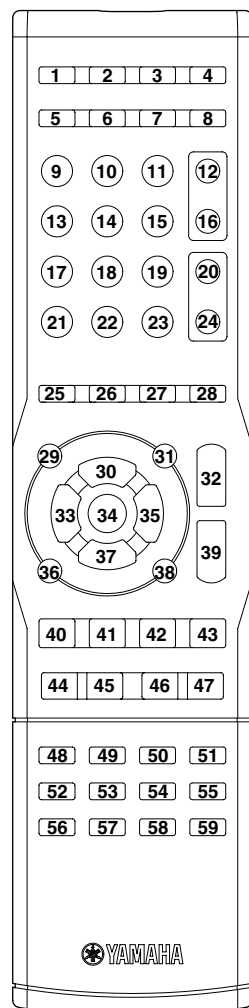

Key no.	Label	K21 [AMP]	K5 [USB] RAV282	K6 [XM] RAV280	K7 [SIRIUS] RAV280	K9 [CD]	K10 [MD/CD-R]	K11 [TUNER]	K13 [DVD]	K14 [DTV/CBL]	K15 [DVR]	K17 [V-AUX]	K18 [VCR]	K19 [PHONO]
1	POWER_TV	(TV POWER)	(TV POWER)	(TV POWER)	(TV POWER)	(TV POWER)	(TV POWER)	(TV POWER)	(TV POWER)	(TV POWER)	(TV POWER)	(TV POWER)	(TV POWER)	(TV POWER)
2	POWER_AV	(device)	POWER	POWER	POWER	POWER	POWER	POWER	POWER	(DVR POWER)	POWER	POWER	POWER	(DVR POWER)
12	TV CH +	(TV CH +)	(TV CH +)	(TV CH +)	(TV CH +)	(TV CH +)	(TV CH +)	(TV CH +)	(TV CH +)	(TV CH +)	(TV CH +)	(TV CH +)	(TV CH +)	(TV CH +)
16	TV CH -	(TV CH -)	(TV CH -)	(TV CH -)	(TV CH -)	(TV CH -)	(TV CH -)	(TV CH -)	(TV CH -)	(TV CH -)	(TV CH -)	(TV CH -)	(TV CH -)	(TV CH -)
20	TV VOL +	(TV VOL +)	(TV VOL +)	(TV VOL +)	(TV VOL +)	(TV VOL +)	(TV VOL +)	(TV VOL +)	(TV VOL +)	(TV VOL +)	(TV VOL +)	(TV VOL +)	(TV VOL +)	(TV VOL +)
22	TV INPUT	(TV INPUT)	(TV INPUT)	(TV INPUT)	(TV INPUT)	(TV INPUT)	(TV INPUT)	(TV INPUT)	(TV INPUT)	(TV INPUT)	(TV INPUT)	(TV INPUT)	(TV INPUT)	(TV INPUT)
23	TV MUTE	(TV MUTE)	(TV MUTE)	(TV MUTE)	(TV MUTE)	(TV MUTE)	(TV MUTE)	(TV MUTE)	(TV MUTE)	(TV MUTE)	(TV MUTE)	(TV MUTE)	(TV MUTE)	(TV MUTE)
24	TV VOL -	(TV VOL -)	(TV VOL -)	(TV VOL -)	(TV VOL -)	(TV VOL -)	(TV VOL -)	(TV VOL -)	(TV VOL -)	(TV VOL -)	(TV VOL -)	(TV VOL -)	(TV VOL -)	(TV VOL -)
25	SCENE 1	SCENE 1												
26	SCENE 2	SCENE 2												
27	SCENE 3	SCENE 3												
28	SCENE 4	SCENE 4												
29	BAND LEVEL / TITLE	LEVEL	TITLE	BAND	TITLE	-	-	BAND	TITLE	TITLE	TITLE	BAND	TITLE	TITLE
30	PRESET/CH ▲ (UP)	MENU UP	UP	PRESET (+)	UP	-	-	PRESET (+)	MENU UP	MENU UP	MENU UP	PRESET (+)	-	MENU UP
31	SRCH MODE / MENU	MENU	MENU	SRCH MODE	SRCH MODE	-	-	SRCH MODE	MENU	MENU	MENU	SRCH MODE	-	MENU
32	VOLUME +	VOLUME (+)												
33	A-E/CAT. / A/B/C/D/E ◀ (LEFT)	MENU LEFT	LEFT	A-E/CAT. (-)	LEFT	-	-	A-E/CAT. (-)	MENU LEFT	MENU LEFT	MENU LEFT	A-E/CAT. (-)	-	MENU LEFT
34	ENTER	MENU SELECT	ENTER	ENTER	ENTER	-	-	ENTER	MENU ENTER	MENU ENTER	MENU ENTER	ENTER	-	MENU ENTER
35	A-E/CAT. / A/B/C/D/E ▶ (RIGHT)	MENU RIGHT	RIGHT	A-E/CAT. (+)	RIGHT	-	-	A-E/CAT. (+)	MENU RIGHT	MENU RIGHT	MENU RIGHT	A-E/CAT. (+)	-	MENU RIGHT
36	RETURN / MEMORY	RETURN	RETURN	MEMORY	MEMORY	-	-	MEMORY	RETURN	RETURN	RETURN	MEMORY	RETURN	RETURN
37	PRESET/CH ▼ (DOWN)	MENU DOWN	DOWN	PRESET (-)	DOWN	-	-	PRESET (-)	MENU DOWN	MENU DOWN	MENU DOWN	PRESET (-)	-	MENU DOWN
38	DISPLAY	SUB MENU	DISPLAY	DISPLAY	DISPLAY	DISPLAY	DISPLAY	DISPLAY	DISPLAY	DISPLAY	DISPLAY	DISPLAY	-	DISPLAY
39	VOLUME -	VOLUME (-)												
40	REC	(device)	-	-	REC	DISC SKIP	REC	-	DISC SKIP	(DVR REC)	REC	-	REC	(DVR REC)
41	■ (STOP)	(device)	STOP	-	STOP	STOP	STOP	-	STOP	(DVR STOP)	STOP	-	STOP	(DVR STOP)
42	■ (PAUSE)	(device)	PAUSE	-	PAUSE	PAUSE	PAUSE	-	PAUSE	(DVR PAUSE)	PAUSE	-	PAUSE	(DVR PAUSE)
43	▶ (PLAY)	(device)	PLAY	-	PLAY	PLAY	PLAY	-	PLAY	(DVR PLAY)	PLAY	-	PLAY	(DVR PLAY)
44	◀◀ (REW) INFO	(device)	-	INFO	REW	REW	REW	INFO	REW	(DVR REW)	REW	INFO	REW	(DVR REW)
45	▶▶ (FF)	(device)	-	EON	FF	FF	FF	EON	FF	(DVR FF)	FF	EON	FF	(DVR FF)
46	◀◀ (SKIP -) PTY SEEK-MODE	(device)	SKIP (-)	PTY MODE	SKIP (-)	SKIP (-)	SKIP (-)	PTY MODE	SKIP (-)	(DVR SKIP -)	SKIP (-)	PTY MODE	-	(DVR SKIP -)
47	▶▶ (SKIP +) PTY SEEK-START	(device)	SKIP (+)	PTY START	SKIP (+)	SKIP (+)	SKIP (+)	PTY START	SKIP (+)	(DVR SKIP +)	SKIP (+)	PTY START	-	(DVR SKIP +)
48	1 ◀ PRG	PROG (-)	P1	P1	1	1	1	P1	1	1	1	P1	1	1
49	2 ▶ PRG	PROG (+)	P2	P2	2	2	2	P2	2	2	2	P2	2	2
50	3 ENHANCER	ENHANCER	P3	P3	3	3	3	P3	3	3	3	P3	3	3
51	4 SUR. DECODE	SUR.DECODE	P4	P4	4	4	4	P4	4	4	4	P4	4	4
52	5 STRAIGHT	STRAIGHT	P5	P5	5	5	5	P5	5	5	5	P5	5	5
53	6 DIRECT	(PURE) DIRECT	P6	P6	6	6	6	P6	6	6	6	P6	6	6
54	7 NIGHT	NIGHT	P7	P7	7	7	7	P7	7	7	7	P7	7	7
55	8 PARAMETER	PARAMENTER	P8	P8	8	8	8	P8	8	8	8	P8	8	8
56	9 MULTI CH IN	MULTI CH IN	P9	P9	9	9	9	P9	9	9	9	P9	9	9
57	0 AUDIO SEL	AUDIO SEL	P10	P0	10	0/10	0/10	P0	0	0/10	0	P0	0/10	0/10
58	+10	-	-	-	11	+10	+10	-	+10	/...11	+10	-	>10	/...11
59	ENT_SLEEP	SLEEP	P.ENTER	P.ENTER	12	INDEX	INDEX	P.ENTER	TITLE/INDEX	ENTER/12	TITLE/INDEX	P.ENTER	ENTER	ENTER/12



Advanced setup

Advanced setup

This unit has additional menus that are displayed in the front panel display. The advanced setup menu offers additional operations to adjust and customize the way this unit operates. Change the initial settings (indicated in bold under each parameter) to reflect the needs of your listening environment.

**Notes**

- Only **MAIN ZONE ON/OFF PROGRAM** </> and **STRAIGHT** are effective while you are using the advanced setup menu.
- No other operations can be made while you are using the advanced setup menu.
- The advanced setup menu is only available in the front panel display.

**1 Press SYSTEM OFF to set this unit to the standby mode.**

**2 Press and hold TONE CONTROL and then press MAIN ZONE ON/OFF to turn on this unit.**  
This unit turns on, and the advanced setup menu appears in the front panel display.

**3 Press PROGRAM </>/> to select the parameter you want to adjust.**  
The name of the selected parameter appears in the front panel display.

**4 Press STRAIGHT repeatedly to change the selected parameter setting.**

**5 Press MAIN ZONE ON/OFF to confirm your selection and set this unit to the standby mode.**

\*The settings you made are reflected next time you turn on this unit.

**■ Speaker impedance SP IMP. (U.S.A. and Canada models only)**  
Use this feature to set the speaker impedance of this unit so that it matches that of your speakers.

- Choices: **8Ω MIN**, 6Ω MIN
- Select "8Ω MIN" to set the speaker impedance to 8 Ω.
- Select "6Ω MIN" to set the speaker impedance to 6 Ω.

SP IMP.	Speaker	Impedance level
8Ω MIN	Front (A or B) Center Surround	The impedance of each speaker must be 8 Ω or higher.
6Ω MIN	Front (A or B) Center Surround	The impedance of each speaker must be 6 Ω or higher.

**■ SIRIUS Satellite Radio Parental Lock code number reset SSR PIN**  
Use this feature to set the code number for the SIRIUS Satellite Radio Parental Lock feature to the initial factory setting.

- Choices: **RESET**, **CANCEL**
- Select "RESET" to set the code number to the initial factory setting.
- Select "CANCEL" to set the code number to the initial factory setting.

**Note**

Even if you set "SSR PIN" to "RESET", this unit does not unlock the locked channels. The initial factory setting of the Parental Lock code number is "0000".

**■ Bi-amplifier setting BI-AMP**  
Use this feature to activate or deactivate the bi-amplifier function.

- Choices: **ON**, **OFF**
- Select "ON" if you want to activate the bi-amplifier function. "SUR.B L/R SP" is set to "NONE" automatically, and this unit outputs the front channel audio signals at the SURROUND BACK/BI-AMP speaker terminals.
- Select "OFF" if you want to deactivate the bi-amplifier function.

**■ SCENE IR code setting SCENE IR**  
Use this feature to output the remote control signals at the REMOTE OUT jack automatically when this unit is in the SCENE mode.

- Choices: **ON**, **OFF**
- Select "ON" when the component connected to the REMOTE OUT jack is the Yamaha component and has the capability of the SCENE control signals. This unit automatically sends the remote control signals to the component.
- Select "OFF" when the component connected to the REMOTE OUT jack is not the Yamaha component and does not have the capability of the SCENE control signals.

**Note**

If noises are output when you operate the SCENE function, set "SCENE IR" to "OFF".

**■ Tuner frequency step TU (Asia and General models only)**  
Use this feature to set the tuner frequency step according to the frequency spacing in your area.

- Choices: **AM10/FM100**, **AM9/FM50**
- Select "AM10/FM100" for North, Central and South America.
- Select "AM9/FM50" for all other areas.

**■ Initializing INIT**  
Use this feature to reset all the parameters of this unit to the initial factory settings.

- Choices: **CANCEL**, **RESET**
- Select "CANCEL" not to reset any parameters of this unit.
- Select "RESET" to reset the parameters of this unit.

**Notes**

- This setting completely resets all the parameters of this unit including the "SET MENU" parameters. However, the advanced setup menu parameters will not be initialized.
- The initial factory settings are activated next time you turn on this unit.

# **RX-V563/HTR-6150/ DSP-AX563**

---

