

Service
Service
Service



Service Manual

TABLE OF CONTENTS

Page

- . Location of PCB Boards,Version Variation and Repair Scenario Matrix.....1-2
- . Technical Specifications.....1-3
- . Safety Instruction, Warning & Notes.....1-4
- . DFU Instruction.....2-1
- . Mechanical and Dismantling Instructions.....3-1
- . Software Upgrades4-1
- . Trouble Shooting Chart.....5-1
- . Wiring Diagram.....6-1
- . Electrical Diagrams and Print-layouts.....7-1
- . Voltages and Waveforms for Connection Pins.....8-1
- . Pin Description & Block Diagrams of ICs.....9-1
- . Set Mechanical Exploded view & Part list.....10-1
- . Revision List.....11-1

©Copyright 2013 Philips Consumer Electronics B.V. Eindhoven, The Netherlands
All rights reserved. No part of this publication may be reproduced, stored in a retrieval system or transmitted, in any form or by any means, electronic, mechanical, photocopying, or otherwise without the prior permission of Philips.



GB 3141 785 39171



PCB Board Locations:

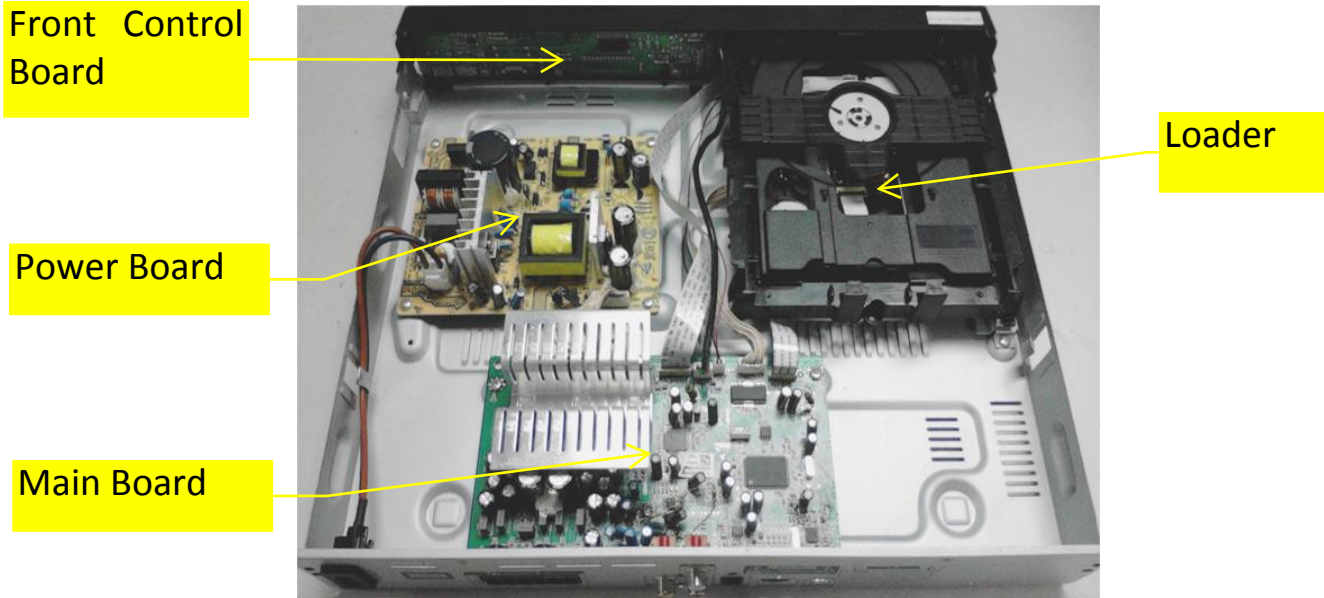

VERSION VARIATIONS

Type / Versions Board in used Service Policy		HTD3570		
		/12	/98	/51
MAIN BOARD		M+C	M+C	M+C
FRONT CONTROL BOARD		M+C	M+C	M+C
POWER BOARD		M+C	M+C	M+C
LOADER		M	M	M
* Tips:	C -- Component Lever Repair M -- Module Lever Repair X -- Used			

Product specifications



Note

- Specifications and design are subject to change without notice.

Region codes

The type plate on the back or bottom of the home theater shows which regions it supports.

Country	DVD
Europe, United Kingdom	
Asia Pacific, Taiwan, Korea	
Latin America	
Australia, New Zealand	
Russia, India	
China	

Media formats

- DVD-Video, DVD+R/RW, DVD-R/RW, DVD+R-R DL, CD-R/CD-RW, Audio CD, Video CD/SVCD, Picture files, MP3 media, WMA media, DivX media, USB storage device

File formats

- Audio: .mp3, .wma

- Video: .avi, .divx, .mpg, .mpeg,
- Picture: .jpg, .jpeg

Amplifier

- Total output power: 300W RMS (30% THD)
- Frequency response: 20 Hz-20 kHz / ± 3 dB
- Signal-to-noise ratio: > 65 dB (CCIR) / (A-weighted)
- Input sensitivity:
 - AUX: 2 V
 - AUDIO IN: 1 V

Video

- Signal system: PAL / NTSC/Multi
- HDMI output: 480i/576i, 480p/576p, 720p, 1080i, 1080p

Audio

- S/PDIF Digital audio input:
 - Optical: TOSLINK
- Sampling frequency:
 - MP3: 32 kHz, 44.1 kHz, 48 kHz
 - WMA: 44.1 kHz, 48 kHz
- Constant bit rate:
 - MP3: 32 kbps - 320 kbps
 - WMA: 64 kbps - 192 kbps

Radio

- Tuning range:
 - Europe/Russia/China: FM 87.5-108 MHz (50 kHz)
 - Asia Pacific/Latin America: FM 87.5-108 MHz (50/100 kHz)
- Signal-to-noise ratio: FM 50 dB
- Frequency response: FM 200 Hz-12.5 kHz / ± 6 dB

USB

- Compatibility: Hi-Speed USB (2.0)

- Class support: USB Mass Storage Class (MSC)
- File system: FAT16, FAT32, NTFS
- USB port: 5V $\overline{=}$, 500mA

Main unit

- Power supply:
 - Europe/China/Russia/India: 220-240V~, 50 Hz
 - Latin America/Asia Pacific: 110-240V~, 50-60 Hz
- Power consumption: 50 W
- Standby power consumption: \leq 0.5 W
- Dimensions (WxHxD): 360 x 58 x 325 mm
- Weight: 2.3 kg

Subwoofer

- Output power: 50 W RMS (30% THD)
- Impedance: 8 ohm
- Speaker drivers: 133 mm (5.25") woofer
- Dimensions (WxHxD): 160 x 265 x 265 mm
- Weight: 2.50 kg
- Cable length:
 - **HTD3510**: 2.3 m
 - **HTD3540/HTD3570**: 3.3 m

Speakers

Center speaker:

- Output power: 50 W RMS (30% THD)
- Speaker impedance: 4 ohm
- Speaker drivers: 1 x 63.5 mm (2.5") full range
- Dimensions (WxHxD):
 - **HTD3510**: 85 x 88 x 83 mm
 - **HTD3540/HTD3570**: 185 x 90 x 82 mm
- Weight:
 - **HTD3510**: 0.26 kg
 - **HTD3540/HTD3570**: 0.35 kg
- Cable length:
 - **HTD3510**: 1.2 m
 - **HTD3540/HTD3570**: 2.25 m

Front/Rear speaker:

- Output power: 4 x 50 W RMS (30% THD)
- Speaker impedance: 4 ohm
- Speaker drivers: 1 x 63.5 mm (2.5") full range
- Dimensions (WxHxD):
 - **HTD3510**: 85 x 88 x 83 mm (front/rear)
 - **HTD3540**: 85 x 159 x 80 mm (front); 240 x 1006 x 240 mm (rear)
 - **HTD3570**: 240 x 1006 x 240 mm (front/rear)
- Weight (front):
 - **HTD3510**: 0.25 kg/each
 - **HTD3540**: 0.35 kg/each
 - **HTD3570**: 2.56 kg/each
- Weight (rear):
 - **HTD3510**: 0.25 kg/each
 - **HTD3540/HTD3570**: 2.56 kg/each
- Cable length (front):
 - **HTD3510**: 2.2 m
 - **HTD3540/HTD3570**: 3.25 m
- Cable length (rear): 7.2 m

Remote control batteries

- 1 x AAA-R03-1.5 V

Laser

- Type: Semiconductor laser GaAlAs (CD)
- Wave length: 650-662 nm (DVD), 785-795 nm (CD)
- Output power: 6 mW (DVD), 7 mW (VCD/CD)
- Beam divergence: 60 degrees.

Safety instruction, Warning & Notes

Safety instruction

1. General safety

Safety regulations require that during a repair:

- . Connect the unit to the mains via an isolation transformer.
- . Replace safety components indicated by the symbol ▲, only by components identical to the original ones. Any other component substitution (other than original type) may increase risk of fire or electrical shock hazard.

Safety regulations require that after a repair, you must return the unit in its original condition. Pay, in particular, attention to the following points:

- . Route the wires/cables correctly, and fix them with the mounted cable clamps.
- . Check the insulation of the mains lead for external damage.
- . Check the electrical DC resistance between the mains plug and the secondary side:
 - 1) Unplug the mains cord, and connect a wire between the two pins of the mains plug.
 - 2) Set the mains switch the "on" position (keep the mains cord unplug).
 - 3) Measure the resistance value between the mains plug and the front panel, controls, and chassis bottom.
 - 4) Repair or correct unit when the resistance measurement is less than 1M Ω .
 - 5) Verify this, before you return the unit to the customer/user (ref. UL-standard no. 1492).
 - 6) Switch the unit "off", and remove the wire between the two pins of the mains plug.

2.Laser safety

This unit employs a laser. Only qualified service personnel may remove the cover, or attempt to service this device (due to possible eye injury).

Laser device unit

Type	: Semiconductor laser GaAlAs
Wavelength	: 650nm (DVD)
	: 780nm (VCD/CD)
Output power	: 7mW (DVD)
	: 10mW (DVD /CD)

Beam divergence: 60 degree

Note: Use of controls or adjustments or performance of procedure other than those specified herein, may result in hazardous radiation exposure. Avoid direct exposure to beam.

Warning

1. General

. All ICs and many other semiconductors are susceptible to electrostatic discharges (ESD). Careless handling during repair can reduce life drastically. Make sure that, during repair, you are at the same potential as the mass of the set by a wristband with resistance. Keep components and tools at this same potential. Available ESD protection equipment:

- 1) Complete kit ESD3 (small tablemat, wristband, connection box, extension cable and earth cable) 4822 310 10671.
- 2) Wristband tester 4822 344 13999.

. Be careful during measurements in the live voltage section. The primary side of the power supply, including the heat sink, carries live mains voltage when you connect the player to the mains (even when the player is "off!"). It is possible to touch copper tracks and/or components in this unshielded primary area, when you service the player. Service personnel must take precautions to prevent touching this area or components in this area. A "lighting stroke" and a stripe-marked printing on the printed wiring board, indicate the primary side of the power supply.

. Never replace modules, or components, while the unit is "on".

2. Laser

- . The use of optical instruments with this product, will increase eye hazard.
- . Only qualified service personnel may remove the cover or attempt to service this device, due to possible eye injury.
- . Repair handling should take place as much as possible with a disc loaded inside the player.
- . Text below is placed inside the unit, on the laser cover shield:

CAUTION: VISIBLE AND INVISIBLE LASER RADIATION WHEN OPEN, AVOID EXPOSURE TO BEAM.

Notes: Manufactured under licence from Dolby Laboratories. The double-D symbol is trademarks of Dolby Laboratories, Inc. All rights reserved.

Service Hints

CAUTION

CHARGED CAPACITORS ON THE SERVO BOARD MAY DAMAGE THE DRIVE ELECTRONICS WHEN CONNECTING A NEW DRIVE. THAT'S WHY, BESIDES THE SAFETY MEASURES LIKE

- SWITCH OFF POWER SUPPLY
- ESD PROTECTION

ADDITIONAL ACTIONS MUST BE TAKEN BY THE REPAIR TECHNICIAN.

The following steps have to be done when replacing the defective loader :

1. Dismantling of the loader to access the ESD protection point if necessary.
2. **Solder the ESD protection point***.
3. Disconnect flexfoil cable from the defective loader.
4. Put a paper clip on the flexfoil to short-circuit the contacts (fig.1)
5. Replace the defective loader with a new loader.
6. Remove paperclip from the flexfoil and connect it to the new loader.
7. Remove solder joint on the ESD protection point.

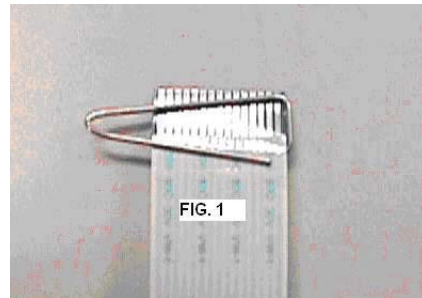

ATTENTION: The laser diode of this loader is protected against ESD by a solder joint which shortcircuits the laserdiode to ground. For proper functionality of the loader this solder joint must be remove **after** connection loader to the set.

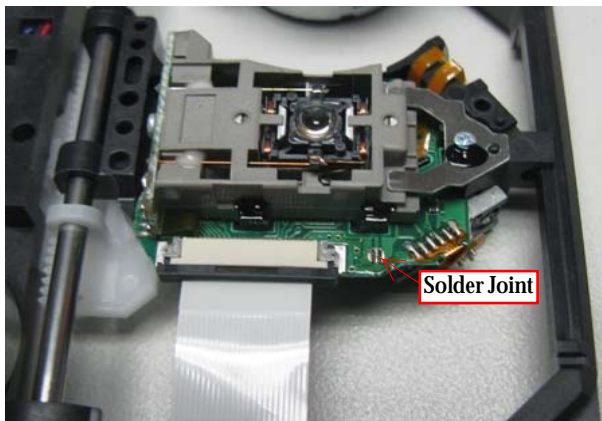

(ESD protection point is accessible from top of loader)

****Only applicable for defective loader needed to be sent back to supplier for failure analysis and to support backcharging evidence.***

This is also applicable for all partnership workshops.

Notes

Lead-Free requirement for service

IDENTIFICATION:

Regardless of special logo (not always indicated) 

One must treat all sets from 1.1.2005 onwards, according next rules.

Important note: In fact also products a little older can also be treated in this way as long as you avoid mixing solder-alloys (leaded/ lead-free). So best to always use SAC305 and the higher temperatures belong to this.

Due to lead-free technology some rules have to be respected by the workshop during a repair:

- Use only lead-free solder alloy Philips SAC305 with order code 0622 149 00106. If lead-free solder-paste is required, please contact the manufacturer of your solder-equipment. In general use of solder-paste within workshops should be avoided because paste is not easy to store and to handle.
- Use only adequate solder tools applicable for lead-free solder alloy. The solder tool must be able
 - To reach at least a solder-temperature of 400°C,
 - To stabilize the adjusted temperature at the solder-tip
 - To exchange solder-tips for different applications.
- Adjust your solder tool so that a temperature around 360°C – 380°C is reached and stabilized at the solder joint. Heating-time of the solder-joint should not exceed ~ 4 sec. Avoid temperatures above 400°C otherwise wear-out of tips will rise drastically and flux-fluid will be destroyed. To avoid wear-out of tips switch off un-used equipment, or reduce heat.
- Mix of lead-free solder alloy / parts with leaded solder alloy / parts is possible but PHILIPS recommends strongly to avoid mixed solder alloy types (leaded and lead-free). If one cannot avoid, clean carefully the solder-joint from old solder alloy and re-solder with new solder alloy (SAC305).

- Use only original spare-parts listed in the Service-Manuals. Not listed standard-material (commodities) has to be purchased at external companies.
- Special information for BGA-ICs:
 - always use the 12nc-recognizable soldering temperature profile of the specific BGA (for de-soldering always use highest lead-free temperature profile, in case of doubt)
 - lead free BGA-ICs will be delivered in so-called 'dry-packaging' (sealed pack including a silica gel pack) to protect the IC against moisture. After opening, dependent of MSL-level seen on indicator-label in the bag, the BGA-IC possibly still has to be baked dry. This will be communicated via AYS-website.
- Do not re-use BGAs at all.
- For sets produced before 1.1.2005, containing leaded soldering-tin and components, all needed spare-parts will be available till the end of the service-period. For repair of such sets nothing changes.
- On our website:

www.atyourservice.ce.Philips.com

You find more information to:

BGA-de-/soldering (+ baking instructions)
Heating-profiles of BGAs and other ICs used in Philips-sets

You will find this and more technical information within the "magazine", chapter "workshop news".
For additional questions please contact your local repair-helpdesk.



EN Before using your product, read all accompanying safety information

DA Læs alle medfølgende sikkerhedsoplysninger, inden du tager produktet i brug

DE Lesen Sie vor Verwendung dieses Produkts alle begleitenden Sicherheitsinformationen

EL Πριν χρησιμοποιήσετε το προϊόν, διαβάστε όλες τις παρεχόμενες πληροφορίες ασφάλειας

ES Antes de usar el producto, lea toda la información de seguridad adjunta

FI Lue kaikki turvallisuustiedot ennen tuotteen käyttöä

FR Avant d'utiliser votre produit, lisez l'intégralité des consignes de sécurité jointes

IT Prima di utilizzare il prodotto, leggere tutte le relative informazioni sulla sicurezza

NL Lees voordat u het product gaat gebruiken eerst alle bijbehorende veiligheidsinformatie

NO Les all vedlagt sikkerhetsinformasjon før du bruker produktet

PT Antes de utilizar o produto, leia todas as informações de segurança que o acompanham

SV Innan du använder produkten ska du läsa all tillhörande säkerhetsinformation

TR Ürününüzü kullanmadan önce ilgili tüm güvenlik bilgilerini okuyun

CS Před použitím produktu si přečtěte doprovodné bezpečnostní informace

HU A termék használatá elótt alaposan olvassa el a mellékelt biztonsági tudnivalókat

PL Przed rozpoczęciem korzystania z produktu należy zapoznać się z informacjami dotyczącymi bezpieczeństwa

RO Înainte de a utiliza acest produs, citiți toate informațiile de siguranță care îl însoțesc

SK Pred použitím produktu si prečítajte všetky sprievodné bezpečnostné informácie

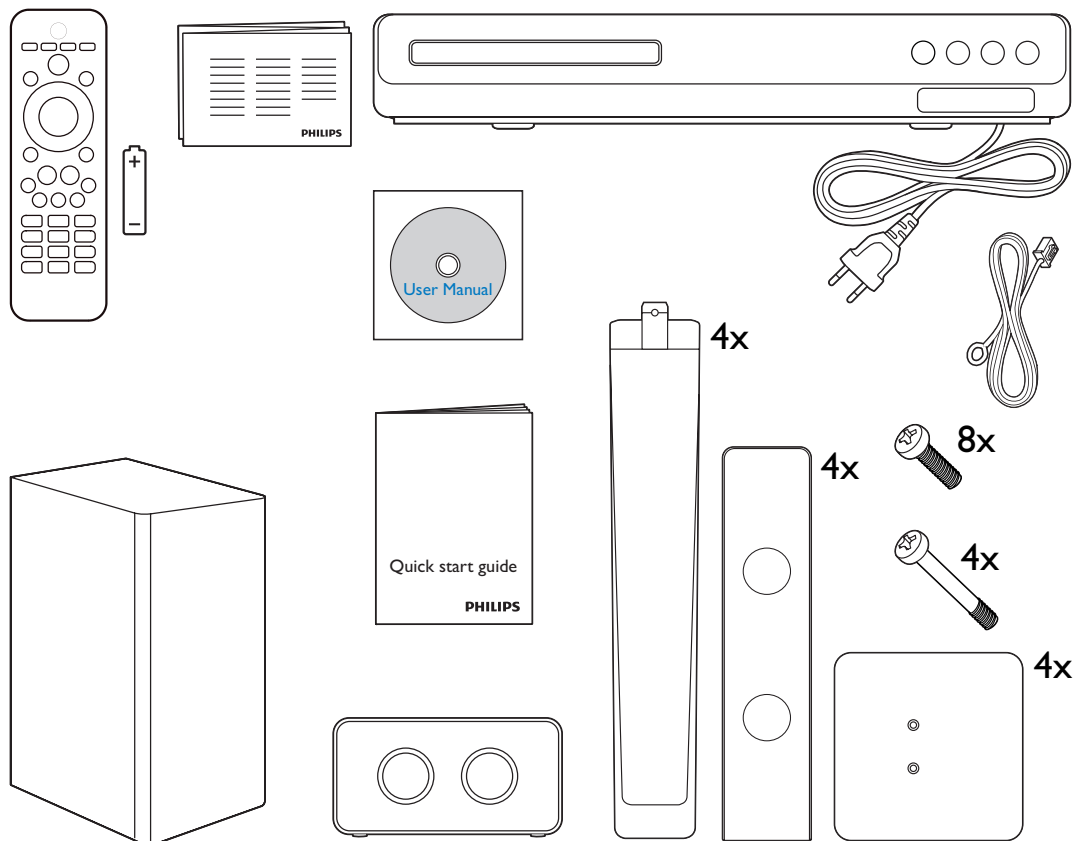

1

EN Stand mount the speakers

CS Nainstalujte reproduktory

DA Monter højttalerne på fod

DE Montage der Lautsprecher auf den Standfüßen

EL Στήστε τα ηχεία πάνω στις βάσεις

ES Monta los altavoces en la pared

FI Kaiuttimien kiinnitys jalustaan

FR Monter le pied des enceintes

HU A hangsugárzók állványra szerelése

IT Montaggio degli altoparlanti su supporto

NL Monteer de luidsprekers op de standaarden

NO Montere høyttalerne på stativ

PL Montaż głośników na podstawie

PT Colocar os altifalantes no suporte

RO Montați pe suport boxe

SK Montáž reproduktorov na stojan

SV Montera högtalarna på stativ

TR Hoparlörleri kaideye monte edin

1

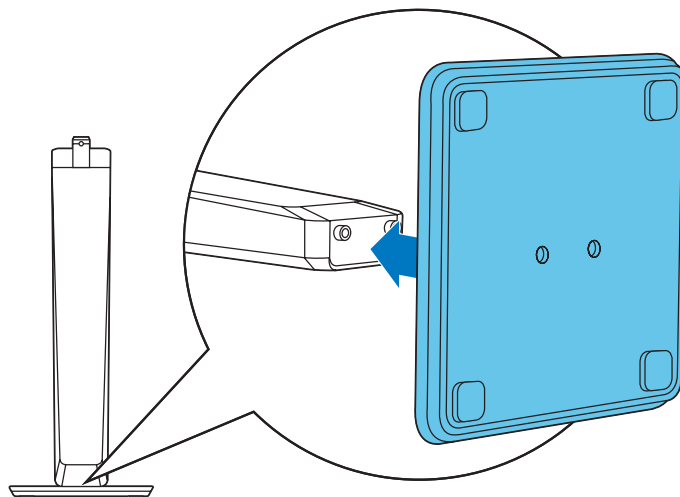

2

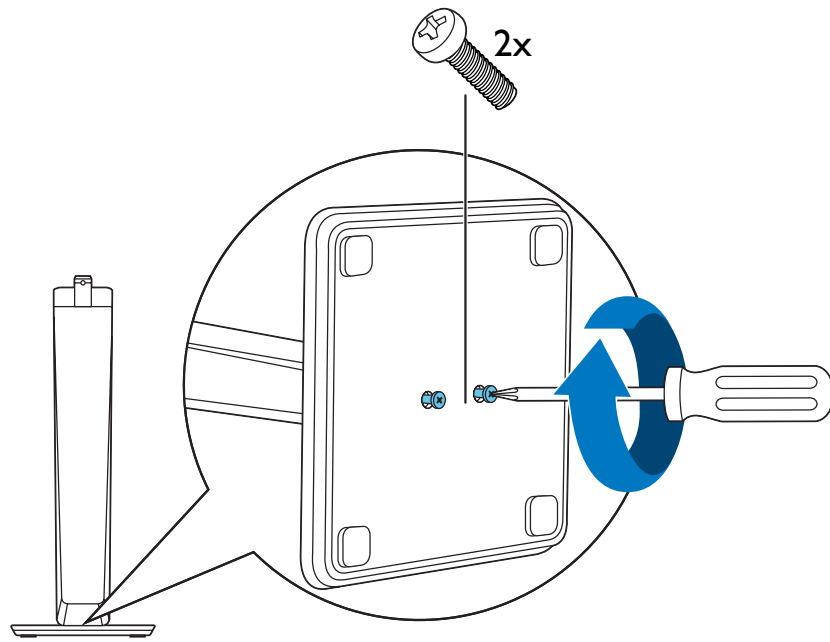

3

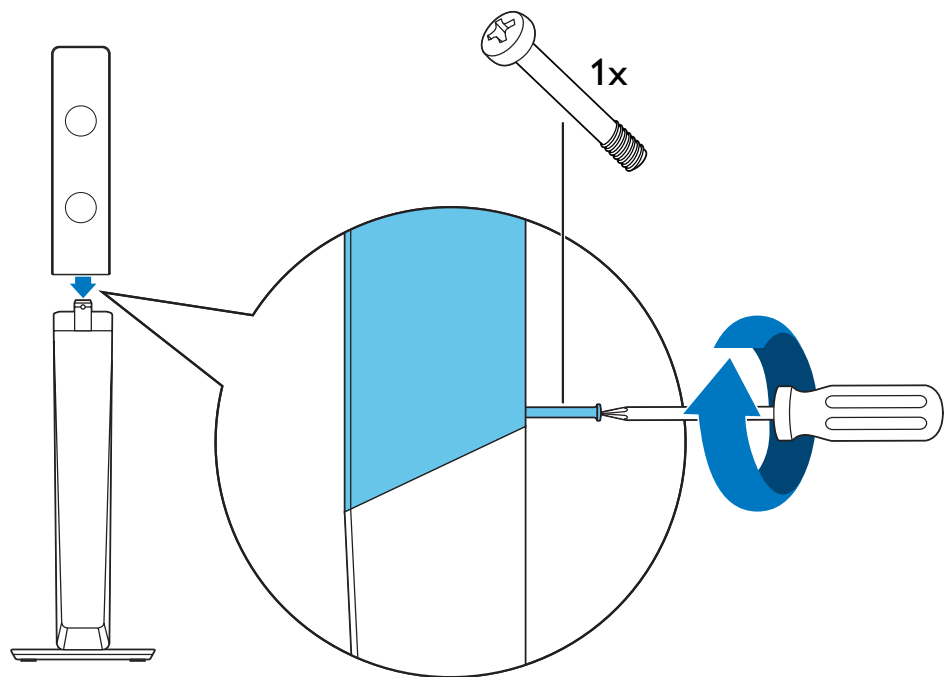

2

EN Connect the home theater

DA Tilslut hjemmebiografen

DE Anschließen des Home Entertainment-Systems

EL Συνδέστε το home cinema

ES Conecta el sistema de cine en casa

FI Kotiteatterin liittäät

FR Connecter les enceintes au Home Cinéma

IT Collegamento del sistema Home Theater

NL Sluit de home cinema aan

NO Koble til hjemmekinoanlegget

PT Efectuar as ligações ao sistema de cinema em casa

SV Anslut hemmabiosystemet

TR Ev sinemasını bağlayın

CS Připojte domácí kino

HU A házimozi csatlakoztatása

PL Podłączanie zestawu kina domowego

RO Conectați sistemul home theater

SK Pripojenie k domácemu kinu

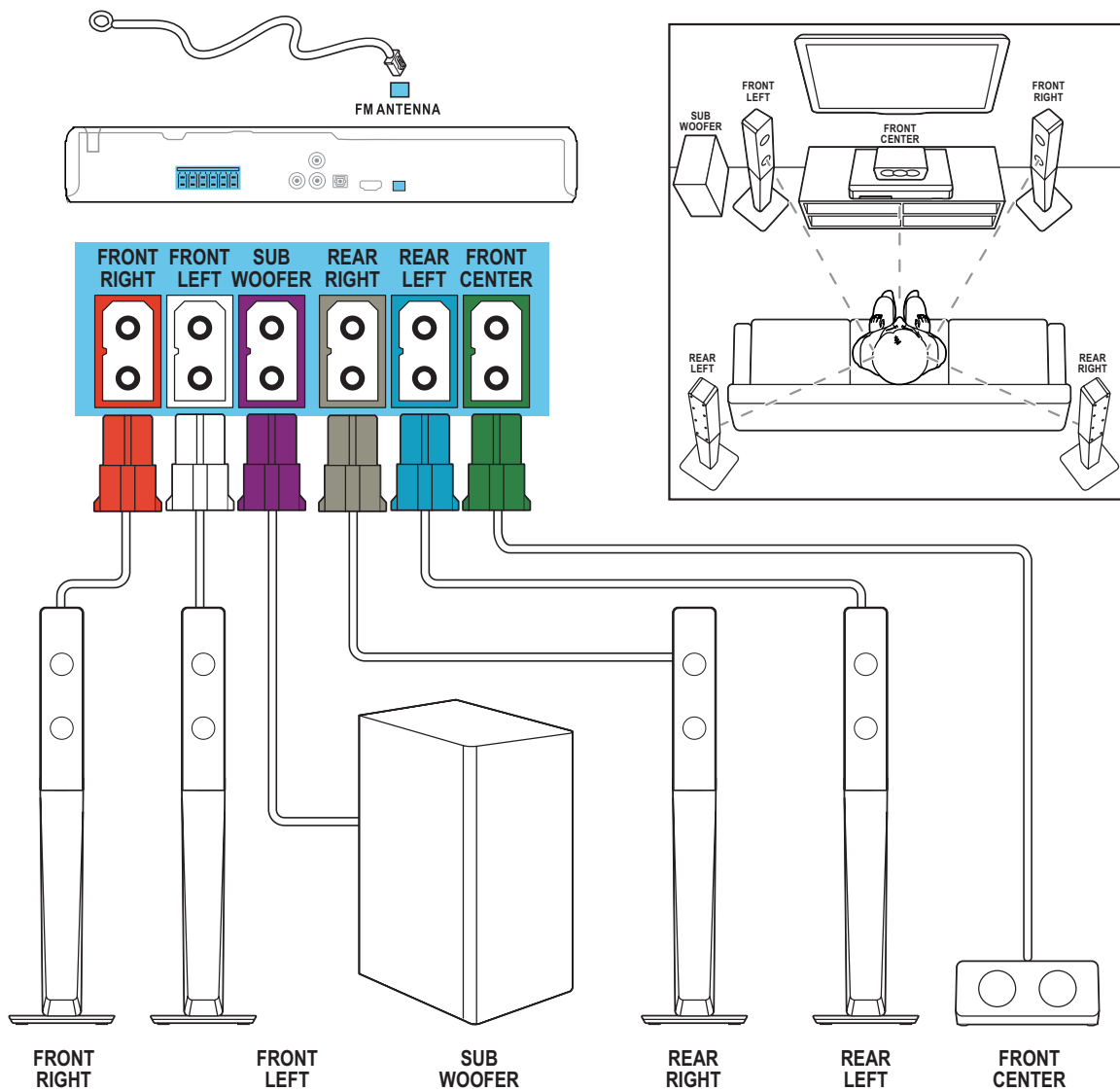

3

EN Connect to TV in one of these ways

DA Tilslut til TV på en af følgende måder

DE Herstellen einer Verbindung mit dem Fernseher über einer dieser Möglichkeiten

EL Συνδεθείτε στην τηλεόραση με έναν από τους παρακάτω τρόπους

ES Conexión al televisor de una de estas maneras

FI Liitä televisioon jommallakummalla tavalla

FR Connectez-vous au téléviseur via l'une de ces méthodes

IT Esegui il collegamento al TV in uno dei modi indicati di seguito

NL Maak op een van de volgende manieren verbinding met de TV

NO Koble til TV'en på en av følgende måter

PT Ligar ao televisor de uma destas formas

SV Anslut till TV:n på något av följande sätt

TR Aşağıdaki yöntemlerden biriyle TV'ye bağlanın

CS Připojení k televizoru proveďte jedním z následujících způsobů

HU Csatlakoztassa a tv-készülékhez az alábbi módok egyike szerint

PL Podłącz do telewizora przy użyciu jednej z tych metod

RO Conectați-vă la televizor într-unul din aceste moduri

SK Pripojte zariadenie k televízoru jedným z týchto spôsobov

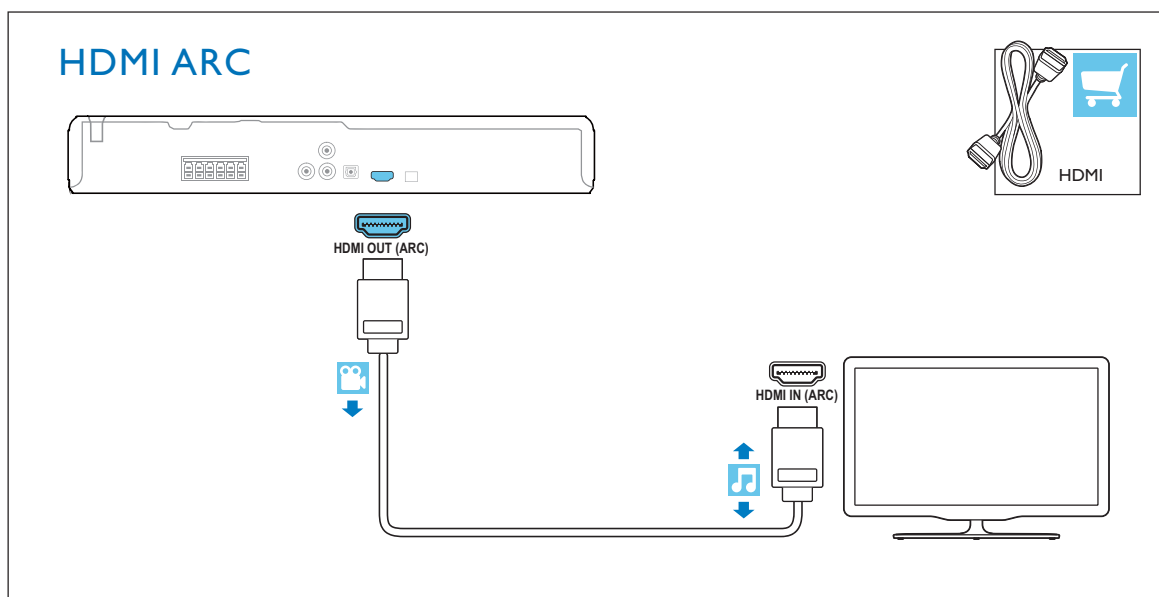

HDMI + OPTICAL

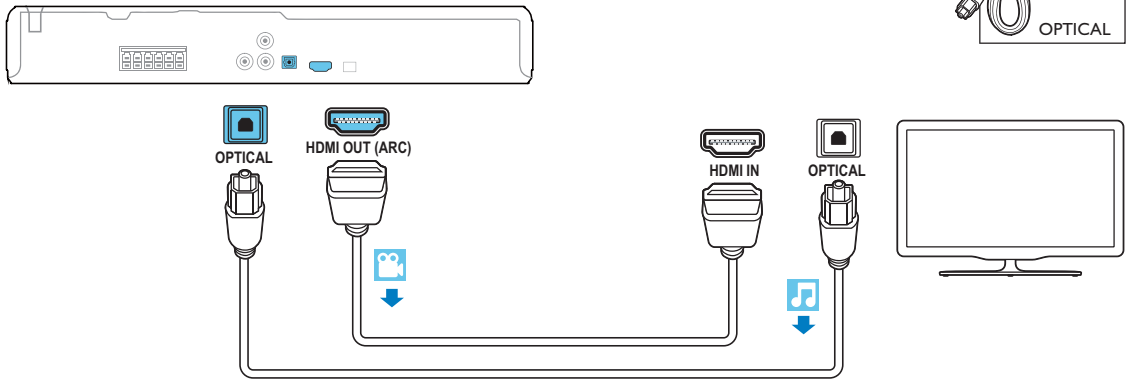

VIDEO + AUDIO L/R

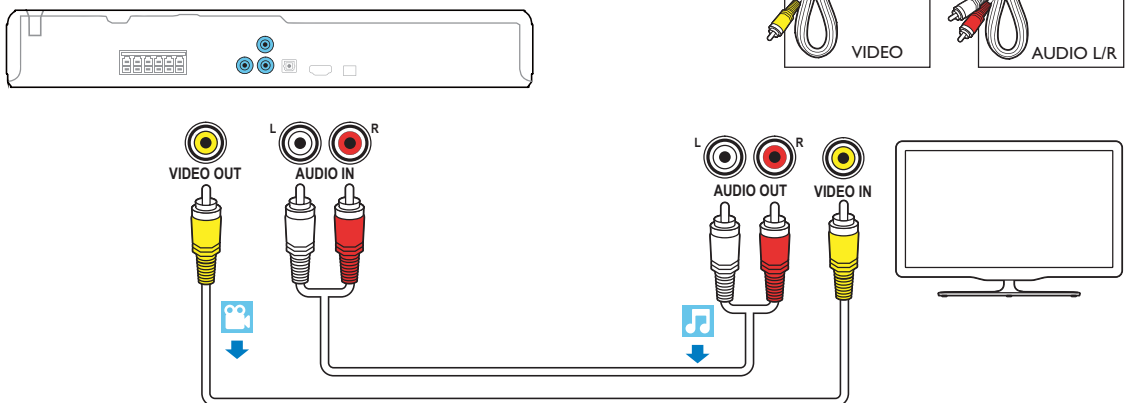

4

EN Switch on the home theater

DA Tænd for hjemmebiografen

DE Einschalten des Home Entertainment-Systems

EL Ενεργοποιήστε το home cinema

ES Enciende el sistema de cine en casa

FI Virran kytkeminen kotiteatteriin

FR Mettre sous tension le Home Cinéma

IT Accensione del sistema Home Theater

NL Schakel de home cinema in

NO Slå på hjemmekinoanlegget

PT Ligar o sistema de cinema em casa

SV Sätt på hemmabiosystemet

TR Ev sinemasını açın

CS Zapněte domácí kino

HU A házimozi bekapcsolása

PL Włączenie zestawu kina domowego

RO Porniți sistemul home theater

SK Zapnutie domáceho kina

1

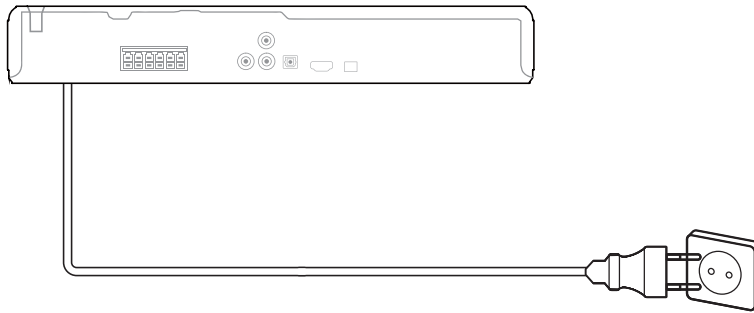

2

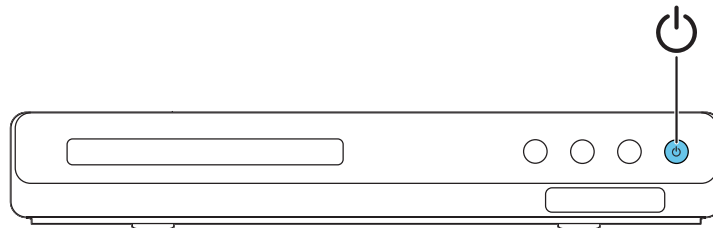

3

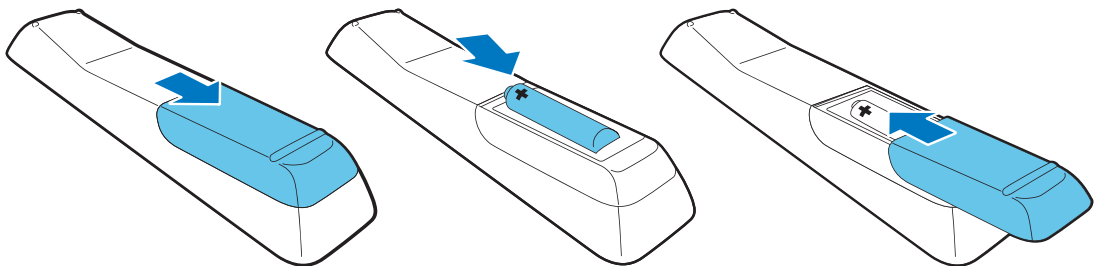

5

EN Complete the first time setup

DA Fuldfør den indledende opsætning

DE Abschließen der Ersteinrichtung

EL Ολοκληρώστε τη ρύθμιση για πρώτη φορά

ES Finaliza la configuración inicial

FI Ensiasennuksen suorittaminen loppuun

FR Effectuer la configuration initiale

IT Completamento della configurazione iniziale

NL Voltooi de eerste installatie

NO Fullfør den første konfigureringen

PT Executar a configuração inicial

SV Slutför förstagångsinställningen

TR İlk kullanım öncesi kurulumunu tamamlayın

CS Dokončili jste nastavení při prvním zapnutí

HU Az első üzembe helyezés

PL Pierwsza konfiguracja

RO Realizați prima configurare

SK Dokončenie prvého nastavenia

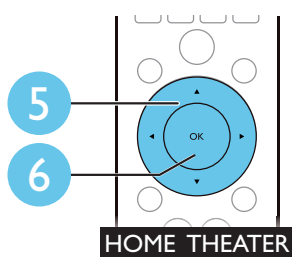
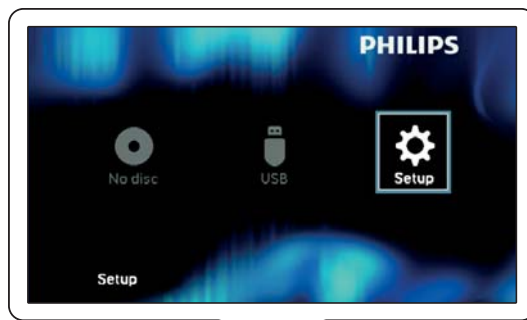
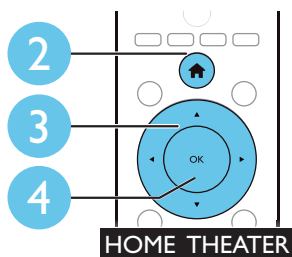
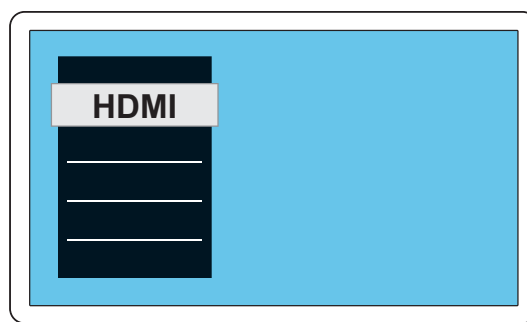
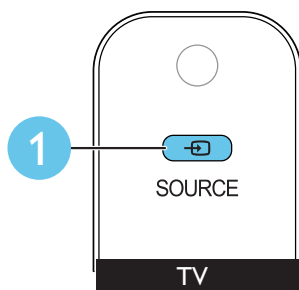

6

EN Use your home theater

DA Brug af din hjemmebiograf

DE Verwenden des Home Entertainment-Systems

EL Χρησιμοποιήστε το home cinema

ES Uso del sistema de cine en casa

FI Kotiteatterin käyttäminen

FR Utiliser votre Home Cinéma

IT Utilizzo del sistema Home Theater

NL Uw home cinema bedienen

NO Bruke hjemmekinoanlegget

PT Utilizar o sistema de cinema em casa

SV Använda hemmabiosystemet

TR Ev sinema sisteminin kullanılması

CS Použití domácího kina

HU A házi mozi használat

PL Korzystanie z zestawu kina domowego

RO Utilizați sistemul home theater

SK Používanie domáceho kina

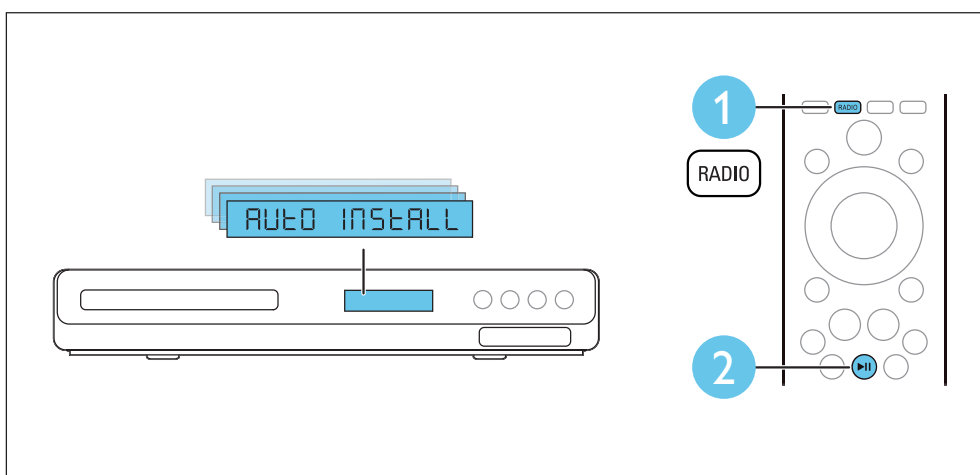
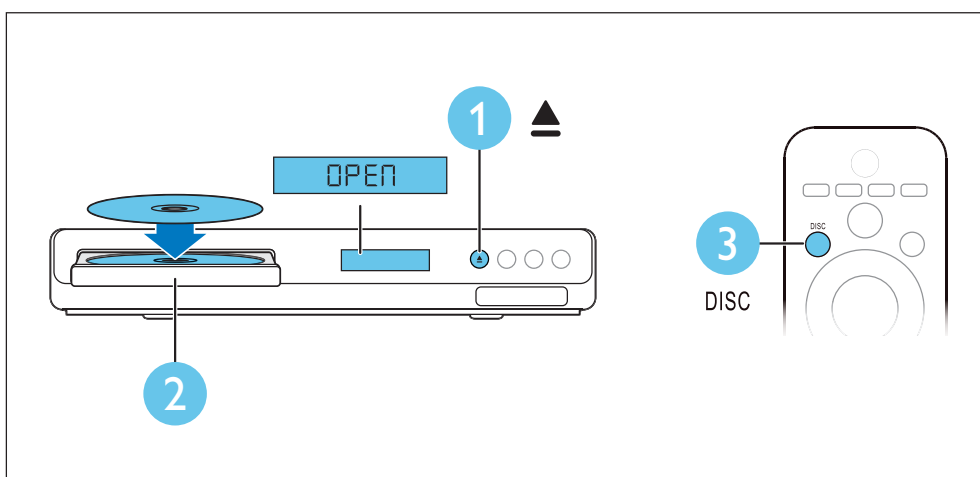

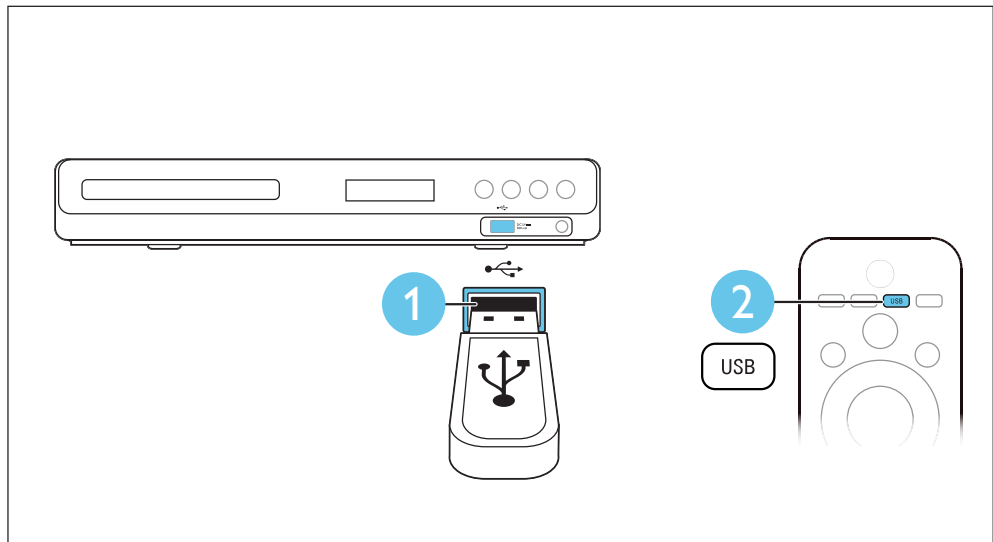
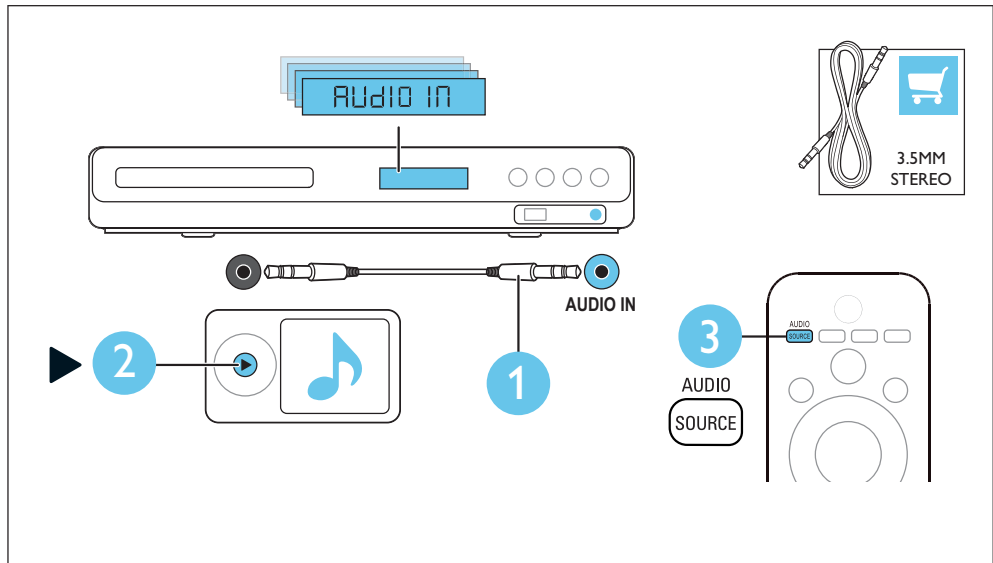

Mechanical and Dismantling Instructions

Dismantling Instruction

Detailed information please refer to the model set.

The following guidelines show how to dismantle the player.

Step1: Open the top cover. Remove 2 screws on both sides and 4 screws on back panel, then open the cover.
(Figure 1)

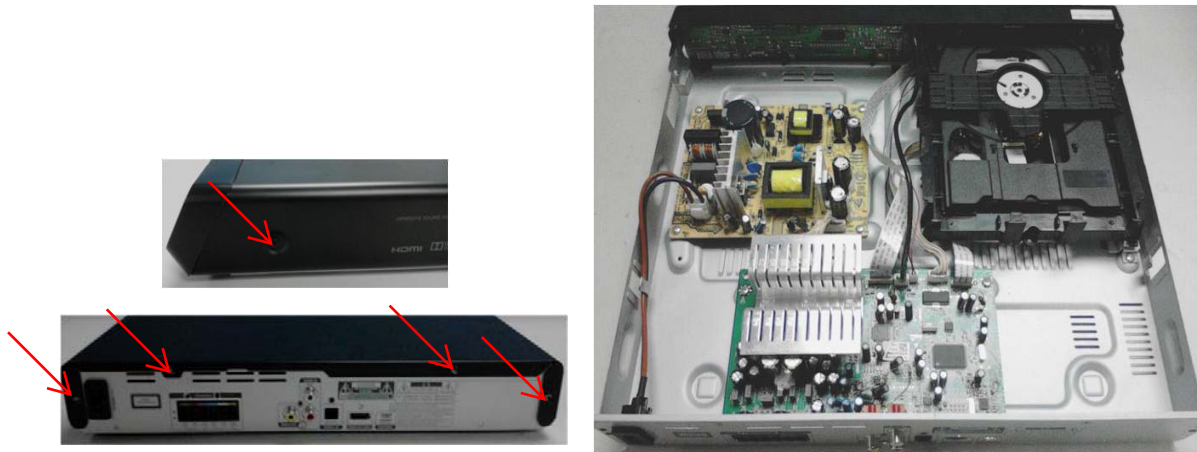

Figure 1

Step2: Dismantle the loader. Open the tray, dismantle the CD door, remove 2 screws beside the loader. disconnect connectors(XP100,XP135,XP136), then pull up the loader.(Figure 2)



Figure 2

Mechanical and Dismantling Instructions

Dismantling Instruction

Detailed information please refer to the model set.

The following guidelines show how to dismantle the player.

Step3: Dismantle the main board. Disconnect connectors(XP221,XP82,XS751),remove 2 screws on the board and 6 screws on back panel.(Figure 3)

Step4: Dismantle the power board.Remove 4 screws on the board.(Figure 3)

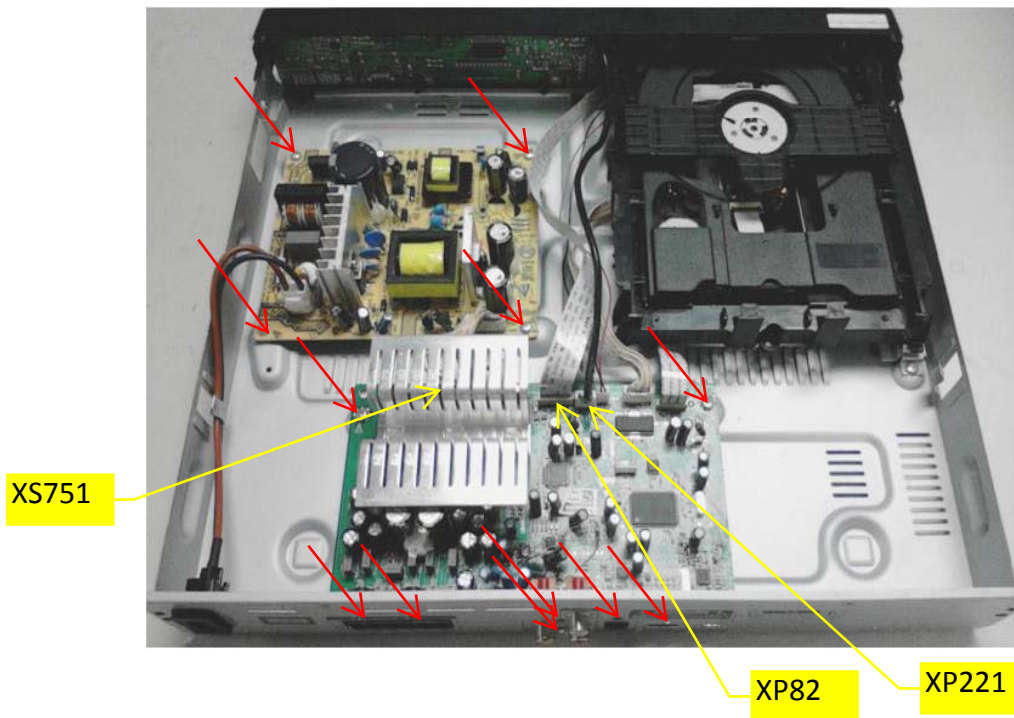

Figure 3

Step5: Dismantle the front panel and the front control board. Loosen the 2 buckles on both sides and 2 buckles under bottom cover, then remove 5 screws on the front control board(Figure 4)

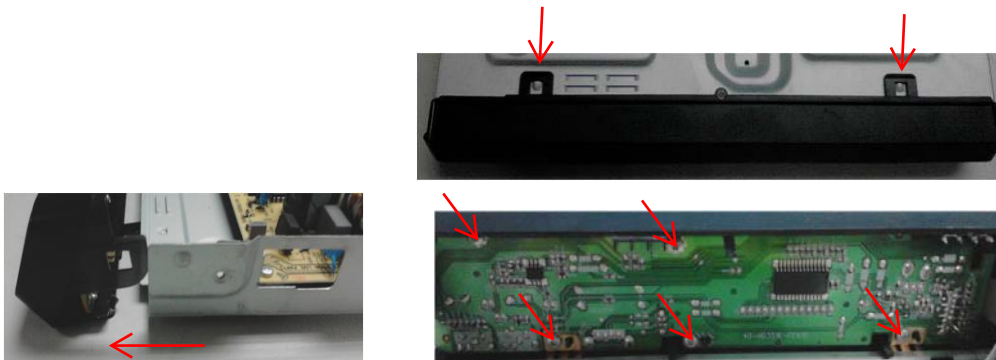

Figure 4

Software Upgrade

1. There are 2 ways to software upgrade:

First:

Upgrade from USB:

Copy the upgrade file HTD3510_XX.BIN to USB then press the USB key on RC or SOURCE key on front panel.

When upgrade file detected, select "Yes" to upgrade, select "Cancel" to cancel.

After upgrading begins, a message "DO NOT POWER OFF" will show, or the product will hang up and upgrading failed.

Second:

Upgrade from Disc:

Copy the upgrade file HTD3510_XX.BIN to disc then read the disc.

When upgrade file detected, select "Yes" to upgrade, select "Cancel" to cancel.

After upgrading begins, a message "DO NOT POWER OFF" will show, or the product will hang up and upgrading failed.

2. Check the version information after upgraded.

Press the setup key on RC , select Preference Setup, and then Version info , press OK Key you will see a interface below:

Preference	
File Name	HTD3510_12.BIN
Version	12.13.218.13
8203RX	19.85.05.16
RISC	026.5BXC 03R-A-026
Servo	DL0DL2-FAA-774X
Region Code	2
OK	

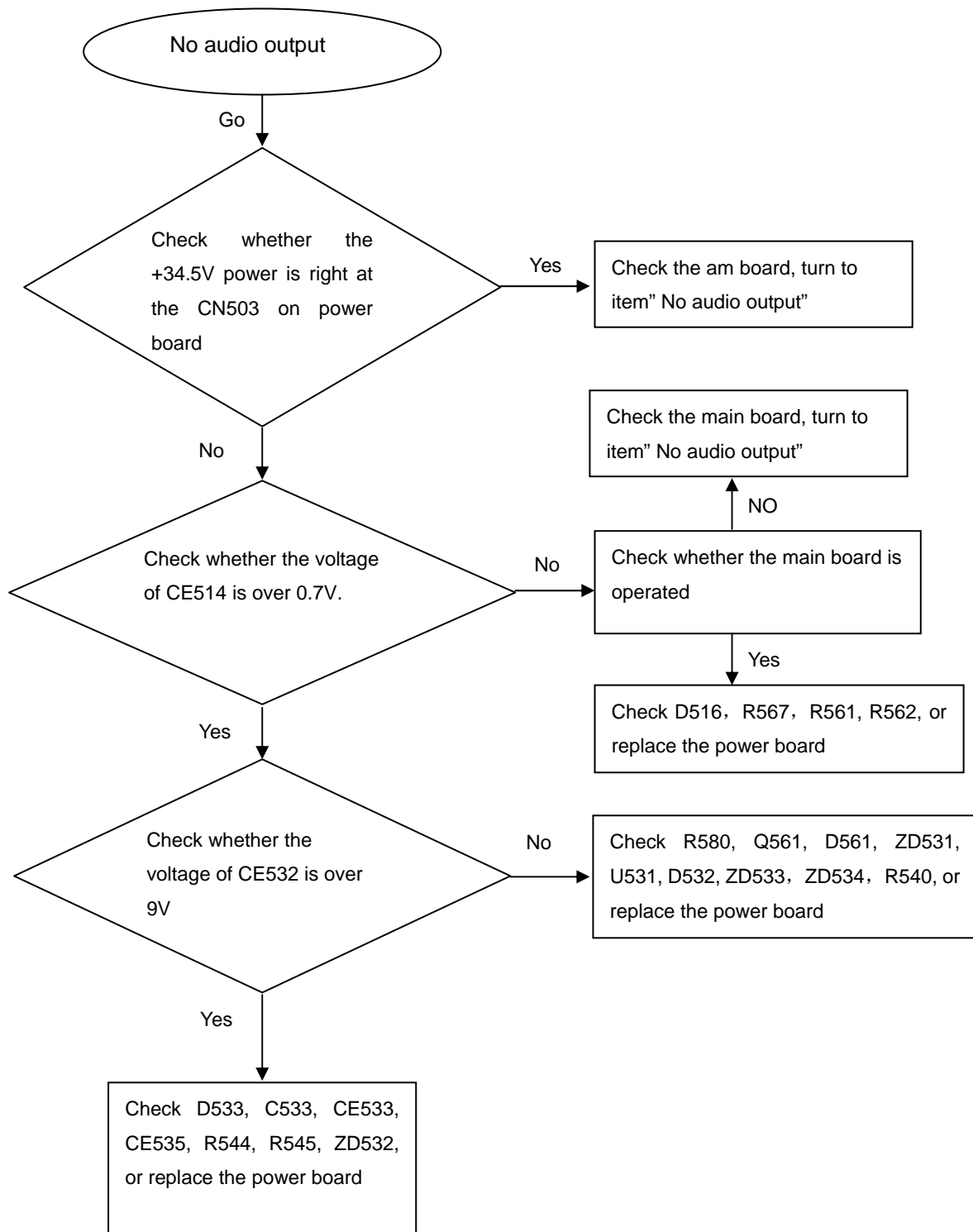
No audio output (Check the power board)

No display on VFD, and buttons do not work (Check the power board)

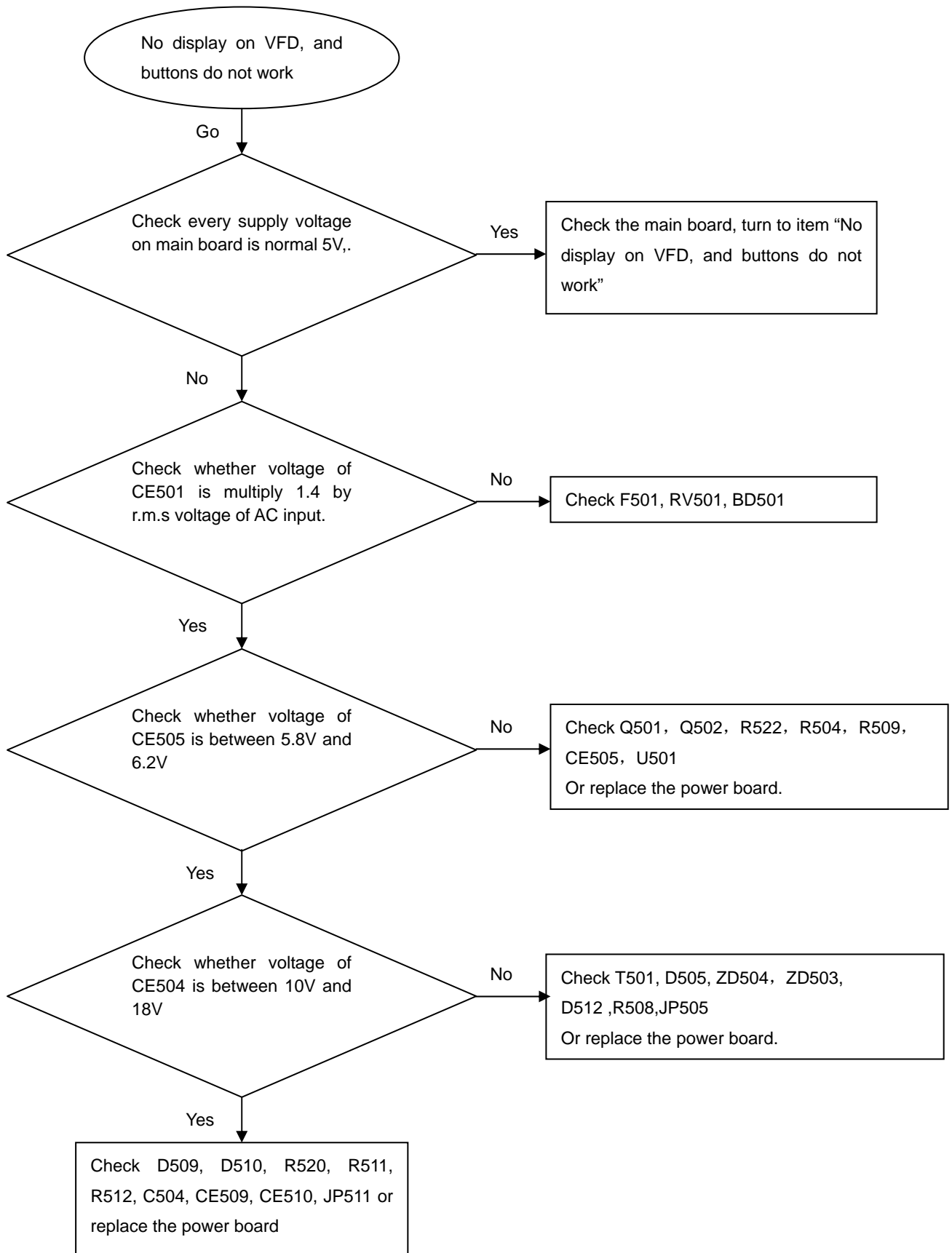

No display on LED, and buttons do not work

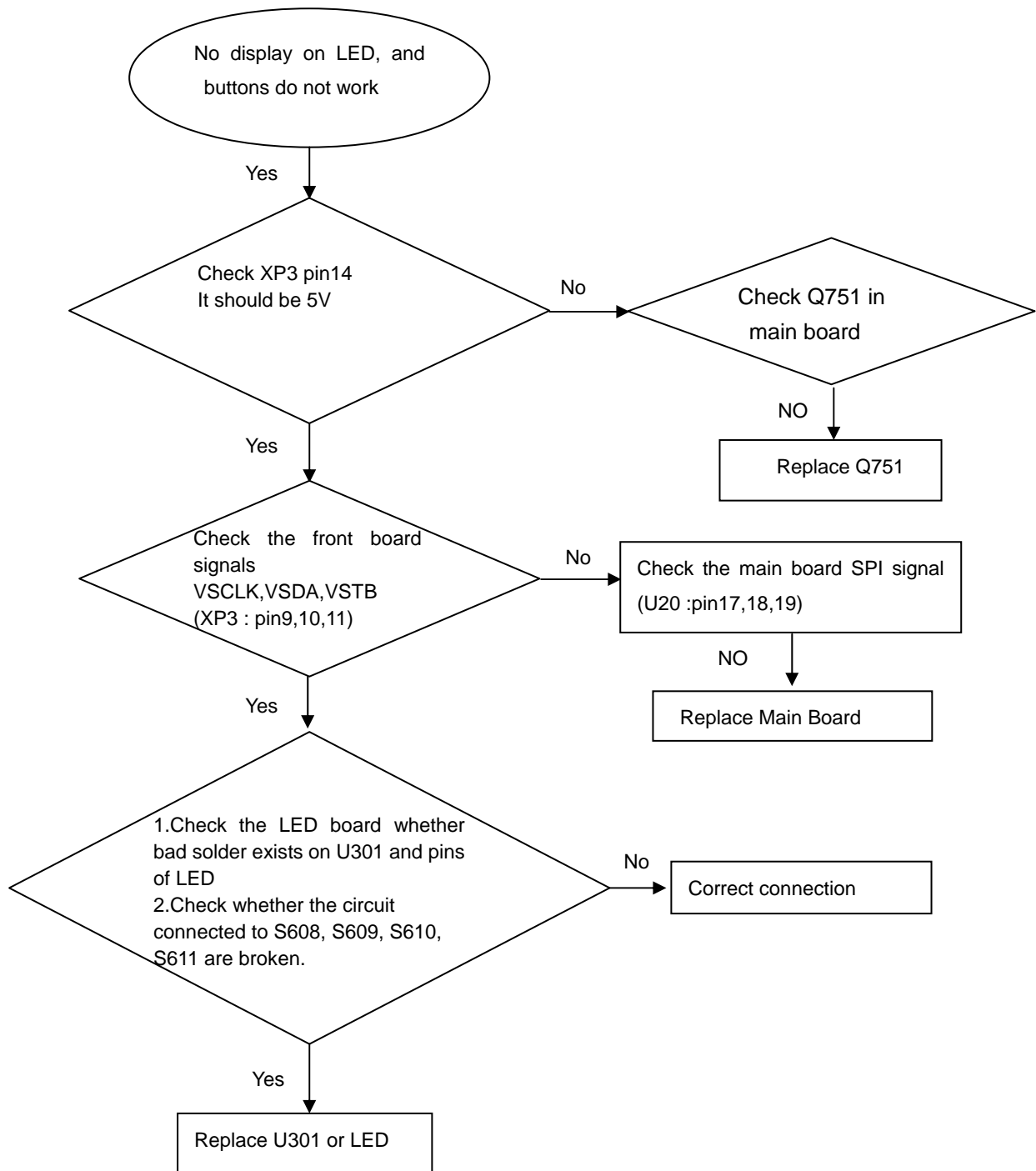

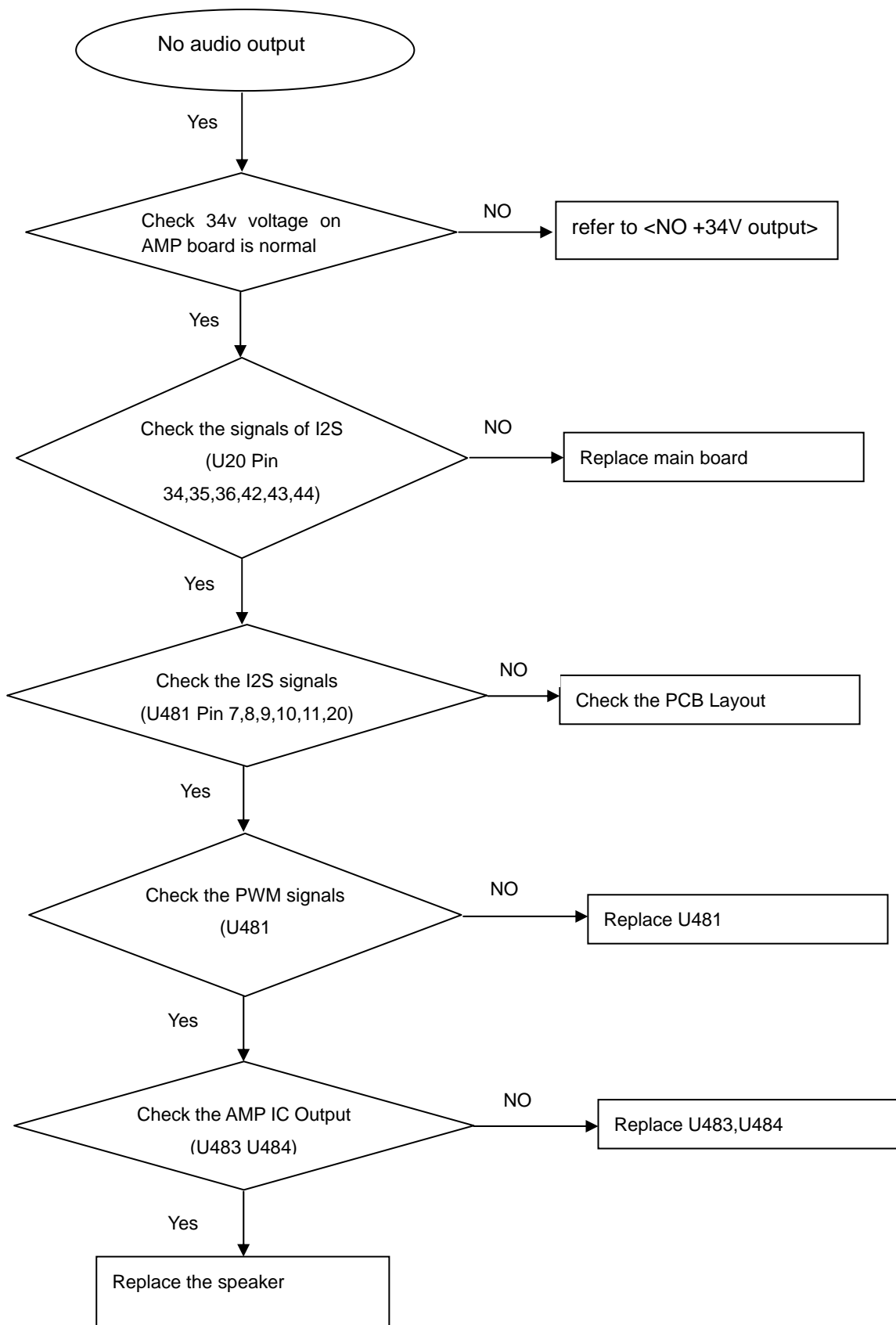
No audio output

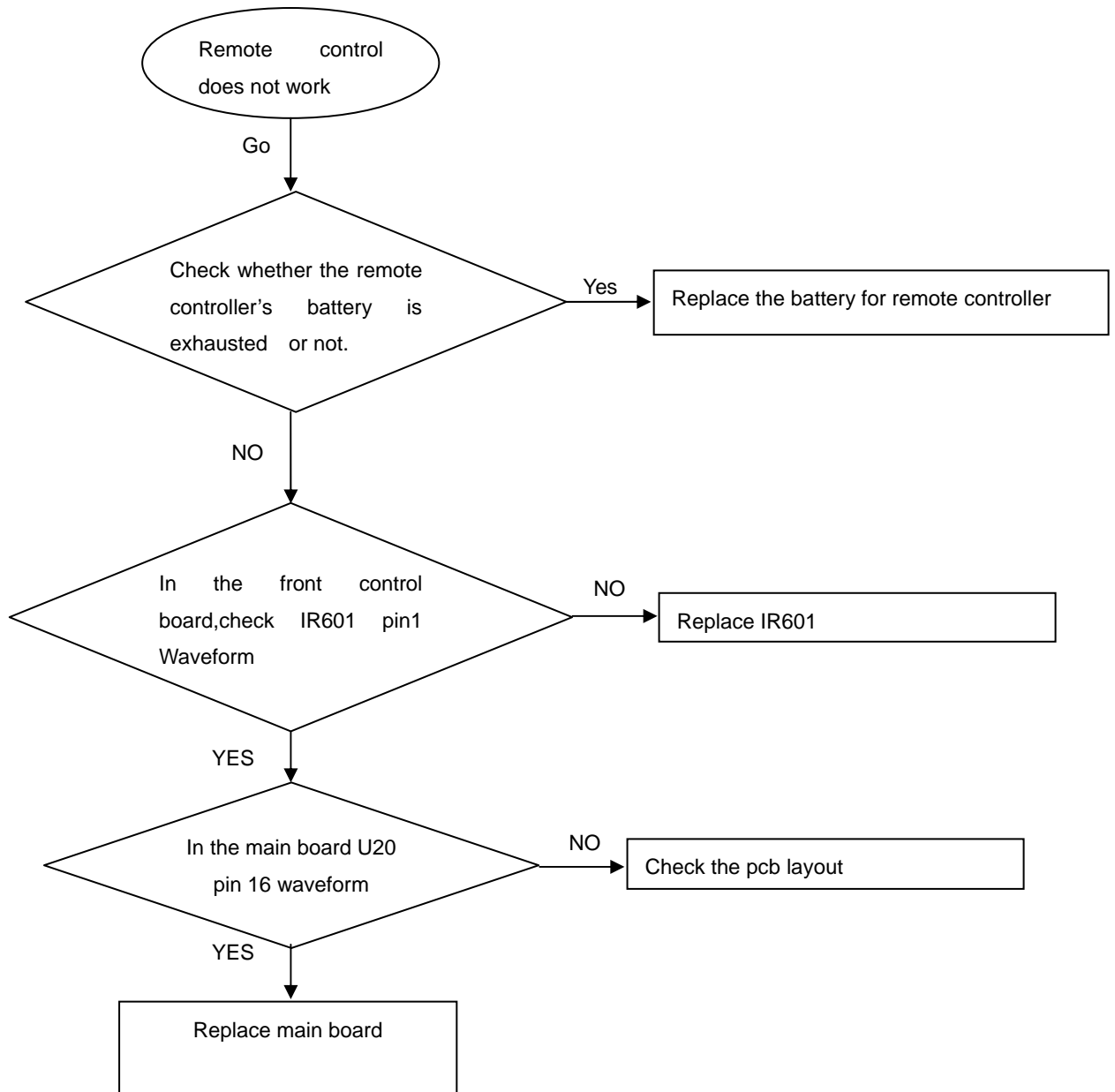
Remote control does not work

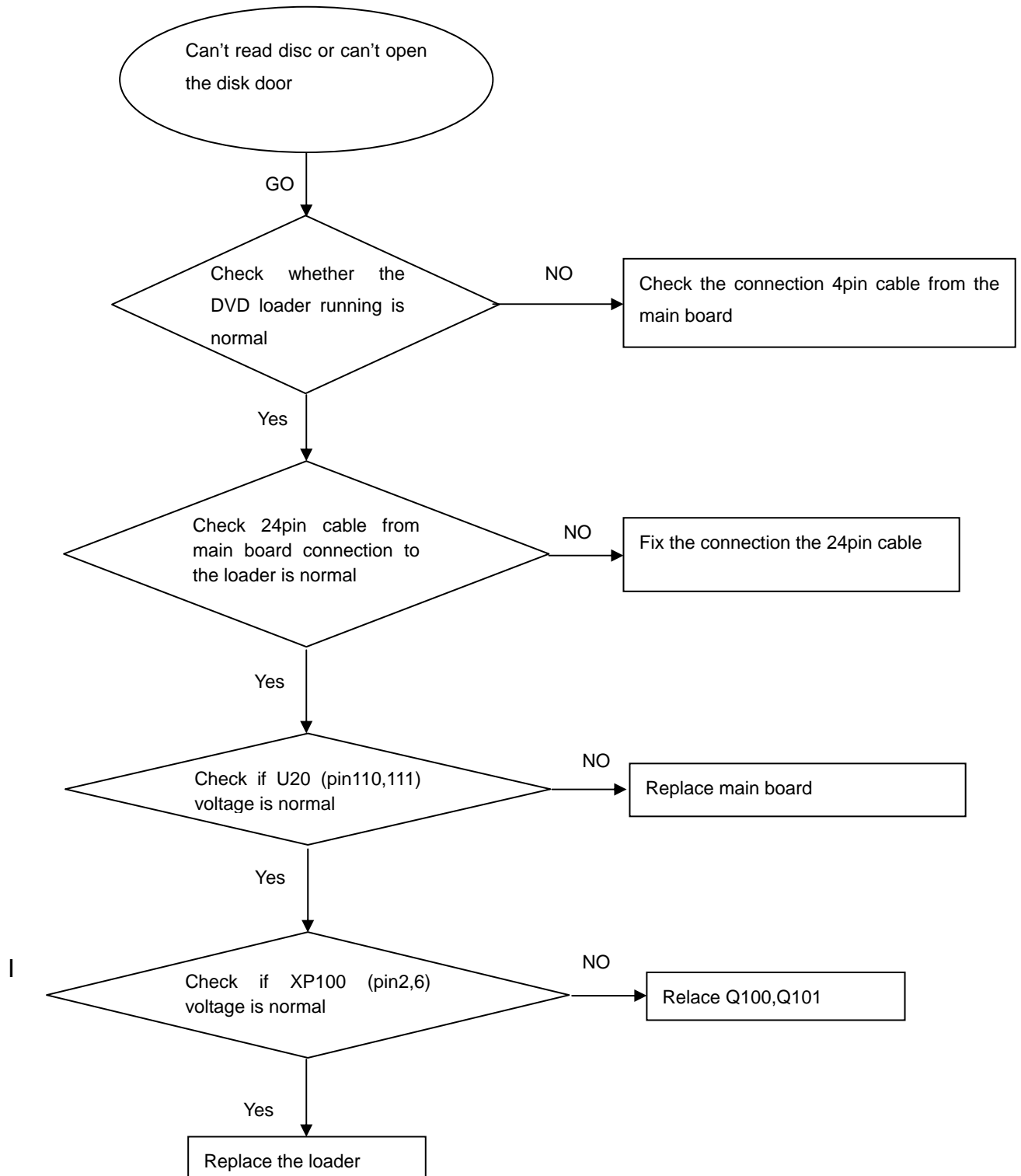
Can't read disc or can't open the disk door

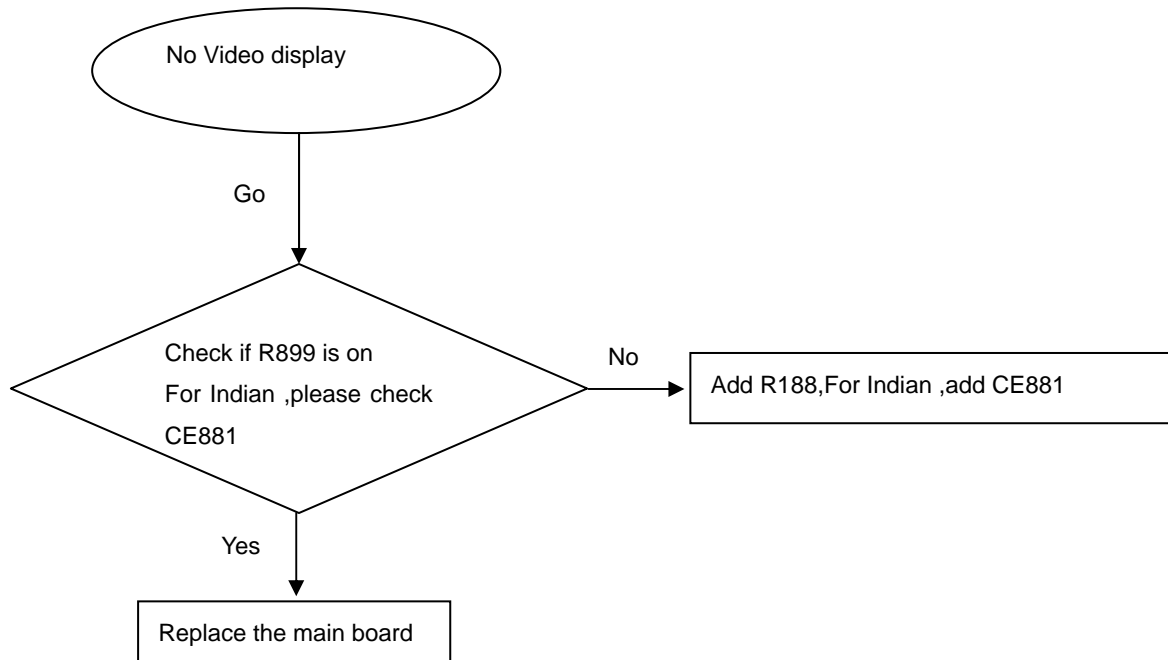
No video display

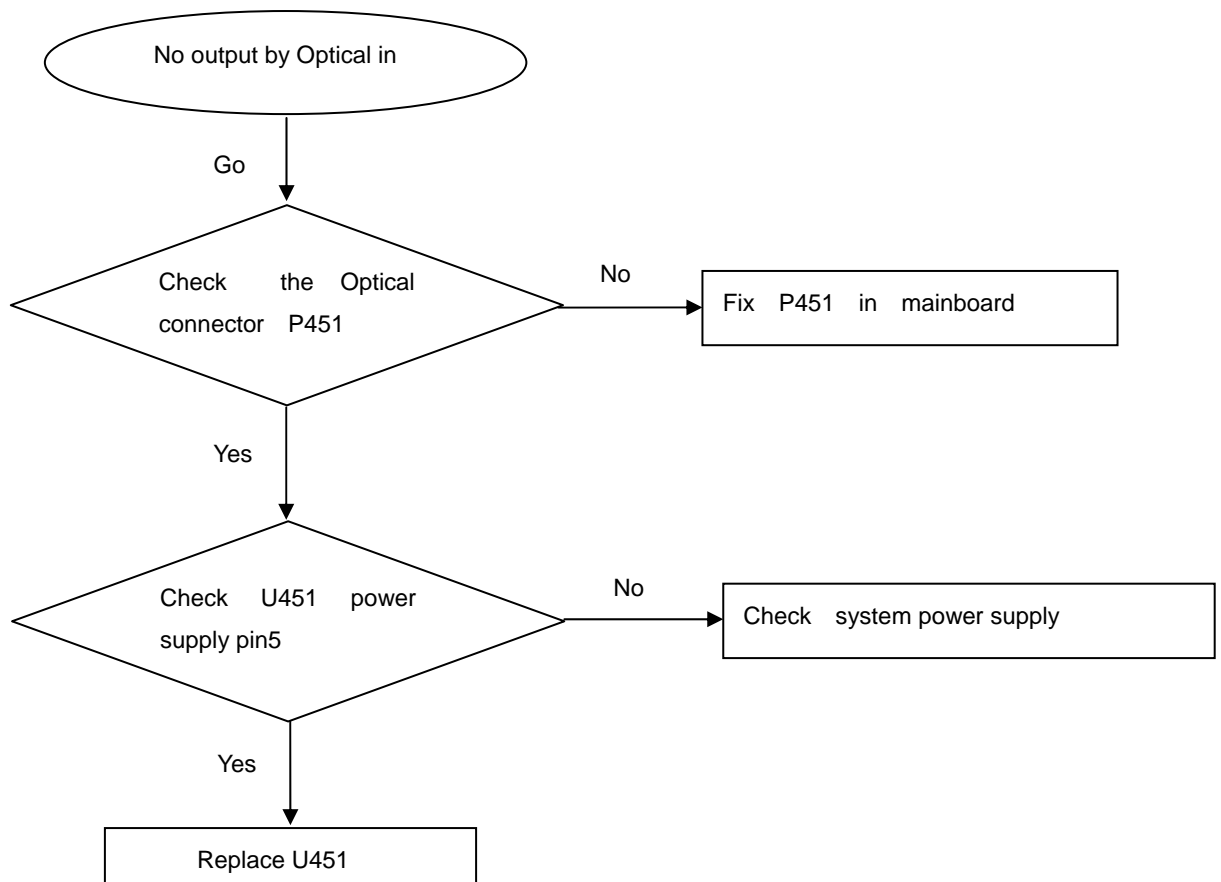
No output by Optical in

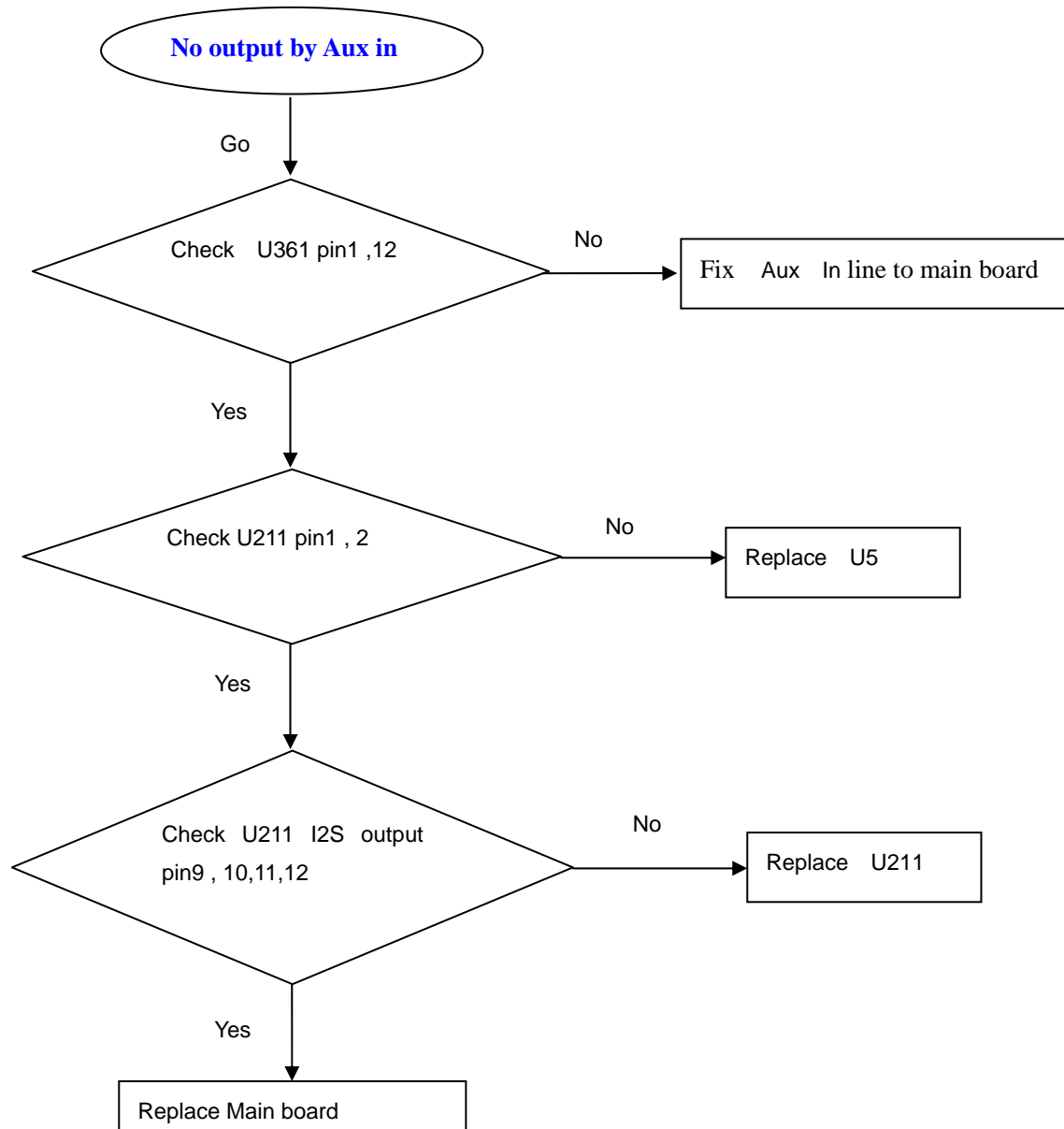
No output by Aux IN

Wiring and Block diagram for HTD3570:

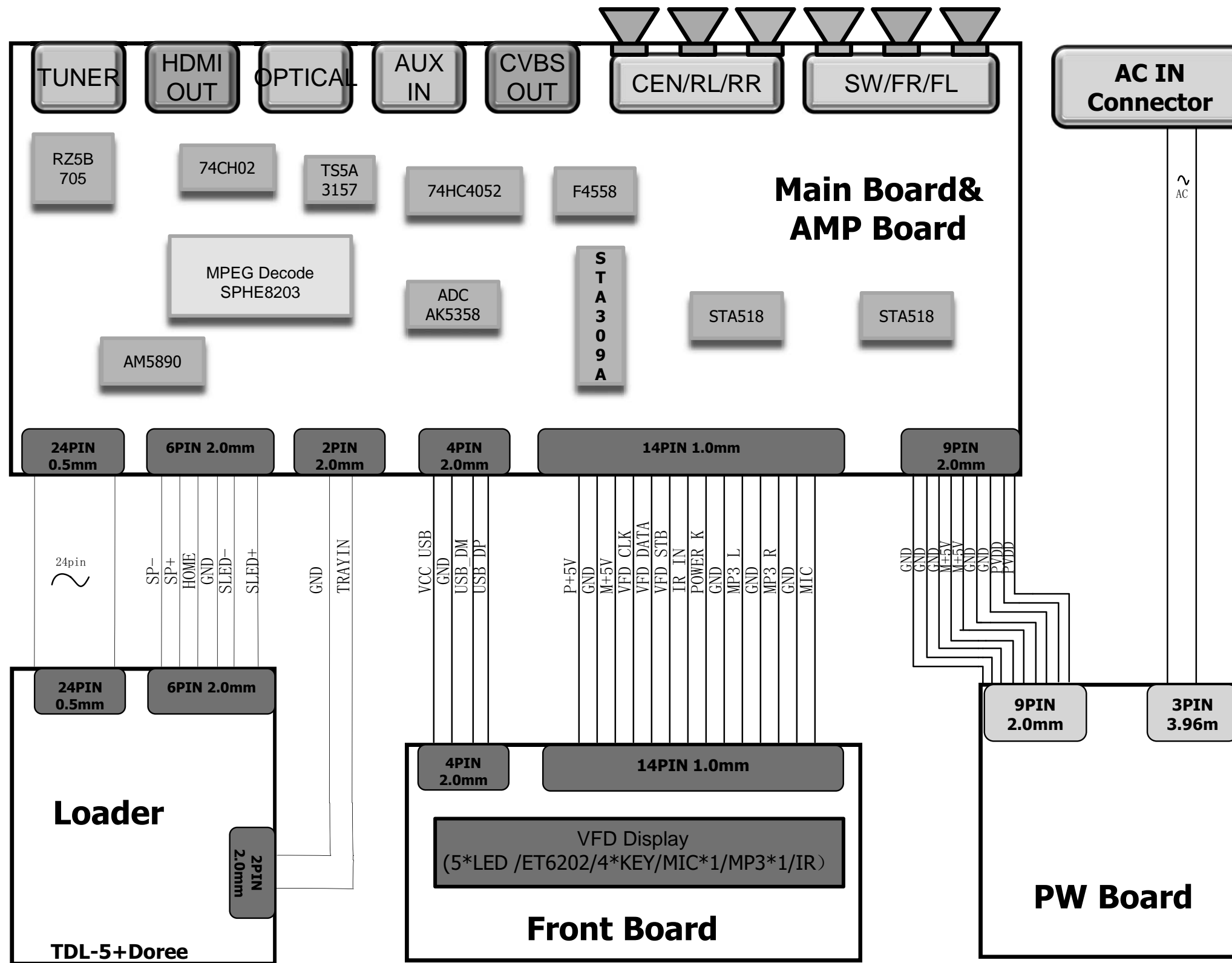

Front Control Board Circuit Diagram:

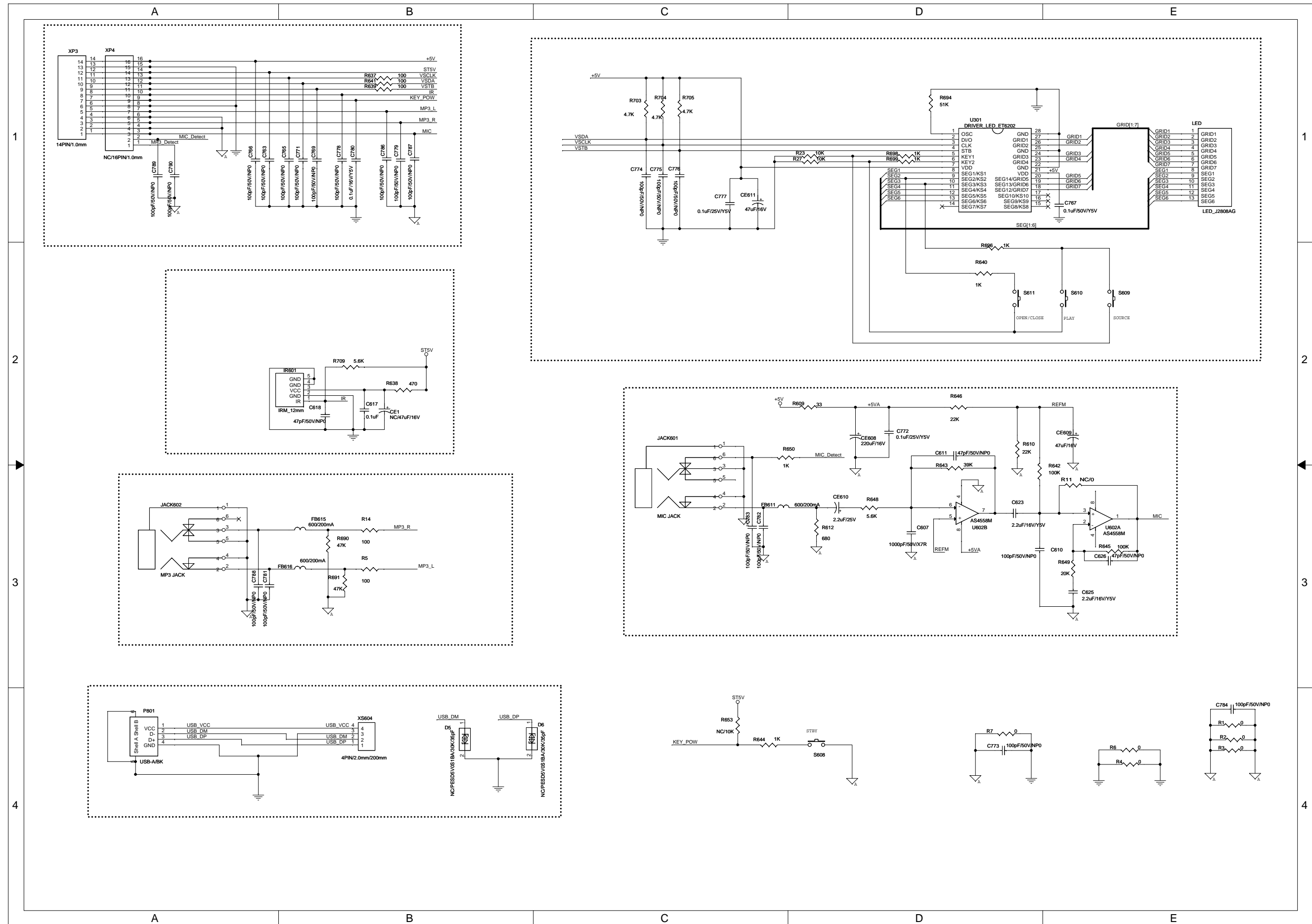

Power Board Circuit Diagram:

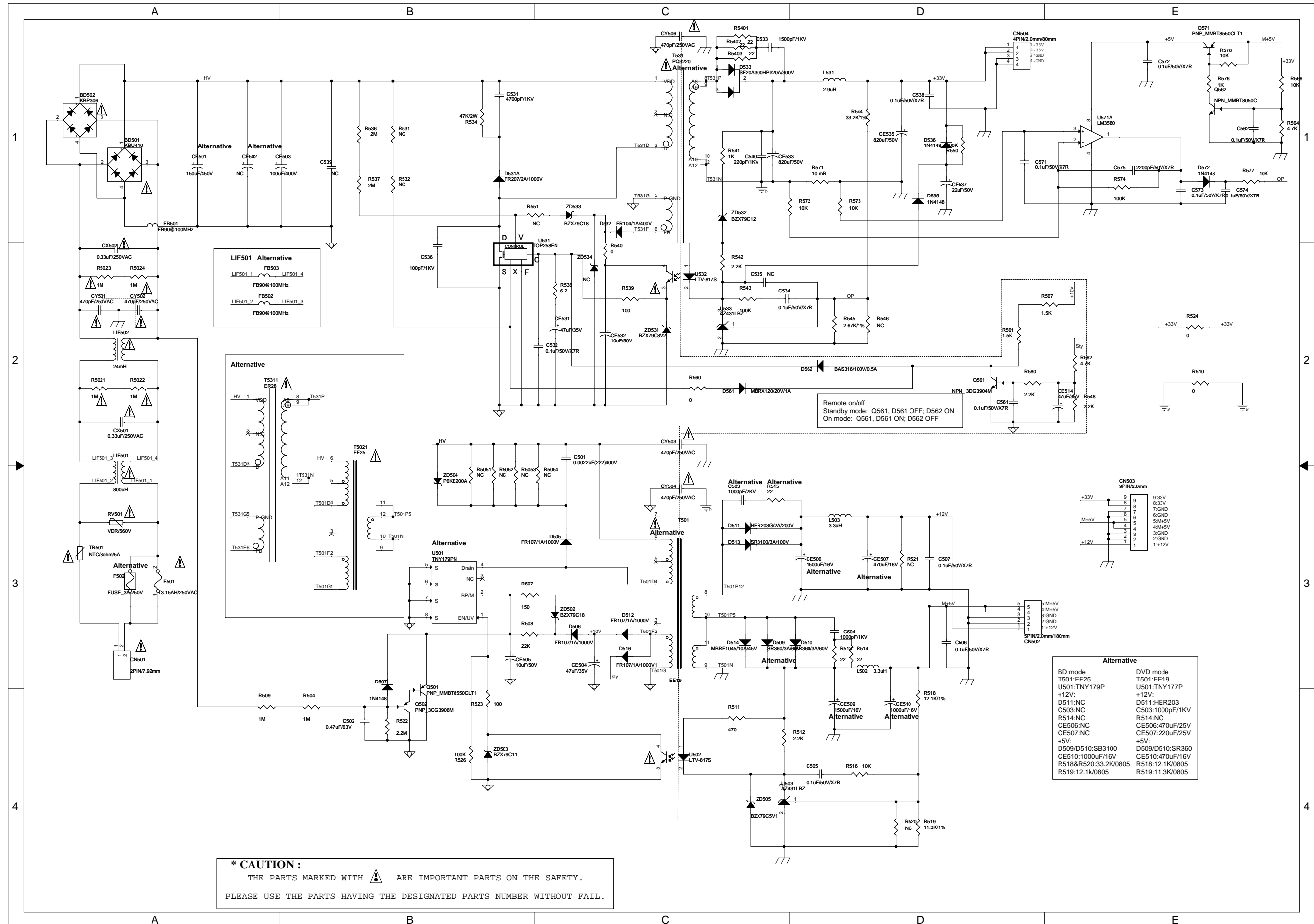

*** CAUTION :**
 THE PARTS MARKED WITH ⚠ ARE IMPORTANT PARTS ON THE SAFETY.
 PLEASE USE THE PARTS HAVING THE DESIGNATED PARTS NUMBER WITHOUT FAIL.

Alternative	
BD mode	DVD mode
T501:EF25	T501:EE19
U501:TNY179P	U501:TNY177P
+12V:	+12V:
D511:NC	D511:HER203
C503:NC	C503:1000pF/1KV
R514:NC	R514:NC
C506:NC	C506:470uF/25V
C507:NC	C507:220uF/25V
+5V:	+5V:
D509/D510:SB3100	D509/D510:SR360
C510:1000uF/16V	C510:470uF/16V
R518&R520:33.2K/0805	R518:12.1K/0805
R519:12.1k/0805	R519:11.3K/0805

Main Board Circuit Diagram: Power

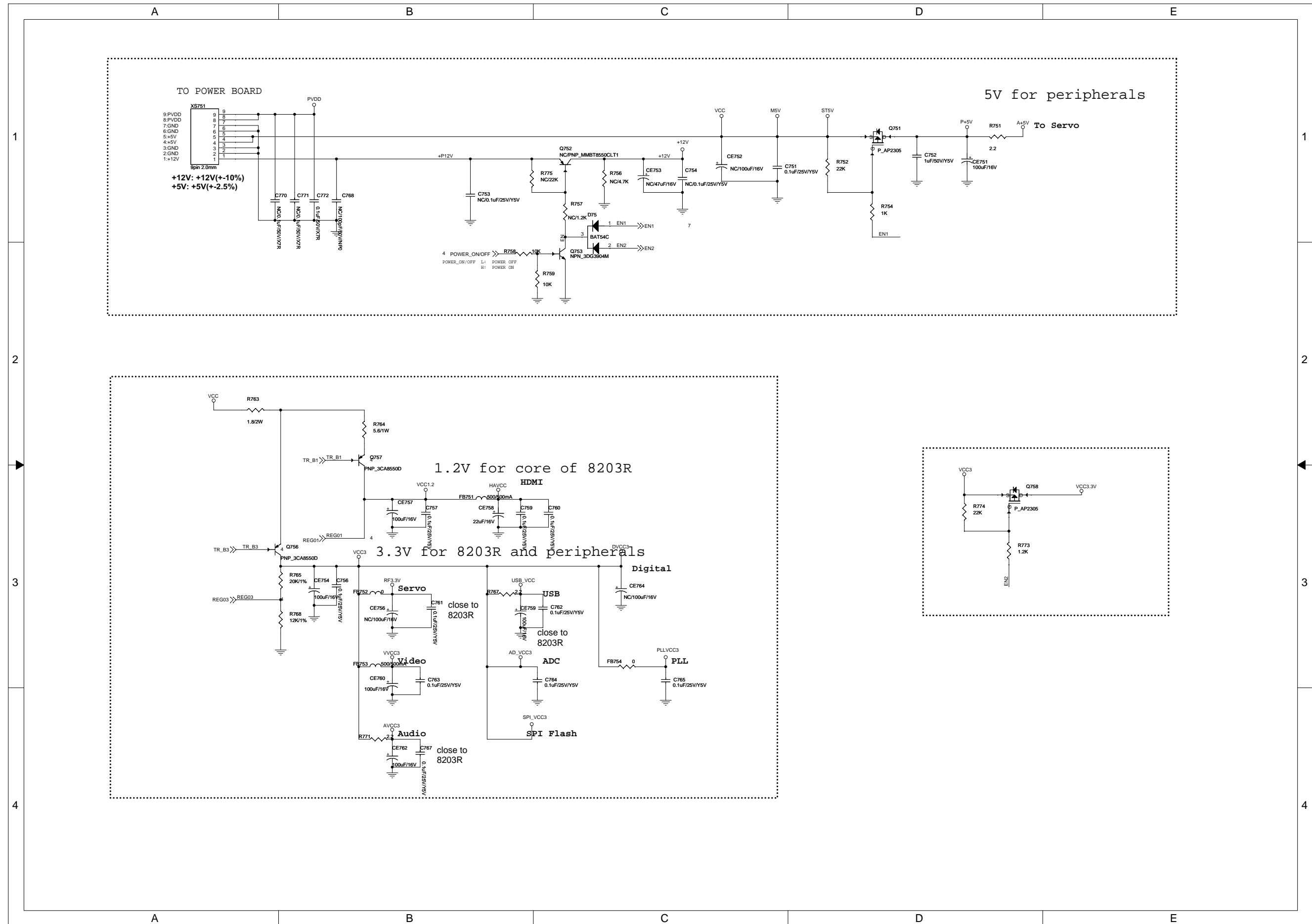

Main Board Circuit Diagram:SPHE8203R

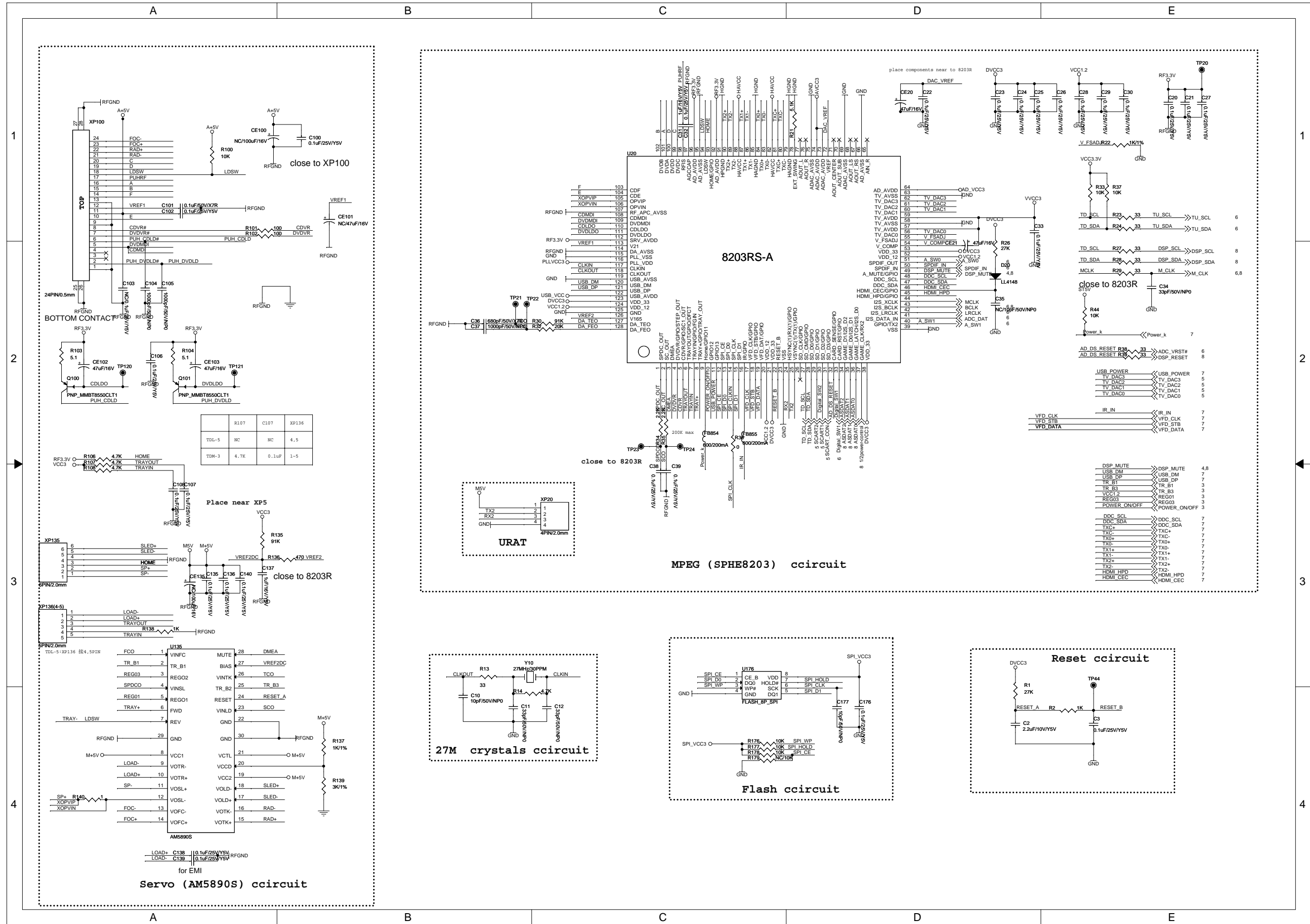

Main Board Circuit Diagram: Analog Video Output

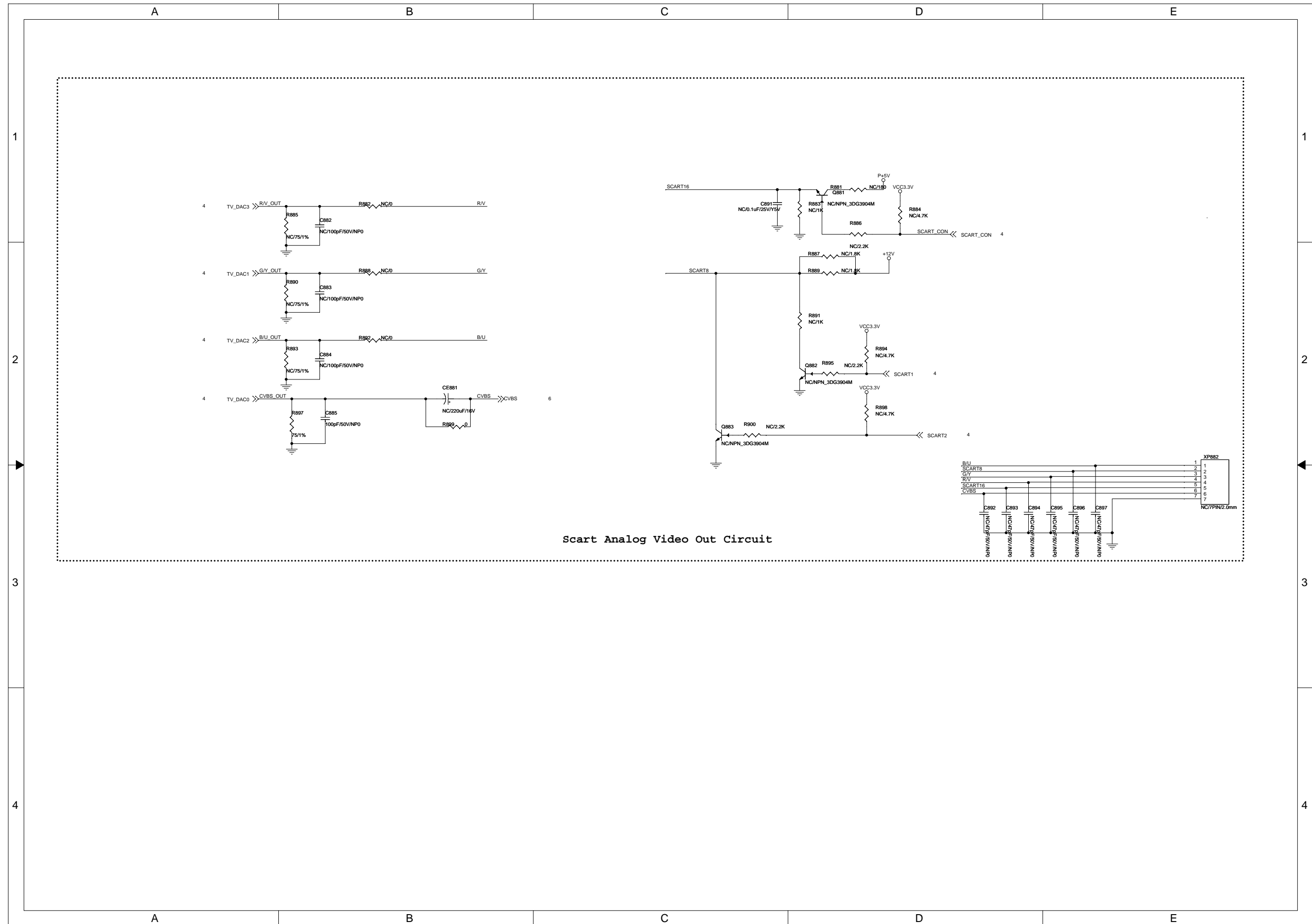

Main Board Circuit Diagram:Audio Input

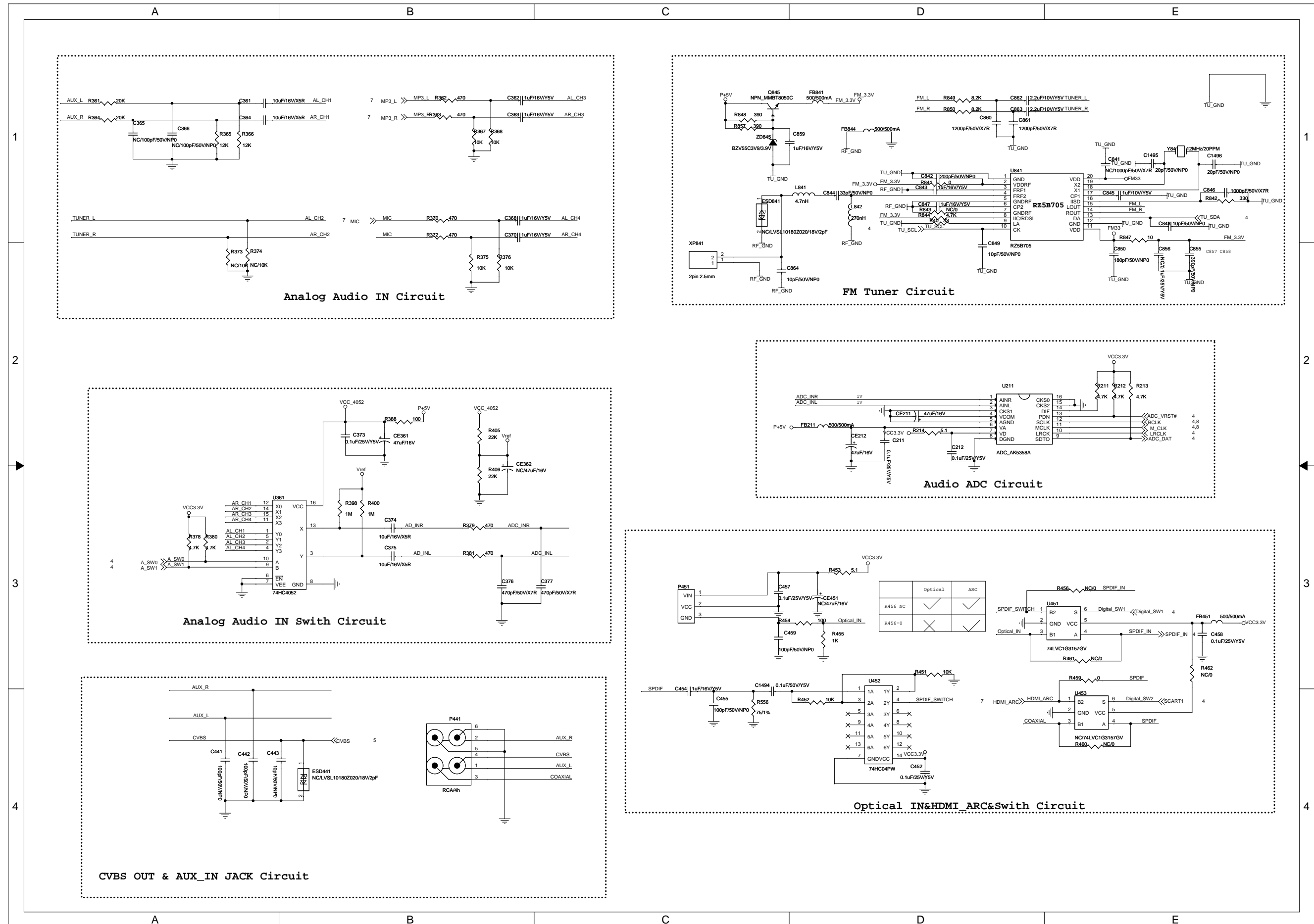

Main Board Circuit Diagram:HDMI&USB

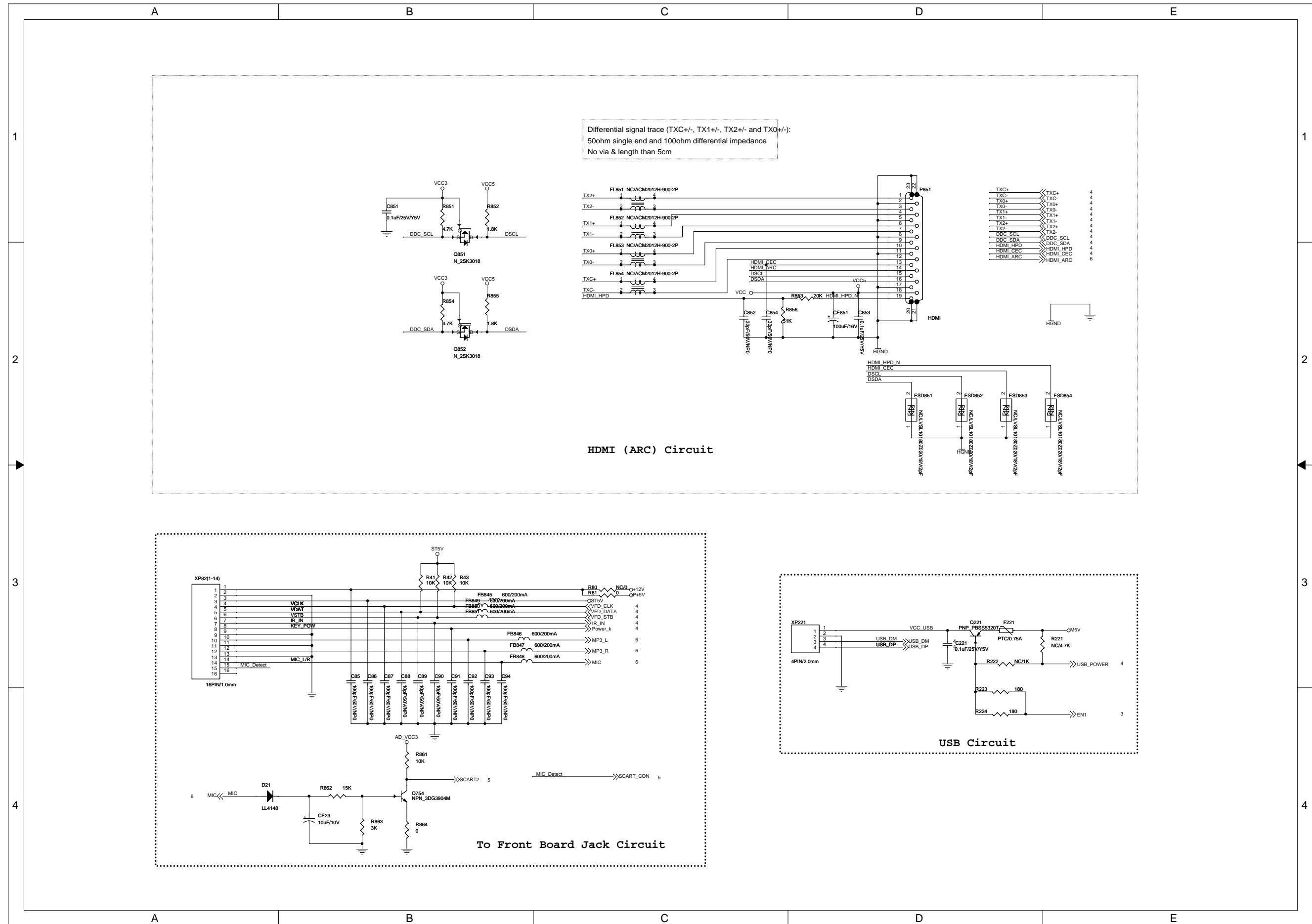

Main Board Circuit Diagram:STA309A

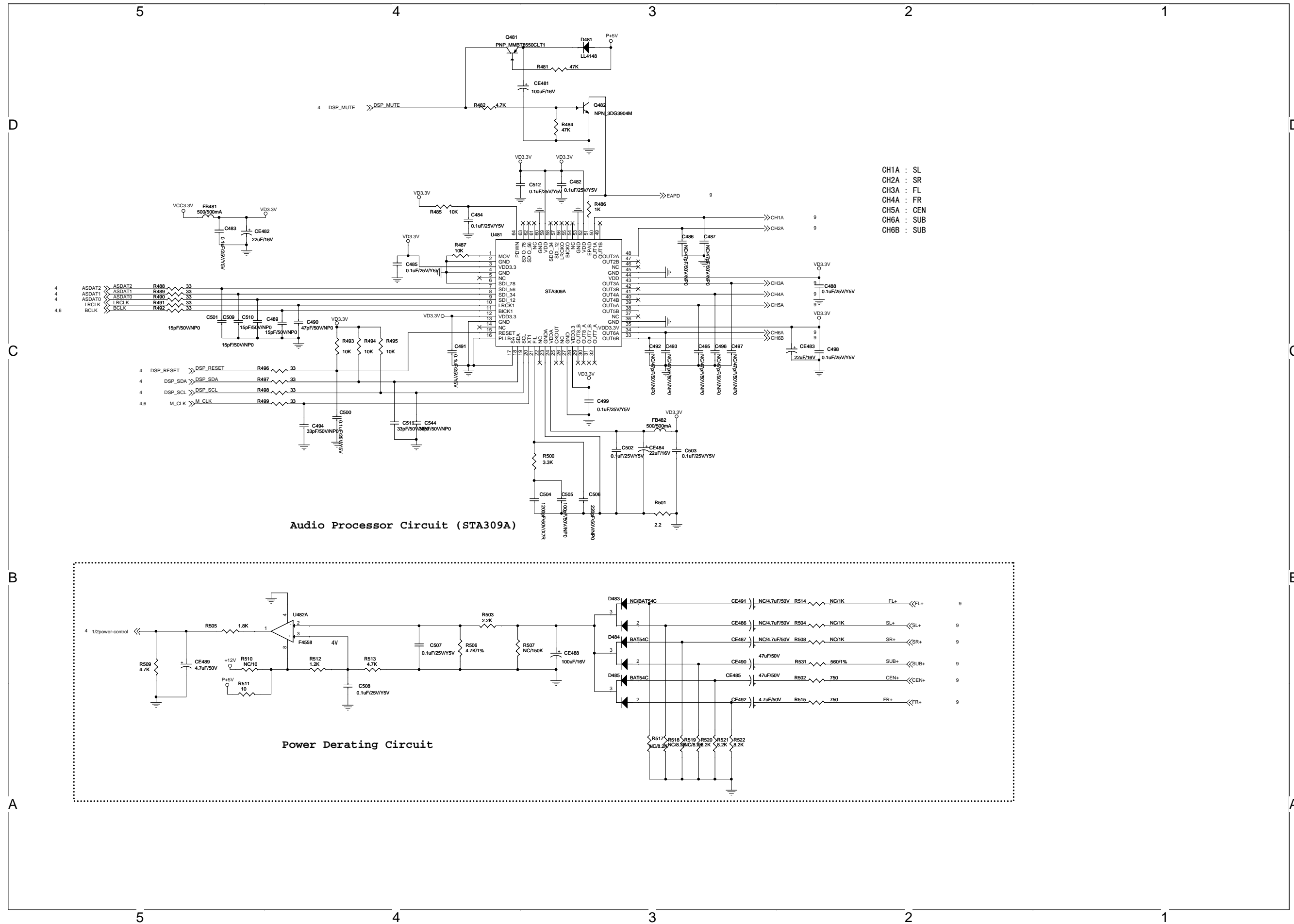

Main Board Circuit Diagram: AMP STA518*2

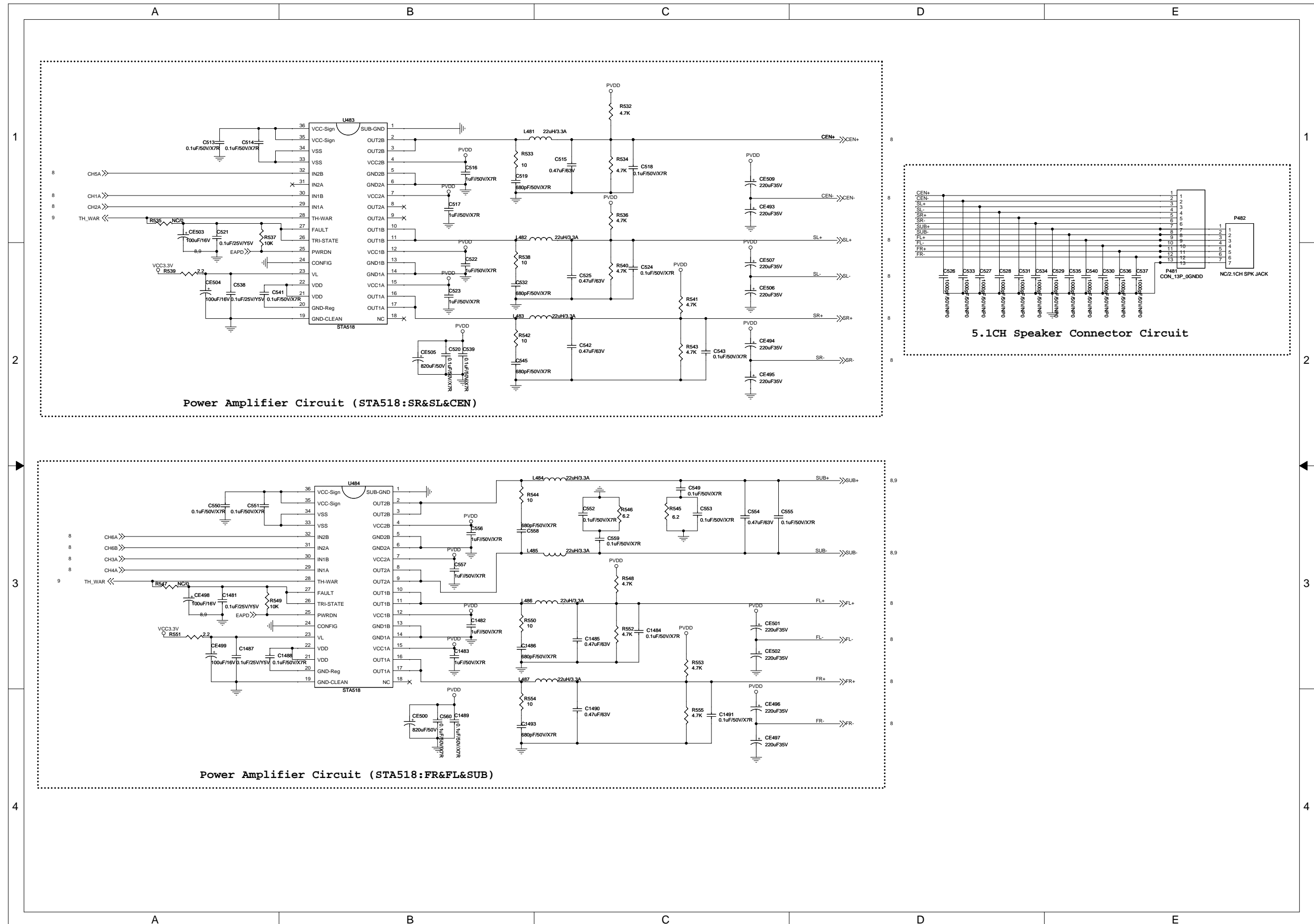

Front Control Board Print-layout(top side):

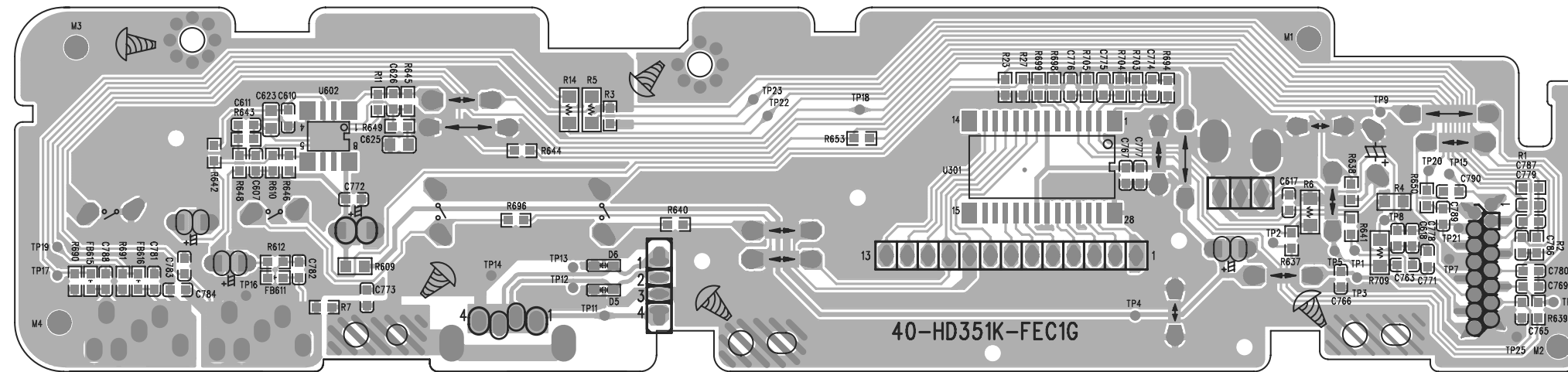

Power Board Print-layout(top side):

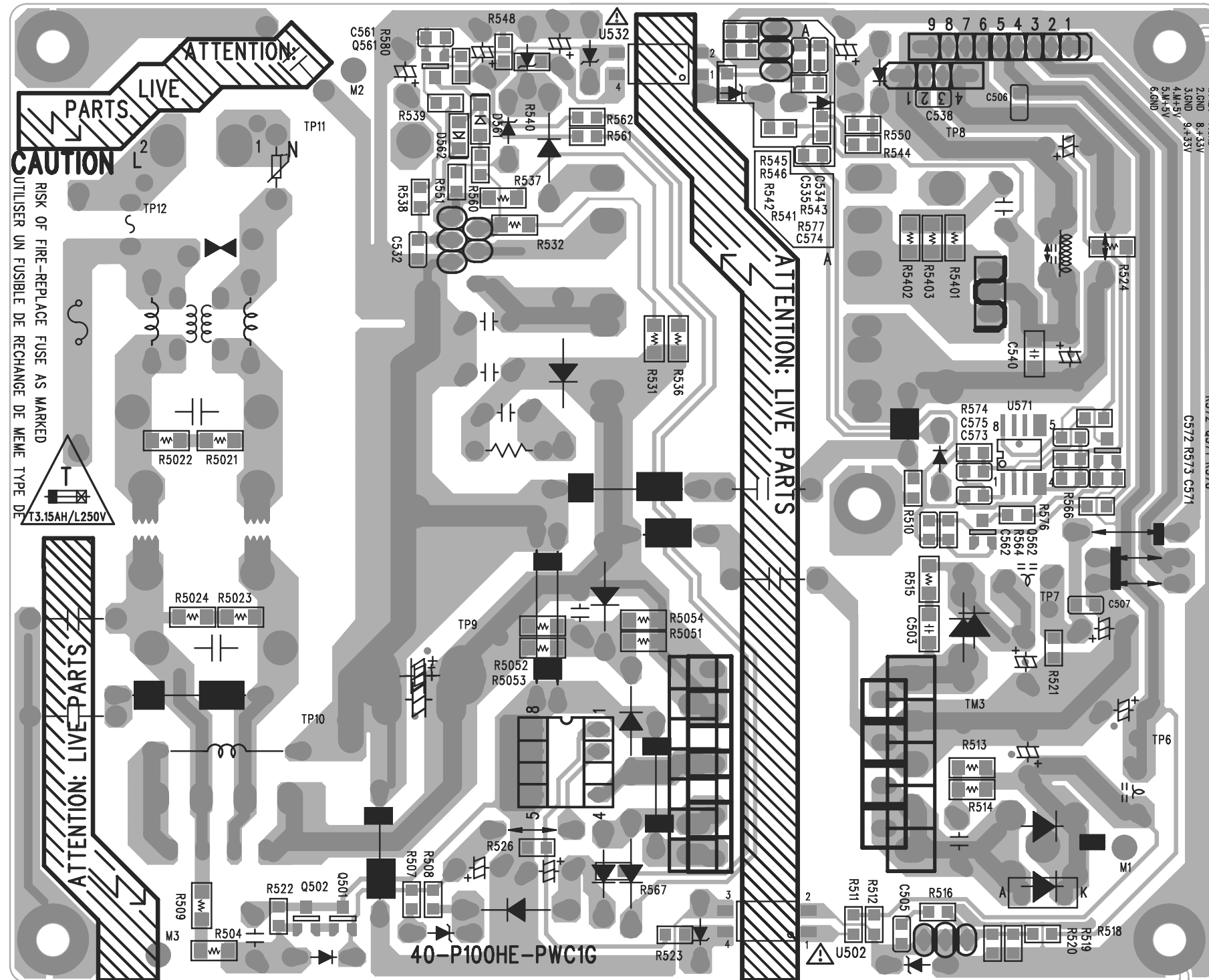

Main Board Print-layout(top side):

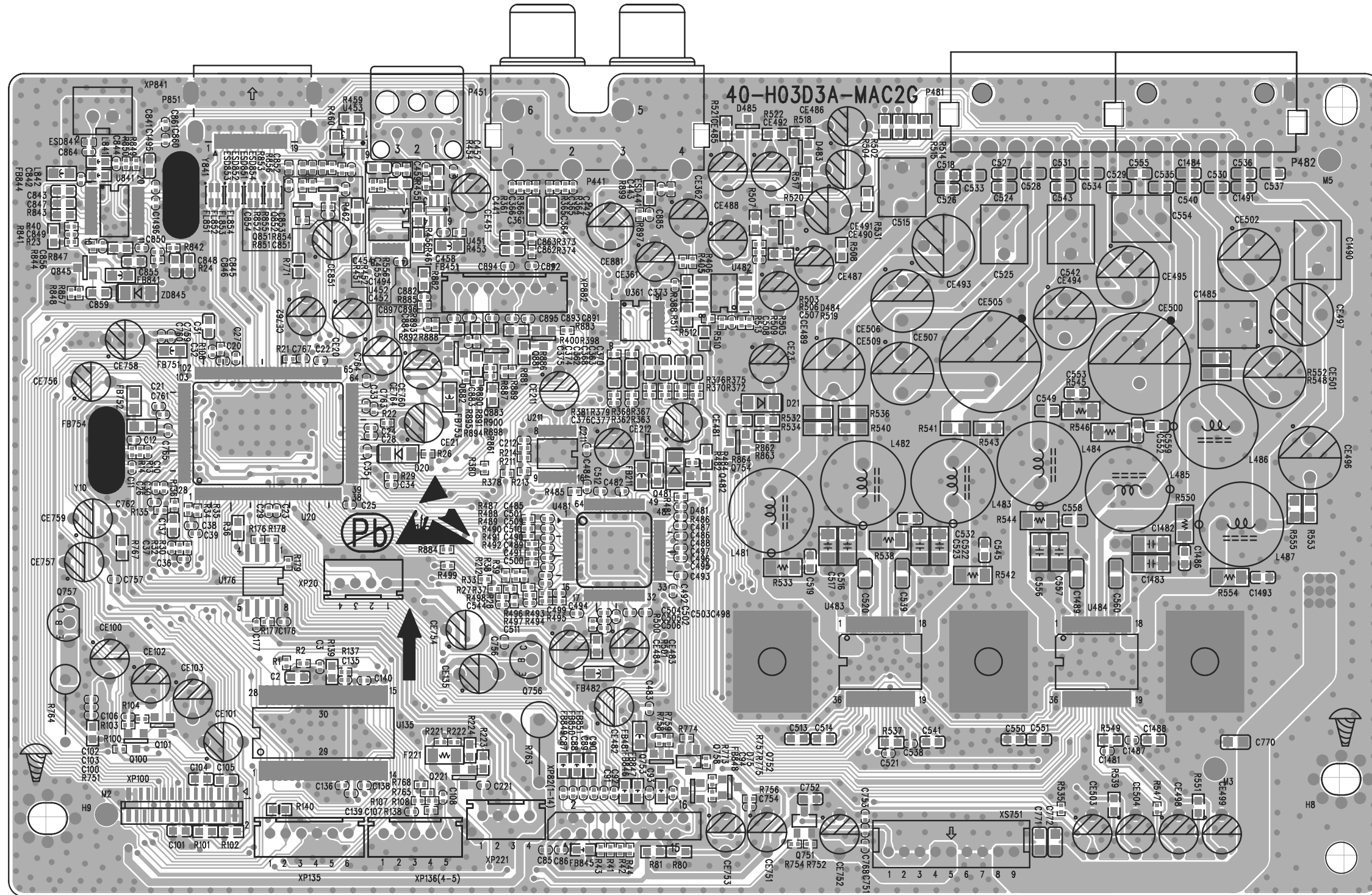

Main Board Print-layout(bottom side):

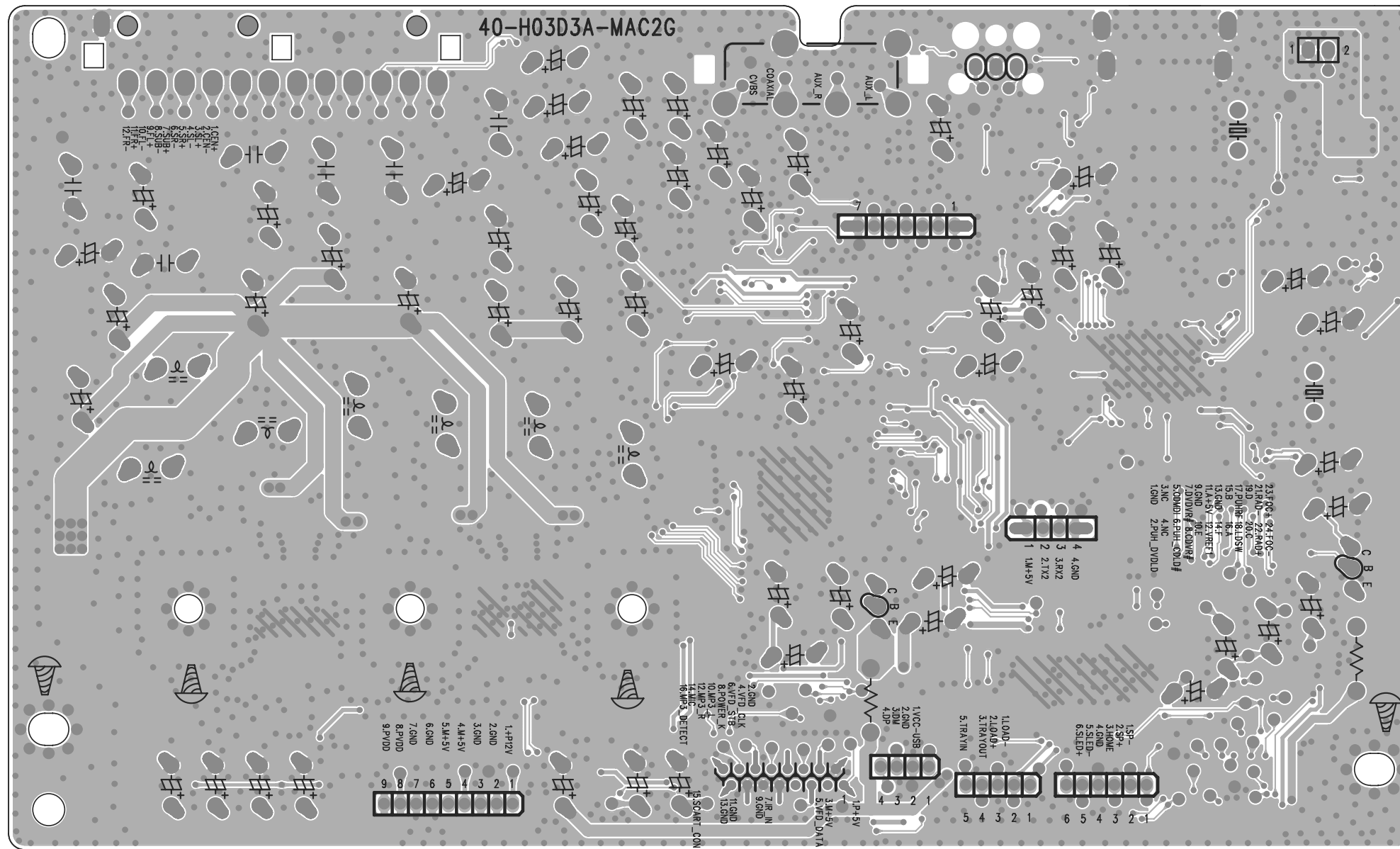

Voltages for per connect pin

XS751 from main board to power board

Pin No.	Pin Assign	Remark
1,2,3,6,7	GND	GND
4,5	M_5V	5V
8,9	PVDD	34V

XP221 from main board to FB board

PIN NO.	PIN Assign	Remark
1	VCC-USB	5V
2	GND	GND
3	USB_DM	USB D-
4	USB_DP	USB D+

XP82 from main board to FB board

Pin No.	Pin Assign	Remark(Voltage on operation)
1	P+5V	5V
2,9,11,13,	GND	GND
3	M+5V	5V
4	VFD_CLK	SPI signal
5	VFD_DATA	SPI signal
6	VFD_STB	SPI signal
7	IR_IN	IR signal
8	POWER_K	Power ON/OFF Control signal
10	MP3_L	MP3 input
12	MP3_R	MP3 input
14	MIC	MIC input

XP135 from main board to Loader

Pin No.	Pin Assign	Remark
1	SP-	SP- signal
2	SP+	SP+ signal
3	HOME	HOME signal
4	GND	GND
5	SLED-	SLED- signal
6	SLED+	SLED+ signal

XP136(4-5) from main board to Loader

Pin No.	Pin Assign	Remark
4	GND	GND
5	TRAYIN	TRAYIN signal

XP100 from main board to Loader

Pin No.	Pin Assign	Remark
1,9,13	GND	GND
2	PUH_DVDLD	PUH_DVDLD signal
3,4	NC	/
5	CDMDI	CDMDI signal
6	PUSH_CDLD	PUSH_CDLD signal
7	DVDVR	DVDVR signal
8	CDVR	CDVR signal
10	E	E signal
11	A+5V	5V
12	VREF1	VREF1 signal
14	F	F signal
15	B	B signal
16	A	A signal
17	PUHRF	PUHRF signal
18	LDSW	LDSW signal
19	D	D signal
20	C	C signal
21	RAD-	RAD- signal
22	RAD+	RAD+ signal
23	FOC+	FOC+ signal
24	FOC-	FOC- signal

Block Diagram for main IC SPHE8203R

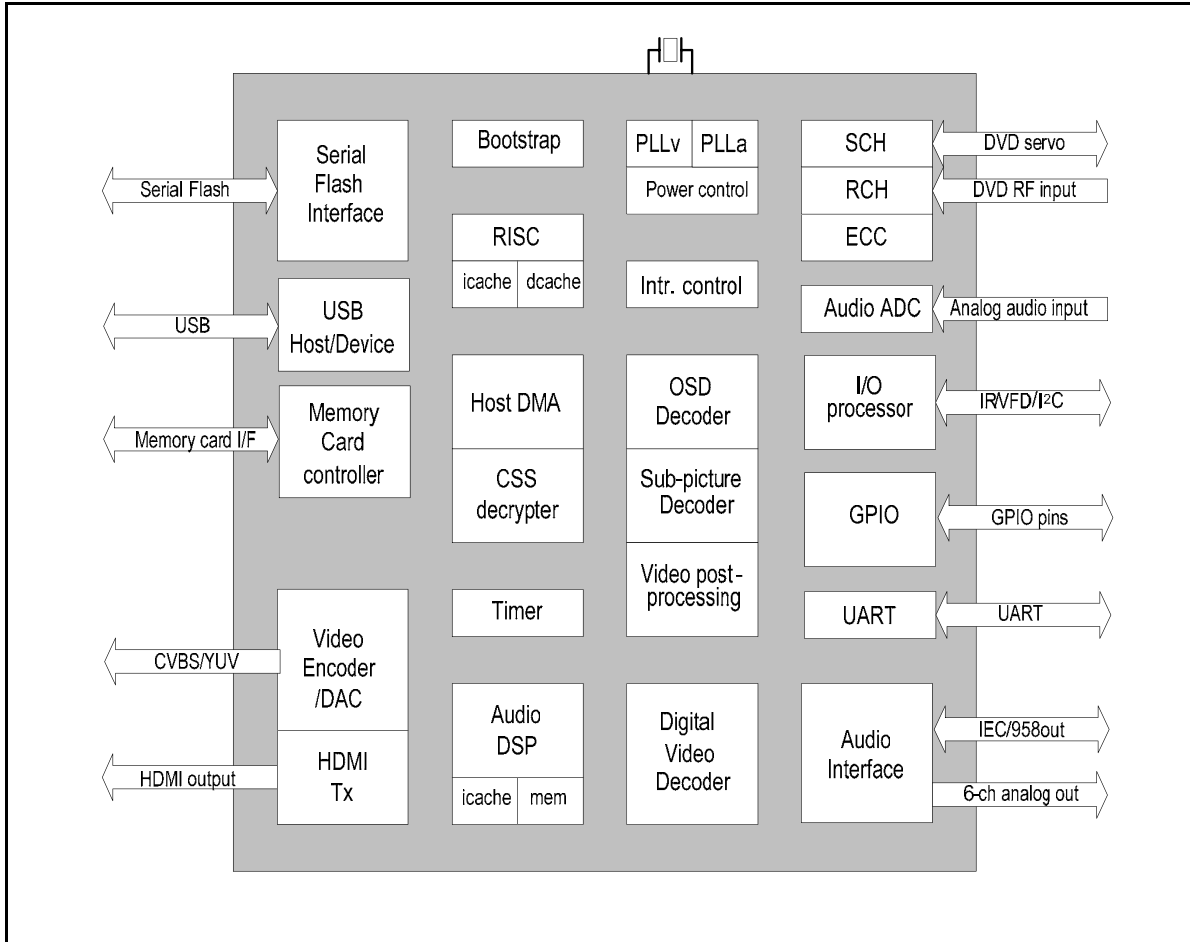

Pin Description

No.	Pin Name	Pin Type	Description
1	SPDC_OUT	I/O	Servo SPDC OUT
2	SC_OUT	I/O	Servo SC OUT
3	DMEA	I/O	Servo DMEA
4	DVDVR/GPIO/STEP_OUT	I/O	Servo STEP OUT
5	CDVR/GPIO/SC1_OUT	I/O	Servo SC1 OUT
6	TRAY_OUT/GPIO/DFCT	I/O	Servo TRAY OUT
7	TRAYIN/GPIO/FGIN	I/O	Servo TRAYIN or I2C CLK or GPIO[9]
8	TRAY+/GPIO/TRAYOUT	I/O	Servo TRAYOUT or GPIO[10]
9	SCART_SIG / GPIO	I/O	SCART_SIG / GPIO[11]
10	SCART_REL / GPIO	I/O	SCART_REL / GPIO[12]
11	SCART_DIS / GPIO	I/O	SCART_DIS / GPIO[13]
12	SPI_CSB	I/O	SPI chip select or GPIO[14]
13	SPI_D0	I/O	SPI data bit 0 or GPIO[15]
14	SPI_CLK	I/O	SPI clock or GPIO[16]
15	SPI_D1	I/O	SPI data bit 1 or GPIO[17]
16	IR/GPIO18	I/O	IR or GPIO[18]
17	VFD_CLK/GPIO19	I/O	GPIO[19] for VFD CLK
18	VFD_STB/GPIO20	I/O	GPIO[20] for VFD STB
19	VFD_DATA/GPIO21	I/O	GPIO[21] for VFD DATA
20	VDD12	S	Kernel logic power supply pins for chip kernel logic and input pre-driver #0
21	VDD_33	S	I/O power supply pins #0
22	RESET_B	I	System Reset
23	VSS	S	Chip kernel logic and output shared ground pin #0
24	HSYNC(1)/RX(1)/GPIO	I/O	GPIO [22] [IO]
25	VSYNC(1)/TX(1)/GPIO	I/O	GPIO [23] [IO]
26	SD_CLK/MS_CLK/GPIO	I/O	GPIO [24] [IO]
27	SD_CMD/MS_BS/GPIO	I/O	GPIO [25] [IO]
28	SD_D0/MS_D0/GPIO	I/O	GPIO [26] [IO]
29	SD_D1/MS_D1/GPIO	I/O	GPIO [27] [IO]
30	SD_D2/MS_D2/GPIO	I/O	GPIO [28] [IO]
31	SD_D3/MS_D3/GPIO	I/O	GPIO [29] [IO]
32	CARD_SENSE1/GPIO	I/O	GPIO [30] [IO]
33	CARD_RST/GPIO	I/O	GPIO [31] [IO]
34	GAME_D1/I2S_D2	I/O	GPIO [32] [IO]
35	GAME_D0/I2S_D1	I/O	GPIO [33] [IO]
36	GAEM_LATCH/I2S_D0	I/O	GPIO [34] [IO]
37	GAME_CLK/HSYNC(2)/RX(2)	I/O	GPIO [35] [IO]
38	VDD33	S	I/O power supply pins #1
39	VSS	S	Chip kernel logic and output shared ground pin #1
40	GPIO/VSYNC(2)/TX(2)	I/O	GPIO [47] [IO]
41	GPIO/I2S_DATA_IN	I/O	GPIO [48] [IO]
42	GPIO/I2S_LRCLK	I/O	GPIO [49] [IO]
43	GPIO/I2S_BCLK	I/O	GPIO [50] [IO]
44	GPIO/I2S_XCLK	I/O	GPIO [51] [IO]

No.	Pin Name	Pin Type	Description
45	HDMI_HPD/GPIO	I/O	GPIO [52] [IO]
46	HDMI_CEC/GPIO	I/O	GPIO [53] [IO]
47	DDC_SDA	I/O	GPIO [54] [IO]
48	DDC_SCL	I/O	GPIO [55] [IO]
49	AUDIO_MUTE/GPIO	I/O	GPIO [56] [IO]
50	SPDIF_IN	I/O	GPIO [57] [IO]
51	SPDIF_OUT	I/O	GPIO [58] [IO]
52	VDD12	S	Kernel logic power supply pins for chip kernel logic and input pre-driver #1
53	VDD_33	S	I/O power supply pins #2
54	V_COMP	A	Video DAC Bias Voltage
55	V_FSADJ	A	Full-Scale adjust control pin (EXT resistor) (1.2 K ohm to ground)
56	TV_DAC0	A	Video DAC channel 0 output
57	TV_AVDD	S	3.3V power for Video DAC channel 0
58	TV_AVSS	S	Ground pin for Video DAC channel 0
59	TV_AVDD	S	3.3V power for Video DAC channel 1~3
60	TV_DAC1	A	Video DAC channel 1 output
61	TV_DAC2	A	Video DAC channel 2 output
62	TV_DAC3	A	Video DAC channel 3 output
63	TV_AVSS	S	Ground pin for Video DAC channel 1~3
64	AD_AVDD	S	3.3V power for Audio ADC
65	AIN	A	ADC analog input
66	AD_AVSS	S	Ground for Audio ADC
67	AOUT_RS	A	DAC RS channel analog output
68	AOUT_LS	A	DAC LS channel analog output
69	ADAC_AVSS	S	Ground pin for Audio DAC
70	AOUT_RN	A	DAC RN channel analog output
71	AOUT_LN	A	DAC LN channel analog output
72	VREF	A	Reference voltage for Audio DAC
73	ADAC_AVDD	S	3.3V power for Audio DAC
74	ADAC_AVDD	S	3.3V power for Audio DAC
75	ADAC_AVSS	S	Ground pin for Audio DAC
76	AOUT_R	A	DAC right channel analog output
77	AOUT_L	A	DAC left channel analog output
78	EXT_SWING	A	HDMI EXT SWING
79	HAPGND0	S	Ground pin for HDMI PHY
80	TXC-	A	HDMI TXC-
81	TXC+	A	HDMI TXC+
82	HAVCC	S	1.25V power for HDMI PHY
83	TX0-	A	HDMI TX0-
84	TX0+	A	HDMI TX0+
85	HAPGND	S	Ground pin for HDMI PHY
86	TX1-	A	HDMI TX1-
87	TX1+	A	HDMI TX1+
88	HAVCC	S	1.25V power for HDMI PHY
89	TX2-	A	HDMI TX2-

No.	Pin Name	Pin Type	Description
90	TX2+	A	HDMI TX2+
91	HAPGND	S	Ground pin for HDMI PHY
92	AD_AVDD	S	3.3V power for ADC
93	HOME/GPIO	I/O	servo test out 0 or GPIO[96] (HOME)
94	LDSW/GPIO	I/O	servo test out 1 or GPIO[97] (LDSW)
95	AD_AVSS	S	ADC ground pin
96	RF_AVDD	S	3.3V power for RF
97	AGCCAP	A	External AGC capacitor connected to ground. (0.1u)
98	RFIS	I	Single-ended RF equalizer input.
99	DVDC	I	DVD RF inputs, from the main beam photo detector.
100	DVDD	I	DVD RF inputs, from the main beam photo detector.
101	DVDA	I	DVD RF inputs, from the main beam photo detector.
102	DVDB	I	DVD RF inputs, from the main beam photo detector.
103	CDF	I	CD tracking error inputs, from the sub-beam photo detector.
104	CDE	I	CD tracking error inputs, from the sub-beam photo detector.
105	OPVIP	I	Op-amp 1 positive input.
106	OPVIN	I	Op-amp 1 negative input.
107	RF_APC_AVSS	S	Ground pin for RF and APC
108	CDMDI	I	CD APC input from monitor photo diode.
109	DVDMDI	I	DVD APC input from monitor photo diode.
110	CDLDO	O	CD APC output.
111	DVDLDO	O	DVD APC output.
112	SRV_AVDD	S	3.3V power for SERVO
113	V21	A	Reference DC bias voltage.
114	DA_AVSS	S	3.3V GND for SERVO
115	PLL_VSS	S	Ground pin for PLLH, PLLTV, PLLA, and Crystal PAD
116	PLL_VDD	S	3.3V power for PLLH, PLLTV, PLLA, and Crystal PAD
117	CILKN	I	Crystal PAD input
118	CLKOUT	O	Crystal PAD output
119	USB_AVSS	S	Ground pin for USB PLL and USB transceiver
120	USB_DM	A	USB bus D-
121	USB_DP	A	USB bus D+
122	USB_AVDD	S	3.3V power for USB PLL and USB transceiver
123	VDD_33	S	I/O power supply pins #3
124	VDD_12	S	Kernel logic power supply pins for chip kernel logic and input pre-driver #2
125	VDDQ	S	2.5V Power for OTP programming
126	V165	I/O	Servo PDM VREF
127	DA_TEO	I/O	Servo PDM DA TEO
128	DA_FEO	I/O	Servo PDM DA FEO

Note: Please refer to SPHE8203R servo datasheet for servo related information.

Exploded View for HTD3570/12:

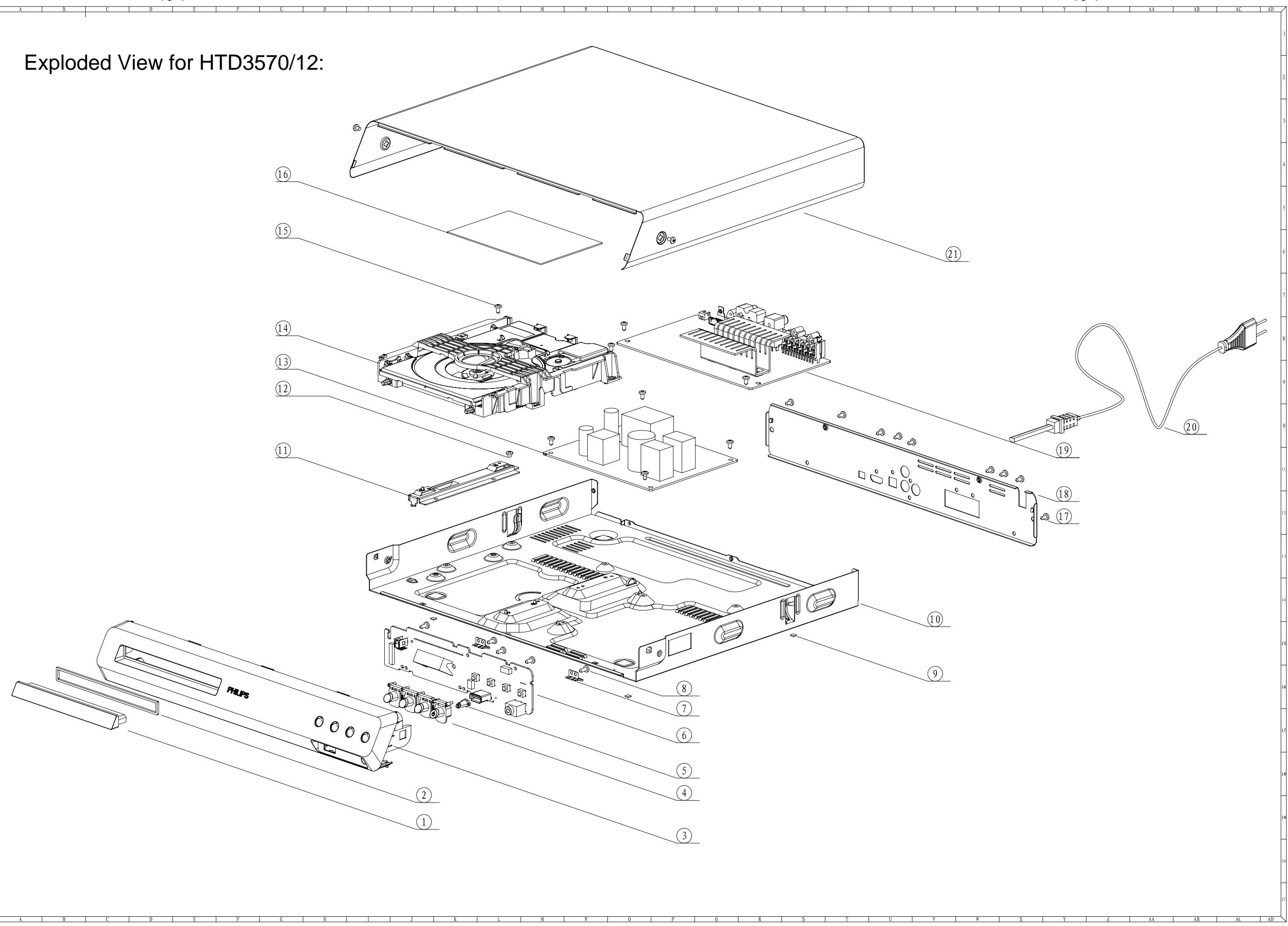

Exploded View for HTD3570/98:

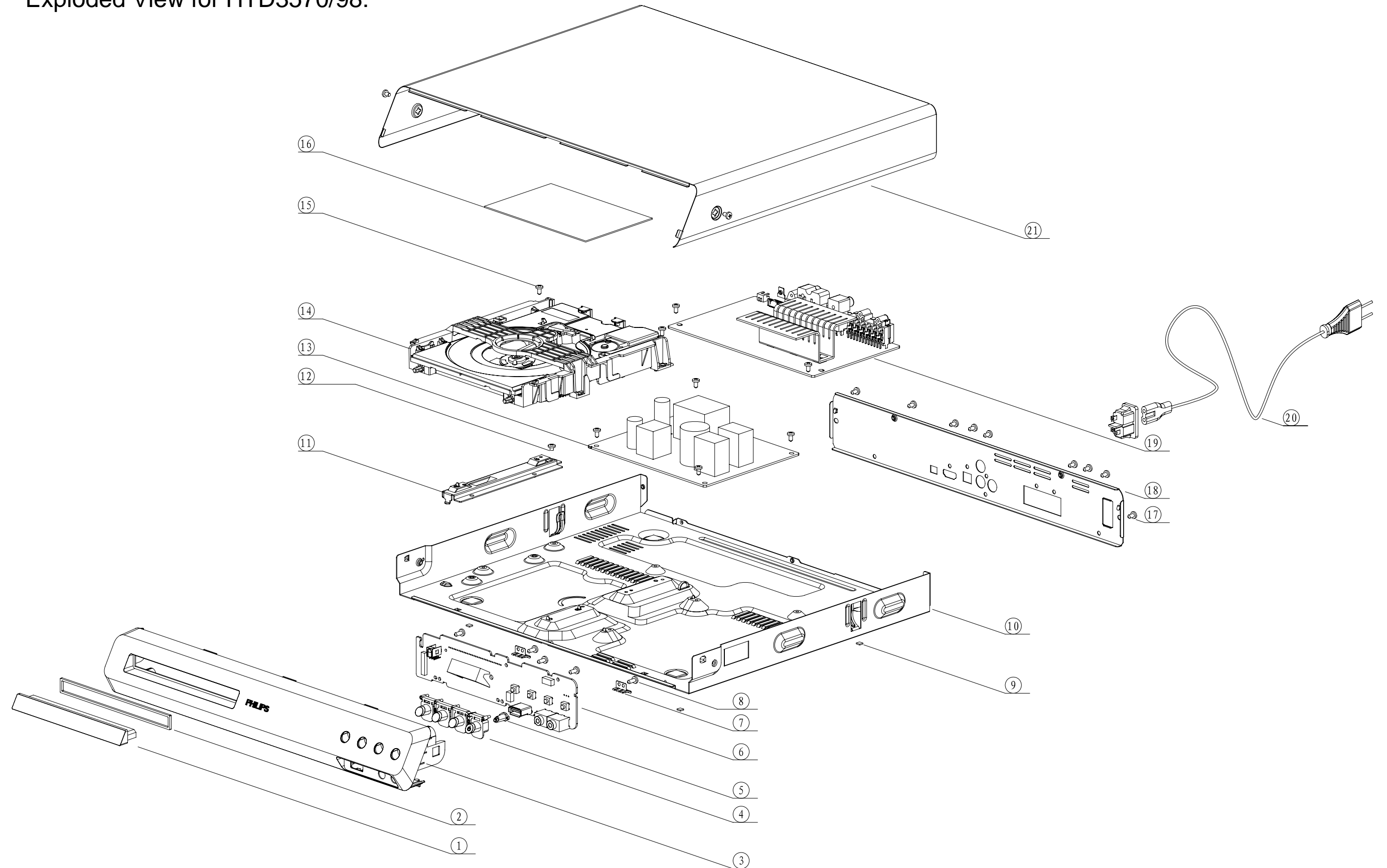

Exploded View for HTD3570/51:

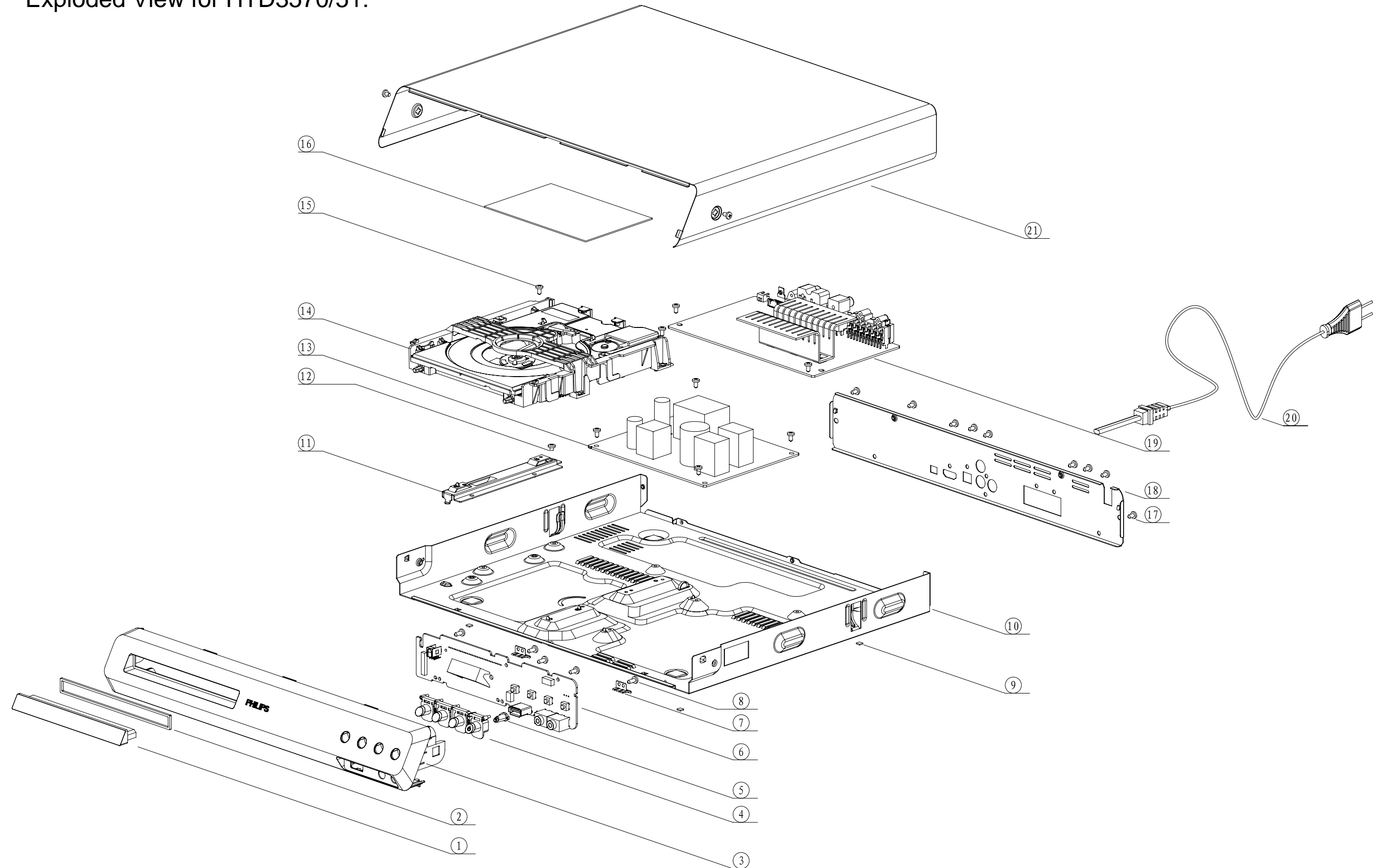

Revision List

Version 1.0

* Initial Release for HTD3570/12.

Version 1.1

* Initial Release for HTD3570/98/51.