

# I. OTHERS

<b>BLOCK DIAGRAMS .....</b>	<b>I-2</b>
<b>OVERALL .....</b>	<b>I-2</b>
<b>CIRCUIT DIAGRAMS .....</b>	<b>I-3</b>
<b>OVERALL .....</b>	<b>I-3</b>
<b>MC-PCA (ALL) .....</b>	<b>I-4</b>
<b>MC-PCA (ASIC) .....</b>	<b>I-5</b>
<b>MC-PCA (SDRAM) .....</b>	<b>I-6</b>
<b>MC-PCA (FLASH MEMORY) .....</b>	<b>I-7</b>
<b>MC-PCA (XD) .....</b>	<b>I-8</b>
<b>MC-PCA (USB) .....</b>	<b>I-9</b>
<b>MC-PCA (TFT) .....</b>	<b>I-10</b>
<b>MC-PCA (VIDEO) .....</b>	<b>I-11</b>
<b>MC-PCA (CCD) .....</b>	<b>I-12</b>
<b>MC-PCA (Audio) .....</b>	<b>I-13</b>
<b>MC-PCA (LENS) .....</b>	<b>I-14</b>
<b>MC-PCA (SW DIODE) .....</b>	<b>I-15</b>
<b>PW-PCA (POWER ALL) .....</b>	<b>I-16</b>
<b>PW-PCA (POWER) .....</b>	<b>I-17</b>
<b>SW FPCA .....</b>	<b>I-18</b>
<b>CCD FPCA .....</b>	<b>I-19</b>
<b>FL PCA .....</b>	<b>I-20</b>
<b>LD FPCA .....</b>	<b>I-21</b>
<b>Z FPCA .....</b>	<b>I-22</b>
<b>MOUNTING DIAGRAMS .....</b>	<b>I-23</b>
<b>MC-PCA .....</b>	<b>I-23</b>
<b>PW-PCA .....</b>	<b>I-24</b>
<b>SW-FPCA .....</b>	<b>I-25</b>
<b>CCD-FPCA .....</b>	<b>I-26</b>
<b>FL-PCA .....</b>	<b>I-27</b>
<b>LD FPCA .....</b>	<b>I-28</b>
<b>Z FPCA .....</b>	<b>I-29</b>

# μ-30 / μ[mju:] 410 / Stylus410 DIGITAL BLOCK DIAGRAM : OVERALL

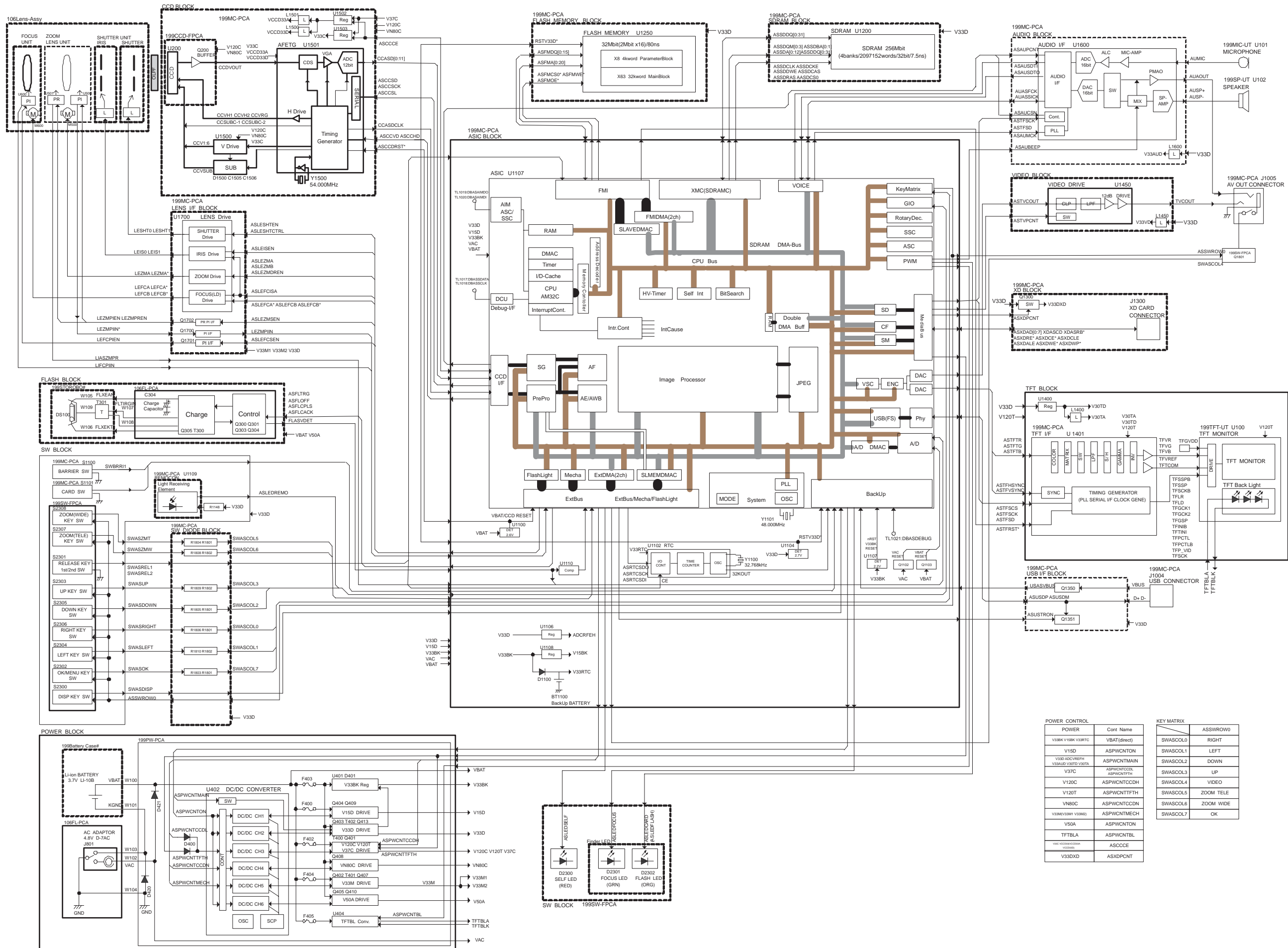

POWER	Cort Name	KEY MATRIX	ASSWROW0
V33B V15B V338K	V33RTC	SWASC00	RIGHT
V15D	ASPCWNTON	SWASC01	LEFT
V120C ADC/REFH V33AUD V330D V30TA	ASPCWNTMAIN	SWASC02	DOWN
V37C	ASPCWNTCCD	SWASC03	UP
V120C	ASPCWNTCCDH	SWASC04	VIDEO
V120T	ASPCWNTFTTH	SWASC05	ZOOM TELE
VN80C	ASPCWNTCCDN	SWASC06	ZOOM WIDE
V33M1 V33M2 V33M3	ASPCWNTMECH	SWASC07	OK
V50A	ASPCWNTON		
TFTBLA	ASPCWNTBL		
ASCCCE	ASCCCE		
V33DXD	ASXPCNT		

# μ-30 / μ[mju:] 410 / Stylus410 DIGITAL CIRCUIT DIAGRAM : OVER ALL

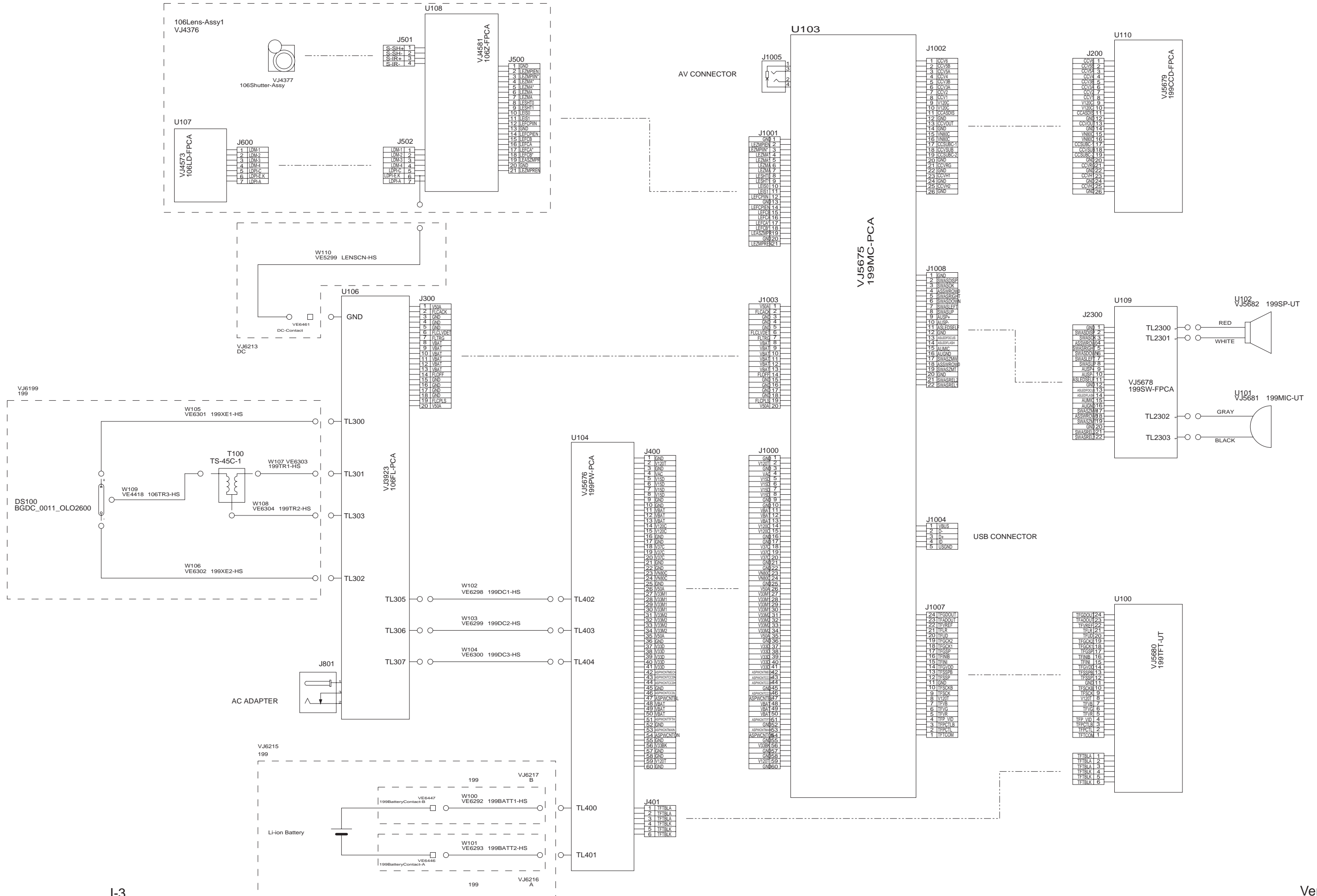

# μ-30 / μ[mju:] 410 / Stylus410 DIGITAL CIRCUIT DIAGRAM : MC-PCA (ALL)

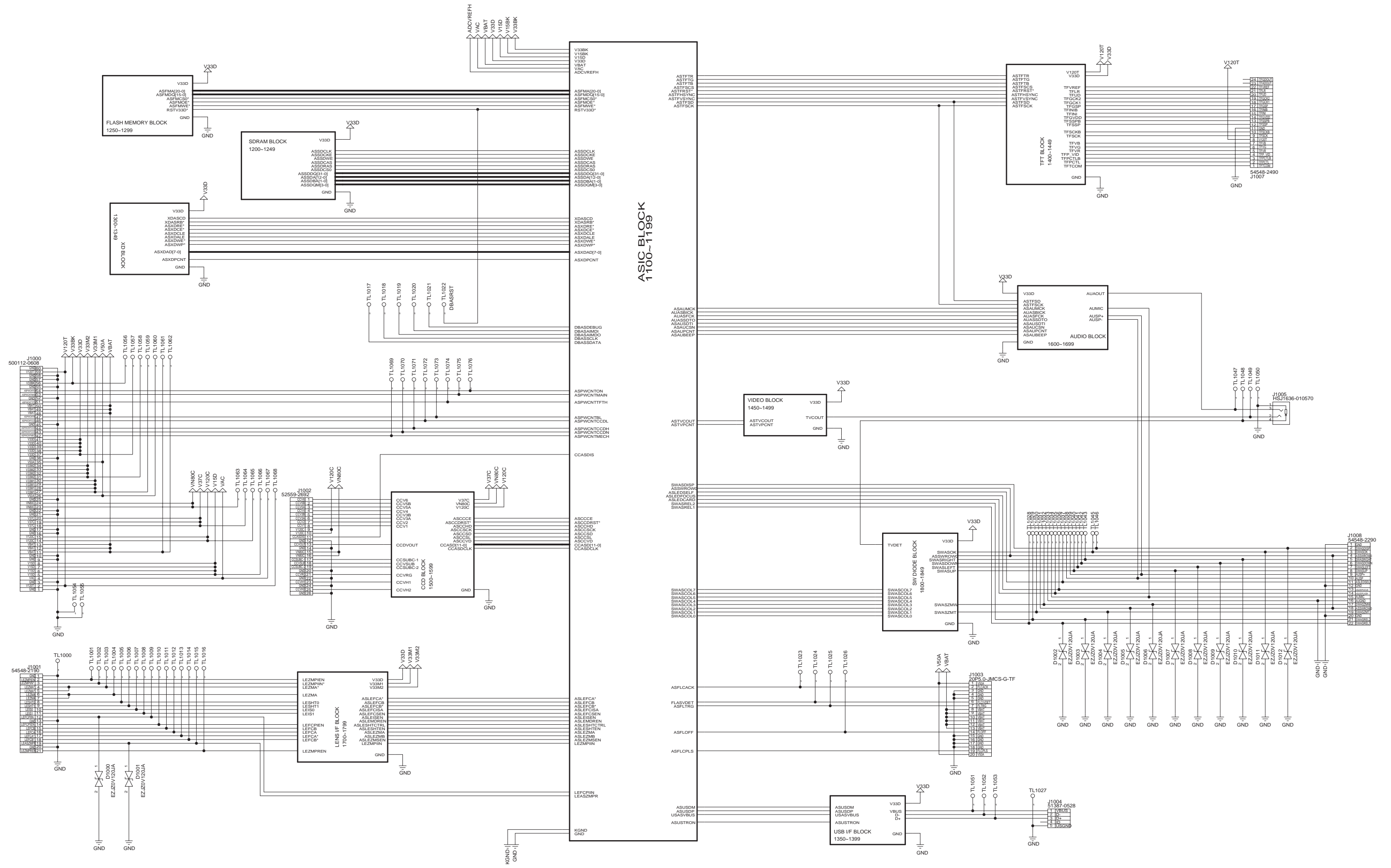

# μ-30 / μ[mju:] 410 / Stylus410 DIGITAL CIRCUIT DIAGRAM : MC-PCA (ASIC)

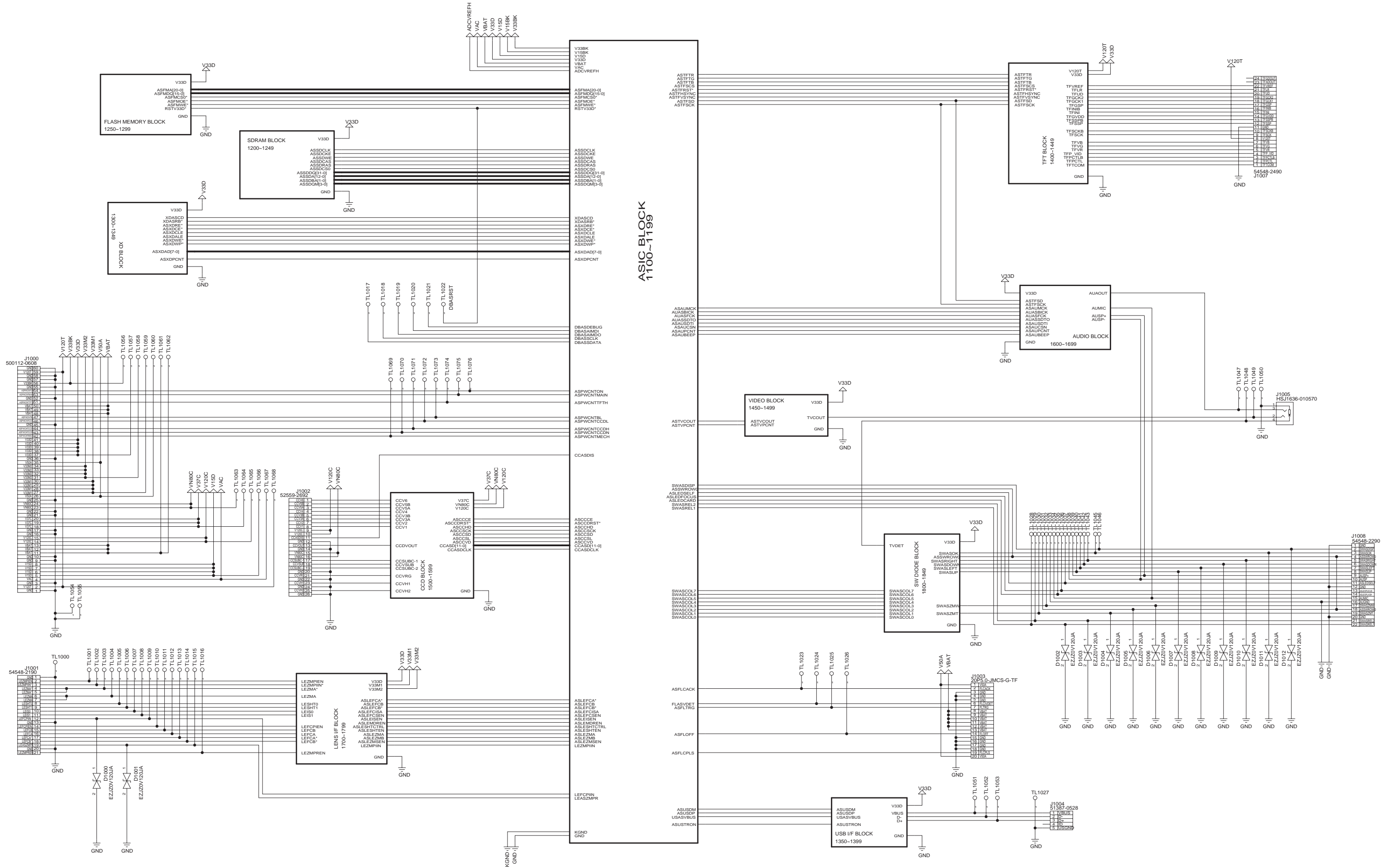

# μ-30 / μ[mju:] 410 / Stylus410 DIGITAL CIRCUIT DIAGRAM : MC-PCA (SDRAM)

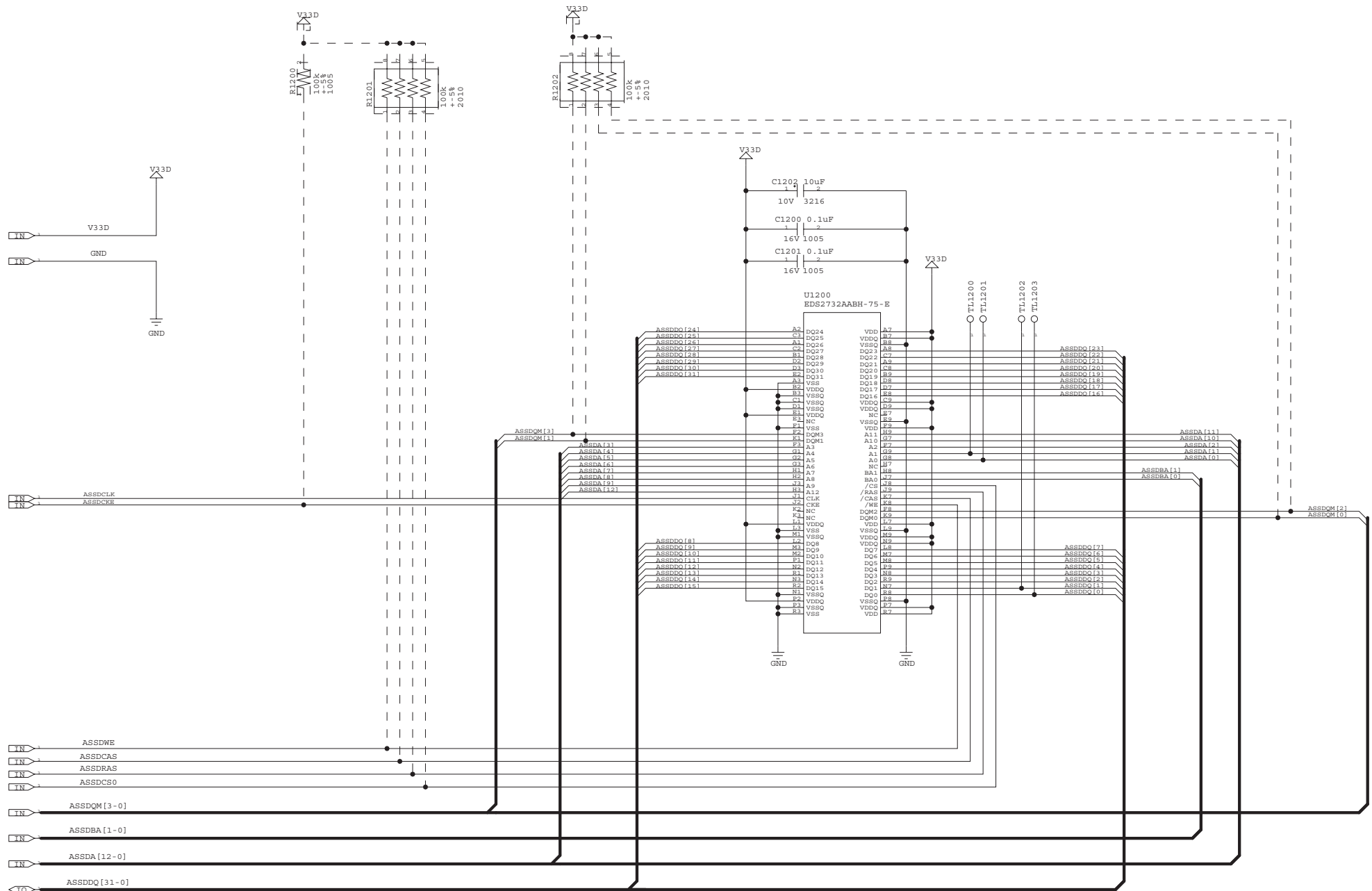

# μ-30 / μ[mju:] 410 / Stylus410 DIGITAL CIRCUIT DIAGRAM : MC-PCA (FLASHMEMORY)

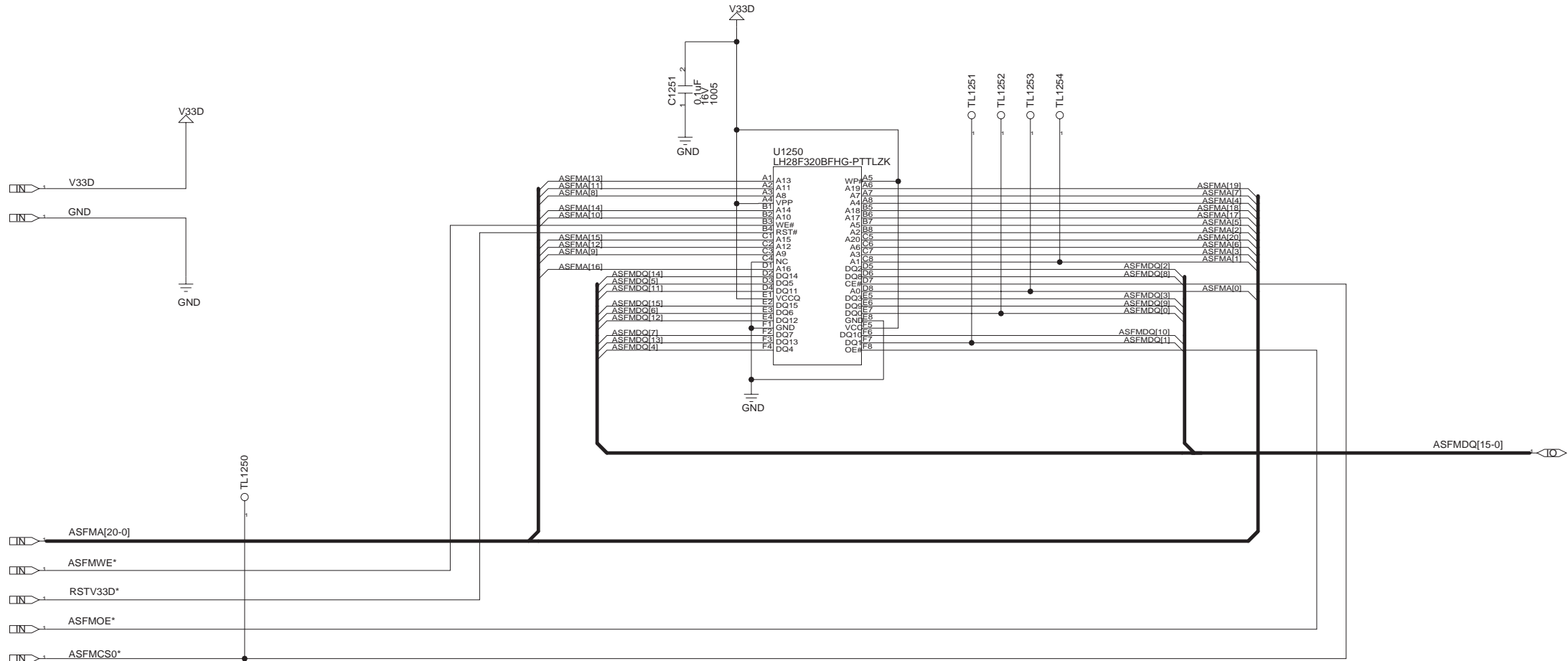

# μ-30 / μ[mju:] 410 / Stylus410 DIGITAL CIRCUIT DIAGRAM : MC-PCA (XD)

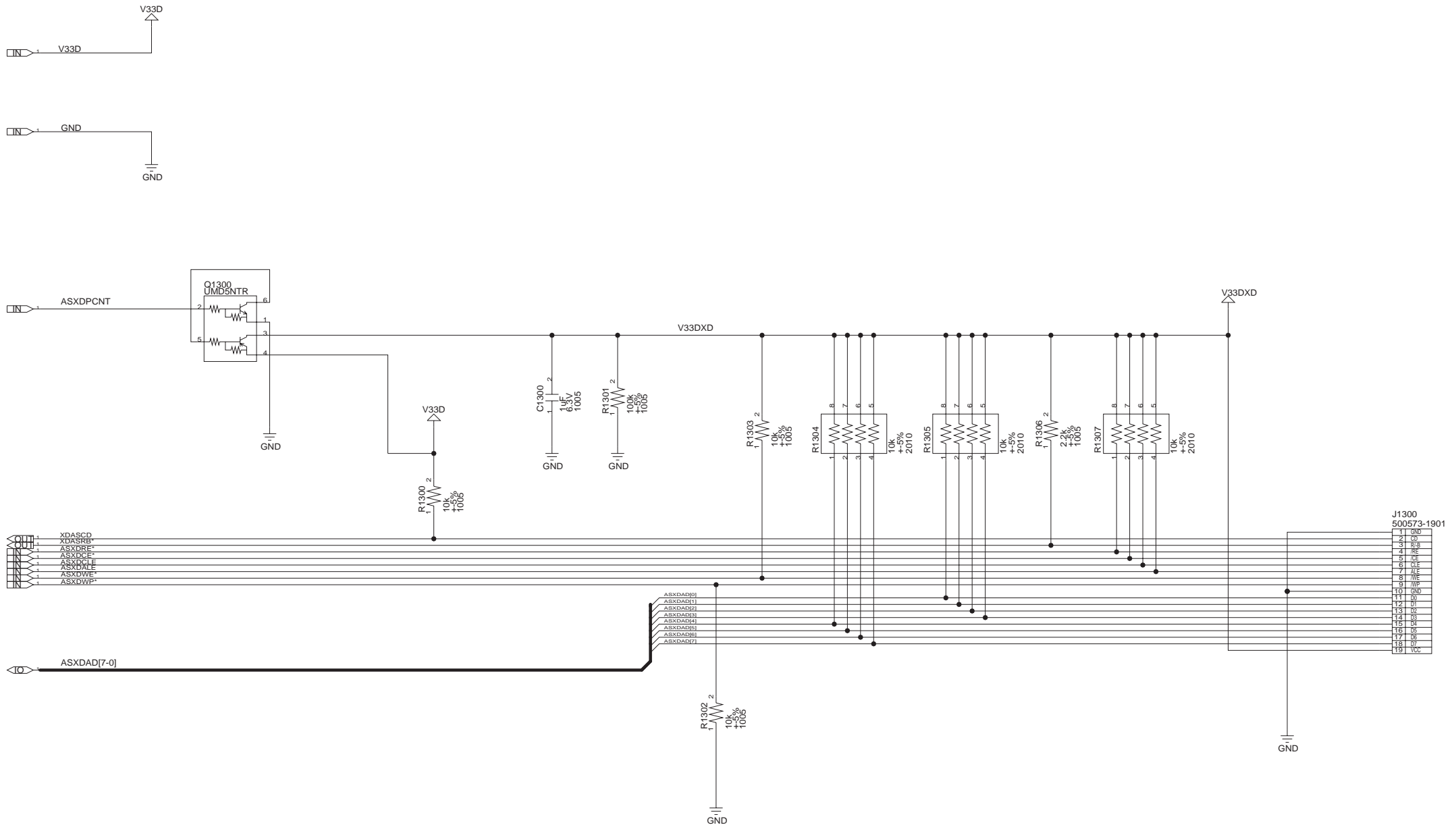



# μ-30 / μ[mju:] 410 / Stylus410 DIGITAL CIRCUIT DIAGRAM : MC-PCA (USB)

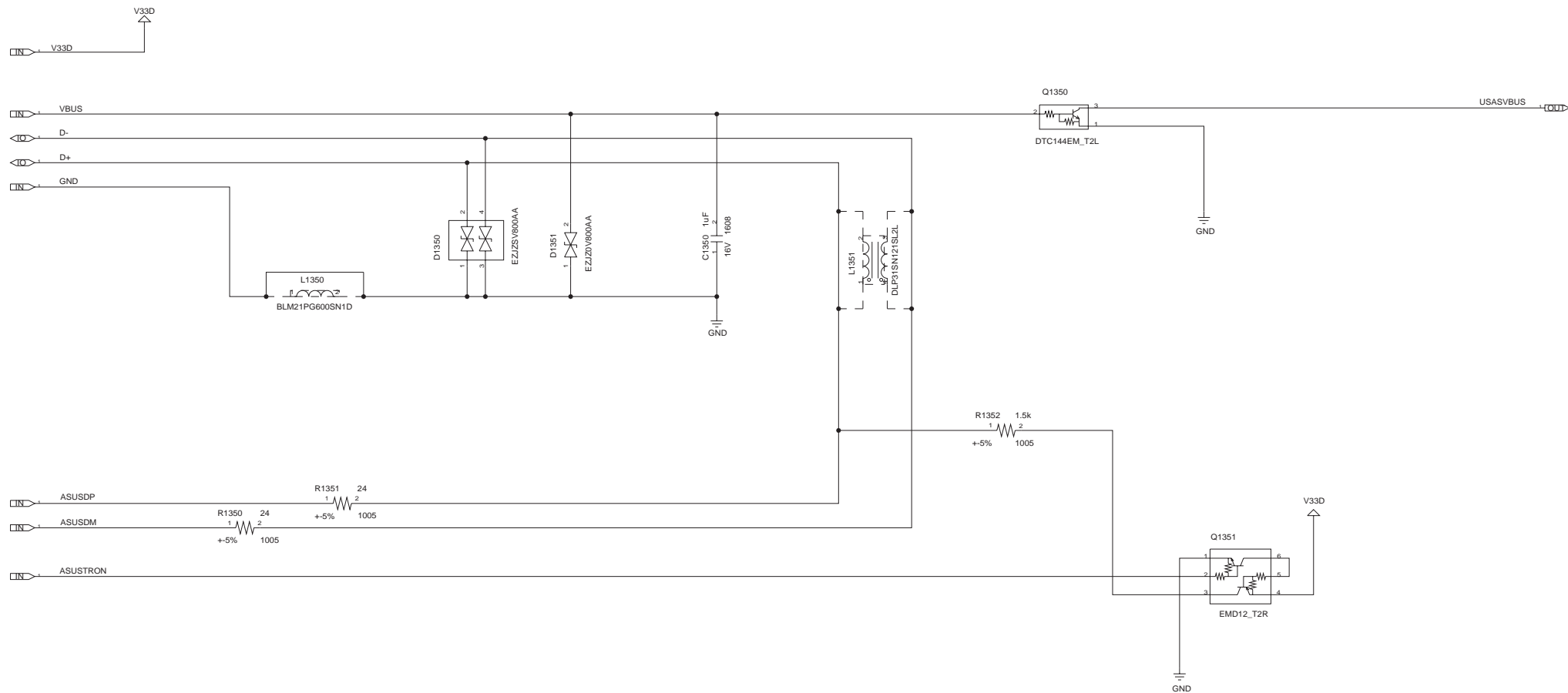

# μ-30 / μ[mju:] 410 / Stylus410 DIGITAL CIRCUIT DIAGRAM : MC-PCA (TFT)

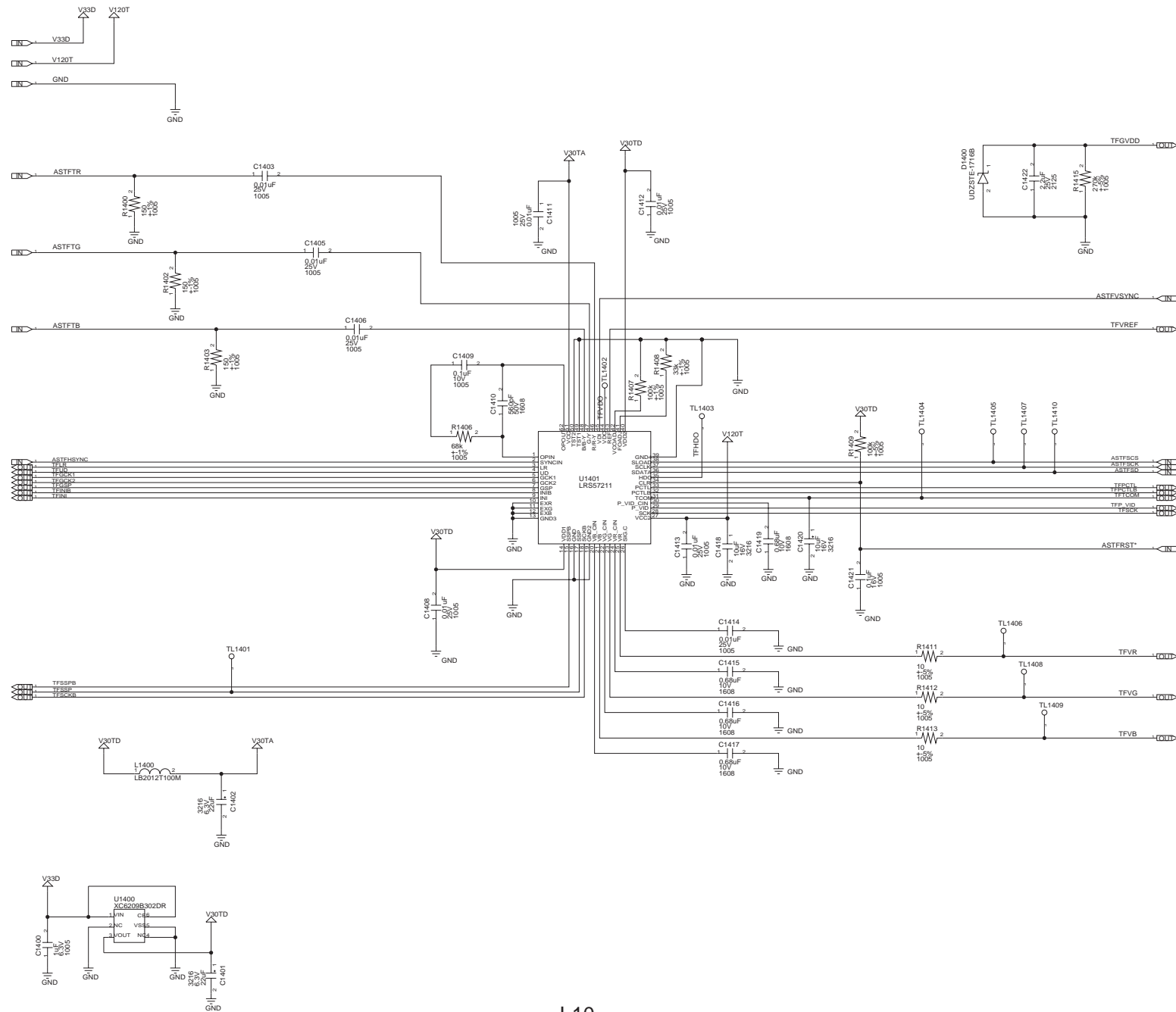

# μ-30 / μ[mju:] 410 / Stylus410 DIGITAL CIRCUIT DIAGRAM : MC-PCA (VIDEO)

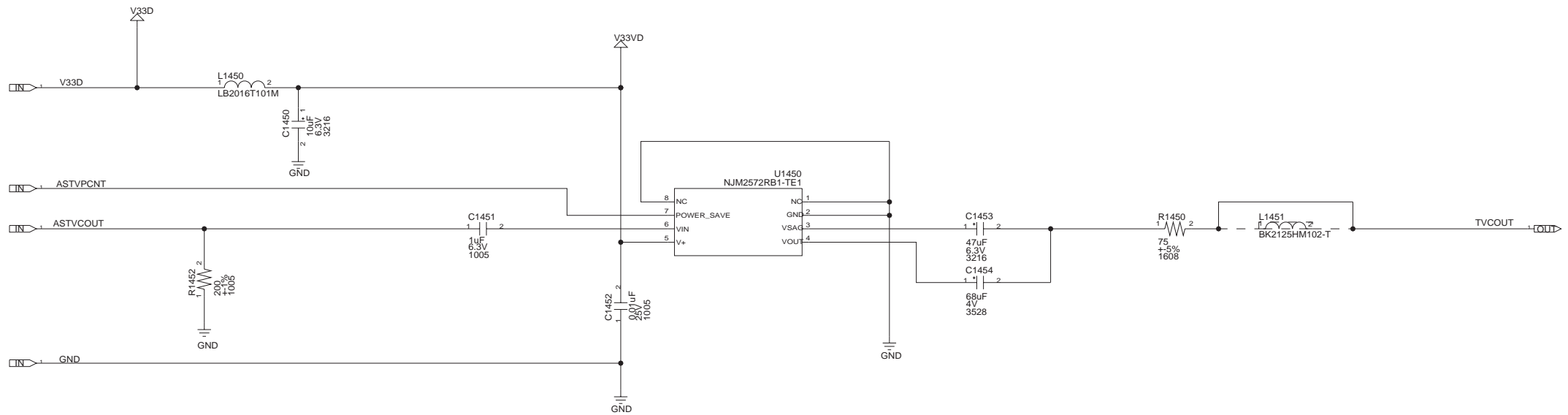

# μ-30 / μ[mju:] 410 / Stylus410 DIGITAL CIRCUIT DIAGRAM : MC-PCA (CCD)

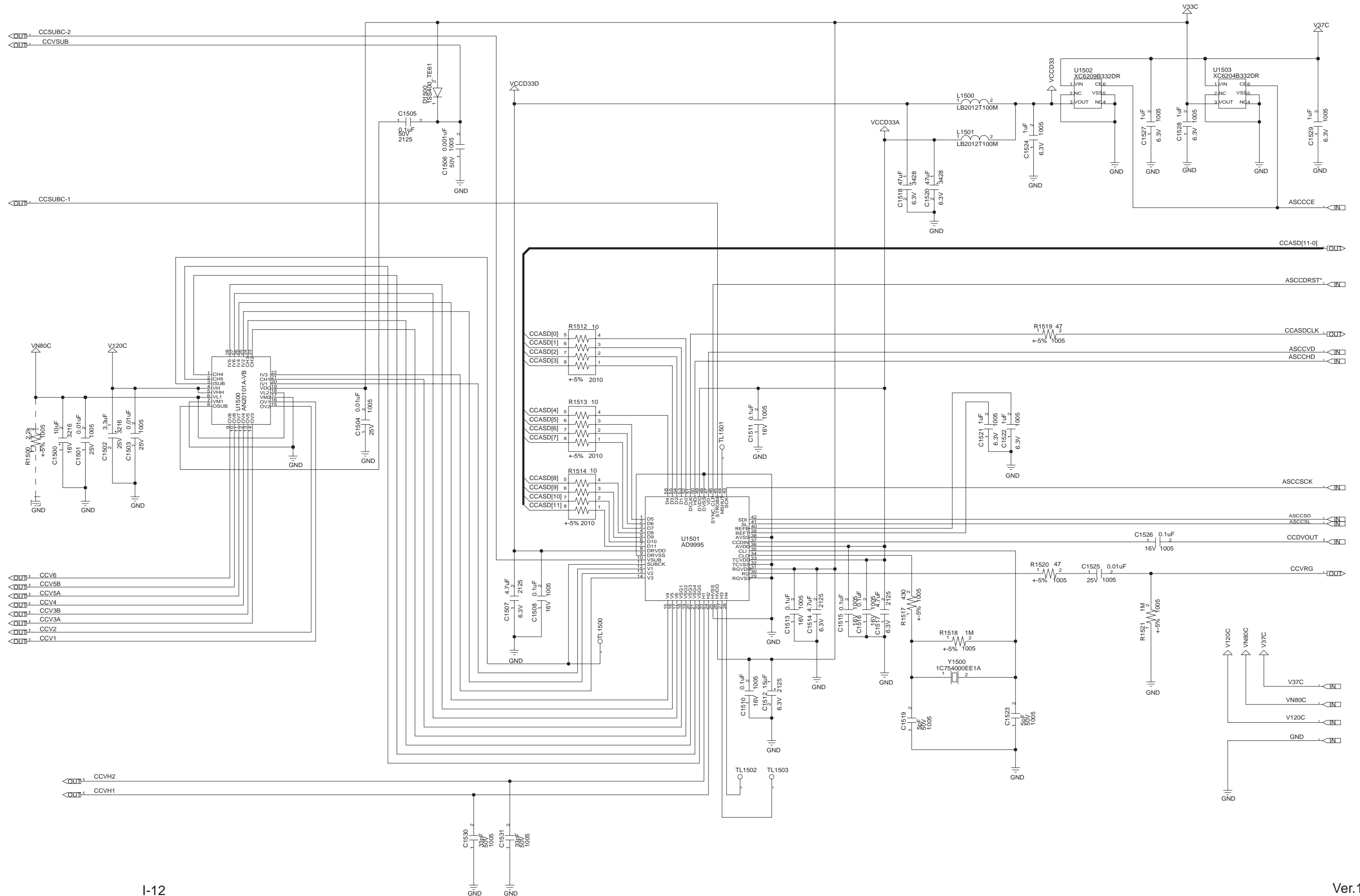

# μ-30 / μ[mju:] 410 / Stylus410 DIGITAL CIRCUIT DIAGRAM : MC-PCA (Audio)

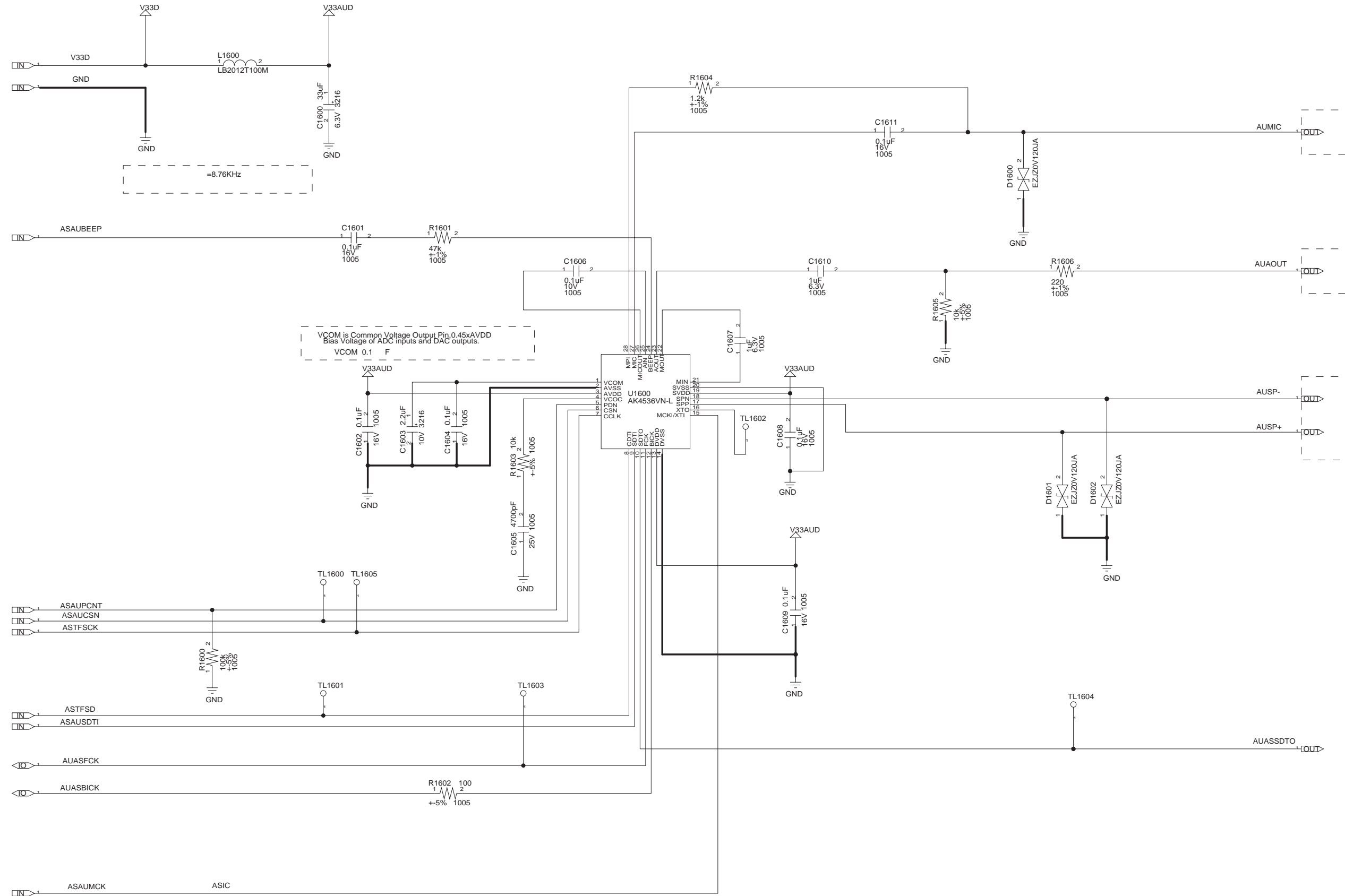

D4194 ET1					
R1605	2.2K	MIN-MOUT	C	F	
AUASFCK			TP		

# μ-30 / μ[mju:] 410 / Stylus410 DIGITAL CIRCUIT DIAGRAM : MC-PCA (LENS)

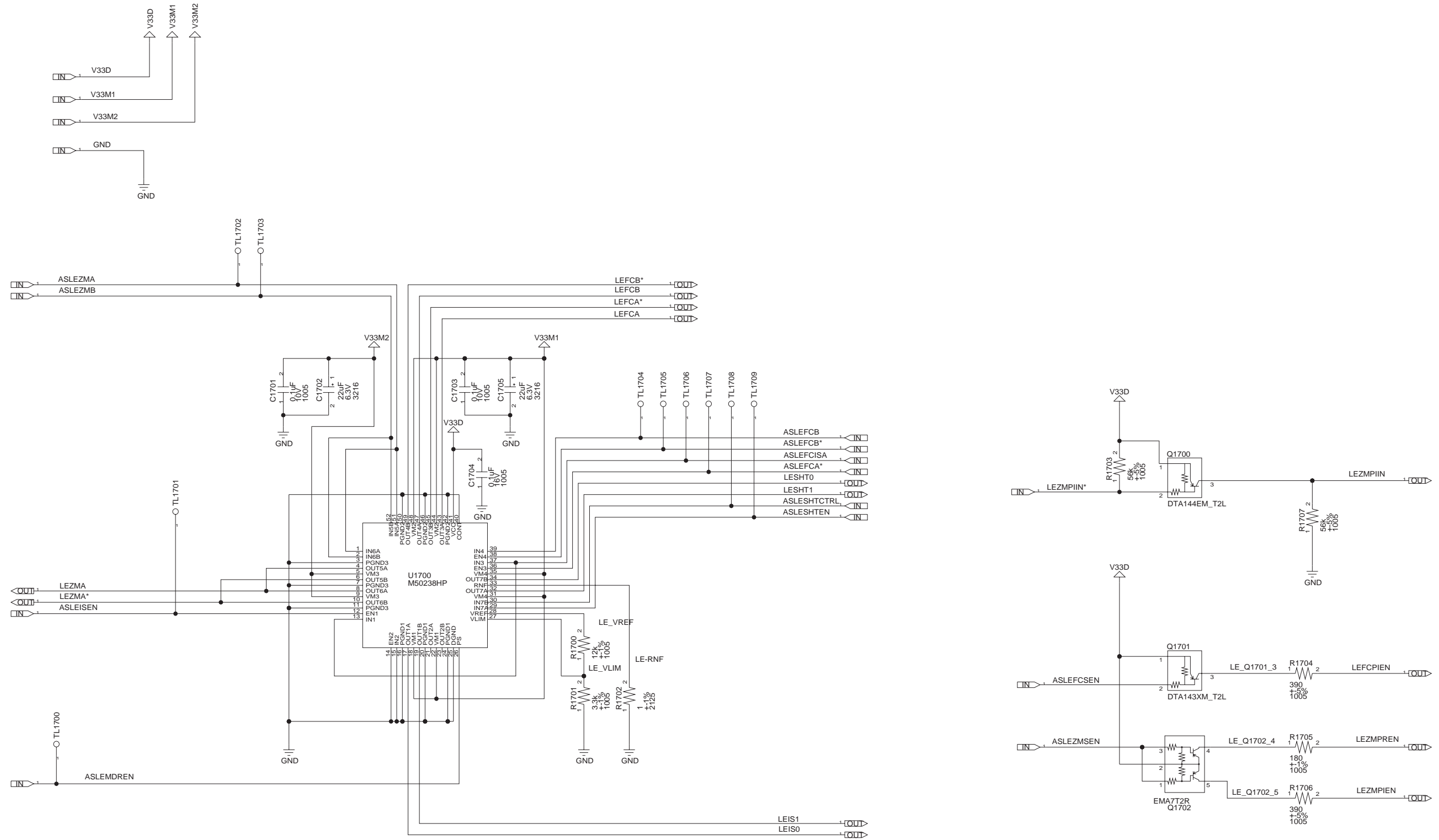

# μ-30 / μ[mju:] 410 / Stylus410 DIGITAL CIRCUIT DIAGRAM : MC-PCA (SW DIODE)

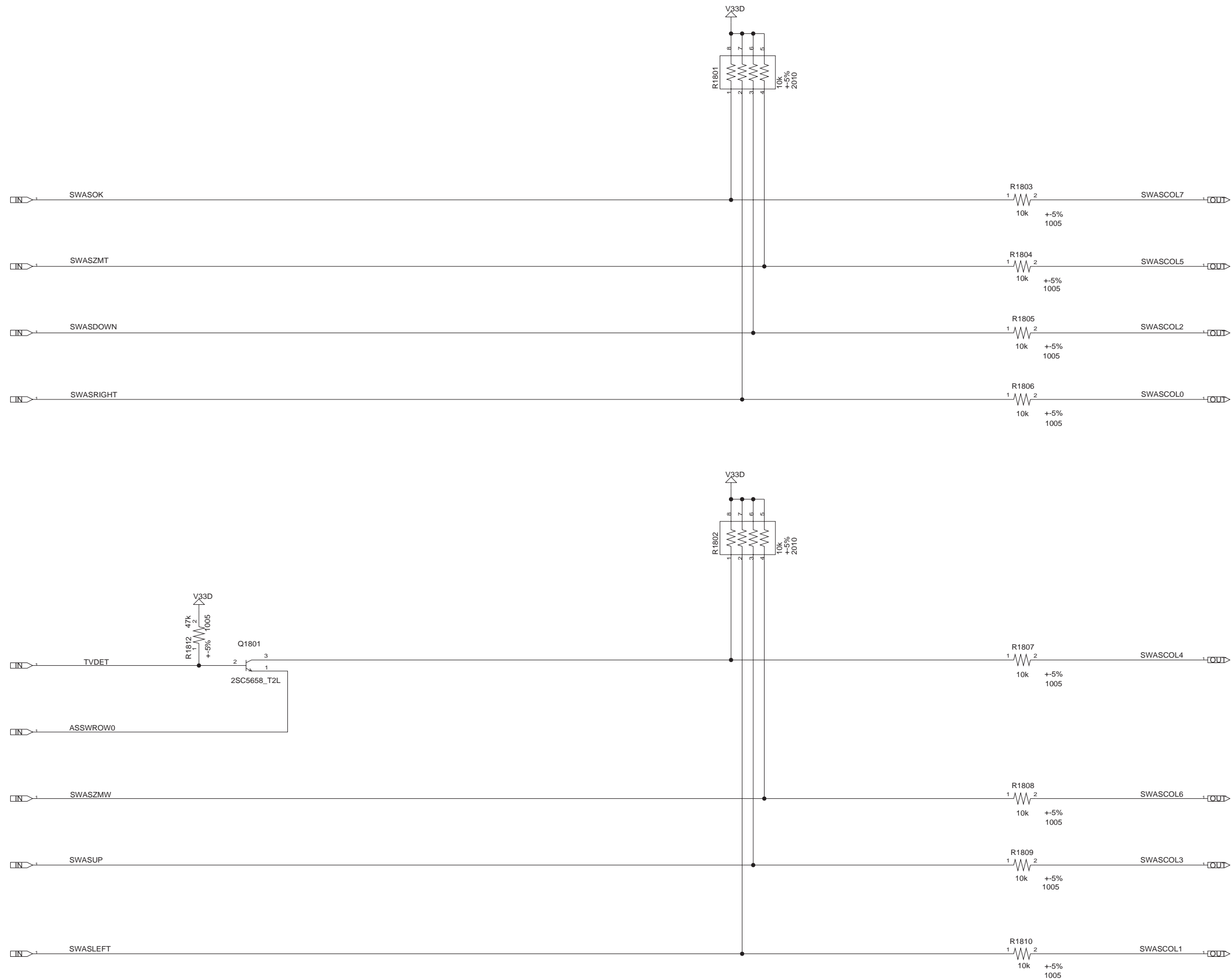
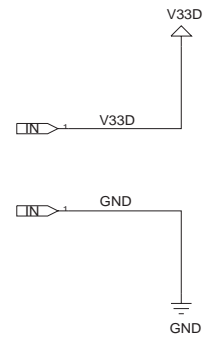

# μ-30 / μ[mju:] 410 / Stylus410 DIGITAL CIRCUIT DIAGRAM : PW-PCA (POWER ALL)

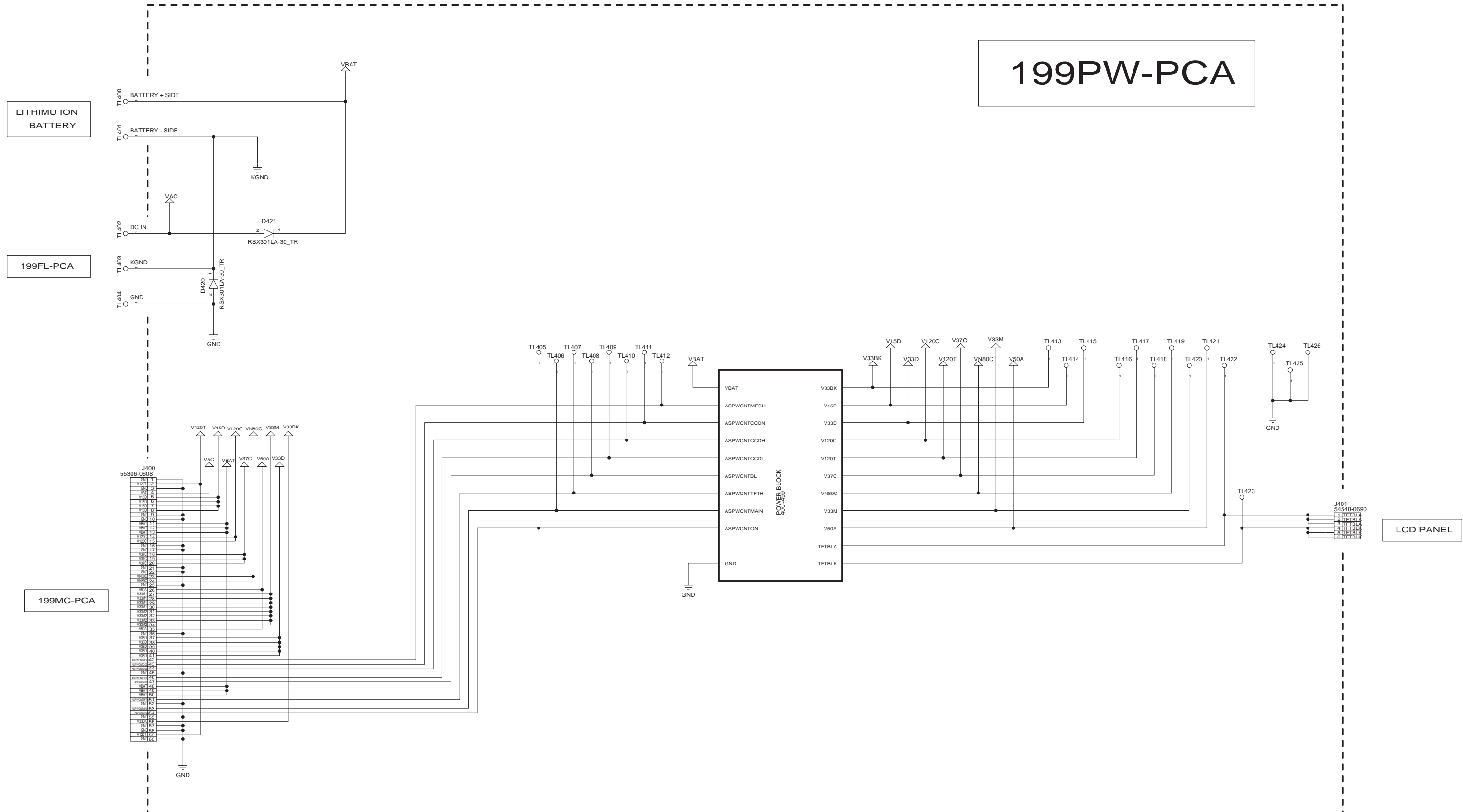



# μ-30 / μ[mju:] 410 / Stylus410 DIGITAL CIRCUIT DIAGRAM : PW-PCA (POWER)

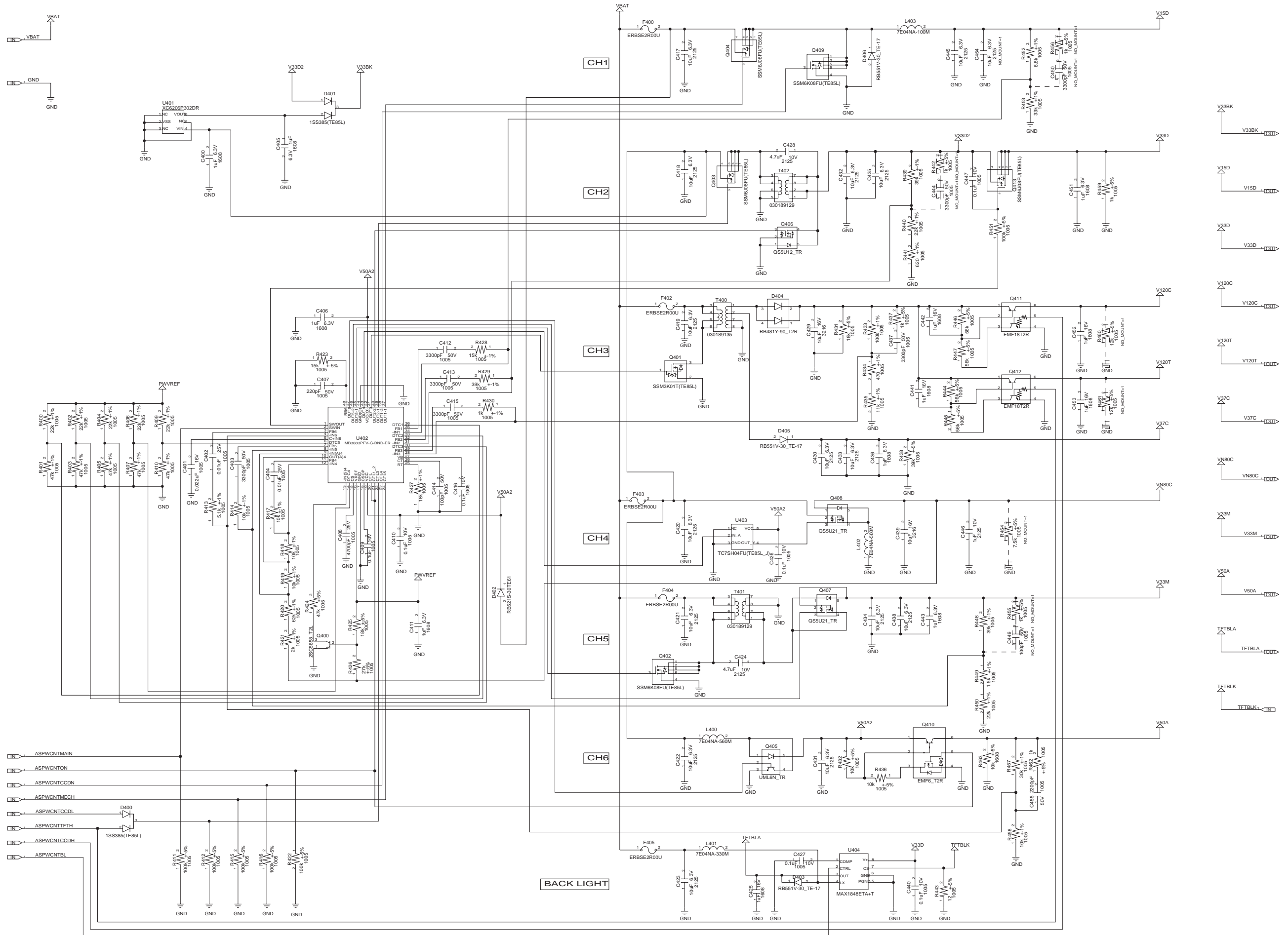

# μ-30 / μ[mju:] 410 / Stylus410 DIGITAL CIRCUIT DIAGRAM : SW FPCA

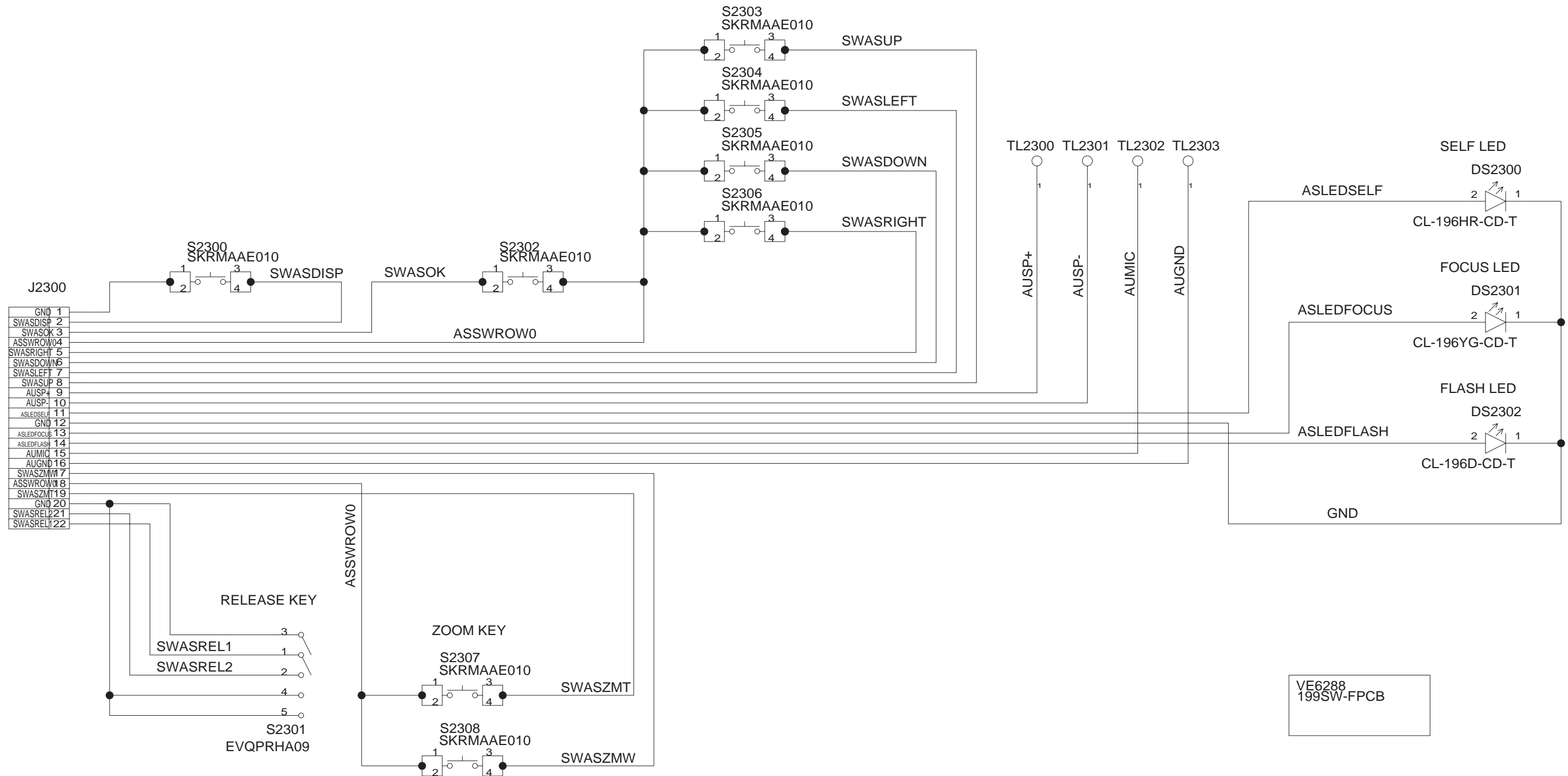

# μ-30 / μ[mju:] 410 / Stylus410 DIGITAL CIRCUIT DIAGRAM : CCD FPCA

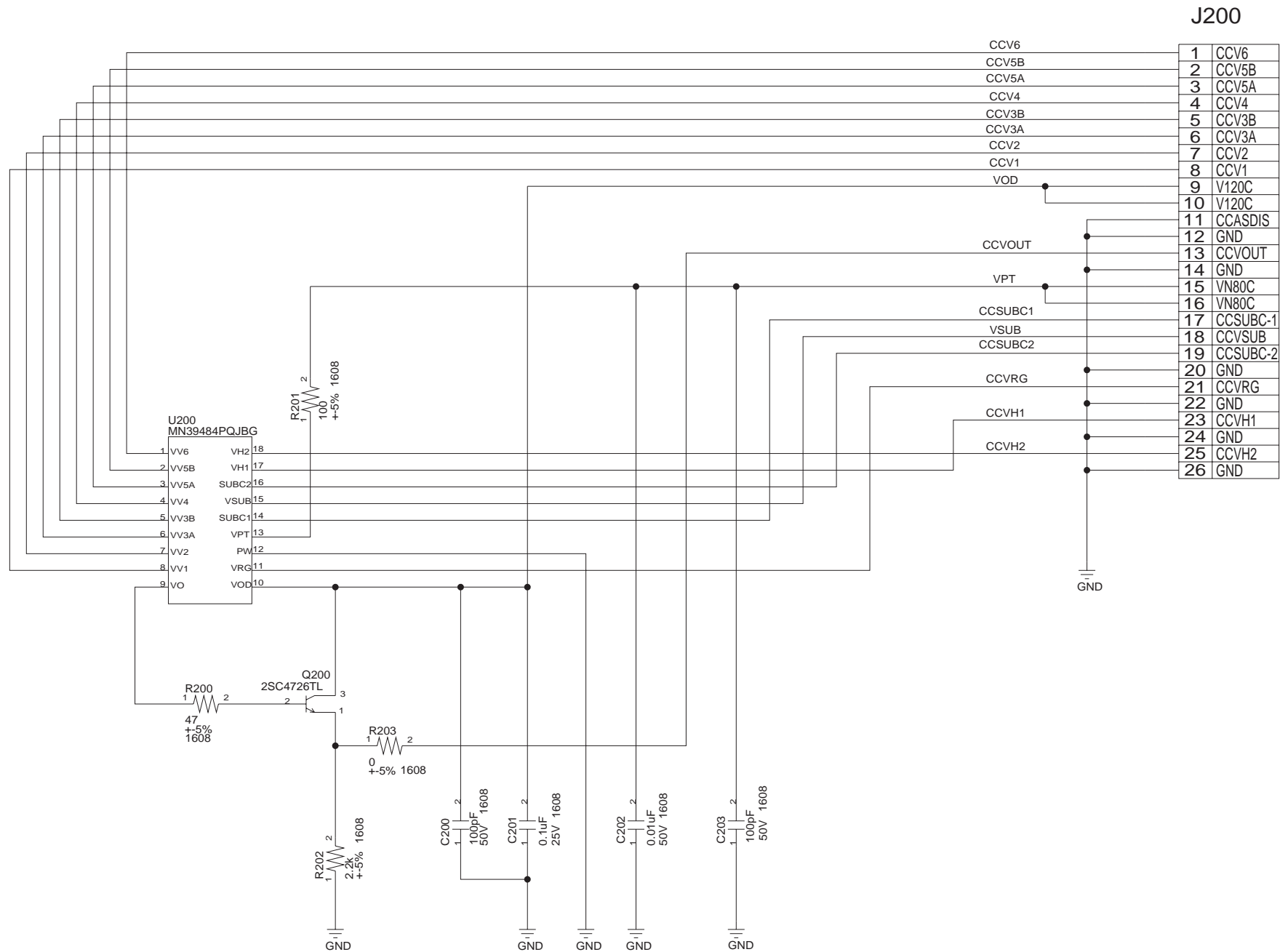

VE6289  
199CCD-FPCB

# μ-30 / μ[mju:] 410 / Stylus410 DIGITAL CIRCUIT DIAGRAM : FL PCA

FL\_BLOCK

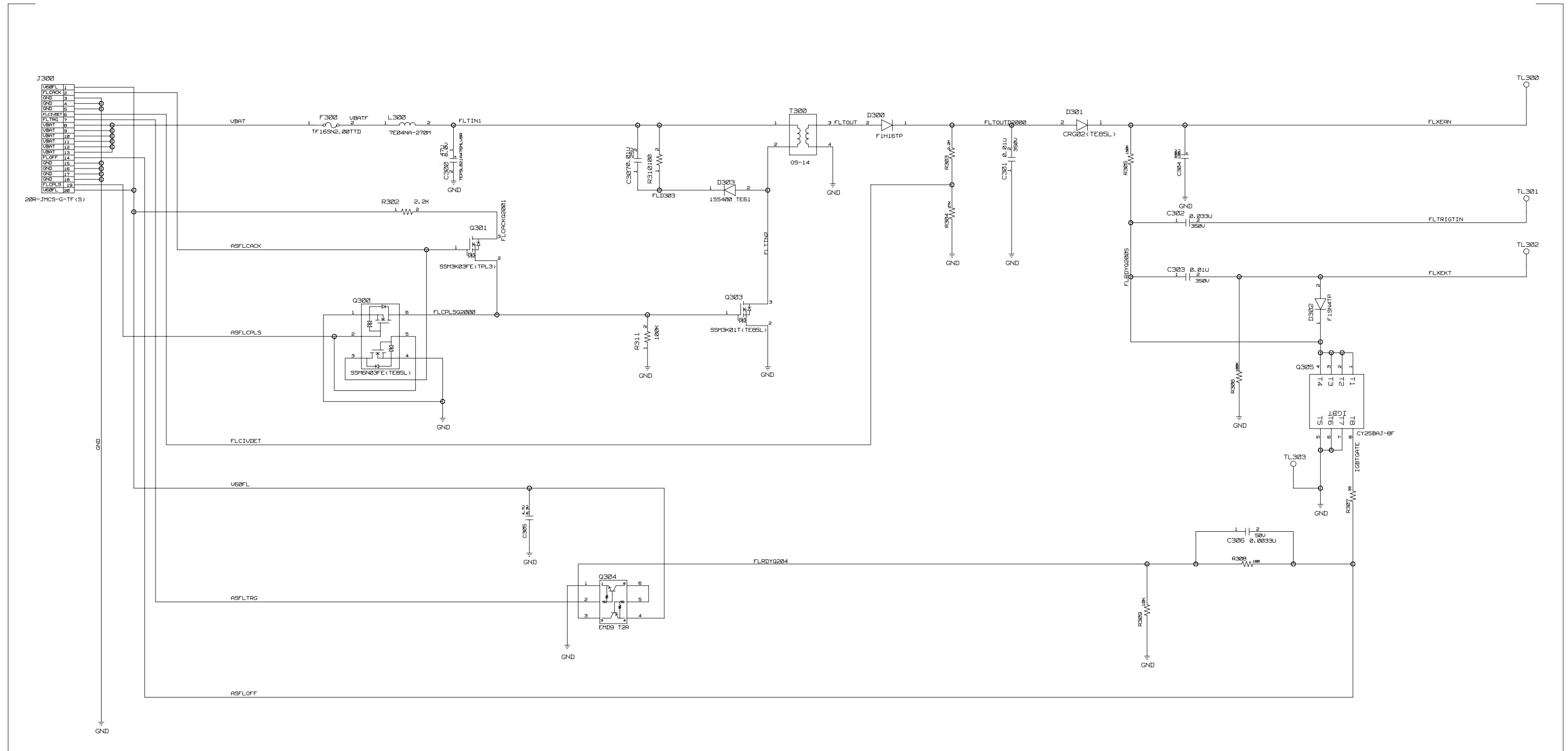

DC\_BLOCK

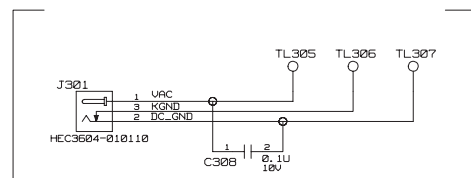

# μ-30 / μ[mju:] 410 / Stylus410 DIGITAL CIRCUIT DIAGRAM : LD FPCA

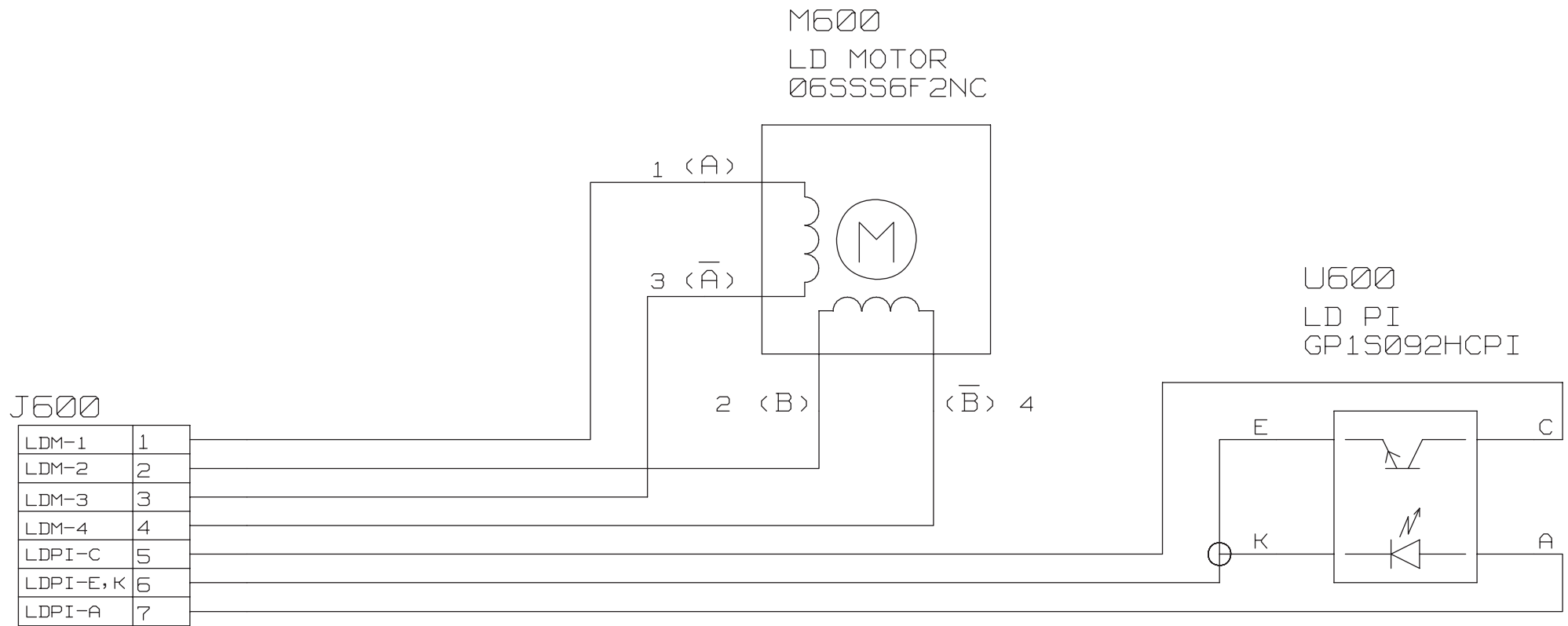

# μ-30 / μ[mju:] 410 / Stylus410 DIGITAL CIRCUIT DIAGRAM : Z FPCA

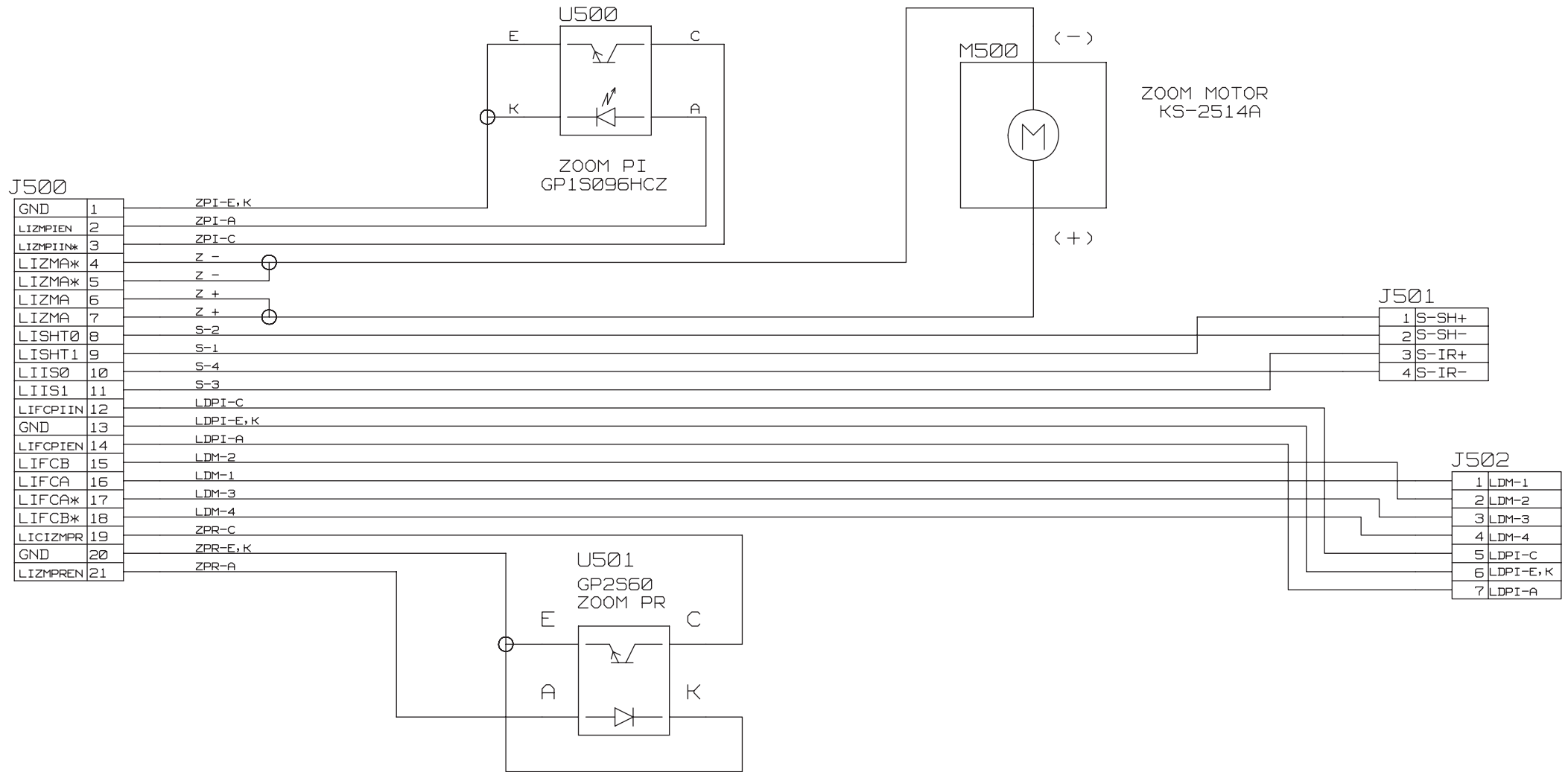

# μ-30 / μ[mju:] 410 / Stylus410 DIGITAL MOUNTING DIAGRAM : MC-PCA

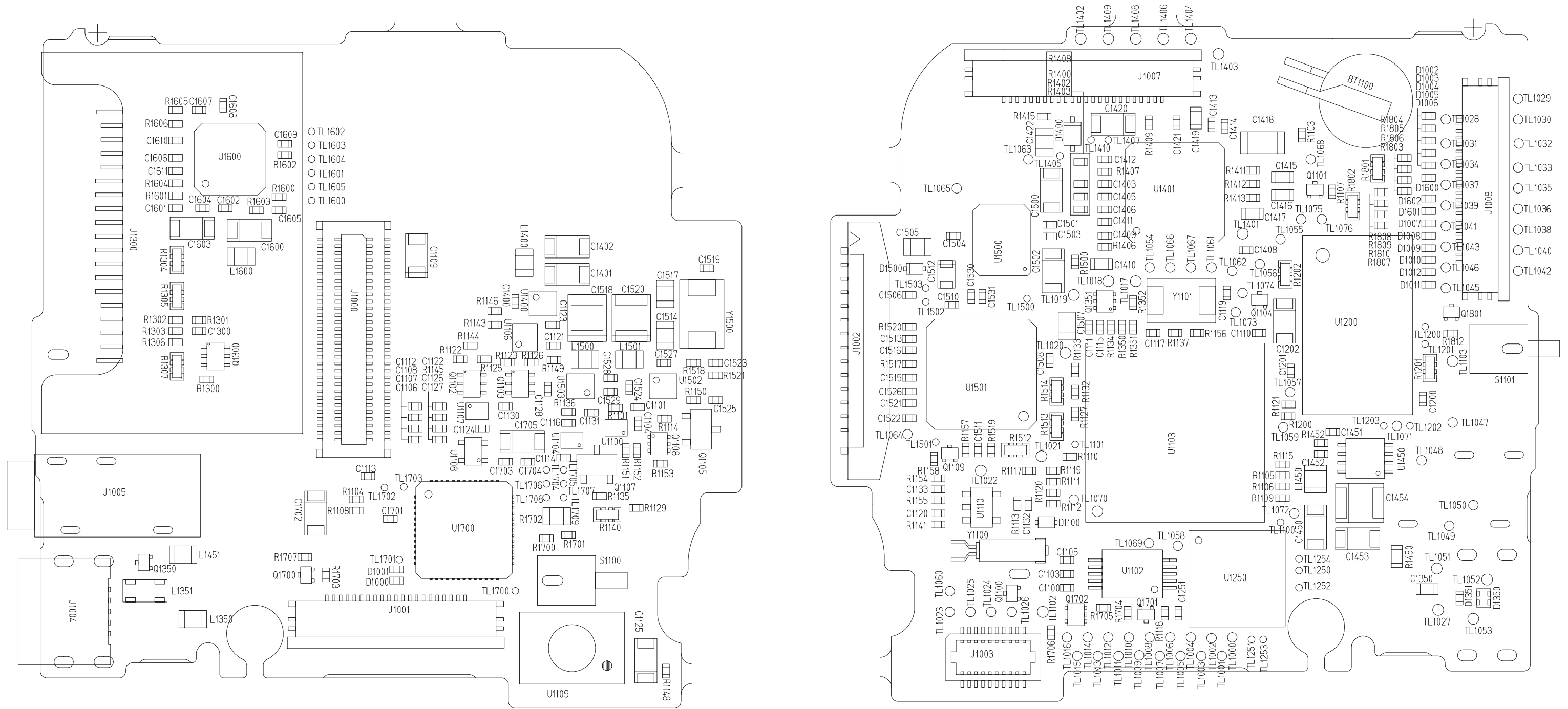

# μ-30 / μ[mju:] 410 / Stylus410 DIGITAL MOUNTING DIAGRAM : PW-PCA

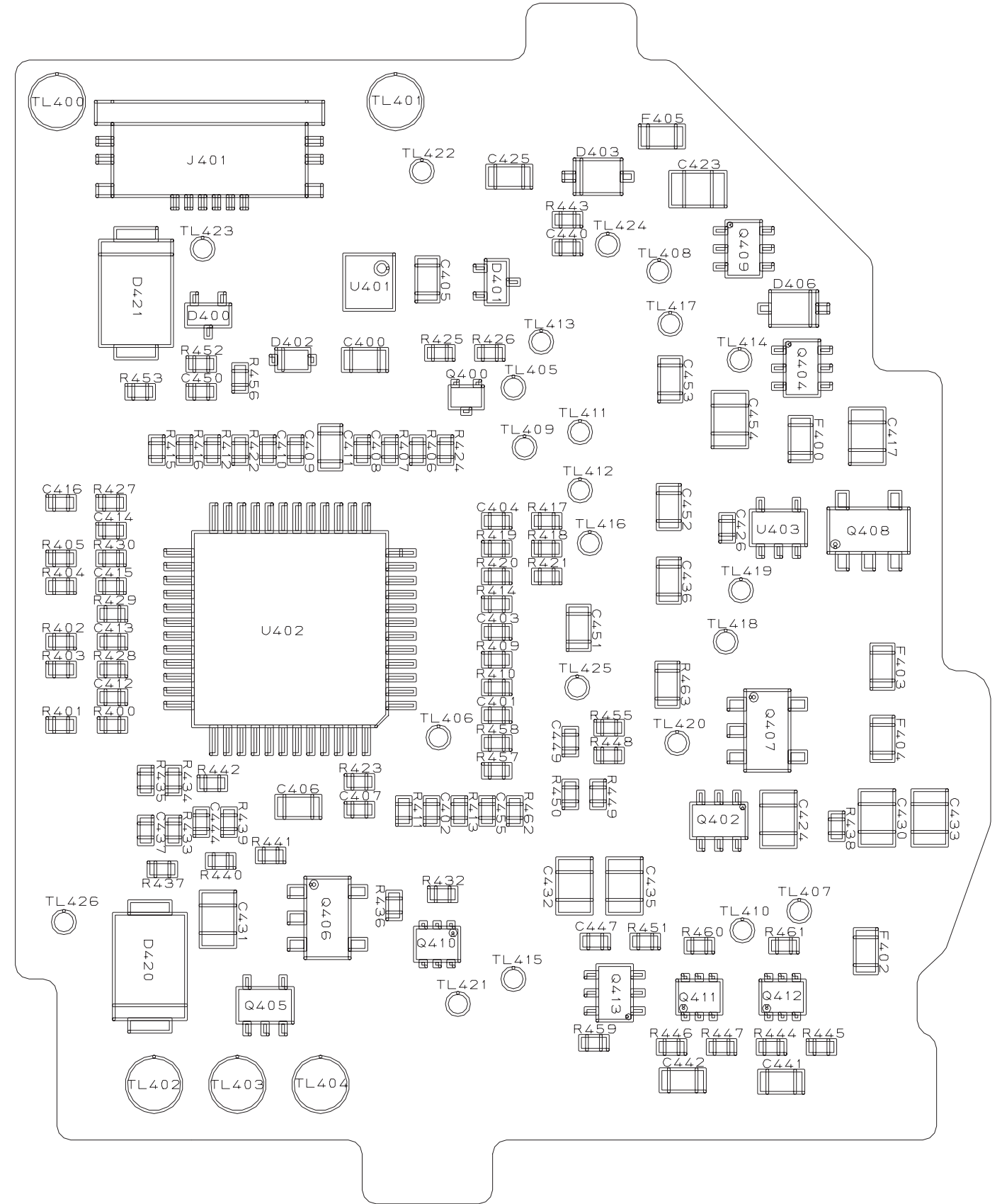
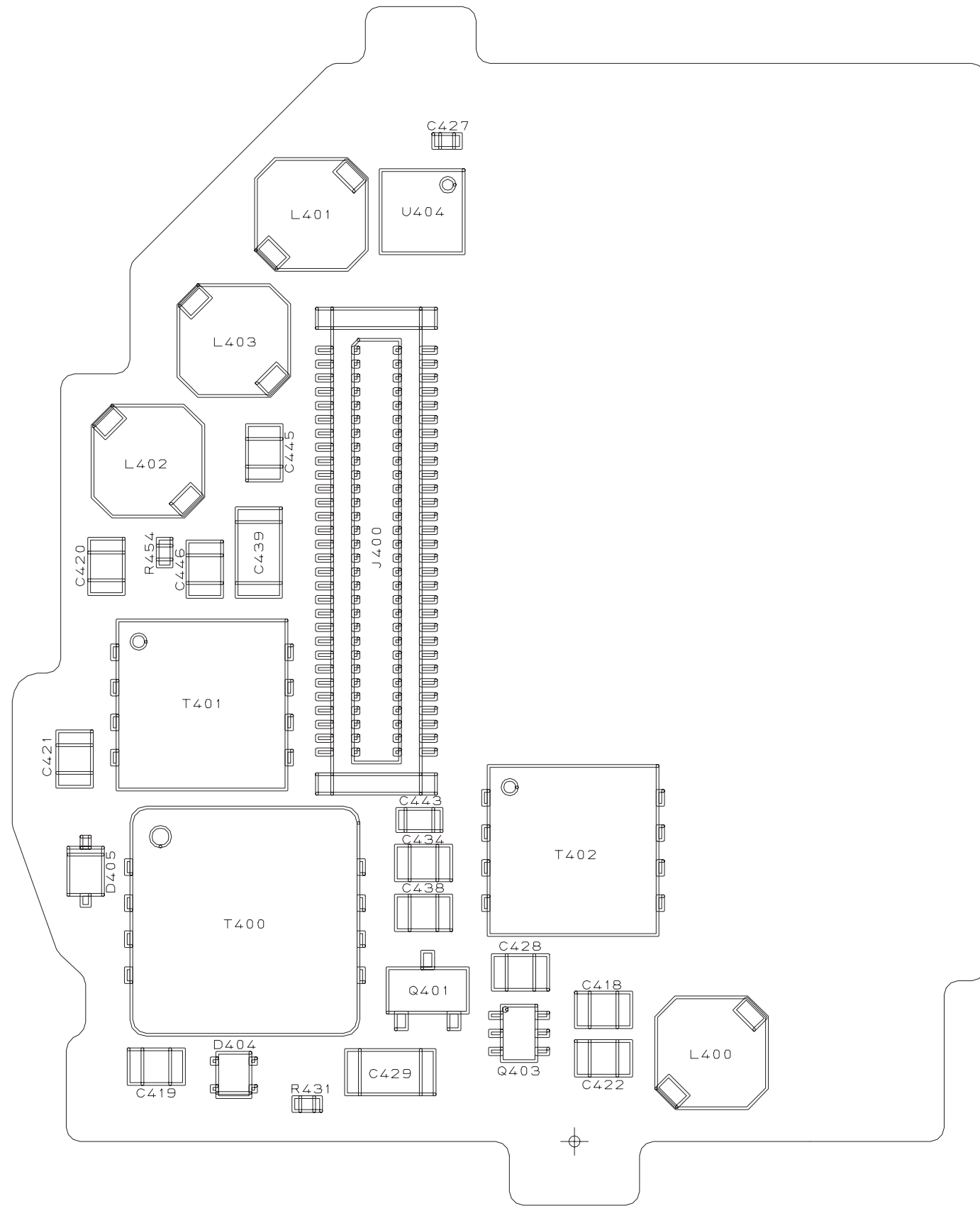



# μ-30 / μ[mju:] 410 / Stylus410 DIGITAL MOUNTING DIAGRAM : SW-FPCA

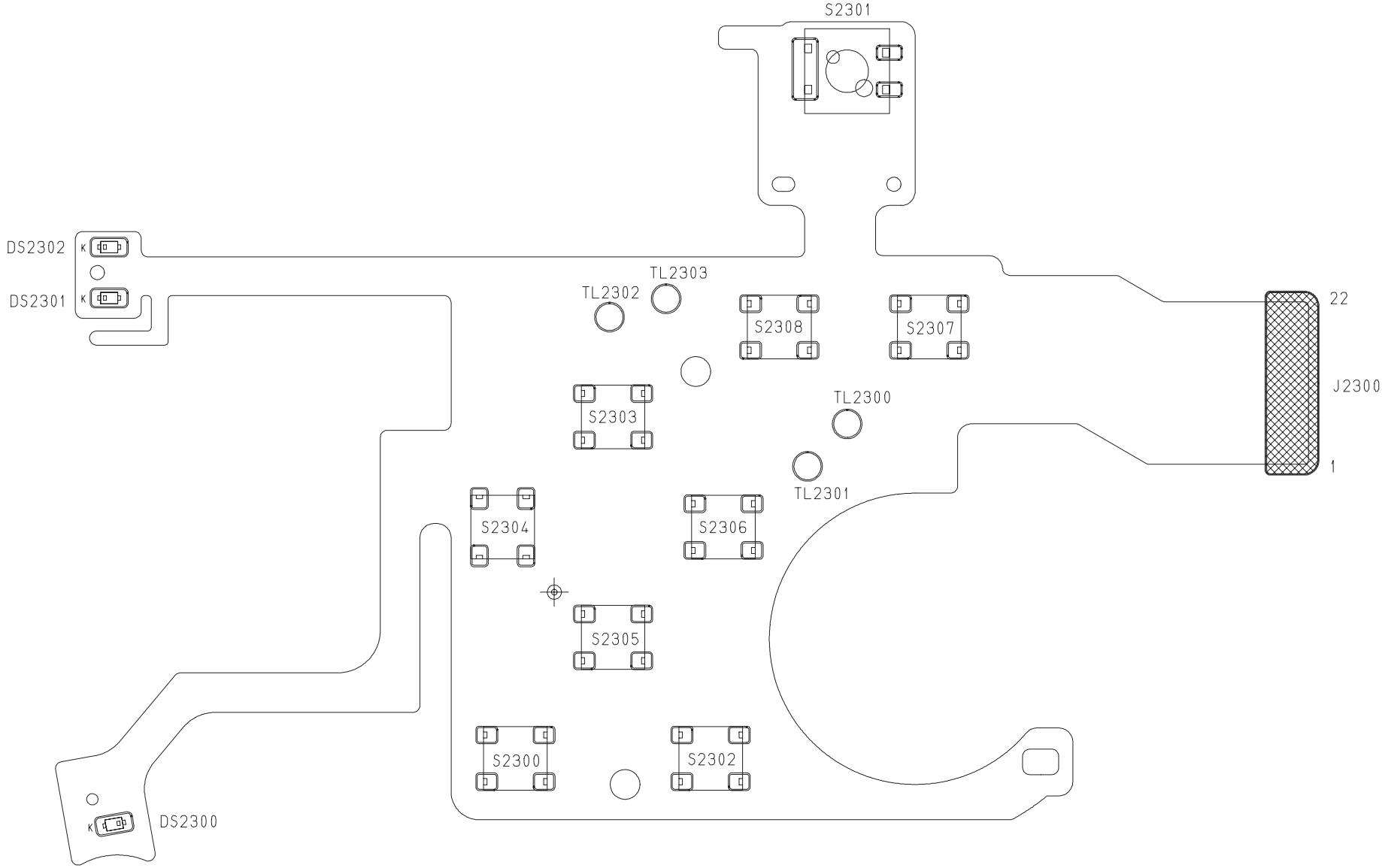

μ-30 / μ[mju:] 410 / Stylus410 DIGITAL MOUNTING DIAGRAM : CCD-FPCA

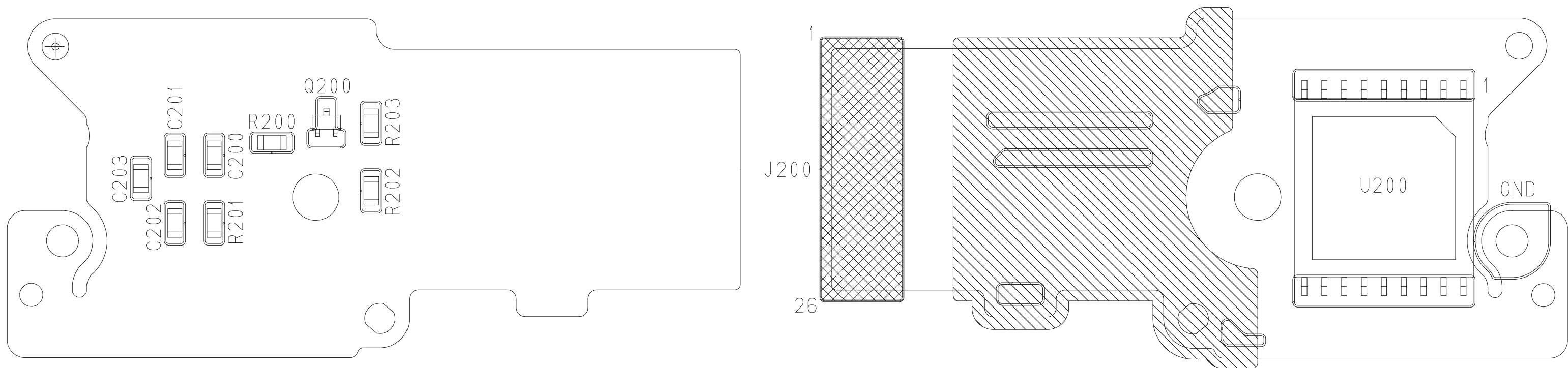

# μ-30 / μ[mju:] 410 / Stylus410 DIGITAL MOUNTING DIAGRAM : FL-PCA

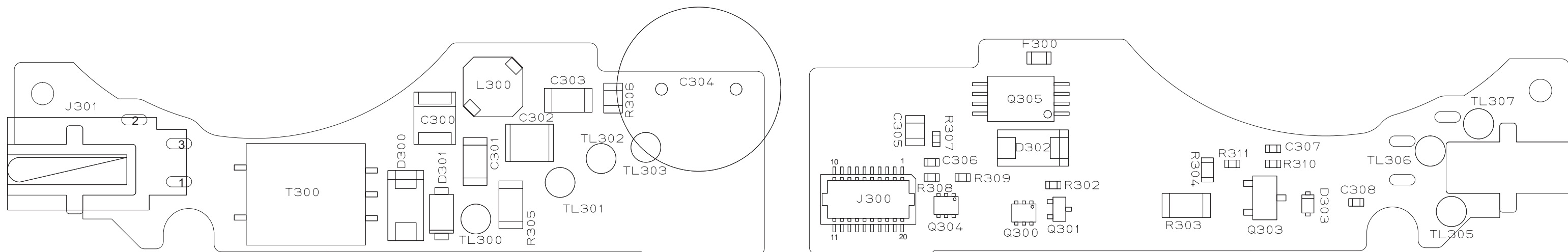

# μ-30 / μ[mju:] 410 / Stylus410 DIGITAL MOUNTING DIAGRAM : LD FPCA

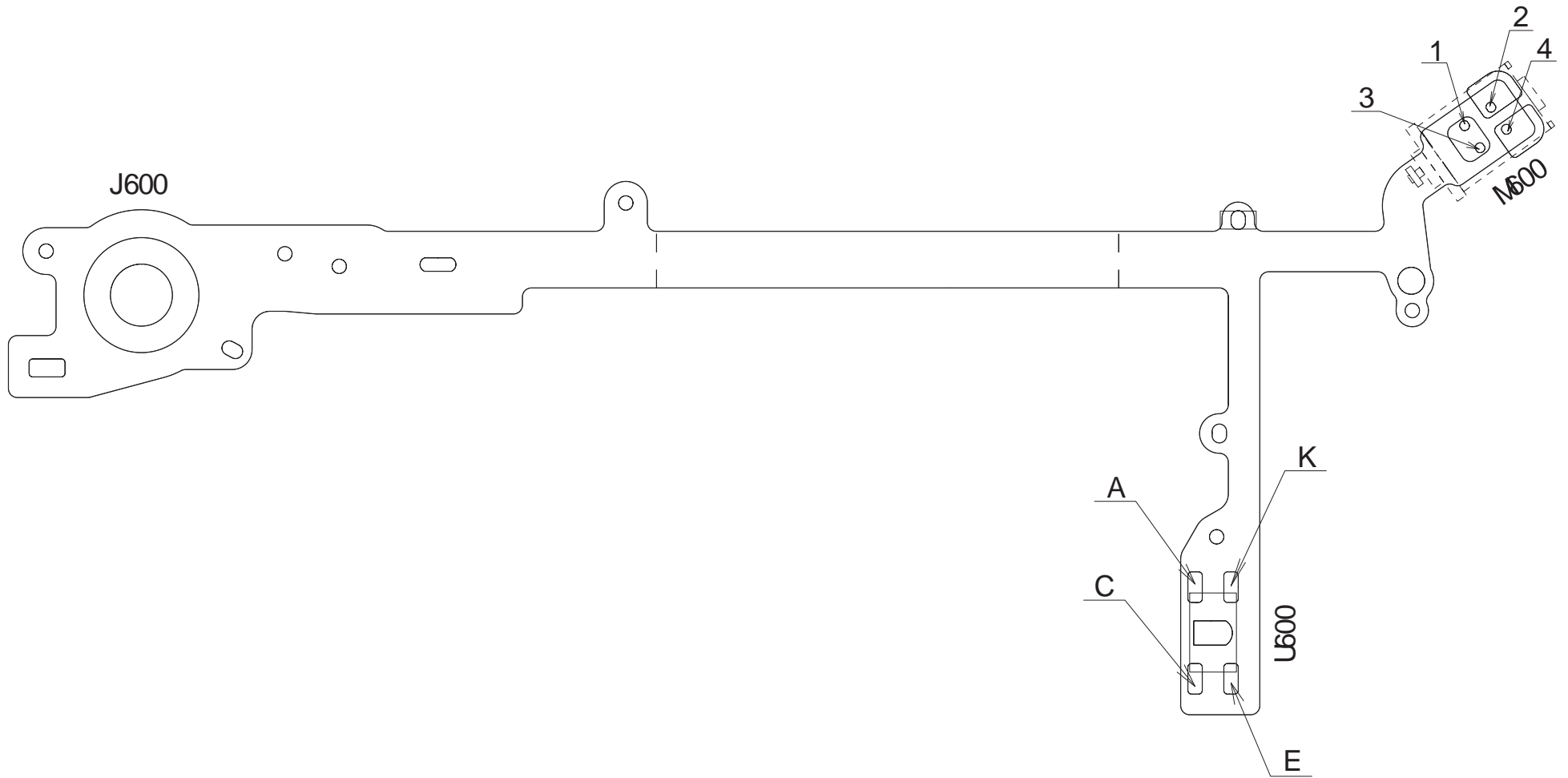

# μ-30 / μ[mju:] 410 / Stylus410 DIGITAL MOUNTING DIAGRAM : Z FPCA

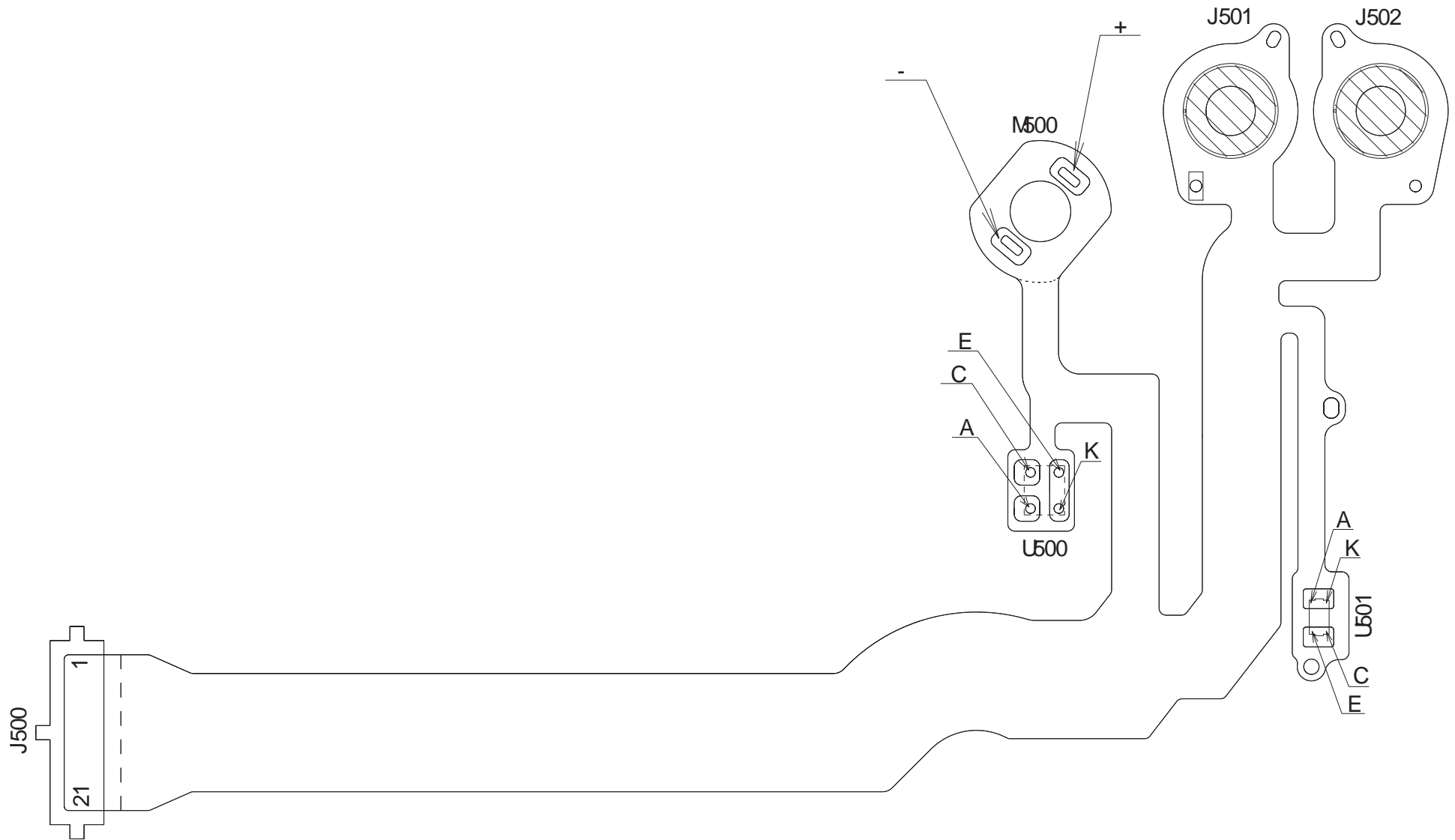

A

B

C

D

1

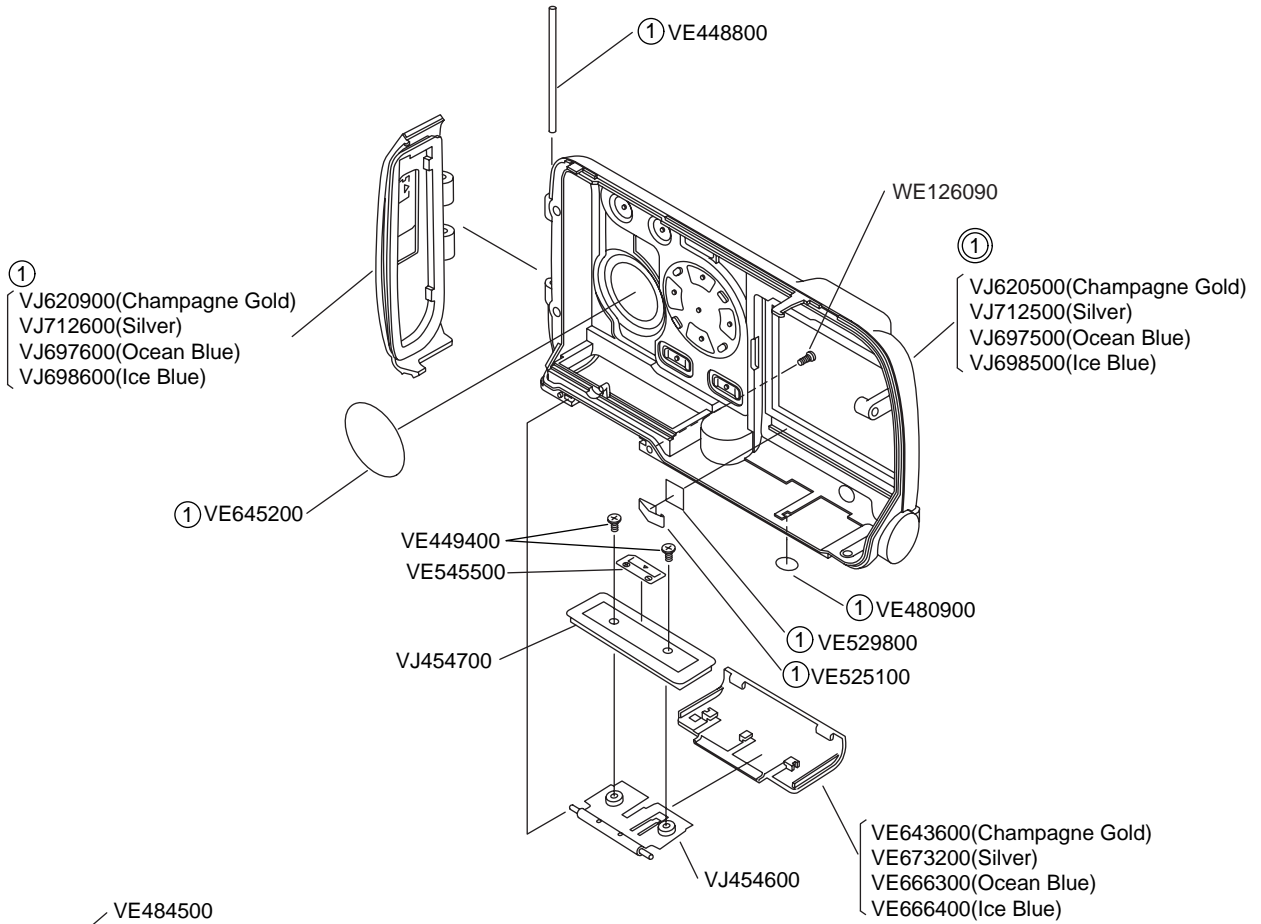

2

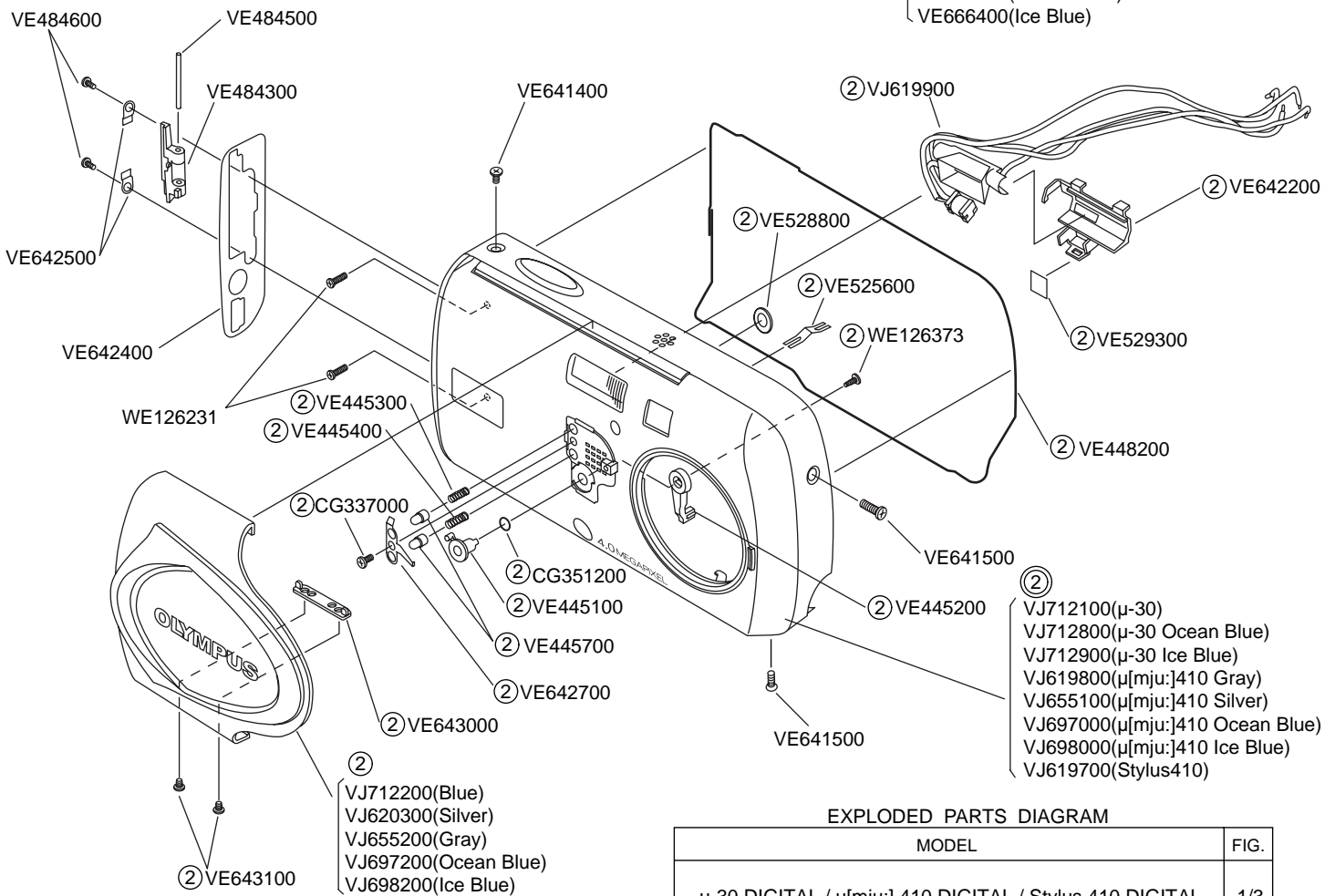

3

4

## EXPLODED PARTS DIAGRAM

MODEL	FIG.
$\mu$ -30 DIGITAL / $\mu$ [mju:] 410 DIGITAL / Stylus 410 DIGITAL	1/3
OLYMPUS CORPORATION	

Ver.1  
2004.03

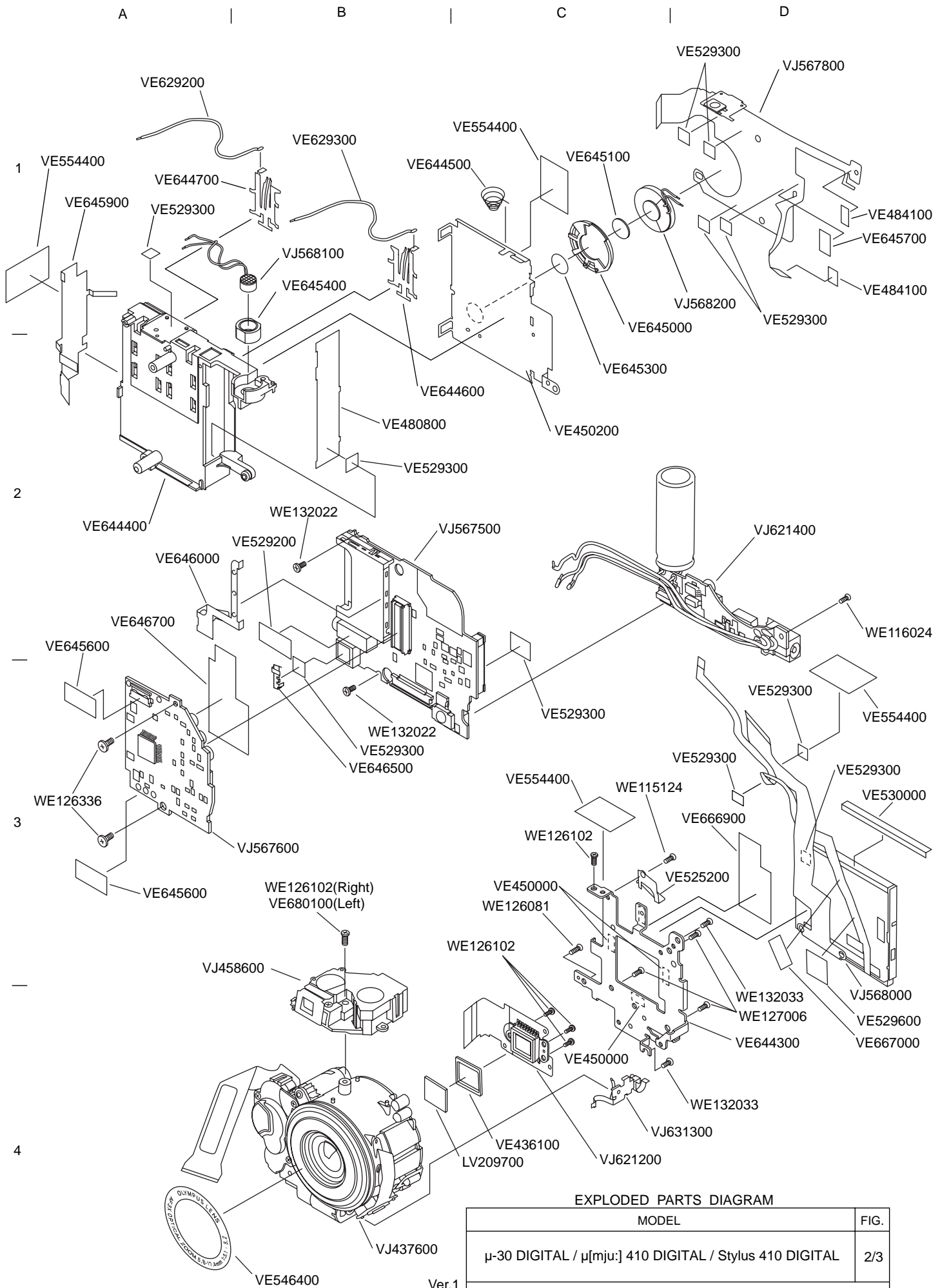

EXPLODED PARTS DIAGRAM

MODEL	FIG.
μ-30 DIGITAL / μ[mju:] 410 DIGITAL / Stylus 410 DIGITAL	2/3
<b>OLYMPUS CORPORATION</b>	

Ver.1  
2004.03

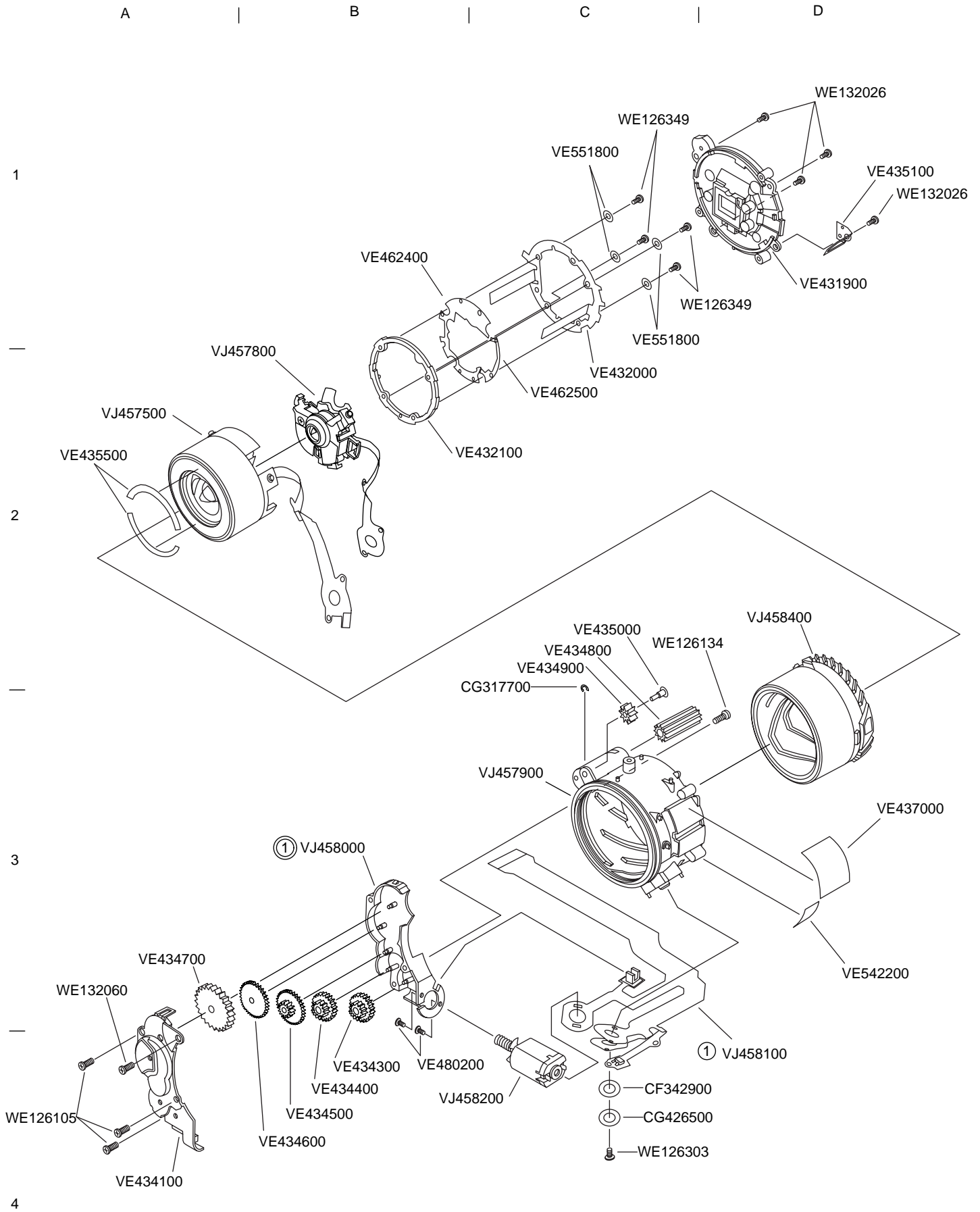

EXPLODED PARTS DIAGRAM

MODEL	FIG.
μ-30 DIGITAL / μ[mju:] 410 DIGITAL / Stylus 410 DIGITAL	3/3
<b>OLYMPUS CORPORATION</b>	

Ver.1  
2004.03



## PARTS LIST

μ-30/μ[mju:] 410/Stylus 410 DIGITAL

REF NO	PARTS NO	DESCRIPTION	REMARKS	NOTE
	CF342900	ConnectRubber	3-C4	
	CG317700	3GStoper	3-C2	
	CG337000	THB1640	1-B4	NEW
	CG351200	BK RING	1-B4	
	CG426500	ConnectPlate	3-C4	
	LV209700	106LPF	2-C4	
	VE431900	Cholder	3-D1	
	VE432000	FloatKey	3-C2	
	VE432100	FloatKeyGuide	3-C2	
	VE434100	GearCover	3-A4	
	VE434300	106ZWheel	3-B4	
	VE434400	106ZGear1	3-B4	
	VE434500	106ZGear2	3-B4	
	VE434600	106ZGear3	3-B4	
	VE434700	106Z Idle	3-A3	
	VE434800	106LongGear	3-C2	
	VE434900	106FIdle	3-C2	
	VE435000	FIdleShaft	3-C2	
	VE435100	PRHolder	3-D1	
	VE435500	1ZTape1	3-A2	
	VE436100	SPACER	2-C4	
	VE436700	LD-FPCTape1	LENS#	
	VE437000	FPCTape	3-D3	
	VE445100	BarrierKnob	1-B4	
	VE445200	Barrier-SW-Arm	1-D4	
	VE445300	BarrierClickSpring-A	1-B3	
	VE445400	BarrierClickSpring-B	1-B3	
	VE445700	BarrierClickBall	1-B4	
	VE448200	StringRubber	1-D3	
	VE448800	CardCoverShaft	1-C1	
	VE449400	BatteryCoverScrew	1-B2	
	VE450000	MonitorTape-A	2-C3,2-C4	
	VE450200	BatteryCasePlate	2-C2	
	VE462400	FloatAperture1	3-B1	
	VE462500	FloatAperture2	3-C2	
	VE480200	U1.4X1.6NR	3-B4	
	VE480600	S-ApTape1	LENS#	
	VE480800	BatCaseCover	2-B2	
	VE480900	BackCabiCover	1-D2	
	VE484100	F-LED Tape	2-D1	
	VE484300	CardInnerCover	1-A3	
	VE484500	InnerCoverShaft	1-A3	
	VE484600	ShaftScrew	1-A3	
	VE525100	BackContact	1-D2	
	VE525200	TFTContact	2-D3	
	VE525600	F-Bcontact	1-C3	
	VE528800	Self-Cushion	1-C3	
	VE529200	VJ-Tape	2-B2	NEW
	VE529300	SWFPCTape	1-D3,etc.	NEW
	VE529600	TFT-FPCTape	2-D4	
	VE529800	BackContactTape	1-D2	
	VE530000	TFT-TOP-Tape	2-D3	
	VE542200	PR-Tape	3-D3	

## PARTS LIST

μ-30/μ[mju:] 410/Stylus 410 DIGITAL

REF NO	PARTS NO	DESCRIPTION	REMARKS	NOTE
	VE542500	WormShaft	LENS#	NEW
	VE545500	Battery Label	1-B2	
	VE546400	1061ZCoverRing	2-B4	
	VE551800	FloatAperture3	3-C1	
	VE554400	TFT-ProtectTape	2-A1, etc.	
	VE629200	199BATT1-HS	2-A1	NEW
	VE629300	199BATT2-HS	2-B1	NEW
	VE641400	199MDL-MetalScrew1	1-B3	NEW
	VE641500	199MDL-MetalScrew2	1-C4,1-D4	NEW
	VE642200	199FlashReflectorBase	1-D3	NEW
	VE642400	199JackCoverSheet	1-A3	NEW
	VE642500	199ShaftPlate	1-A3	NEW
	VE642700	199BRContact	1-B4	NEW
	VE643000	BarrierGuide	1-B4	NEW
	VE643100	BarrierScrew	1-A4	NEW
	VE643600	199BatteryOuterCover (Champagne Gold)	1-D2	NEW
	VE644300	199BodyFrame	2-D4	NEW
	VE644400	199BatoryCase	2-A2	NEW
	VE644500	199BatterySpring	2-B1	NEW
	VE644600	199BatteryContact-A	2-B2	NEW
	VE644700	199BatteryContact-B	2-A1	NEW
	VE645000	SP-Base	2-C1	NEW
	VE645100	SP-Cushion	2-C1	NEW
	VE645200	SP-Sheet	1-B2	NEW
	VE645300	SP-Tape	2-C2	NEW
	VE645400	MIC-Rubber	2-B1	NEW
	VE645600	STLW-Tape	2-A2,2-A3	NEW
	VE645700	SW-FPCA-Tape2	2-D1	NEW
	VE645900	199USB-Contact	2-A1	NEW
	VE646000	XD-Contact	2-A2	NEW
	VE646500	199USB-Contact2	2-B3	NEW
	VE646700	199MC-ContactTape	2-A2	NEW
	VE666300	199BatteryOuterCover OB (Ocean Blue)	1-D2	NEW
	VE666400	199BatteryOuterCover IB (Ice Blue)	1-D3	NEW
	VE666900	199TFT-FPC-Tape1	2-D3	NEW
	VE667000	199TFT-FPC-Tape2	2-D4	NEW
	VE673200	199BatteryOuterCover SL (Silver)	1-D2	NEW
	VE680100	PUTB1635L	2-B3	NEW
	VJ437600	Lens-ASSY	2-B4	
	VJ454600	BattCoverBase-ASSY-2	1-C2	
	VJ454700	BattInnerCover-ASSY	1-B2	
	VJ457500	1ZFrame-ASSY	3-A2	
	VJ457800	2ZFrame-ASSY	3-B2	
	VJ457900	BaseFrame-ASSY	3-C3	
	VJ458000	GearCase-ASSY	3-B3	
	VJ458100	106Z-FPCA	3-D4	
	VJ458200	Zmotor-ASSY	3-C4	
	VJ458400	CamBarrel-ASSY	3-D2	
	VJ458600	106Finder-ASSY	2-B3	
	VJ567500	199MC-PCA	2-C2	NEW
	VJ567600	199PW-PCA	2-B3	NEW
	VJ567800	199SW-FPCA	2-D1	NEW
	VJ568000	199TFT-UT	2-D4	NEW

## PARTS LIST

μ-30/μ[mju:] 410/Stylus 410 DIGITAL

REF NO	PARTS NO	DESCRIPTION	REMARKS	NOTE
	VJ568100	199MIC-UT	2-B1	NEW
	VJ568200	199SP-UT	2-D1	NEW
	VJ619700	199FrontCover-ASSY U (Stylus 410)	1-D4	NEW
	VJ619800	199FrontCover-ASSY E (μ[mju:]410 Gray)	1-D4	NEW
	VJ619900	199FlashReflector-ASSY	1-D3	NEW
	VJ620300	199Barrier-ASSY S (Silver)	1-B4	NEW
	VJ620500	199BackCover-ASSY (Champagne Gold)	1-D1	NEW
	VJ620900	199CardCover-ASSY (Champagne Gold)	1-A1	NEW
	VJ621200	199CCD-FPCA-2	2-C4	NEW
	VJ621400	199FL-PCA-2	2-D2	NEW
	VJ631300	DCContact-ASSY	2-D4	NEW
	VJ655100	199FrontCover-ASSY G (μ[mju:]410 Silver)	1-D4	NEW
	VJ655200	199Barrier-ASSY GR (Gray)	1-B4	NEW
	VJ697000	199FrontCover-ASSY OB (μ[mju:]410 Ocean Blue)	1-D4	NEW
	VJ697200	199Barrier-ASSY OB (Ocean Blue)	1-B4	NEW
	VJ697500	199BackCover-ASSY OB (Ocean Blue)	1-D1	NEW
	VJ697600	199CardCover-ASSY OB (Ocean Blue)	1-A1	NEW
	VJ698000	199FrontCover-ASSY IB (μ[mju:]410 Ice Blue)	1-D4	NEW
	VJ698200	199Barrier-ASSY IB (Ice Blue)	1-B4	NEW
	VJ698500	199BackCover-ASSY IB (Ice Blue)	1-D1	NEW
	VJ698600	199CardCover-ASSY IB (Ice Blue)	1-A1	NEW
	VJ712100	199FrontCover-ASSY J (μ-30)	1-D4	NEW
	VJ712200	199Barrier-ASSY SL (Blue)	1-B4	NEW
	VJ712500	199BackCover-ASSY SL (Silver)	1-D1	NEW
	VJ712600	199CardCover-ASSY SL (Silver)	1-A1	NEW
	VJ712800	199FrontCover-ASSY OB-J (μ-30 Ocean Blue)	1-D4	NEW
	VJ712900	199FrontCover-ASSY IB-J (μ-30 Ice Blue)	1-D4	NEW
	VT421600	CHINA Label		
	VT688900	Rated Label J		NEW
	VT689000	Rated Label U		NEW
	VT689100	Rated Label E		NEW
	VT689200	Rated Label G1		NEW
	VT689300	Rated Label A1		NEW
	VT689400	Rated Label T1		NEW
	VT689500	Rated Label H1		NEW
	VT689700	Rated Label K		NEW
	VT689800	Rated Label C		NEW
	VT808800	Rated Label KJ		NEW
	VT808900	Rated Label KU		NEW
	WE115124	PUK1.6x1.6SN	2-C3	
	WE116024	3PUK1.4x3SN	2-D2	
	WE126081	PUTB1.6x4SN	2-C3	
	WE126090	PUTB1.4x4SN	1-D1	
	WE126102	PUTB1.6x3.5SN	2-B3,etc.	
	WE126105	PUTB1.6x4SB	3-A4	
	WE126134	PUTB1.6x4.5SB	3-C2	
	WE126231	PUTB1.6-250	1-A3	
	WE126303	PUTB1.6x630SN	3-C4	
	WE126336	PUTB1.6 X 435SN	2-A3	
	WE126349	PUTB1.4x2.2SB	3-C1	
	WE126373	PUTB1.4x235SB	1-D3	
	WE127006	PSTB1.6x3SN	2-D4	
	WE132022	3PUTB1.6x3.5SN	2-B2,2-B3	

## PARTS LIST

μ-30/μ[mju:] 410/Stylus 410 DIGITAL

REF NO	PARTS NO	DESCRIPTION	REMARKS	NOTE
	WE132026	3PUTB1.6x4SN	3-D1	
	WE132033	3PUTB1.6x5SN	2-D4,2-D4	
	WE132060	3PUTB1.4x4SN	3-A3	