

DSC-HX1

SERVICE MANUAL

LEVEL 2

Ver. 1.2 2009.08

Revision History

Internal memory
ON BOARD

Revised-1

Replacement of the previously issued
SERVICE MANUAL 9-852-686-32
with this manual.



US Model
Canadian Model
AEP Model
UK Model
E Model
Australian Model
Hong Kong Model
Chinese Model
Korea Model
Argentine Model
Japanese Model
Tourist Model

Link

SPECIFICATIONS	BLOCK DIAGRAMS	PRINTED WIRING BOARDS
SERVICE NOTE	FRAME SCHEMATIC DIAGRAM	REPAIR PARTS LIST
DISASSEMBLY	SCHEMATIC DIAGRAMS	

• Precautions on Replacing the SY-218 Board

The components identified by
mark \triangle or dotted line with
mark \triangle are critical for safety.
Replace only with part num-
ber specified.

Les composants identifiés par une
marque \triangle sont critiques pour la
sécurité.
Ne les remplacer que par une pièce
portant le numéro spécifié.

DIGITAL STILL CAMERA

SONY®



Cyber-shot



SPECIFICATIONS

Camera

[System]

Image device: 7.63 mm (1/2.4 type) Exmor CMOS sensor

Total pixel number of camera:
Approx. 10.3 Megapixels

Effective pixel number of camera:
Approx. 9.1 Megapixels

Lens: G-series 20x zoom lens
f = 5.0 mm – 100.0 mm (28 mm – 560 mm (35 mm film equivalent))
F2.8 (W) – F5.2 (T)
Shooting movies (16:9): 31 mm – 620 mm
Shooting movies (4:3): 38 mm – 760 mm

Exposure control: Automatic exposure, Shutter speed priority, Aperture priority, Manual exposure, Scene selection (10 modes)

White balance: Automatic, Daylight, Cloudy, Fluorescent 1,2,3, Incandescent, Flash, One push

File format (DCF compliant):
Still images: JPEG (DCF Ver. 2.0, Exif Ver. 2.21, MPF Baseline) compliant, DPOF compatible
Movies: MPEG-4 AVC/H.264 compliant (stereo)

Recording media: Internal Memory (approx. 11 MB), "Memory Stick Duo" media

Flash: Flash range (ISO sensitivity (Recommended Exposure Index) set to Auto):
Approx. 0.3 m to 9.2 m (11 7/8 inches to 30 feet 2 1/4 inches) (W)/
approx. 1.5 m to 5.1 m (4 feet 11 1/8 inches to 16 feet 8 7/8 inches) (T)

Viewfinder: Electric view finder (color)

[Input and Output connectors]

Multi use terminal Type2d: (AV-out/SD/HD Component)/HDMI/USB)
Video output
Audio output (stereo)
HDMI output
USB communication

USB communication:
Hi-Speed USB (USB 2.0 compliant)

[LCD screen]

LCD panel: 7.5 cm (3.0 type) TFT drive
Total number of dots: 230 400 (960 × 240) dots

[Finder]

Panel: 0.5 cm (0.2 type)
Total number of dots:
Approx. 201 000 dots equivalent

[Power, general]

Power: Rechargeable battery pack
NP-FH50, 6.8 V
Power consumption (during shooting, LCD screen on): 1.2 W

Operating temperature: 0 °C to 40 °C (32 °F to 104 °F)

Storage temperature: –20 °C to +60 °C (–4 °F to +140 °F)

Dimensions:
114.5 × 82.8 × 91.8 mm (4 5/8 × 3 3/8 × 3 5/8 inches) (W/H/D, excluding protrusions)

Mass (including NP-FH50 battery pack and "Memory Stick Duo" media):
Approx. 504 g (1lb 1.8 oz)

Microphone: Stereo

Speaker: Monaural

Exif Print: Compatible

PRINT Image Matching III: Compatible

PictBridge: Compatible

BC-VH1 battery charger

Power requirements: AC 100 V to 240 V, 50 Hz/60 Hz, 4 W

Output voltage: DC 8.4 V, 0.28 A

Operating temperature: 0 °C to 40 °C (32 °F to 104 °F)

Storage temperature: –20 °C to +60 °C (–4 °F to +140 °F)

Dimensions: Approx. 60 × 25 × 95 mm (2 3/8 × 1 × 3 3/4 inches) (W/H/D)

Mass: Approx. 75 g (2.6 oz)

Rechargeable battery pack NP-FH50

Used battery: Lithium-ion battery

Maximum voltage: DC 8.4 V

Nominal voltage: DC 6.8 V

Maximum charge current: 1.75 A

Maximum charge voltage: DC 8.4 V

Capacity:
typical: 6.1 Wh (900 mAh)
minimum: 5.9 Wh (870 mAh)

Design and specifications are subject to change without notice.

CAUTION

Danger of explosion if battery is incorrectly replaced.
 Replace only with the same or equivalent type.
 Dispose of used batteries according to the instructions.

SAFETY-RELATED COMPONENT WARNING!!

COMPONENTS IDENTIFIED BY MARK \triangle OR DOTTED LINE WITH MARK \triangle ON THE SCHEMATIC DIAGRAMS AND IN THE PARTS LIST ARE CRITICAL TO SAFE OPERATION. REPLACE THESE COMPONENTS WITH SONY PARTS WHOSE PART NUMBERS APPEAR AS SHOWN IN THIS MANUAL OR IN SUPPLEMENTS PUBLISHED BY SONY.

ATTENTION AU COMPOSANT AYANT RAPPORT À LA SÉCURITÉ!

LES COMPOSANTS IDENTIFIÉS PAR UNE MARQUE \triangle SUR LES DIAGRAMMES SCHÉMATIQUES ET LA LISTE DES PIÈCES SONT CRITIQUES POUR LA SÉCURITÉ DE FONCTIONNEMENT. NE REMPLACER CES COMPOSANTS QUE PAR DES PIÈCES SONY DONT LES NUMÉROS SONT DONNÉS DANS CE MANUEL OU DANS LES SUPPLÉMENTS PUBLIÉS PAR SONY.

SAFETY CHECK-OUT

After correcting the original service problem, perform the following safety checks before releasing the set to the customer.

1. Check the area of your repair for unsoldered or poorly-soldered connections. Check the entire board surface for solder splashes and bridges.
2. Check the interboard wiring to ensure that no wires are "pinched" or contact high-wattage resistors.
3. Look for unauthorized replacement parts, particularly transistors, that were installed during a previous repair. Point them out to the customer and recommend their replacement.
4. Look for parts which, through functioning, show obvious signs of deterioration. Point them out to the customer and recommend their replacement.
5. Check the B+ voltage to see it is at the values specified.
6. Flexible Circuit Board Repairing
 - Keep the temperature of the soldering iron around 270°C during repairing.
 - Do not touch the soldering iron on the same conductor of the circuit board (within 3 times).
 - Be careful not to apply force on the conductor when soldering or unsoldering.

Unleaded solder

Boards requiring use of unleaded solder are printed with the lead-free mark (LF) indicating the solder contains no lead.
 (Caution: Some printed circuit boards may not come printed with the lead free mark due to their particular size.)

 : LEAD FREE MARK

Unleaded solder has the following characteristics.

- Unleaded solder melts at a temperature about 40°C higher than ordinary solder.
 Ordinary soldering irons can be used but the iron tip has to be applied to the solder joint for a slightly longer time.
 Soldering irons using a temperature regulator should be set to about 350°C.
 Caution: The printed pattern (copper foil) may peel away if the heated tip is applied for too long, so be careful!
- Strong viscosity
 Unleaded solder is more viscous (sticky, less prone to flow) than ordinary solder so use caution not to let solder bridges occur such as on IC pins, etc.
- Usable with ordinary solder
 It is best to use only unleaded solder but unleaded solder may also be added to ordinary solder.

注意

電池の交換は、正しく行わないと破裂する恐れがあります。
電池を交換する場合には必ず同じ型名の電池又は同等品と交換してください。
使用済み電池は、取扱指示に従って処分してください。

サービス、点検時には次のことにご注意下さい。

1. 注意事項をお守りください。
サービスのとき特に注意を要する箇所については、キャビネット、シャーシ、部品などにラベルや捺印で注意事項を表示しています。これらの注意書き及び取扱説明書等の注意事項を必ずお守り下さい。
2. 指定部品のご使用を
セットの部品は難燃性や耐電圧など安全上の特性を持ったものとなっています。従って交換部品は、使用されていたものと同じ特性の部品を使用して下さい。特に回路図、部品表に△印で指定されている安全上重要な部品は必ず指定のものをご使用下さい。
3. 部品の取付けや配線の引きまわしはもとどおり
安全上、チューブやテープなどの絶縁材料を使用したり、プリント基板から浮かして取付けた部品があります。また内部配線は引きまわしやクランパによって発熱部品や高圧部品に接近しないよう配慮されていますので、これらは必ずもとどおりにして下さい。
4. サービス後は安全点検を
サービスのために取外したネジ、部品、配線がもとどおりになっているか、またサービスした箇所の周辺を劣化させてしまったところがないかなどを点検し、安全性が確保されていることを確認して下さい。
5. チップ部品交換時の注意
 - 取外した部品は再使用しないで下さい。
 - タンタルコンデンサのマイナス側は熱に弱いため交換時は注意して下さい。
6. フレキシブルプリント基板の取扱いについて
 - コテ先温度を270℃前後にして行なって下さい。
 - 同一パターンに何度もコテ先を当てないで下さい。
(3回以内)
 - パターンに力が加わらないよう注意して下さい。
7. 無鉛半田について
無鉛半田を使用している基板には、無鉛 (Lead Free) を意味するレッドフリーマークがプリントされています。
(注意：基板サイズによっては、無鉛半田を使用してもレッドフリーマークがプリントされていないものがあります)
：レッドフリーマーク
無鉛半田には、以下の特性があります。
 - 融点が従来の半田よりも約40℃高い。
従来の半田こてをそのまま使用することは可能ですが、少し長めにこてを当てる必要があります。
温度調節機能のついた半田こてを使用する場合、約350℃に設定して下さい。
注意：半田こてを長く当てすぎると、基板のパターン (銅箔) がはがれてしまうことがありますので、注意して下さい。
 - 粘性が強い
従来の半田よりも粘性が強いため、IC端子などが半田ブリッジしないように注意して下さい。
 - 従来の半田と混ぜて使用可能
無鉛半田には無鉛半田を追加するのが最適ですが、従来の半田を追加しても構いません。

1-1. PRECAUTION ON REPLACING THE SY-218 BOARD

Restore Data

When you replace to the repairing board, get the acquire data from the former needed for the adjustment from. Start the Adjust Manual in the Adjust Station and perform “Restore Data” to get the data. The data getting for this model is as follows.

- USB Serial No.
- Angular Velocity Sensor Sensitivity Adjustment (Dp/Dy Data)
- Wide Limit Adjustment

Note: When you cannot read data from the former replace the same time SY-218 board and lens.

Destination Data

When you replace to the repairing board, the written destination data of repairing board also might be changed to original setting. Start the Adjust Manual in the Adjust Station and execute the “Destination Data Write”.

USB Serial No.

The set is shipped with a unique ID (USB Serial No.) written in it. This ID has not been written in a new board for service, and therefore it must be entered after the board replacement. Start the Adjust Manual in the Adjust Station and execute the “USB Serial No. Input”.

Angular Velocity Sensor

When you replace to the repairing board, write down the sensitivity displayed on the angular velocity sensor (SE401, SE402). Start the Adjust Manual in the Adjust Station and execute the “Angular Velocity Sensor Sensitivity Adjustment”, input the data written down.

SY-218 BOARD (SIDE B)

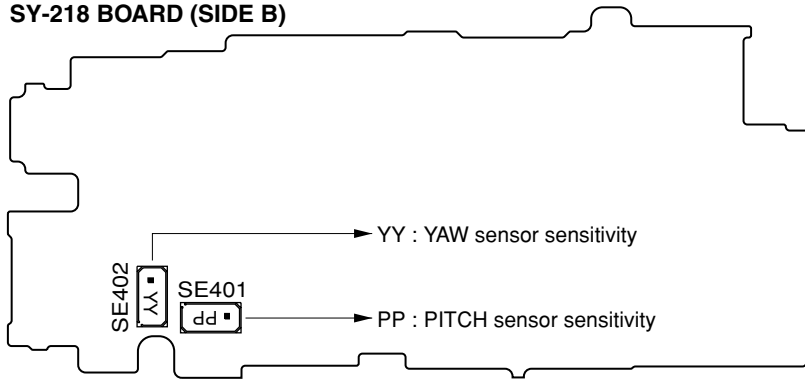

Note: The sensor sensitivity of SE401, SE402 of SY-218 board are written only repair parts.

1-2. PRECAUTION ON REPLACING THE LENS

When replacing the lens, write down the wide limit data given on the lens for service. Start the Adjust Manual in the Adjust Station and execute the “Wide Limit Adjustment”, input the data written down.

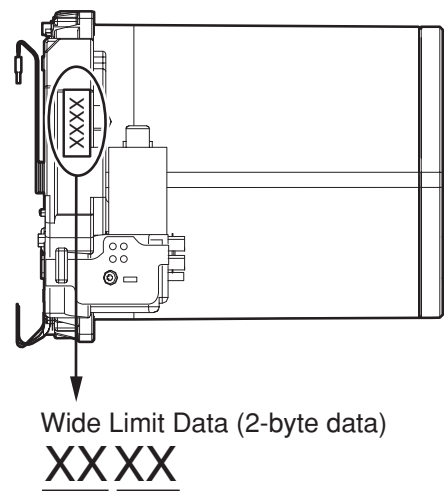

Note: The wide limit data of lens is written only repair parts.

1-3. METHOD FOR COPYING OR ERASING THE DATA IN INTERNAL MEMORY



The data can be copied/erased by the operations on the HOME screen. (When erasing the data, execute formatting the internal memory.)

Note 1: When replacing the SY-218 board, erase the data in internal memory of the board before replacement.

Note 2: When replacing the SY-218 board, execute formatting and initialize the internal memory after replacement.

Method for Copying the Data in Internal Memory

Copies all images in the internal memory to a “Memory Stick Duo” media.



- 1 Insert a “Memory Stick Duo” media with sufficient free capacity into the camera
- 2 MENU →  (Settings) →  (“Memory Stick” Tool) → [Copy] → [OK] → ● on the control button

Notes

- Use a fully charged battery pack. If you attempt to copy image files using a battery pack with little remaining charge, the battery pack may run out, causing copying to fail or possibly corrupting the data.
- Images cannot be copied individually.
- The original images in the internal memory are retained even after copying. To delete the contents of the internal memory, remove the “Memory Stick Duo” media after copying, then format the internal memory ([Format] in [Internal Memory Tool]).
- A new folder is created on the “Memory Stick Duo” media and all the data will be copied to it. You cannot choose a specific folder and copy images to it.

Method for Formatting the Internal Memory

Formats the “Memory Stick Duo” media or the internal memory. A commercially available “Memory Stick Duo” media is already formatted, and can be used immediately.

- 1 MENU →  (Settings) →  (“Memory Stick” Tool) or  (Internal Memory Tool) → [Format] → [OK] → ● on the control button

Note

- Note that formatting permanently erases all data including even protected images.

1-4. HOW TO WRITE DATA TO INTERNAL MEMORY

Usually, the camera has been set so as to disable the data writing from the PC to the internal memory of the camera. This setting must be changed temporarily when the data is to be written to the internal memory such as a case after the board replacement. To change settings is enabled with using the writing enabler tool (Write Enable Tool) on the Adjust Manual is activating from the Adjust Station.

Data Writing Method

- 1) Start the Adjust Manual from the Adjust Station.
- 2) Click  (Write Enable Tool) button.
- 3) Click “Active Write Enable Mode” button.

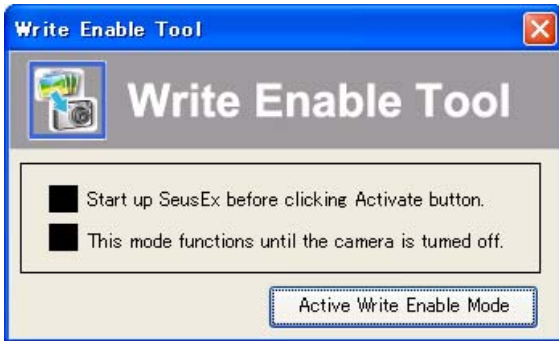

- 4) Upon completion of the setting change, the following message will be displayed.



- 5) Return the driver to the original one, and connect the PC to the camera (USB mode: Mass Storage).
- 6) Write the data read out into the PC to the internal memory of the camera.
- 7) Disconnect the PC from the camera, and turn off the camera.

Note: By turning off the camera, the write enable setting is reset.

1-5. SELF-DIAGNOSIS FUNCTION

1-5-1. Self-diagnosis Function

When problems occur while the unit is operating, the self-diagnosis function starts working, and displays on the LCD screen what to do.

Details of the self-diagnosis functions are provided in the Instruction manual.

1-5-2. Self-diagnosis Display

When problems occur while the unit is operating, the LCD screen shows a 4-digit display consisting of an alphabet and numbers, which blinks at 3.2 Hz. This 5-character display indicates the “repaired by:”, “block” in which the problem occurred, and “detailed code” of the problem.

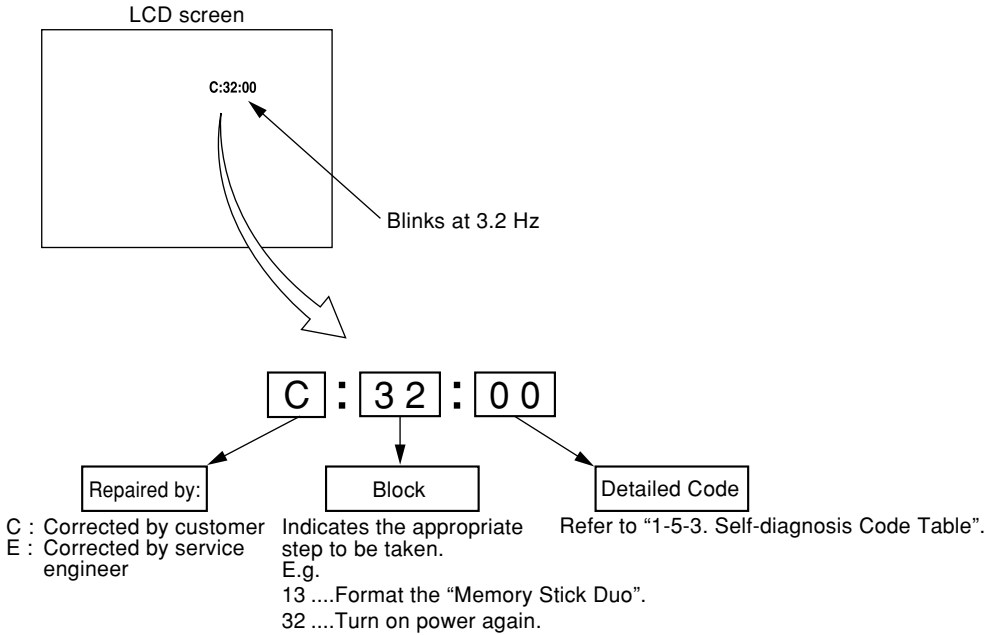

1-5-3. Self-diagnosis Code Table

Self-diagnosis Code			Symptom/State	Correction
Repaired by:	Block Function	Detailed Code		
C	1 3	0 1	The internal memory has experienced a media error.	Turn the power off and on again.
			The internal memory has experienced a format error.	Format the internal memory.
			“Memory Stick Duo” is unformatted.	Format the “Memory Stick Duo”.
			“Memory Stick Duo” is broken.	Insert a new “Memory Stick Duo”.
			“Memory Stick Duo” type error	Insert a supported “Memory Stick Duo”.
			The camera cannot read or write data on the “Memory Stick Duo”.	Turn the power off and on again, or taking out and inserting the “Memory Stick Duo” several times.
C	3 2	0 1	Trouble with hardware	Turn the power off and on again.
E	6 1	0 0	Difficult to adjust focus (Cannot initialize focus)	Retry turn the power on by the power switch. If it does not recover, check the focus reset sensor of lens block (pin ③ of CN707 on the SY-218 board). If it is OK, check the focus motor drive IC (IC401 on the SY-218 board).
E	6 1	1 0	Zoom operations fault (Cannot initialize zoom lens.)	Retry turn the power on by the power switch. Check the zoom reset sensor of lens block (pin ⑩ of CN707 on the SY-218 board), if zooming is performed when the zoom lever is operated. If it is OK, check the zoom motor drive IC (IC401 on the SY-218 board).
E	6 2	0 2	Abnormality of IC for steadyshot.	Check or replacement of the IC for steadyshot (IC401 on the SY-218 board).
E	6 2	1 0	Lens initializing failure.	Check or replacement of the IC for steadyshot (IC401 on the SY-218 board).
E	6 2	1 1	Lens overheating (PITCH).	Check the HALL element (PITCH) of optical image stabilizer (pin ⑧, ⑩ of CN708 on the SY-218 board). If it is OK, check PITCH/YAW angular velocity sensor (SE401 on the SY-218 board) peripheral circuits.
E	6 2	1 2	Lens overheating (YAW).	Check the HALL element (YAW) of optical image stabilizer (pin ⑫, ⑭ of CN708 on the SY-218 board). If it is OK, check PITCH/YAW angular velocity sensor (SE402 on the SY-218 board) peripheral circuits.
E	6 2	2 0	Abnormality of thermistor.	Check the OIS temp sensor of optical image stabilizer (pin ④ of CN707 on the SY-218 board).
E	9 1	0 1	Abnormality when flash is being charged.	Checking of flash unit or replacement of flash unit. (Note)
E	9 2	0 0	Non-standard battery is used.	Use the compatible battery only.

Note: After repair, be sure to perform “1-6. PROCESS AFTER FIXING FLASH ERROR”.

1-6. PROCESS AFTER FIXING FLASH ERROR



When “FLASH error” (Self-diagnosis Code E : 91 : 01) occurs, to prevent any abnormal situation caused by high voltage, setting of the flash is changed automatically to disabling charge and flash setting.

After fixing, this setting needs to be deactivated. Flash error code can be initialized by the operations on the HOME screen.

Method for Initializing the Flash Error Code

Initializes the setting to the default setting.

Even if you execute this function, the images are retained.

1 MENU →  (Settings) →  (Main Settings) → [Initialize] → [OK]
→ ● on the control button

Note

- Be sure not to turn off the camera while initializing.

1-1. SY-218基板交換時の注意

リストアデータ

補修用基板と交換する時、交換前の基板より調整に必要なデータを取得してください。
データの取得はAdjust StationからAdjust Manualを起動させて「Restore Data」を実行させてください。
本機で取得されるデータは下記になります。

- USB Serial No.
- Angular Velocity Sensor Sensitivity Adjustment (Dp/Dy Data)
- Wide Limit Adjustment

Note：交換前の基板よりデータが読み取れない場合は、SY-218基板とレンズを同時に交換する必要があります。

仕向けデータ

補修用基板と交換する時、補修用基板に書かれている仕向けデータは元の設定と違っている場合があります。
Adjust StationからAdjust Manualを起動させて「Destination Data Write」を実行させてください。

USBシリアルNo.

セットは、1台毎に異なる固有のID（USB Serial No.）を書き込んだ後、出荷されています。
新品の補修用基板には、このIDが書き込まれていないので、基板交換後にIDを入力する必要があります。
Adjust StationからAdjust Manualを起動させて「USB Serial No. Input」を実行させてください。

角速度センサ

補修用基板と交換する時、角速度センサ（SE401, SE402）の感度表示を書き留めてください。
Adjust StationからAdjust Manualを起動させて「Angular Velocity Sensor Sensitivity Adjustment」を実行させて書き留めたデータを入力してください。

SY-218 BOARD (SIDE B)

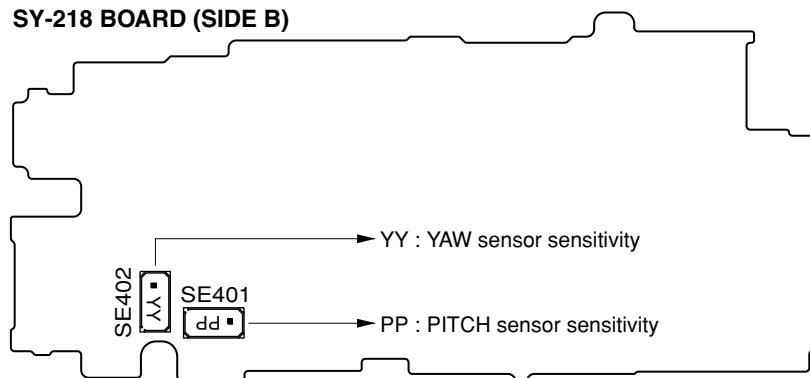

Note：SY-218基板のSE401, SE402感度表示は補修用基板にしか記載されておりません。

1-2. レンズ交換時の注意

レンズ交換時、補修用レンズ添付のW端調整データを書き留めてください。Adjust StationからAdjust Manualを起動させて「Wide Limit Adjustment」を実行させて書き留めたデータを入力してください。

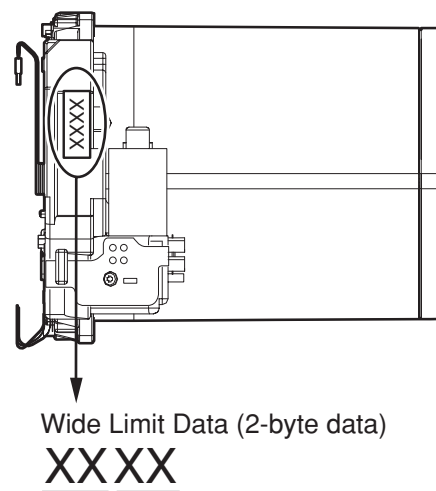

Note：W端調整データは、補修用部品にのみ記載されています。

1-3. 内蔵メモリーのデータコピーおよび消去方法

内蔵メモリーのデータコピーまたは消去はホーム画面の操作から実行可能です。（消去する場合は内蔵メモリーの初期化を行います。）



Note 1：SY-218基板交換の際は、基板交換前に内蔵メモリーのデータを消去して下さい。

Note 2：SY-218基板交換の際は、基板交換後に内蔵メモリーのフォーマットおよび初期化を実行して下さい。

内蔵メモリーのコピー方法

内蔵メモリーに記録した画像を、“メモリースティック デュオ”に一括コピーします。

1 十分な空き容量のある“メモリースティック デュオ”を本機に入れる

2 MENU →  (設定) →  (“メモリースティック”ツール) → [コピー]
→ [実行] → コントロールボタン中央の●



ご注意

- 十分に充電したバッテリーをご使用ください。残量の少ないバッテリーを使用して画像ファイルをコピーすると、バッテリー切れのためデータを転送できなかったり、データを破損するおそれがあります。
- 画像ごとのコピーはできません。
- データをコピーしても、内蔵メモリー内のデータは削除されません。内蔵メモリーの内容を消去するには、コピー後に“メモリースティック デュオ”を本体から取りはずし、[内蔵メモリーツール]の[フォーマット]を行ってください。
- データをコピーすると“メモリースティック デュオ”内に新しいフォルダが作成されます。コピー先のフォルダを指定することはできません。

内蔵メモリーのフォーマット方法

“メモリースティック デュオ”または内蔵メモリーをフォーマット(初期化)します。

市販の“メモリースティック デュオ”はフォーマット済みのため、フォーマットの必要はありません。

1 MENU →  (設定) →  (“メモリースティック”ツール)または (内蔵メモリーツール) → [フォーマット] → [実行] → コントロールボタン中央の●

ご注意

- フォーマットすると、プロテクトしてある画像も含めて、すべてのデータが消去され、元に戻せません。

1-4. 内蔵メモリーヘータを書き戻す方法

通常は、PCからカメラの内蔵メモリーヘータを書き込むことはできない設定になっています。基板交換後などに、内蔵メモリーヘータを書き戻す場合には、この設定を一時的に変更する必要があります。設定の変更は、Adjust StationからAdjust Manualを起動させて書き込み許可ツール（Write Enable Tool）を使用します。

書き戻し方法

- 1) Adjust StationからAdjust Manualを起動する。
- 2) （Write Enable Tool）ボタンをクリックする。
- 3) “Active Write Enable Mode” ボタンをクリックする。



- 4) 設定の変更が終了すると、次のメッセージが表示されます。



- 5) ドライバを元に戻して、カメラとPCをマスタストレージ接続する。
- 6) PCに読み出しておいたデータをカメラの内蔵メモリーに書き込む。
- 7) カメラとPCの接続を解除し、カメラの電源をOFFにする。

Note：カメラの電源をOFFにすることにより、書き込み許可の設定が解除されます。

1-5. 自己診断機能

1-5-1. 自己診断機能について

本機の動作に不具合が生じたとき、自己診断機能が働き、LCD画面に、どう処置したらよいか判断できる表示を行います。自己診断機能については取扱説明書にも掲載されています。

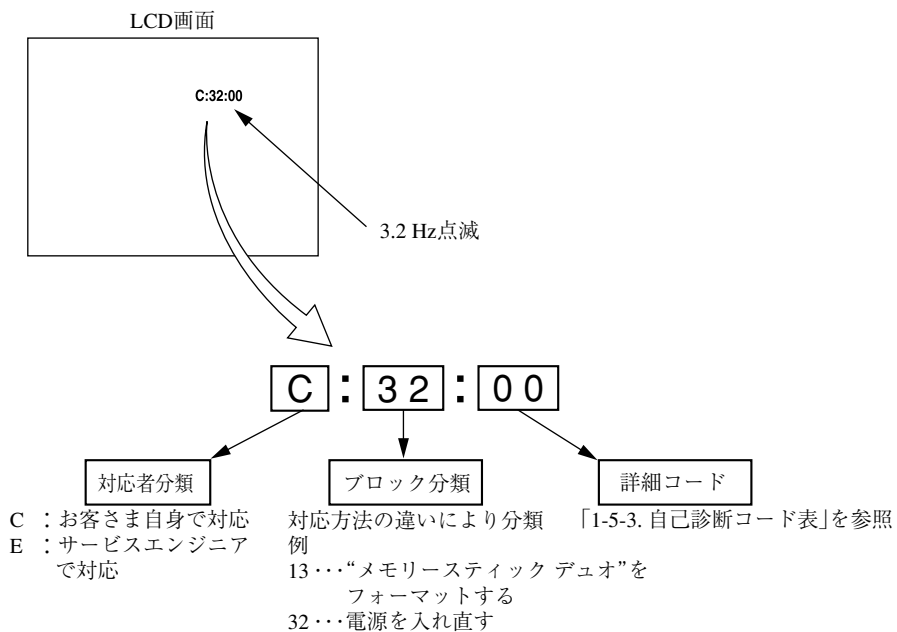

1-5-2. 自己診断表示

本機の動作に不具合が生じたとき、LCD画面にアルファベットと4桁の数字が表示され、3.2 Hzで点滅します。この5文字の表示によって対応者分類および不具合の生じたブロックの分類、不具合の詳細コードを示します。

1-5-3. 自己診断コード表

自己診断コード			症状/状態	対応/方法
対応者	ブロック機能	詳細コード		
C	1 3	0 1	内蔵メモリーにメディアエラーがあった	電源を入れ直す。
			内蔵メモリーにフォーマットエラーがあった	内蔵メモリーをフォーマットする。
			フォーマットしていない“メモリースティック デュオ”を入れた	“メモリースティック デュオ”をフォーマットする。
			“メモリースティック デュオ”が壊れている	新しい“メモリースティック デュオ”に交換する。
			“メモリースティック デュオ”のタイプエラーを検出した	規格内の“メモリースティック デュオ”を挿入する。
			“メモリースティック デュオ”が読み/書きできない	電源の入れ直し、または“メモリースティック デュオ”の挿し/外しを数回試す。
C	3 2	0 1	ハードウェアトラブルを検出した	電源を入れ直す。
E	6 1	0 0	フォーカスが合いにくい (フォーカスの初期化ができない)	操作スイッチの電源を入れ直す。 復帰しない場合はレンズブロックのフォーカスリセットセンサ (SY-218基板CN707 ③ピン) を点検する。異常なければフォーカスマータ駆動IC (SY-218基板IC401) を点検する。
E	6 1	1 0	ズーム動作の異常 (ズームレンズの初期化ができない)	操作スイッチの電源を入れ直す。 ズームレバーを操作したときにズーム動作をすればレンズブロックのズームリセットセンサ (SY-218基板CN707 ⑩ピン) を点検する。異常なければズームモータ駆動IC (SY-218基板IC401) を点検する。
E	6 2	0 2	手振れ補正用ICの異常	手振れ補正用IC (SY-218基板IC401) を点検または交換する。
E	6 2	1 0	手振れ補正用ICの異常 (レンズ初期化異常)	手振れ補正用IC (SY-218基板IC401) を点検または交換する。
E	6 2	1 1	レンズオーバーヒート (PITCH)	光学手振れ補正ブロックのホール素子 (PITCH) (SY-218基板CN708 ⑧, ⑩ピン) を点検する。異常なければPITCH/YAW角速度センサ (SY-218基板SE401) 周辺の回路を点検する。
E	6 2	1 2	レンズオーバーヒート (YAW)	光学手振れ補正ブロックのホール素子 (YAW) (SY-218基板CN708 ⑫, ⑭ピン) を点検する。異常なければPITCH/YAW角速度センサ (SY-218基板SE402) 周辺の回路を点検する。
E	6 2	2 0	サーミスタの異常	光学手振れ補正ブロックのサーミスタ (SY-218基板CN707 ④ピン) を点検する。
E	9 1	0 1	フラッシュの充電異常	フラッシュユニットを点検または交換する。(Note)
E	9 2	0 0	規定外の充電電池が使用された	規定の充電電池を使用する。

Note : 交換後は、必ず「1-6. フラッシュエラー発生時の対処法」を行って下さい。

1-6. フラッシュエラー発生時の対処法

本機はフラッシュエラー（自己診断コードE：91：01）が発生した場合、高電圧による異常を防止するために自動的にフラッシュ充電および発光禁止の設定になります。
フラッシュエラー発生後はエラーの解除を行う必要があります。エラーの解除はホーム画面から初期化操作を実行することにより行います。

お買い上げ時の設定に戻します。

[設定リセット]を実行しても、画像は削除されません。

1 MENU →  (設定) →  (本体設定) → [設定リセット] → [実行]
→ コントロールボタン中央の●で決定

ご注意

- 設定リセット中は電源が切れないようにご注意ください。

2. DISASSEMBLY

NOTE FOR REPAIR

- Make sure that the flat cable and flexible board are not cracked or bent at the terminal.
Do not insert the cable insufficiently nor crookedly.
- When remove a connector, don't pull at wire of connector. It is possible that a wire is snapped.
- When installing a connector, don't press down at wire of connector.
It is possible that a wire is snapped.
- Do not apply excessive load to the gilded flexible board.

Cut and remove the part of gilt which comes off at the point.
(Be careful or some pieces of gilt may be left inside)

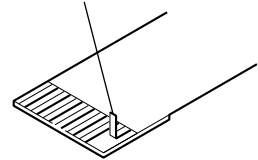

DISCHARGING OF THE CHARGING CAPACITOR (C901)

The charging capacitors (C901) are charged up to the maximum 300 V potential.

There is a danger of electric shock by this high voltage when the capacitor is handled by hand. The electric shock is caused by the charged voltage which is kept without discharging when the main power of the unit is simply turned off. Therefore, the remaining voltage must be discharged as described below.

Preparing the Short Jig

To preparing the short jig, a small clip is attached to each end of a resistor of 1 k Ω / 1 W (1-215-869-11).

Wrap insulating tape fully around the leads of the resistor to prevent electrical shock.

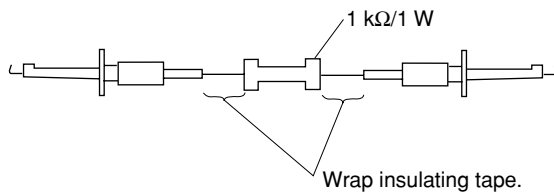

Note: High-voltage cautions

Discharging the Capacitor

Short-circuit between the two points with the short jig about 10 seconds.

R: 1 k Ω / 1 W
(Part code: 1-215-869-11)

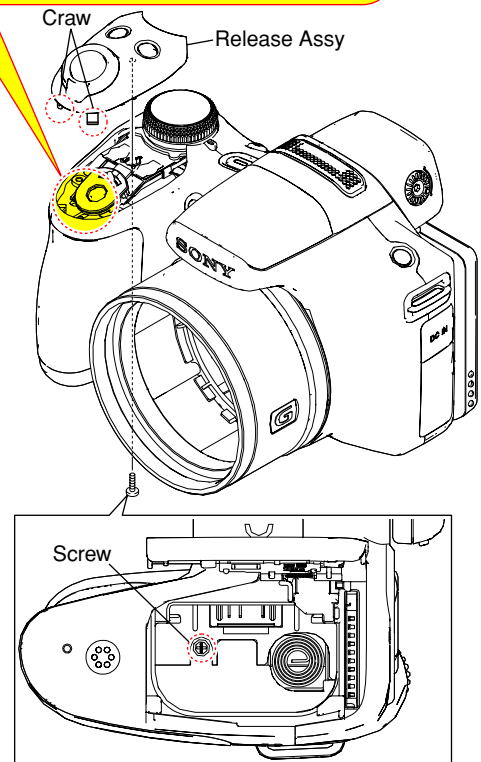
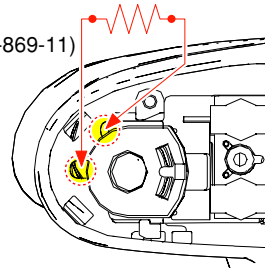

2-1. IDENTIFYING PARTS

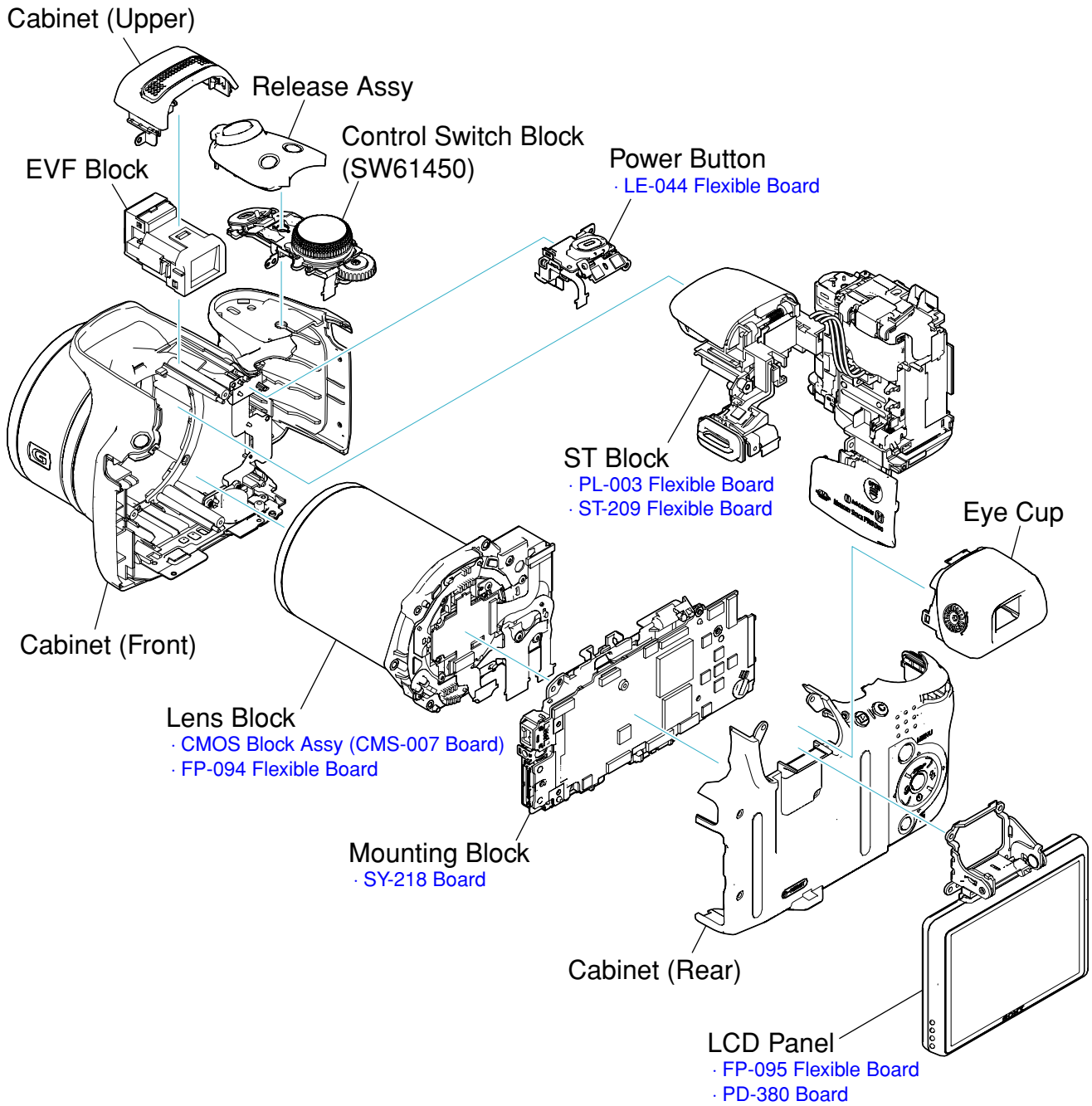

- DISASSEMBLY FLOW -

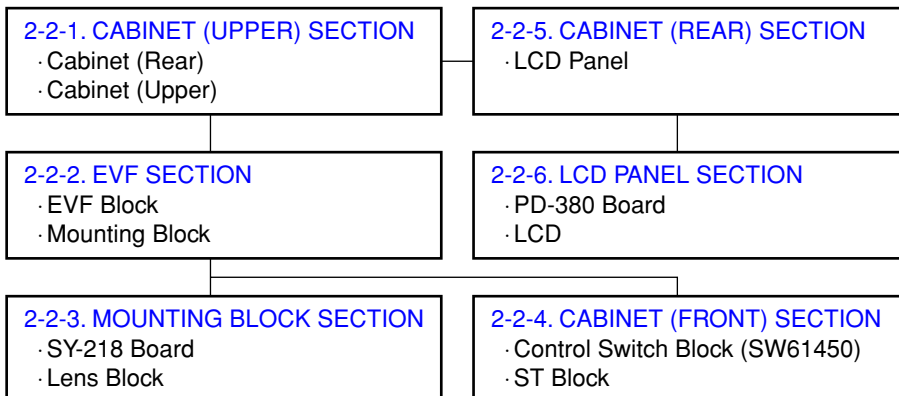

2-2. DISASSEMBLY

EXPLODED VIEW

HARDWARE LIST

2-2-1. CABINET (UPPER) SECTION

Follow the disassembly in the numerical order given.

- ① Cabinet (Rear) (①-1 to ①-9)
- ② Cabinet (Upper) (②-1 to ②-2)

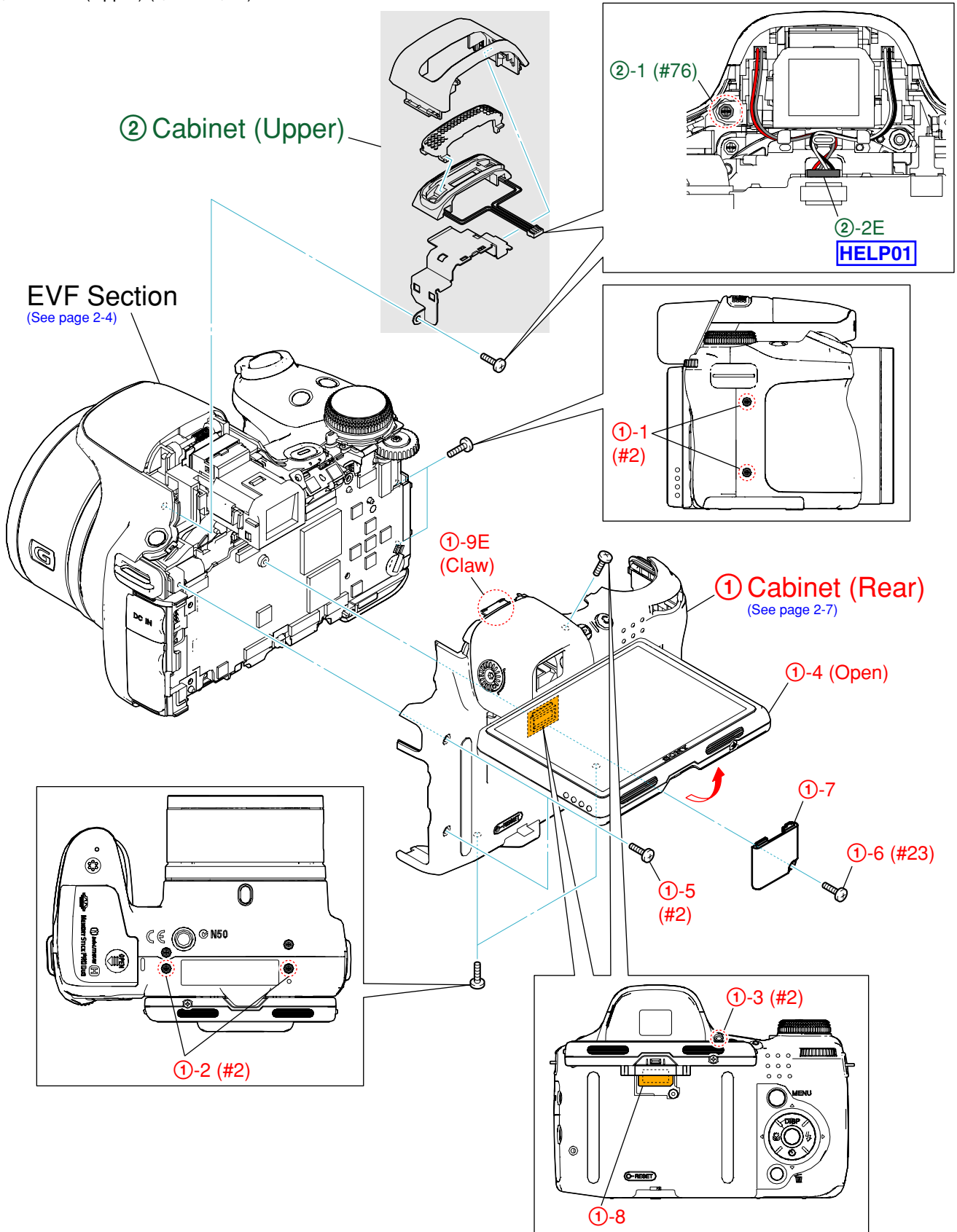

2-2-2. EVF SECTION

Follow the disassembly in the numerical order given.

- ① EVF Block (①-1 to ①-3)
- ② Mounting Block (②-1 to ②-11)

EXPLODED VIEW

HARDWARE LIST

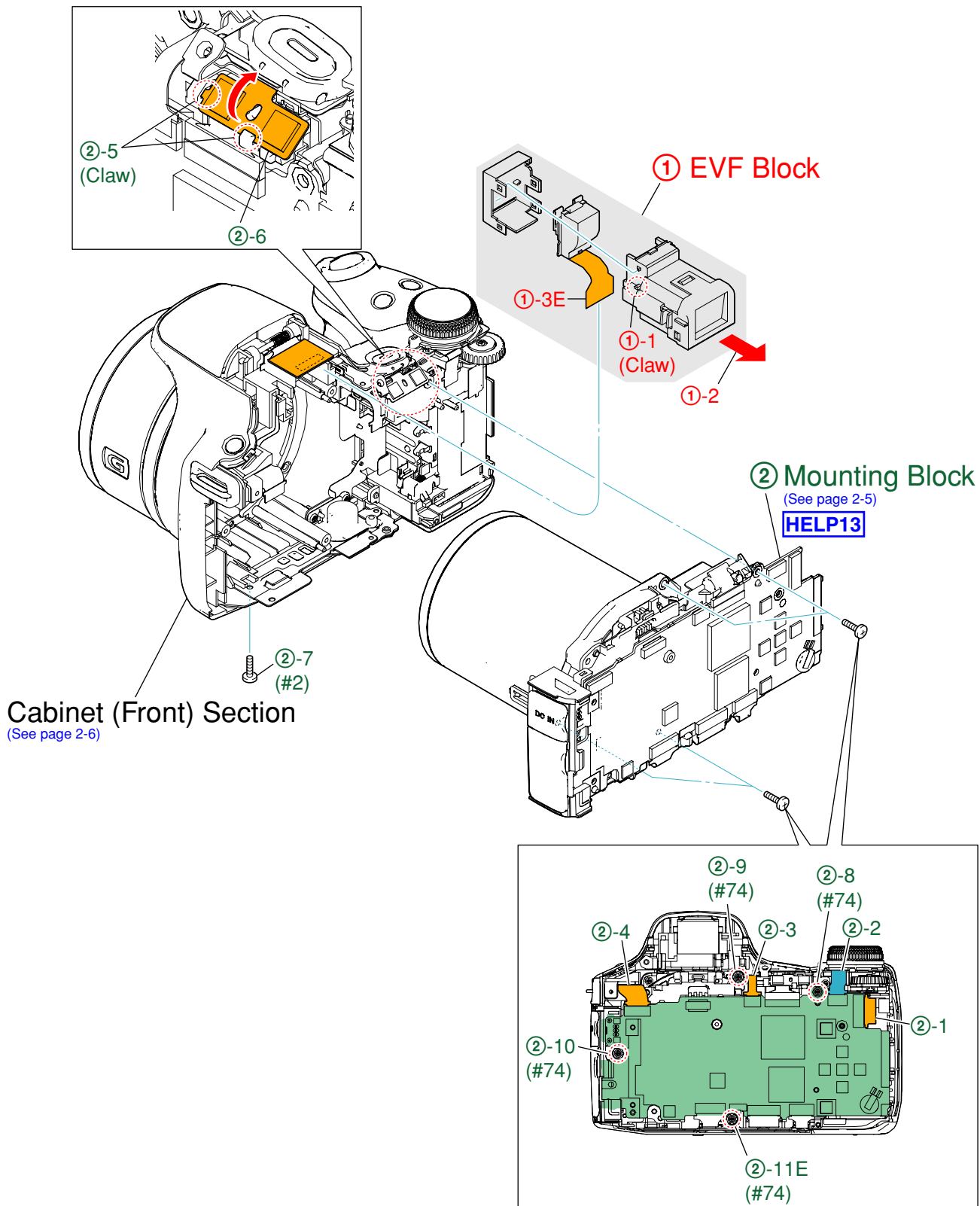

2-2-3. MOUNTING BLOCK SECTION

Follow the disassembly in the numerical order given.

- ① SY-218 Board (①-1 to ①-12)
- ② Lens Block (②-1 to ②-2)

EXPLODED VIEW

HARDWARE LIST

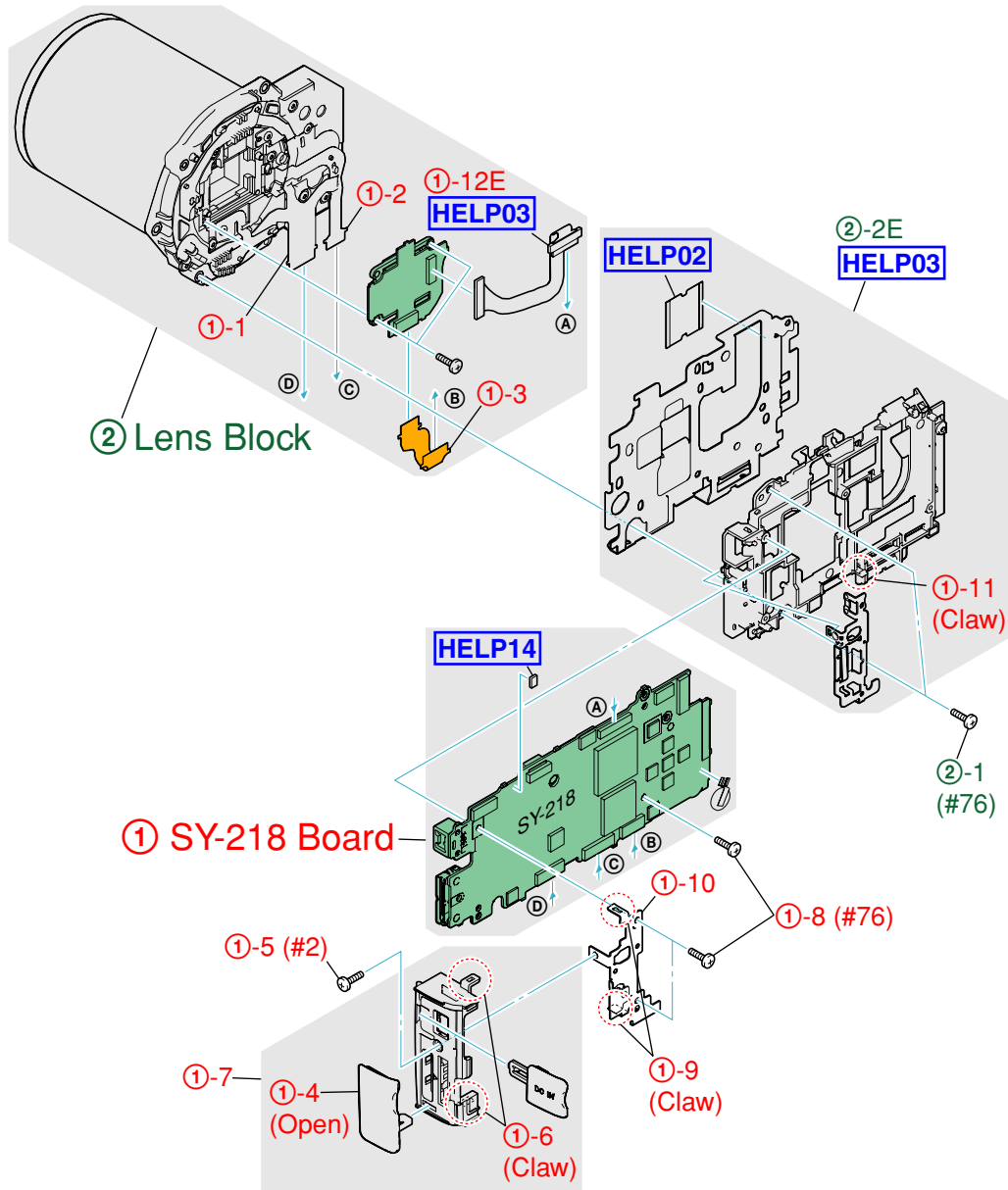

2-2-4. CABINET (FRONT) SECTION

Follow the disassembly in the numerical order given.

- ① Control Switch Block (SW61450) (①-1 to ①-7)
- ② ST Block (②-1 to ②-3)

EXPLODED VIEW

HARDWARE LIST

Note: High-voltage cautions

Discharging the Capacitor

Short-circuit between the two points with the short jig about 10 seconds.

R:1 kΩ/1 W
(Part code: 1-215-869-11)

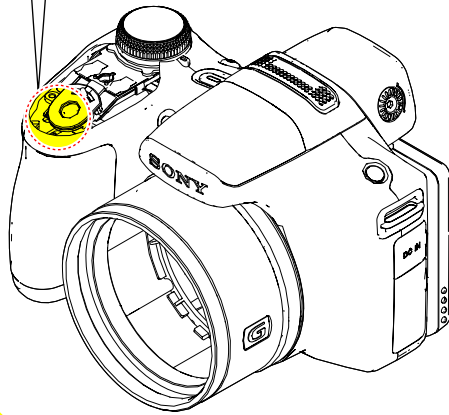
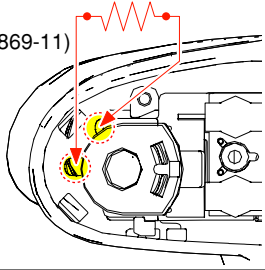

① Control Switch Block (SW61450)

①-4
HELP04

①-3 (Claw)

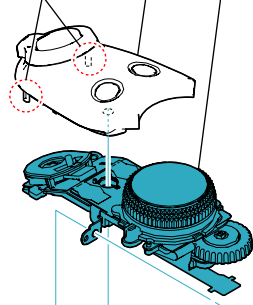

①-7E
HELP11

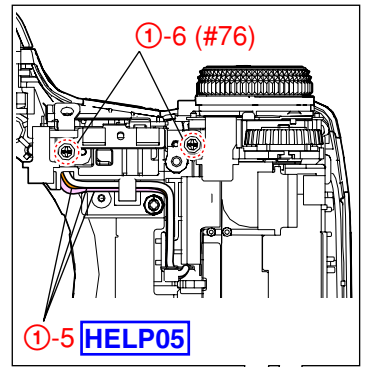

①-5
HELP05

② ST Block

HELP05
HELP12

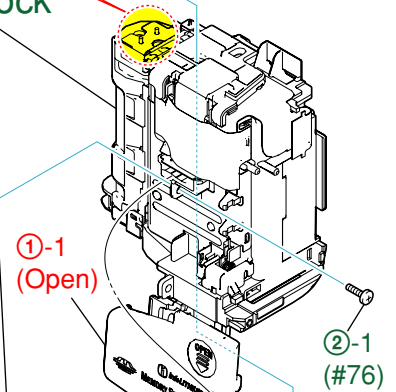

①-1 (Open)

②-1 (#76)

①-2 (#74)

②-3E

②-2 (#76)

2-2-6. LCD PANEL SECTION

Follow the disassembly in the numerical order given.

- ① PD-380 Board (①-1 to ①-15)
- ① LCD (②-1 to ②-3)

EXPLODED VIEW

HARDWARE LIST

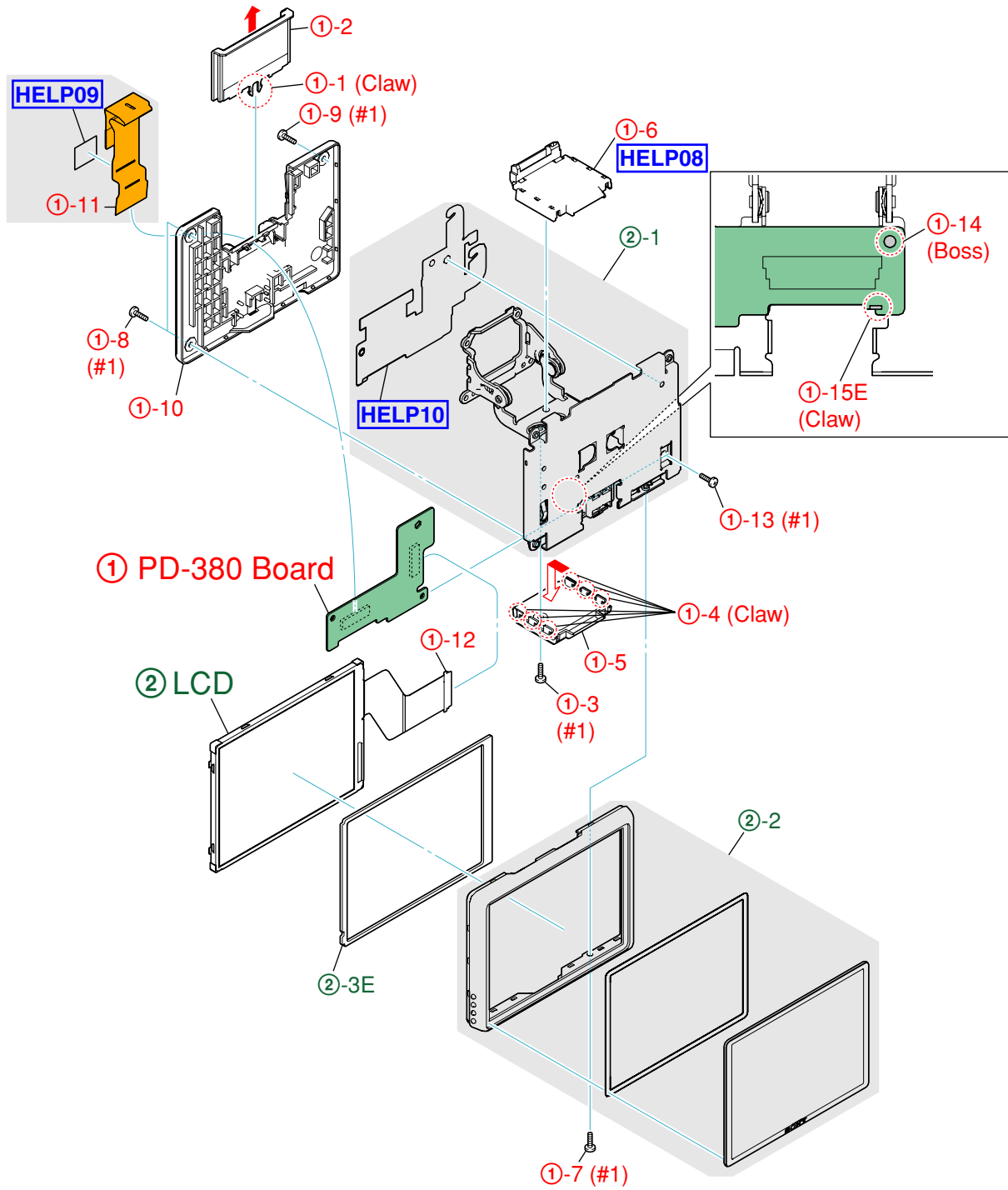

HELP

Sheet attachment positions and procedures of processing the flexible boards/harnesses are shown.

HELP01: Microphone Harness

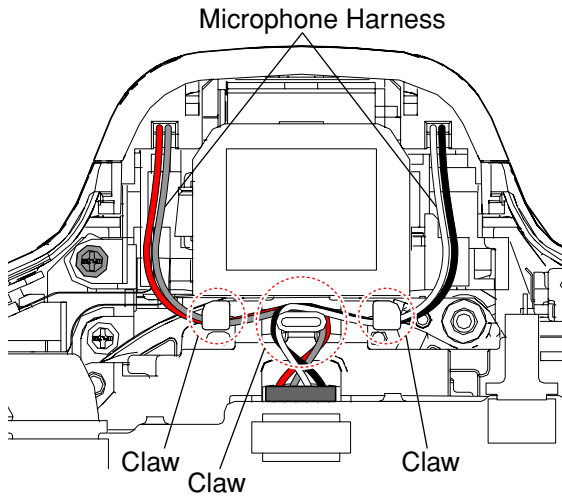

HELP03: Lens Flexible Board/Harness (HN-084)

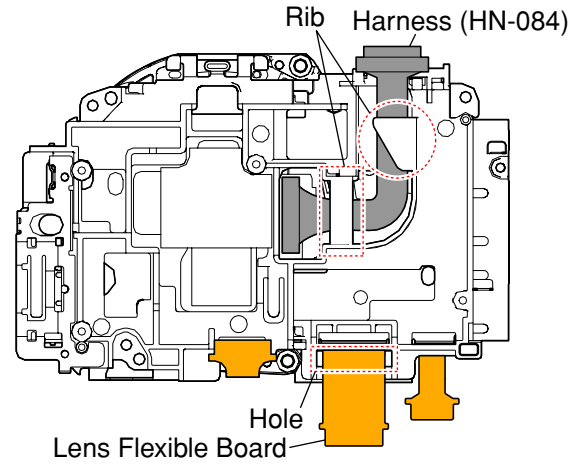

HELP02: Sheet (Lens Holder)

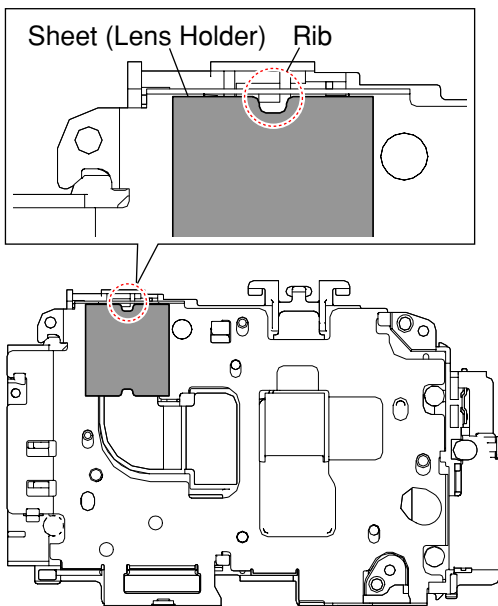

HELP04: Release Assy

Adjust the lever of control switch block (SW61450) to the position of the center.

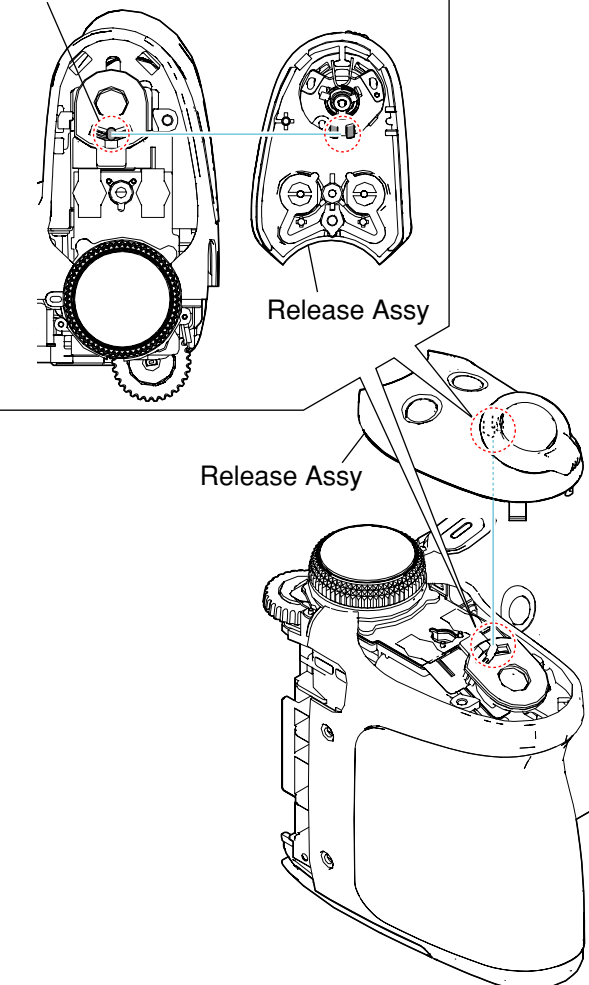

HELP05: Flash Unit Harness

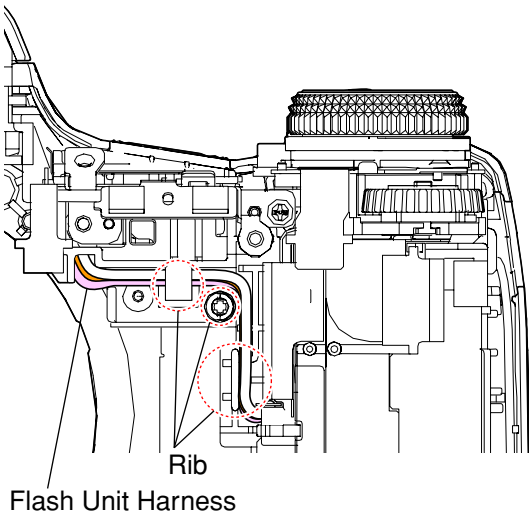

HELP06: Eye Cup Assy

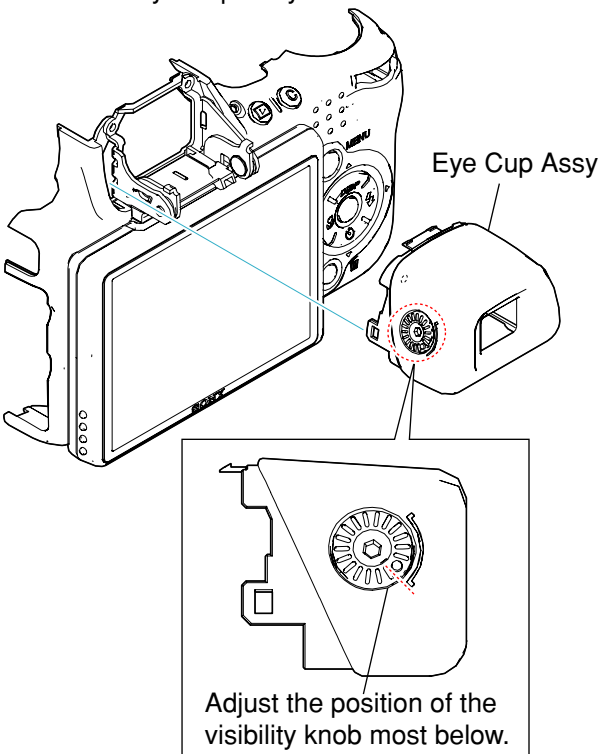

HELP07: FP-095 Flexible Board

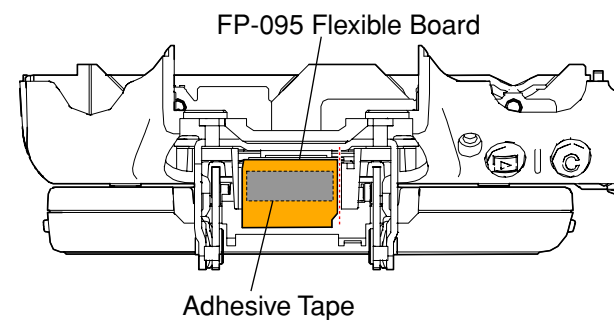

HELP08: Hinge Cover (M) Assy Spring

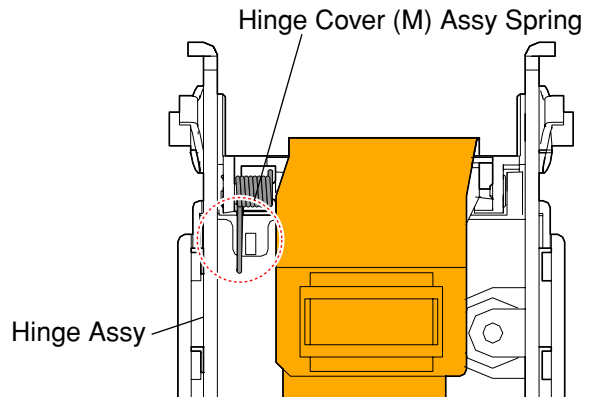

HELP09: Flexible Slider Sheet

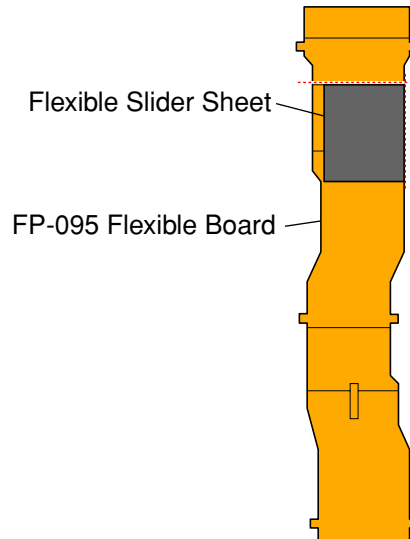

HELP10: CK Insulating Sheet

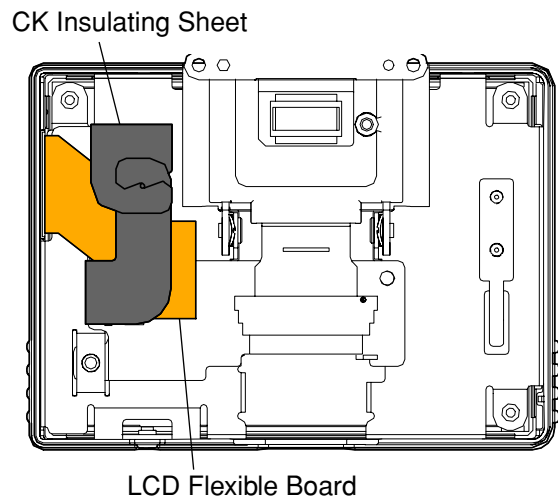

HELP11: Assembling Method of Power Button Block

① Install the ground plate (power) to the AF retainer.

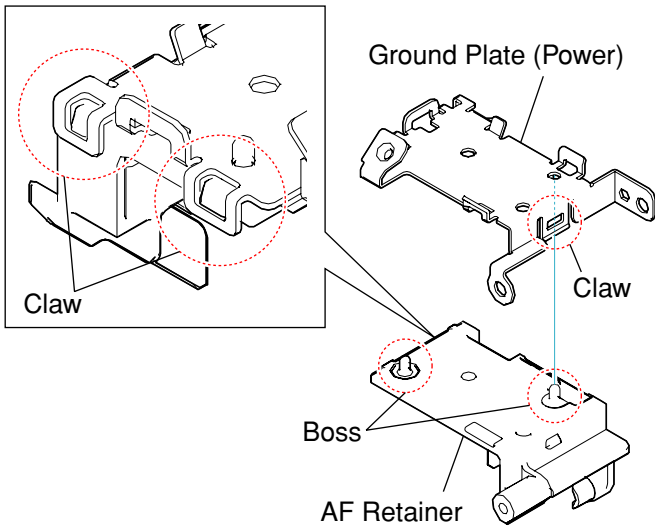

③ Fix the power button assy on LE-044 flexible board.

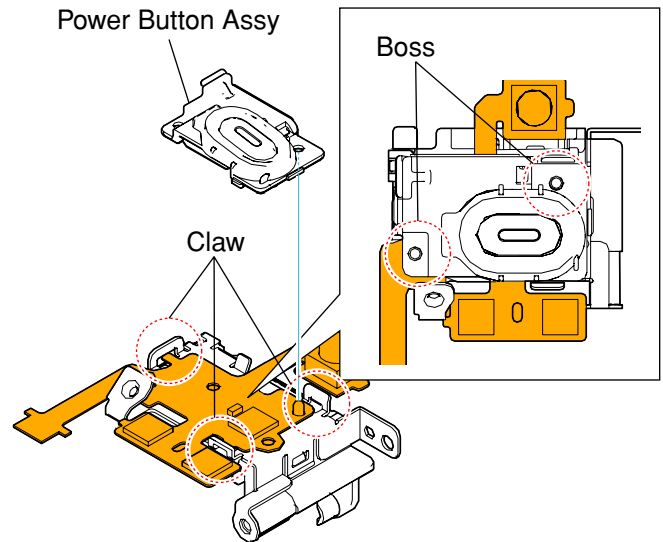

② Fix the LE-044 flexible board on the ground plate (power).

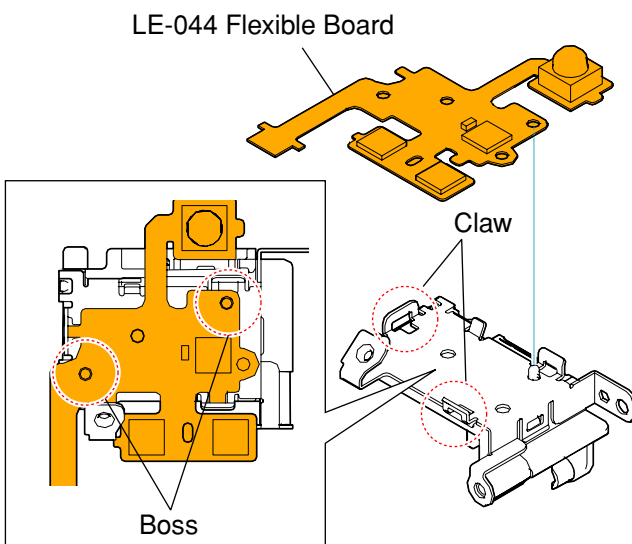

④ Bend the AF part of the LE-044 flexible board, and fix by the claws.

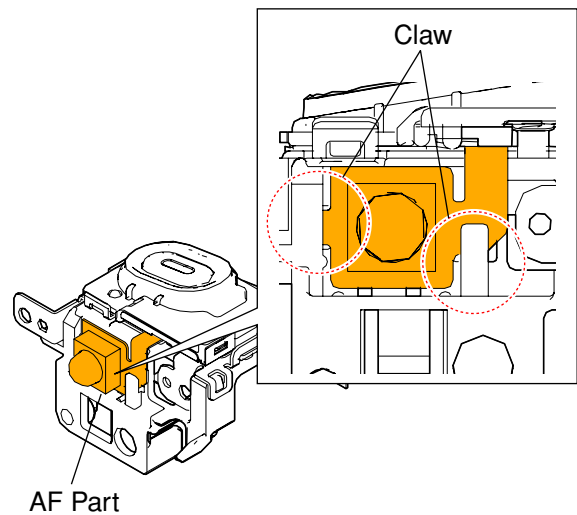

HELP12: Assembling Method of ST Block

- ① Insert the harness of flash unit in the ST base assy.
- ② Arrange the harness to the space in the back.
Note: Process it from upper side in white, orange and pink.
- ③ Set the flash unit in the ST base assy.

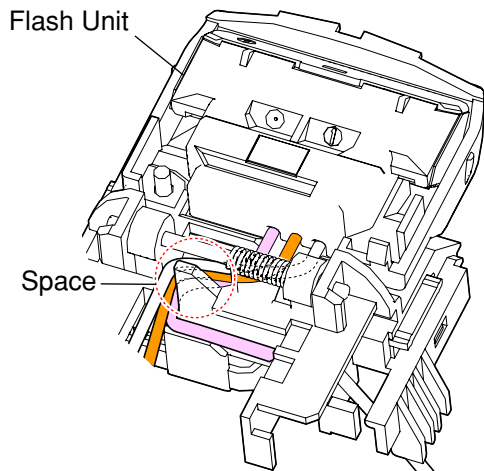

- ⑥ Arrange the harness to the space.
Note: Arrange it from upper side in white, orange and pink.
- ⑦ Arrange the harness to slits in the bottom.
Note: Arrange it from this side in white, orange and pink.

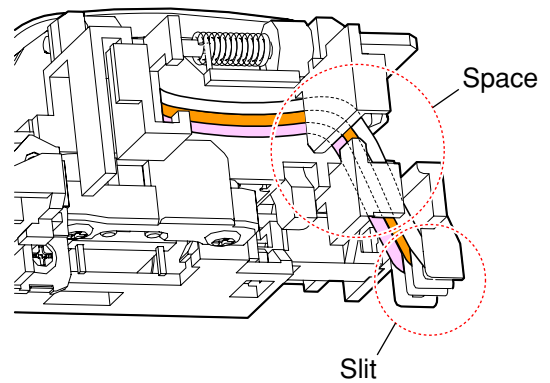

- ④ Attach the ST cover to the ST base assy.

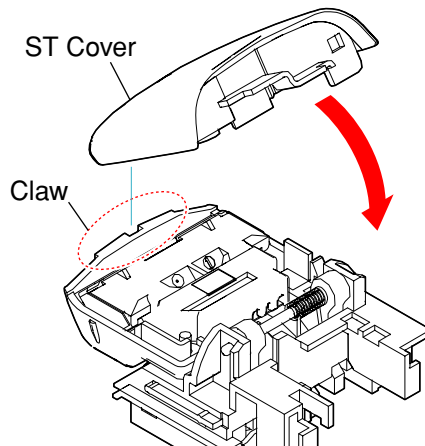

- ⑧ Insert the plunger of the PL-003 flexible board in the PL holder from the direction of the arrow of figure.
- ⑨ Fix the PL-003 flexible board by claws.

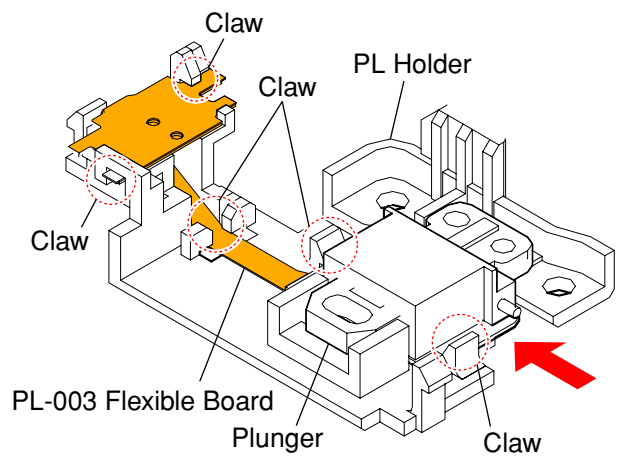

- ⑤ Tighten up a screw.

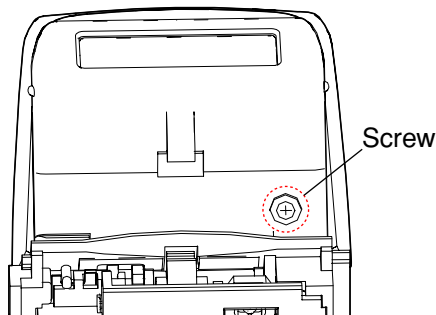

- ⑩ Attach the PL holder to the ST base assy.
- ⑪ Tighten up two screws.

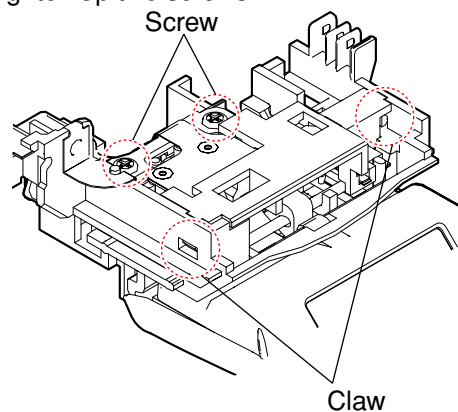

⑫ Arrange the PL-003 flexible board as shown in the figure.

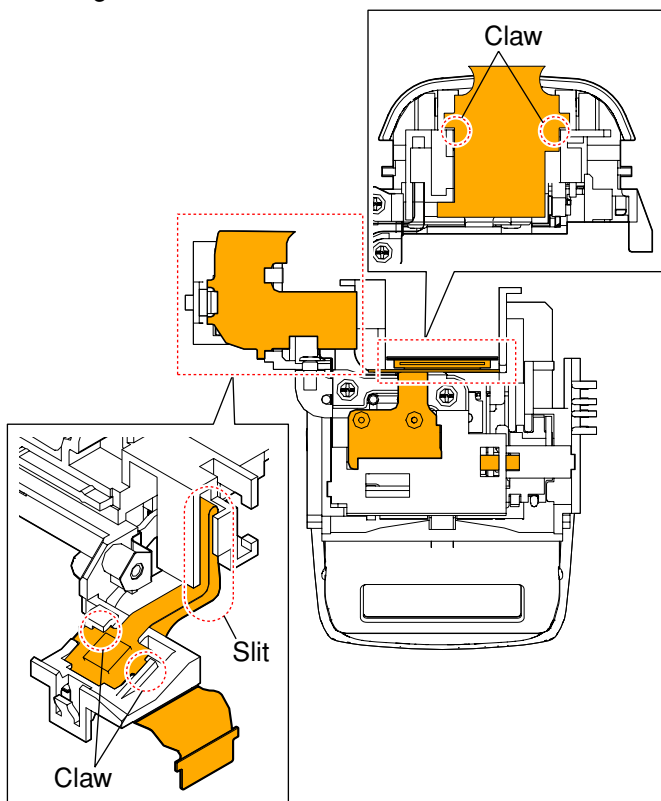

⑬ Attach the strap sheet metal (R) to the ST base assy.

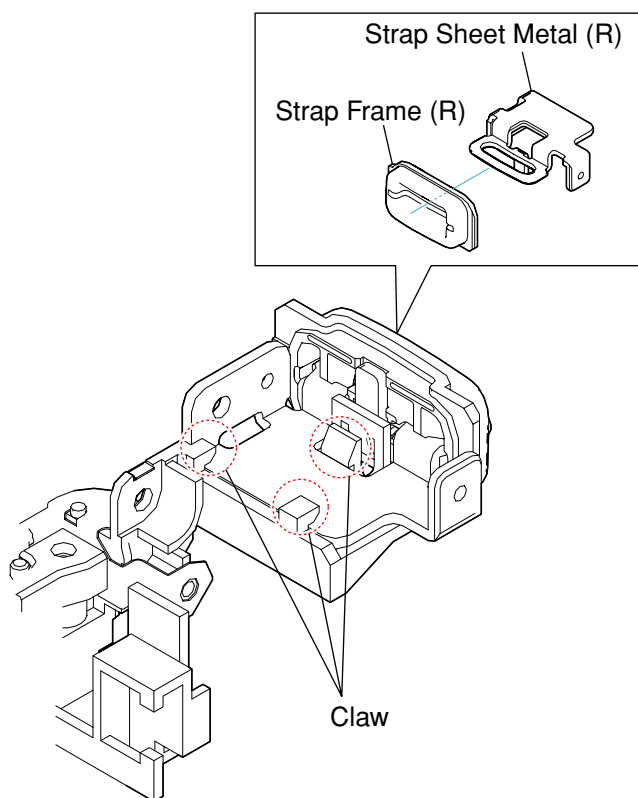

⑭ Arrange the PL-003 flexible board as shown in the figure.

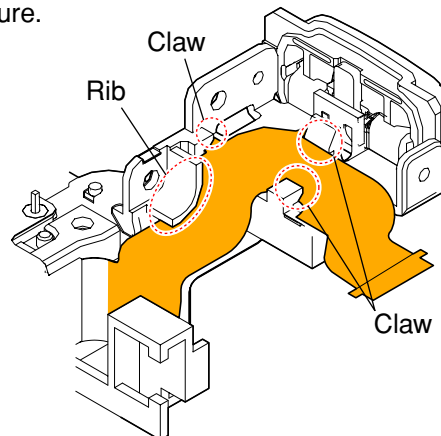

⑮ Insert the capacitor in the BT holder assy.
Note: Match the position of electrodes.

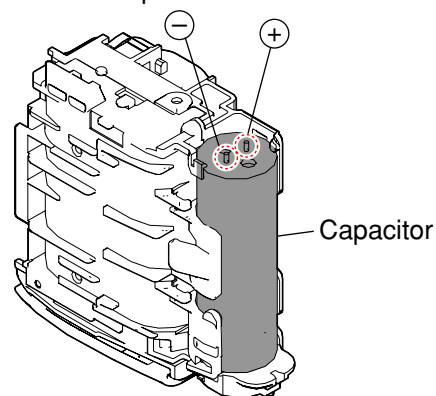

⑯ Insert the speaker in the BT holder assy.

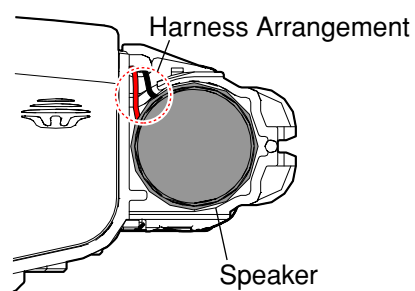

⑰ Insert the SP cover on the BT holder assy.

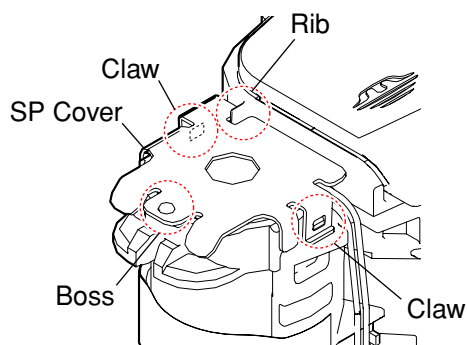

18 Arrange the speaker harness as shown in the figure.

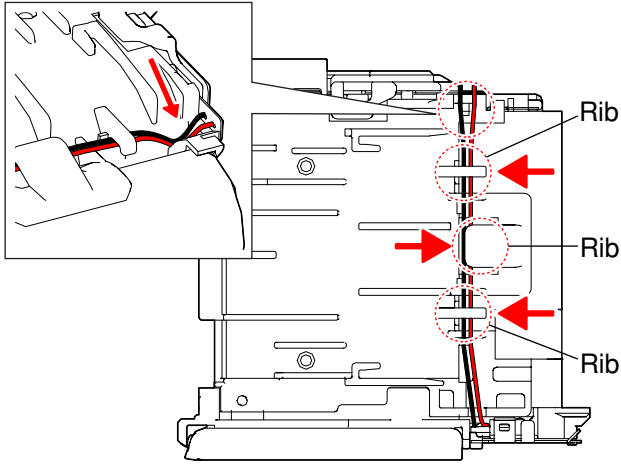

19 Insert the battery terminal board in the BT holder Assy.

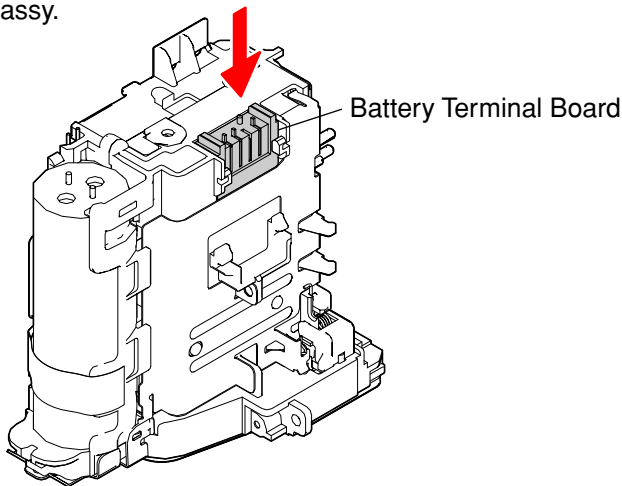

21 Attach the BT terminal cover on the BT holder Assy.

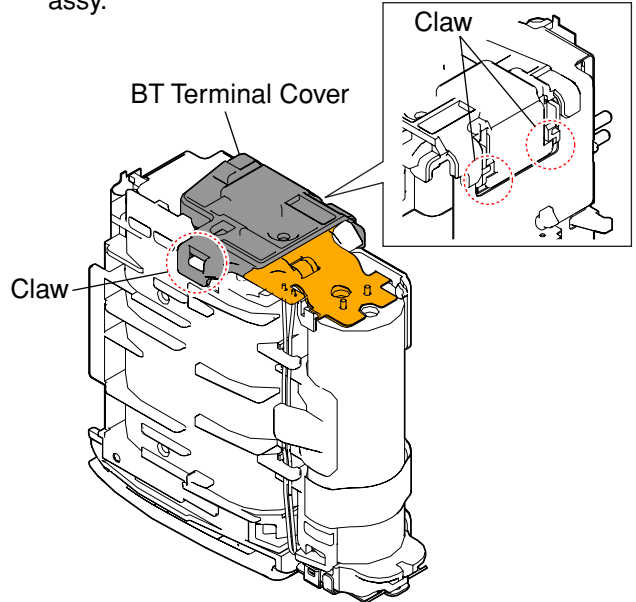

22 Arrange the ST-209 flexible board as shown in the figure.

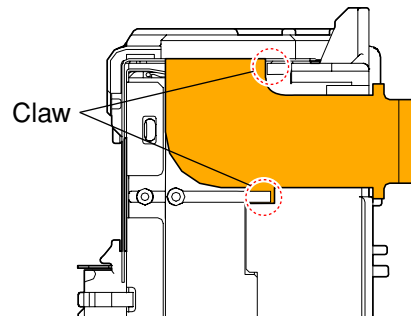

20 Insert the ST-209 flexible board on the BT holder Assy.

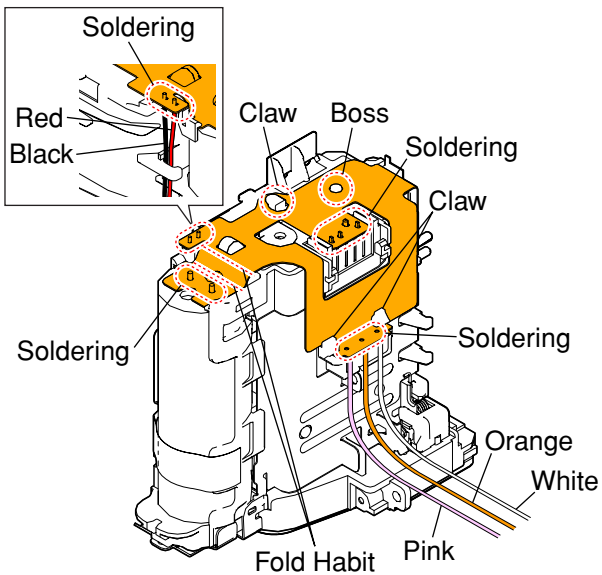

23 Paste the sheet (ST flexible)

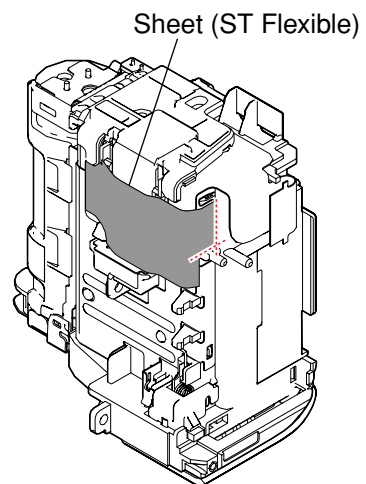

HELP13: Position of Installation of Mounting Block

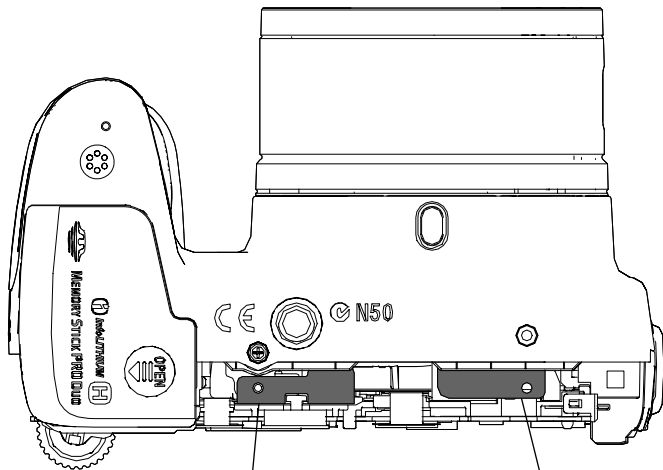

SY Heat Sink is this side. Front Cabinet Ground Plate is this side.

HELP14: Gasket (RE)

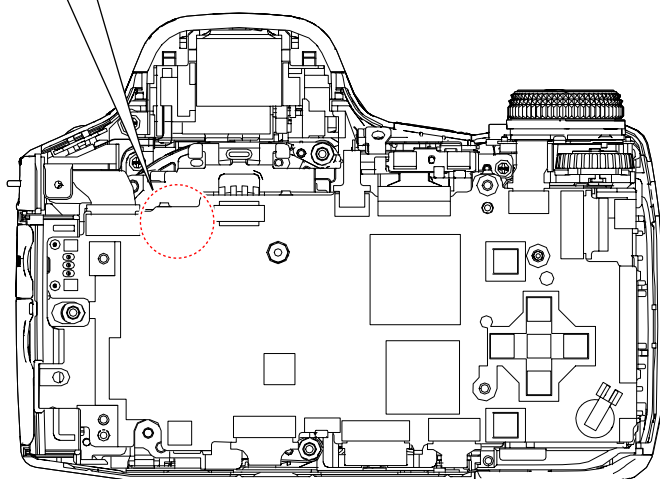
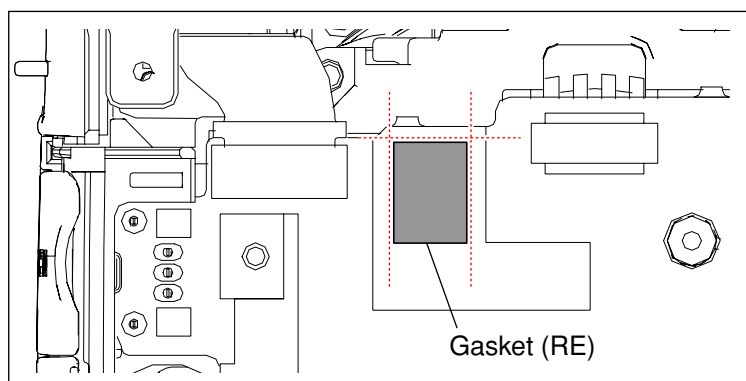

3. BLOCK DIAGRAMS

Link

• [OVERALL BLOCK DIAGRAM \(1/3\)](#)

• [POWER BLOCK DIAGRAM \(1/2\)](#)

• [OVERALL BLOCK DIAGRAM \(2/3\)](#)

• [POWER BLOCK DIAGRAM \(2/2\)](#)

• [OVERALL BLOCK DIAGRAM \(3/3\)](#)

3-2. OVERALL BLOCK DIAGRAM (2/3) () : Number in parenthesis () indicates the division number of schematic diagram where the component is located.

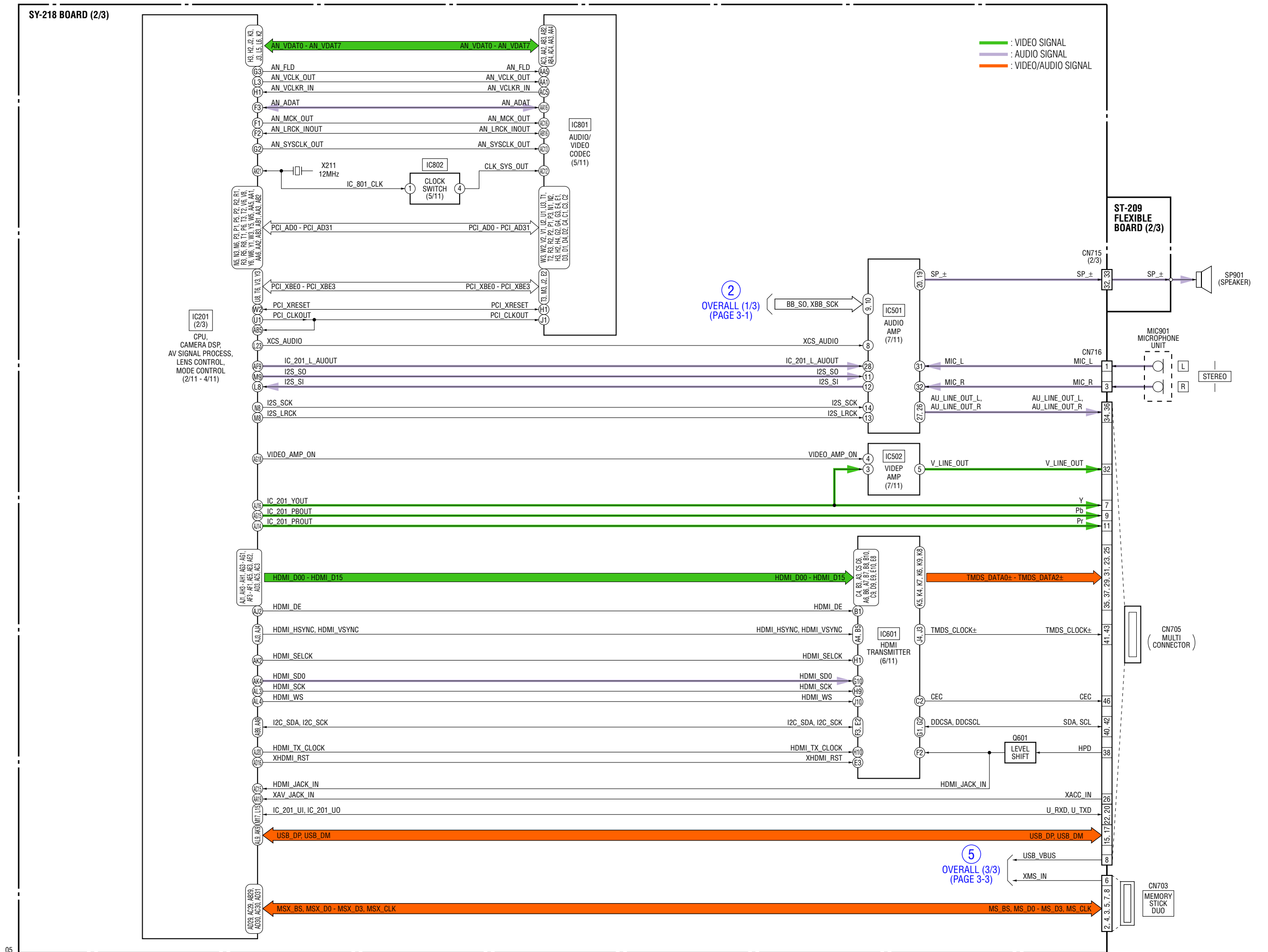

(): Number in parenthesis () indicates the division number of schematic diagram where the component is located.

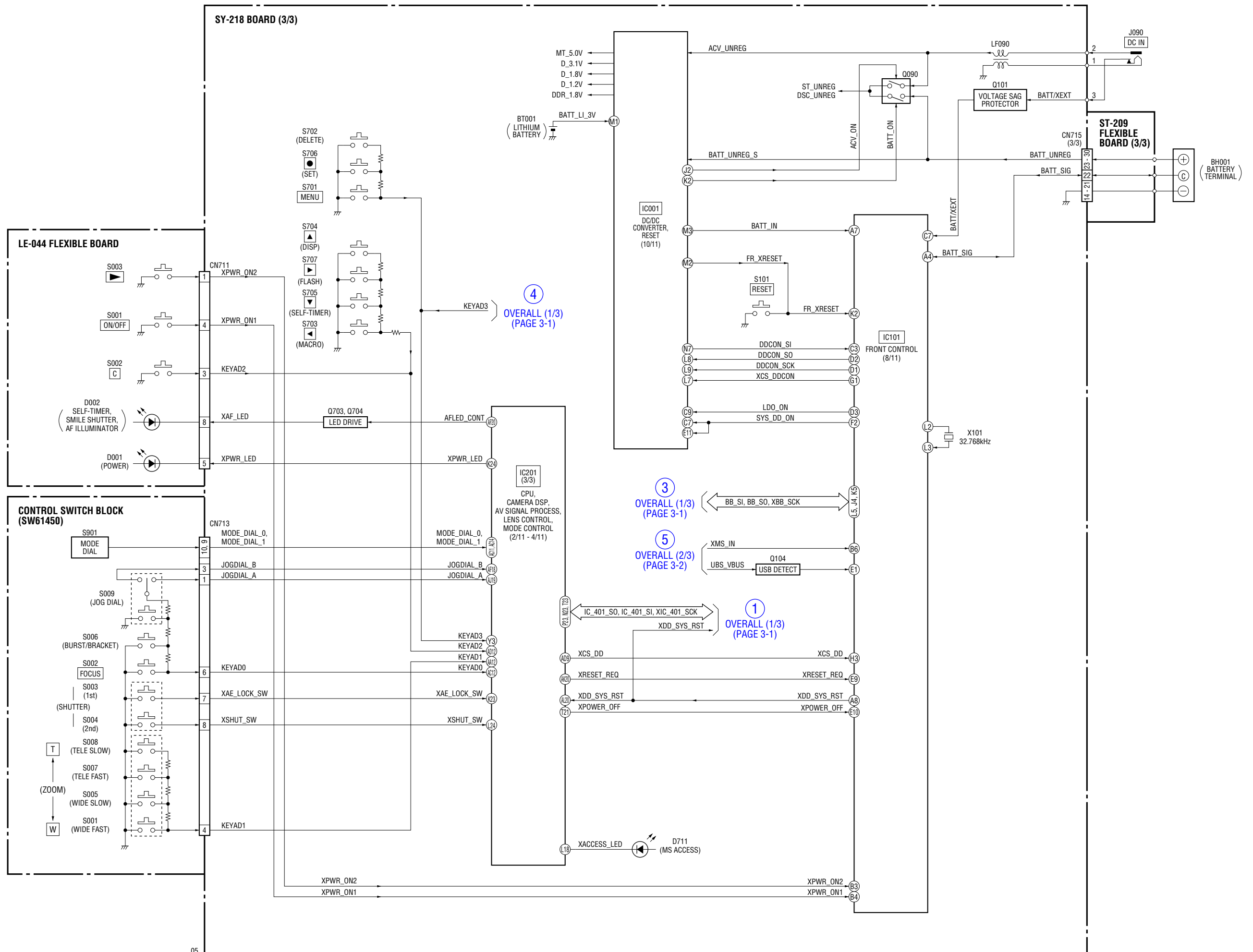

3-5. POWER BLOCK DIAGRAM (2/2) () : Number in parenthesis () indicates the division number of schematic diagram where the component is located.

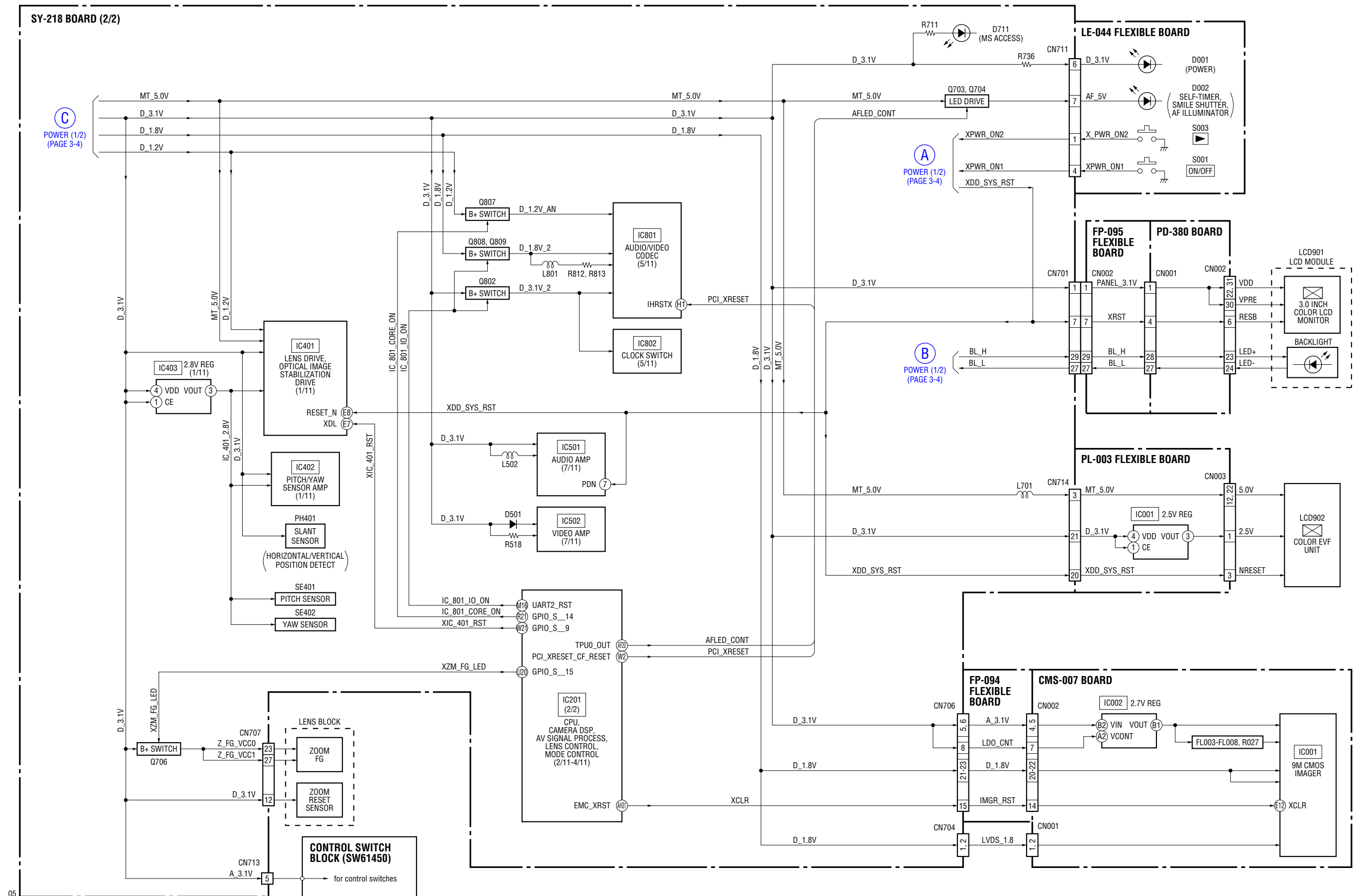

4. PRINTED WIRING BOARDS AND SCHEMATIC DIAGRAMS

4-1. FRAME SCHEMATIC DIAGRAM

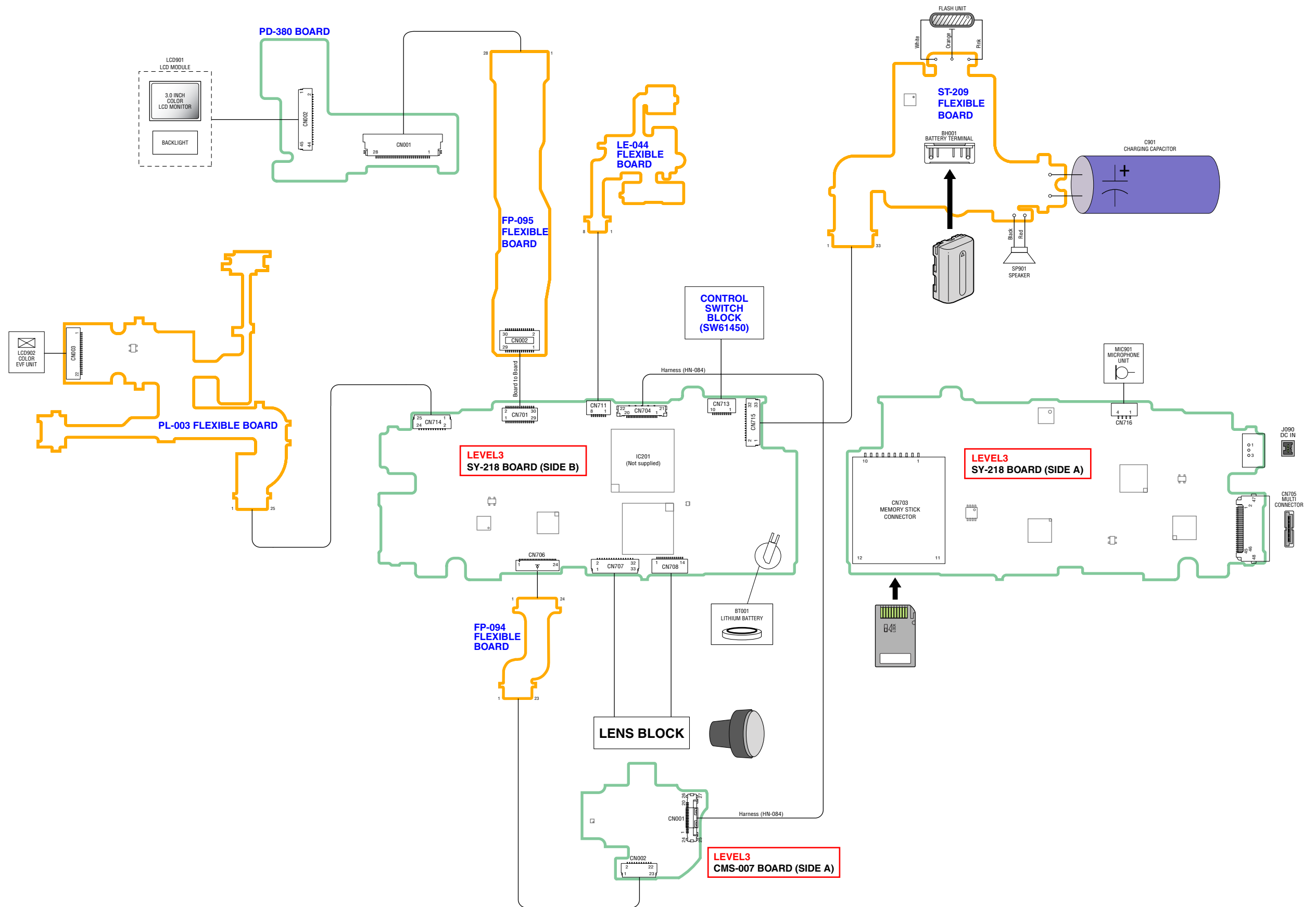

4-2. SCHEMATIC DIAGRAMS

Link

<ul style="list-style-type: none">• PD-380 BOARD (LCD CONNECTOR)	<ul style="list-style-type: none">• FP-094 FLEXIBLE BOARD (SY-CMS CONNECTION)
<ul style="list-style-type: none">• PL-003 FLEXIBLE BOARD (EVF CONNECTOR)	<ul style="list-style-type: none">• FP-095 FLEXIBLE BOARD (SY-PD CONNECTION)
<ul style="list-style-type: none">• LE-044 FLEXIBLE BOARD (AF ILLUMINATOR, CONTROL SWITCH)	<ul style="list-style-type: none">• CONTROL SWITCH BLOCK (SW61450)
<ul style="list-style-type: none">• ST-209 FLEXIBLE BOARD (FLASH DRIVE)	

<ul style="list-style-type: none">• COMMON NOTE FOR SCHEMATIC DIAGRAMS
--

(JAPANESE)

回路図共通ノート

(他に必要なノートは各ブロックに記載してあります)







【回路図ノート】

- ・ケミコン、タンタルを除くコンデンサで、耐圧50V以下のものはその耐圧を省略。単位はすべて μF (pはpF)。
- ・チップ抵抗で指示のないものは、 $1/10\text{W}$ 以下。
 $k\Omega=1000\Omega$, $M\Omega=1000k\Omega$
- ・チップ部品交換時の注意
 取り外した部品は再使用せず、未使用の部品をご使用ください。
- ・タンタルコンデンサのマイナス側は熱に弱いので注意してください。

- ・チップ部品には下記のように表示したものがあります。

例	C 541	L 452
	22U	10UH
	TA A	2520
	↑ ↑	↑
	種類 ケースサイズ	外形寸法 (mm)

- ・抵抗、コンデンサ、ICなど定数にXXがあるものは、使用していない事を示しています。このため、使用していない回路が記載されている事があります。
- ・★印のある部品は、機種などにより異なりますので機能別マウント一覧表を参照してください。
- ・可変抵抗と半固定抵抗で、B特性の表示を省略。
- ・信号名表記について、下記のような場合があります。
 XEDIT → EDIT PB/XREC → PB/REC

- ・ は不燃性抵抗。
- ・ はヒューズ抵抗。
- ・ はパネル表示名称。
- ・ はB+ライン。
- ・ はB-ライン。
- ・ はBライン (+, -) の入出力方向を示す。
- ・ は調整名称。

【電圧・波形測定条件ノート】

- ・電圧値及び信号波形はパターンボックスのカラーバーチャートを被写体としたときの測定点对アース間の参考値。
 (デジタルマルチメータ; 入力インピーダンス DC10M Ω 使用)
- ・使用テストの入力インピーダンスにより電圧値が多少異なります。

イメージ交換時の注意

- ・イメージを交換した場合は、カメラ部の全調整を行ってください。
- ・イメージは構造上、静電気により破壊される恐れがあるため、MOS ICと同様に注意して取り扱ってください。
 また、受光部にはゴミの付着、および強い光がはいることのないように注意してください。

1. 接続図

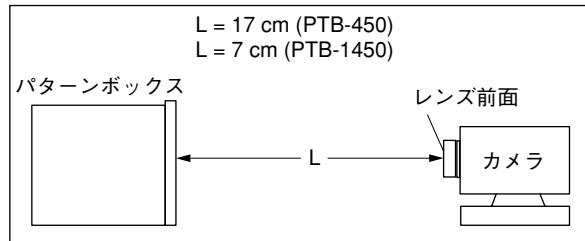
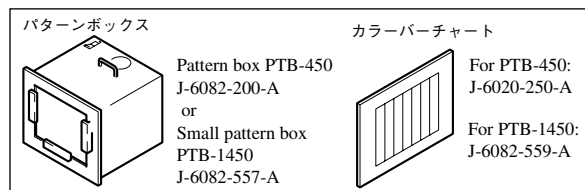

2. 図a及び図bの波形が得られるように画枠調整して下さい。

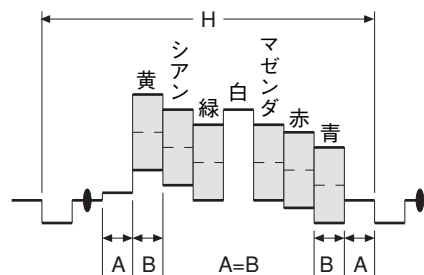

図a (映像入出力端子出力波形)

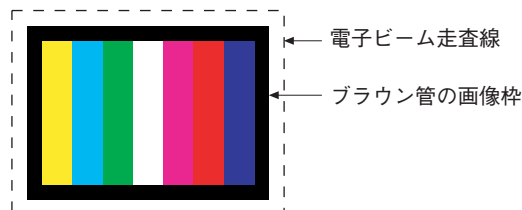

図b (テレビモニタの映像)

△印の部品、または△印付きの点線で囲まれた部品は、安全性を維持するために重要な部品です。従って交換時は、必ず指定の部品を使用して下さい。

お願い
 図面番号で部品を指定するときは基板名又はブロックを併せて指定して下さい。

Schematic diagrams of the CMS-007 and SY-218 boards are not shown.
Pages from 4-4 to 4-15 are not shown.

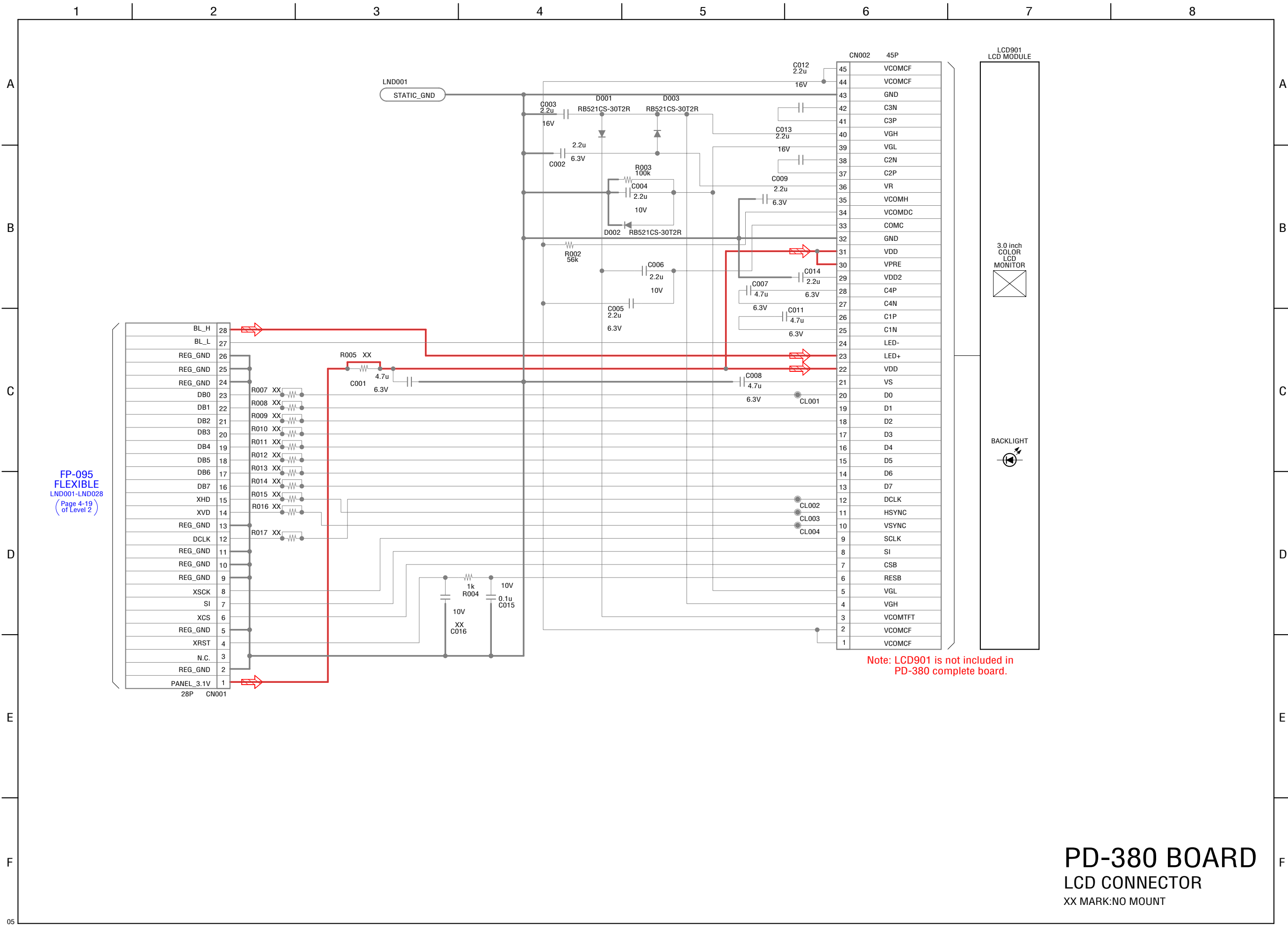

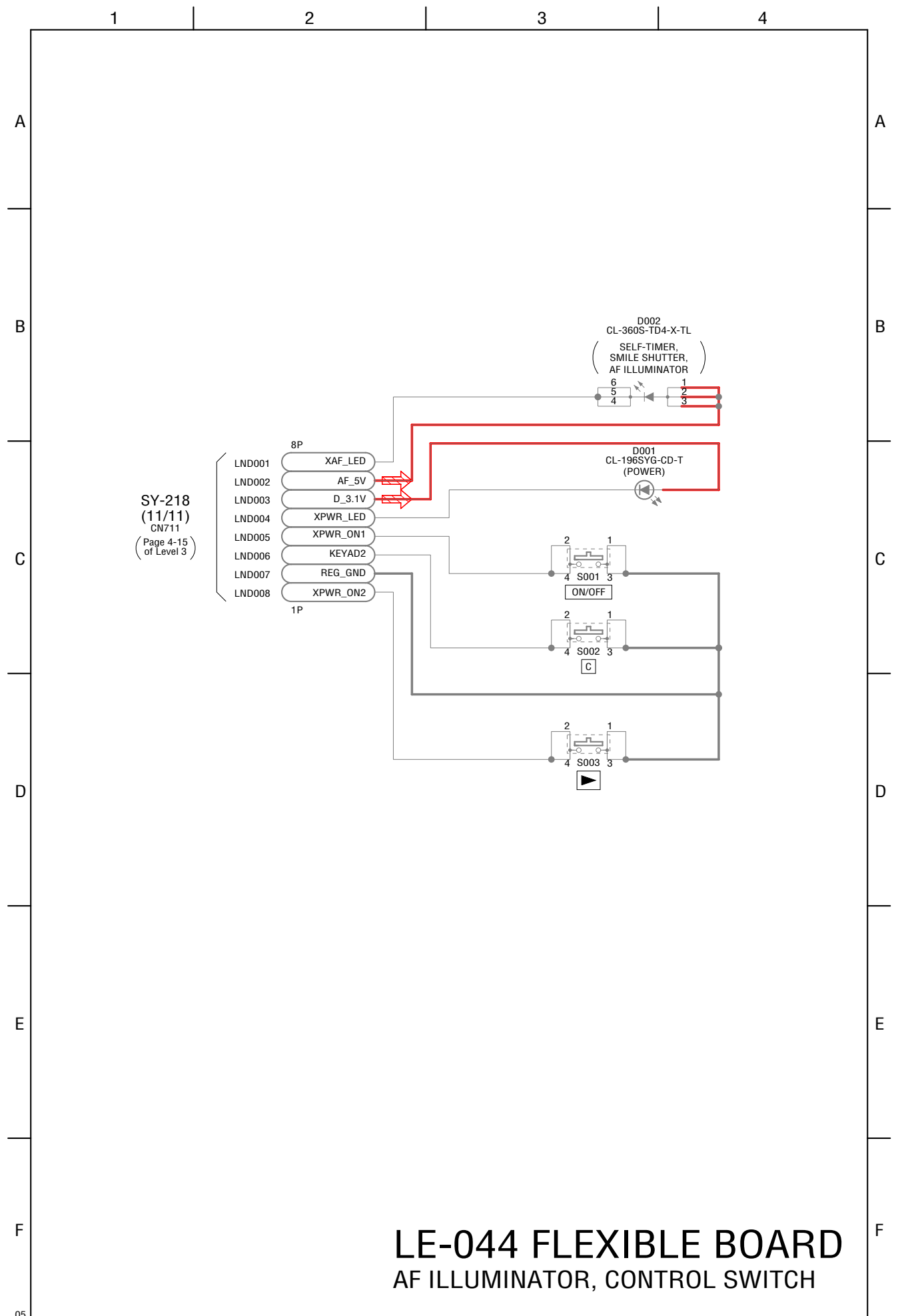
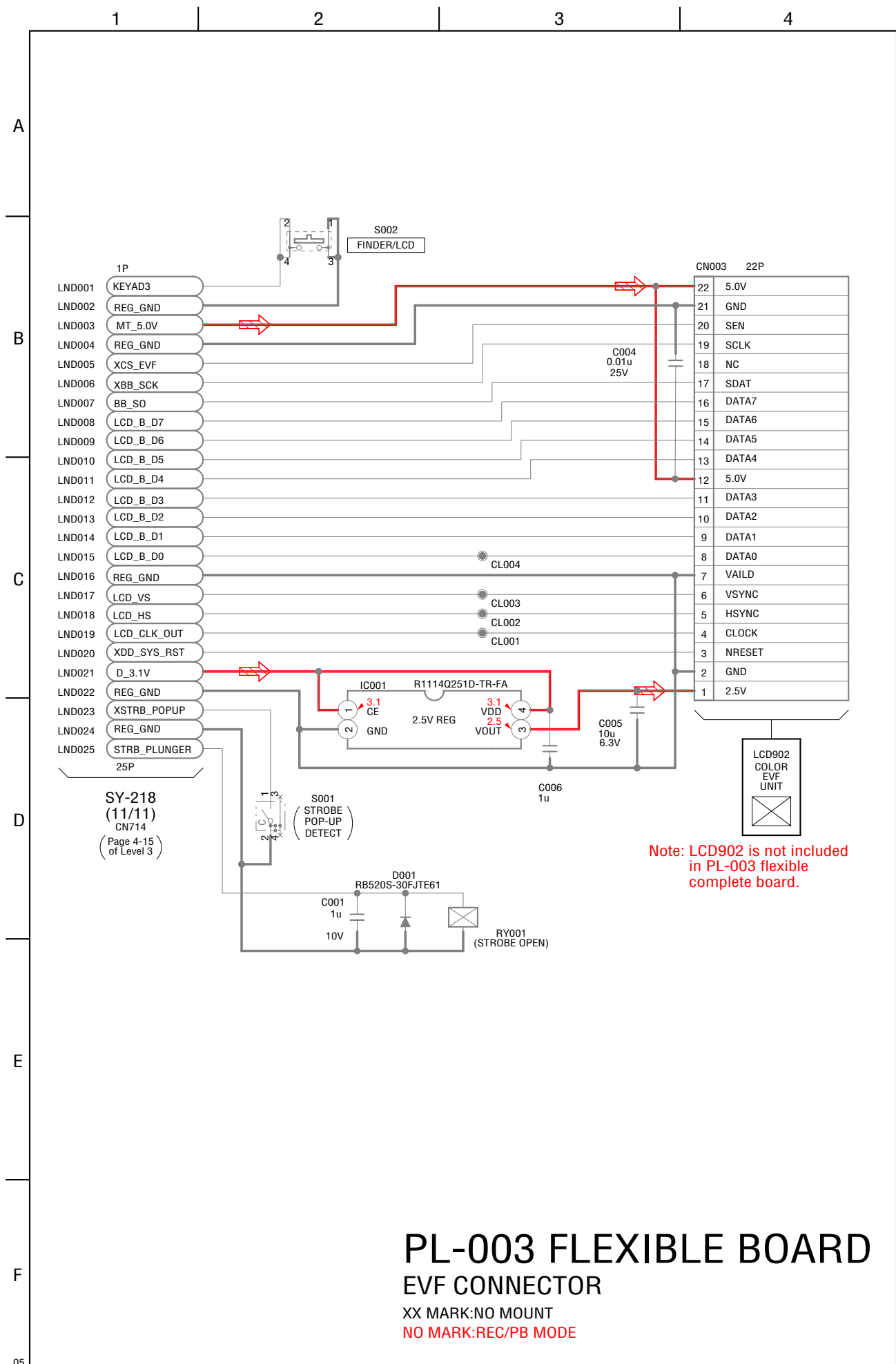

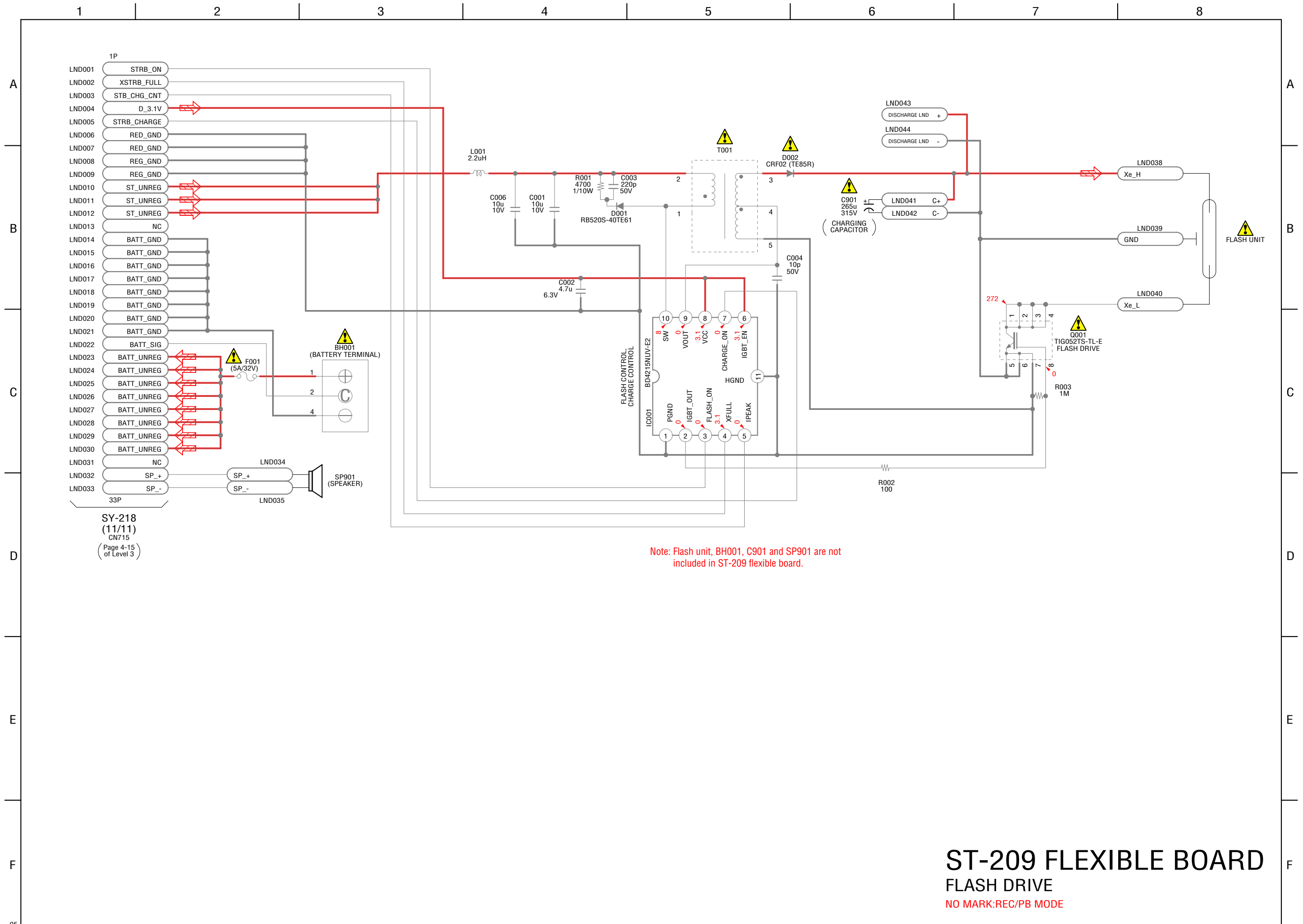

Note: Flash unit, BH001, C901 and SP901 are not included in ST-209 flexible board.

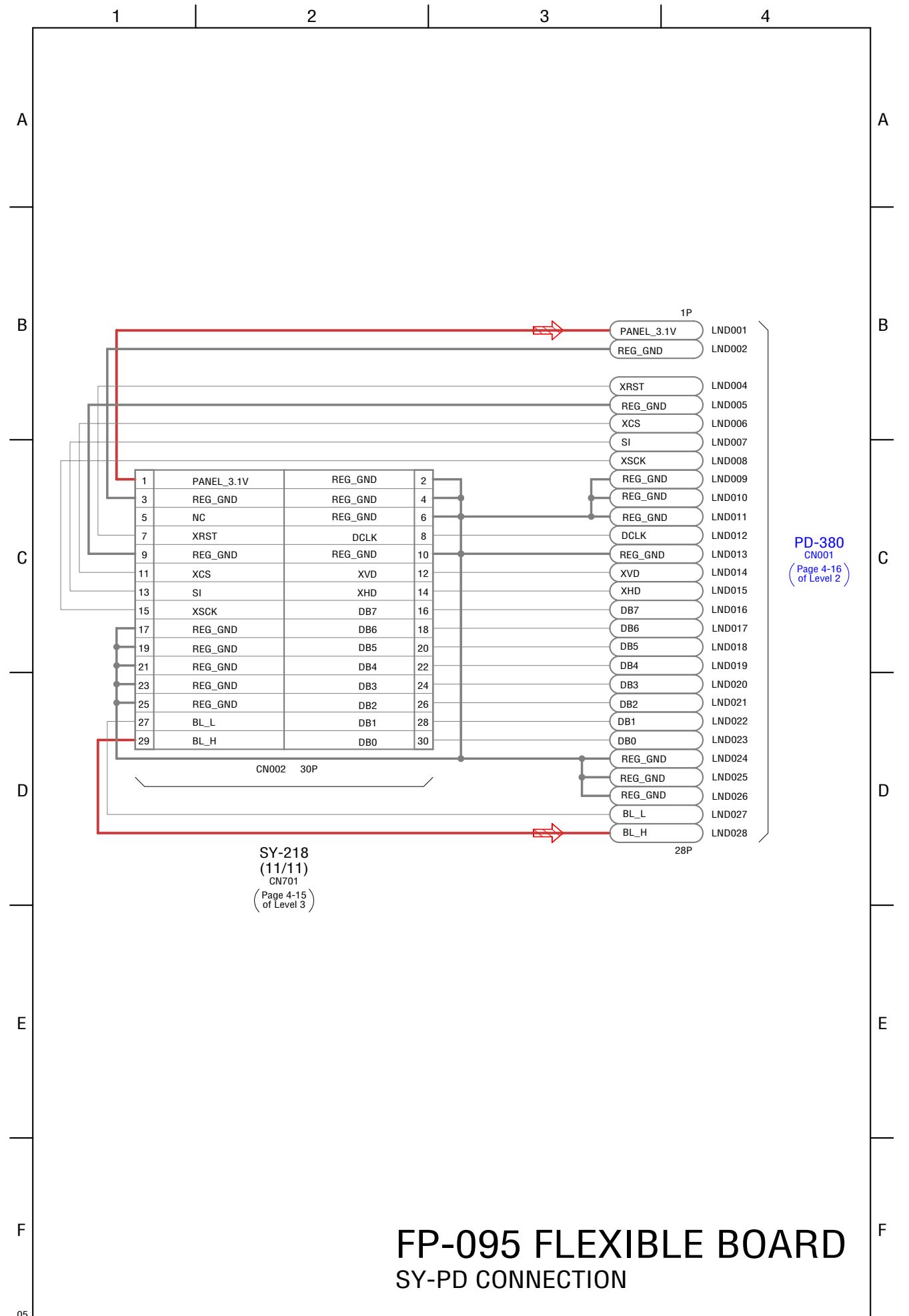
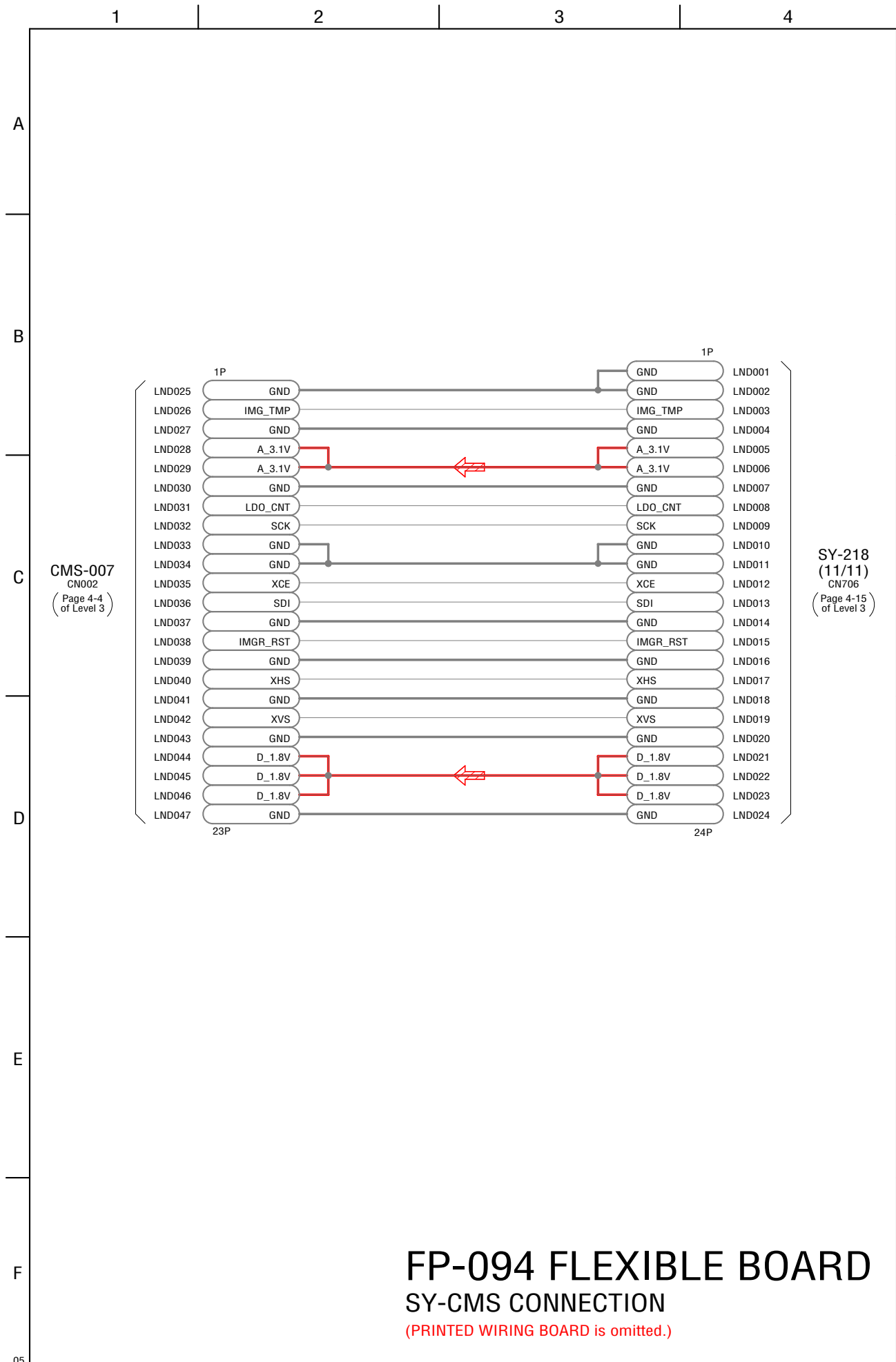

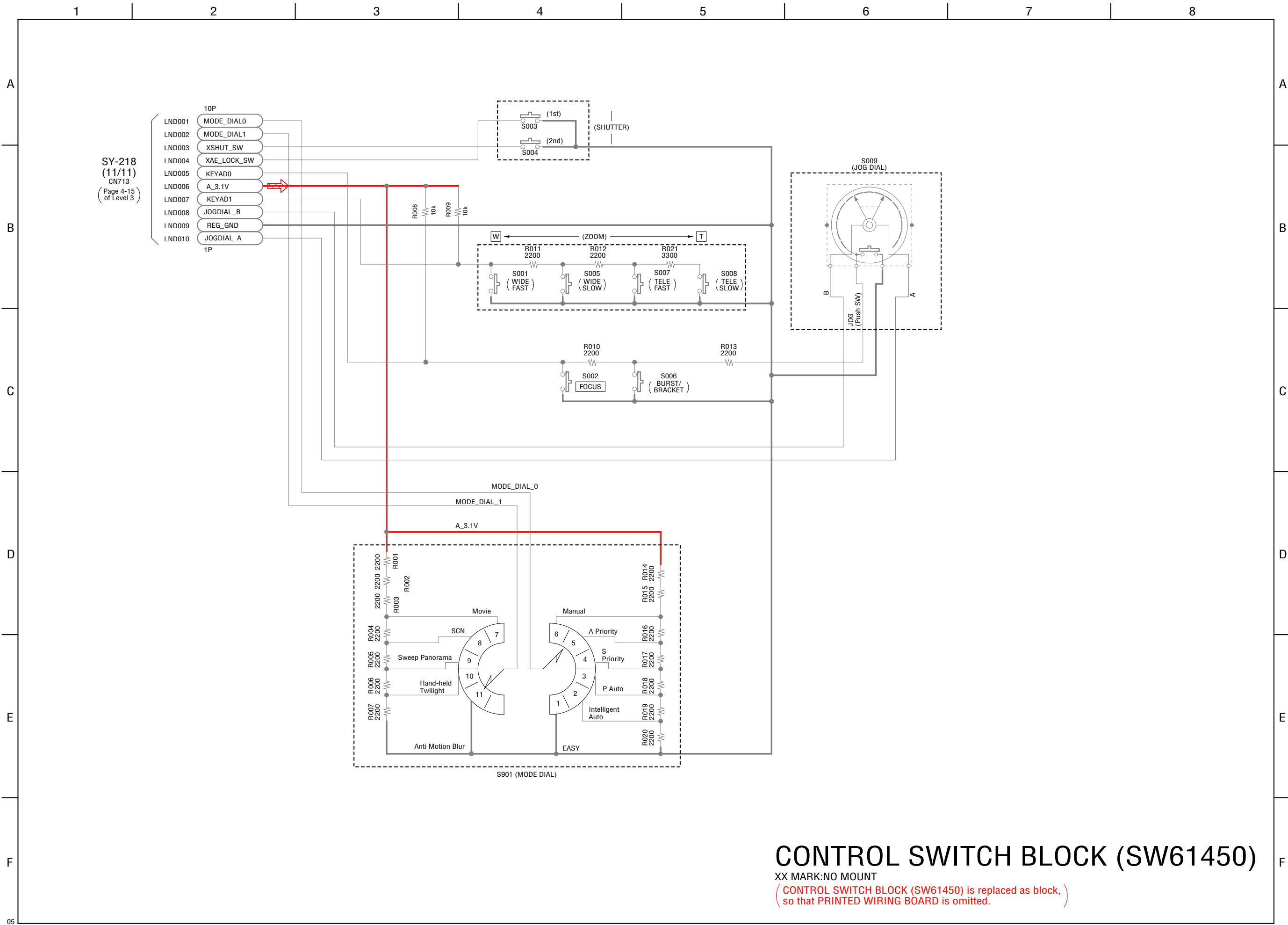

CONTROL SWITCH BLOCK (SW61450)
 XX MARK:NO MOUNT
 (CONTROL SWITCH BLOCK (SW61450) is replaced as block,
 so that PRINTED WIRING BOARD is omitted.)

4-3. PRINTED WIRING BOARDS

Link

• PD-380 BOARD

• LE-044 FLEXIBLE BOARD

• FP-095 FLEXIBLE BOARD

• ST-209 FLEXIBLE BOARD

• PL-003 FLEXIBLE BOARD







• COMMON NOTE FOR PRINTED WIRING BOARDS

4-3. PRINTED WIRING BOARDS

4-3. PRINTED WIRING BOARDS

(ENGLISH)

THIS NOTE IS COMMON FOR PRINTED WIRING BOARDS

-  : Uses unleaded solder.
-  : Circuit board
-  : Flexible board
-  : Pattern from the side which enables seeing.
-  : pattern of the rear side
(The other layers' patterns are not indicated)
- Through hole is omitted.
- There are a few cases that the part printed on diagram isn't mounted in this model.
-  : panel designation

• Chip parts.

Transistor

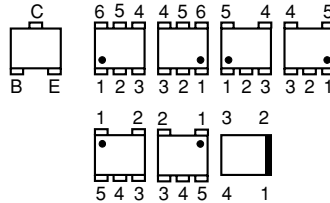



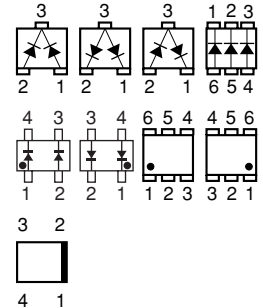



Diode



(JAPANESE)

プリント図共通ノート

【プリント図ノート】

-  : 無鉛半田を使用しています。
-  : 基板
-  : フレキシブル配線板
-  : 見ている面側のパターン。
-  : 裏側のパターン
(他のパターンについては表示されていません)
- スルーホールは省略。
- プリント図には、本機で使用していない部品が記載されている場合があります。
-  はパネル表示名称。

Printed wiring boards of the CMS-007 and SY-218 boards are not shown.
Pages from 4-22 to 4-24 are not shown.

PD-380 (2 layers), FP-095 (1 layer)

 : Uses unleaded solder.

PD-380 BOARD

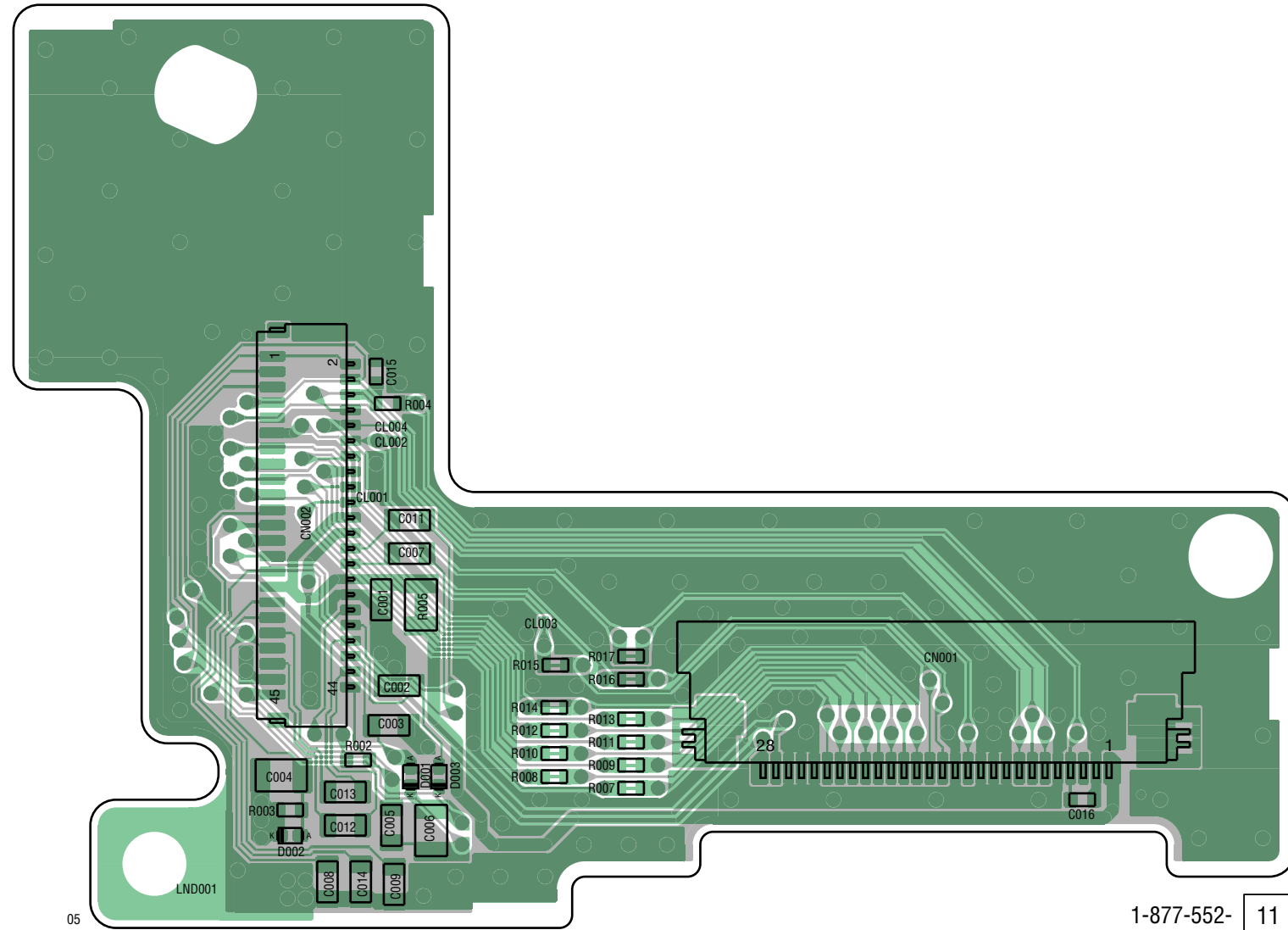

FP-095 FLEXIBLE BOARD

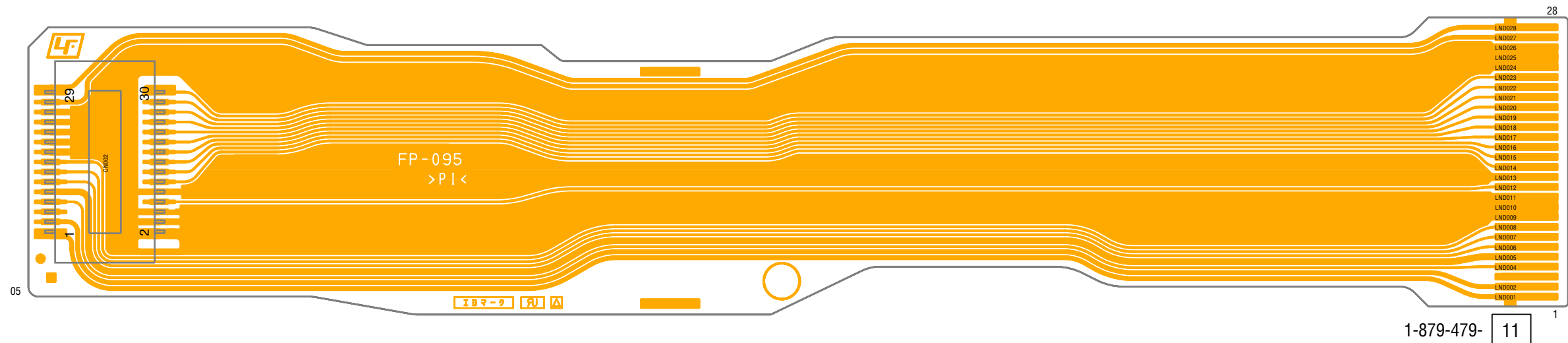

 : Uses unleaded solder.

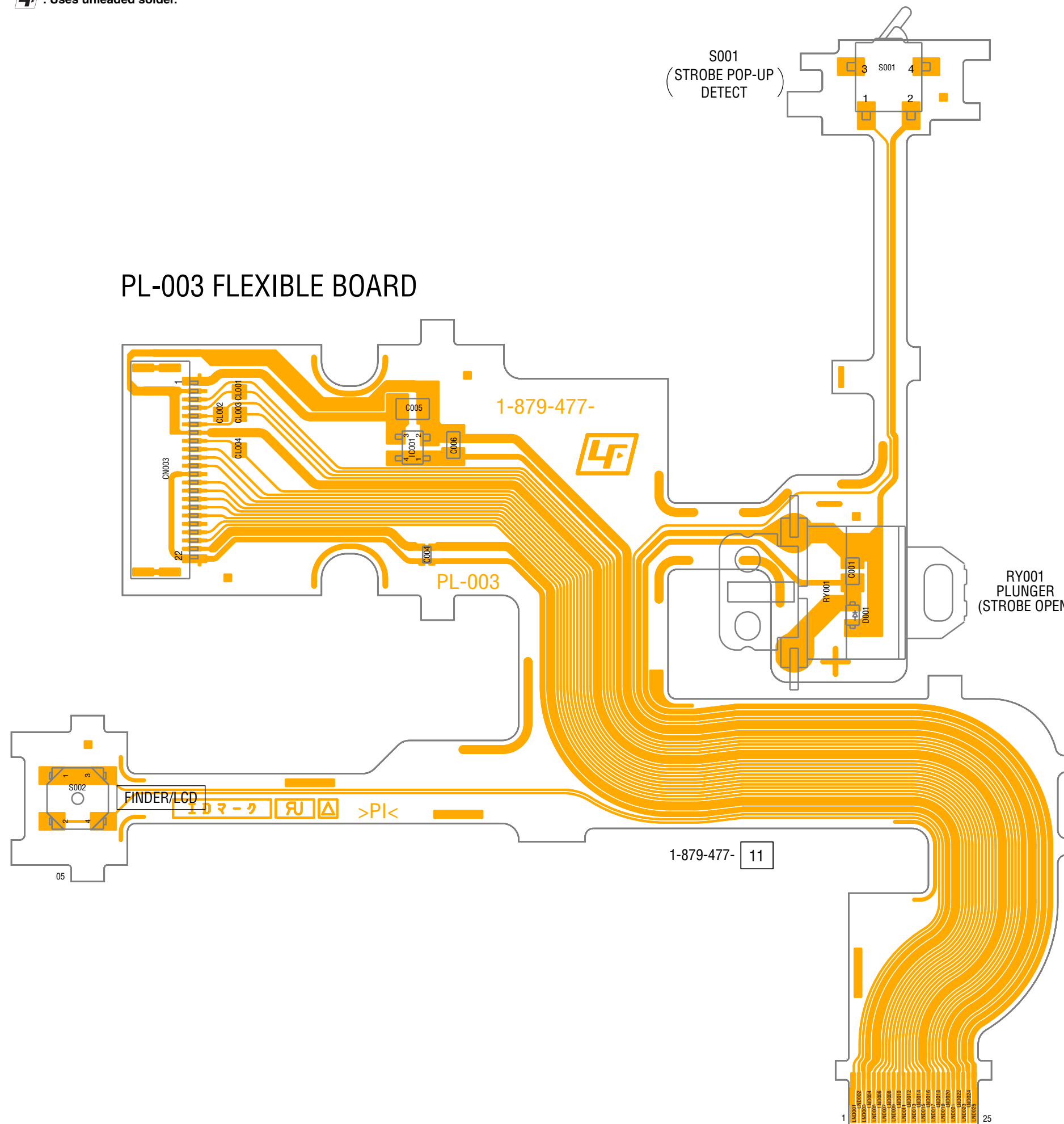

LE-044 FLEXIBLE BOARD

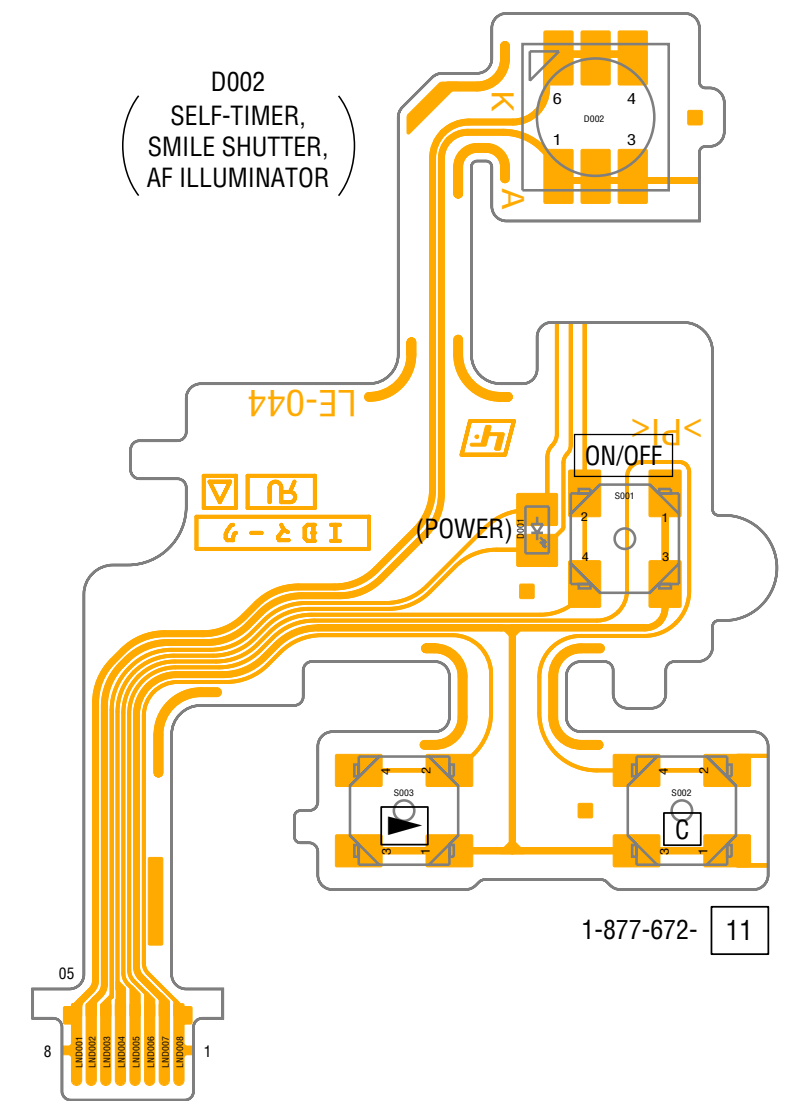

ST-209 FLEXIBLE BOARD

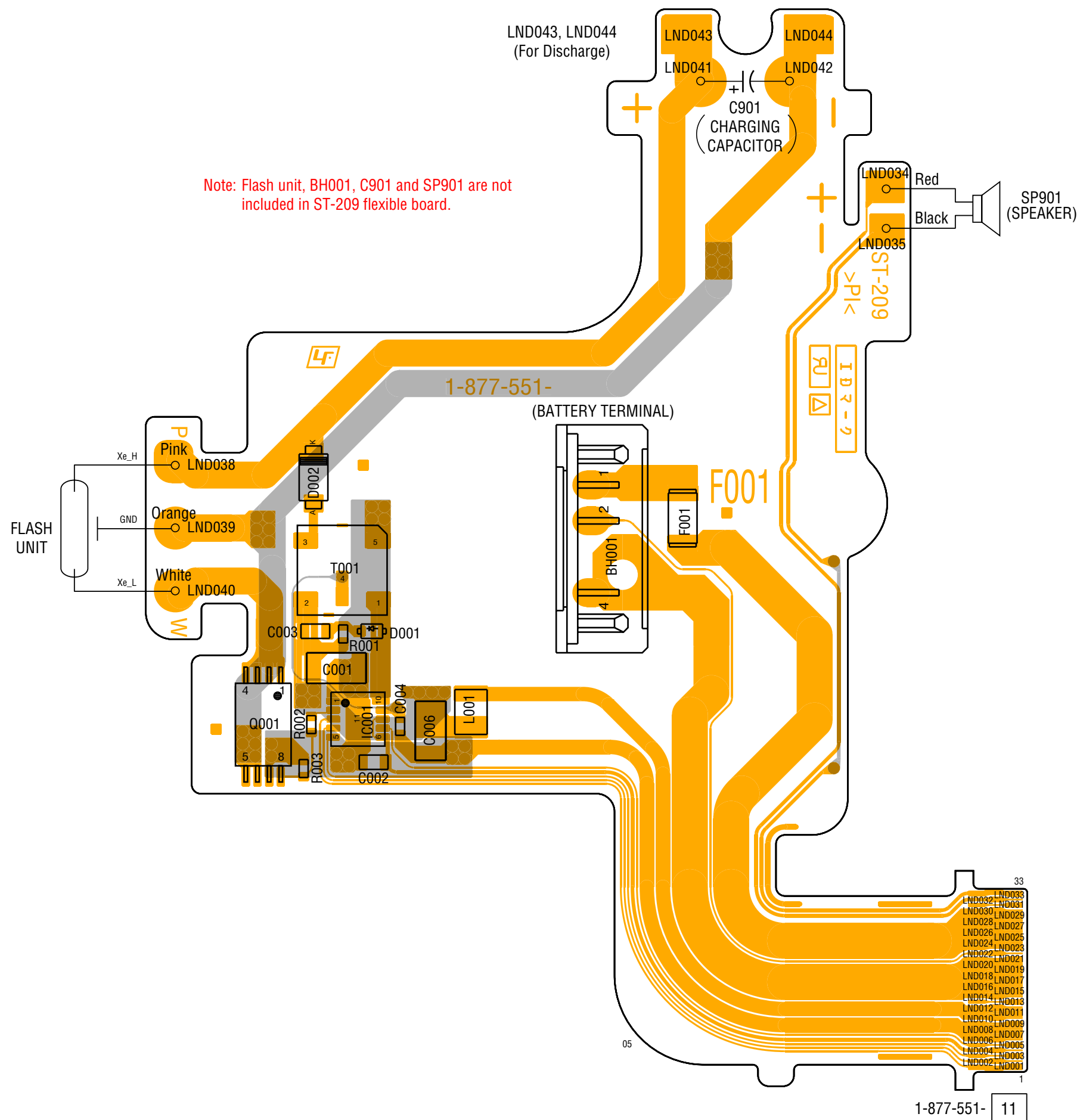

5. REPAIR PARTS LIST

NOTE: Characters **A** to **Z** of the electrical parts list indicate location of exploded views in which the desired part is shown.

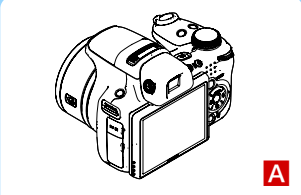
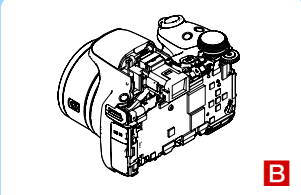
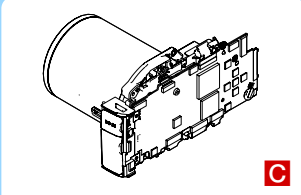
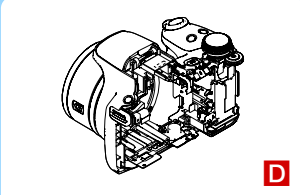
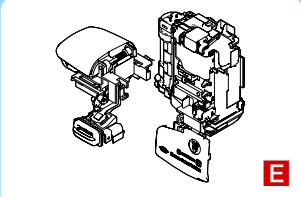
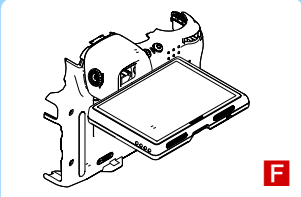
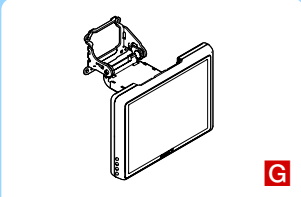
Link	EXPLODED VIEWS		
 A	 B	 C	 D
CABINET (UPPER) SECTION	EVF SECTION	MOUNTING BLOCK SECTION	CABINET (FRONT) SECTION
 E	 F	 G	
ST BLOCK SECTION	CABINET (REAR) SECTION	LCD PANEL SECTION	
Link	ELECTRICAL PARTS LIST		ACCESSORIES
FP-095 FLEXIBLE BOARD G	PD-380 BOARD G	ST-209 FLEXIBLE BOARD E	
LE-044 FLEXIBLE BOARD D	PL-003 FLEXIBLE BOARD E		

5. REPAIR PARTS LIST

5. REPAIR PARTS LIST

(ENGLISH)

NOTE:

- -XX, -X mean standardized parts, so they may have some differences from the original one.
- Items marked "*" are not stocked since they are seldom required for routine service. Some delay should be anticipated when ordering these items.
- The mechanical parts with no reference number in the exploded views are not supplied.
- Due to standardization, replacements in the parts list may be different from the parts specified in the diagrams or the components used on the set.
- CAPACITORS:
uF: μ F
- COILS
uH: μ H
- RESISTORS
All resistors are in ohms.
METAL: metal-film resistor
METAL OXIDE: Metal Oxide-film resistor
F: nonflammable
- SEMICONDUCTORS
In each case, u: μ , for example:
uA...: μ A..., uPA..., μ PA...,
uPB..., μ PB..., uPC..., μ PC...,
uPD..., μ PD...

(JAPANESE)

【使用上の注意】

- ここに記載されている部品は、補修用部品であるため、回路図及びセットに付いている部品と異なる場合があります。
- -XX, -Xは標準化部品のため、セットに付いている部品と異なる場合があります。
- *印の部品は常備在庫しておりません。
- コンデンサの単位でuFは μ Fを示します。
- 抵抗の単位 Ω は省略してあります。
金 被：金属被膜抵抗。
サンキン：酸化金属被膜抵抗。
- インダクタの単位でuHは μ Hを示します。
- 半導体の名称でuA..., uPA..., uPB..., uPC..., uPD...等はそれぞれ μ A..., μ PA..., μ PB..., μ PC..., μ PD...を示します。

When indicating parts by reference number, please include the board name.

The components identified by mark \triangle or dotted line with mark \triangle are critical for safety. Replace only with part number specified.

Les composants identifiés par une marque \triangle sont critiques pour la sécurité. Ne les remplacer que par une pièce portant le numéro spécifié.

- Color Indication of Appearance Parts
Example:
(SILVER) : Cabinet's Color
(Silver) : Parts Color

お願い
図面番号で部品を指定するときは基板名又はブロックを併せて指定してください。

\triangle 印の部品、または \triangle 印付の点線で囲まれた部品は、安全性を維持するために、重要な部品です。従って交換時は、必ず指定の部品を使用してください。

- 外装部品色表示
例：
(SILVER):セットの色を表す。
(Silver) : 部品の色を表す。

- Abbreviation
AR : Argentine model
AUS : Australian model
BR : Brazilian model
CH : Chinese model
CND : Canadian model
EE : East European model
HK : Hong Kong model
J : Japanese model
JE : Tourist model
KR : Korea model
NE : North European model
TW : Taiwan model
TH : Thai model

5. REPAIR PARTS LIST

DISASSEMBLY

HARDWARE LIST

5-1. EXPLODED VIEWS

5-1-1. CABINET (UPPER) SECTION

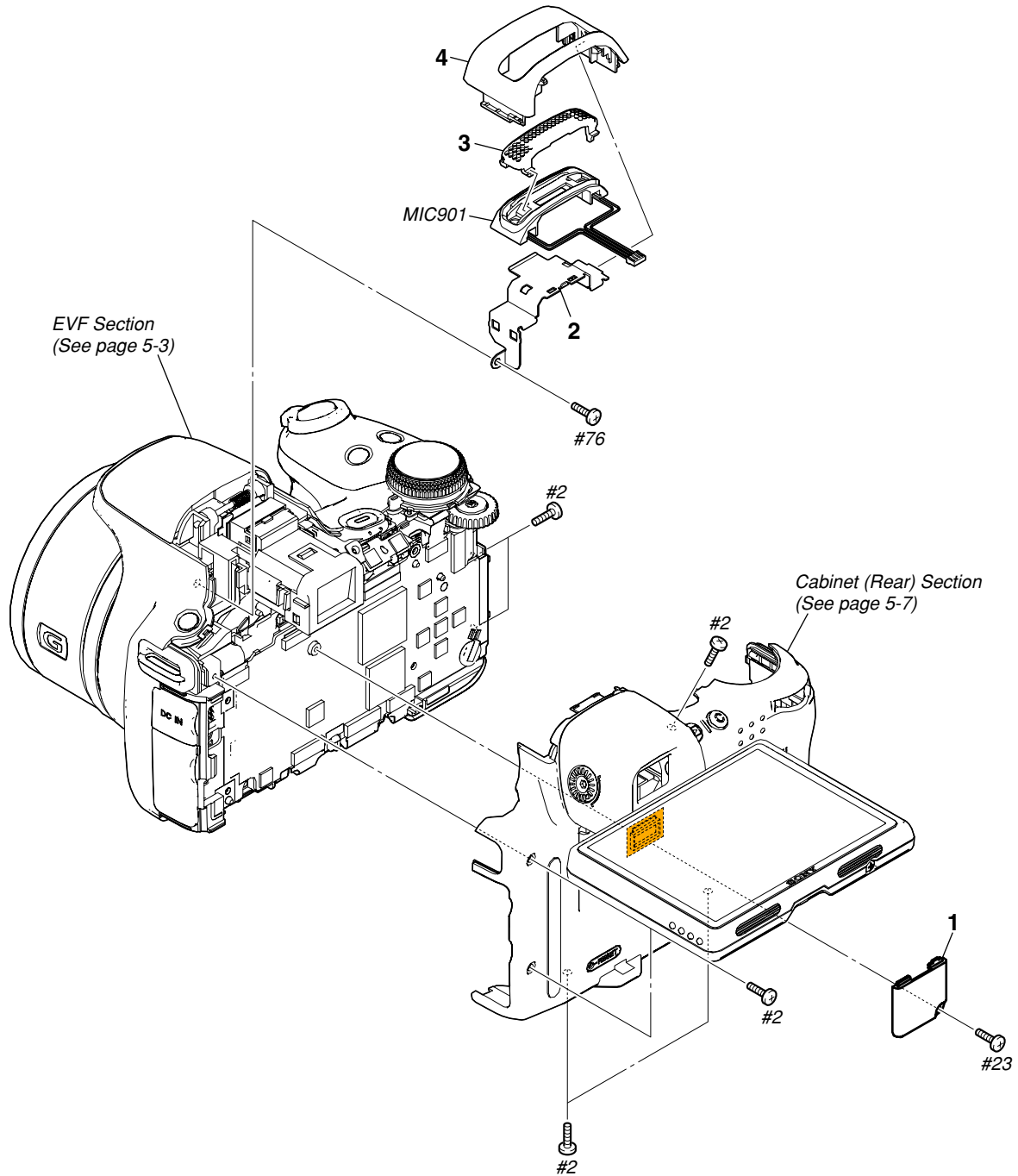

Ref. No.	Part No.	Description
1	4-142-440-01	DRIVING, SY MECHANICAL
* 2	4-142-452-01	PLATE (MIC), GROUND
3	4-142-451-01	GRILLE, MICROPHONE
4	4-142-446-01	CABINET (UPPER)
MIC901	1-542-800-11	MICROPHONE UNIT (STEREO)

Ref. No.	Part No.	Description
#2	2-635-562-31	SCREW (M1.7) (Black)
#23	3-080-204-11	SCREW, TAPPING, P2 (Black)
#76	2-666-551-11	SCREW, TAPPING, P2 (Silver)

5. REPAIR PARTS LIST

DISASSEMBLY

HARDWARE LIST

5-1-2. EVF SECTION

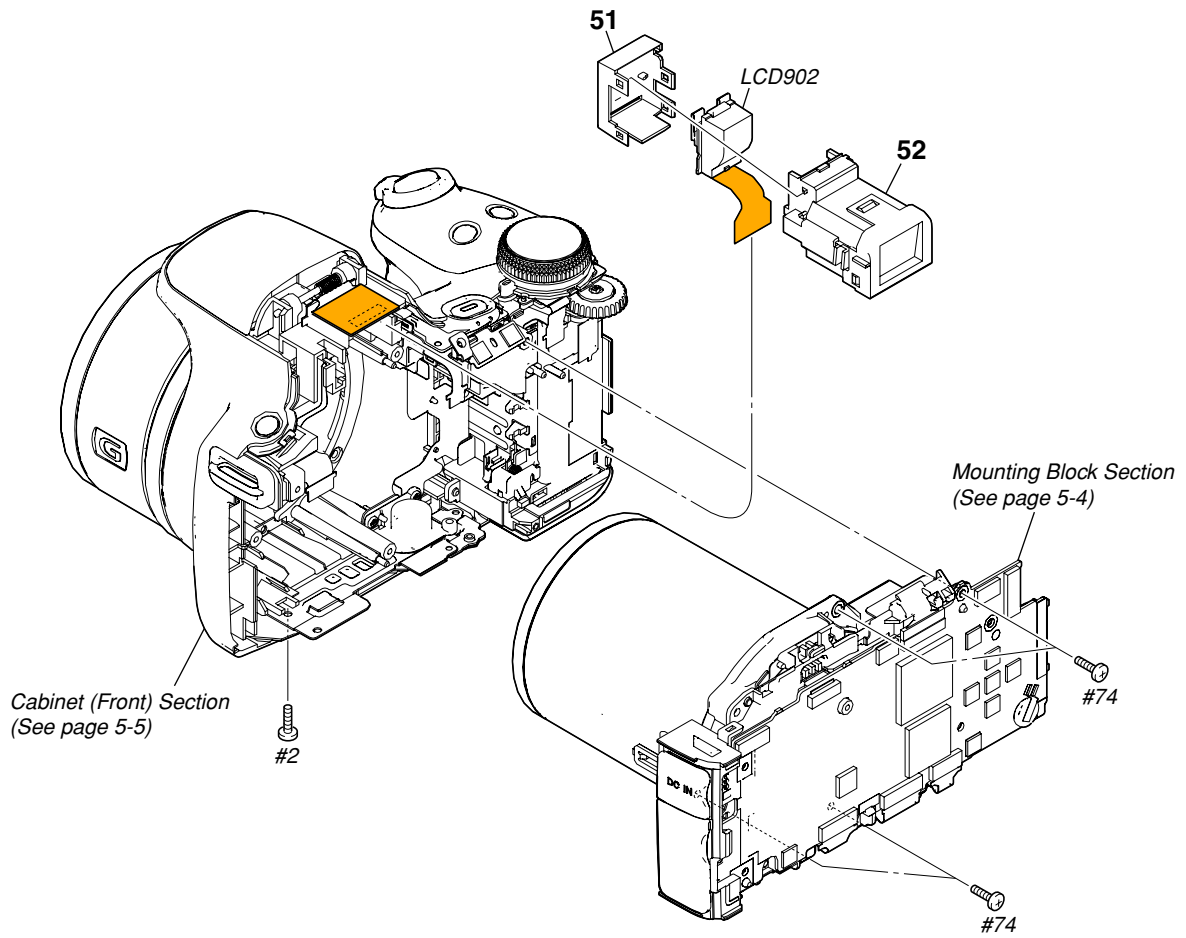

Ref. No.	Part No.	Description
51	4-142-469-01	RETAINER, MODULE
52	X-2190-274-1	VF ASSY (470)
LCD902	1-802-033-12	LCD MODULE

Ref. No.	Part No.	Description
#2	2-635-562-31	SCREW (M1.7) (Black)
#74	2-666-551-31	SCREW, TAPPING, P2 (Silver)

5. REPAIR PARTS LIST

DISASSEMBLY

HARDWARE LIST

5-1-3. MOUNTING BLOCK SECTION

Note: Be sure to read "Precautions for Replacement of Imager" on page 4-2 when changing the imager.

Note: イメージャの交換時は4-3ページの“イメージャ交換時の注意”を必ずお読みください。

CAUTION
 Danger of explosion if battery is incorrectly replaced.
 Replace only with the same or equivalent type.
 Dispose of used batteries according to the instructions.

注意
 電池の交換は、正しく行わないと破裂する恐れがあります。
 電池を交換する場合には必ず同じ型名の電池又は同等品と交換してください。
 使用済み電池は、取扱指示に従って処分してください。

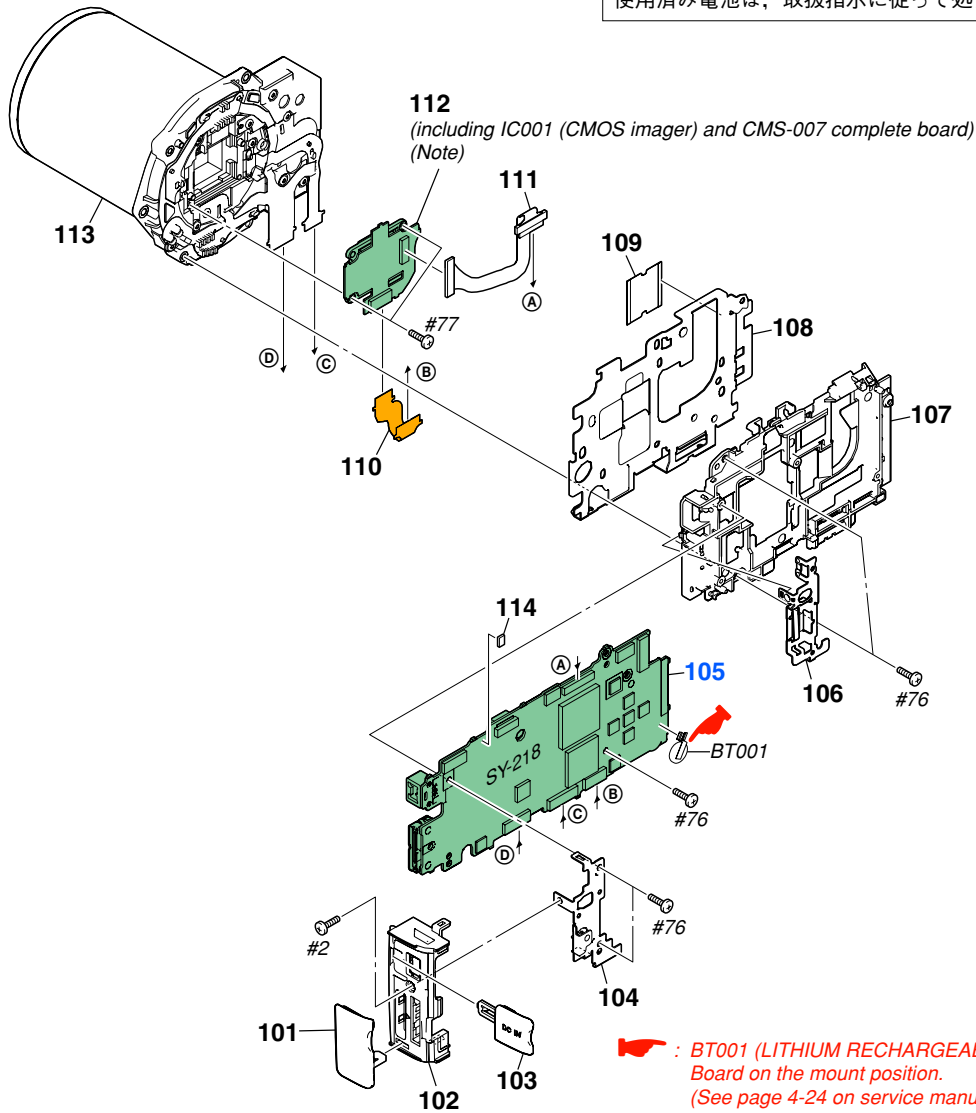

 : BT001 (LITHIUM RECHARGEABLE BATTERY)
 Board on the mount position.
 (See page 4-24 on service manual level 3)

• Refer to page 5-1 for mark △.

Ref. No.	Part No.	Description
101	4-142-438-01	COVER (MULTI)
102	4-142-429-01	GUIDE, JK COVER
103	4-142-437-01	COVER (DC)
* 104	4-142-432-01	PLATE (MULTI), FIXED
105	A-1705-721-A	SY-218 BOARD, COMPLETE (SERVICE)
* 106	4-142-433-01	PLATE (MULTI), GROUND
* 107	4-142-430-01	HOLDER, LENS
* 108	4-142-431-01	HEAT SINK, SY
* 109	4-142-434-01	SHEET (LENS HOLDER)
110	1-879-478-11	FP-094 FLEXIBLE BOARD

Ref. No.	Part No.	Description
111	1-966-557-11	HARNESS (HN-084)
112	A-1727-691-A	CMOS BLOCK ASSY (SERVICE) (Including IC001 (CMOS imager) and CMS-007 complete board) (Note)
113	A-1710-163-A	LENS BLOCK ASSY (SERVICE USE)
* 114	4-147-462-01	GASKET (RE)
△ BT001	1-756-813-11	LITHIUM RECHARGEABLE BATTERY
#2	2-635-562-31	SCREW (M1.7) (Black)
#76	2-666-551-11	SCREW, TAPPING, P2 (Silver)
#77	3-086-156-31	SCREW B1.2 (Silver)

5. REPAIR PARTS LIST

DISASSEMBLY

HARDWARE LIST

5-1-4. CABINET (FRONT) SECTION

ns: not supplied

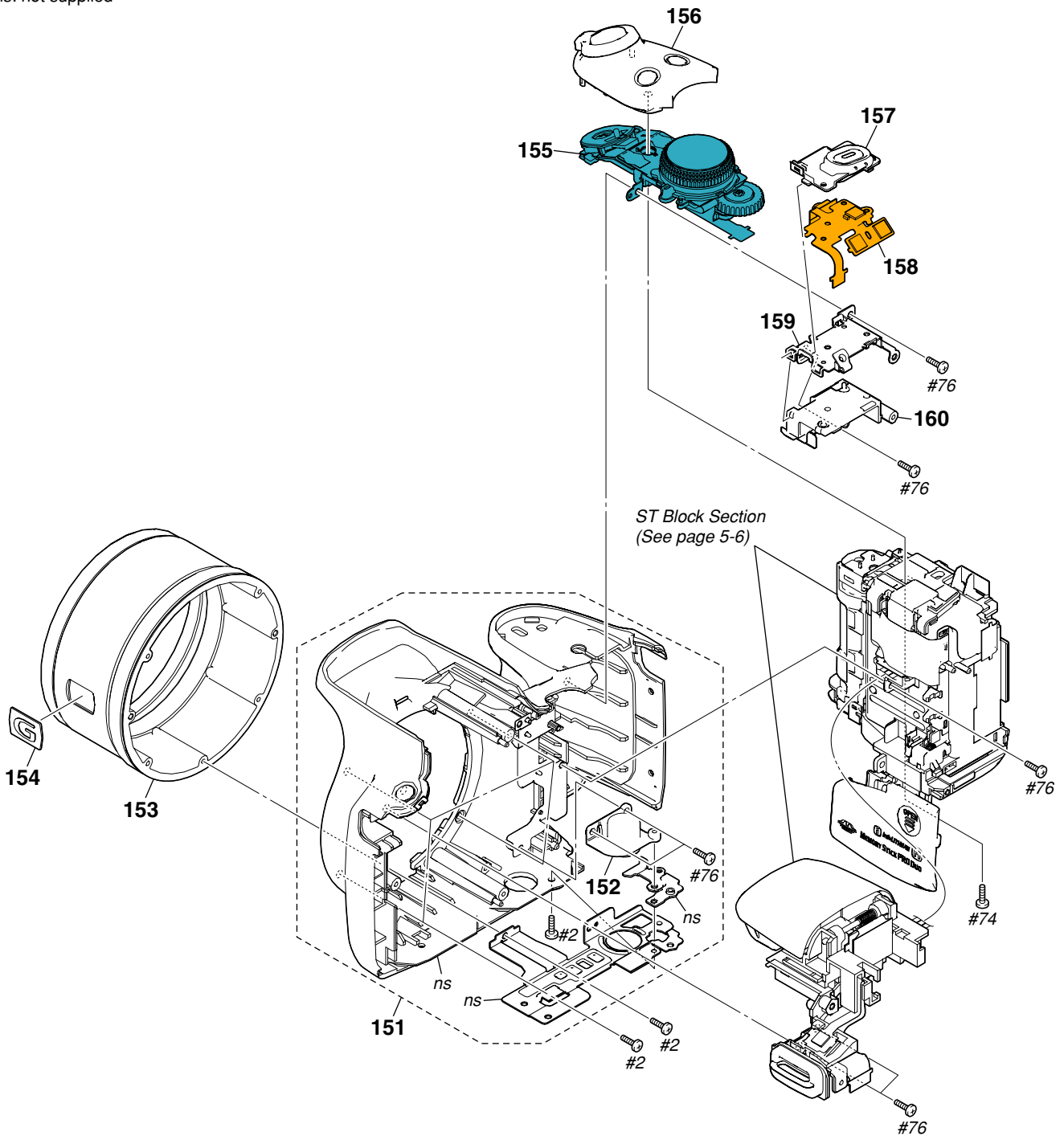

Ref. No.	Part No.	Description
151	X-2348-896-1	CABINET (FRONT) ASSY
152	3-106-766-01	SCREW, TRIPOD
153	4-142-496-01	RING (B), LENS
154	4-142-497-01	EMBLEM, G
155	1-487-154-11	SWITCH BLOCK, CONTROL (SW61450)
156	X-2348-895-1	RELEASE ASSY
157	X-2348-894-1	BUTTON ASSY, POWER

Ref. No.	Part No.	Description
158	A-1705-727-A	LE-044 FLEXIBLE BOARD, COMPLETE
* 159	4-142-484-01	PLATE (POWER), GROUND
* 160	4-142-483-01	RETAINER, AF
#2	2-635-562-31	SCREW (M1.7) (Black)
#74	2-666-551-31	SCREW, TAPPING, P2 (Silver)
#76	2-666-551-11	SCREW, TAPPING, P2 (Silver)

5. REPAIR PARTS LIST

HARDWARE LIST

5-1-5. ST BLOCK SECTION

ns: not supplied

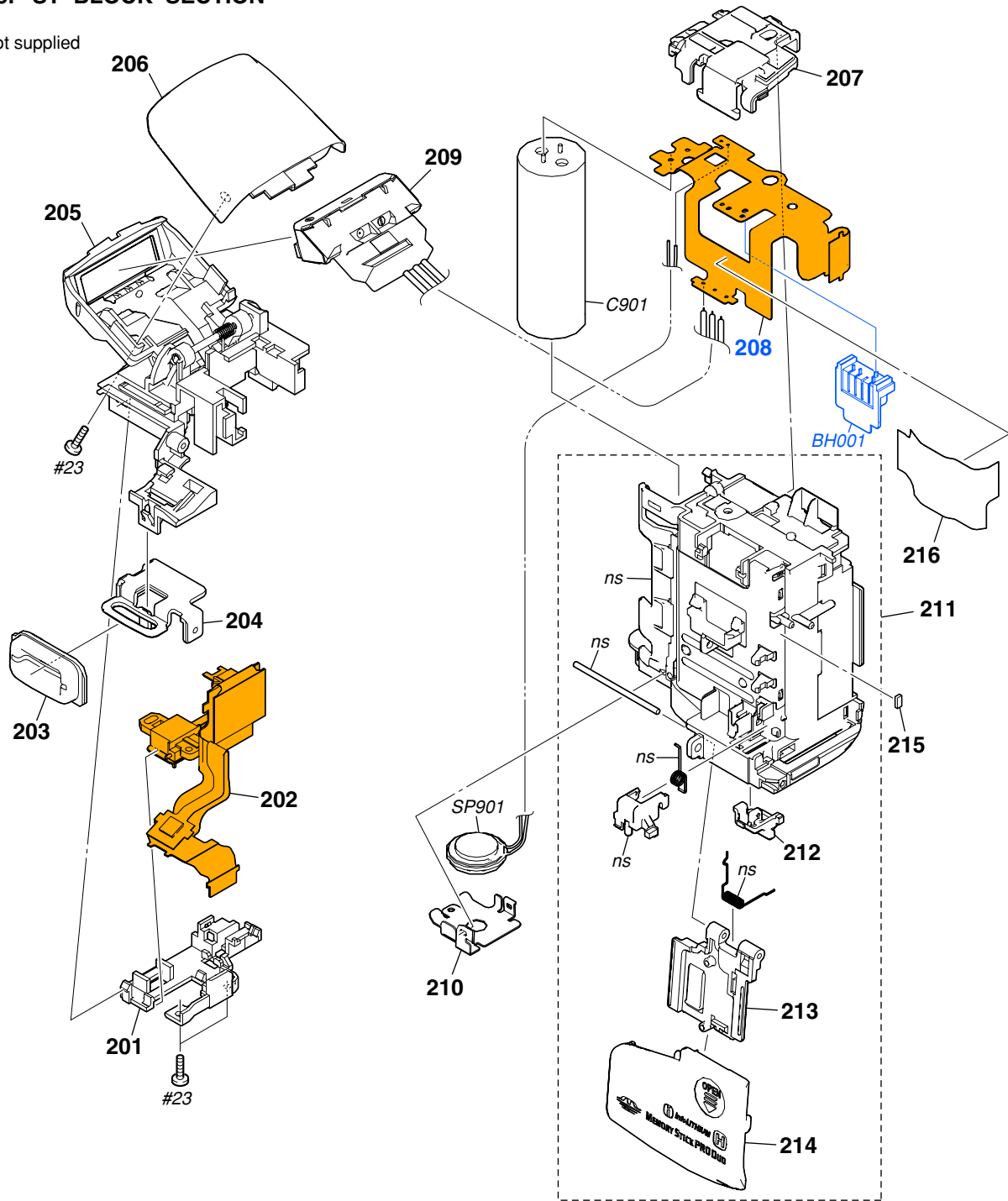

• Refer to page 5-1 for mark △.

Ref. No.	Part No.	Description
* 201	4-142-472-01	HOLDER, PL
202	A-1705-726-A	PL-003 FLEXIBLE BOARD, COMPLETE
* 203	4-142-436-01	FRAME (R), STRAP
* 204	4-142-435-01	SHEET METAL (R), STRAP
205	X-2348-893-1	BASE ASSY, ST
206	4-142-473-01	COVER, ST
* 207	4-141-669-01	COVER, BT TERMINAL
208	A-1705-725-A	ST-209 FLEXIBLE BOARD, COMPLETE
△ 209	1-487-161-11	FLASH UNIT
* 210	4-141-668-01	COVER, SP

Ref. No.	Part No.	Description
211	X-2348-780-1	BTH ASSY
* 212	4-141-665-01	CLAW, BT LOCK
* 213	4-141-660-01	BT HINGE
* 214	4-141-661-01	LID, BT
215	4-142-529-01	GASKET (BTH)
216	4-143-049-01	SHEET (ST FLEXIBLE)
△ BH001	1-780-064-21	BATTERY TERMINAL BOARD
△ C901	1-116-047-11	ELECT 265uF 315V
SP901	1-825-945-61	LOUDSPEAKER (1.3CM)
#23	3-080-204-11	SCREW, TAPPING, P2 (Black)

5. REPAIR PARTS LIST

DISASSEMBLY

HARDWARE LIST

5-1-6. CABINET (REAR) SECTION

ns: not supplied

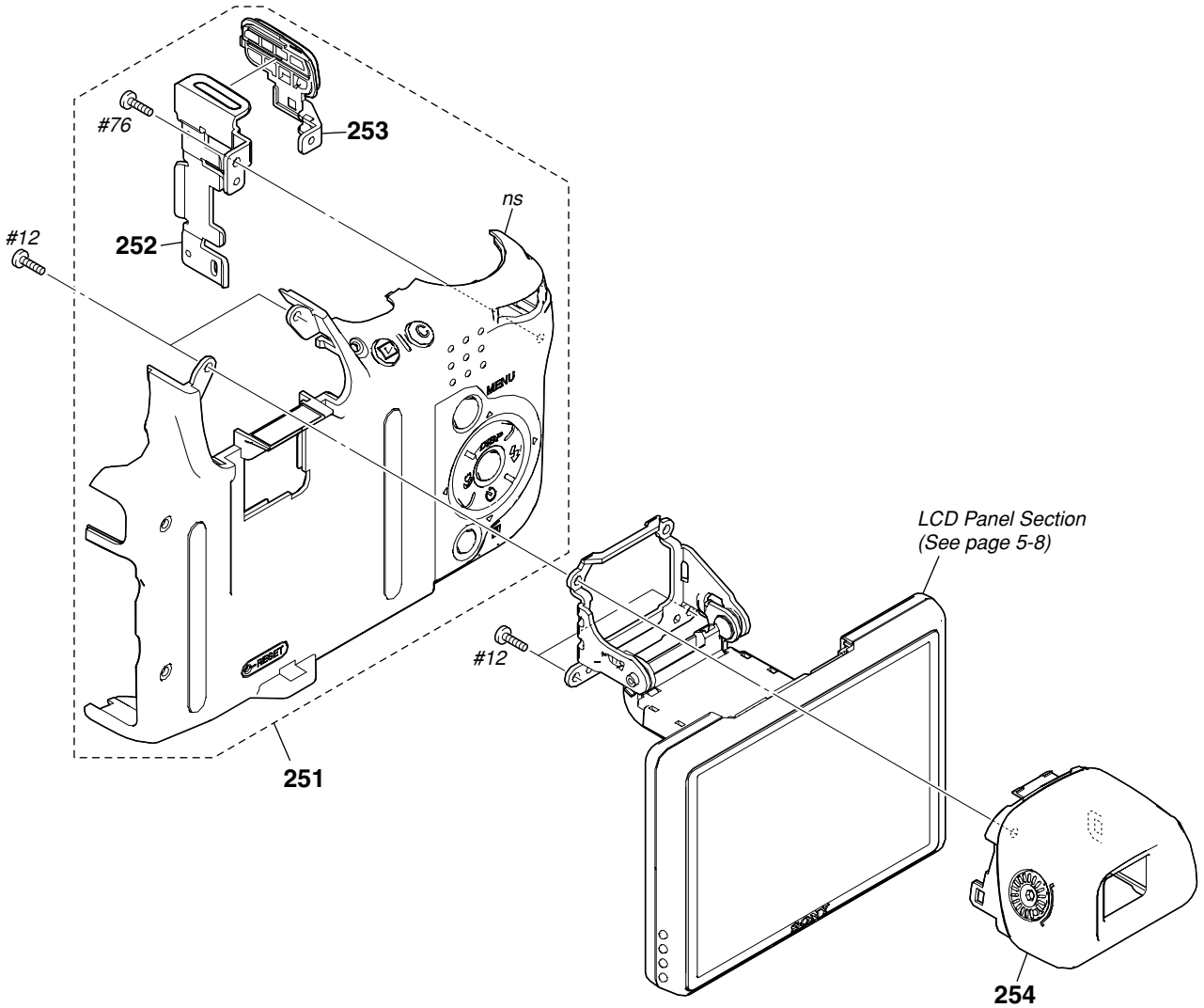

Ref. No.	Part No.	Description
251	X-2348-898-1	CABINET (REAR) ASSY
* 252	4-142-517-01	SHEET METAL (L), STRAP
* 253	4-142-518-01	FRAME (L), STRAP
254	X-2348-897-1	EYE CUP ASSY

Ref. No.	Part No.	Description
#12	3-080-204-21	SCREW, TAPPING, P2 (Black)
#76	2-666-551-11	SCREW, TAPPING, P2 (Silver)

5. REPAIR PARTS LIST

DISASSEMBLY

HARDWARE LIST

5-1-7. LCD PANEL SECTION

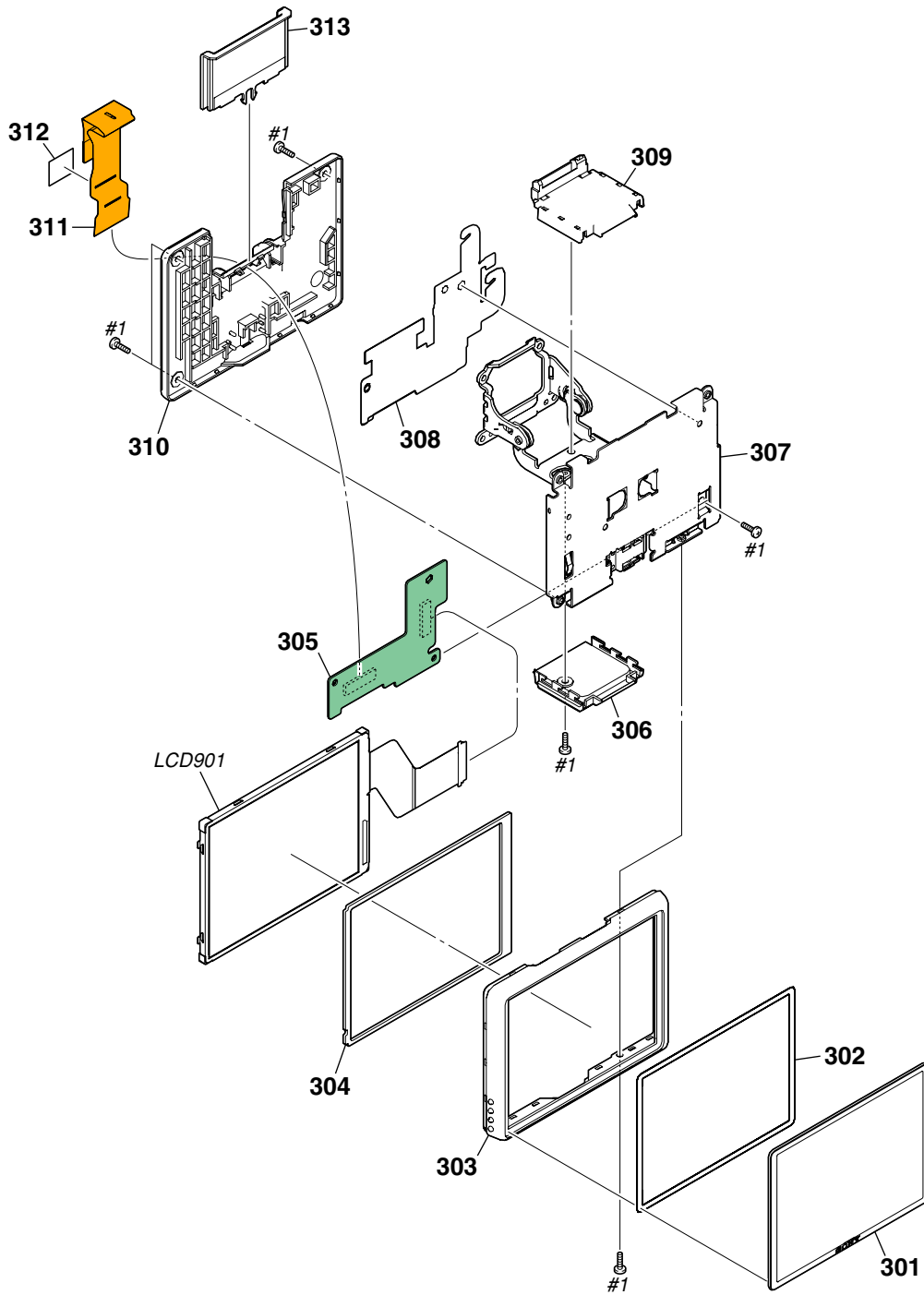

Ref. No.	Part No.	Description
301	4-142-459-01	WINDOW (61450), LCD
302	4-142-454-01	SHEET LCD WINDOW ADHESIVE
303	4-142-453-01	CABINET (M), P
304	4-142-458-01	CUSHION (LCD)
305	A-1705-724-A	PD-380 BOARD, COMPLETE
306	4-142-457-01	COVER (C), HINGE
307	X-2348-890-1	HINGE ASSY
308	4-142-455-01	INSULATING SHEET, CK

Ref. No.	Part No.	Description
309	X-2348-891-1	COVER (M) ASSY, HINGE
310	X-2348-892-1	CABINET (C) ASSY, P
311	A-1705-728-A	FP-095 FLEXIBLE BOARD, COMPLETE
*	3-213-424-01	SHEET, FLEXIBLE SLIDER
313	4-142-456-01	PLATE, BLIND
LCD901	1-802-831-11	LCD MODULE (LMS300GC05)
#1	2-635-562-11	SCREW (M1.7) (Black)

Electrical parts list of the CMS-007 board is not shown.
Page 5-9 is not shown.

5-2. ELECTRICAL PARTS LIST

Ref. No.	Part No.	Description	Ref. No.	Part No.	Description
	A-1705-728-A	FP-095 FLEXIBLE BOARD, COMPLETE *****		A-1705-726-A	PL-003 FLEXIBLE BOARD, COMPLETE *****
		< CONNECTOR >			< CAPACITOR >
CN002	1-778-596-21	CONNECTOR, BOARD TO BOARD 30P	C001	1-165-908-11	CERAMIC CHIP 1uF 10% 10V
			C004	1-100-567-81	CERAMIC CHIP 0.01uF 10% 25V
			C005	1-165-989-11	CERAMIC CHIP 10uF 10% 6.3V
			C006	1-165-908-11	CERAMIC CHIP 1uF 10% 10V
					< CONNECTOR >
	A-1705-727-A	LE-044 FLEXIBLE BOARD, COMPLETE *****	* CN003	1-816-649-51	FFC/CONNECTOR, FPC (LIF) 22P
		< DIODE >			< DIODE >
D001	6-500-594-01	DIODE CL-196SYG-CD-T (POWER)	D001	8-719-069-29	DIODE RB520S-30FJTE61
* D002	6-501-861-01	DIODE CL-360S-TD4-X-TL (SELF-TIMER, SMILE SHUTTER, AF ILLUMINATOR)			< IC >
		< SWITCH >	* IC001	6-708-464-01	IC R1114Q251D-TR-FA
* S001	1-786-914-31	SWITCH, TACTILE (ON/OFF)			< PLUNGER >
* S002	1-786-914-31	SWITCH, TACTILE (C)	* RY001	1-455-056-11	SOLENOID, PLUNGER
* S003	1-786-914-31	SWITCH, TACTILE (▶)			< SWITCH >
			S001	1-786-180-31	SWITCH, PUSH (1KEY) (STROBE POP-UP DETECT)
			* S002	1-786-914-31	SWITCH, TACTILE (FINDER/LCD)
	A-1705-724-A	PD-380 BOARD, COMPLETE *****		A-1705-725-A	ST-209 FLEXIBLE BOARD, COMPLETE *****
		< CAPACITOR >			< CAPACITOR >
* C001	1-112-746-11	CERAMIC CHIP 4.7uF 10% 6.3V	C001	1-165-875-11	CERAMIC CHIP 10uF 10% 10V
C002	1-165-884-11	CERAMIC CHIP 2.2uF 10% 6.3V	* C002	1-112-746-11	CERAMIC CHIP 4.7uF 10% 6.3V
C003	1-112-021-91	CERAMIC CHIP 2.2uF 20% 16V	C003	1-164-933-11	CERAMIC CHIP 220PF 10% 50V
C004	1-125-889-11	CERAMIC CHIP 2.2uF 10% 10V	C004	1-164-850-11	CERAMIC CHIP 10PF 0.5PF 50V
C005	1-165-884-11	CERAMIC CHIP 2.2uF 10% 6.3V	C006	1-165-875-11	CERAMIC CHIP 10uF 10% 10V
C006	1-125-889-11	CERAMIC CHIP 2.2uF 10% 10V			< DIODE >
* C007	1-112-746-11	CERAMIC CHIP 4.7uF 10% 6.3V	D001	6-500-619-01	DIODE RB520S-40TE61
* C008	1-112-746-11	CERAMIC CHIP 4.7uF 10% 6.3V	△ D002	6-501-096-01	DIODE CRF02 (TE85R)
C009	1-165-884-11	CERAMIC CHIP 2.2uF 10% 6.3V			< FUSE >
* C011	1-112-746-11	CERAMIC CHIP 4.7uF 10% 6.3V	△ F001	1-576-751-11	FUSE (5A/32V)
C012	1-112-021-91	CERAMIC CHIP 2.2uF 20% 16V			< IC >
C013	1-112-021-91	CERAMIC CHIP 2.2uF 20% 16V	* IC001	6-712-975-01	IC BD4215NUV-E2
C014	1-165-884-11	CERAMIC CHIP 2.2uF 10% 6.3V			< COIL >
C015	1-125-777-11	CERAMIC CHIP 0.1uF 10% 10V	* L001	1-400-820-11	INDUCTOR 2.2uH
		< CONNECTOR >			< TRANSISTOR >
* CN001	1-816-959-51	FFC/FPC CONNECTOR (ZIF) 28P	△* Q001	6-552-144-01	TR TIG052TS-TL-E
* CN002	1-821-202-81	CONNECTOR, FPC (ZIF) 45P			
		< DIODE >			
D001	6-501-568-01	DIODE RB521CS-30T2R			
D002	6-501-568-01	DIODE RB521CS-30T2R			
D003	6-501-568-01	DIODE RB521CS-30T2R			
		< RESISTOR >			
R002	1-218-974-11	METAL CHIP 56K 5% 1/16W			
R003	1-218-977-11	METAL CHIP 100K 5% 1/16W			
R004	1-218-953-11	METAL CHIP 1K 5% 1/16W			

• Refer to page 5-1 for mark △.

Ref. No.	Part No.	Description
< RESISTOR >		
R001	1-216-829-11	METAL CHIP 4.7K 5% 1/10W
R002	1-218-941-11	METAL CHIP 100 5% 1/16W
R003	1-218-989-11	METAL CHIP 1M 5% 1/16W

< TRANSFORMER >

△* T001 1-445-491-21 D.C.-D.C.CONVERTER TRANSFORMER



Electrical parts list of the SY-218 board is not shown.
Pages from 5-12 to 5-16 are not shown.

• Refer to page 5-1 for mark △.

Checking supplied accessories.

Note: This item is supplied with the unit as an accessory, but is not prepared as a service part.

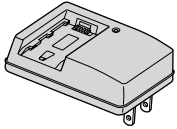

Battery Charger
BC-VH1

△ 1-487-152-11 (J)

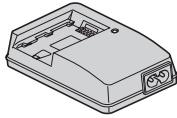

Battery Charger
BC-VH1

△ 1-487-152-21 (US, CND, JE)
△ 1-487-152-31 (EXCEPT US, CND, JE, J)



Instruction Manual

4-132-058-01 (JAPANESE) (J)
4-132-058-11 (ENGLISH) (CND, AEP, UK, E, HK, AUS, JE)
4-132-058-21 (FRENCH, ITALIAN) (CND, AEP)
4-132-058-31 (SPANISH, PORTUGUESE) (AEP, E, AR, JE)
4-132-058-41 (GERMAN, DUTCH) (AEP)
4-132-058-51 (TRADITIONAL CHINESE, SIMPLIFIED CHINESE) (E, HK, JE)
4-132-058-61 (RUSSIAN, UKRAINIAN) (AEP)
4-132-058-71 (ARABIC, PERSIAN) (E)
4-132-058-81 (KOREAN) (KR, JE)
4-132-058-91 (POLISH, CZECH) (AEP)
4-132-059-11 (HUNGARIAN, SLOVAK) (AEP)
4-132-059-21 (SWEDISH, FINNISH) (AEP)
4-132-059-31 (NORWEGIAN, DANISH) (AEP)
4-132-059-41 (CROATIAN, ROMANIAN) (AEP)
4-132-059-51 (TURKISH, GREEK) (AEP)
4-132-059-61 (ENGLISH, SPANISH) (US)
4-132-059-71 (SIMPLIFIED CHINESE) (CH)
4-132-059-81 (MALAY, INDONESIAN) (E)
4-132-059-91 (THAI) (E)



Power Cord (Mains Lead)
(EXCEPT J)

△ 1-783-952-71 (AR)
△ 1-832-121-41 (CH)
△ 1-832-169-41 (UK, HK)
△ 1-833-892-41 (KR)
△ 1-834-482-31 (AEP, E)
△ 1-834-484-31 (US, CND)
△ 1-835-983-11 (AUS)
△ 1-836-251-11 (JE)



Conversion (2P) Adaptor

△ 1-569-007-12 (JE)

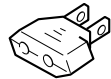

Conversion (2P) Adaptor

△ 1-569-008-12 (E (EXCEPT Middle East))

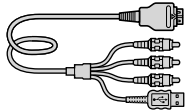

USB, A/V Cable for
Multi-use Terminal
1-836-364-11

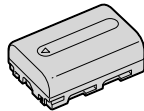

Rechargeable Battery Pack
NP-FH50
(Note)

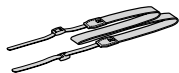

Shoulder Strap
2-629-892-11



HDMI Adaptor
1-822-552-11



Lens Cap
X-2177-459-1



Lens Cap Strap
3-979-194-41

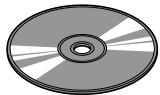

CD-ROM
(Cyber-shot application software/
"Cyber-shot Handbook"/
"Cyber-shot Step-up Guide")
4-132-051-01



Cyber-shot Handbook (PDF)

The CD-ROM supplied contains all of language version of the Instruction Manual in pdf (Cyber-shot Handbook.pdf) for printing.

- The printed matter is not supplied. If required, please order it with the part number below.

- (Only for destination Japanese model)

日本国内については日本語のみが印刷での部品供給可能です。

4-132-054-01 (JAPANESE)	* 4-132-055-61 (CZECH)
* 4-132-054-11 (ENGLISH)	* 4-132-055-71 (HUNGARIAN)
* 4-132-054-21 (FRENCH)	* 4-132-055-81 (SLOVAK)
* 4-132-054-31 (ITALIAN)	* 4-132-055-91 (SWEDISH)
* 4-132-054-41 (SPANISH)	* 4-132-056-11 (FINNISH)
* 4-132-054-51 (PORTUGUESE)	* 4-132-056-21 (NORWEGIAN)
* 4-132-054-61 (GERMAN)	* 4-132-056-31 (DANISH)
* 4-132-054-71 (DUTCH)	* 4-132-056-41 (THAI)
* 4-132-054-81 (TRADITIONAL CHINESE)	* 4-132-056-51 (MALAY)
* 4-132-054-91 (SIMPLIFIED CHINESE)	* 4-132-056-61 (TURKISH)
* 4-132-055-11 (RUSSIAN)	* 4-132-056-71 (GREEK)
* 4-132-055-21 (ARABIC)	* 4-132-056-81 (UKRAINIAN)
* 4-132-055-31 (PERSIAN)	* 4-132-056-91 (CROATIAN)
* 4-132-055-41 (KOREAN)	* 4-132-057-11 (ROMANIAN)
* 4-132-055-51 (POLISH)	* 4-132-057-21 (INDONESIAN)

• Refer to page 5-1 for mark △.

DSC-HX1

SONY®

SERVICE MANUAL

Ver. 1.2 2009.08

LEVEL 2

US Model
Canadian Model
AEP Model
UK Model
E Model
Australian Model
Hong Kong Model
Chinese Model
Korea Model
Argentine Model
Japanese Model
Tourist Model

SUPPLEMENT-1

File this supplement with the service manual.
(09-183)

- Change of Repair Parts

 : Points deleted portion.

5. REPAIR PARTS LIST

5-1. EXPLODED VIEWS

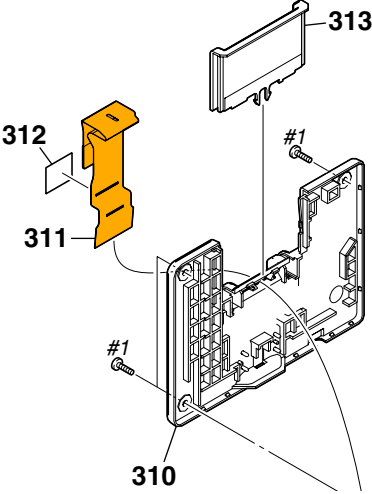
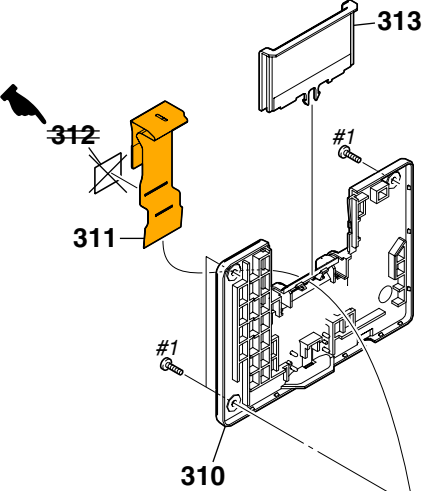
Page	Former	New									
5-8											
	<table border="1"><thead><tr><th>Ref. No.</th><th>Part No.</th><th>Description</th></tr></thead><tbody><tr><td>* 312</td><td>3-213-424-01</td><td>SHEET, FLEXIBLE SLIDER</td></tr></tbody></table>	Ref. No.	Part No.	Description	* 312	3-213-424-01	SHEET, FLEXIBLE SLIDER	<table border="1"><thead><tr><th>Ref. No.</th><th>Part No.</th><th>Description</th></tr></thead><tbody></tbody></table>	Ref. No.	Part No.	Description
Ref. No.	Part No.	Description									
* 312	3-213-424-01	SHEET, FLEXIBLE SLIDER									
Ref. No.	Part No.	Description									

HARDWARE LIST (1/9)

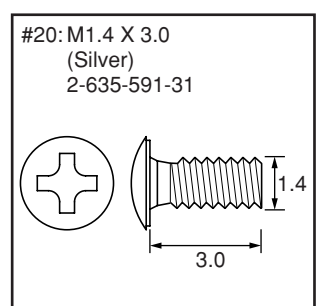
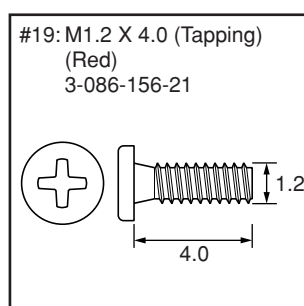
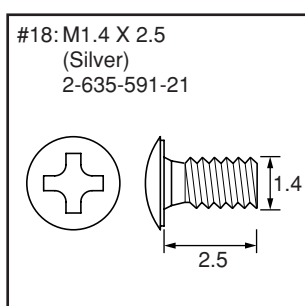
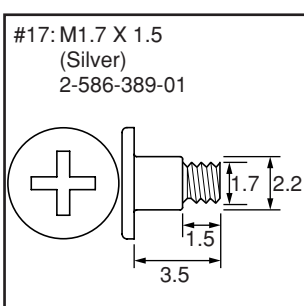
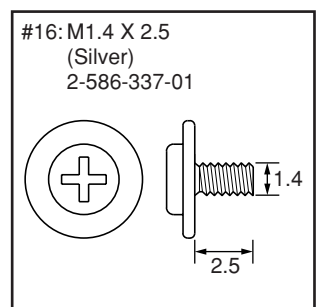
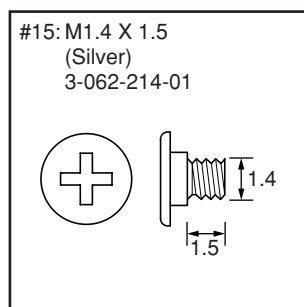
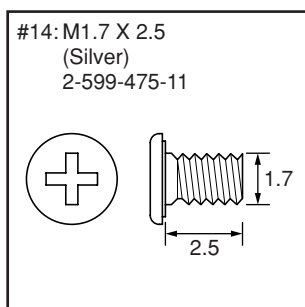
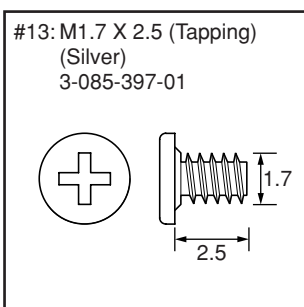
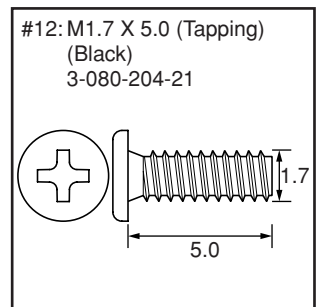
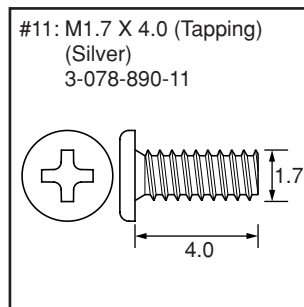
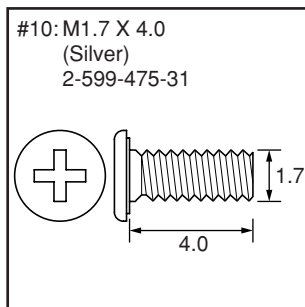
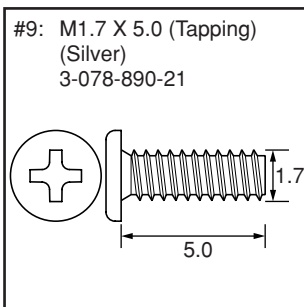
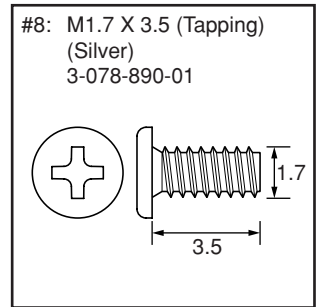
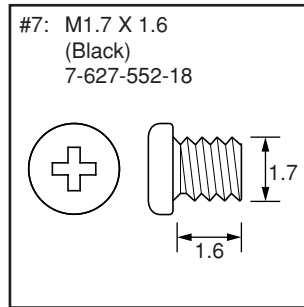
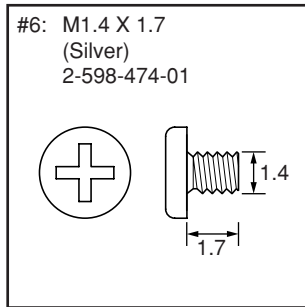
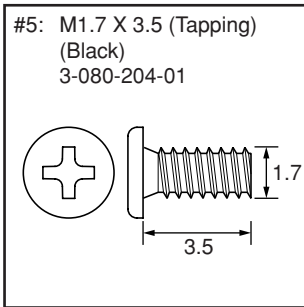
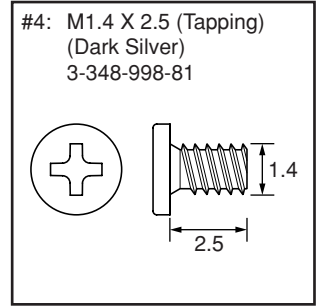
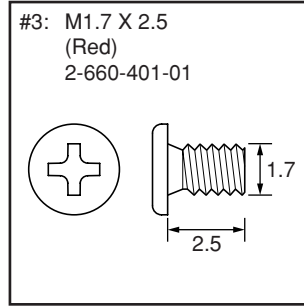
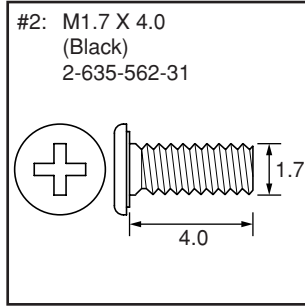
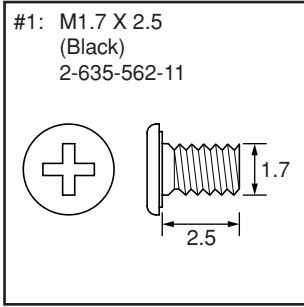

HARDWARE LIST (2/9)

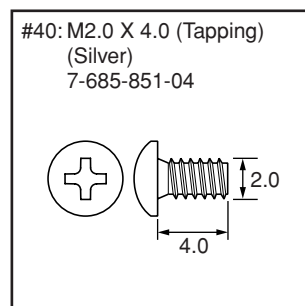
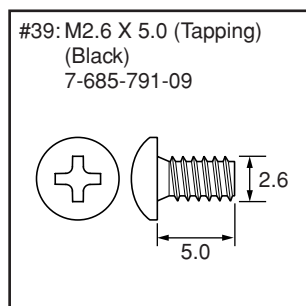
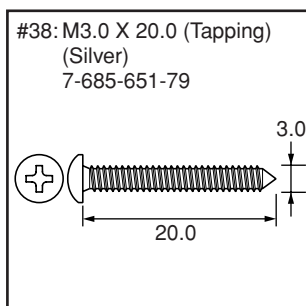
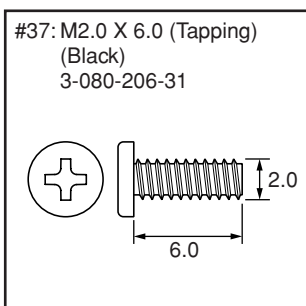
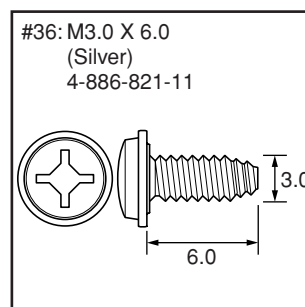
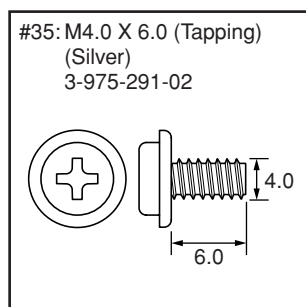
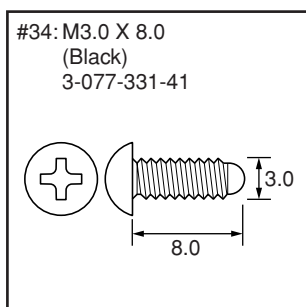
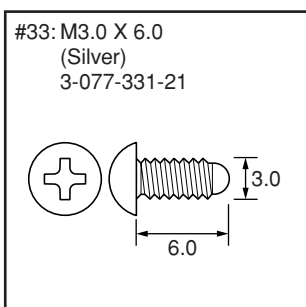
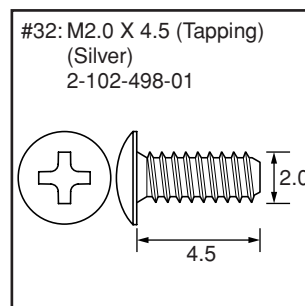
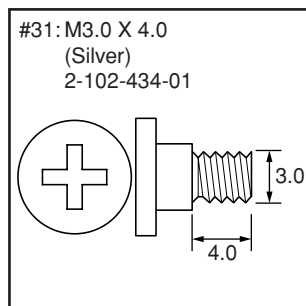
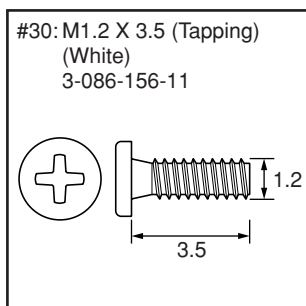
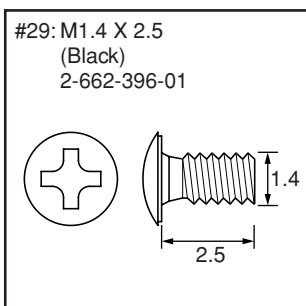
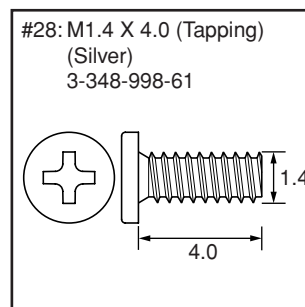
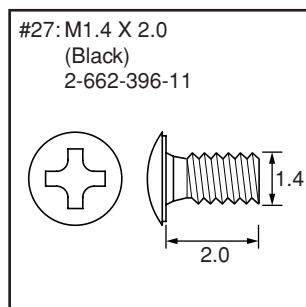
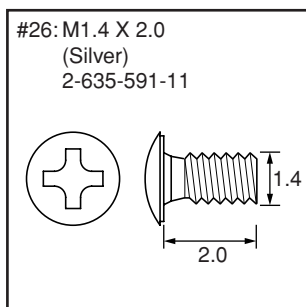
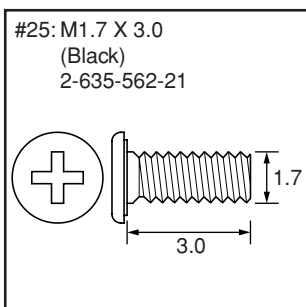
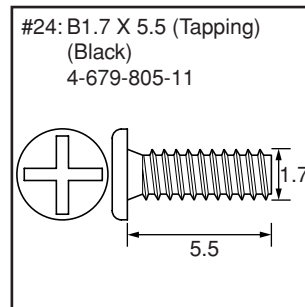
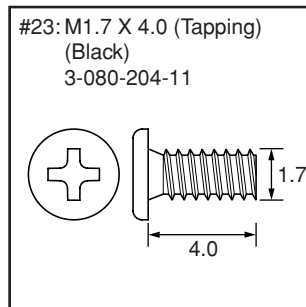
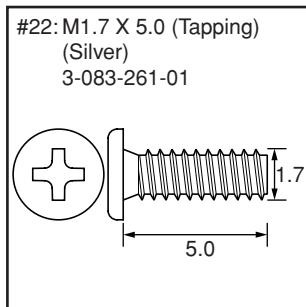
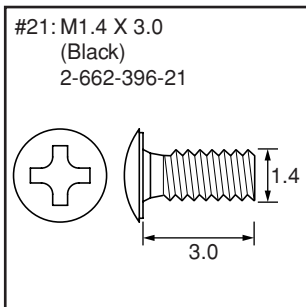

HARDWARE LIST (3/9)

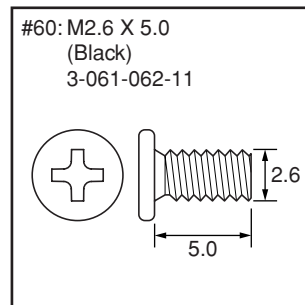
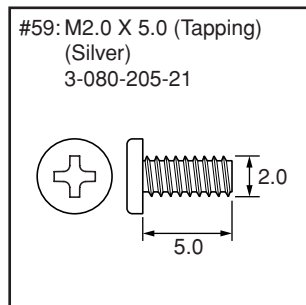
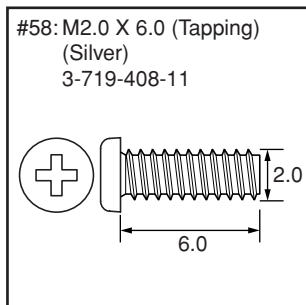
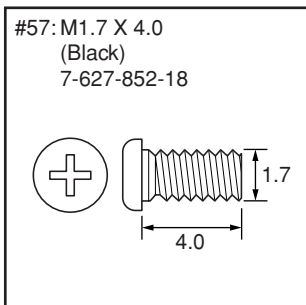
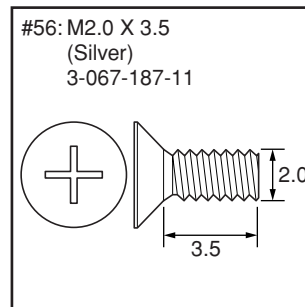
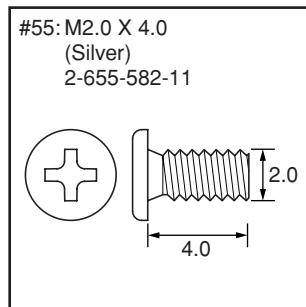
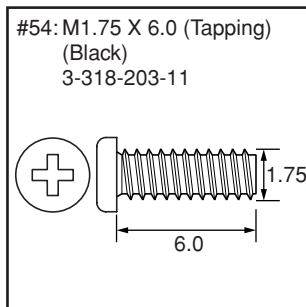
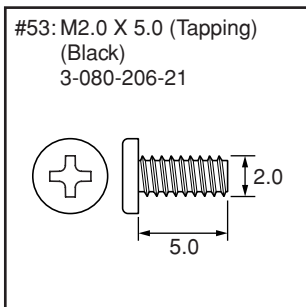
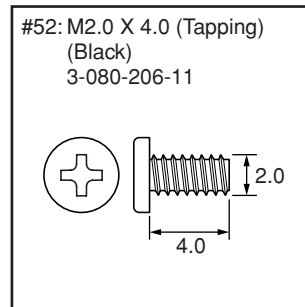
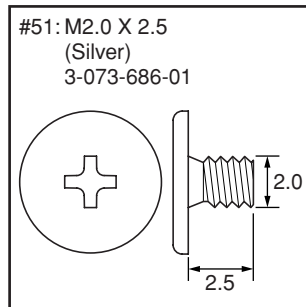
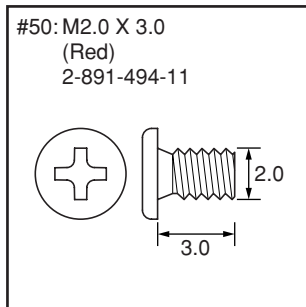
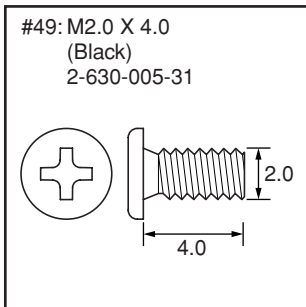
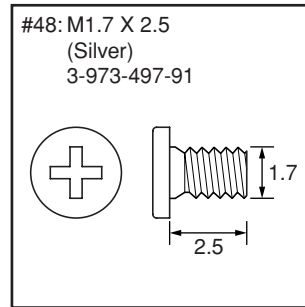
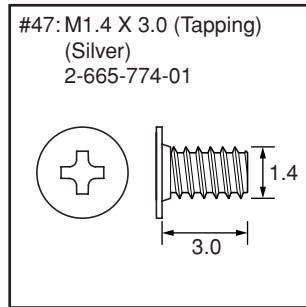
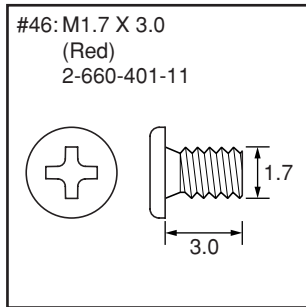
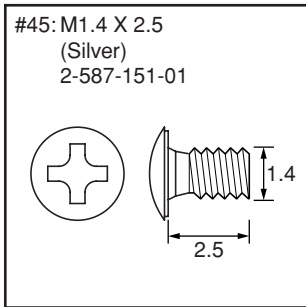
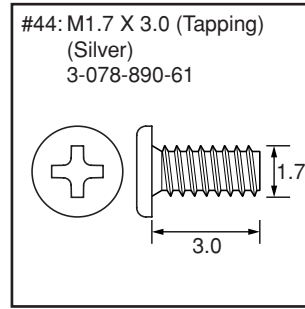
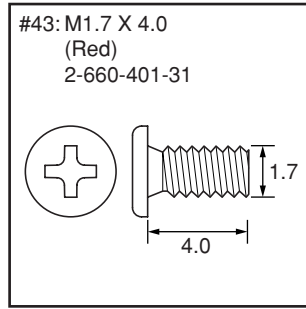
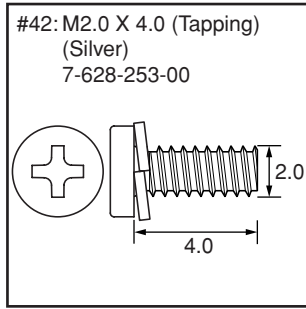
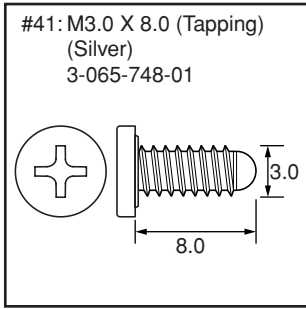

HARDWARE LIST (4/9)

#61: M3.0 X 10.0
(Black)
7-682-549-09

#62: M2.0 X 3.0
(Silver)
3-080-202-21

#63: M5.0 X 12.5
(Black)
3-060-811-21

#64: M1.7 X 5.0 (Tapping)
(Silver)
2-666-551-21

#65: M1.4 X 3.5
(Silver)
2-635-591-01

#66: M1.4 X 1.4
(Silver)
2-635-591-41

#67: M1.4 X 2.0
(Silver)
3-389-523-16

#68: M1.7 X 4.0
(Silver)
2-655-581-01

#69: M1.7 X 3.0
(Silver)
2-599-475-21

#70: M1.7 X 5.0
(Silver)
2-599-475-41

#71: M1.4 X 2.0
(Red)
3-208-537-01

#72: M1.4 X 2.0
(Silver)
4-663-621-41

#73: M1.2 X 4.0 (Tapping)
(Black)
3-086-156-61

#74: M1.7 X 6.0 (Tapping)
(Silver)
2-666-551-31

#75: M1.7 X 3.5 (Tapping)
(Silver)
2-666-551-01

#76: M1.7 X 4.0 (Tapping)
(Silver)
2-666-551-11

#77: M1.2 X 5.0 (Tapping)
(Silver)
3-086-156-31

#78: M1.4 X 3.5
(Red)
3-208-537-11

#79: M1.4 X 2.0
(Silver)
2-587-151-11

#80: M1.4 X 2.0
(Black)
3-279-411-01

HARDWARE LIST (5/9)

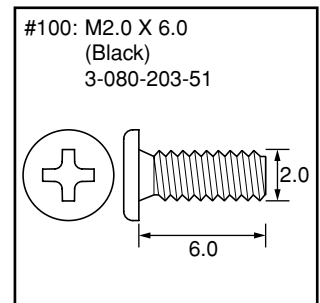
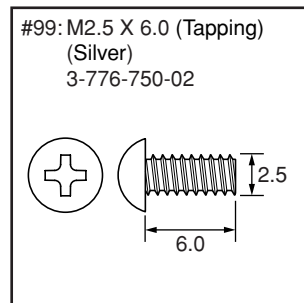
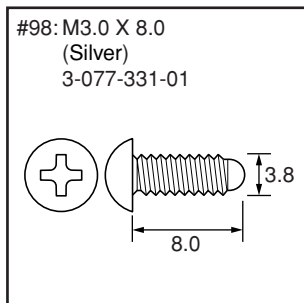
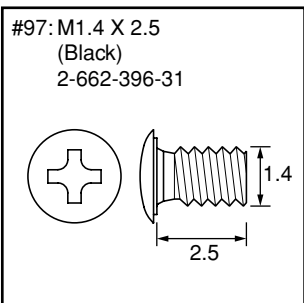
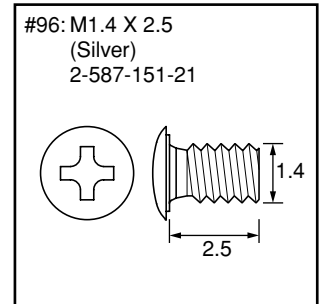
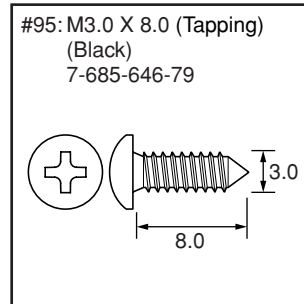
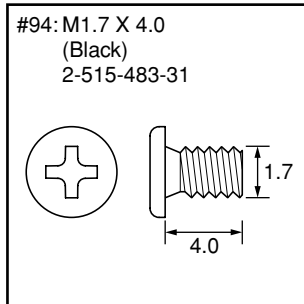
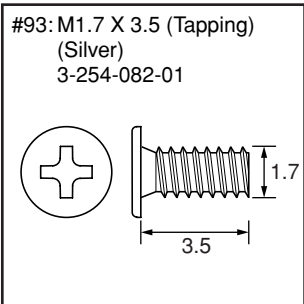
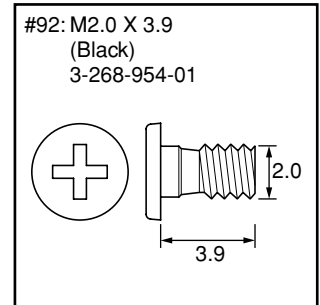
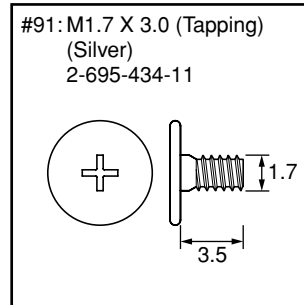
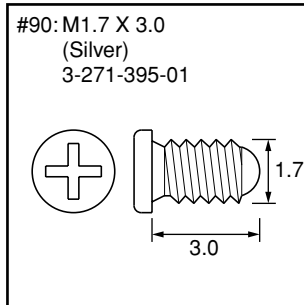
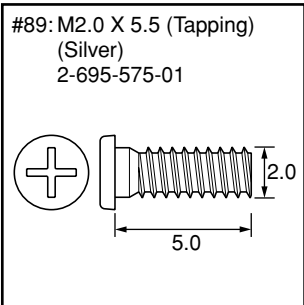
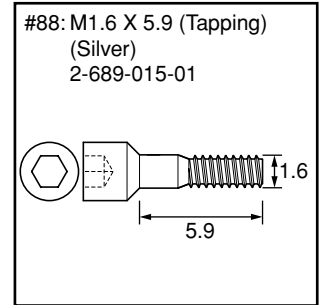
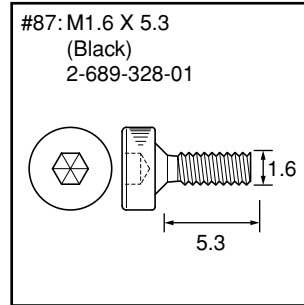
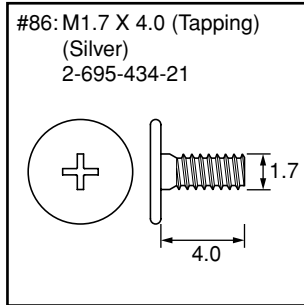
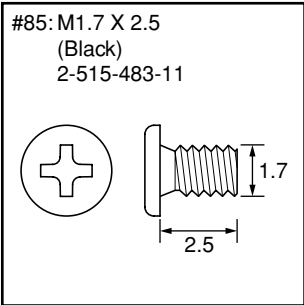
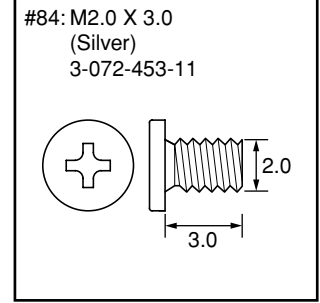
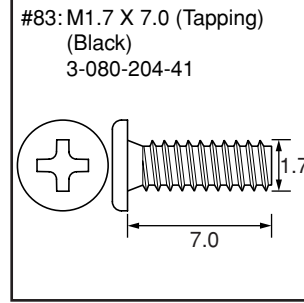
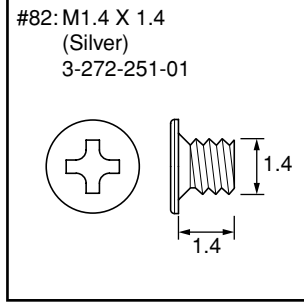
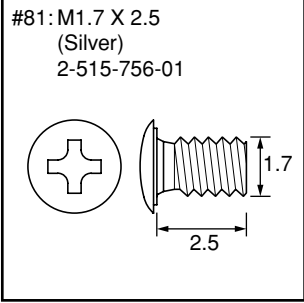

HARDWARE LIST (6/9)

#101: M2.0 X 5.0
(Silver)
7-621-555-39

#102: M2.6 X 8.0
(Black)
7-621-284-30

#103: M2.6 X 10.0
(Silver)
7-685-794-09

#104: M3.0 X 8.0
(Black)
7-682-548-09

#105: M2.0 X 4.0
(Red)
2-891-494-31

#106: M2.0 X 6.0
(Black)
3-713-786-11

#107: M2.0 X 5.0
(Silver)
3-032-750-01

#108: M1.7 X 3.0 (Tapping)
(Black)
2-695-430-01

#109: M1.7 X 3.0
(Black)
2-515-483-21

#110: M2.0 X 3.0
(Black)
2-630-005-21

#111: M1.7 X 4.0 (Tapping)
(Black)
2-887-124-01

#112: M1.4 X 5.0
(Black)
2-178-410-11

#113: M1.7 X 5.0
(Black)
2-635-562-41

#114: M2.0 X 5.5 (Tapping)
(Silver)
2-698-464-01

#115: M1.4 X 3.5 (Tapping)
(Silver)
3-348-998-51

#116: M2.0 X 3.5 (Tapping)
(Silver)
2-695-435-01

#117: M1.7 X 4.5 (Tapping)
(Silver)
2-695-429-31

#118: M1.4 X 2.0
(Black)
2-655-580-01

#119: M2.6 X 5.0
(Black)
7-627-556-58

#120: M2.6 X 6.0
(Silver)
7-621-770-67

HARDWARE LIST (7/9)

#121: M2.0 X 4.0 (Tapping)
(Silver)
3-080-205-11

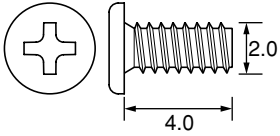

#122: M3.0 X 6.0
(Black)
7-682-547-09

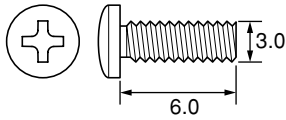

#123: M4.0 X 8.0
(Black)
7-682-561-09

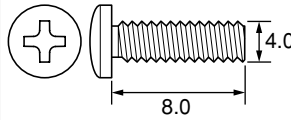

#124: M1.7 X 2.0
(Silver)
2-599-475-01

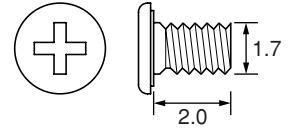

#125: M1.4 X 3.0
(Black)
3-291-847-01

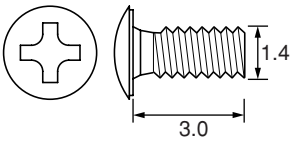

#126: M2.9 X 3.5
(Black)
3-292-616-01

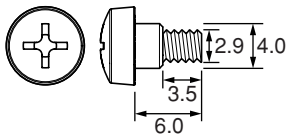

#127: M3.0 X 25.0
(Black)
7-682-654-09

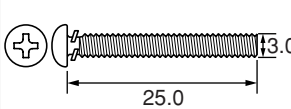

#128: M4.0 X 12.0
(Black)
3-452-472-01

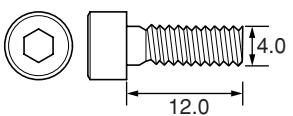

#129: M3.0 X 12.0
(Black)
7-682-550-09

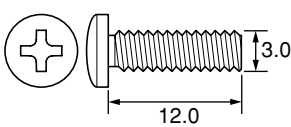

#130: M2.0 X 4.5 (Tapping)
(Silver)
3-732-817-11

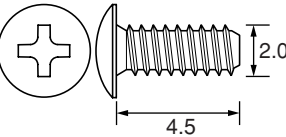

#131: M4.0 X 12.0
(Silver)
3-452-471-01

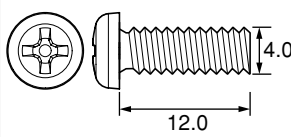

#132: M2.6 X 6.0
(Black)
4-673-655-01

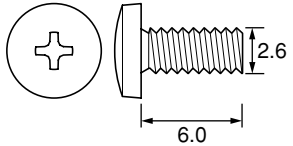

#133: M3.0 X 6.0
(Black)
3-452-484-01

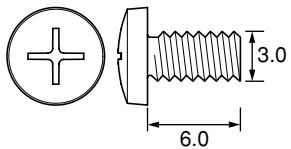

#134: M2.6 X 7.0
(Black)
3-299-572-01

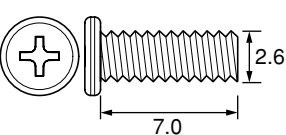

#135: M2.0 X 2.5
(Black)
7-627-553-28

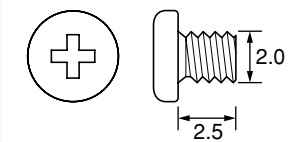

#136: M1.4 X 4.0 (Tapping)
(Black)
3-065-509-11

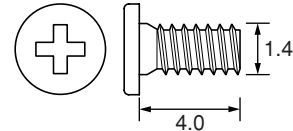

#137: M1.7 X 3.0
(Black)
3-090-976-62

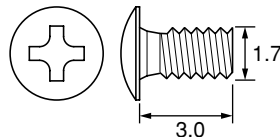

#138: M1.4 X 3.5
(Silver)
4-104-078-01

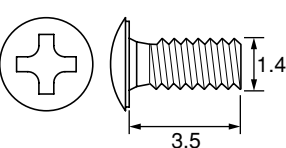

#139: M1.4 X 2.0
(Silver)
2-655-579-01

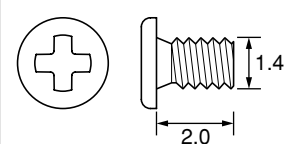

#140: M1.7 X 2.0
(Black)
2-635-562-01

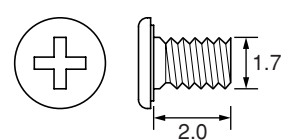

HARDWARE LIST (8/9)

#141: M2.6 X 5.0 (Tapping)
(Silver)
7-685-791-01

#142: M1.4 X 2.0
(Silver)
4-111-392-01

#143: M1.4 X 2.0
(Black)
4-111-392-11

#144: M1.4 X 1.2
(Silver)
4-111-392-21

#145: M1.4 X 2.4
(Silver)
4-111-248-01

#146: M1.4 X 2.4
(Black)
4-111-248-11

#147: M1.4 X 3.5
(Black)
2-662-396-41

#148: M1.7 X 3.0
(Silver)
3-057-082-21

#149: M1.6 X 7.5 (Tapping)
(Silver)
4-115-505-01

#150: M1.4 X 3.0
(Black)
4-105-150-01

#151: M1.4 X 1.4
(Silver)
3-272-251-11

#152: M1.4 X 2.5
(Black)
4-116-473-11

#153: M1.4 X 1.5
(Silver)
3-059-718-01

#154: M2.6 X 8.0
(Silver)
7-627-556-97

#155: M1.7 X 6.0 (Tapping)
(Black)
3-080-204-31

#156: M1.4 X 4.0
(Silver)
2-635-591-61

#157: M1.7 X 5.0 (Tapping)
(Black)
4-132-562-01

#158: M1.7 X 5.0
(Red)
2-660-401-51

#159: M1.4 X 4.0
(Black)
2-662-396-51

#160: M1.4 X 3.0
(Silver)
4-139-851-01

HARDWARE LIST (9/9)

#161: M1.4 X 3.0
(Black)
4-139-852-01

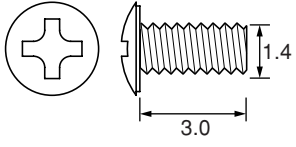

Revision History

*: S.M. revised only top cover.

Ver.	Date	History	Contents	S.M. Rev. issued
1.0	2009.03	Official Release	—	—
1.1	2009.04	Revised-1 (A1 09-006)	<ul style="list-style-type: none"> • Correction of Block Diagrams • Correction of Schematic Diagram • Correction of Printed Wiring Board • Correction of Repair Parts List S.M. revised: Page 3-1 , Page 3-3 , Page 4-18 , Page 4-27 , Page 5-4 , Page 5-6 , Page 5-10 , Page 5-11	Yes
1.2	2009.08	Supplement-1 (S1 09-183)	<ul style="list-style-type: none"> • Change of Repair Parts 	Yes*