



Service Manual

FROID AMERICAIN

S20D RSS33-A/G

MODELE VERSION		Page
S20D RSS33-A/G 8586 158 01031		
	DONNEES TECHNIQUES	2
	LISTE DE PIECES	3 - 4
	VUE ECLATEE	5 - 15
	SCHEMAS DE PRINCIPE ET DE CABLAGE	16 - 17

**R o H S**

DONNEES TECHNIQUES

NO DE FABRICATION

SB 540 W

DIMENSIONS

HAUTEUR	178,0	cm
LARGEUR	90,2	cm
PROFONDEUR	77,7	cm

VOLUME

TOTAL

BRUT	546	l
NET	490	l

REFRIGERATEUR

BRUT	340	l
NET	335	l

CONGELATEUR

BRUT	206	l
NET	133	l

RACCORDEMENT ELECTRIQUE

TENSION	220 - 240	V
FREQUENCE	50	Hz

CONSOMMATION D'ENERGIE

EN 24 HEURES	1,37	kWh
--------------	------	-----

POUVOIR DE CONGELATION

EN 24 HEURES	12	kg
--------------	----	----

COMPRESSEUR

TYPE	EGY 90 HLC CP	
PUISSANCE	174	W

REFRIGERANT

TYPE	R 134 a	
QUANTITE	160	g

THERMOSTATS

A CONTROLE ELECTRONIQUE

DEBIT MAXI DE GLACE ET GLACONS

EN 24 HEURES	2,3	kg
--------------	-----	----

LISTE DE PIECES

Model **S20D RSS33-A/G**
Service No. **858615801031**
Version **858615801031**

Pos. No.	Code 12NC	Description	Pos. No.	Code 12NC	Description
012 1	4812 528 78061	ROULETTE ARRIERE	241 1	4812 458 19112	PANIER INF. CONG.
012 3	4812 528 78059	ROULETTE AVANT REGLABLE	241 3	4812 440 69202	VOLET TRANSP. PANIER CONG.
012 4	4812 310 68021	KIT CLEF REGLAGE ROULETTES	241 5	4812 460 49285	ENJOLIVEUR PANIER CONG.
033 7	4812 459 48188	COUVERCLE SxS	242 0	4812 418 28365	TIROIR INF. REF LEGUMES
040 0	4812 417 19245	CHARNIERE SUP.	242 1	4812 418 28363	TIROIR SUP. REF.
040 1	4812 417 19246	CHARNIERE SUP.	242 3	4812 418 28364	TIROIR MILIEU REF.
040 2	4812 417 19261	CHARNIERE	245 5	4812 458 19108	GRILLE SUP. CONG.
040 4	4812 417 19262	CHARNIERE	245 6	4812 458 19109	GRILLE INF. CONG.
040 6	4812 417 19102	SUPPORT PLINTHE REGLABLE	245 8	4812 458 19111	PANIER SUP. CONG.
040 7	4812 417 78101	CACHE CHARNIERE	245 9	4812 440 79143	BAC COLLECT.
040 8	4812 417 78102	CACHE CHARNIERE	249 0	4812 460 49286	ENJOLIVEUR TIROIR SUP. REF.
047 0	4819 021 82178	BUTEE INF. DE PORTE REF.	249 1	4812 460 49283	ENJOLIVEUR SUP. GRILLE CONG.
047 1	4812 532 48035	BUTEE INF. DE PORTE CONG.	249 2	4812 460 49284	ENJOLIVEUR PANIER SUP. CONG.
047 2	4812 440 29448	COUVERCLE	249 3	4812 460 49287	ENJOLIVEUR TIROIR MILIEU REF.
047 4	4812 462 28564	PION	249 4	4812 460 49282	ENJOLIVEUR ARR. PLAQUE VERRE
070 0	4812 440 89068	PLINTHE	249 9	4812 460 49288	ENJOLIVEUR BALCONNET REF.
084 3	4812 404 18386	CAOUTCHOUC MOTEUR VENTIL.	251 1	4812 440 98122	COUVERCLE LAMPE REF.
101 0	4812 416 19399	PORTE CONGEL.	251 4	4812 404 18387	JOINT LAMPE DISTRIB.
104 0	4812 416 19401	PORTE REFRIG.	251 8	4812 380 28033	COUVERCLE LAMPE
105 4	4812 535 38099	ETRIER INF. REF. / CONG.	251 9	4812 440 98125	COUVERCLE LAMPE CONG.
111 0	4812 462 68842	POIGNEE PORTE	252 0	4812 310 28188	MODULE CONTROLE LAMPE
111 2	4812 462 28493	EMBOUT INF. POIGNEE REF./CONG	252 5	4812 442 29279	CONVOYEUR
111 3	4812 462 28428	EMBOUT SUP. POIGNEE REF./CONG.	255 1	4812 450 88094	CLAYETTE VERRE REF. CPL.
111 4	4812 462 28426	SUPPORT POIGNEE REF. / CONG.	255 4	4812 450 88095	CLAYETTE VERRE BAC LEGUMES
111 5	4812 462 28482	CACHE SUPPORT POIGNEE	255 5	4812 450 88096	CLAYETTE VERRE BAC SUP.
111 7	4812 459 18218	PLAQUE SIGLE WP	255 7	4812 418 28359	CADRE CLAYETTE VERRE INF.
131 0	4812 460 48968	LEVIER EAU FRAICHE	255 8	4812 418 28361	CADRE CLAYETTE VERRE BAC SUP.
131 1	4812 460 48967	LEVIER CDE GLACONS	255 9	4812 418 28362	CADRE CLAYETTE VERRE INF.
131 2	4812 440 69307	PORTILLON	256 0	4812 460 58384	CURSEUR REGUL. AIR
131 3	4819 021 80224	GUIDE GLACONS	256 5	4819 466 98997	SUPPORT CURSEUR AIR BAC REF.
131 4	4812 440 69075	MECANISME DISTRIB. GLACON	261 0	4812 462 38139	GLISSIERE INF. DROITE CONG.
131 7	4819 021 80223	RETARDATEUR	261 1	4812 462 38138	GLISSIERE GAUCHE CONG.
131 8	4819 021 80210	AXE RESSORT CHARNIERE LEVIER	263 6	4812 462 38155	GLISSIERE SUP. DROITE CONG.
151 0	4812 488 68139	PROFILE PORTE	263 7	4812 460 98041	GLISSIERE SUP. GAUCHE CONG.
152 2	4812 418 28366	BALCONNET PORTE CONG.	263 8	4812 404 48702	PION SUPPORT CLAYETTE
153 0	4812 418 28371	PORTILLON DE BALCONNET REF.	263 9	4812 404 48701	PION AVANT G SUPPORT CLAYETTE
153 3	4812 418 28372	BALCONNET BOUTEILLES REF.	304 0	4812 418 88995	SUPPORT LEVIER ET COMP. ELECT.
154 0	4812 418 28421	BALCONNET LARGE PORTE REF.	320 0	4812 452 28774	BANDEAU
154 1	4812 418 28748	SEPARATEUR	324 6	4812 442 29303	CONVOYEUR D'AIR
154 2	4812 404 78552	DOUILLE PORTILLON	400 0	4812 028 58363	MOTEUR CONVOYEUR GLACE
154 3	4812 462 28478	PION BALCONNET	402 0	4812 360 38812	COMPRESSEUR EGY 90 HLC CP
154 4	4812 418 28373	TIGE BOUTEILLES BALCON. LARGE	402 1	4812 418 28378	BAC DEGIVRAGE
154 6	4812 418 28376	TIGE BOUTEILLES BALCON. ETROIT	402 2	4819 360 48014	CLAPET ANTI-RETOUR
154 9	4812 418 28422	BALCONNET ETROIT PORTE REF.	402 4	4812 440 79129	CLIP
155 0	4812 418 28754	GALERIE OEUFS	406 2	4812 440 89009	COUVERCLE FAB. DE GLACONS
191 0	4812 466 88644	JOINT MAGNET. PORTE REF.	406 3	4812 492 98044	RESSORT
191 1	4812 466 88645	JOINT MAGNET. PORTE CONG.	406 7	4812 440 79023	FOND DISTRIBUTEUR
201 7	4819 466 69949	JOINT CARTER MOTEUR VENTILAT.	406 8	4812 530 88024	ARBRE DE TRANSM. CONVOYEUR
233 2	4812 404 48697	SUPPORT CLAYETTE CONG.	407 0	4812 404 78554	FIXATION EMBRAYAGE DISTRIB.
239 2	4812 440 98124	SUPPORT FACADE FAB. GLACE	407 1	4812 310 28142	DOUILLE EMBRAYAGE DISTRIB.
239 4	4812 440 69204	FACADE FABRIQUE GLACONS	420 0	4812 120 28023	CONDENSATEUR
239 5	4812 418 29716	FAB. DE GLACONS	420 4	4812 442 29019	CACHE PROTEGE TUBE
239 7	4812 418 28758	CUVE	437 0	4812 218 48133	EMETTEUR CPL. FAB. GLACONS
239 8	4812 418 28433	DISTRIBUT. GLACONS/GLACE PILEE	438 0	4812 217 28003	RECEPTEUR
241 0	4812 458 19113	GRAND PANIER CARRE CONG.	440 3	4812 361 38103	CONVOYEUR D'AIR

LISTE DE PIECES**Model** S20D RSS33-A/G
Service No. 858615801031
Version 858615801031

Pos. No.	Code 12NC	Description
440 4	4812 462 38141	GLISSIERE REGUL. D'AIR
440 5	4812 445 28036	CONVOYEUR D'AIR
440 6	4819 462 38778	CURSEUR REGUL. D'AIR
440 7	4812 452 98237	ISOLATION CONDENSEUR
440 8	4812 440 79136	PORTILLON
441 0	4812 028 58339	MOTEUR VENTILATEUR
441 1	4819 462 48418	AMORTISSEUR COMPRESSEUR
441 2	4812 440 68962	COTES CARTER VENTILATEUR G+D
442 0	4812 361 38119	MOTEUR VENTIL.
442 1	4819 404 78682	SUPPORT MOTEUR VENTIL.
443 0	4819 515 48057	TURBINE VENTILATEUR
443 1	4819 021 82120	CARTER MOTEUR VENTILATEUR
451 0	4819 021 88177	RESISTANCE DE DEGIVRAGE
451 1	4812 401 18807	AGRAPHES
491 0	4812 290 88087	COUVERCLE BLOC CONNEXIONS
526 2	4812 217 78217	PLATINE CONTROL
526 5	4812 440 29368	COUVERCLE PLATINE DE CONTR.
561 2	4812 290 68324	BORNIER
562 0	4812 320 58132	CABLES EVAPO. + TH. BI-METAL
571 0	4812 360 58486	ELECTROVANNE ARRIVEE D'EAU
614 0	4812 280 28039	PTC-UNIT
620 1	4812 277 88002	INTER. DISTRIBUTEUR
620 4	4819 276 18157	INTER. LUMIERE REF / CONG.
621 0	4819 271 38044	INTER. SELECTION DISTRIBUTEUR
626 1	4812 440 79112	DEFLECTEUR
643 0	4812 215 38013	THERMOMETRE SPACE 4-SxS
651 0	4812 134 28078	LAMPE CONGEL. / REFRIG.
651 2	4812 134 28077	LAMPE DISTRIBUTEUR
652 4	4819 021 80200	DOUILLE DE LAMPE DISTRIB.
691 3	4812 404 78553	SUPPORT SONDE CONGEL.
691 4	4812 210 58053	COUVERCLE
691 5	4812 404 78706	SUPPORT
691 7	4812 310 18846	KIT SONDE
701 0	4812 526 48179	COUPLEUR
711 0	4812 530 28999	TUYAU RESERVOIR D'EAU
740 0	4812 511 38215	CONDENSEUR
743 0	4812 440 89103	GRILLE D'AERAT.
743 3	4812 466 88722	JOINT
745 0	4812 360 38648	EVAPORATEUR
745 2	4812 440 29446	COUVERCLE
745 4	4819 492 68684	CLIP EVAPORATEUR
745 6	4812 440 79113	BUCLIER TERMIC
746 1	4812 440 98225	CONVOYEUR
746 2	4812 440 69203	COUVERCLE BAS GUIDE D'AIR
746 3	4812 440 98062	GRAND JOINT GUIDE D'AIR
764 2	4812 480 28092	DESHYDRATEUR
781 0	4812 262 78009	BOUCHON FILTRE A EAU
781 1	4812 535 48013	RACCORD D'ETANCHEITE
781 3	4812 530 29412	RACCORD TUYAU 3/4"
781 8	4812 817 29632	FILTRE
781 9	4812 418 28379	CORPS DE FILTRE
783 1	4812 360 68624	TUYAU
783 8	4812 530 29159	TUBE EAU / FILTRE
783 9	4812 530 29158	TUBE RACCORD FILTRE
785 0	4812 530 29348	TUBE

Pos. No.	Code 12NC	Description
900 5	4819 492 68544	BAGUE FIXATION TUBE A EAU
900 7	4819 492 68683	CLIP THERMOSTAT
900 8	4819 492 69522	CLIP CONDUIT D'AIR
910 9	4819 532 28199	ECROU
911 7	4819 505 18256	ECROU DE BLOCAGE TUBE
912 4	4812 560 18067	VIS
913 2	4812 560 18013	VIS SUPPORT
913 4	4812 500 18109	VIS
913 5	4812 500 18108	VIS
913 7	4812 502 18578	VIS SUPPORT PLAQUE
930 0	4812 492 28217	RESSORT
930 1	4819 021 94719	RAIL GUIDE
930 2	4812 418 88043	SERRE CABLE
962 1	4812 460 49343	SUPPORT
965 6	4812 462 28664	PION

VUE ECLATEE

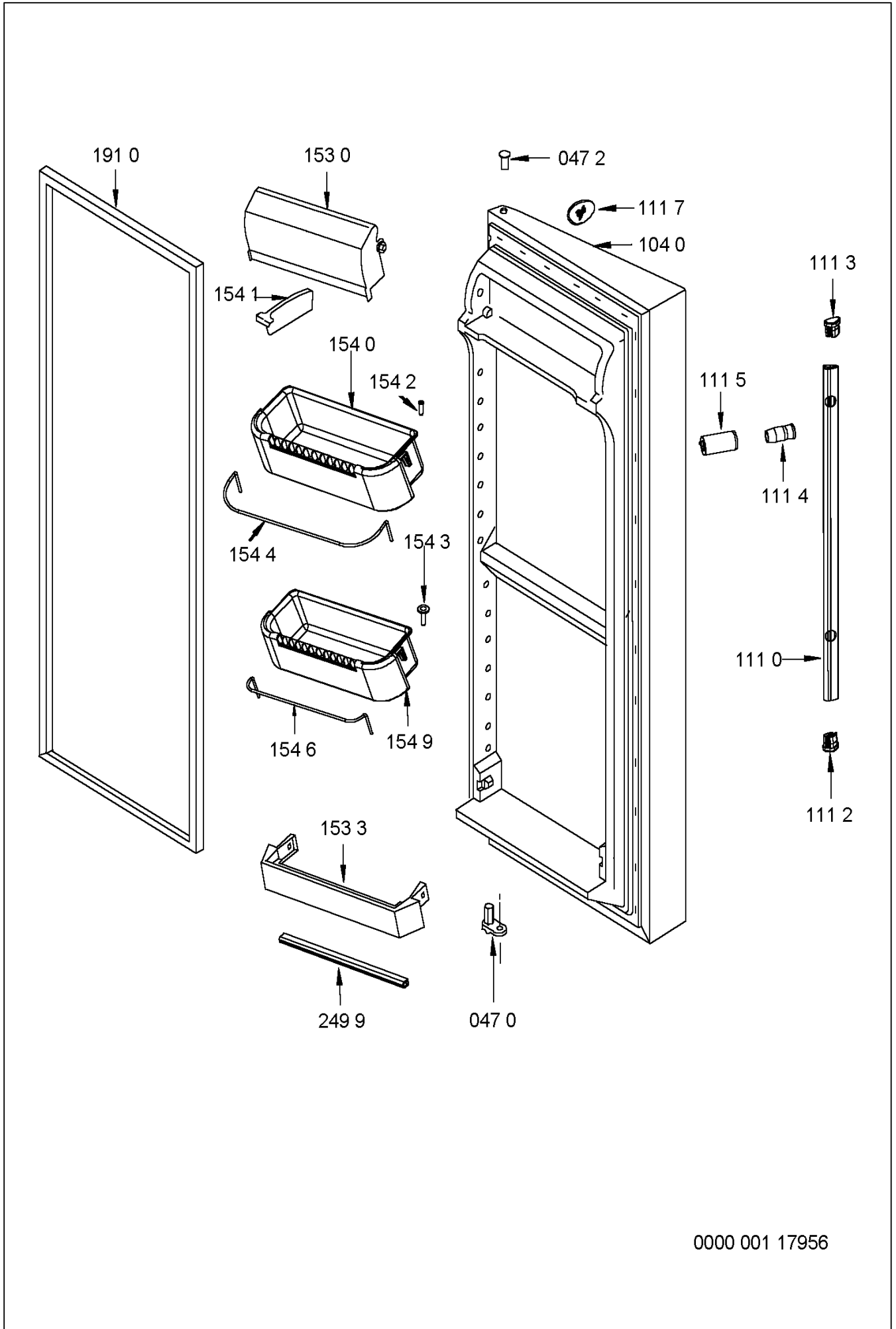

VUE ECLATEE

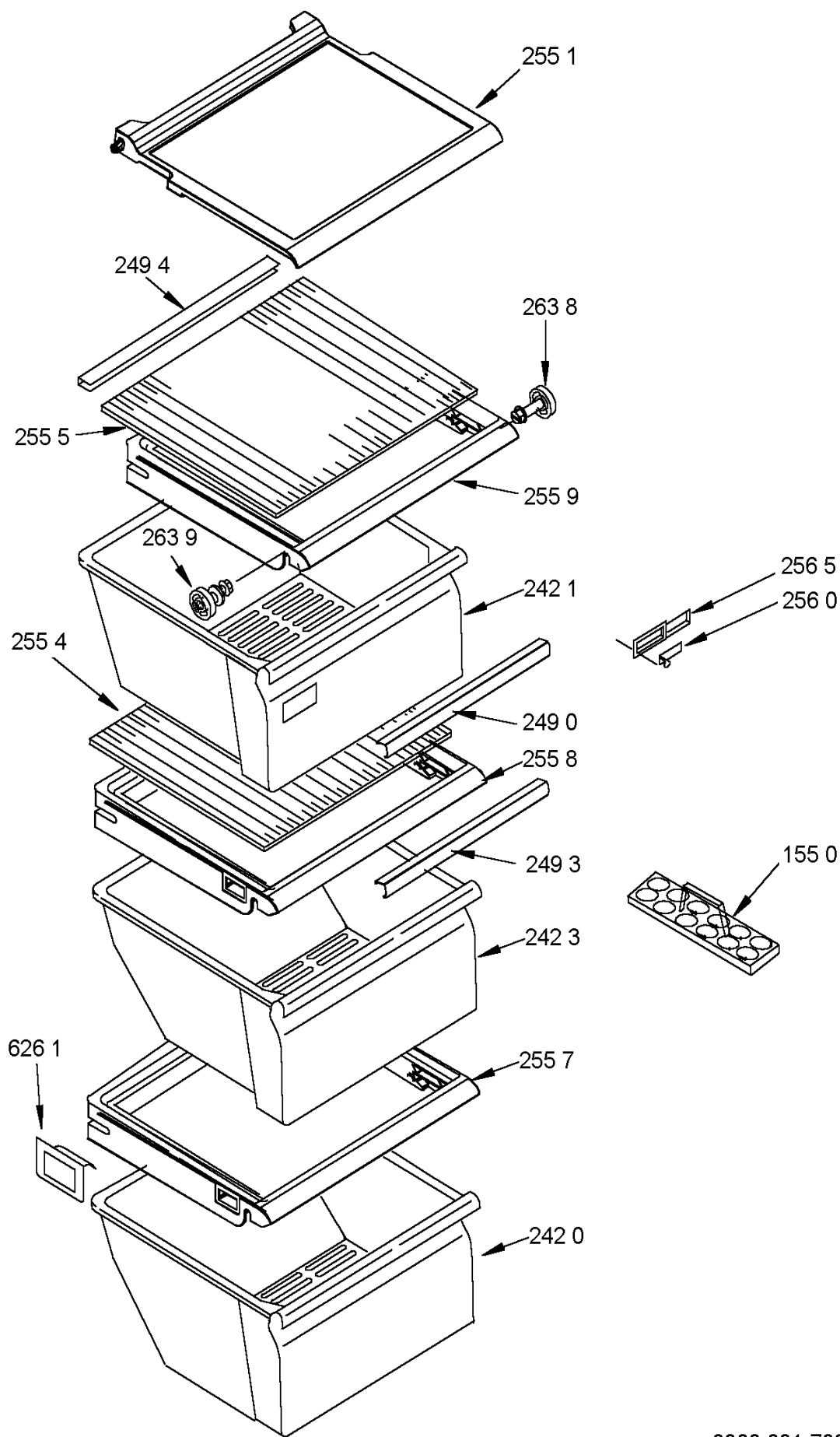

VUE ECLATEE

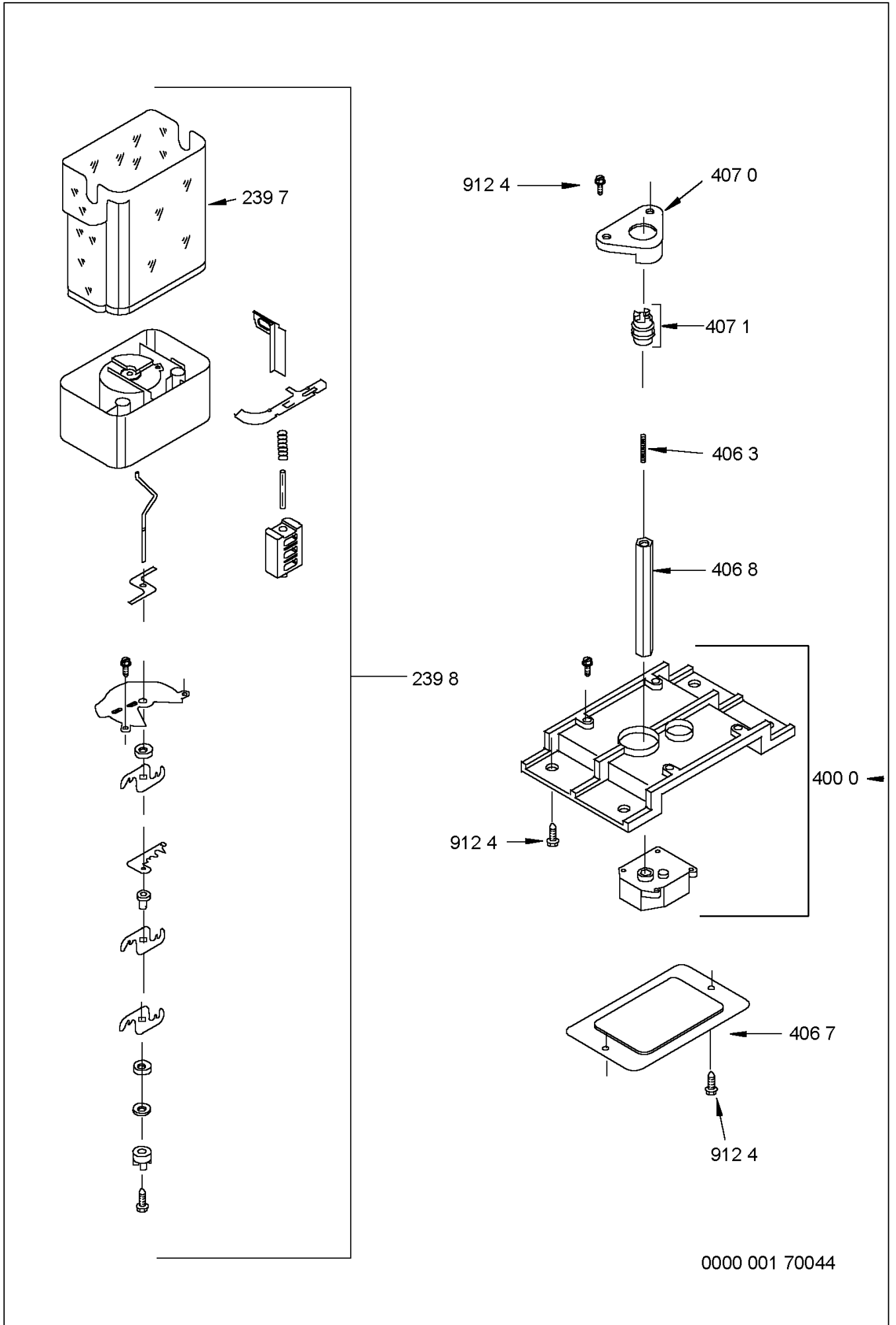

VUE ECLATEE

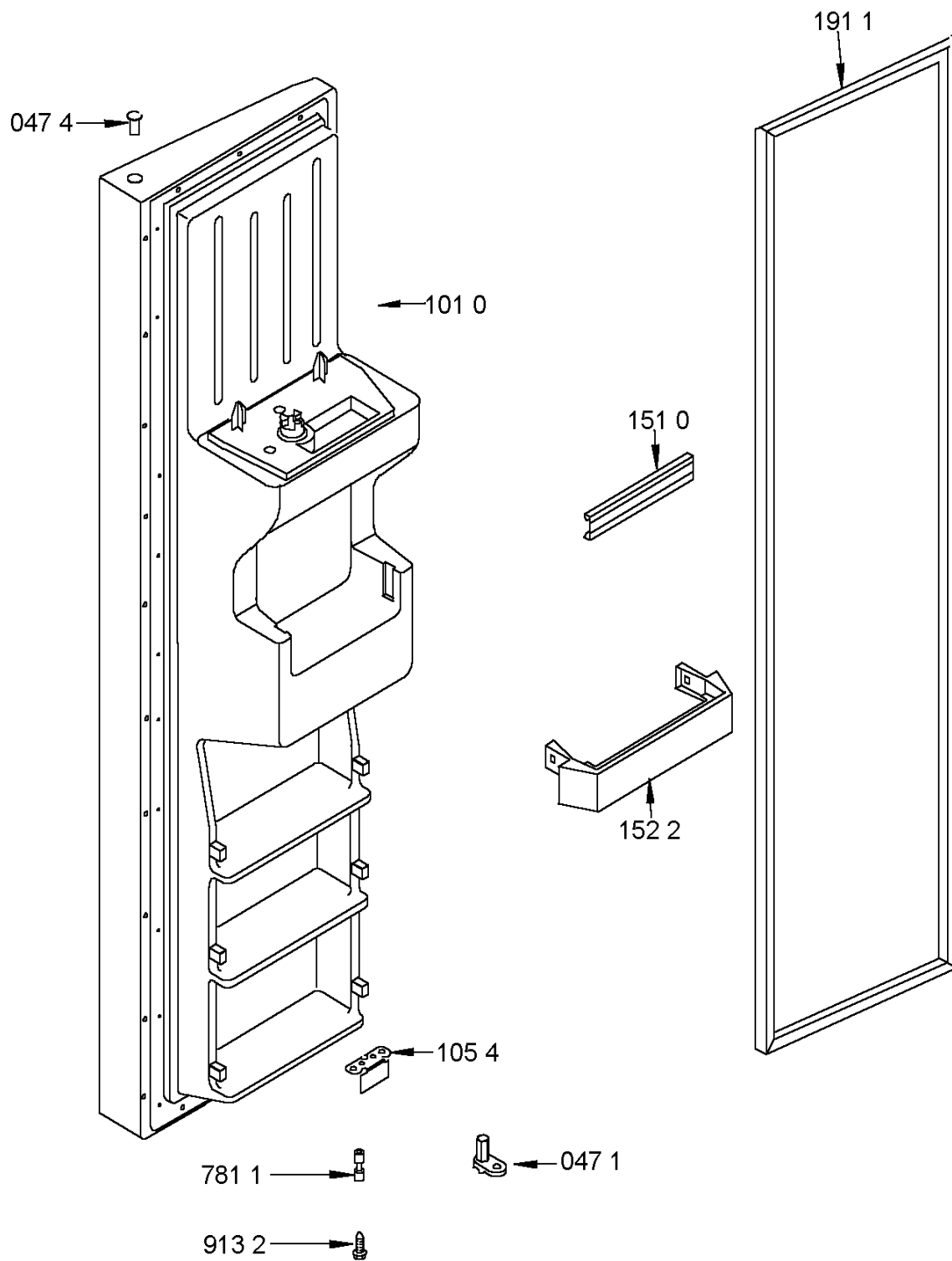

0000 001 70190

VUE ECLATEE

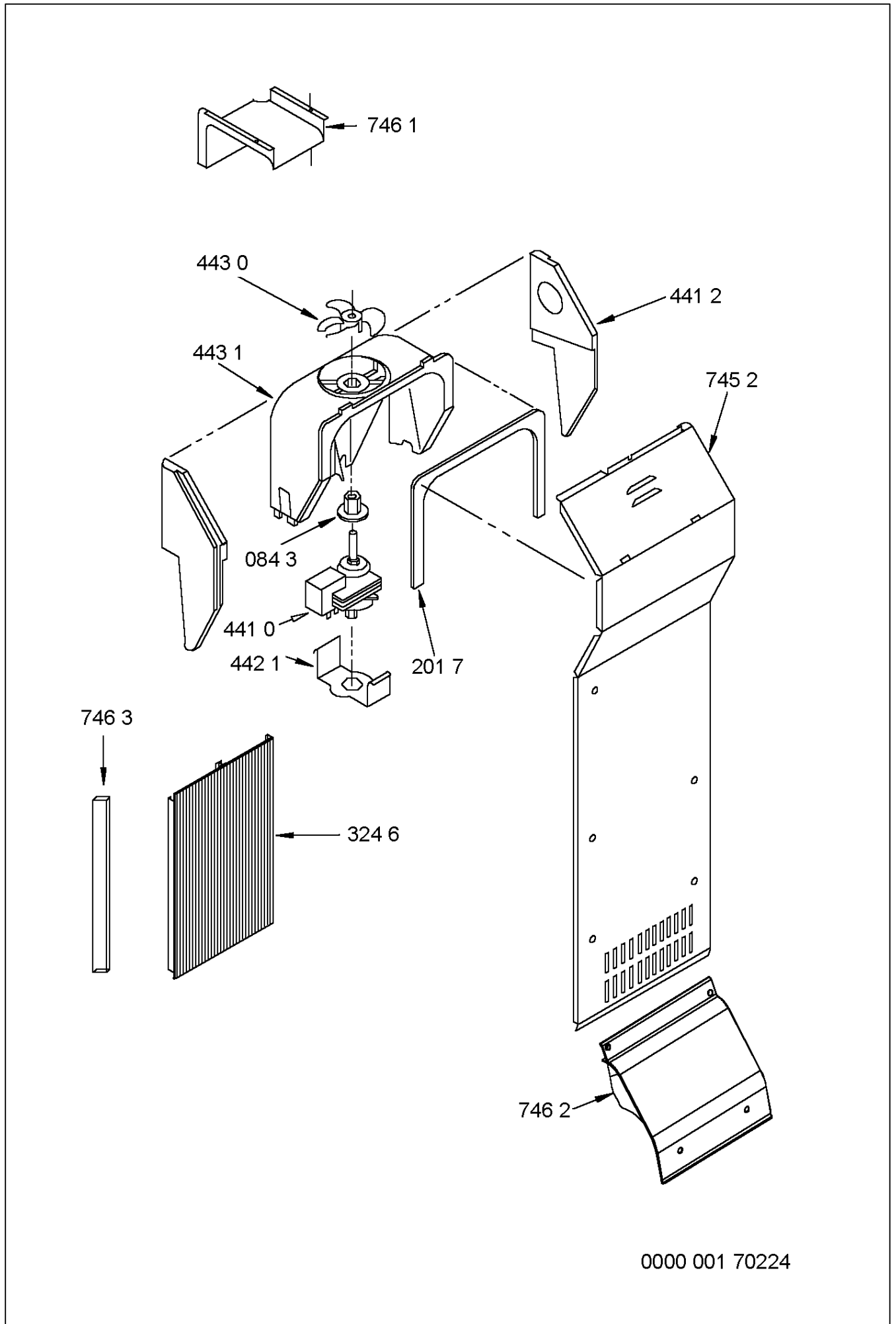

0000 001 70224

VUE ECLATEE

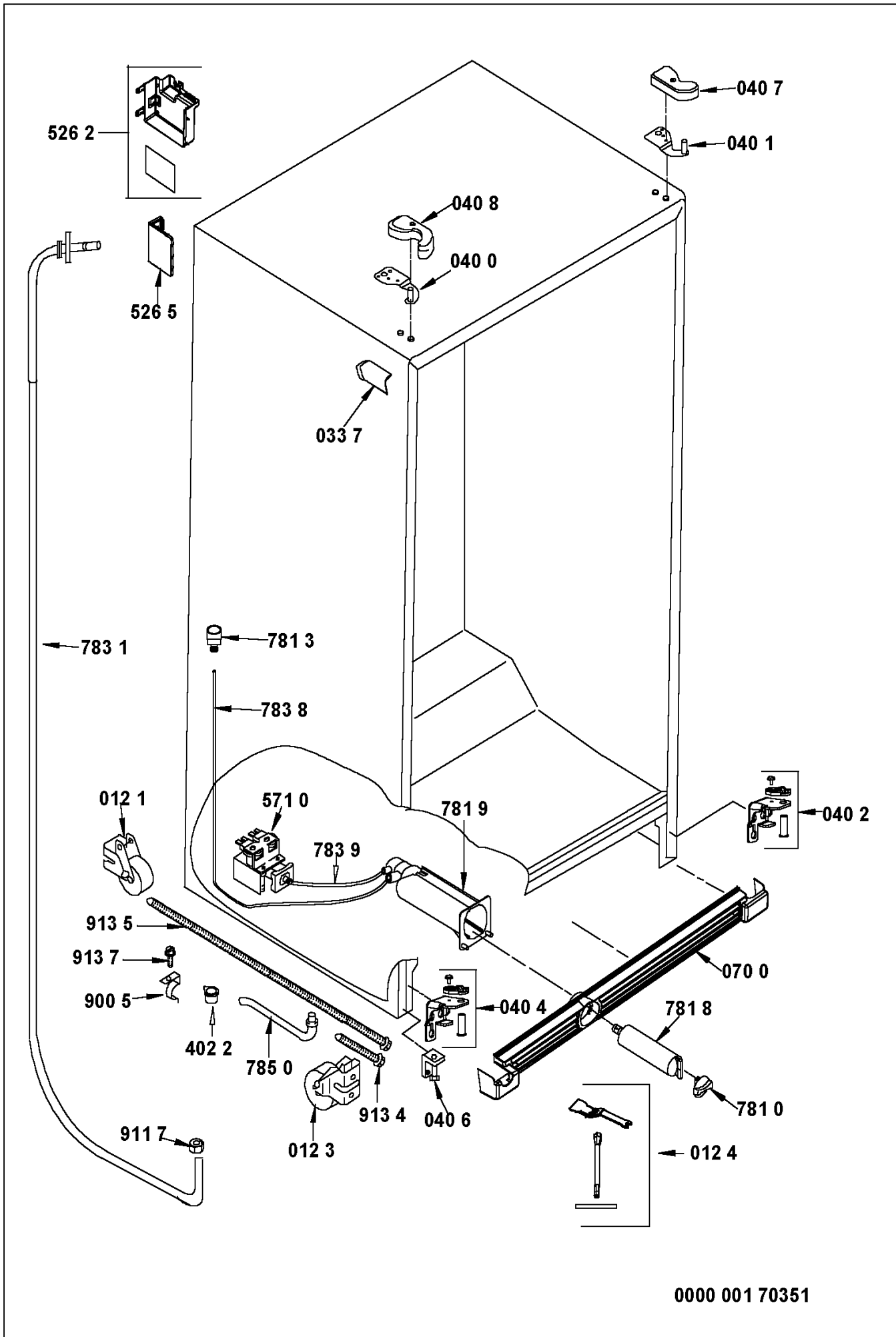

VUE ECLATEE

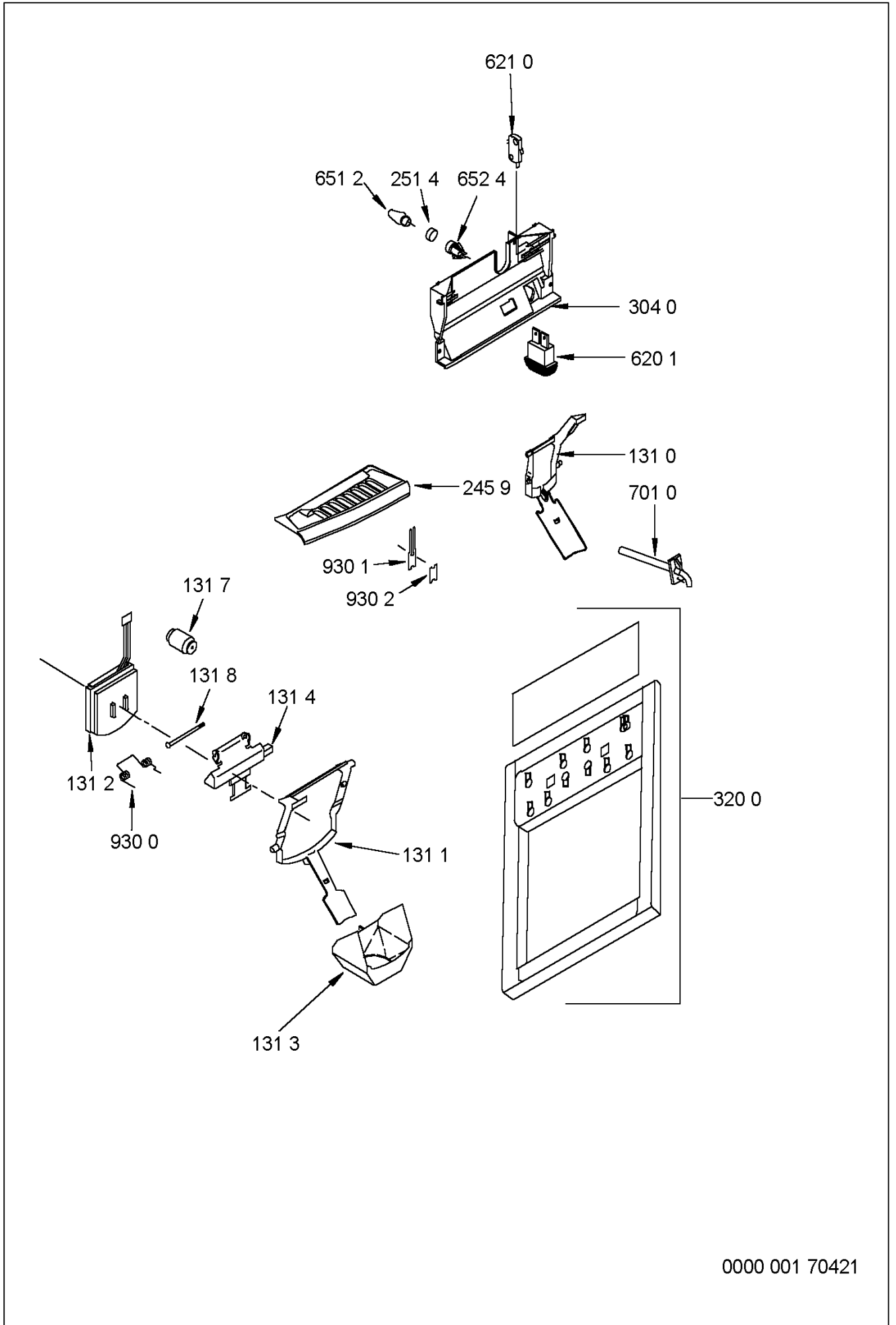

VUE ECLATEE

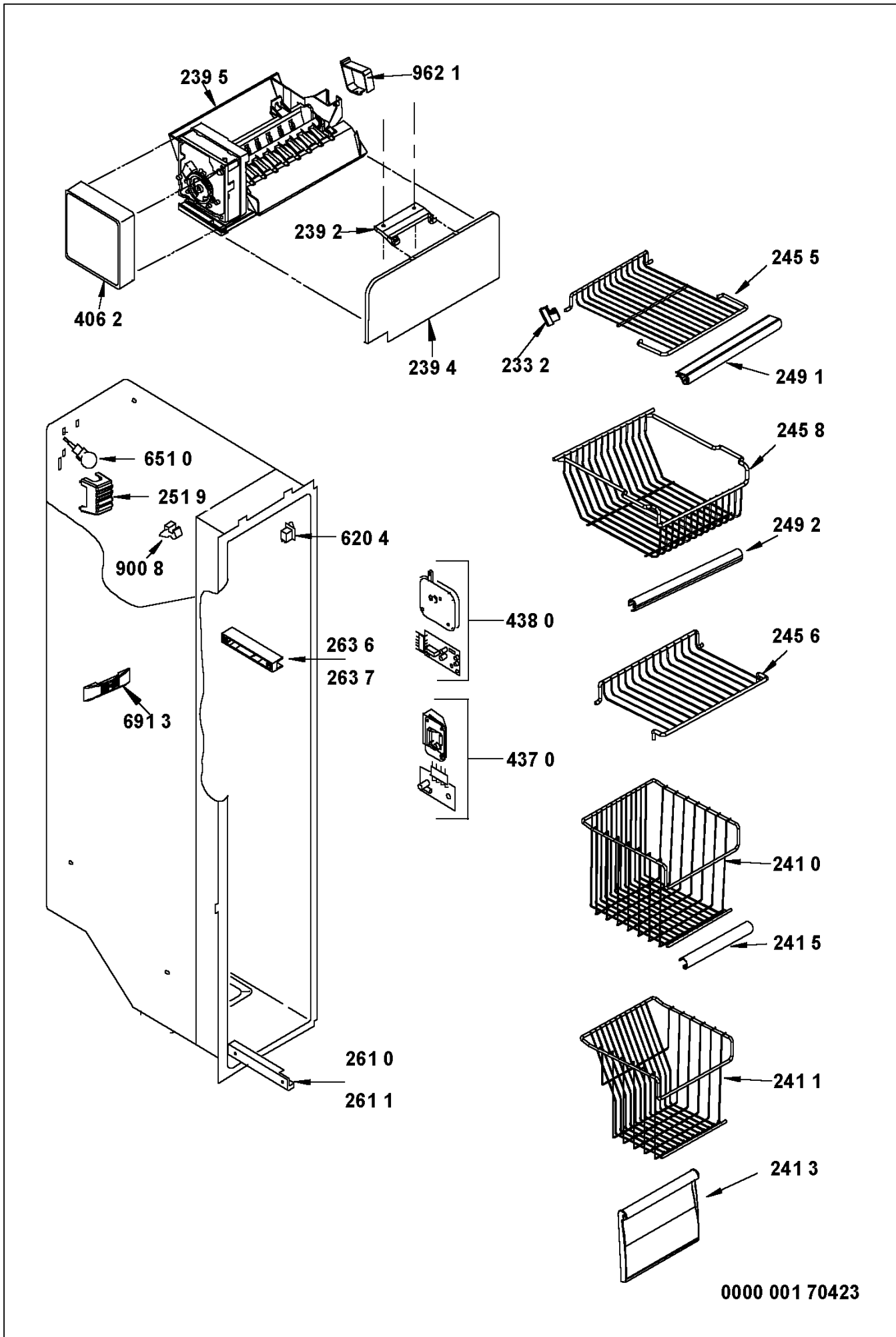

0000 001 70423

VUE ECLATEE

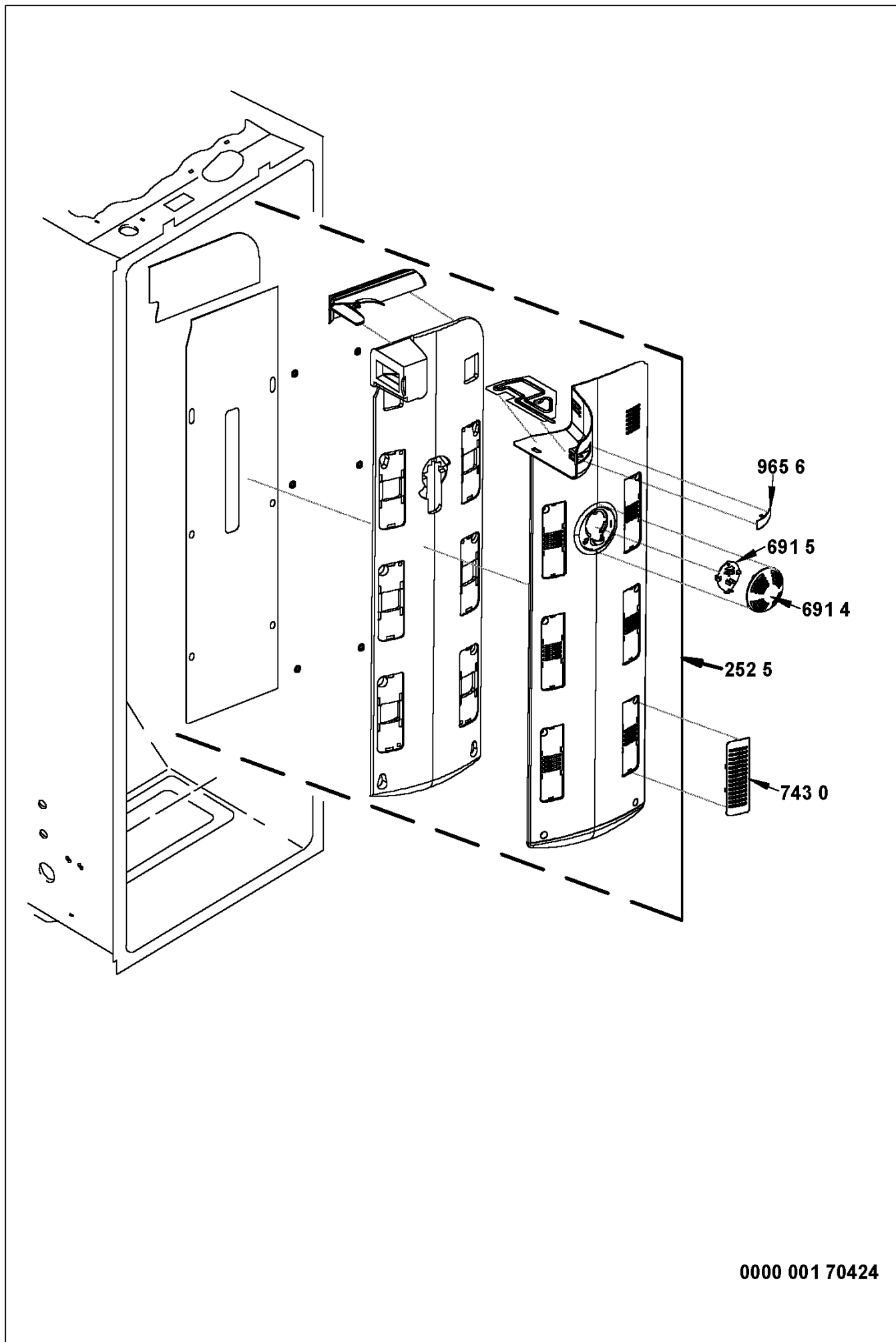

VUE ECLATEE

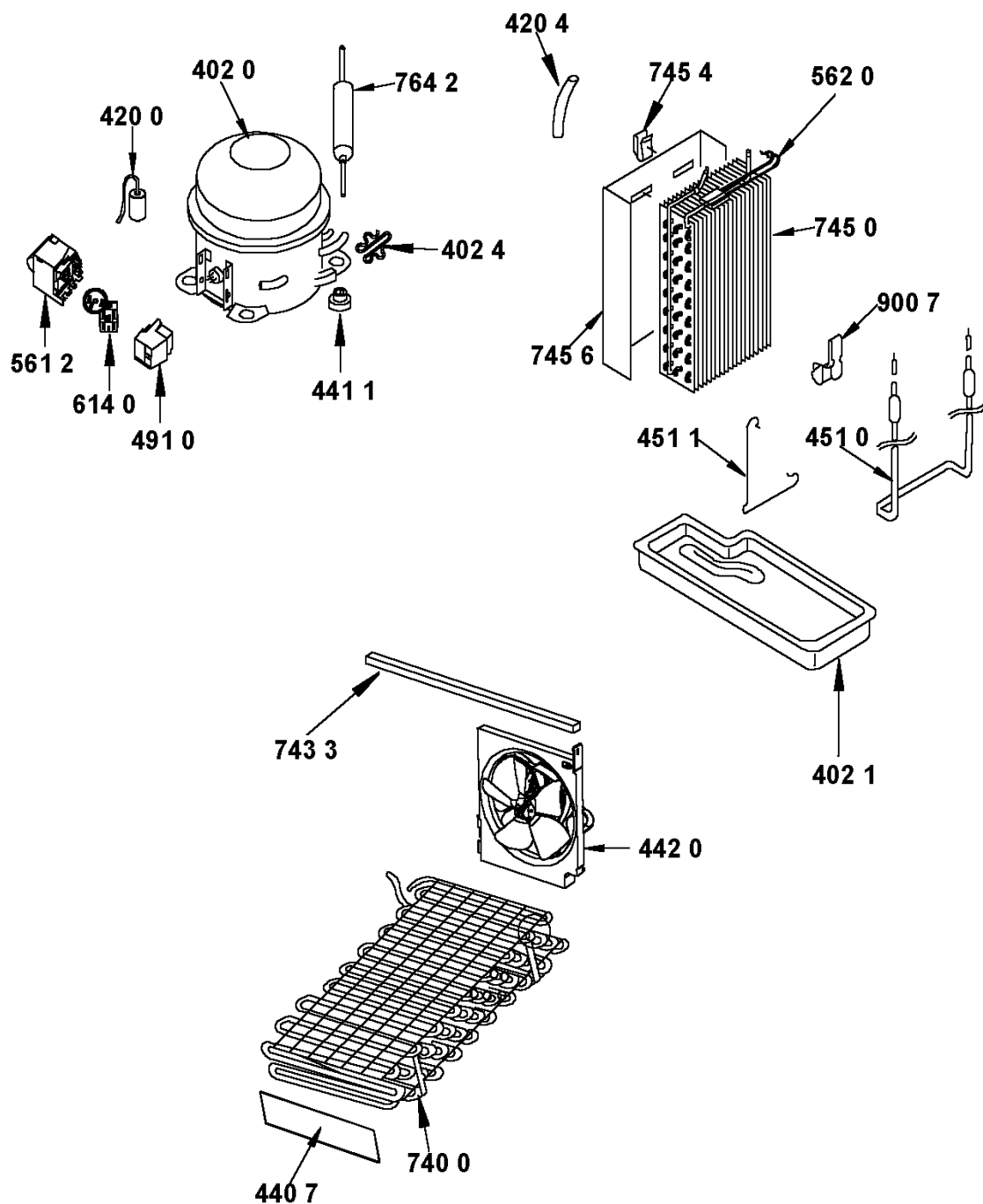

0000 001 70429

VUE ECLATEE

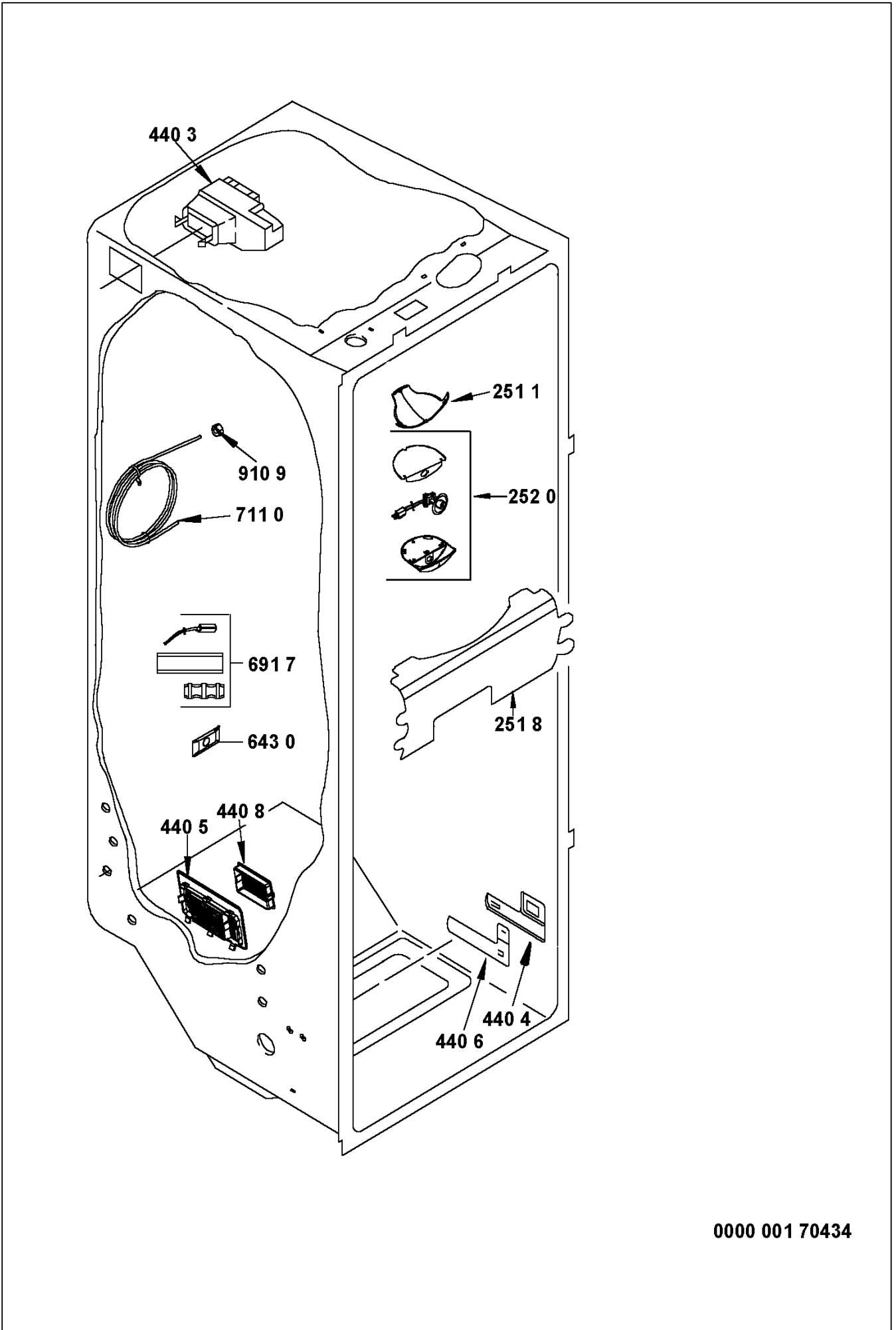

SCHEMAS DE PRINCIPE ET DE CABLAGE

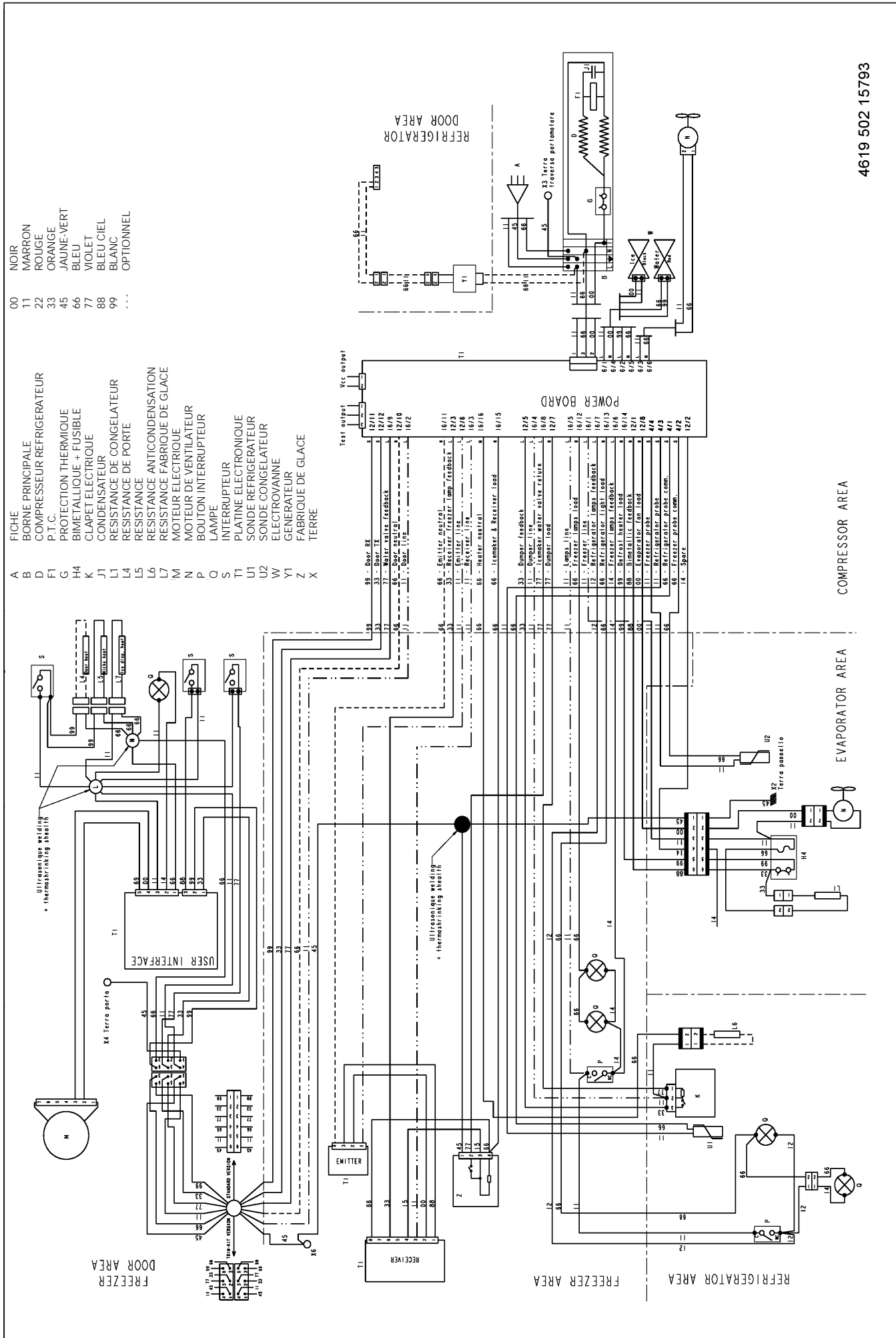

4619 502 15793

SCHEMAS DE PRINCIPE ET DE CABLAGE

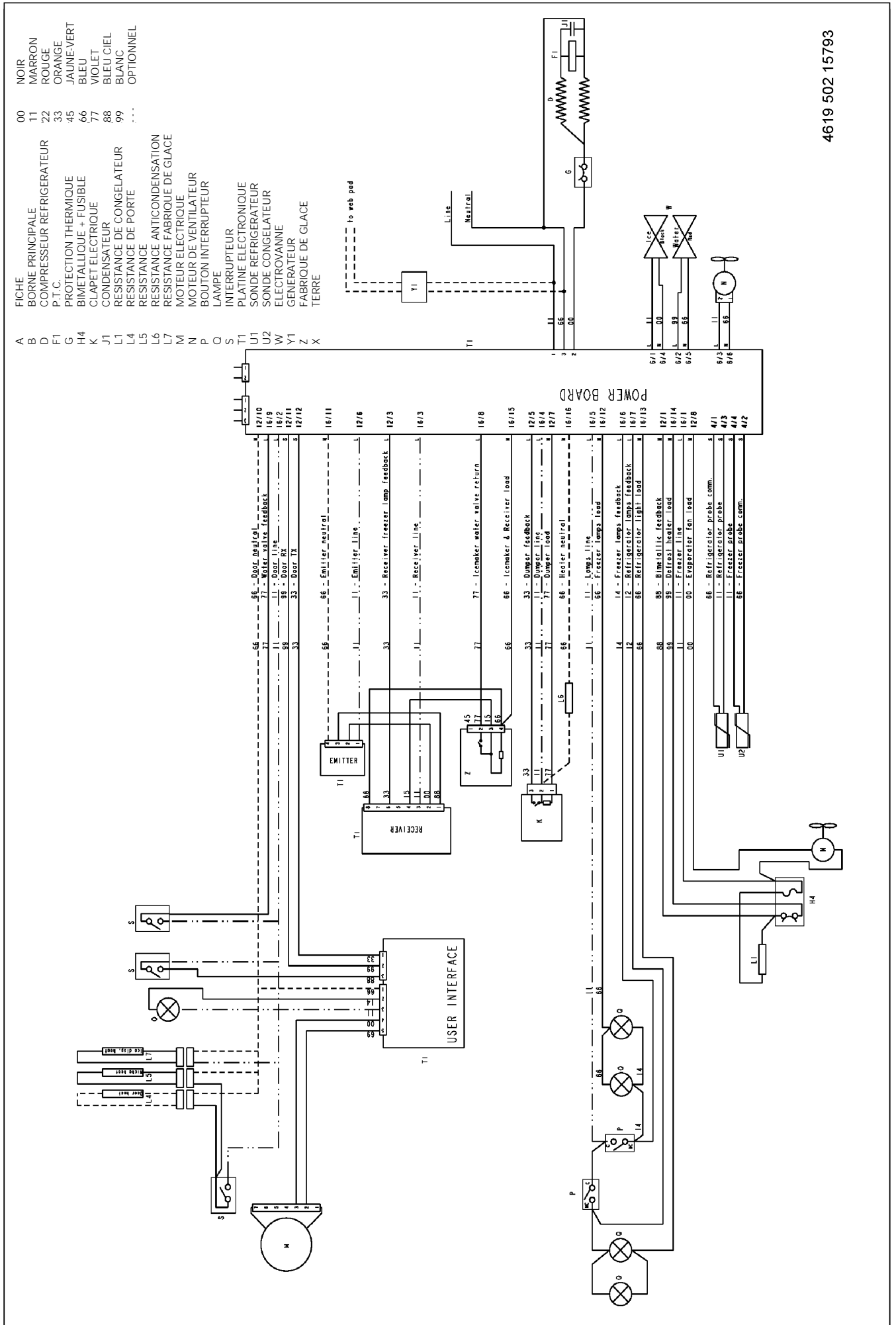

4619 502 15793