

Service Manual

VACCUM CLEANER

MODEL : RC-4008BA

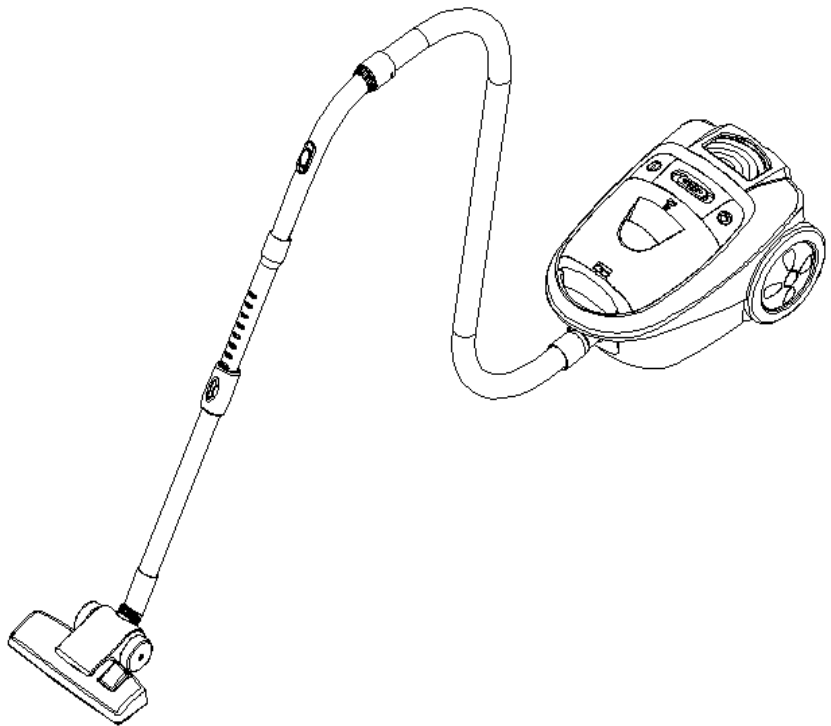

✓ Caution

: In this Manual, some parts can be changed for improving, their performance without notice in the parts list. So, if you need the latest parts information, please refer to PPL(Parts Price List) in Service Information Center (<http://svc.dwe.co.kr>).

DAEWOO ELECTRONICS CORP.

DAEWOO

CONTENTS

	Page
1. SPECIFICATIONS -----	2
2. EXTERNAL VIEWS -----	3
3. DIAGRAM -----	4
3-1. WIRING DIAGRAM -----	4
3-2. CIRCUIT DIAGRAM -----	4
4. TROUBLE SHOOTING GUIDE -----	5
5. DISASSEMBLING AND TREATMENT -----	7
5-1. CLEANER ASSEMBLY -----	7
5-2. BODY ASSEMBLY -----	8
5-3. MOTOR ASSEMBLY -----	9
5-4. CORDREEL ASSEMBLY -----	10
5-5. PCB ASSEMBLY -----	12
5-6. HOSE ASSEMBLY -----	13
5-7. BRUSH ASSEMBLY -----	14
5-8. DUST BOX ASSEMBLY -----	15
6. EXPLODED VIEW AND PARTS LIST -----	16
6-1. CLEANER ASSEMBLY -----	16
6-2. BODY ASSEMBLY -----	18
6-3. COVER BODY ASSEMBLY -----	20
6-4. COVER DUST ASSEMBLY -----	21
6-5. DUST BOX ASSEMBLY -----	22
6-6. MOTOR ASSEMBLY -----	23
6-7. CORDREEL ASSEMBLY -----	24
6-8. CASE MOTOR UPPER ASSEMBLY -----	26
6-9. HOSE ASSEMBLY -----	28
6-10. PIPE ASSEMBLY -----	30
6-11. BRUSH ASSEMBLY -----	31

1. SPECIFICATIONS

MODEL	RC-4008BA
Rated Voltage/Frequency	AC 230V, 50/60Hz
Input Watt	1800W
Suction Power	450W
Noise Level	75dB(A)
Weight (Body)	4.7Kg
Electrical Components	Thermostat (T80:80 °C OFF)
Dimension (WXHxD)	437 X 229 X 294 mm
Cord Length	5.0m
Filter	General (HEPA optional)
Pipe	Telescopic
Nozzle	Pedal
	Crevice Nozzle

2. EXTERNAL VIEWS

	PART NAME	RC-4008B
A	FILTER	General (or HEPA)
B	BODY VARIABLE	O
C	HOSE HANDLE	FLAT Type
D	PIPE	TELESCOPIC
E	NOZZLE	PEDAL
F	CORD	O

■ FILTER : GENERAL(3621909500, SPONGE 20T), HEPA(3621908510)

■ PIPE : TELESCOPIC(3624411470)

■ NOZZLE : PEDAL(3629306610)

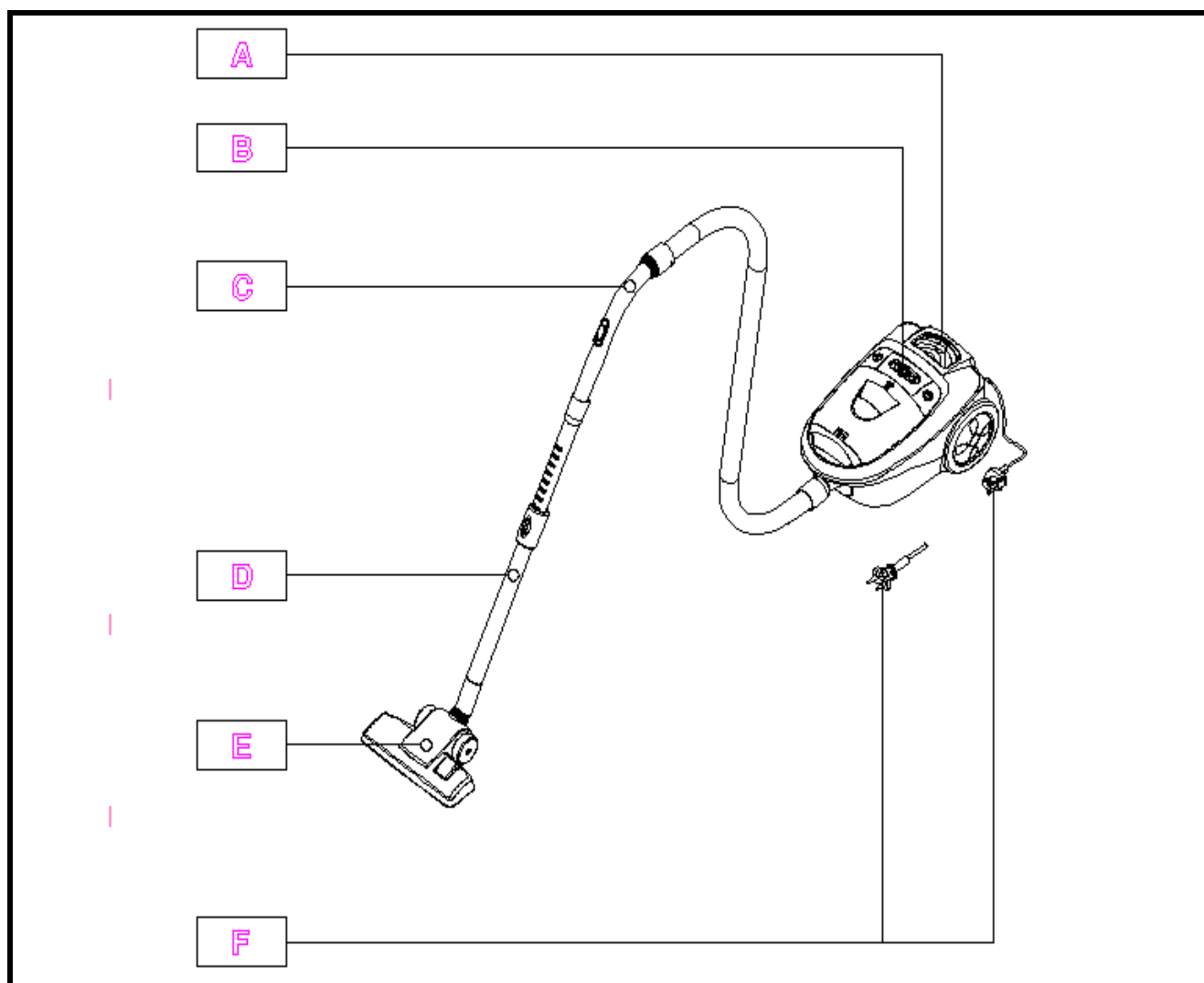

3. DIAGRAM

3-1. WIRING DIAGRAM

1) MODEL RC-4008B

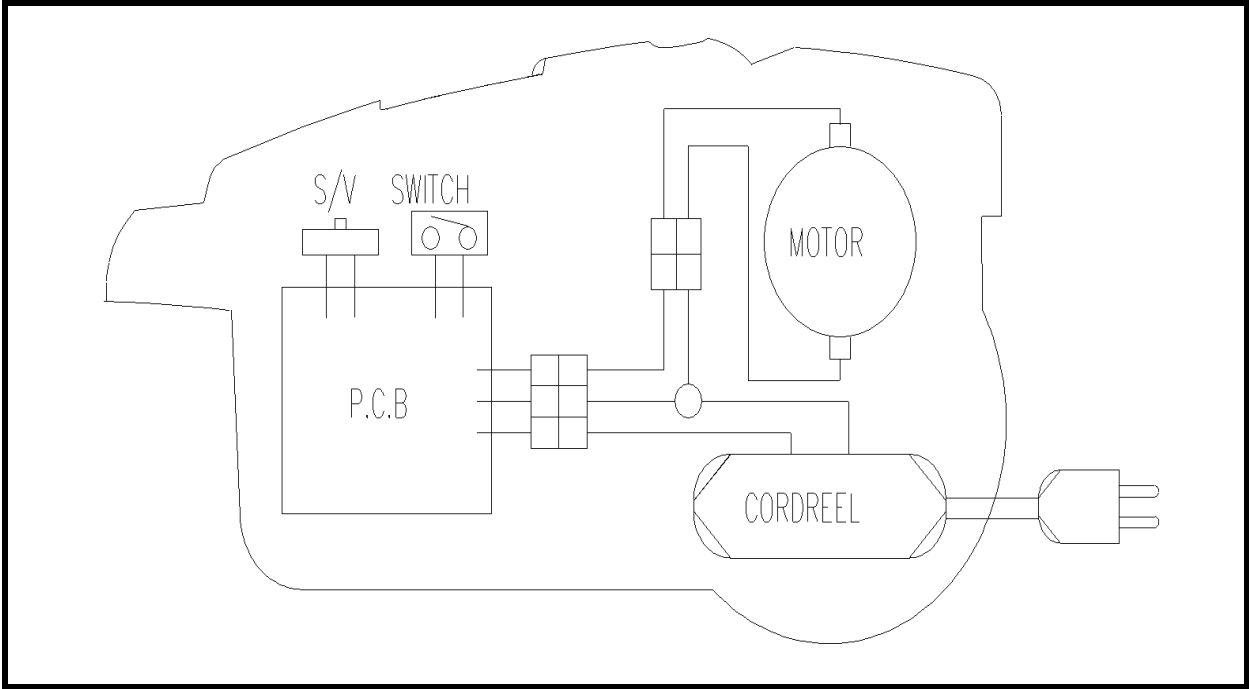

3-2. CIRCUIT DIAGRAM

1) MODEL RC-4008B

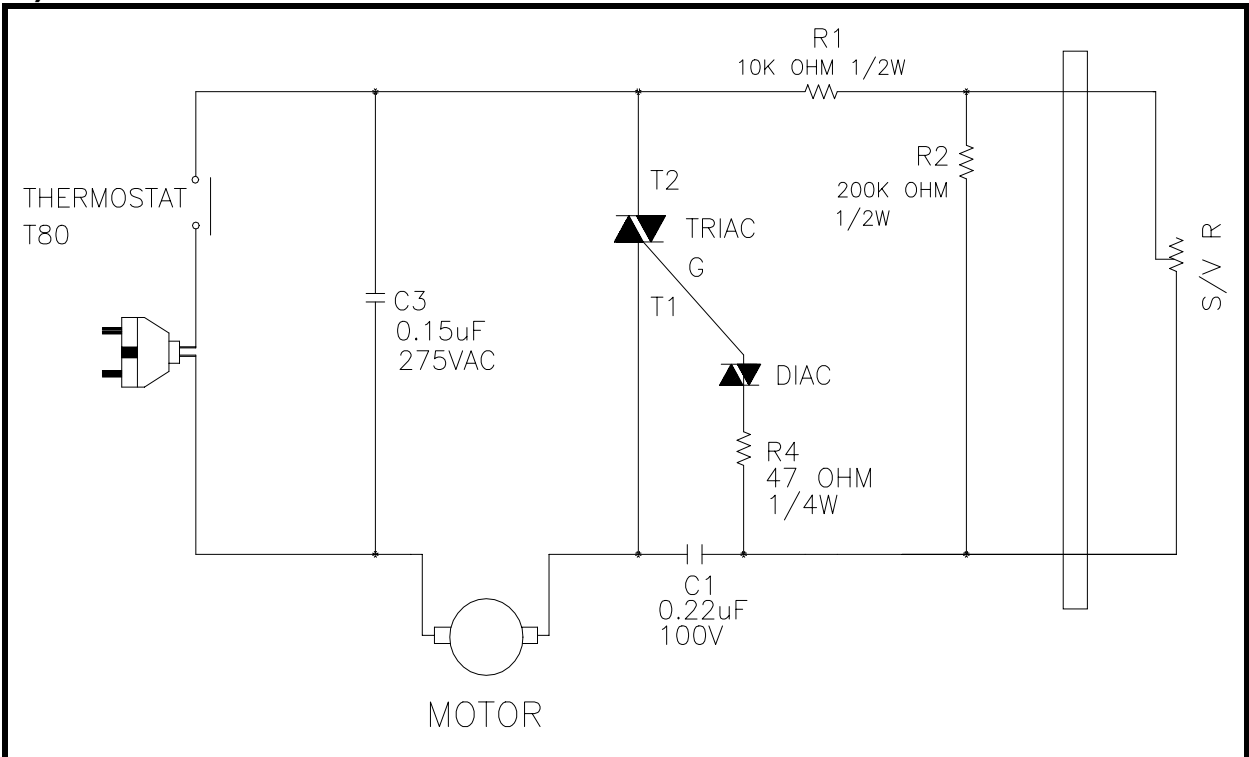

4. TROUBLE SHOOTING GUIDE

TROUBLE	CAUSE	COUNTERMEASURE
<p>SUCTION POWER IS WEAK</p>	<p>FILTER BAG(PAPER)/DUST BOX IS FULL WITH DUST</p>	<p>CHANGE IT WITH NEW ONE (See 5-1,8) REMOVE THE DUST IN DUST BOX</p>
	<p>FILTER PRE IS CLOGGY WITH DUST</p>	<p>REMOVE THE DUST (See 5-2)</p>
	<p>CLOGGING OR TEAR IN HOSE</p>	<p>REMOVE OBSTACLE OR REPLACE THE HOSE (See 5-6)</p>
	<p>DEFECTIVE MOTOR</p>	<p>REPLACE THE MOTOR (See 5-3)</p>
	<p>THE OPENING IN BRUSH IS CLOGGY WITH DUST</p>	<p>REMOVE THE DUST (See 5-7)</p>
<p>VACUUM CLEANER DOES NOT WORK</p>	<p>BREAKING IN POWER CORD (AT BLADE TIP OR ROOT OF PLUG)</p>	<p>REPLACE THE POWER CORD (See5-4)</p>
	<p>BREAKING OF CONNECTIONS IN HOSE ASSEMBLY</p>	
	<p>DEFECTIVE SLIDE VOLUME LOCATED IN CASE MOTOR UPPER</p>	<p>REPLACE IT (See 5-3)</p>
	<p>DEFECTIVE PCB ASSEMBLY</p>	<p>REPLACE IT (See 5-5)</p>
	<p>BREAKING OF CONNECTIONS OR POOR CONTACTS IN CORD REEL ASSEMBLY</p>	<p>REPAIR (See 5-4)</p>
	<p>DEFECTIVE MOTOR</p>	<p>REPLACE IT (See 5-3)</p>
	<p>BREAKING OF CONNECTIONS IN BODY ASSEMBLY</p>	<p>REPAIR (See 5-2)</p>
	<p>BREAKING IN A FUSE</p>	
<p>MOTOR DOES NOT STOP EVEN IF SWITCH</p>	<p>DEFECTIVE PCB ASSEMBLY</p>	<p>REPLACE IT (See 5-5)</p>

TROUBLE	CAUSE	COUNTERMEASURE
POWER CORD IS NOT WOUND UP	BROKEN REEL SPRING OF CORD REEL	REPLACE IT (See 5-4)
	POWER CORD BROKE AWAY FROM THE BOBBIN	REPAIR (See 5-4)
 CAUTION	BE CAREFUL WHEN BREAKING UP THE CORD REEL, THE REELSPRING MAY SPRING OUT OF THE SPRING COVER.	
	POWER CORD DOES NOT STOP AT AN ARBITRARY POSITION	ABRASION OF THE ROLLER BRAKE OF CORD REEL
LEVER SPRING BROKE AWAY FROM THE CORD REEL BRACKET		REPAIR (See 5-4)

5. DISASSEMBLING AND TREATMENT

5-1. CLEANER ASSEMBLY

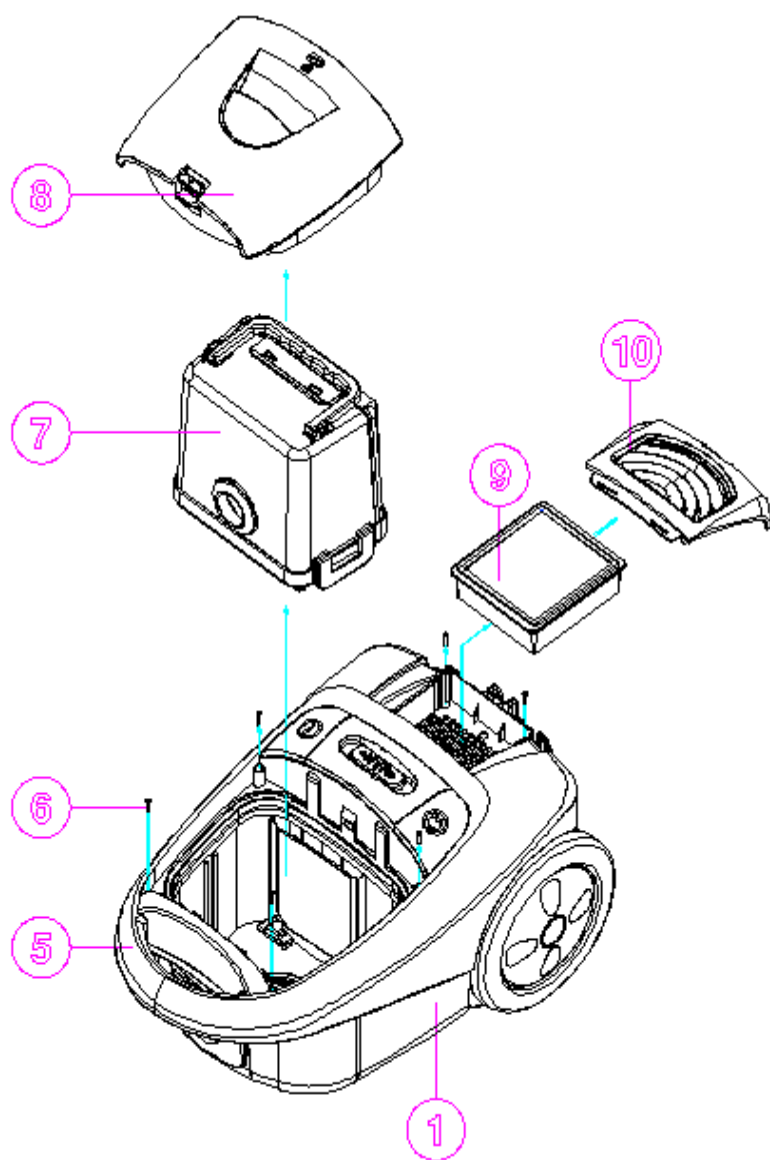

- 1) LIFT THE DUST COVER(8), GRILLE(10), FILTER(9) AND UNSCREW THE 6 SCREWS(6) AND THEN LIFT THE COVER ASSEMBLY(5) UP FROM THE BODY ASSEMBLY(1).
- 2) CHECK THE DUST BOX.
- 3) CHECK THE FILTER (9).

5-2. BODY ASSEMBLY

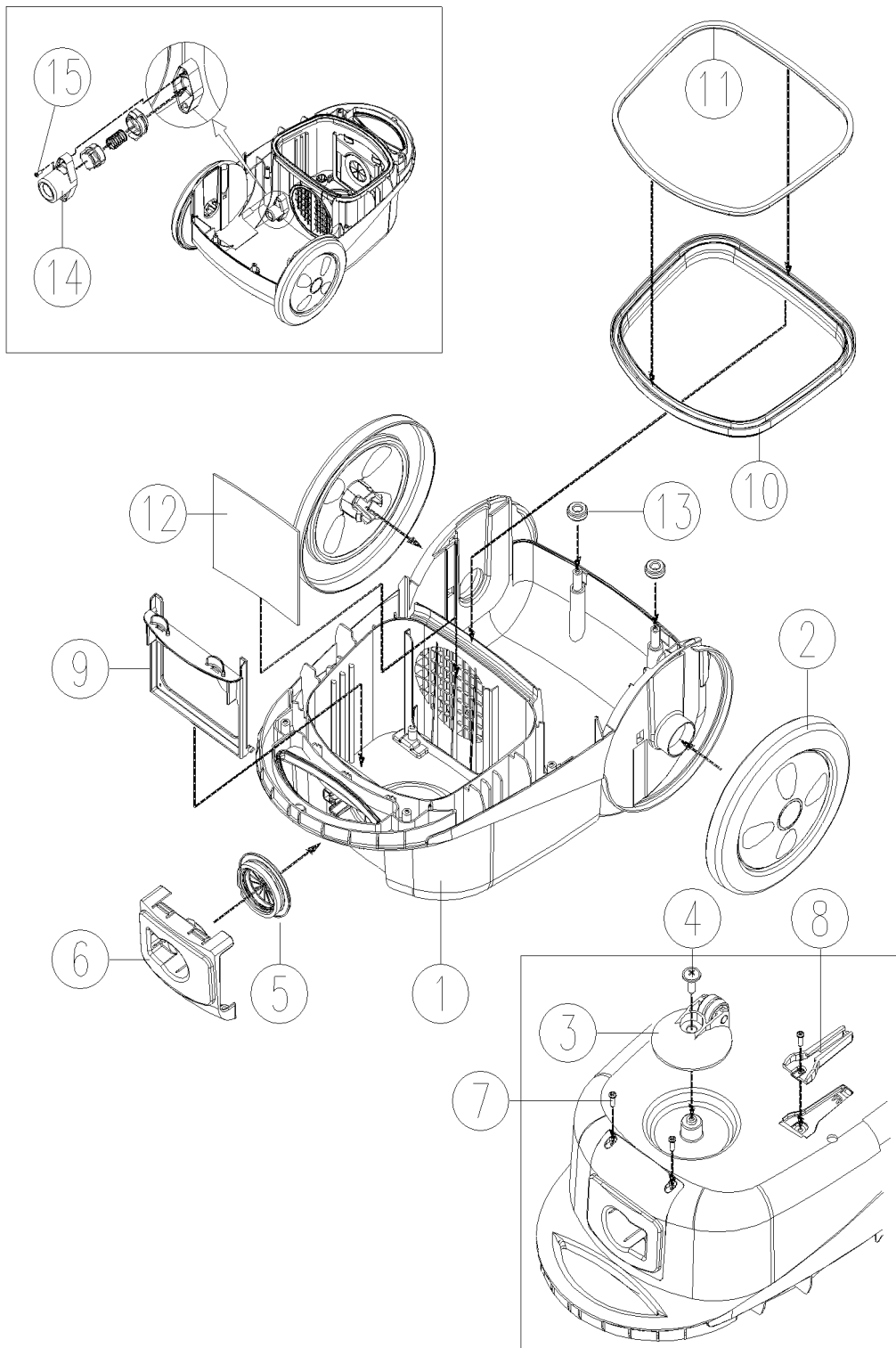

- 1) CHECK THE SAFETY VALVE ASSEMBLY (14).
- 2) CHECK THE GASKET (11).
- 3) CHECK THE HOLDER FILTER (9).
- 4) CHECK THE FILTER PRE (12).

5-3. MOTOR ASSEMBLY

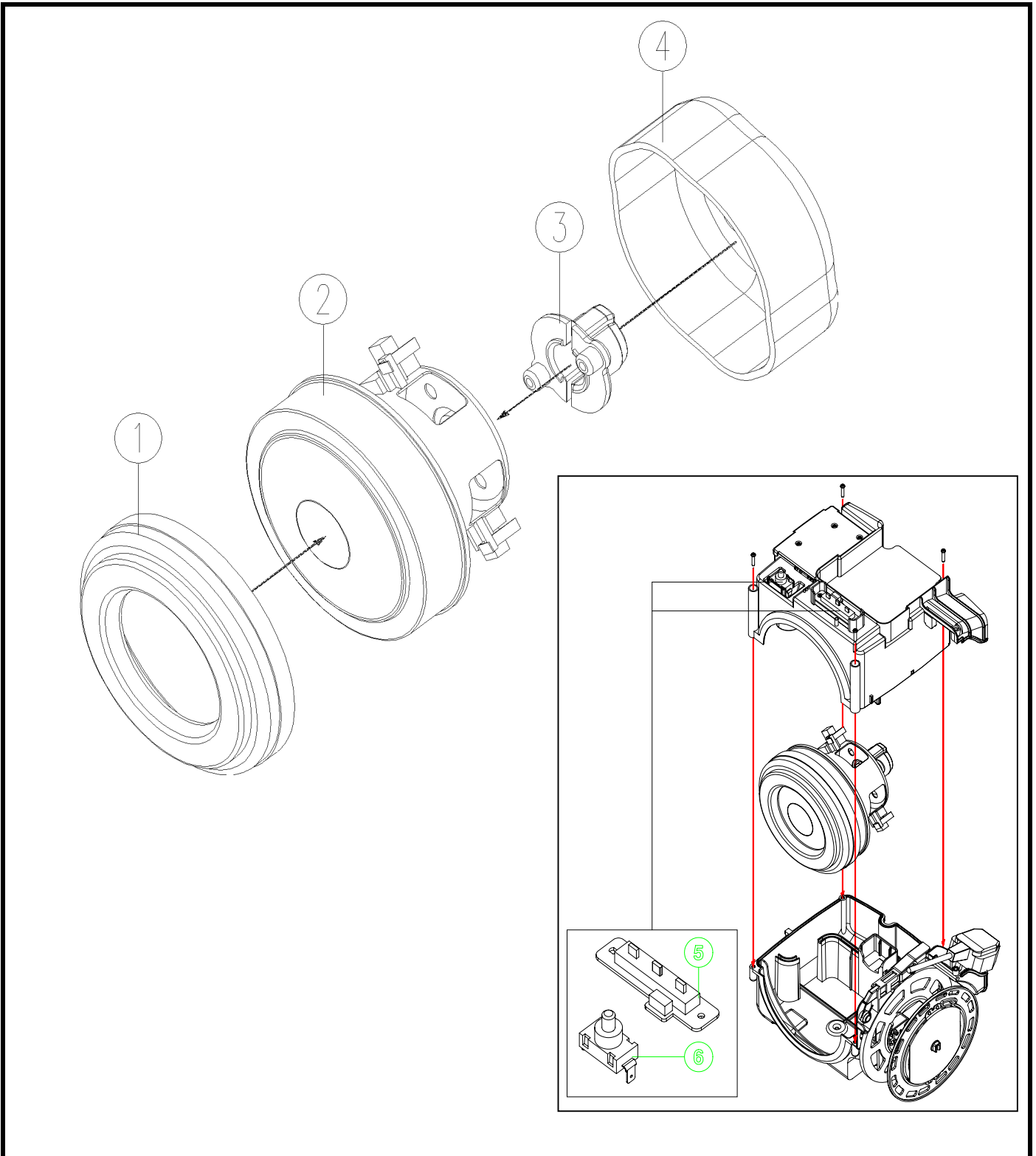

- 1) TAKE THE MOTOR ASSEMBLY OUT OF THE CASE MOTOR ASSEMBLY.
- 2) CHECK THE MOTOR(2) (WHETHER THE MOTOR IS BURNT OUT OR NOT).
- 3) CHECK THE CONNECTION BETWEEN MOTOR TERMINAL AND THE LEADS.
- 4) CHECK THE SLIDE VOLUME(5) AND SWITCH(6).

5-4. CORDREEL ASSEMBLY

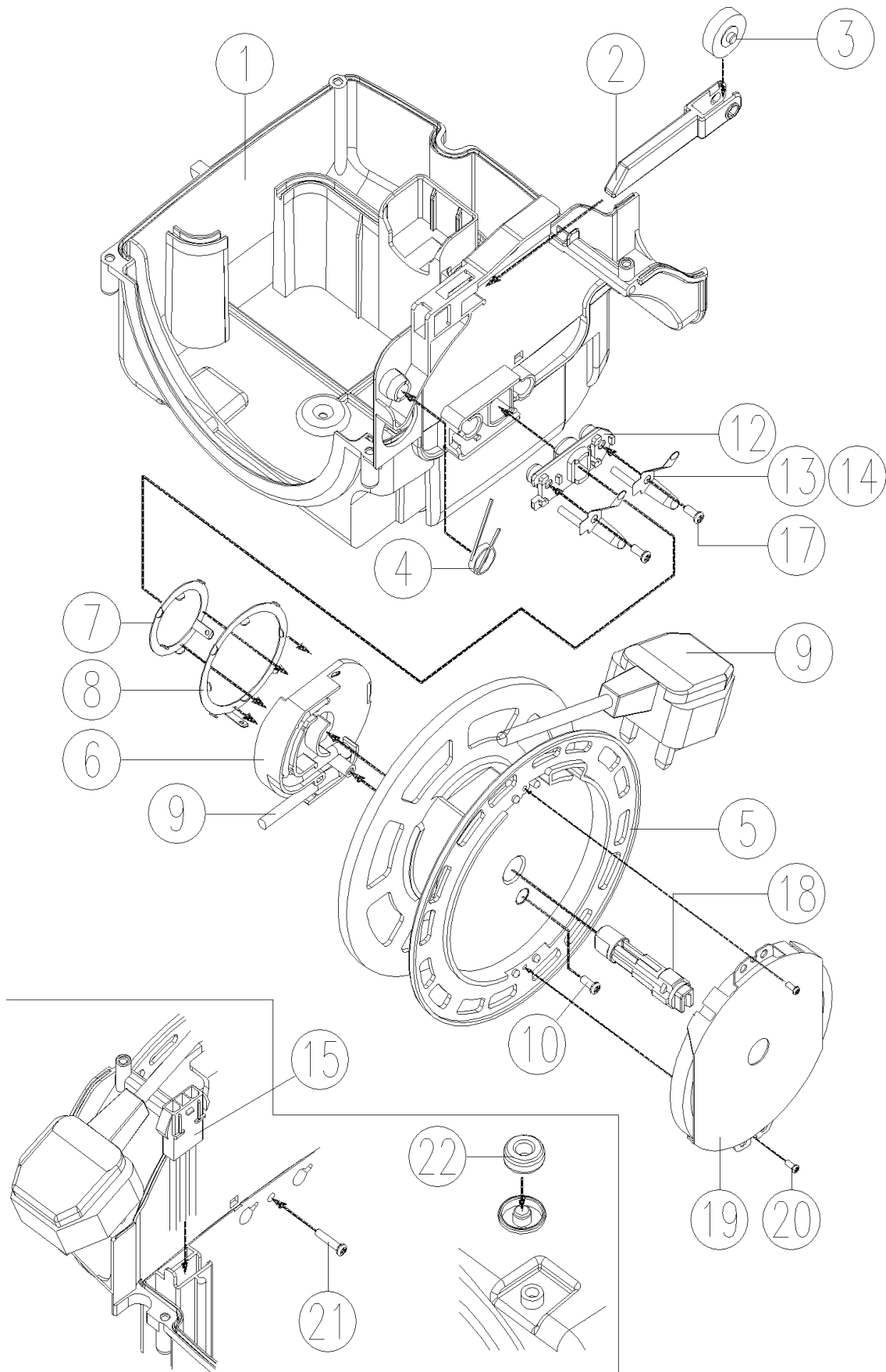

-
- 1) TAKE THE CORD REEL ASSEMBLY OUT OF THE BODY ASSEMBLY.
 - 2) UNSCREW THE SCREW(21).
 - 3) SEPARATE THE BOBBIN(5) FROM THE CASE MOTOR BOTTOM(1) AND CHECK THE CONTACTS BETWEEN THE Y TYPE TERMINALS(13,14) AND THE RING TYPE TERMINALS(7,8).
 - 4) CHECK THE LEVER SPRING(4).
 - 5) IF THE ROLLER BRAKE(3) IS WORN OUT AND SEPARATE THE LEVER(2) FROM THE CASE MOTOR BOTTOM(1), THEN REPLACE THE ROLLER BRAKE(3). AT THIS TIME, THE BOBBIN(5) IS ROTATED COUNTERCLOCKWISE DUE TO THE PRESERVED WINDING.
 - 6) IF THE REEL SPRING(19) IS BROKEN, UNSCREW THE 2 SCREWS(20) AND REPLACE IT.



**WHEN DISASSEMBLING, THE REEL SPRING MAY
SPRING OUT OF THE COVER.**

- 7) UNSCREW THE SCREW (10) AND SEPARATE THE HOLDER TERMINAL(6) FROM THE BOBBIN(5).
- 8) CHECK THE CONNECTIONS BETWEEN THE POWER CORD(9) AND THE RING TERMINALS(7,8).
- 9) WHEN ASSEMBLING, MAKE THE RESERVED WINDING 5 REVOLUTIONS OF THE BOBBIN CLOCKWISE.

5-5. PCB ASSEMBLY

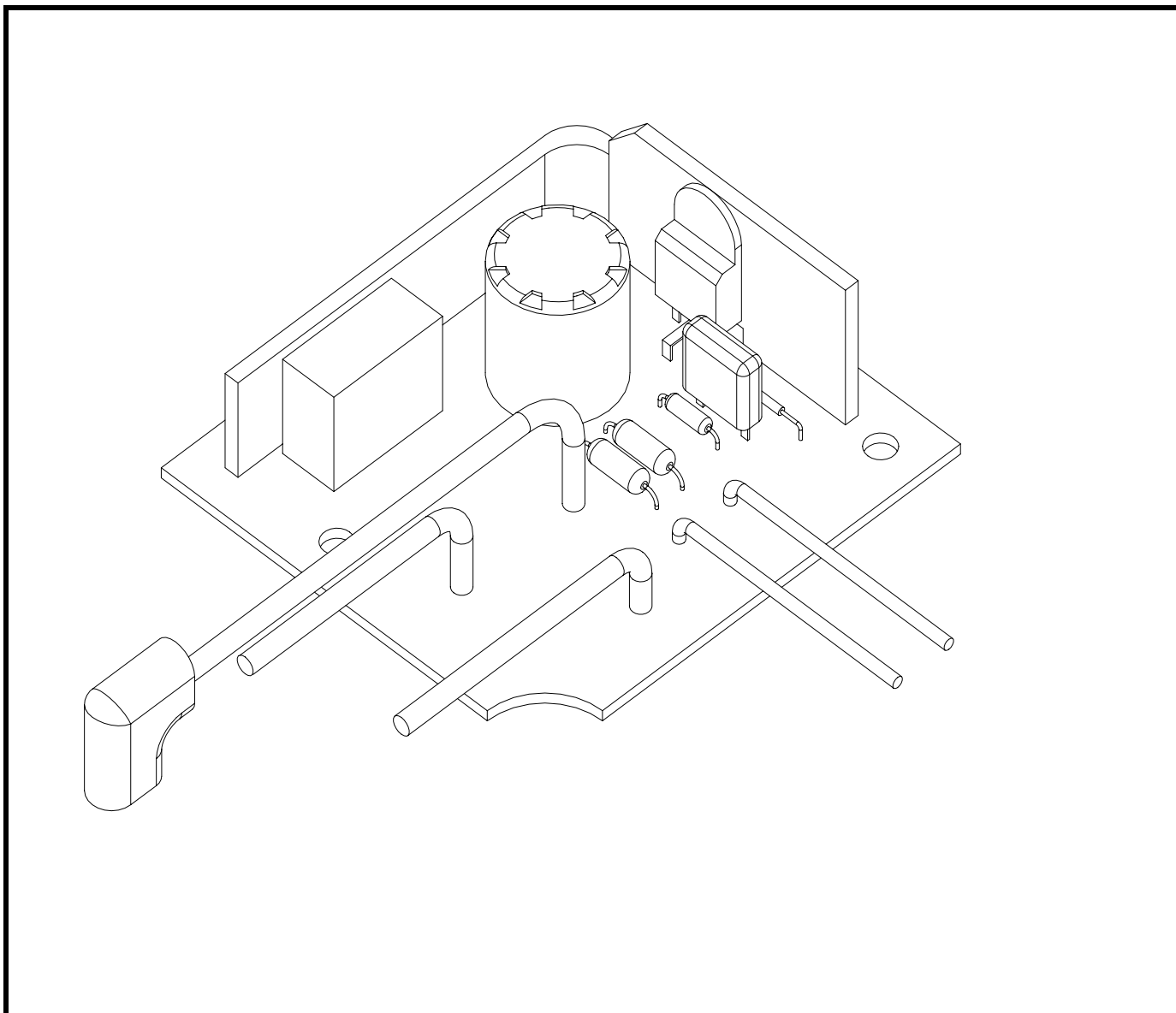

- 1) CHECK THE CONNECTIONS BETWEEN THE WIRES AND PCB BOARD.
- 2) CHECK THE THERMOSTAT

5-6. HOSE ASSEMBLY

1) MODEL RC-4005B'S, RC-4006B'S(3623210600)

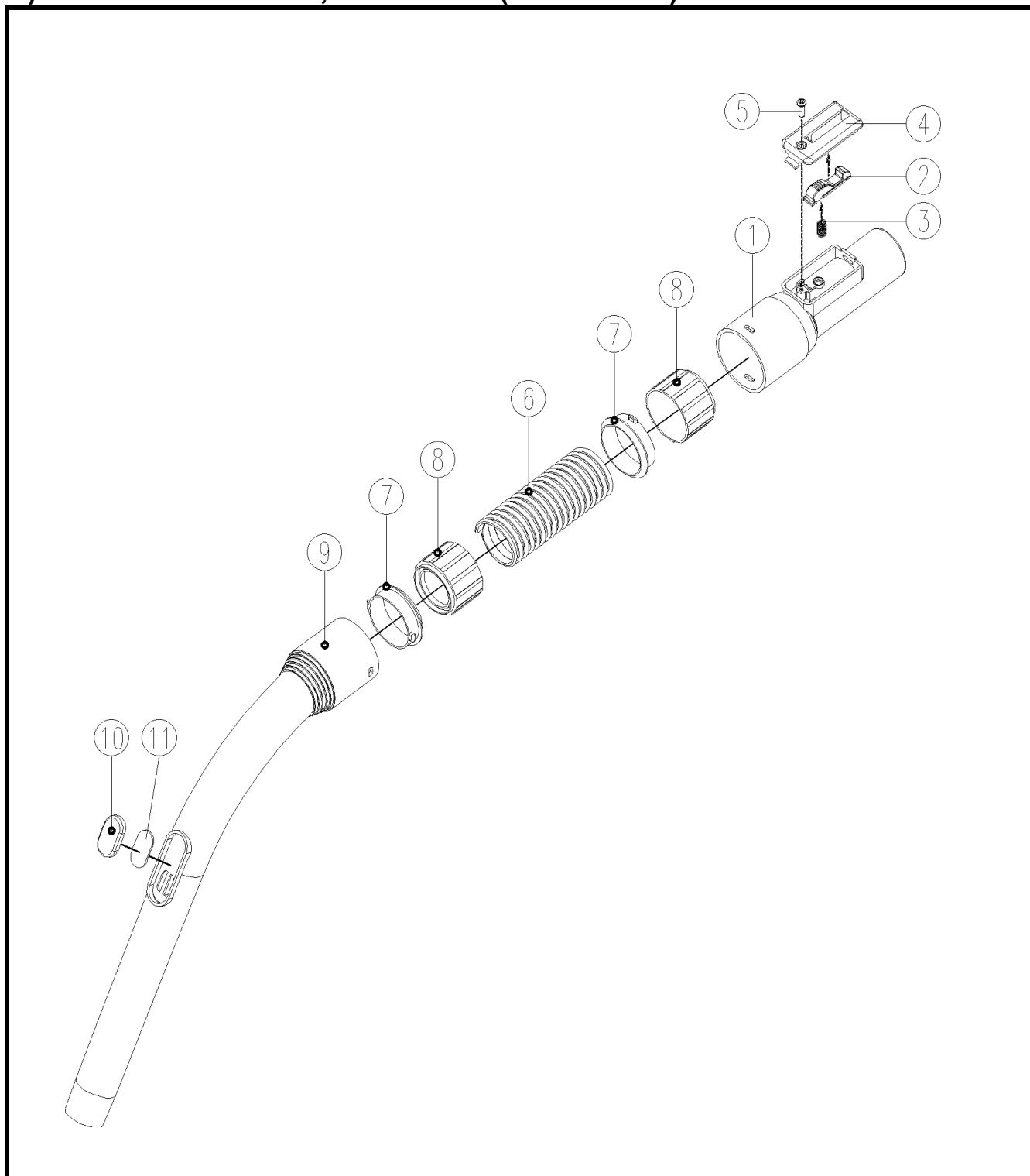

- 1) UNSCREW THE 1 SCREWS(5) AND CHECK WHETHER THE CLAMP(2) IS BROKEN OR NOT.
- 2) CHECK THE PACKING(10, 11) AND HOSE(6).

5-7. BRUSH ASSEMBLY

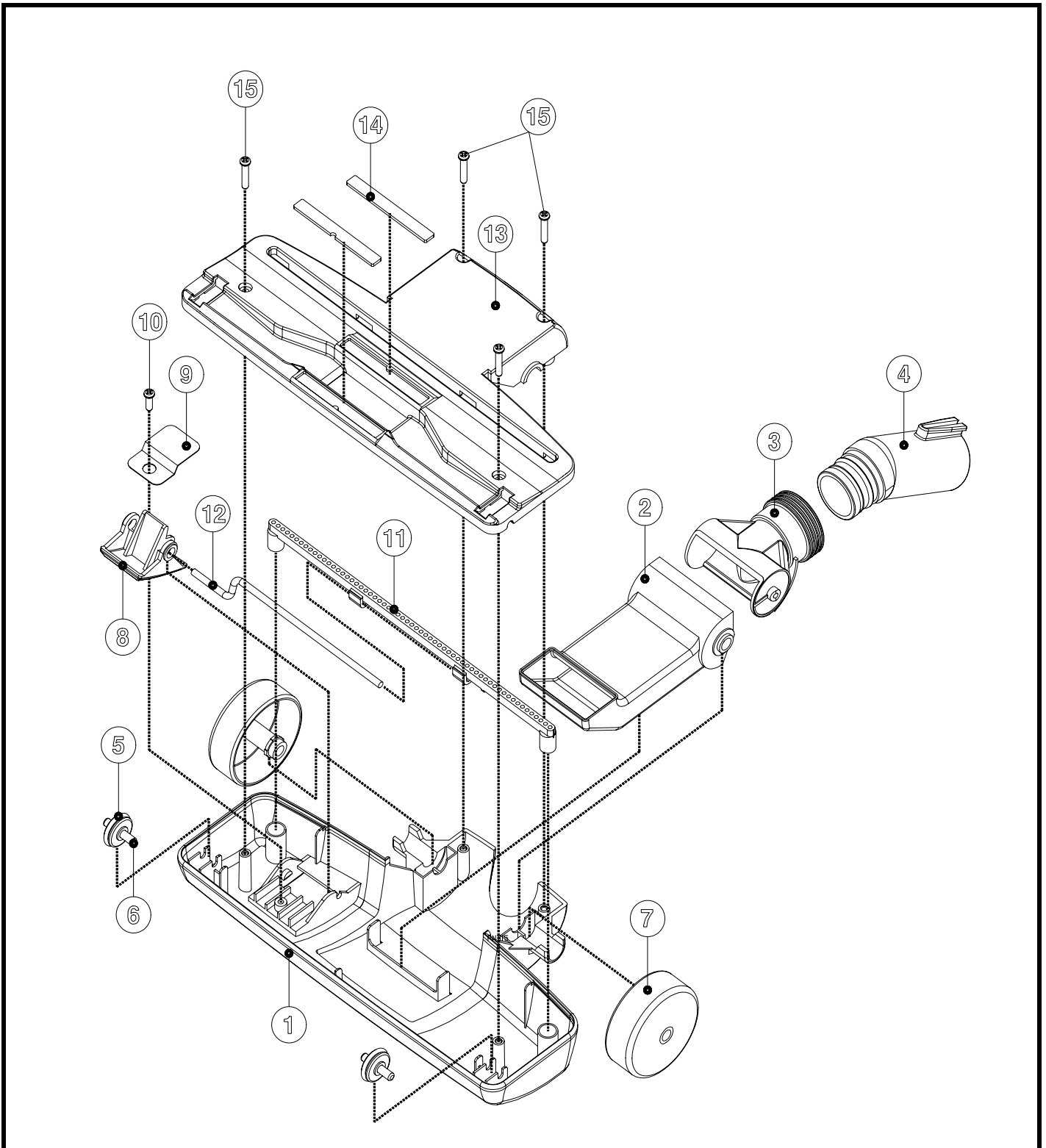

- 1) TO SEPARATE THE PIPE BRUSH(4) FROM THE COVER BRUSH(1), UNSCREW THE 4 SCREWS(15).
- 2) CHECK THE OPENING OF THE NECK BRUSH(8) AND THE PIPE BRUSH(5).

5-8. DUST BOX ASSEMBLY

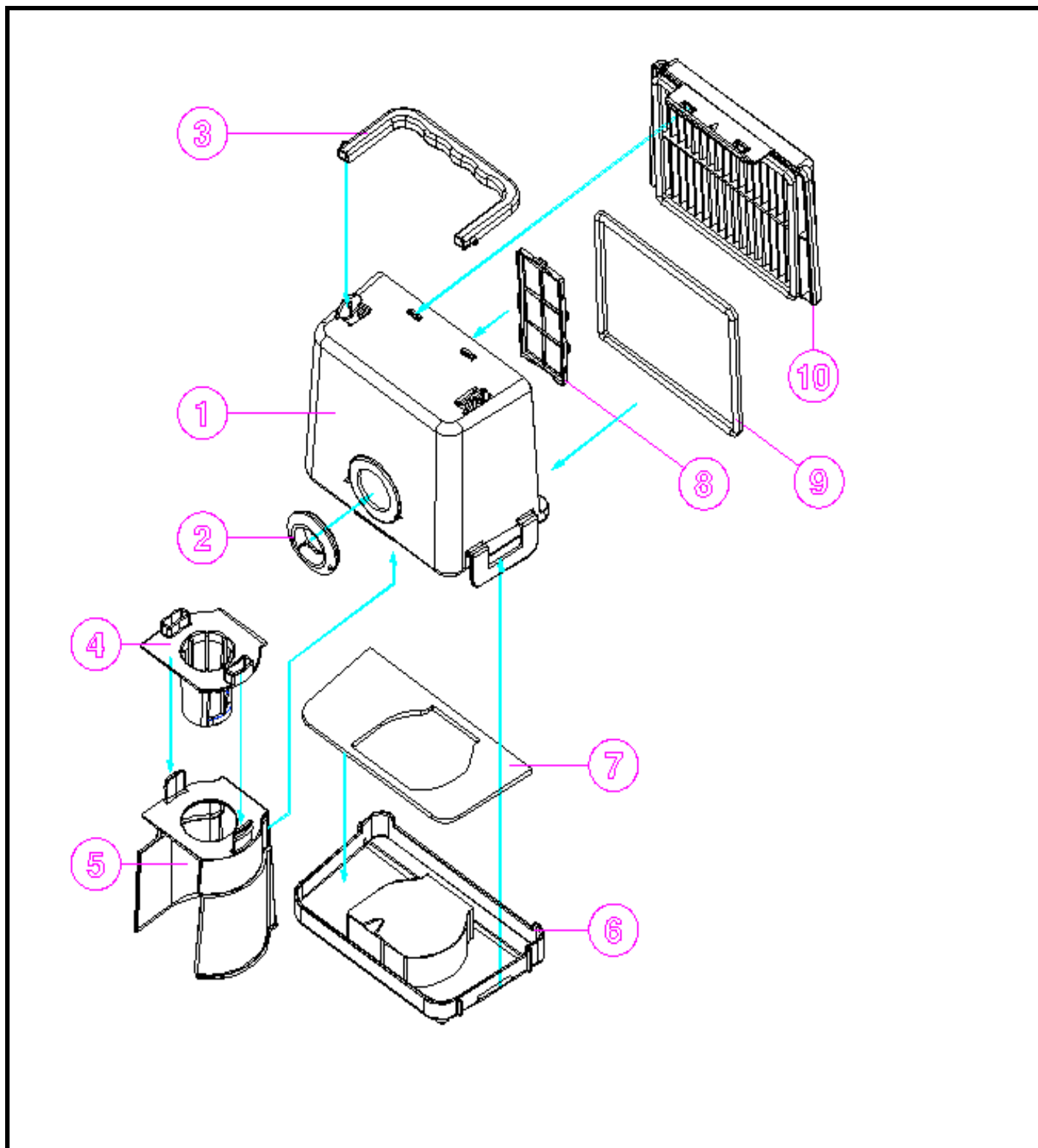

- 1) CHECK THE MESH FILTER(4, 8).
- 2) CHECK THE WASHABLE FILTER(10).
- 3) CHECK THE PACKING(2,9).

6.EXPLODED VIEW AND PARTS LIST

6-1. CLEANER ASSEMBLY

1) MODEL RC-4008B

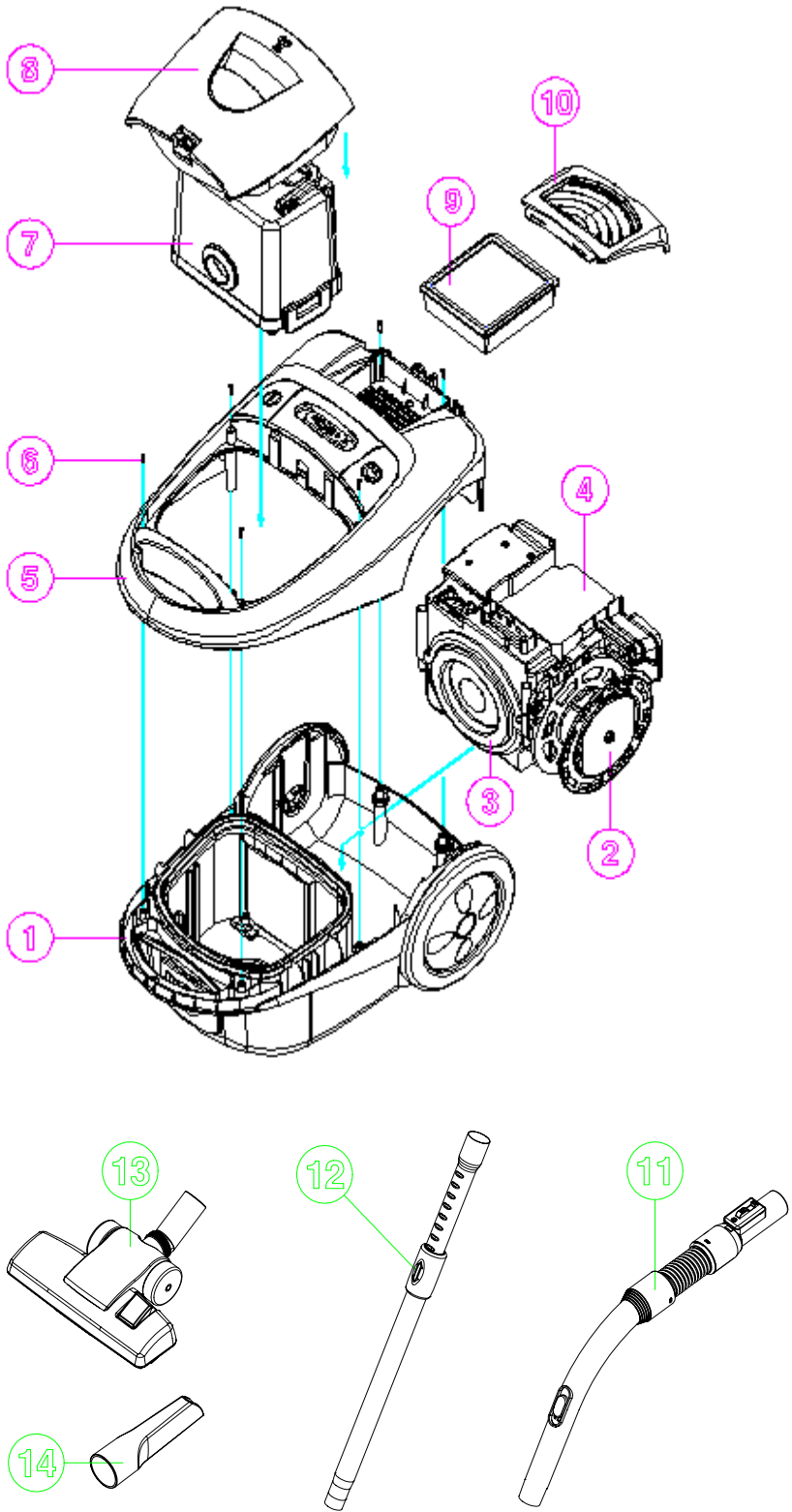

✓ **Caution** : In this Service Manual, some parts can be changed for improving, their performance without notice in the parts list. So, if you need the latest parts information, please refer to PPL(Parts Price List) in Service Information Center (<http://svc.dwe.co.kr>).

NO	PART NAME	PART CODE	SPECS.	Q'YT
1	BODY AS	3620412000	ASSY(RC-400,NON-CURRENT)	1
2	CORD REEL AS	3629508400	ASSY(UK)	1
3	MOTOR UNIVERSAL	3962511830	1600W 230V DMI VH122C6110	1
4	CASE MOTOR UPPER AS	3621107600	ASSY(RC-400)	1
5	COVER AS	3621438200	ASSY RC-400 SPRAY	1
6	SCREW TAPPING	7121402011	T2S PAN 4X20 MFZN	6
7	DUST BOX AS	3621910500	ASSY(RC-4008B)	1
8	COVER DUST AS	3621439500	ASSY(RC-4008B)	1
9	FILTER EXHAUST	3621908510	FRAME+HEPA	1
10	GRILL EXHAUST	3622401200	ABS	1
11	HOSE AS	3623210600	RC-400(WIRELESS, EVA)	1
12	PIPE AS	3624411470	SPC T=0.7	1
13	BRUSH AS	3629306610	PEDAL(NON-SILK)	1
14	NOZZLE CREVICE	3628100600	PP	1

6-2. BODY ASSEMBLY

1) MODEL RC-4008B (3620412000)

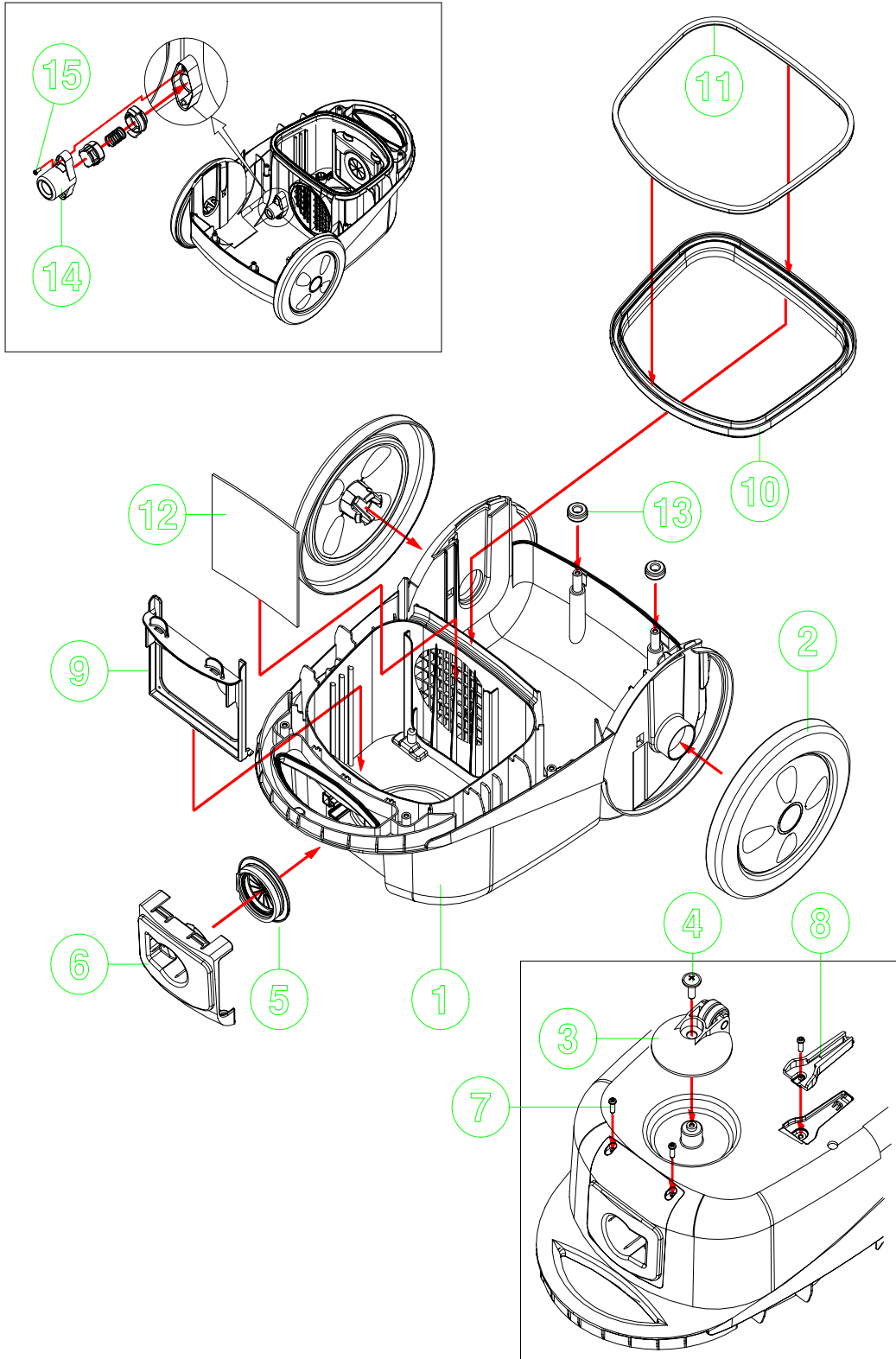

✓ **Caution** : In this Service Manual, some parts can be changed for improving, their performance without notice in the parts list. So, if you need the latest parts information, please refer to PPL(Parts Price List) in Service Information Center (<http://svc.dwe.co.kr>).

NO	PART NAME	PART CODE	SPECS.	Q'YT
1	BODY	3620411800	PP	1
2	ROLLER BACK	3624706900	PP	2
3	ROLLER AS	3624701300	BRACKET & ROLLER (P.P)	1
4	SCREW TAPPING	7128401212	T2S WAS 4X12 MFZN BK	1
5	PACKING SOCKET	3624008900	NR	1
6	SOCKET	3629802200	PP	1
7	SCREW TAPPING	7121401412	T2S PAN 4X14 MFZN BK	3
8	HOLDER BRUSH	3623005500	PP	1
9	HOLDER FILTER	3623008000	PP	1
10	FRAME GASKET	3622203600	ABS	1
11	GASKET	3622307400	NR FOAM(L=640MM)	1
12	FILTER PRE	3621907050	PE 3T BLACK	1
13	ABSORBER VIBRATION	3620112800	NR	2
14	SAFETY AS	3625400700	ASSY	1
15	SCREW TAPPING	7121301011	T2S PAN 3X10 MFZN	1

✓ **Caution** : In this Service Manual, some parts can be changed for improving, their performance without notice in the parts list. So, if you need the latest parts information, please refer to PPL(Parts Price List) in Service Information Center (<http://svc.dwe.co.kr>).

6-3. COVER ASSEMBLY

1) MODEL RC-4008B (3621438200)

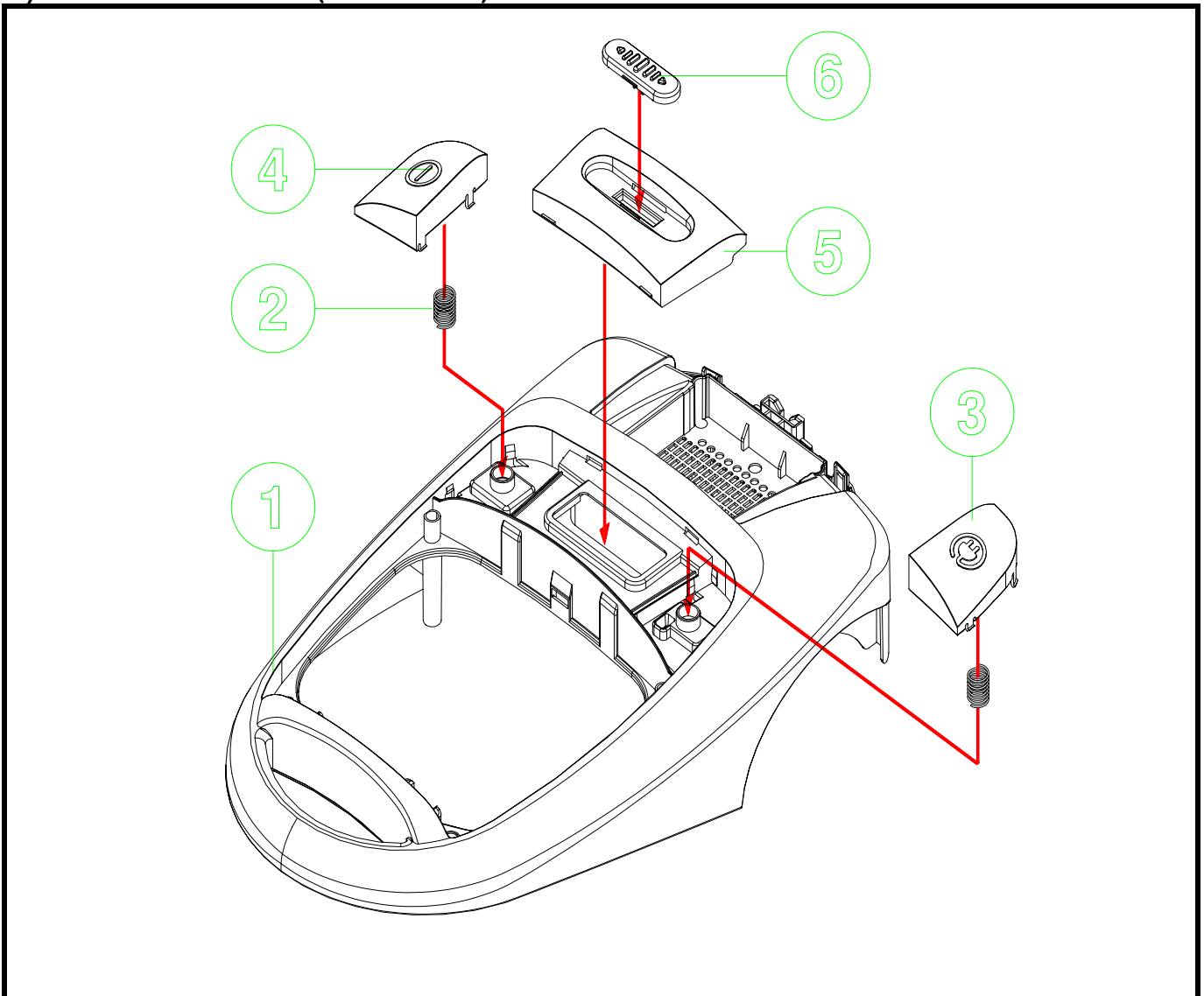

NO	PART NAME	PART CODE	SPECS.	Q'YT
1	COVER BODY	3621436800	ABS	1
2	SPRING BUTTON	3625108400	HSW3	2
3	BUTTON CR	3626607400	ABS	1
4	BUTTON SWITCH	3626607500	ABS	1
5	COVER MIDDLE	3621437000	ABS	1
6	KNOB	3623402000	PP	1

✓ **Caution** : In this Service Manual, some parts can be changed for improving, their performance without notice in the parts list. So, if you need the latest parts information, please refer to PPL(Parts Price List) in Service Information Center (<http://svc.dwe.co.kr>).

6-4. COVER DUST ASSEMBLY

1) MODEL RC-4008B (3621439500)

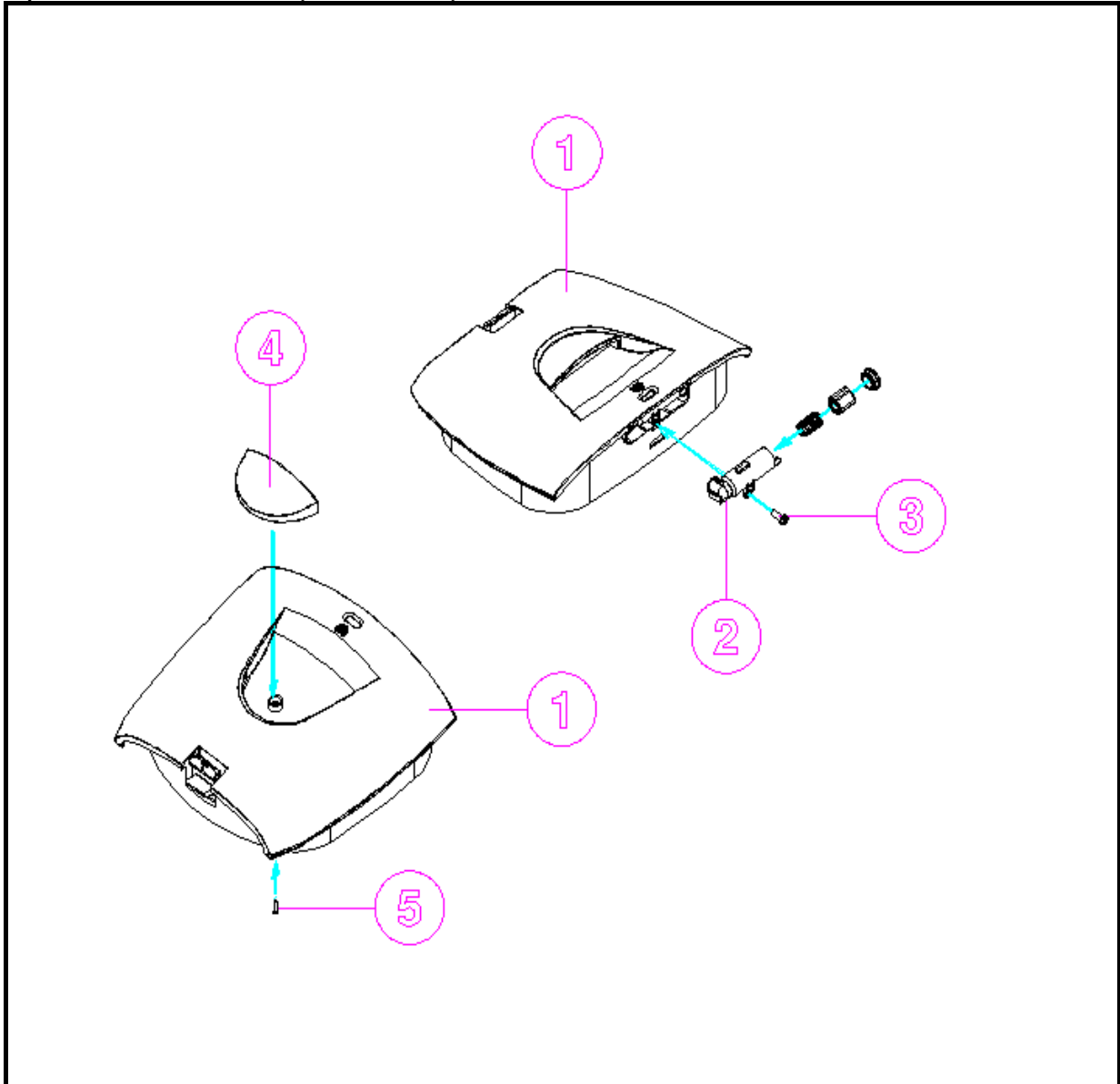

NO	PART NAME	PART CODE	SPECS.	Q'YT
1	COVER DUST	3621438700	ABS	1
2	DUST METER AS	3629704100	ASSY	1
3	SCREW TAPPING	7121301211	T2S PAN 3X12 MFZN	1
4	HANDLE DUST	3622604600	ABS	1
5	SCREW TAPPING	7121401411	T2S PAN 4X14 MFZN	1

✓ **Caution** : In this Service Manual, some parts can be changed for improving, their performance without notice in the parts list. So, if you need the latest parts information, please refer to PPL(Parts Price List) in Service Information Center (<http://svc.dwe.co.kr>).

6-5. DUST BOX ASSEMBLY

1) MODEL RC-4008B (3621910500)

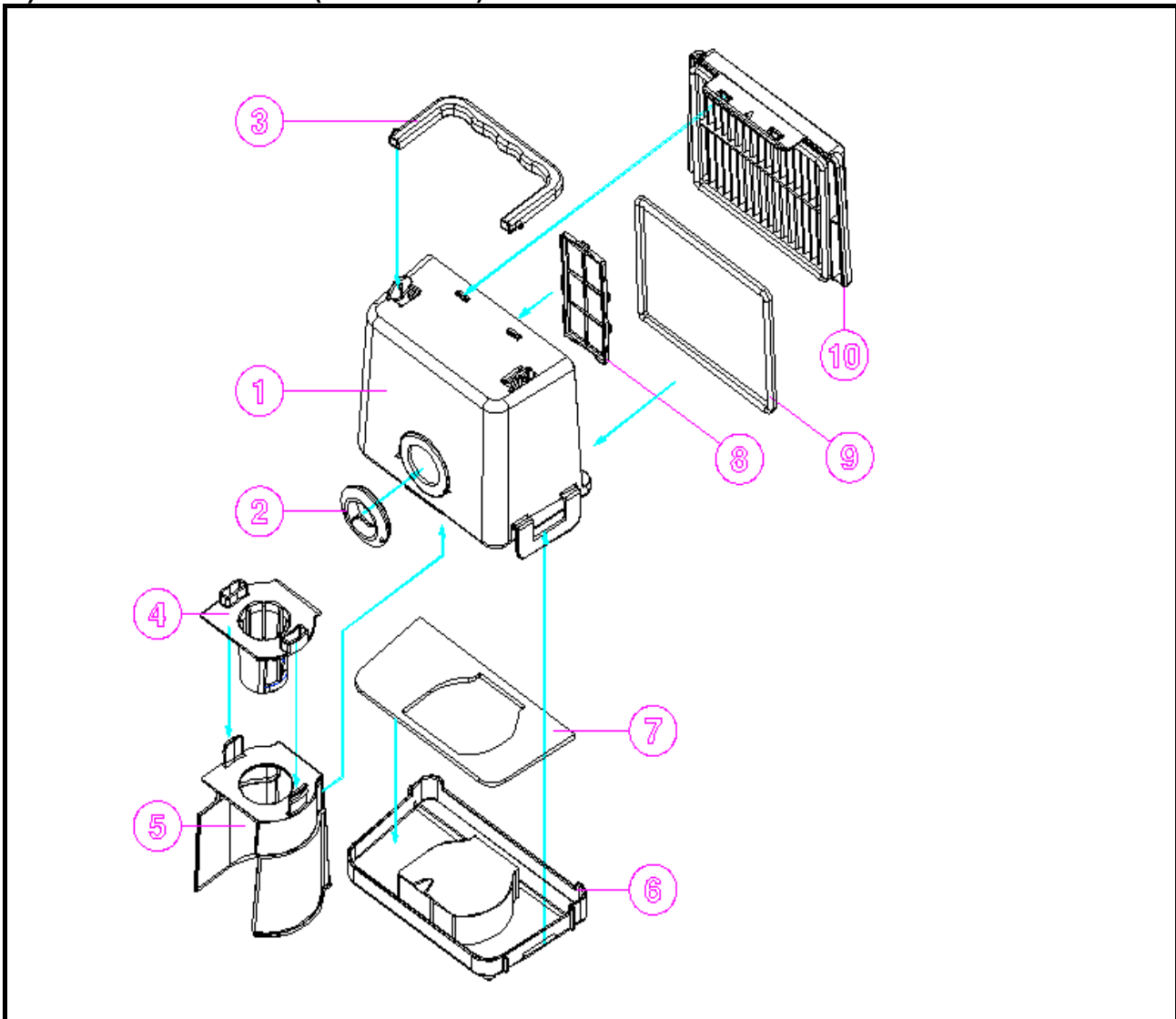

NO	PART NAME	PART CODE	SPECS.	Q'YT
1	BOX DUST	3620508700	ABS	1
2	PACKING DUST BOX	3624010000	NBR	1
3	HANDLE DUST BOX	3622604700	ABS	1
4	FRAME MESH FILTER	3622204100	ABS (INSERT, MESH FILTER)	1
5	GUIDE AIR FLOW	3622505800	ABS	1
6	COVER DUST BOX	3621438800	ABS (SILTER)	1
7	SEALER DUST BOX	3622307700	NR FOAM	1
8	FRAME MESH FILTER - R	3622204600	NYLON (INSERT, MESH FILTER)	1
9	GASKET FILTER	3622307600	NR FOAM	1
10	FRAME FILTER	3622307500	ABS (INSERT, WASHABLE FILTER)	1

✓ **Caution** : In this Service Manual, some parts can be changed for improving, their performance without notice in the parts list. So, if you need the latest parts information, please refer to PPL(Parts Price List) in Service Information Center (<http://svc.dwe.co.kr>).

6-6. MOTOR ASSEMBLY

1) MODEL RC-4008B

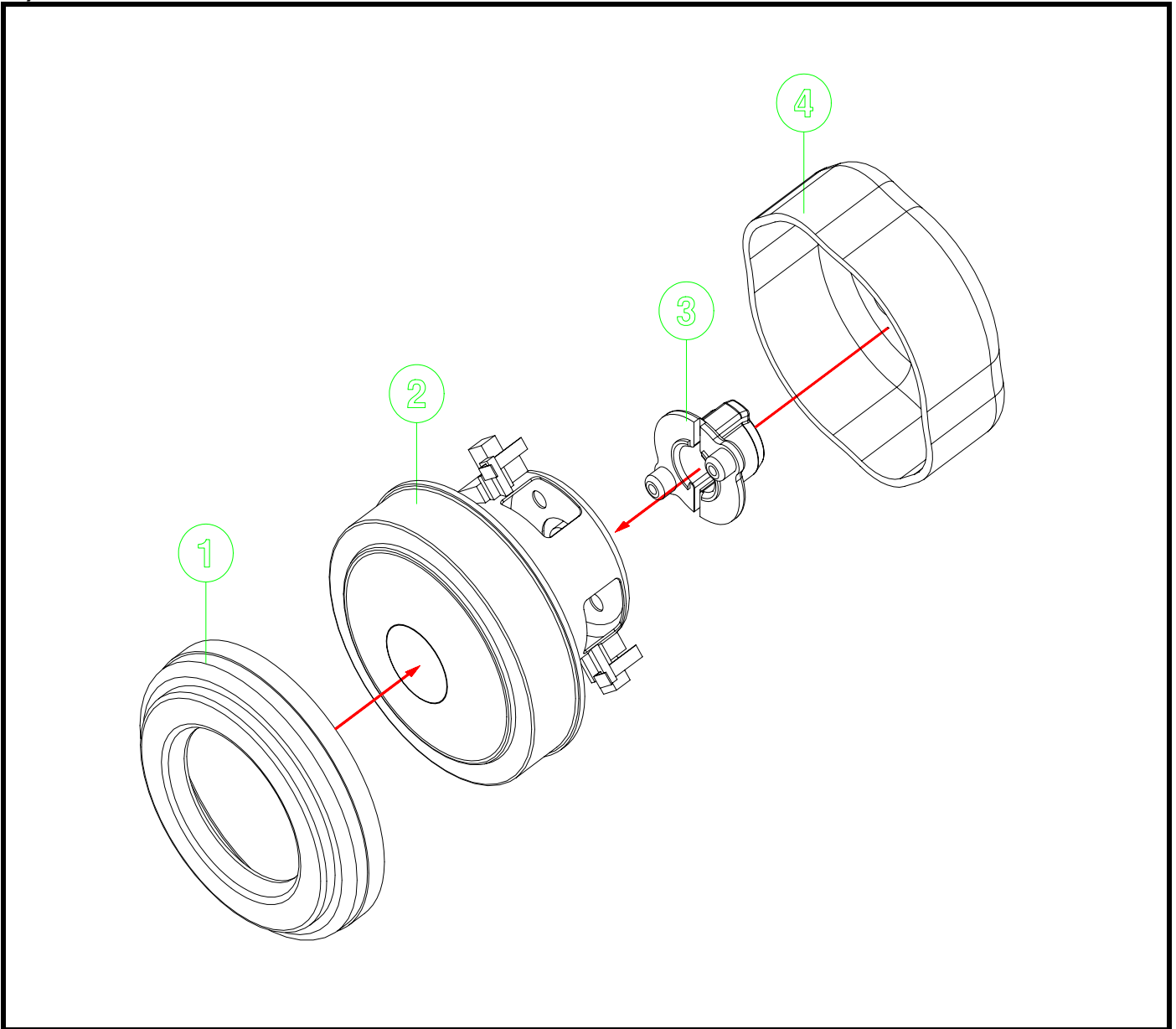

NO	PART NAME	PART CODE	SPECS.	Q'YT
1	MOTOR UNIVERSAL	3962511830	1600W 230V DMI VH122C6110	1
2	PACKING MOTOR	3624009200	NR FOAM	1
3	MOUNT MOTOR	362790090S	TPE	1
4	GUIDE AIR		PP(OPTIONAL)	1

6-7. CORDREEL ASSEMBLY

1) MODEL RC-4008B (3629508400)

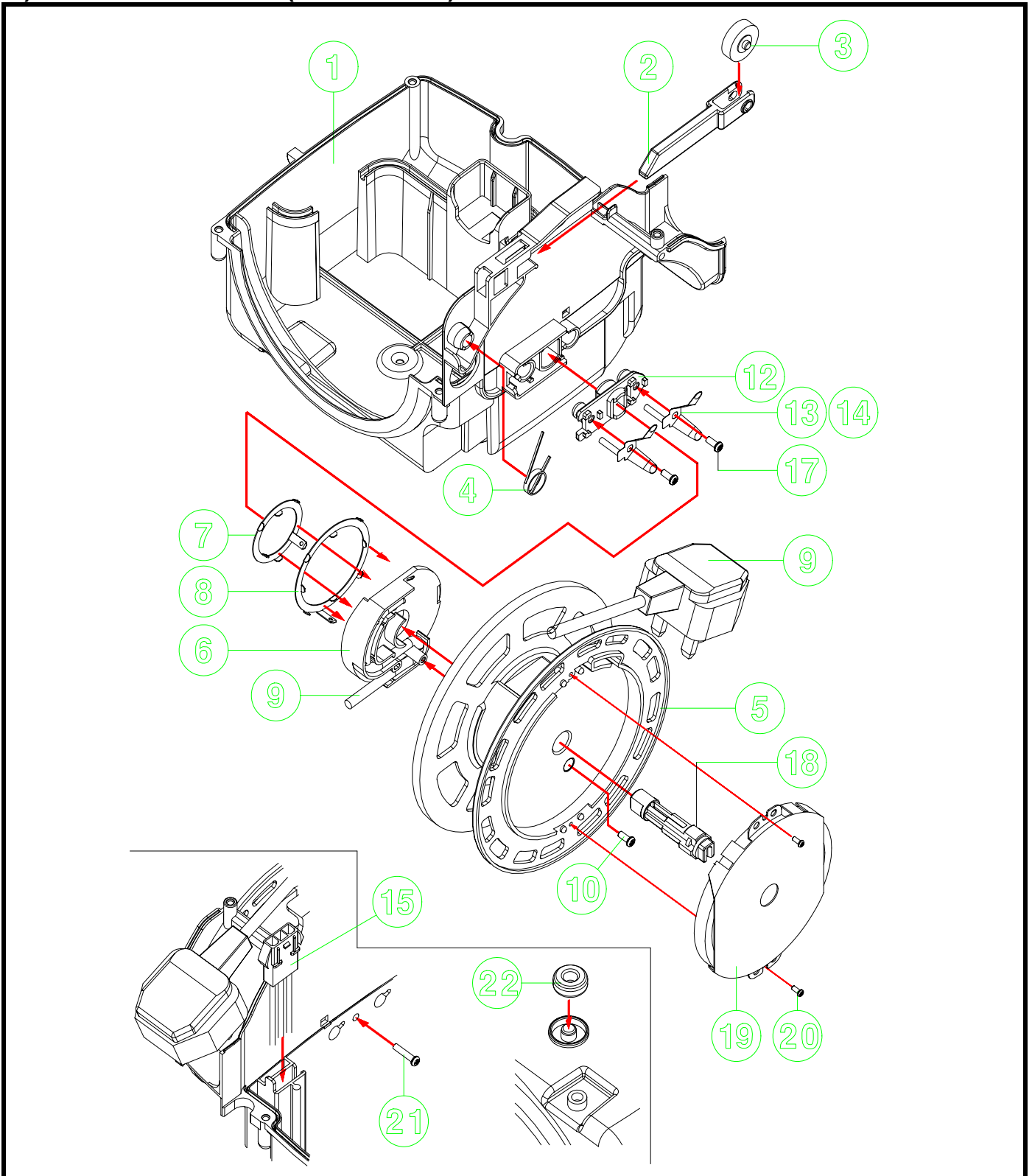

✓ **Caution** : In this Service Manual, some parts can be changed for improving, their performance without notice in the parts list. So, if you need the latest parts information, please refer to PPL(Parts Price List) in Service Information Center (<http://svc.dwe.co.kr>).

NO	PART NAME	PART CODE	SPECS.	Q'YT
1	CASE MOTOR BOTTOM	3621107200	PP	1
2	LEVER CR	3623702200	ABS	1
3	STOPPER ASSY	3625200200	ASSY	1
4	SPRING	3625103200	HSW3	1
5	BOBBIN	3629200600	PP	1
6	HOLDER TERMINAL	4565A36020	PP(5101SW,V-0)	1
7	TERMINAL	4565A36024	C2600P-1/2H T0.3	1
8	TERMINAL	4565A36034	C2600P-1/2H T0.3	1
9	CORD POWER	3621301750	HO5VVH2-F 5.4M	1
10	SCREW TAPPING	7121301011	T2S PAN 3X10 MFZN	1
11	WAX VASELINE	2291140301	VASELINE	0.002
12	SUPPORTER TERMINAL	3625300500	PP(5101SW)	1
13	TERMINAL Y AS	3628714800	TERMINAL+WIRE(WH)	1
14	TERMINAL Y AS	3628714900	WIRE(BK)	1
15	HARNES	3622715800	WIRE(WH,BK)+TER+HOUSING	1
16	CEC	4505A63040	ST CE-550(BIG)	1
17	SCREW TAPPING	7121400811	T2S PAN 4X8 MFZN	2
18	SHAFT REEL	3624900510	PC	1
19	SPRING AS	3625102000	SUS301-EH+COVER,3500MM	1
20	SCREW TAPPING	7121300811	T2S PAN 3X8 MFZN	2
21	SCREW TAPPING	7121401411	T2S PAN 4X14 MFZN	1
22	ABSORBER VIBRATION	3620112800	NR	1

✓ **Caution** : In this Service Manual, some parts can be changed for improving, their performance without notice in the parts list. So, if you need the latest parts information, please refer to PPL(Parts Price List) in Service Information Center (<http://svc.dwe.co.kr>).

NO	PART NAME	PART CODE	SPECS.	Q'YT
1	CASE MOTOR UPPER	3621107100	PP	1
2	PCB SLIDE VOLUME AS	3624303900	200K HOSE AS	1
3	SCREW TAPPING	7121301011	T2S PAN 3X10 MFZN	1
4	SWITCH PUSH	3629002000	7A/250V,(SKT)	1
5	PCB POWER CONTROL AS	3624315000	RC-400 220~240V/50HZ	1
6	COVER PCB	3621437100	PP	1
7	SCREW TAPPING	7121401011	T2S PAN 4X10 MFZN	3
8	FILTER OUTLET	3621909400	PE(T=3)	1
9	SCREW TAPPING	7121401411	T2S PAN 4X14 MFZN	4

6-9. HOSE ASSEMBLY

1) MODEL RC-4008B (3623210600)

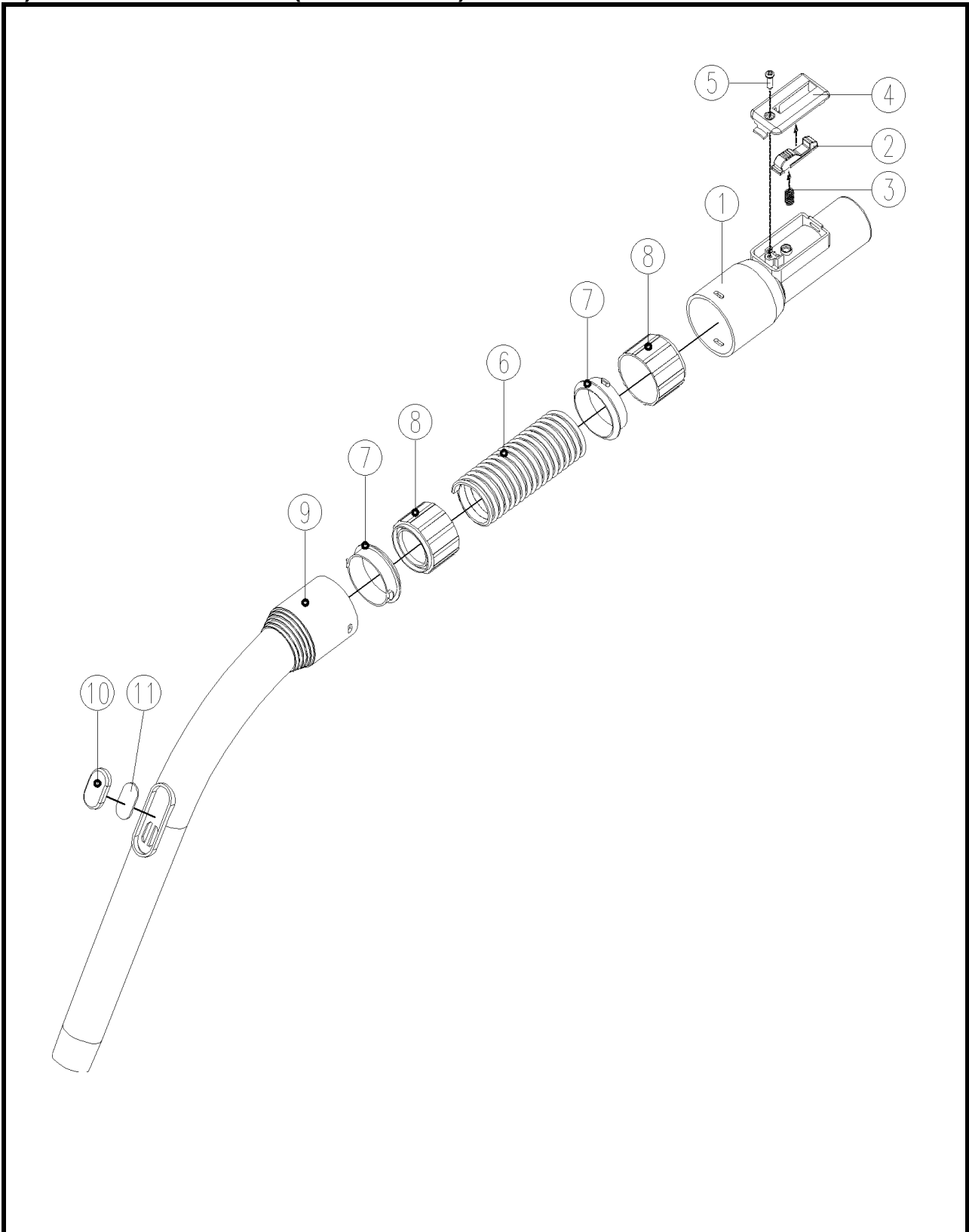

✓ **Caution** : In this Service Manual, some parts can be changed for improving, their performance without notice in the parts list. So, if you need the latest parts information, please refer to PPL(Parts Price List) in Service Information Center (<http://svc.dwe.co.kr>).

NO	PART NAME	PART CODE	SPECS.	Q'YT
1	ADAPTER PIPE	3629101000	ABS	1
2	CLAMP ADAPTER	3621200900	ABS	1
3	SPRING	3625102900	HSW3	1
4	COVER ADAPTER	3621412400	ABS	1
5	SCREW TAPPING	7121300812	T2S PAN 3X8 MFZN BK	1
6	HOSE	3623207200	EVA 1.6M	1.4
7	HOLDER HOSE	4569A71021	PP	2
8	CUFF HOSE	3626800200	HDPE	2
9	PIPE HOSE	3624408200	PP	1
10	VALVE AIR	3625400400	PP	1
11	PACKING HOLE	3624005900	EVA FOAM	1

✓ **Caution** : In this Service Manual, some parts can be changed for improving, their performance without notice in the parts list. So, if you need the latest parts information, please refer to PPL(Parts Price List) in Service Information Center (<http://svc.dwe.co.kr>).

6-10. PIPE ASSEMBLY

1) MODEL RC-4008B

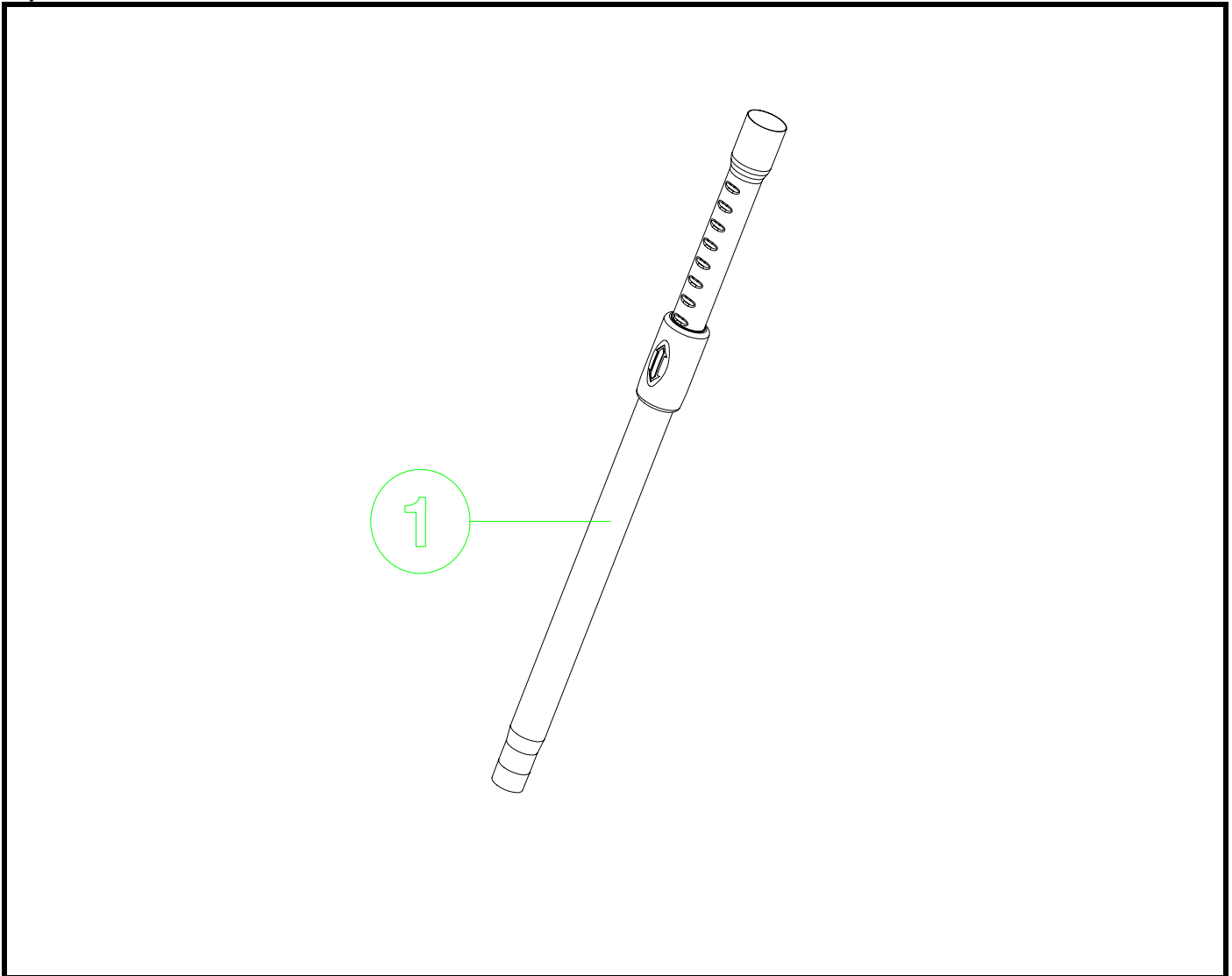

NO	PART NAME	PART CODE	SPECS.	Q'YT
1	PIPE	3624411470	SPC 0.7T	1

6-11. BRUSH ASSEMBLY

1) MODEL RC-4008B (3629306610)

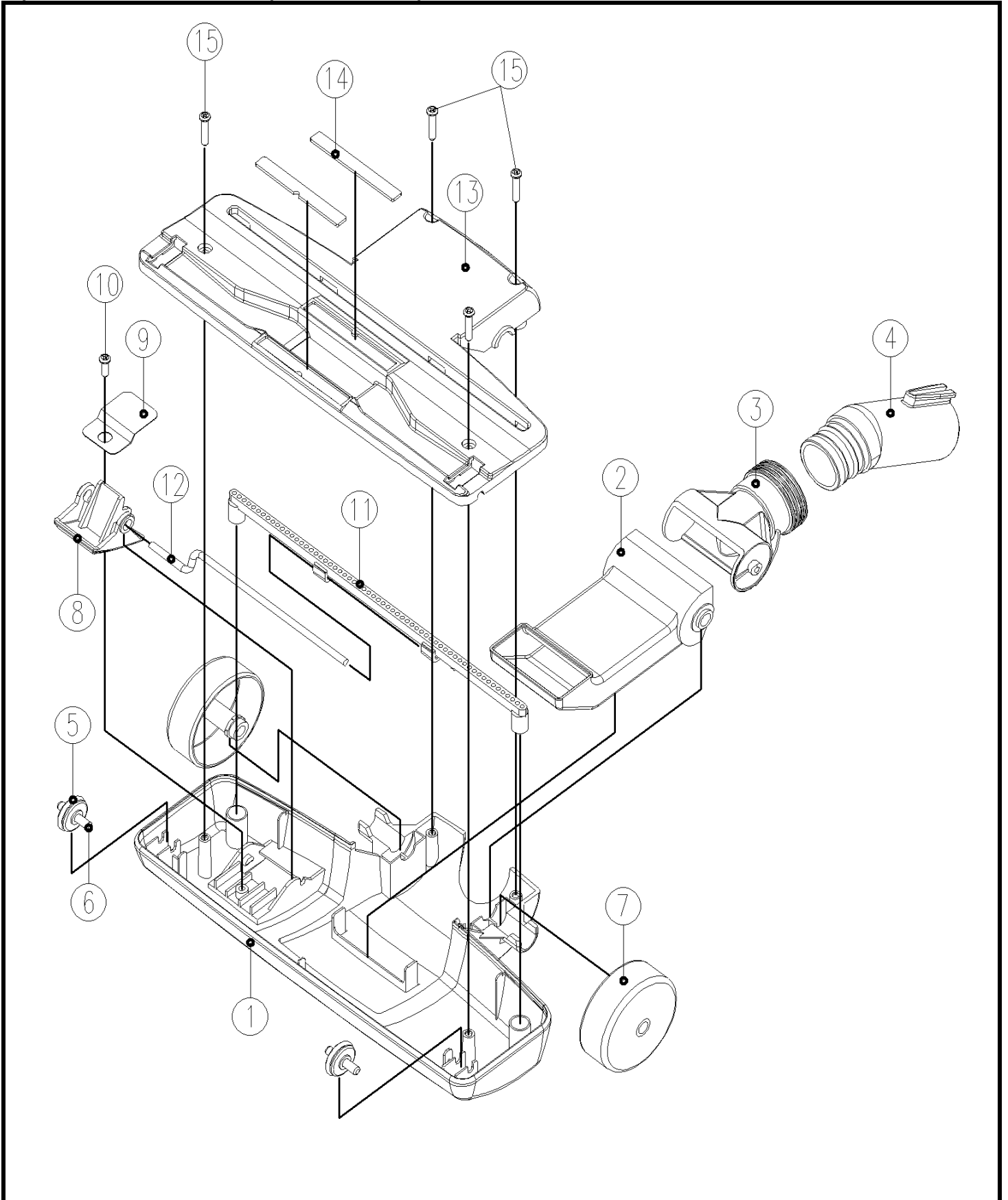

✓ **Caution** : In this Service Manual, some parts can be changed for improving, their performance without notice in the parts list. So, if you need the latest parts information, please refer to PPL(Parts Price List) in Service Information Center (<http://svc.dwe.co.kr>).

NO	PART NAME	PART CODE	SPECS.	Q'YT
1	COVER BRUSH	3621420800	PP	1
2	DUCT BRUSH	3629306300	PP	1
3	NECK BRUSH	3628002100	PP	1
4	PIPE BRUSH	3624408300	PP, CLEAN BR PIPE	1
5	ROLLER-F BRUSH	3624704310	PP	2
6	SHAFT ROLLER	3624900900	PA	2
7	ROLLER-B BRUSH	3624704400	PP	2
8	BUTTON BRUSH	3626604400	ABS	1
9	SPRING BUTTON	3625107300	SK-5,T=0.3	1
10	SCREW TAPPING	7128400811	T2S WAS 4X8 MFZN	1
11	SWEEPER BRUSH AS	3629306400	ASS'Y	1
12	SHAFT SWEEPER	3624901400	SWRM MFZN	1
13	BODY BRUSH	3620407800	PP	1
14	PICKER LITTER	3627000700	PA	2
15	SCREW TAPPTITE	7171401412	TT2 PAN 4X14 MFZN BK	4