

Service Manual

Microwave Oven

Model: KOC-9Q3T7S

KOC-9Q4T7S

KOC-9Q4T7WA9

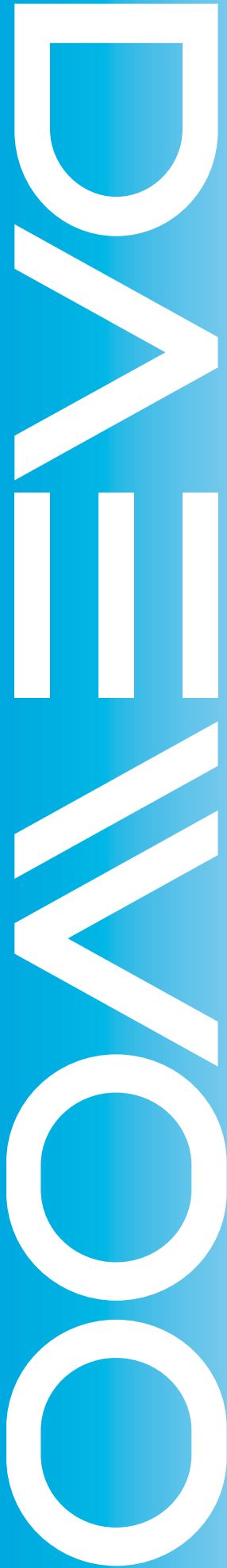

✓ **Caution**

: In this Manual, some parts can be changed for improving, their performance without notice in the parts list. So, if you need the latest parts information, please refer to PPL(Parts Price List) in Service Information Center (<http://svc.dwe.co.kr>).

PRECAUTIONS TO BE OBSERVED BEFORE AND DURING SERVICING TO AVOID POSSIBLE EXPOSURE TO EXCESSIVE MICROWAVE ENERGY

- (a) Do not operate or allow the oven to be operated with the door open.
- (b) Make the following safety checks on all ovens to be serviced before activating the magnetron or other microwave source, and make repairs if necessary: (1) Interlock operation, (2) Proper door closing, (3) Seal and sealing surfaces (arcing, wear, and other damage), (4) Damage to or loosening of hinges and latches (5) Evidence of dropping or abuse.
- (c) Before turning on power to the microwave oven for any service test or inspection within the microwave generating compartments, check the magnetron, wave guide or transmission line, and cavity for proper alignment, integrity, and connections.
- (d) Any defective or misadjusted components in the interlock, monitor, door seal and microwave generation and transmission systems shall be repaired, replaced, or adjusted by procedures described in this manual before the oven is released to the owner.

TABLE OF CONTENTS

1. SAFETY AND PRECAUTIONS	2
2. SPECIFICATIONS	3
3. EXTERNAL VIEW	4
3-1. OUTER DIMENSION	4
3-2. FEATURE DIAGRAM	5
4. INSTALLATION	6
5. CONTROL PANEL	7
6. DISASSEMBLY AND ASSEMBLY	8
7. INTERLOCK MECHANISM AND ADJUSTMENT	19
8. TROUBLE SHOOTING GUIDE	20
9. MEASUREMENT AND TEST	25
9-1. MEASUREMENT OF THE MICROWAVE POWER OUTPUT	25
9-2. MICROWAVE RADIATION TEST	26
9-3. COMPONENT TEST PROCEDURE	27
9-4. COMPONENT ACTION	28
10. WIRING DIAGRAM	29
11. EXPLODED VIEW AND PARTS LIST	30
11-1. DOOR ASSEMBLY	30
12-2. CONTROL PANEL ASSEMBLY	30
13-3. TOTAL ASSEMBLY	30
12. PRINTED CIRCUIT BOARD	31
13. P.C.B CIRCUIT DIAGRAM	38

1. SAFETY AND PRECAUTIONS

1. FOR SAFE OPERATION

Damage that allows the microwave energy (that cooks or heats the food) to escape will result in poor cooking and may cause serious bodily injury to the operator.

IF ANY OF THE FOLLOWING CONDITIONS EXIST, OPERATOR MUST NOT USE THE APPLIANCE. (Only a trained service personnel should make repairs.)

- 1) A broken door hinge.
- 2) A broken door viewing screen.
- 3) A broken front panel, oven cavity.
- 4) A loosened door lock.
- 5) A broken door lock.

The door gasket plate and oven cavity surface should be kept clean.

No grease, soil or spatter should be allowed to build up on these surfaces or inside the oven.

DO NOT ATTEMPT TO OPERATE THIS APPLIANCE WITH THE DOOR OPEN.

The microwave oven has concealed switches to make sure the power is turned off when the door is opened.

Do not attempt to defeat them.

DO NOT ATTEMPT TO SERVICE THIS APPLIANCE UNTIL YOU HAVE READ THIS SERVICE MANUAL.

2. FOR SAFE SERVICE PROCEDURES.

1. If the oven is operative prior to servicing, a microwave emission check should be performed prior to servicing the oven.
2. If any certified oven unit is found to servicing, a microwave emission check should be performed prior to servicing the oven.
 - (a) inform the manufacturer, importer or assembler,
 - (b) repair the unit at no cost to the owner,
 - (c) attempt to ascertain the cause of the excessive leakage,
 - (d) tell the owner of the unit not to use the unit until the oven has been brought into compliance.
3. If the oven operates with the door open, the service person should tell the user not to operate the oven and contact the manufacturer immediately.

IMPORTANT

The wire in this mains lead coloured in accordance with the following code.

Green-and-yellow	: Earth
Blue	: Neutral
Brown	: Live

As the colours of the wires in the mains lead of this appliance may not correspond with the coloured markings identifying the terminals in your plug, proceed as follows.

The wire which is coloured green-and-yellow must be connected to the terminal in the plug which is marked with the letter 'E' or by earth symbol or green-and-yellow.

The wire which is coloured blue must be connected to the terminal which is marked with the letter 'N' or coloured black.

The wire which is coloured brown must be connected to the terminal which is marked with the letter 'L' or coloured red.

NOTE : This oven is designed for counter-top use only.

2. SPECIFICATIONS

MODEL		KOC-9Q3T7S
POWER SUPPLY		230V~50Hz, SINGLE PHASE WITH EARTHING
POWER CONSUMPTION	MICROWAVE	1400W
	GRILL	1250W
	CONVECTION	1250W
	COMBINATION	2700W
MICROWAVE ENERGY OUTPUT		900W (IEC 705)
MICROWAVE FREQUENCY		2450MHz
OUTSIDE DIMENSIONS (W X D X H)		513X382X311mm(20.2X15X12.2 in.)
CAVITY DIMENSIONS (W X D X H)		354X341X231mm(13.9X13.4X9.1 in.)
NET WEIGHT		Approx. 16.6Kg (46.6 lbs.)
TIMER		60 minutes
FUNCTION SELECTIONS		Microwave / Grill / Convection / Combination
POWER SELECTIONS		10 LEVELS
CAVITY VOLUME		0.99 Cu. Ft

* SPECIFICATION ARE SUBJECT TO CHANGE WITHOUT NOTICE.

MODEL		KOC-9Q4T7S / 9Q4T7WA9
POWER SUPPLY		230V~50Hz, SINGLE PHASE WITH EARTHING
POWER CONSUMPTION	MICROWAVE	1400W
	GRILL	1250W
	CONVECTION	1250W
	COMBINATION	2700W
MICROWAVE ENERGY OUTPUT		900W (IEC 705)
MICROWAVE FREQUENCY		2450MHz
OUTSIDE DIMENSIONS (W X D X H)		513X383X311mm(20.2X15.1X12.2 in.)
CAVITY DIMENSIONS (W X D X H)		354X341X231mm(13.9X13.4X9.1 in.)
NET WEIGHT		Approx. 16.6Kg (46.6 lbs.)
TIMER		60 minutes
FUNCTION SELECTIONS		Microwave / Grill / Convection / Combination
POWER SELECTIONS		10 LEVELS
CAVITY VOLUME		0.99 Cu. Ft

* SPECIFICATION ARE SUBJECT TO CHANGE WITHOUT NOTICE.

3. EXTERNAL VIEW

1. OUTER DIMENSION

1) KOC-9Q3T7S

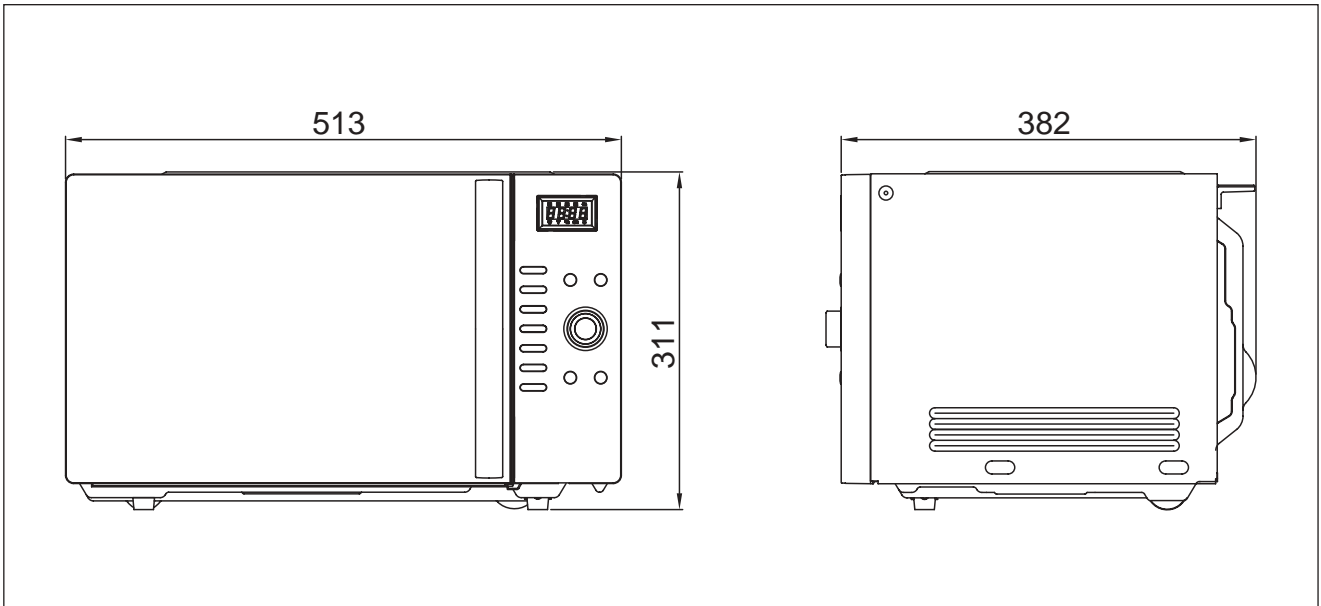

2) KOC-9Q4T7S / 9Q4T7WA9

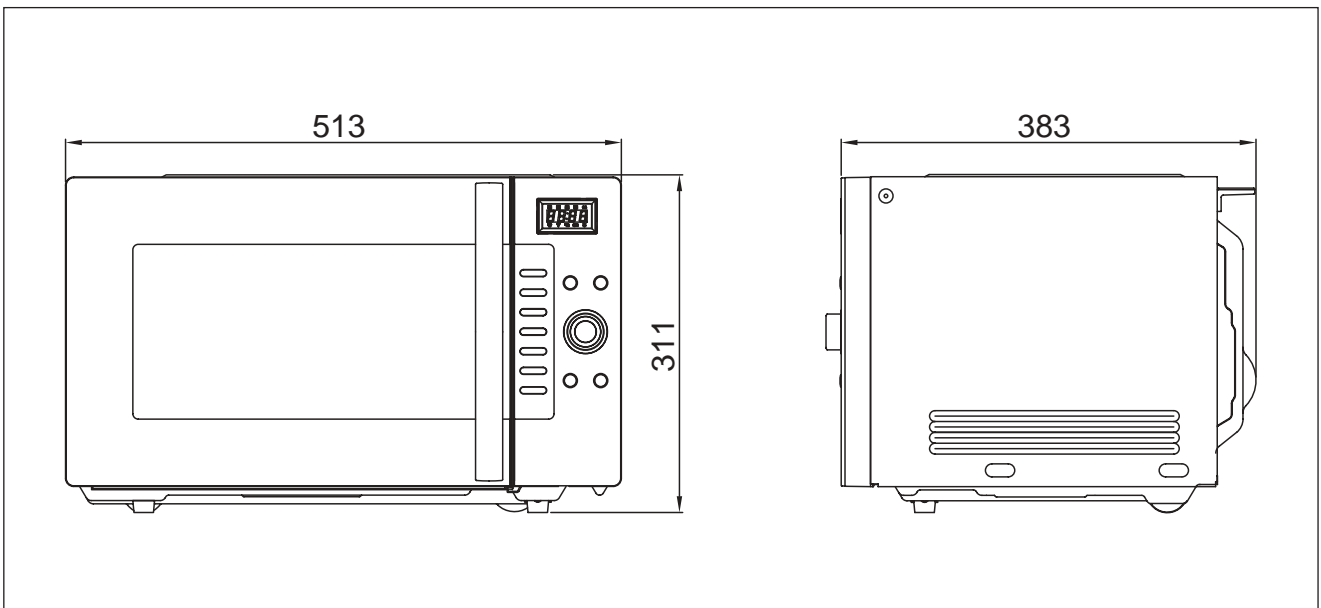

2. FEATURE DIAGRAM

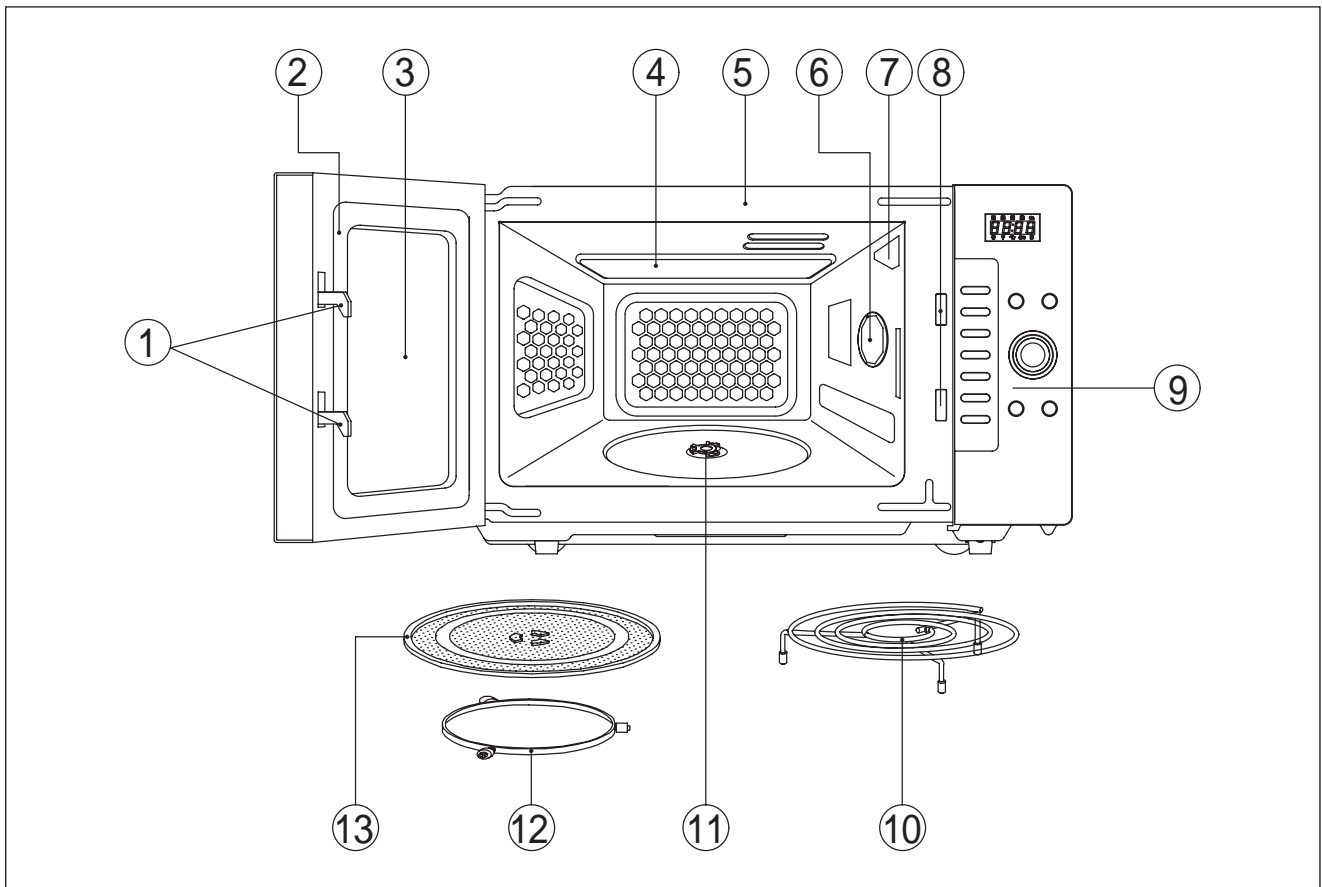

1. DOOR HOOK

Hook automatically locks and holds the door when the door shuts. If the door opens while the oven is operating, the oven will stop operating immediately.

2. DOOR SEAL

Door seal prevents the microwave leakage from the oven cavity.

3. DOOR VIEWING SCREEN

Food, inside of oven, can be observed through the door viewing screen. It is designed that the microwave cannot pass through the screen.

4. TOP HEATER

Top heater turns on if any of heater related mode operates.

5. OVEN FRONT PLATE

6. CONVECTION INLET

7. OVEN LAMP

Oven lamp turns on anytime the door opens and oven operates.

8. SAFETY INTERLOCK SYSTEM

9. CONTROL PANEL

10. METAL RACK

11. COUPLER

Coupler located at the center of the oven cavity and it couples between the motor and the glass tray.

12. ROLLER GUIDE

Roller guide must be used anytime with the glass tray.

13. GLASS TRAY

Glass tray is made of special heat resistant glass material. It must be always properly fitted with the coupler and the roller guide.

4. INSTALLATION

1. Steady, flat location

This microwave oven should be set on a steady, flat surface.
This microwave oven is designed for counter top use only.

2. Leave space behind and side

All air vents should be kept a clearance. If all vents are covered during operation, the oven may overheat and, eventually, cause failure.

3. Away from Radio and TV sets

Poor television reception and radio interference may result if the oven is located close to a TV, Radio, antenna or feeder and so on.
Position the oven as far from them as possible.

4. Away from heating appliances and water taps

Keep the oven away from hot air, steam or splash when choosing a place to position it, or the insulation might be adversely affected and breakdowns occur.

5. Power supply

- Check your local power source. This microwave oven requires a current of approximately 12 amperes, 230V, 50Hz.
- Power supply cord is about 1.0 meters long.
- The voltage used must be the same as specified on this oven. Using a higher voltage may result in a fire or other accident causing oven damage. Using low voltage will cause slow cooking. We are not responsible for damage resulting from use of this oven with a voltage of ampere fuse other than those specified.
- This appliance is supplied with cable of special type, which, if damaged, must be repaired with cable of same type. Such a cable can be purchased from DAEWOO and must be installed by a Qualified Person.

6. Examine the oven after unpacking for any damage such as:

A misaligned door, broken door or a dent in cavity.
If any of the above are visible, DO NOT INSTALL, and notify dealer immediately.

7. Do not operate the oven if it is colder than room temperature.

EARTHING INSTRUCTIONS

This appliance must be earthed. In the event of an electrical short circuit, earthing reduces the risk of the electric shock by providing an escape wire for the electric current. This appliance is equipped with a cord having a earthing wire with a earthing plug. The plug must be plugged into an outlet that is properly installed and earthed.

WARNING

Improper use of the earthing plug can result in a risk of electric shock. Consult a qualified electrician or serviceman if the earthing instructions are not completely understood, or if doubt exists as to whether the appliance is properly earthed, and either:
If it is necessary to use an extension cord, use only a 3-wire extension cord that has a 3-blade earthing plug, and a 3-slot receptacle that will accept the plug on the appliance.
The marked rating of the extension cord should be equal to or greater than the electrical rating of the appliance, or
Do not use an extension cord.

5. CONTROL PANEL

1) KOC-9Q3T7S

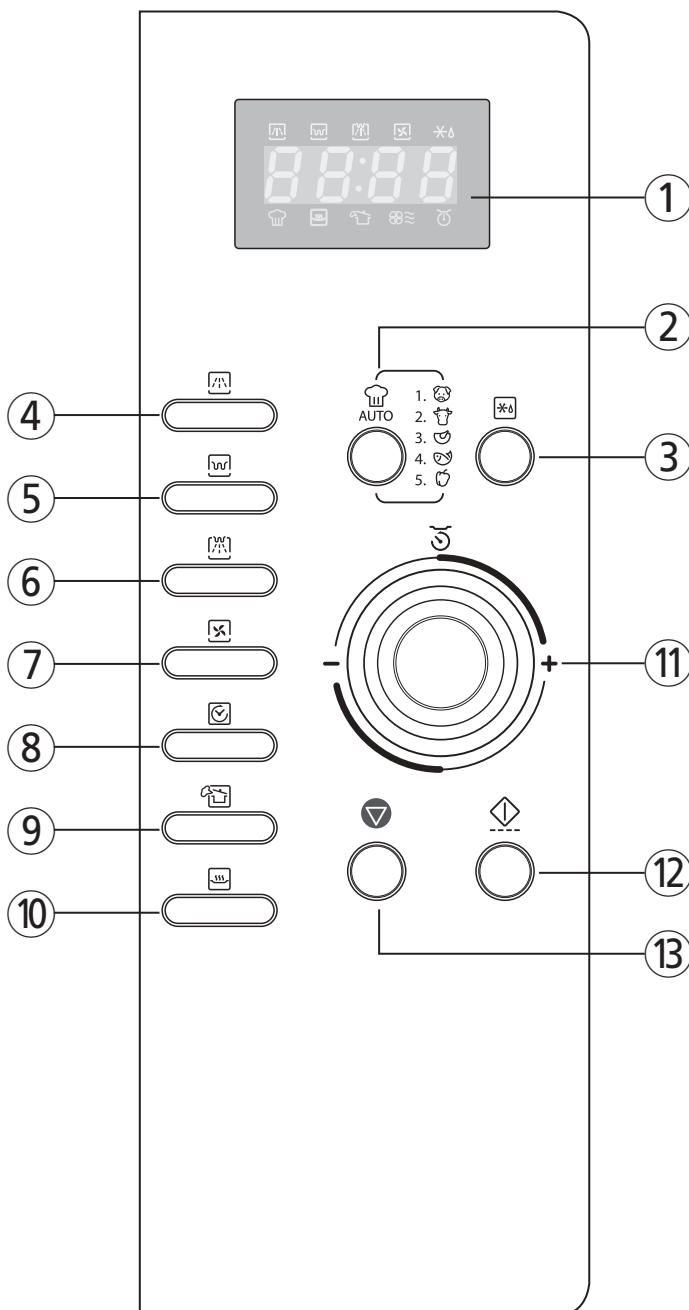

- ① **Display** : Cooking time, power level, program indicators and present time are displayed.
 MW (☰): When blinking, the oven is operating in MICROWAVE COOK mode.
 Grill (☷): When blinking, the oven is operating in GRILL mode.
 Combi (☶): When blinking, the oven is operating in COMBI mode.
 Convection (☱): When blinking, the oven is operating in CONVECTION mode.
 Defrost (*): When blinking, the oven is operating in DEFROST mode.
 Auto-cook (🏠): When blinking, the oven is operating in AUTO COOK mode.
 Warm (🔥): When blinking, the oven is operating in WARM mode.
 Steam Cleaning (☁): When blinking, the oven is operating in STEAM CLEANING mode.
 gram (⚖): When blinking, the oven is operating in weight input mode.
- ② **Auto cook** : Used to cook or reheat.
- ③ **Defrost** : Used to defrost foods.
- ④ **MW** : Used to set power level of the microwave.
- ⑤ **Grill** : Used to select grill mode.
- ⑥ **Combi** : Used to select combi mode.
- ⑦ **Convection** : Used to select convection mode and selected temp.
- ⑧ **Clock** : Used to set clock.
- ⑨ **STEAM CLEANING** : Used to clean the inside of the oven
- ⑩ **Warm** : Used to keep the food warm.
- ⑪ **Dial knob** : Used to set time, weight and quantity.
- ⑫ **START/SPEEDY COOK** : Used to start a program or a speedy start(each press adds 30 seconds of microwave cooking time).
- ⑬ **STOP/CLEAR** : Used to stop the oven operation or to delete the cooking data.

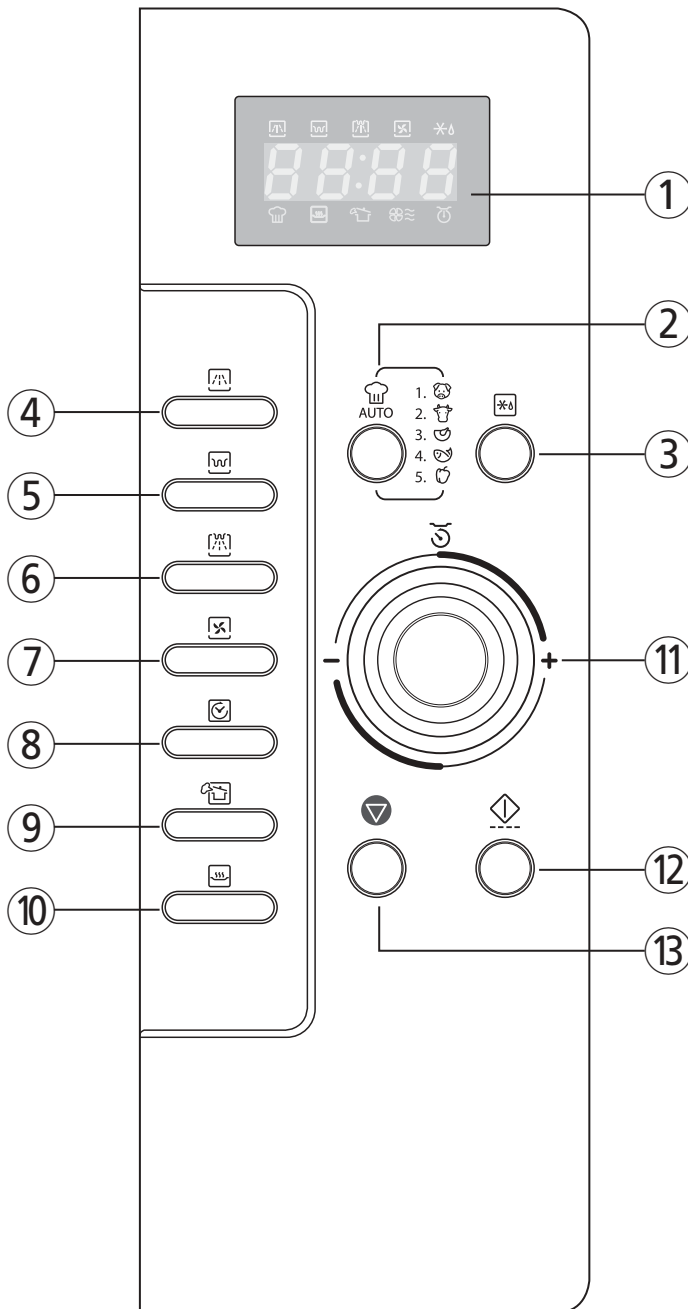

- ① **Display** : Cooking time, power level, program indicators and present time are displayed.
 MW (☐): When blinking, the oven is operating in MICROWAVE COOK mode.
 Grill (☐): When blinking, the oven is operating in GRILL mode.
 Combi (☐): When blinking, the oven is operating in COMBI mode.
 Convection (☐): When blinking, the oven is operating in CONVECTION mode.
 Defrost (*): When blinking, the oven is operating in DEFROST mode.
 Auto-cook (☐): When blinking, the oven is operating in AUTO COOK mode.
 Warm (☐): When blinking, the oven is operating in WARM mode.
 Steam Cleaning (☐): When blinking, the oven is operating in STEAM CLEANING mode.
 gram (☐): When blinking, the oven is operating in weight input mode.
- ② **Auto cook** : Used to cook or reheat.
- ③ **Defrost** : Used to defrost foods.
- ④ **MW** : Used to set power level of the microwave.
- ⑤ **Grill** : Used to select grill mode.
- ⑥ **Combi** : Used to select combi mode.
- ⑦ **Convection** : Used to select convection mode and selected temp.
- ⑧ **Clock** : Used to set clock.
- ⑨ **STEAM CLEANING** : Used to clean the inside of the oven.
- ⑩ **Warm or Dish Warm** : Used to keep the food or dish warm.
- ⑪ **Dial knob** : Used to set time, weight and quantity.
- ⑫ **START/SPEEDY COOK** : Used to start a program or a speedy start(each press adds 30 seconds of microwave cooking time).
- ⑬ **STOP/CLEAR** : Used to stop the oven operation or to delete the cooking data.

6. DISASSEMBLY AND ASSEMBLY

- Cautions to be observed when trouble shooting.

Unlike many other appliances, the microwave oven is high-voltage, high-current equipment.

It is completely safety during normal operation. However, carelessness in servicing the oven can result in an electric shock or possible danger from a short circuit.

You are asked to observe the following precautions carefully.

1. Always remove the power plug from the outlet before servicing.
2. Use an insulated screwdriver and ware rubber gloves when servicing the high voltage side.
3. Discharge the high voltage capacitor before touching any oven components or wiring.

(1) Check the earthed.

Do not operate on a two-wire extension cord.

The microwave oven is designed to be used with earthed.

It is imperative, therefore, to makes sure it is earthed properly before beginning repair work.

(2) Warning about the electric charge in the high voltage capacitor.

For about 30 seconds after the operation stopped and electric charge remains in the high voltage capacitor. When replacing or checking parts, short between oven chassis and the negative high terminal of the high voltage capacitor, by using a properly insulated screwdriver to discharge.

4. When the fuse is blown out due to the operation of the monitor switch; replace primary interlock switch, secondary interlock switch and interlock monitor switch.
5. After repair or replacement of parts, make sure that the screws are properly tightened, and all electrical connections are tightened.
6. Do not operate without cabinet.

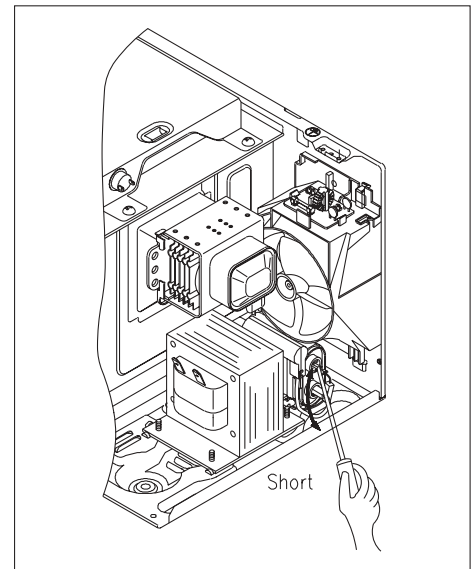

CAUTION : Service personnel should remove their watches whenever working close to or replacing the magnetron.

WARNING : When servicing the appliance, need a care of touching or replacing high potential parts because of electrical shock or exposing microwave. These parts are as follows - HV Transformer, Magnetron, HV Capacitor, HV Diode.

1. To remove cabinet

- 1) Remove five screws on cabinet back.
- 2) Push the cabinet backward.

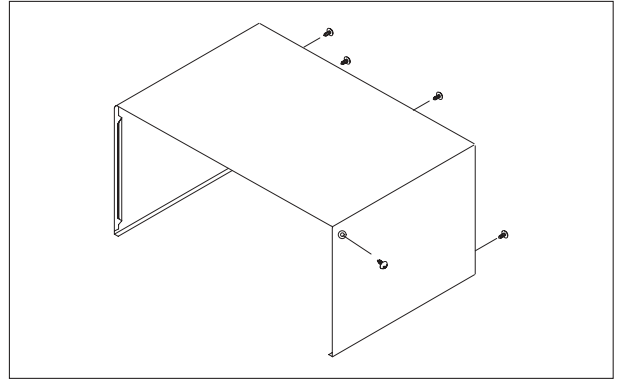

2. To remove door assembly

- 1) Remove two screws which secure the stopper hinge top.
- 2) Remove the door assembly from top plate of cavity.
- 3) Reverse the above for assembly.

NOTE: After replacing the door assembly, perform a check of correct alignment with the hinge and cavity front plate.

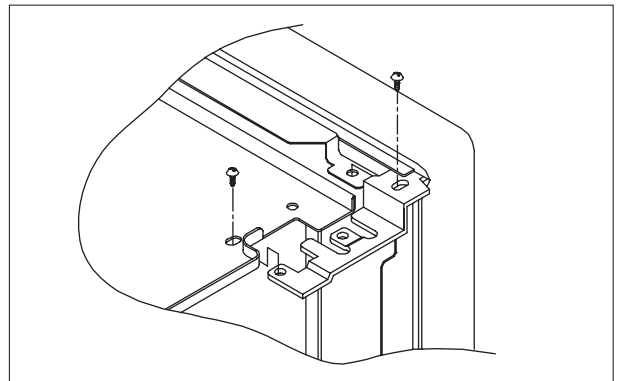

✓ **Caution** : In this Manual, some parts can be changed for improving, their performance without notice in the parts list.
 So, if you need the latest parts information, please refer to PPL(Parts Price List) in Service Information Center
 (<http://svc.dwe.co.kr>).

3. To remove door parts.

1) KOC-9Q3T7S

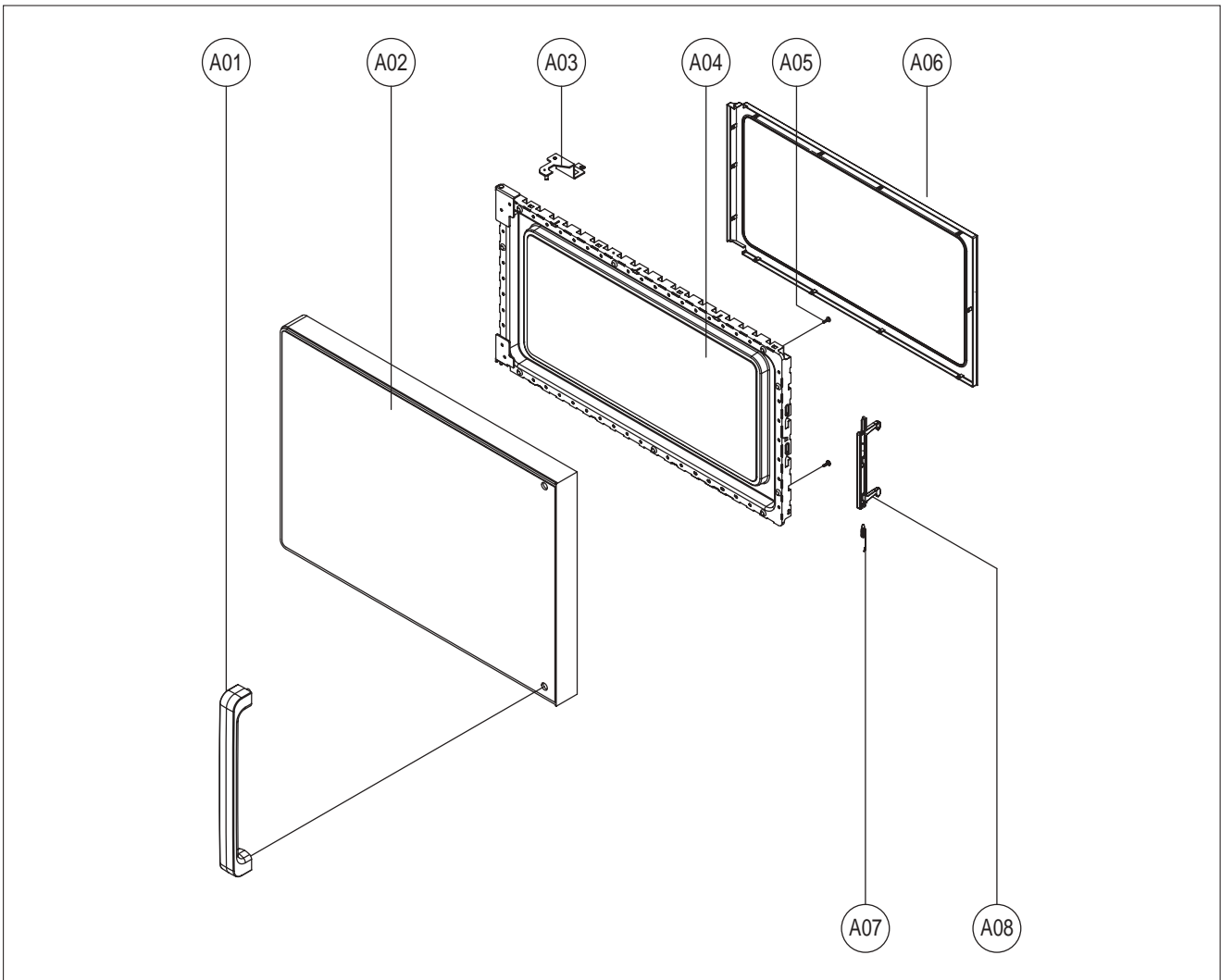

REF. NO	PART CODE	PART NAME	DESCRIPTION	Q'TY
B01	3512607710	HANDLE DOOR	ABS SG-0760D, SG-175 SPRAY	1
B02	3512209640	FRAME DOOR	ABS XR-401	1
B03	3515204120	STOPPER HINGE *T AS	KOR-6L0B1A	1
B04	3516603100	DOOR-PLATE	SECC 0.5T	1
B05	7122401211	SCREW TAPPING	T2S TRS 4X12 MFZN	2
B06	3512302410	GASKET DOOR	LUPOL 2300	1
B07	3515101310	SPRING HOOK	HSW-2	1
B08	3513101900	HOOK	POM	1

- (1) Remove the GASKET DOOR from DOOR AS.
- (2) Remove screws from DOOR AS.
- (3) Remove the HANDLE DOOR from DOOR AS.
- (4) Remove the DOOR-PALTE from FRAME DOOR.
- (5) Remove the STOPPER HINGE *T AS from DOOR-PLATE.
- (6) Remove the SPRING HOOK and the HOOK.
- (7) Reverse the above steps for reassembly.

✓ **Caution** : In this Manual, some parts can be changed for improving, their performance without notice in the parts list. So, if you need the latest parts information, please refer to PPL(Parts Price List) in Service Information Center (<http://svc.dwe.co.kr>).

2) KOC-9Q4T7S / 9Q4T7WA9

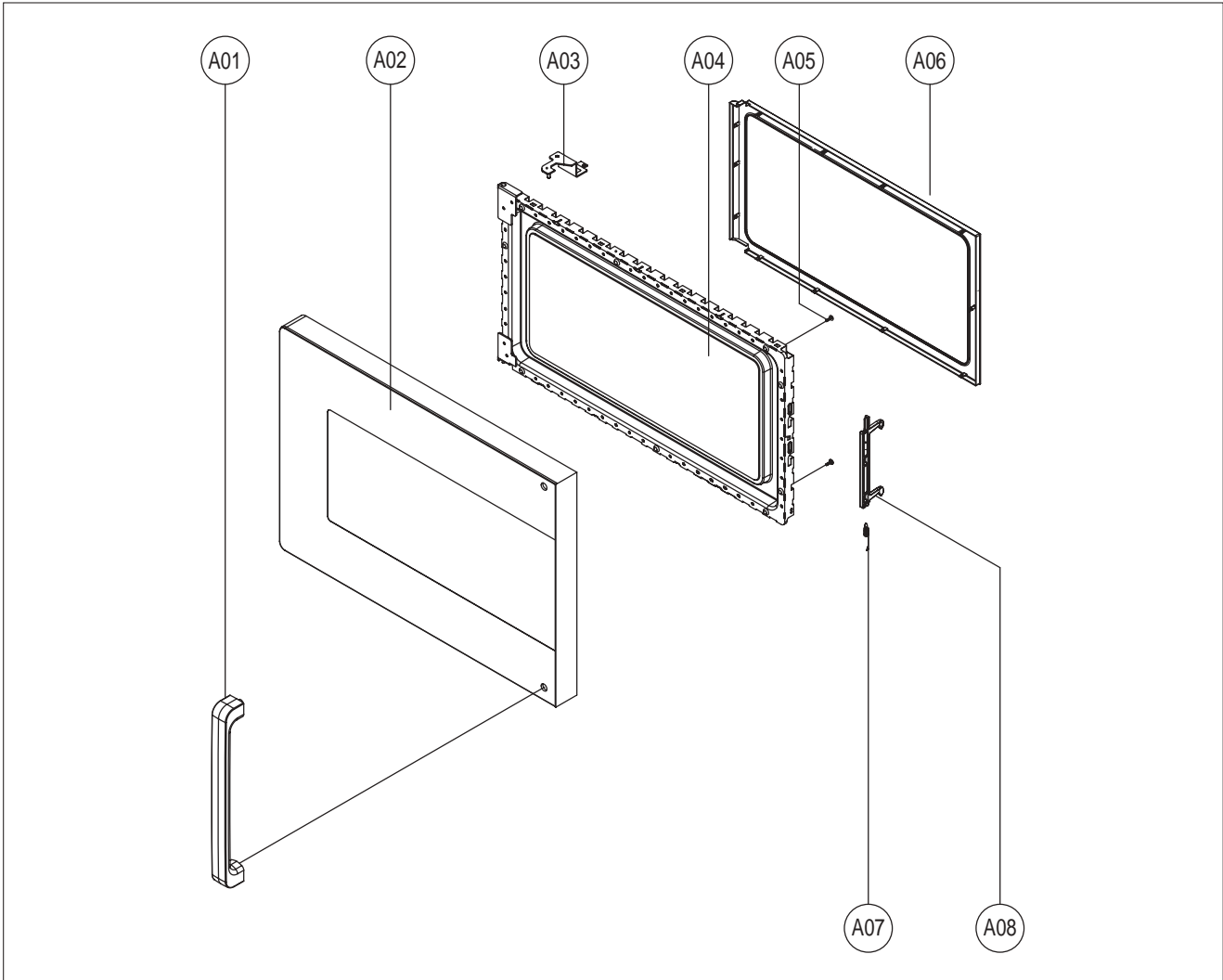

REF. NO	PART CODE	PART NAME	DESCRIPTION	Q'TY
B01	3512607710	HANDLE DOOR	ABS SG-0760D, SG-175 SPRAY	1
B02	3512209640	FRAME DOOR	ABS XR-401	1
B03	3515204120	STOPPER HINGE *T AS	KOR-6L0B1A	1
B04	3516603100	DOOR-PLATE	SECC 0.5T	1
B05	7122401211	SCREW TAPPING	T2S TRS 4X12 MFZN	2
B06	3512302410	GASKET DOOR	LUPOL 2300	1
B07	3515101310	SPRING HOOK	HSW-2	1
B08	3513101900	HOOK	POM	1

- (1) Remove the GASKET DOOR from DOOR AS.
- (2) Remove screws from DOOR AS.
- (3) Remove the HANDLE DOOR from DOOR AS.
- (4) Remove the DOOR-PALTE from FRAME DOOR.
- (5) Remove the STOPPER HINGE *T AS from DOOR-PLATE.
- (6) Remove the SPRING HOOK and the HOOK.
- (7) Reverse the above steps for reassembly.

4. Method to reduce the gap between the door seal and the oven front surface.

- (1) To reduce gap located on part 'A'.
 - Loosen two screws on stopper hinge top, and then push the door to contact the door seal to oven front surface.
 - Tighten two screws.
- (2) To reduce gap located on part 'B'.
 - Loosen two screws on stopper hinge under, and then push the door to contact the door seal to oven front surface.
 - Tighten two screws.

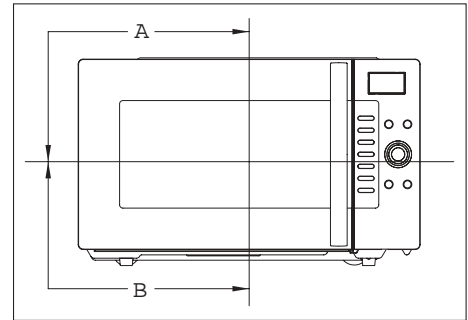

NOTE : A small gap may be acceptable if the microwave leakage does not exceed $4\text{mW}/\text{cm}^2$.

✓ **Caution** : In this Manual, some parts can be changed for improving, their performance without notice in the parts list. So, if you need the latest parts information, please refer to PPL(Parts Price List) in Service Information Center (<http://svc.dwe.co.kr>).

5. To remove control panel parts.

1) KOC-9Q3T7S

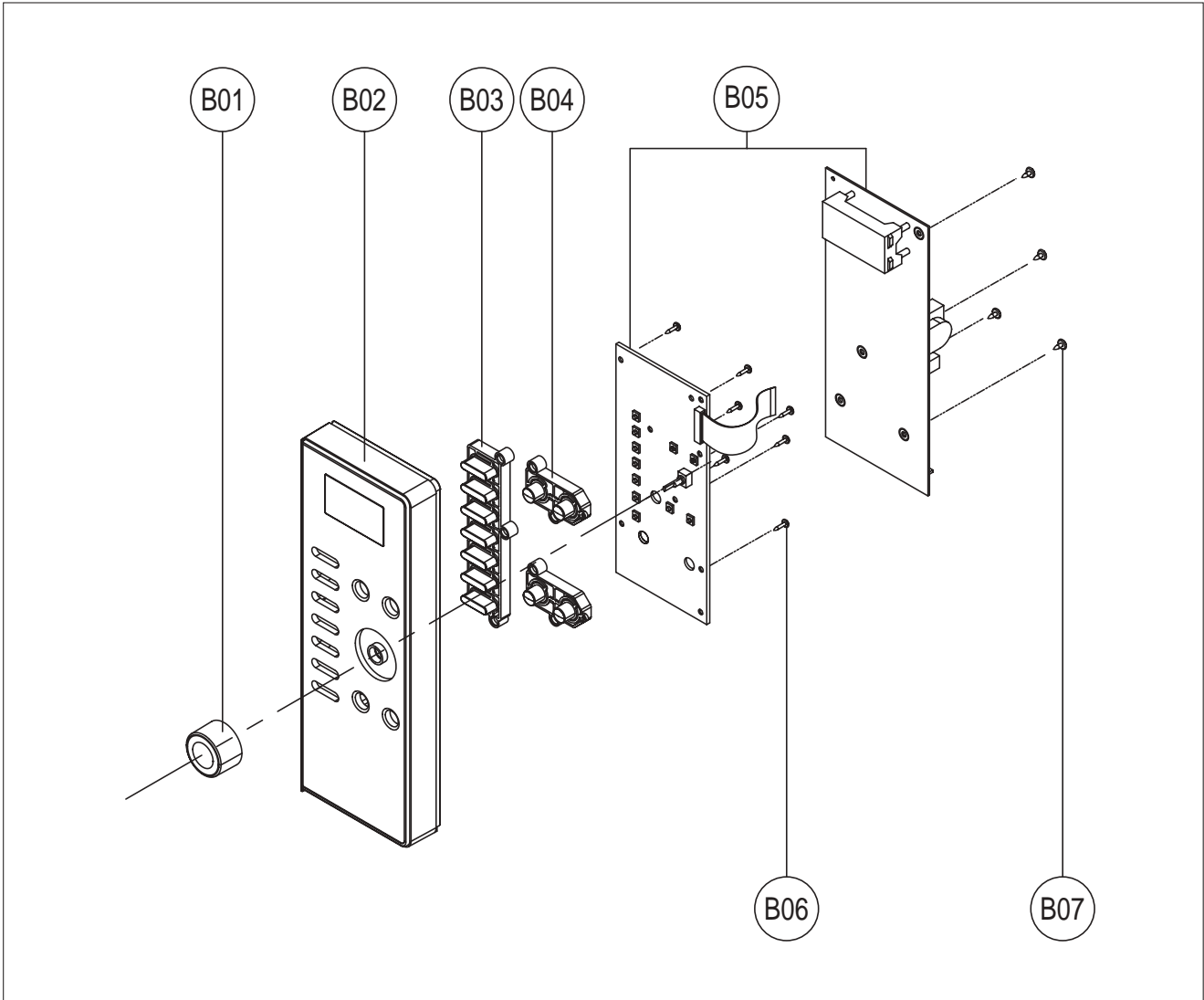

REF. NO	PART CODE	PART NAME	DESCRIPTION	Q'TY
B01	3513412110	KNOB DIAL	ABS SG-0760D, SG-175	1
B02	3516737190	CONROL-PANEL	ABS SG-0760D, SG-175	1
B03	3516912730	BUTTON FUNCTION-A	ABS SG-0760D, SG-175	1
B04	7122401211	SCREW TAPPING	T2S TRS 4X12 MFZN	4
B05	3514332650	PCB MAIN AS	KOC-9Q4T7S	1
B06	7121301011	SCREW TAPPING	T2S PAN 3X10 MFZN	9
B07	7122401211	SCREW TAPPING	T2S TRS 4X12 MFZN	4

- (1) Pull out the KNOB DIAL from CONTROL-PANEL AS.
- (2) Remove screws securing the PCB MAIN AS.
- (3) Pull out the PCB MAIN AS.
- (4) Pull out the BUTTON FUNCTION A and B.
- (5) Reverse the above steps for reassembly.

✓ **Caution** : In this Manual, some parts can be changed for improving, their performance without notice in the parts list. So, if you need the latest parts information, please refer to PPL(Parts Price List) in Service Information Center (<http://svc.dwe.co.kr>).

2) KOC-9Q4T7S / 9Q4T7WA9

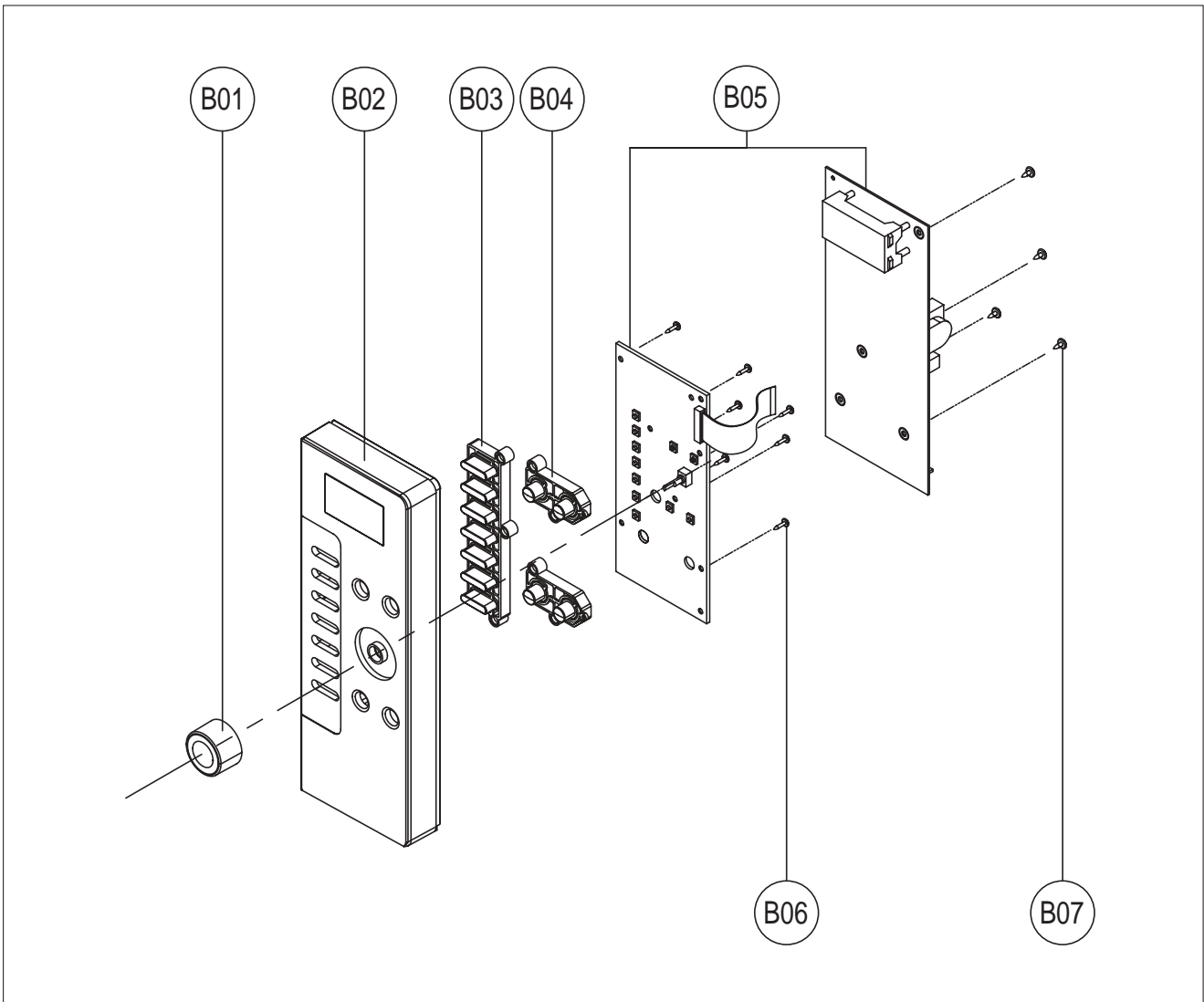

REF. NO	PART CODE	PART NAME	DESCRIPTION	Q'TY
B01	3513412110	KNOB DIAL	ABS SG-0760D, SG-175	1
B02	3516737190	CONROL-PANEL	ABS SG-0760D, SG-175	1
B03	3516912730	BUTTON FUNCTION-A	ABS SG-0760D, SG-175	1
B04	7122401211	SCREW TAPPING	T2S TRS 4X12 MFZN	4
B05	3514332650	PCB MAIN AS	KOC-9Q4T7S	1
	3514334700		KOC-9Q4T7WA9	1
B06	7121301011	SCREW TAPPING	T2S PAN 3X10 MFZN	9
B07	7122401211	SCREW TAPPING	T2S TRS 4X12 MFZN	4

- (1) Pull out the KNOB DIAL from CONTROL-PANEL AS.
- (2) Remove screws securing the PCB MAIN AS.
- (3) Pull out the PCB MAIN AS.
- (4) Pull out the BUTTON FUNCTION A and B.
- (5) Reverse the above steps for reassembly.

6. To remove high voltage capacitor.

- (1) Remove a screw which secure the grounding ring terminal of the H.V. diode and the capacitor holder.
- (2) Remove the H.V. diode from the capacitor holder.
- (3) Reverse the above steps for reassembly.

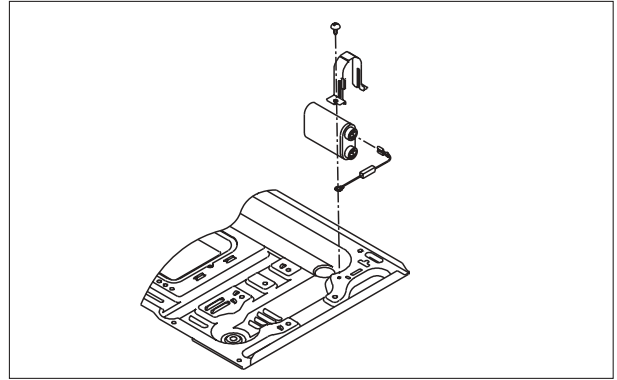

◆ High voltage circuit wiring

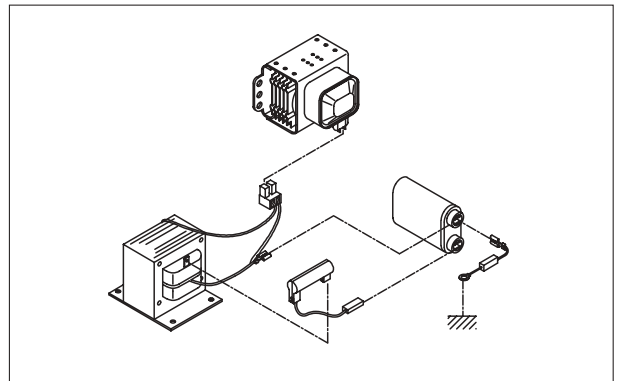

7. To remove magnetron.

- (1) Remove a screw which secure the magnetron.
- (2) Remove the magnetron.
- (3) Reverse the above steps for reassembly.

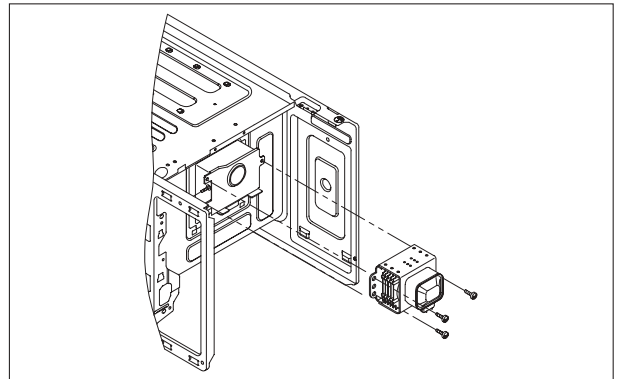

CAUTION : Never install the magnetron without the metallic gasket plate which is packed with each magnetron to prevent microwave leakage. Whenever repair work is carried out on magnetron, check the microwave leakage. It shall not exceed $4\text{mW}/\text{cm}^2$ for a fully assembled oven with door normally closed.

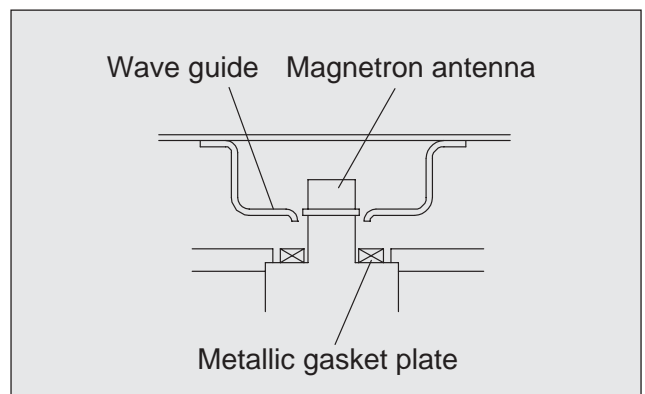
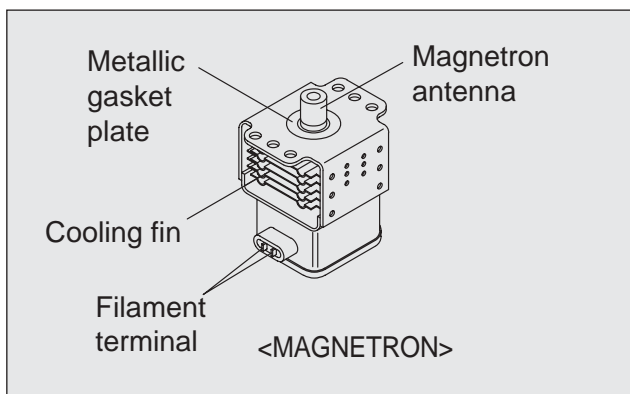

8. To remove wind guide assembly.

- 1) Remove a screw for earth.
- 2) Remove the noise filter from the wind guide.
- 3) Remove a screw which secure the wind guide assembly.
- 4) Draw forward the wind guide assembly.
- 5) Pull the fan from the motor shaft.
- 6) Remove two screws which secure the motor shaded pole.
- 7) Remove the motor shaded pole.
- 8) Reverse the above steps for reassembly.

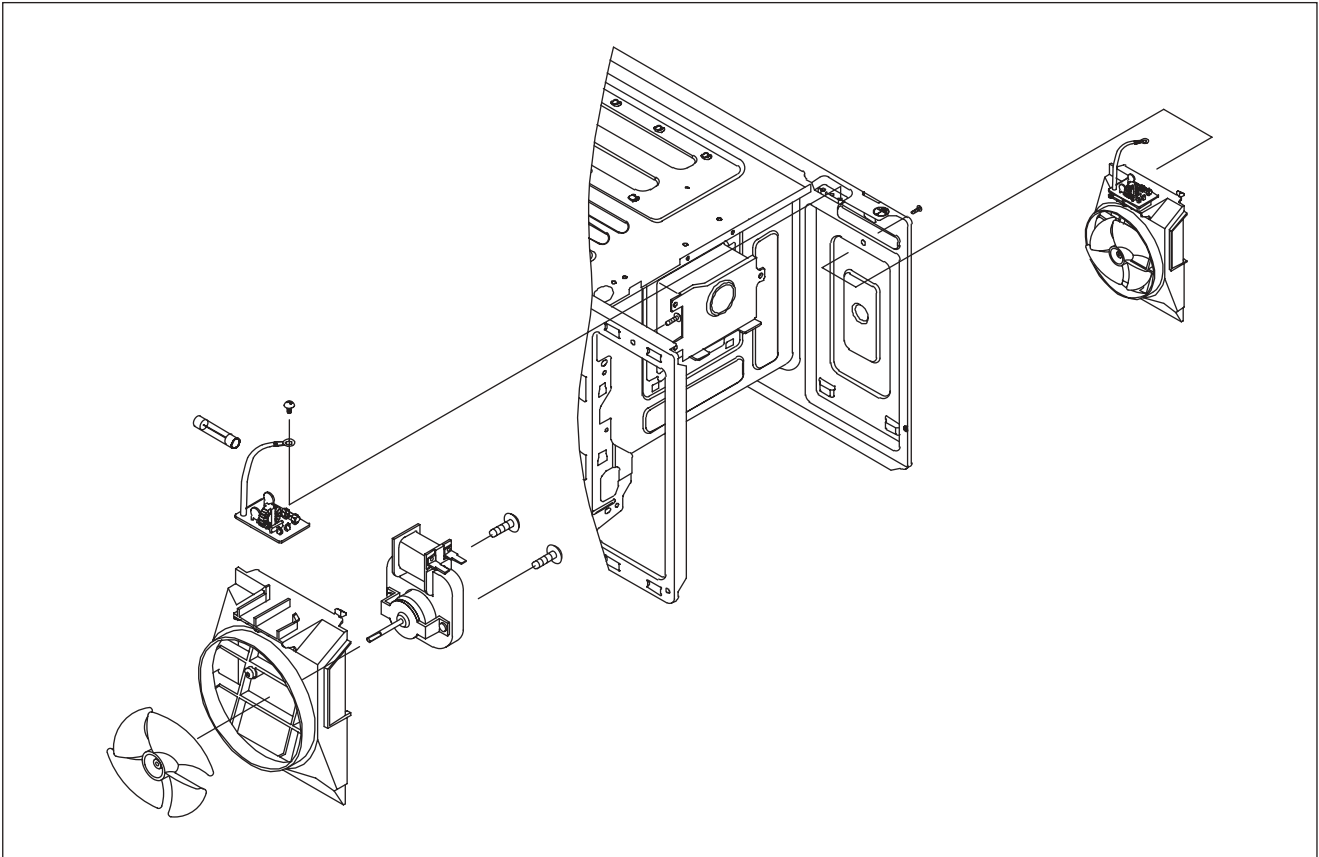

9. To remove H.V.transformer.

- 1) Remove four screws holding the H.V.transformer.
- 2) Remove the H.V.transformer.
- 3) Reverse the above steps for reassembly.

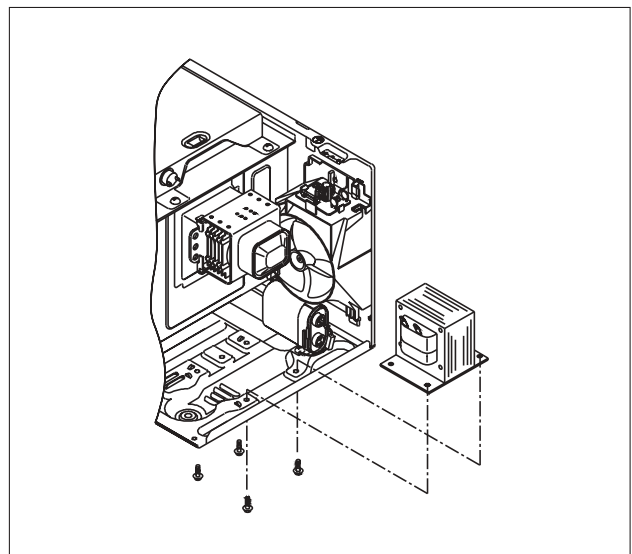

✓ **Caution** : In this Manual, some parts can be changed for improving, their performance without notice in the parts list. So, if you need the latest parts information, please refer to PPL(Parts Price List) in Service Information Center (<http://svc.dwe.co.kr>).

10. To remove fan convection assembly parts.

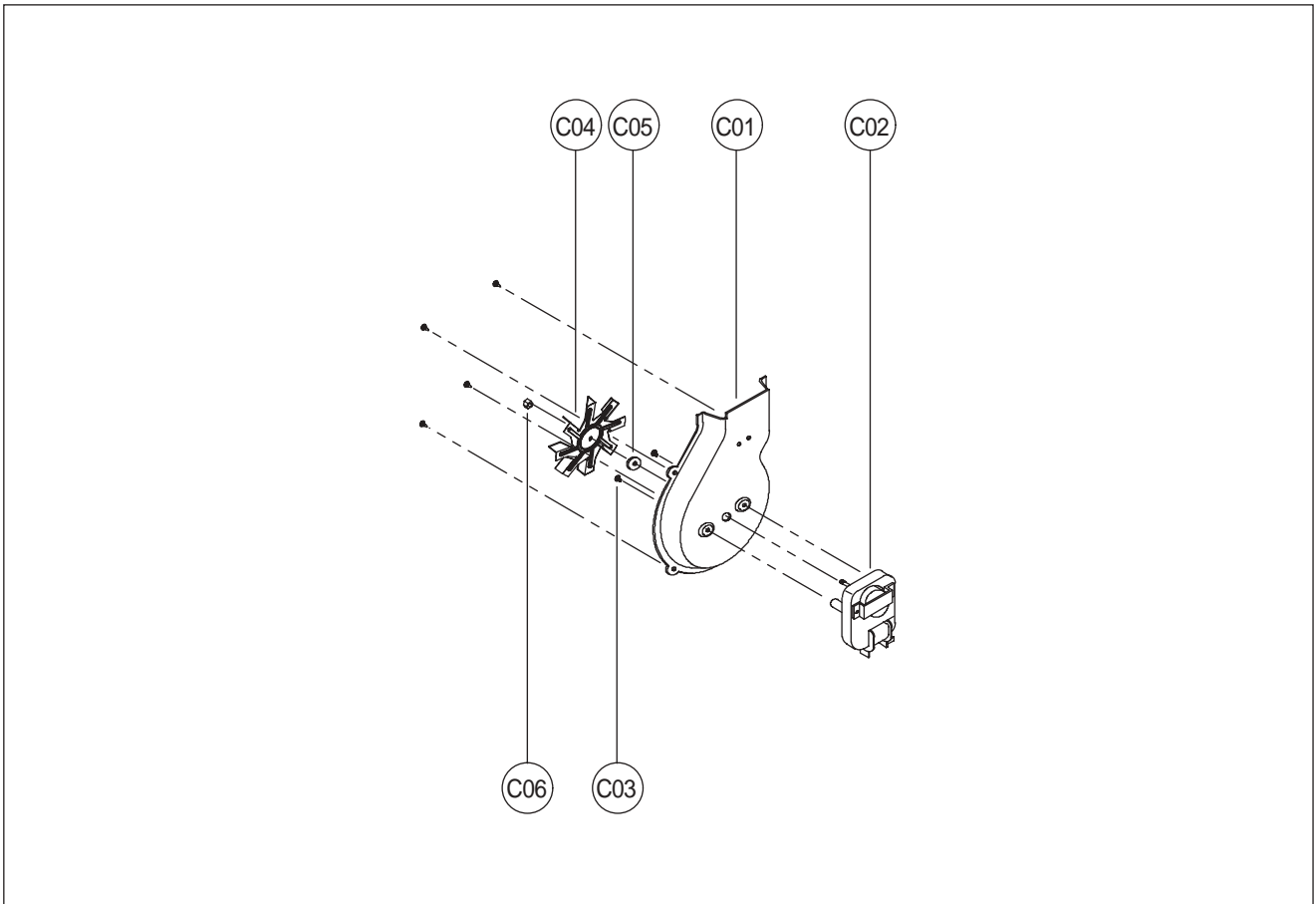

REF. NO	PART CODE	PART NAME	DESCRIPTION	Q'TY
H08	3511801400	FAN CONVECTION AS	KOC-9Q0T7S	1
C01	3511414400	COVER FAN CONVECTION	SBHG-2 T0.6	1
C02	3963511420	MOTOR SHADED POLE	230V 50HZ MW10CA-T04	1
C03	7S432X4081	SPECIAL SCREW	TT3 TRS 4X8 SE MFZN	2
C04	3511801200	FAN CONVECTION	SBHG T0.5	1
C05	7400104011	WASHER PLAIN	PW-1-4 MFZN	1
C06	7S627W40X1	NUT HEX	NUT FLANGE M4X0.7P MFZN	1

- (1) Remove four screws from the inside of cavity.
- (2) Remove NUT HEX at the center of the fan.
- (3) Remove WASHER PLAIN.
- (4) Remove two screws from the COVER FAN CONVECTION.
- (5) Pull out the MOTOR SHADED POLE.
- (6) Reverse the above steps for assembly.

✓ **Caution** : In this Manual, some parts can be changed for improving, their performance without notice in the parts list. So, if you need the latest parts information, please refer to PPL(Parts Price List) in Service Information Center (<http://svc.dwe.co.kr>).

11. To remove top heater assembly parts.

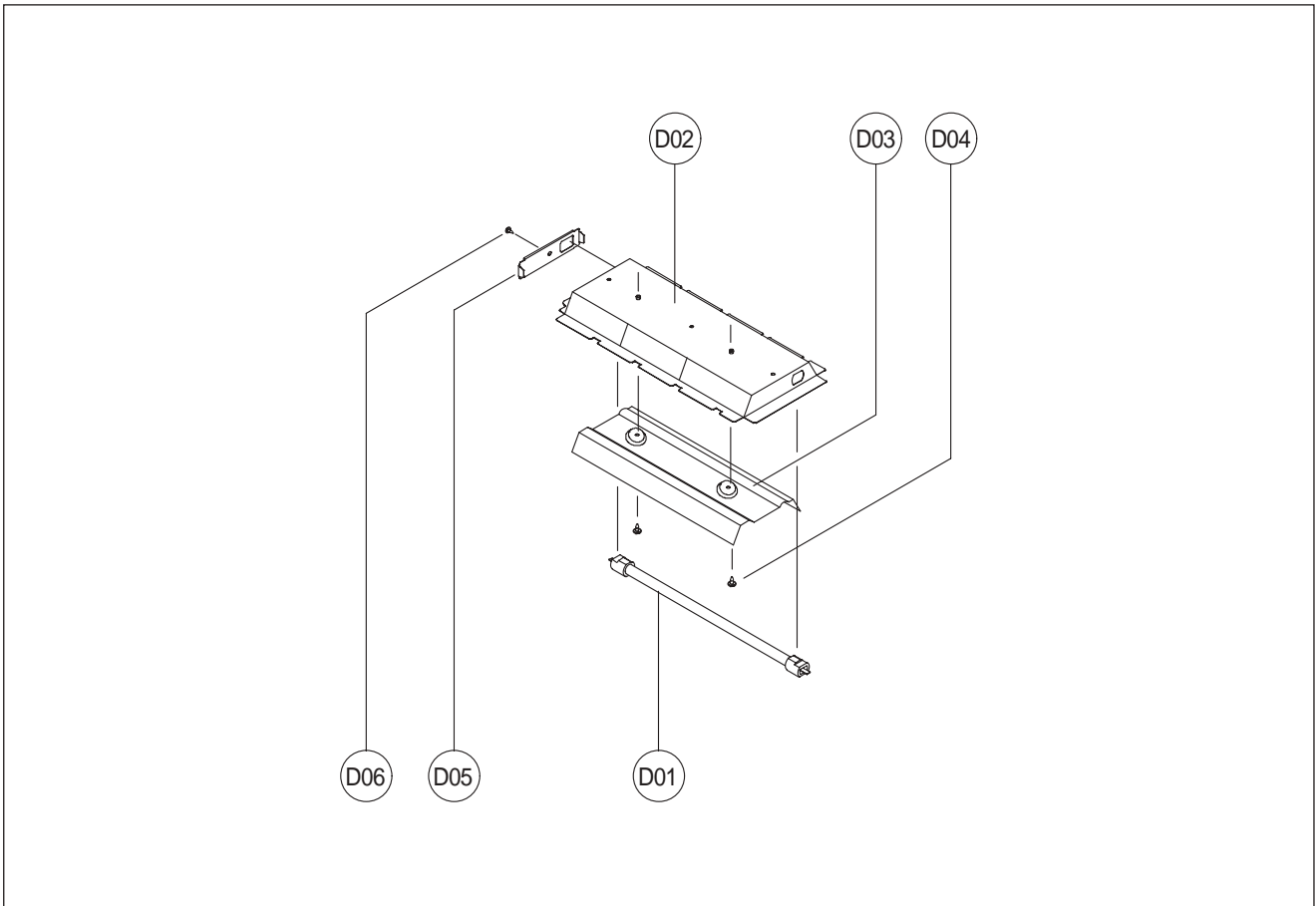

REF. NO	PART CODE	PART NAME	DESCRIPTION	Q'TY
H44	3512807530	HEATER *T AS	KOC-9Q0T7S	1
D01	3512805800	HEATER MIRACLON	230V 800W 270MM	1
D02	3511414500	COVER HEATER *T	SA1D T0.5	1
D03	3512808200	HEATER REFLECTOR	STS430 T0.4	1
D04	7123400808	SCREW TAPPING	T2S BIN 4X8 STS	2
D05	3510611300	BRACKET COVER HEATER	SBHG T0.5	1
D06	7123400808	SCREW TAPPING	T2S BIN 4X8 STS	1

- (1) Remove a screw from the BRACKET COVER HEATER.
- (2) Remove the BRACKET COVER HEATER from the COVER HEATER *T.
- (3) Remove the HEATER MIRACLON.
- (4) Remove two screws from the HEATER REFLECTOR.
- (5) Remove the HEATER REFLECTOR from the COVER HEATER *T.
- (6) Reverse the above steps for reassembly.

✓ **Caution** : In this Manual, some parts can be changed for improving, their performance without notice in the parts list. So, if you need the latest parts information, please refer to PPL(Parts Price List) in Service Information Center (<http://svc.dwe.co.kr>).

12. To remove guide air assembly parts.

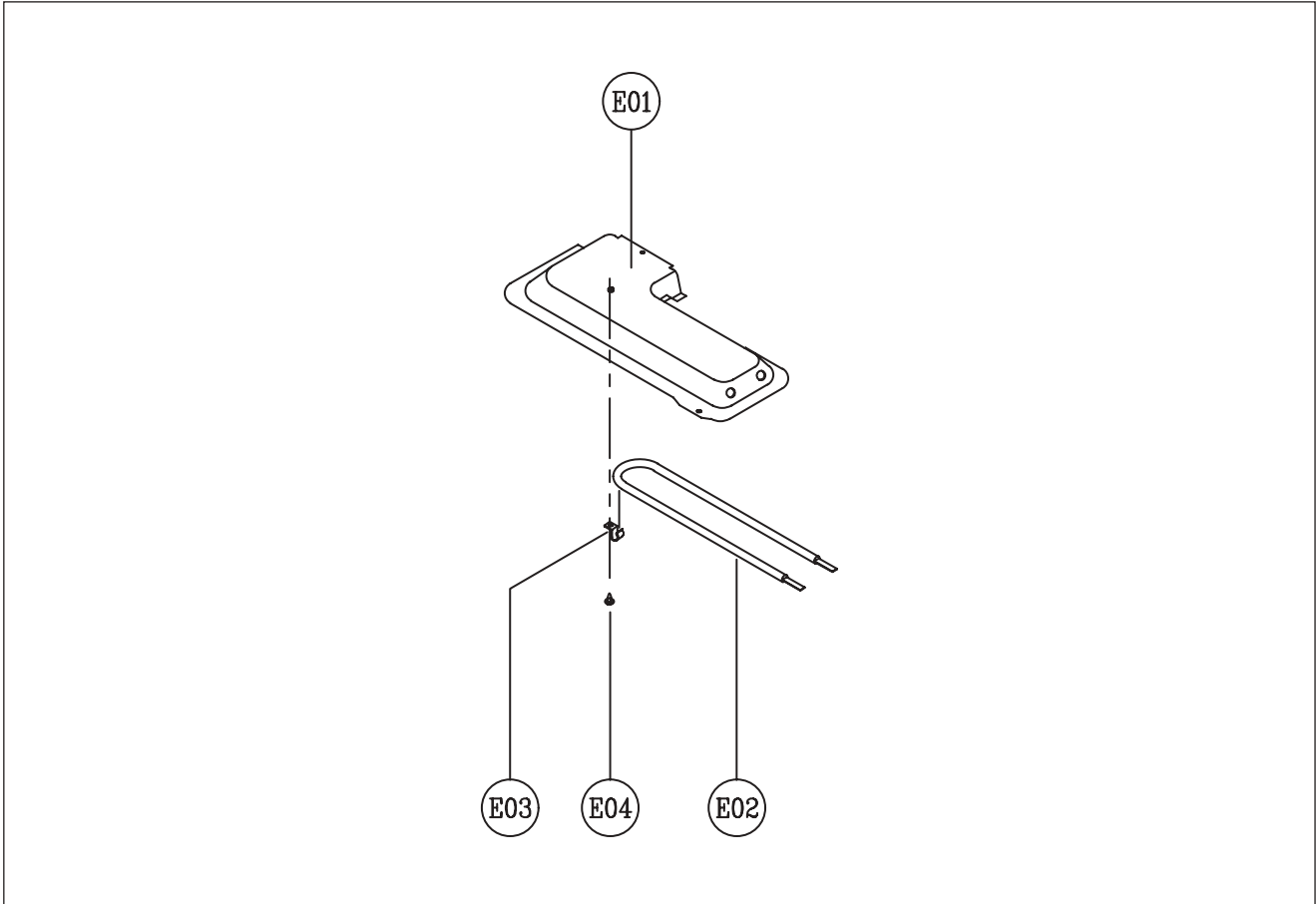

REF. NO	PART CODE	PART NAME	DESCRIPTION	Q'TY
H45	3512525510	GUIDE AIR AS	KOC-9Q0T7S	1
E01	3512528410	GUIDE AIR	SAID T0.5	1
E02	3512806700	HEATER *U	230V 400W TC	1
E03	3513004400	HOLDER HEATER	STS 301 T0.5	1
E04	7123400808	SCREW TAPPING	T2S BIN 4X8 STS	1

- (1) Remove a screw from the GUIDE AIR.
- (2) Remove the HOLDER HEATER from the GUIDE AIR.
- (3) Remove the HEATER *U.
- (4) Reverse the above steps for reassembly.

7. INTERLOCK MECHANISM AND ADJUSTMENT

The door lock mechanism is a device which has been specially designed to completely eliminate microwave radiation when the door is opened during operation, and thus to perfectly prevent the danger resulting from the leakage of microwave.

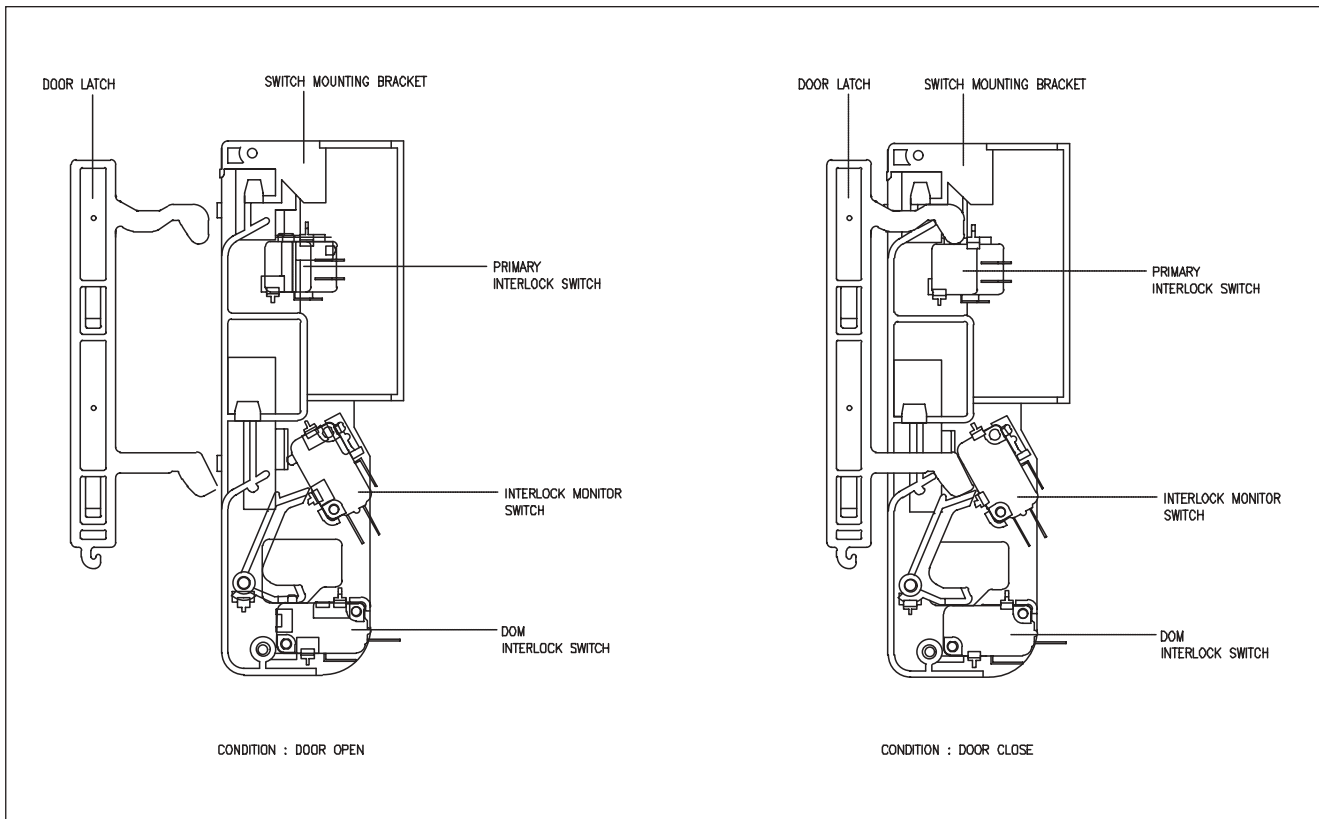

(1) Primary interlock switch

When the door is closed, the hook locks the oven door. If the door is not closed properly, the oven will not operate.

When the door is closed, the hook pushes the button of the microswitch. Then the button of the primary interlock switch bring it under ON condition. (NO position)

(2) DOM switch and interlock monitor switch

When the door is closed, the hook pushes the lock lever downward. The hook presses the button of the interlock monitor switch to bring it under OFF condition (NO position) and the lock lever presses the button of the DOM switch to bring it under ON condition. (NO position)

ADJUSTMENT :

Interlock monitor switch

When the door is closed, the interlock monitor switch should be opened (NO position) before other switches are closed.
When the door is opened, the interlock monitor switch should be closed (NC position) after other switches are opened.

(3) Adjustment steps

- Loosen the one mounting screw.
- Adjust interlock switch assembly position.
- Make sure that lock lever moves smoothly after adjustment is completed.
- Tighten completely two mounting screws.

NOTE :

Microwave emission test should be performed after adjusting interlock mechanism.
If the microwave emission exceed $4\text{mW}/\text{cm}^2$, readjust interlock mechanism.

8. TROUBLESHOOTING GUIDE

Following the procedure below to check if the oven is defective or not.

- 1) Check grounding before trouble checking.
- 2) Be careful of the high voltage circuit.
- 3) Discharge the high voltage capacitor.
- 4) When checking the continuity of the switches, fuse or high voltage transformer, disconnect one load wire from these parts and check continuity with the AC plug removed. To do otherwise may result in a false reading or damage to your meter.

NOTE : When electric parts are checked, be sure the power cord is not inserted the wall outlet.
Check wire harness, wiring and connection of the terminals and power cord before check the parts listed below.

(TROUBLE 1) Oven does not operate at all : any inputs can not be accepted.

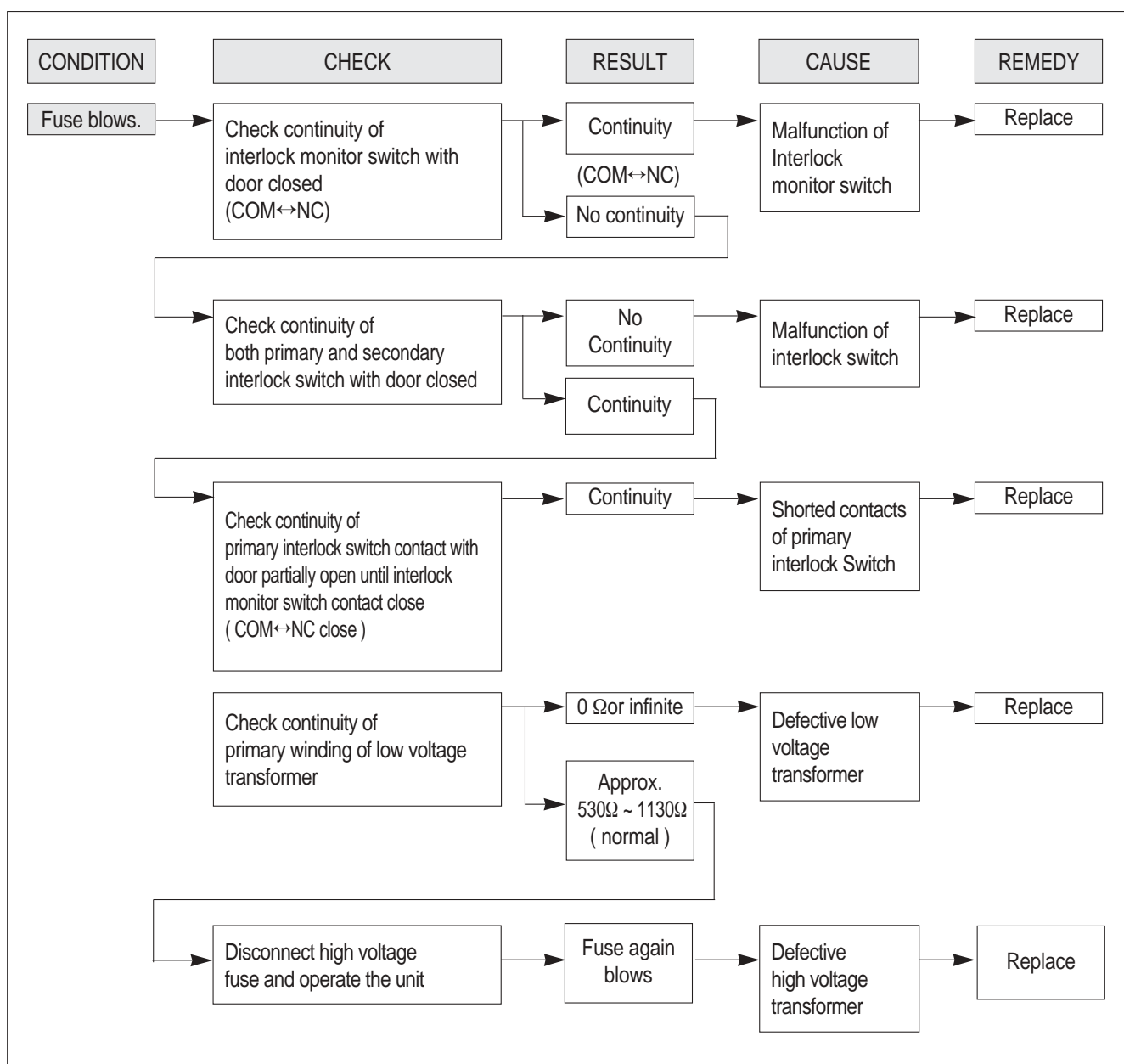

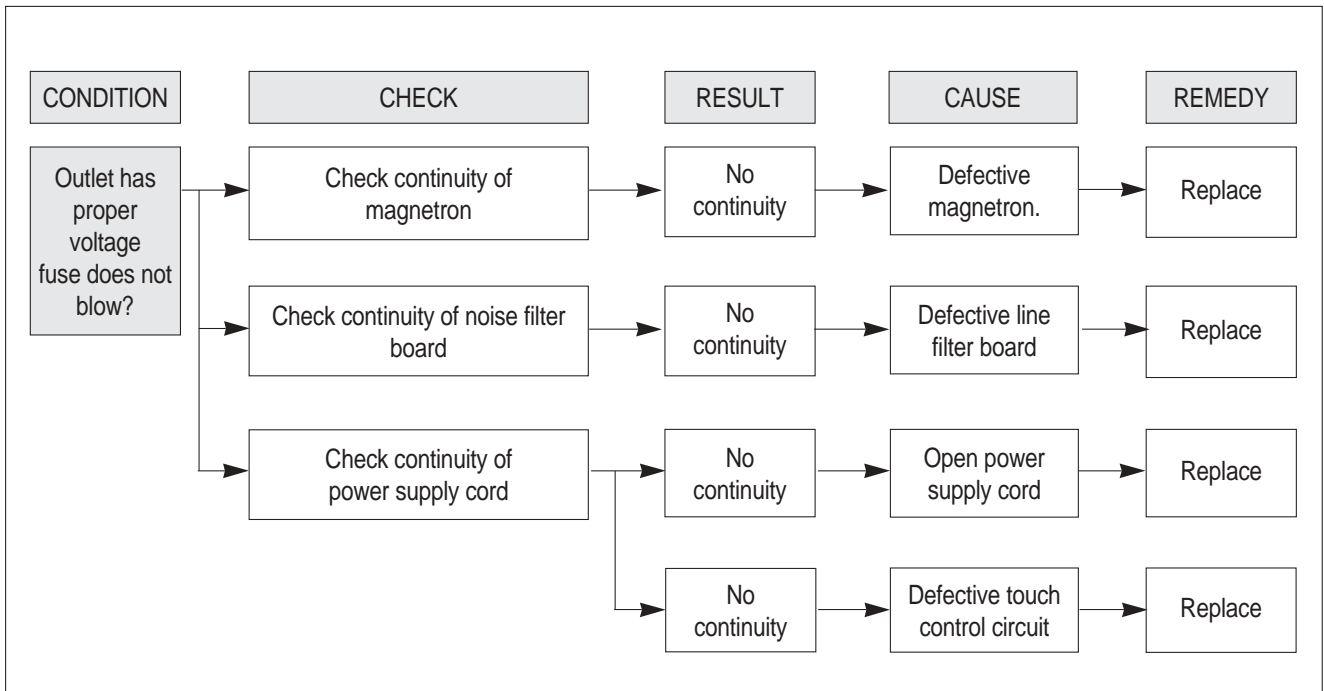

NOTE : All these switches must be replaced at the same time, please refer to (7.Interlock mechanism and adjust) for adjustment instructions

(TROUBLE 2)

Display shows all figures selected, but oven does not start cooking, even though desired program and time are set and start button is tapped.

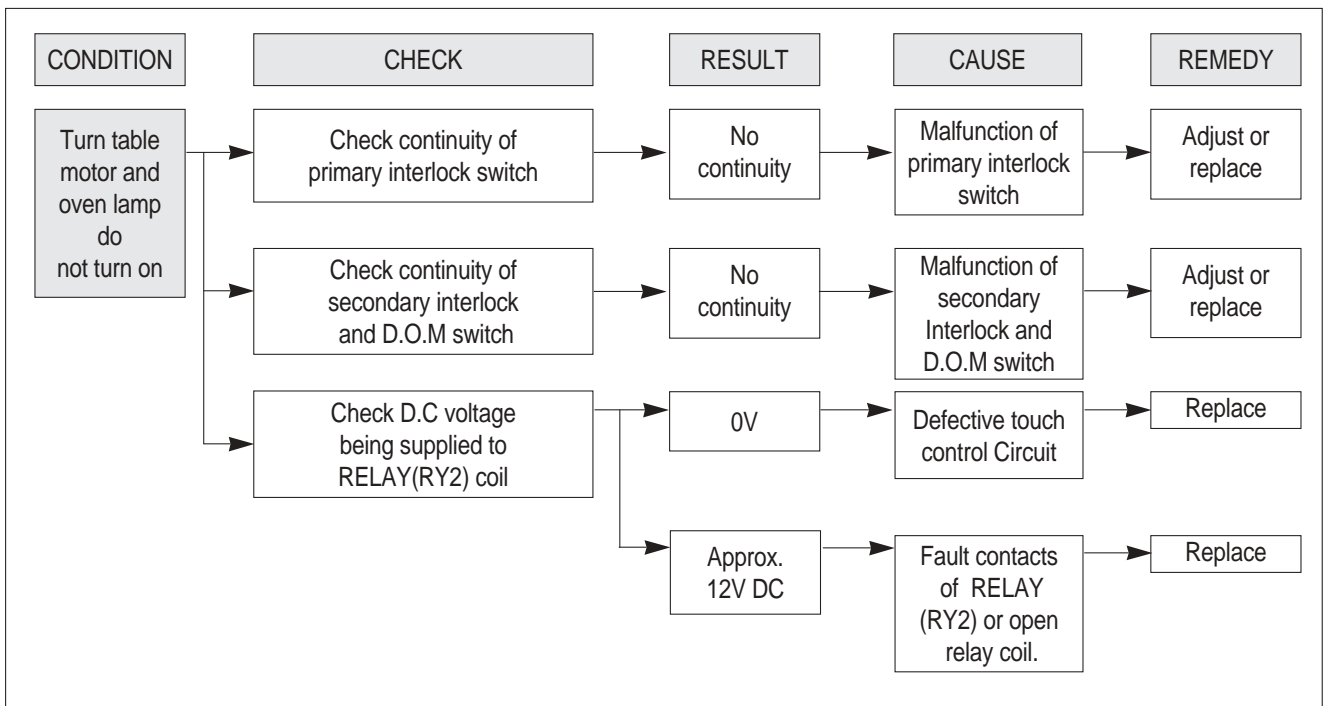

TROUBLE 3) No microwave oscillation even though fan motor rotates.

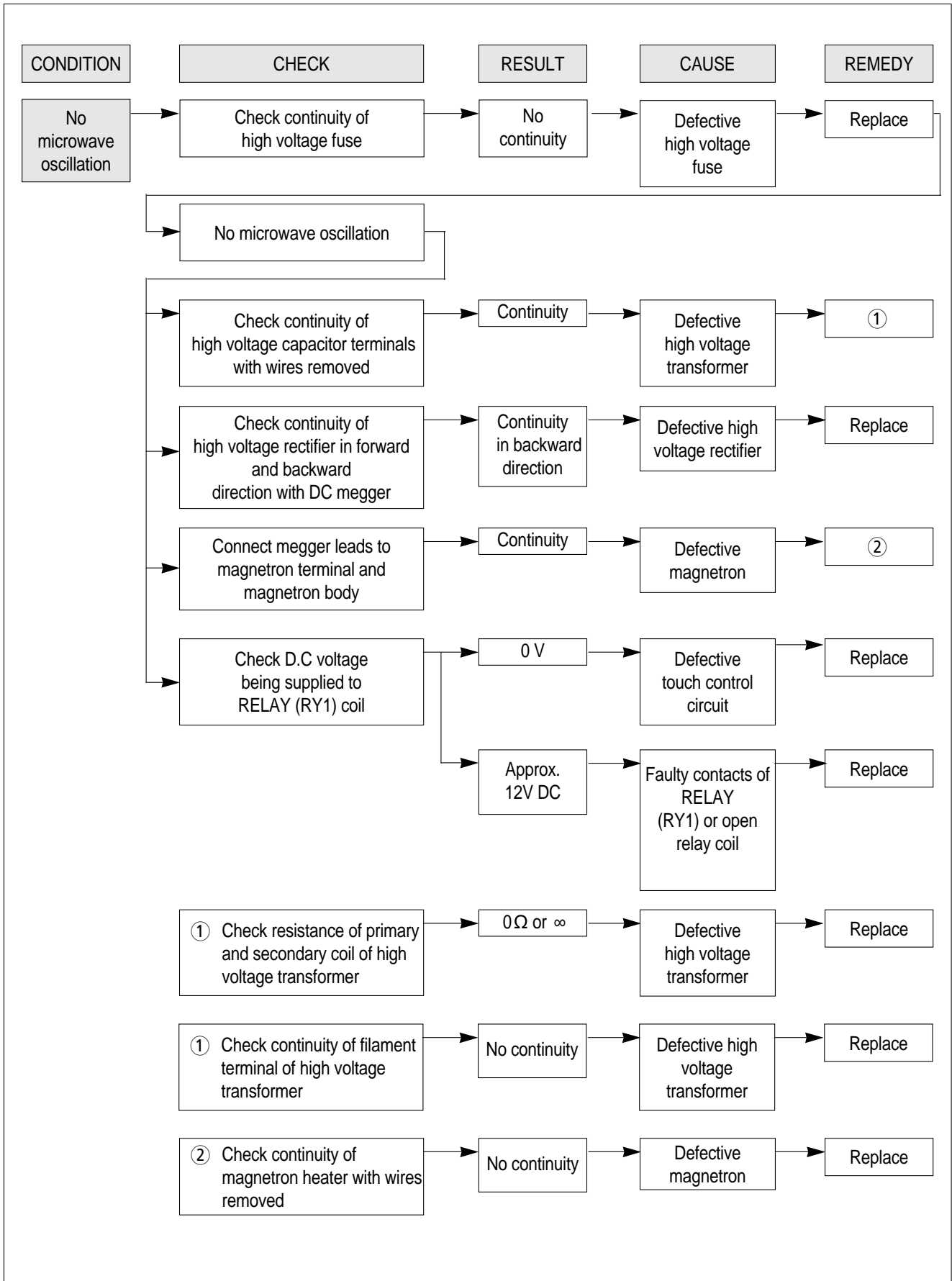

(TROUBLE 4)

Grill heater (upper heater) is not heated; food will not become hot.

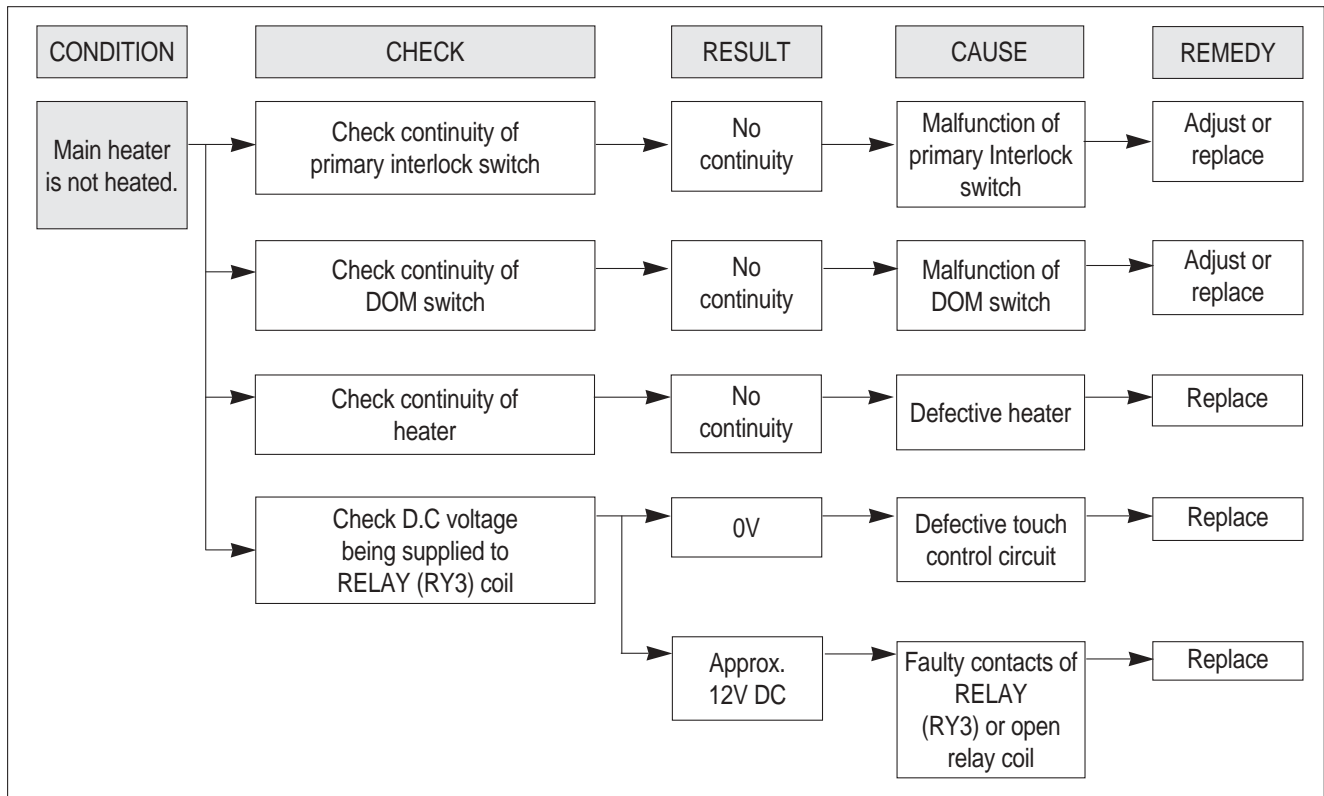

(TROUBLE 5)

1) Convection heater is not heated; food will not become hot.

2) Convection fan motor does not rotate.

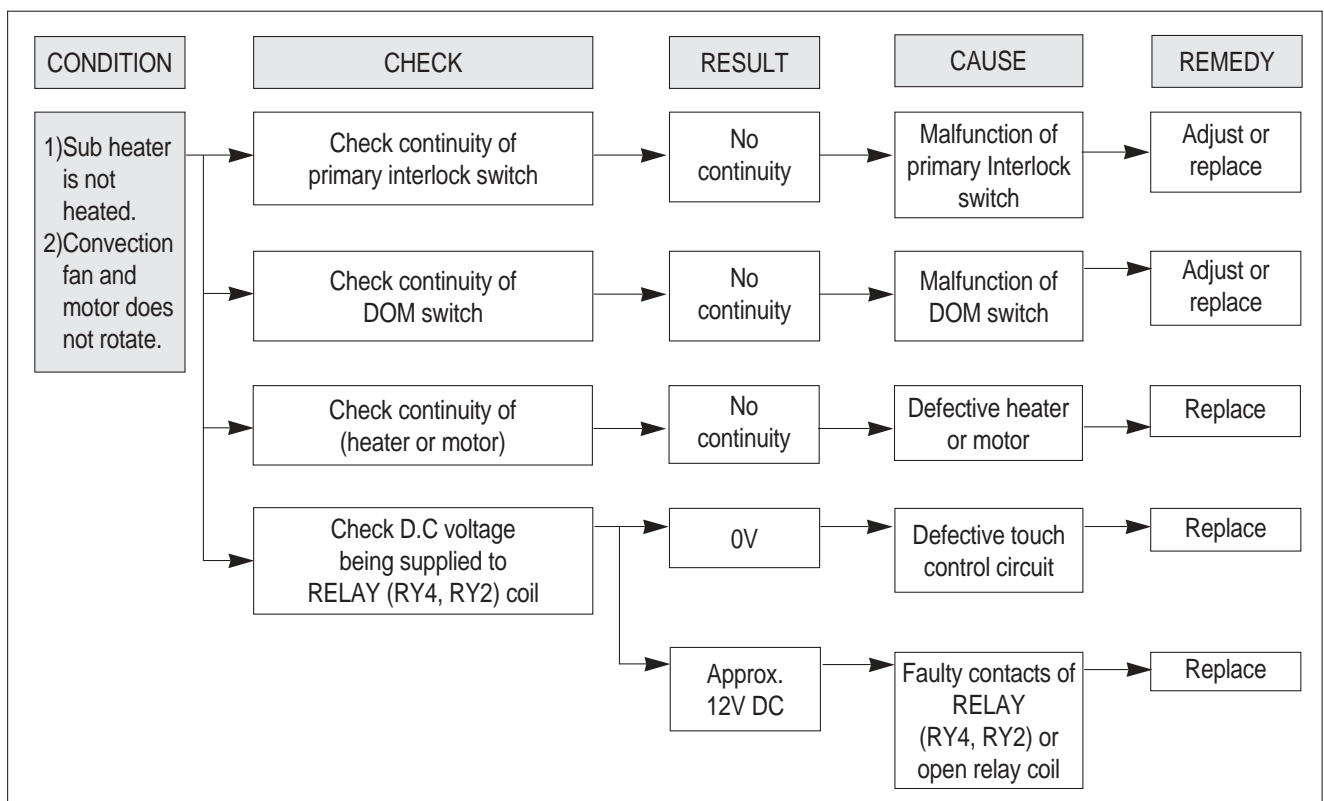

(TROUBLE 6)

The following visual conditions indicate a probable defective touch control Circuit or button P.C.B. assembly

1. Incomplete segments.
 - 1) segment missing
 - 2) partial segments missing
 - 3) digit flickering other than normal fluorescent slight flickering
2. A distinct change in the brightness of one or more numbers exists in the display.
3. One or more digits in the display are not on when they should be.
4. Display does not count down or up with time cooking or clock operation.
5. Oven is programmable and cooks normally but no display shows.
6. Display obviously jumps in time while counting down.
7. Display counts down noticeably too fast while cooking.
8. Display does not show the time of day when clear button is touched.
9. Oven lamp and turn table motor do not stop although cooking is finished.

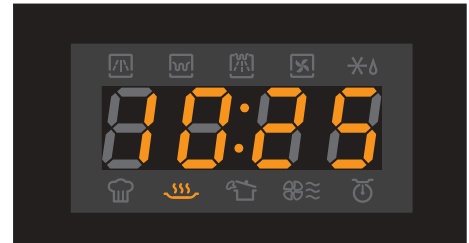

Check if the RELAY(RY2) contacts close and if they are close, replace touch control circuit.

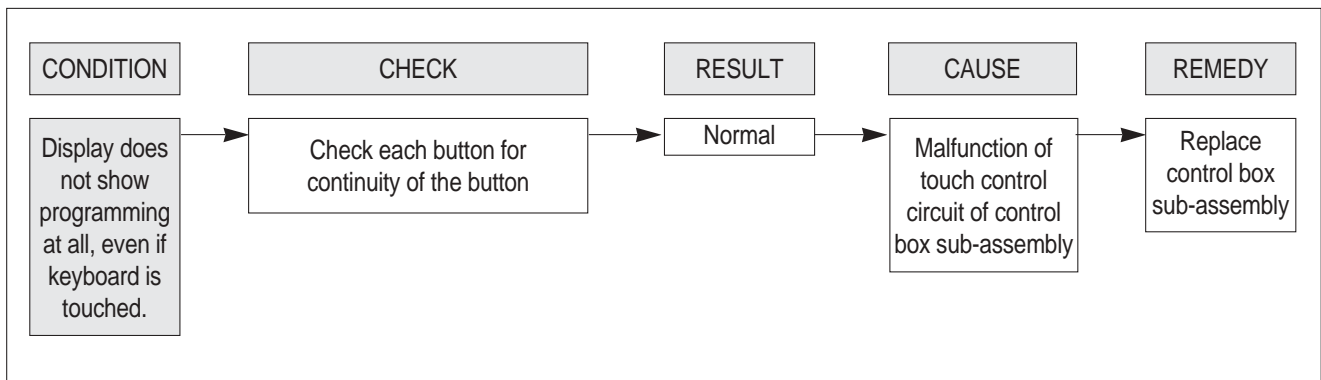

(TROUBLE 7)

When "ERROR 2 ERROR 3" come on display.

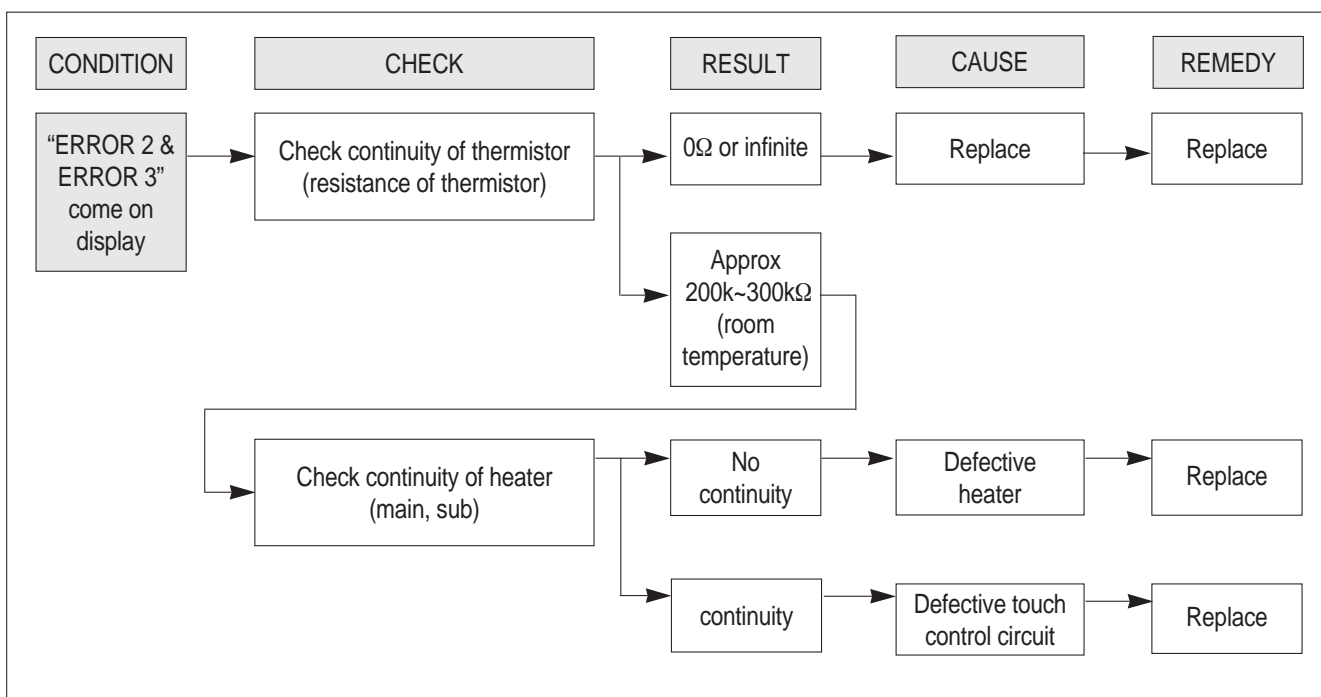

9. MEASUREMENT AND TEST

1. MEASUREMENT OF THE MICROWAVE POWER OUTPUT

Microwave output power can be checked by indirectly measuring the temperature rise of a certain amount of water exposed to the microwave as directed below.

PROCEDURE

1. A cylindrical container of borosilicate glass is used for the test. It has a maximum thickness of 3mm, an external diameter of approximately 190mm and a height of approximately 90mm. The mass of the container is determined.
2. At the start of the test, the oven and the empty container are at ambient temperature. Water having an initial temperature of $10^{\circ}\text{C} \pm 1^{\circ}\text{C}$ is used for the test. The water temperature is measured immediately before it is poured into the container.
3. A quantity of $1000\text{g} \pm 5\text{g}$ of water is added to the container and its actual mass obtained. The container is then immediately placed in the centre of the oven shelf, which is in its lowest normal position. The oven is operated and the time for the water temperature to attain $20^{\circ}\text{C} \pm 2^{\circ}\text{C}$ is measured. The oven is then switched off and the final water temperature is measured within 60s.

NOTE 1 - The water stirred is before its temperature is measured.

NOTE 2 - Stirring and measuring devices are to have a low heat capacity.

4. The microwave power output is calculated from the formula

$$P = 4,187 \cdot m_w(T_2 - T_1) + 0.55 \cdot m_c(T_2 - T_0)/t$$

where

- P is the microwave power output, in watts ;
- m_w is the mass of the water, in grams ;
- m_c is the mass of the container, in grams ;
- T_0 is ambient temperature, in degrees Celsius ;
- T_1 is the initial temperature of the water, in degree Celsius ;
- T_2 is the final temperature of the water, in degrees Celsius ;
- t is the heating time, in seconds, excluding the magnetron filament heating-up time.

* The microwave power output is stated in watts, rounded off to the nearest 50W

CAUTION

1. Water load should be measured exactly to 1 liter.
2. Input power voltage should be exactly specified voltage (Refer to 2. SPECIFICATIONS).
3. Ambient temperature should be $20 \pm 2^{\circ}\text{C}$ ($68 \pm 3.6^{\circ}\text{F}$)

* Heating time for power output: ($T_2 = T_0$)

A (second)	70	64	60	56	52	49	47	44	42	40	38
B (W)	600	650	700	750	800	850	900	950	1000	1050	1100

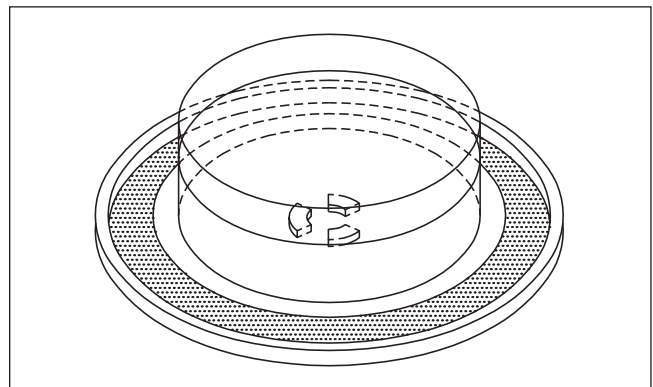

2. MICROWAVE RADIATION TEST

WARNING

1. Make sure to check the microwave leakage before and after repair of adjustment.
2. Always start measuring of an unknown field to assure safety for operating personnel from microwave energy.
3. Do not place your hands into any suspected microwave radiation field unless the safe density level is known.
4. Care should be taken not to place the eyes in direct line with the source of microwave energy.
5. Slowly approach the unit under test until the radiometer reads an appreciable microwave leakage from the unit under the test.

PROCEDURE

1. Prepare Microwave Energy Survey Meter, 600cc glass beaker, and glass thermometer 100°C (212°F).
2. Pour 275cc ± 15cc of tap water initially at 20 ± 5°C (68 ± 9°F) in the 600 cc glass beaker with an inside diameter of approx. 95 mm(3.5 in.).
3. Place it at the center of the tray and set it in a cavity.
4. Close the door and operate the oven.
5. Measure the leakage by using Microwave Energy Survey Meter with dual ranges, set to 2450MHz.
 - 1) Measured radiation leakage must not exceed the value prescribed below. Leakage for a fully assembled oven with door normally closed must be less than 4mW/Cm².
 - 2) When measuring the leakage, always use the 5 cm (2 in.) space cone with probe. Hold the probe perpendicular to the cabinet and door. Place the space cone of the probe on the door, cabinet, door seem, door viewing screen, the exhaust air vents and the suction air vents.
 - 3) Measuring should be in a counter-clockwise direction at a rate of 1 in./sec. If the leakage of the cabinet door seem is unknown, move the probe more slowly.
 - 4) When measuring near a corner of the door, keep the probe perpendicular to the areas making sure the probe end at the base of the cone does not get closer than 2 in. from any metal. If it does not, erroneous reading may result.

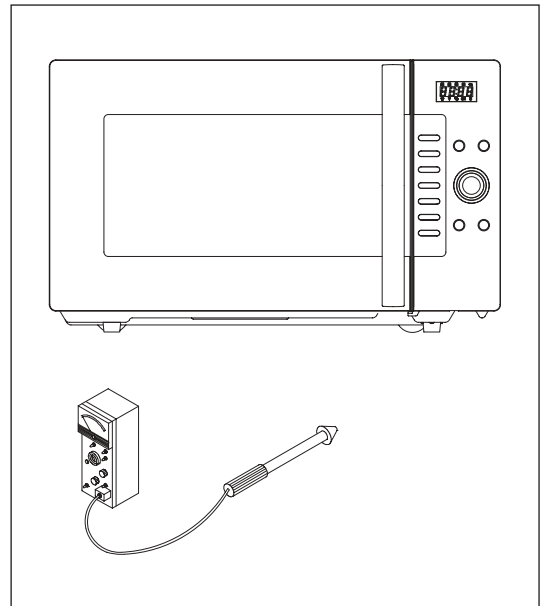

3. COMPONENT TEST PROCEDURE

- High voltage is present at the high voltage terminal of the high voltage transformer during any cooking cycle.
- It is neither necessary nor advisable to attempt measurement of the high voltage.
- Before touching any oven components or wiring, always unplug the oven from its power source and discharge the capacitor.

1. High voltage transformer

- 1) Remove connections from the transformer terminals and check continuity.
- 2) Normal readings should be as follows :
 - Secondary winding ... Approx. $168 \Omega \pm 10\%$
 - Filament winding ... Approx. 0Ω
 - Primary winding ... Approx. 1.97Ω

2. High voltage capacitor

- 1) Check continuity of capacitor with meter on the highest OHM scale.
- 2) A normal capacitor will show continuity for a short time, and then indicate 10MW once the capacitor charged.
- 3) A shorted capacitor will show continuous continuity.
- 4) An open capacitor will show constant 10M Ω
- 5) Resistance between each terminal and chassis should be infinite.

3. High voltage diode

- 1) Isolate the diode from the circuit by disconnecting the leads.
- 2) With the ohmmeter set on the highest resistance scale measure the resistance across the diode terminals. Reverse the meter leads and again observe the resistance reading. Meter with 6V, 9V or higher voltage batteries should be used to check the front-back resistance of the diode, otherwise an infinite resistance may be read in both directions. A normal diode's resistance will be infinite in one direction and several hundred k Ω in the other direction.

4. Magnetron

For complete magnetron diagnosis, refer to "Measurement of the Microwave Output Power." Continuity checks can only indicate an open filament or a shorted magnetron. To diagnose for an open filament or a shorted magnetron,

- 1) Isolate magnetron from the circuit by disconnecting the leads.
- 2) A continuity check across magnetron filament terminals should indicate 0.1Ω or less.
- 3) A continuity check between each filament terminal and magnetron case should read open.

5. Fuse

If the fuse in the primary and monitor switch circuit is blown when the door is opened, check the primary and monitor switch before replacing the blown fuse. In case the fuse is blown by an improper switch operation, replace the defective switch and fuse at the same time. Replace just the fuse if the switches operate normally.

4. COMPONENT ACTION

COOKING MODE		MAGNE-TRON	MAIN HEATER	SUB HEATER	CONVEC-TION FAN
MANUAL MODE	M/W	●			●
	GRILL		●	●	●
	COMBI	●	●	●	●
	CONVECTION		●	●	●
AUTO MODE	ROAST PORK	●	●	●	●
	ROAST BEEF	●	●	●	●
	ROAST CHICKEN	●	●	●	●
	BAKED FISH	●	●	●	●
	FRESH VEGETABLES	●			●
DEFROST		●			●
STEAM CLEANING		●		●	●
WARM				●	●

10. WIRING DIAGRAM

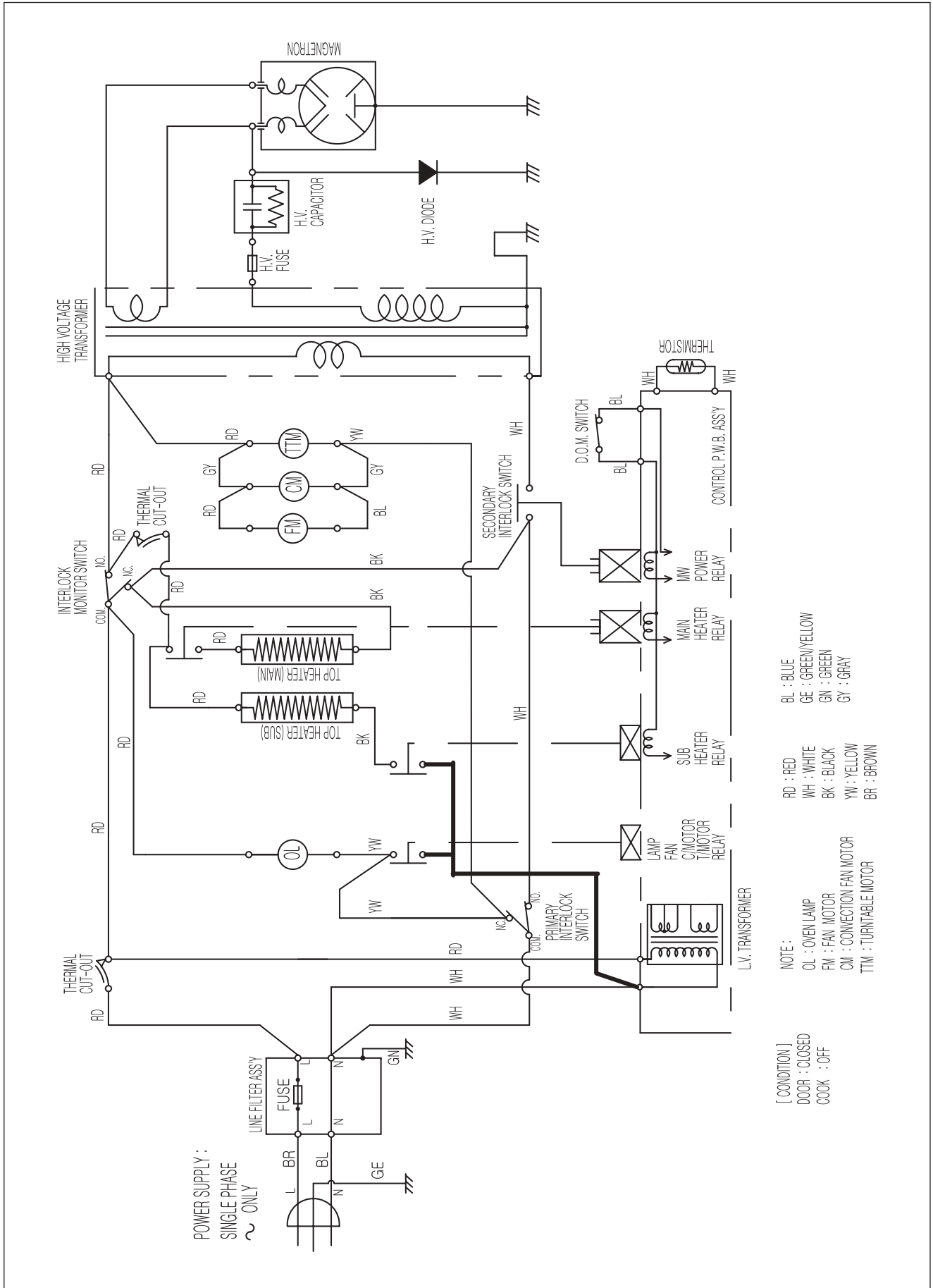

11. EXPLODED VIEW AND PARTS LIST

1. DOOR ASSEMBLY

Refer to 6. Disassembly and assembly.

2. CONTROL PANEL ASSEMBLY

Refer to 6. Disassembly and assembly.

3. TOTAL ASSEMBLY

1) KOC-9Q3T7S

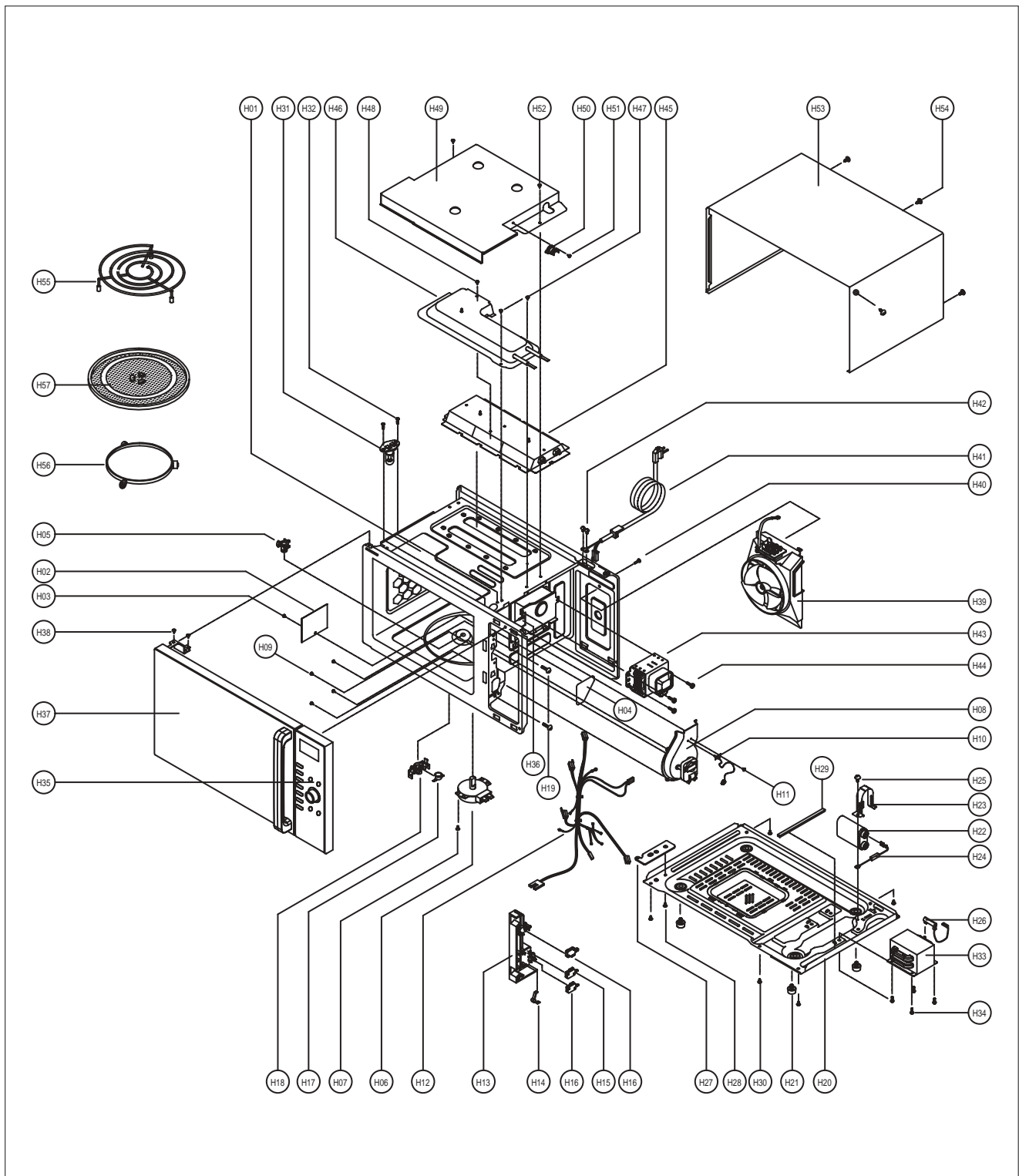

✓ **Caution** : In this Manual, some parts can be changed for improving, their performance without notice in the parts list. So, if you need the latest parts information, please refer to PPL(Parts Price List) in Service Information Center (<http://svc.dwe.co.kr>).

REF. NO	PART CODE	PART NAME	DESCRIPTION	Q'TY
H01	3516119900	CAVITY AS	KOC-9Q0T7S	1
H02	3511403800	COVER WAVE GUIDE	MICA T0.35	1
H03	7113400810	SCREW TAPPING	T1 BIN 4X8 STS430 MFZN	1
H04	3511414800	COVER LAMP	PE 0.1T	1
H05	3517413410	COUPLER	TEFLON	1
H06	3966031800	MOTOR SYNCRO	49TYD -5C	1
H07	7122400611	SCREW TAPPING	T2S TRS 4X6 MFZN	1
H08	3511801400	FAN CONVECTION AS	KOC-9Q0T7S	1
H09	7113400810	SCREW TAPPING	T1 BIN 4X8 STS430 MFZN	4
H10	3514801400	SENSOR TEMPERATURE	PTM-K312-D7	1
H11	7S432X4081	SPECIAL SCREW	TT3 TRS 4X8 SE MFZN	1
H12	3512783520	HARNESS MAIN	KOC-9Q0T7S	1
H13	3513820520	LOCK	PP	1
H14	3513702630	LEVER LOCK	POM	1
H15	4415A17352	SW MICRO	VP-533A-OF SPNO #187 200G	1
H16	4415A66910	SW MICRO	VP-531A-OF/SZM-V16-FA-61	2
H17	3518907020	THERMOSTAT	OFF:120 ON:60 H #187 NB	1
H18	3513003410	HOLDER THERMOSTAT	PP(BK)	1
H19	7122401211	SCREW TAPPING	T2S TRS 4X12 MFZN	2
H20	3510317520	BASE	SBHG T0.5	1
H21	3512101400	FOOT	DASF-310	2
H22	3518303100	CAPACITOR HV	2100VAC 0.98UF #187 +3 -0	1
H23	3513003200	HOLDER HV CAPACITOR	SECC T0.5	1
H24	3518400400	DIODE HV	HVR-1X-3AB 12KV #187	1
H25	7S432X4081	SPECIAL SCREW	TT3 TRS 4X8 SE MFZN	1
H26	3518702100	FUSE HV	5KV 0.7A T.H.V.060T	1
H27	3515201101	STOPPER HINGE *U	SCP-1 T2.5	1
H28	7272400811	SCREW TAPTITE	TT3 TRS 4X8 MFZN	1
H29	3517304300	FOAM	CR 15TX150X15	1
H30	7S312X40A1	SCREW SPECIAL	T1 TRS 4X10 SE MFZN	6
H31	3513601600	LAMP	BL 240V 25W T25 C7A H187	1
H32	4414H50000	FIXTURE AS	KOG-36150S	2
H33	3518124400	TRANS HV	R1S59E ES00	1
H34	3516003700	SPECIAL SCREW	TT3 HEX 4X8 FLG MFZN	4
H35	3516738710	CONTROL-PANEL AS	KOC-9Q3T7S	1
H36	7122401211	SCREW TAPPING	T2S TRS 4X12 MFZN	1
H37	3511728340	DOOR AS	KOC-9Q3T7S	1
H38	7272400811	SCREW TAPTITE	TT3 TRS 4X8 MFZN	2

✓ **Caution** : In this Manual, some parts can be changed for improving, their performance without notice in the parts list.
 So, if you need the latest parts information, please refer to PPL(Parts Price List) in Service Information Center
 (<http://svc.dwe.co.kr>).

REF. NO	PART CODE	PART NAME	DESCRIPTION	Q'TY
H39	3512529400	GUIDE WIND AS	KOC-9Q0T7S	1
H40	7122401211	SCREW TAPPING	T2S TRS 4X12 MFZN	1
H41	35113A5QJ5	CORD POWER AS	3X1.5 80X80 120-RTML 1.4M	1
H42	7S312X40A1	SCREW SPECIAL	T1 TRS 4X10 SE MFZN	2
H43	3518003700	MAGNETRON	2M218JFL 6CF	1
H44	3516003700	SPECIAL SCREW	TT3 HEX 4X8 FLG MFZN	3
H45	3512807530	HEATER *T AS	KOC-9Q0T7S	1
H46	3512525510	GUIDE AIR AS	KOC-9Q0T7S	1
H47	7112401011	SCREW TAPPING	T1 TRS 4*10 MFZN	2
H48	7113400810	SCREW TAPPING	T1 BIN 4X8 STS430 MFZN	1
H49	3513304400	INSULATOR HEATER *T	SBHG T0.4	1
H50	3518903800	THERMOSTAT	OFF:160 ON:115 V #187	1
H51	7121400611	SCREW TAPPING	T2S PAN 4X6 MFZN	1
H52	7S312X40A1	SCREW SPECIAL	T1 TRS 4X10 SE MFZN	2
H53	3510810800	CABINET AS	KOC-9Q0T7S	1
H54	7S312X40A1	SCREW SPECIAL	T1 TRS 4X10 SE MFZN	5
H55	3517212000	TRAY RACK AS	KOC-9Q0T7S 35MM	1
H56	3512512930	GUIDE ROLLER AS	KOR-121Q3A XAREC	1
H57	441CD35011	TRAY	GLASS DIA:325 1320G	1

1. DOOR ASSEMBLY

Refer to 6. Disassembly and assembly.

2. CONTROL PANEL ASSEMBLY

Refer to 6. Disassembly and assembly.

3. TOTAL ASSEMBLY

2) KOC-9Q4T7S / 9Q4T7WA9

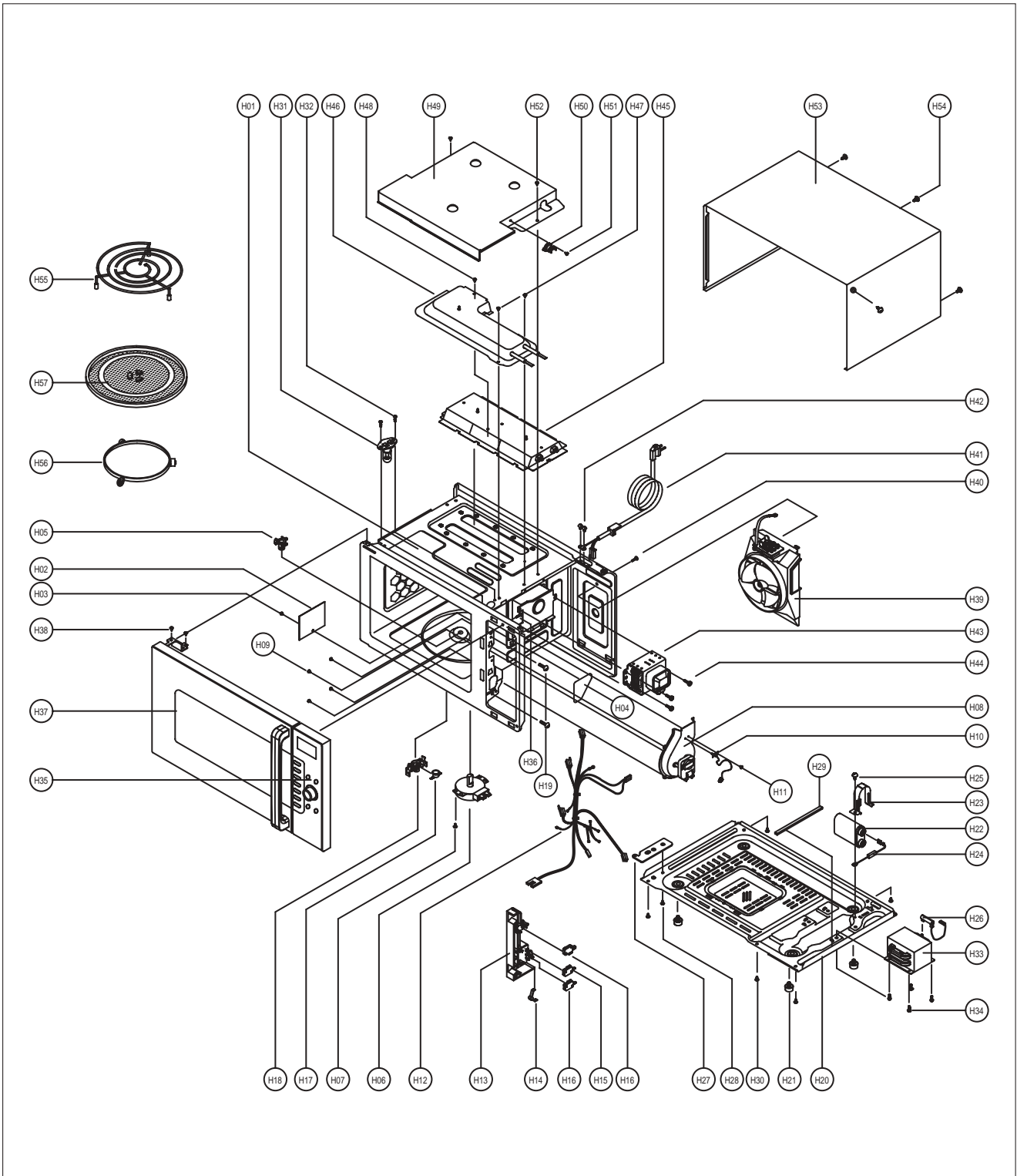

✓ **Caution** : In this Manual, some parts can be changed for improving, their performance without notice in the parts list. So, if you need the latest parts information, please refer to PPL(Parts Price List) in Service Information Center (<http://svc.dwe.co.kr>).

REF. NO	PART CODE	PART NAME	DESCRIPTION	Q'TY
H01	3516119900	CAVITY AS	KOC-9Q0T7S	1
H02	3511403800	COVER WAVE GUIDE	MICA T0.35	1
H03	7113400810	SCREW TAPPING	T1 BIN 4X8 STS430 MFZN	1
H04	3511414800	COVER LAMP	PE 0.1T	1
H05	3517413410	COUPLER	TEFLON	1
H06	3966031800	MOTOR SYNCRO	49TYD -5C	1
H07	7122400611	SCREW TAPPING	T2S TRS 4X6 MFZN	1
H08	3511801400	FAN CONVECTION AS	KOC-9Q0T7S	1
H09	7113400810	SCREW TAPPING	T1 BIN 4X8 STS430 MFZN	4
H10	3514801400	SENSOR TEMPERATURE	PTM-K312-D7	1
H11	7S432X4081	SPECIAL SCREW	TT3 TRS 4X8 SE MFZN	1
H12	3512783520	HARNESS MAIN	KOC-9Q0T7S	1
H13	3513820520	LOCK	PP	1
H14	3513702630	LEVER LOCK	POM	1
H15	4415A17352	SW MICRO	VP-533A-OF SPNO #187 200G	1
H16	4415A66910	SW MICRO	VP-531A-OF/SZM-V16-FA-61	2
H17	3518907020	THERMOSTAT	OFF:120 ON:60 H #187 NB	1
H18	3513003410	HOLDER THERMOSTAT	PP(BK)	1
H19	7122401211	SCREW TAPPING	T2S TRS 4X12 MFZN	2
H20	3510317520	BASE	SBHG T0.5	1
H21	3512101400	FOOT	DASF-310	2
H22	3518303100	CAPACITOR HV	2100VAC 0.98UF #187 +3 -0	1
H23	3513003200	HOLDER HV CAPACITOR	SECC T0.5	1
H24	3518400400	DIODE HV	HVR-1X-3AB 12KV #187	1
H25	7S432X4081	SPECIAL SCREW	TT3 TRS 4X8 SE MFZN	1
H26	3518702100	FUSE HV	5KV 0.7A T.H.V.060T	1
H27	3515201101	STOPPER HINGE *U	SCP-1 T2.5	1
H28	7272400811	SCREW TAPTITE	TT3 TRS 4X8 MFZN	1
H29	3517304300	FOAM	CR 15TX150X15	1
H30	7S312X40A1	SCREW SPECIAL	T1 TRS 4X10 SE MFZN	6
H31	3513601600	LAMP	BL 240V 25W T25 C7A H187	1
H32	4414H50000	FIXTURE AS	KOG-36150S	2
H33	3518124400	TRANS HV	R1S59E ES00	1
H34	3516003700	SPECIAL SCREW	TT3 HEX 4X8 FLG MFZN	4
H35	3516738700	CONTROL-PANEL AS	KOC-9Q4T7S	1
	3516738780		KOC-9Q4T7WA9	1
H36	7122401211	SCREW TAPPING	T2S TRS 4X12 MFZN	1
H37	3511728330	DOOR AS	KOC-9Q4T7S	1
H38	7272400811	SCREW TAPTITE	TT3 TRS 4X8 MFZN	2

✓ **Caution** : In this Manual, some parts can be changed for improving, their performance without notice in the parts list.
 So, if you need the latest parts information, please refer to PPL(Parts Price List) in Service Information Center
 (<http://svc.dwe.co.kr>).

REF. NO	PART CODE	PART NAME	DESCRIPTION	Q'TY
H39	3512529400	GUIDE WIND AS	KOC-9Q0T7S	1
H40	7122401211	SCREW TAPPING	T2S TRS 4X12 MFZN	1
H41	35113A5QJ5	CORD POWER AS	3X1.5 80X80 120-RTML 1.4M	1
H42	7S312X40A1	SCREW SPECIAL	T1 TRS 4X10 SE MFZN	2
H43	3518003700	MAGNETRON	2M218JFL 6CF	1
H44	3516003700	SPECIAL SCREW	TT3 HEX 4X8 FLG MFZN	3
H45	3512807530	HEATER *T AS	KOC-9Q0T7S	1
H46	3512525510	GUIDE AIR AS	KOC-9Q0T7S	1
H47	7112401011	SCREW TAPPING	T1 TRS 4*10 MFZN	2
H48	7113400810	SCREW TAPPING	T1 BIN 4X8 STS430 MFZN	1
H49	3513304400	INSULATOR HEATER *T	SBHG T0.4	1
H50	3518903800	THERMOSTAT	OFF:160 ON:115 V #187	1
H51	7121400611	SCREW TAPPING	T2S PAN 4X6 MFZN	1
H52	7S312X40A1	SCREW SPECIAL	T1 TRS 4X10 SE MFZN	2
H53	3510810800	CABINET AS	KOC-9Q0T7S	1
H54	7S312X40A1	SCREW SPECIAL	T1 TRS 4X10 SE MFZN	5
H55	3517212000	TRAY RACK AS	KOC-9Q0T7S 35MM	1
H56	3512512930	GUIDE ROLLER AS	KOR-121Q3A XAREC	1
H57	441CD35011	TRAY	GLASS DIA:325 1320G	1

12. PRINTED CIRCUIT BOARD

CIRCUIT CHECK PROCEDURE

1. Low voltage transformer check

The low voltage transformer is located on the P.C.B.
 Measuring condition: Input voltage: 230V / Frequency: 50Hz

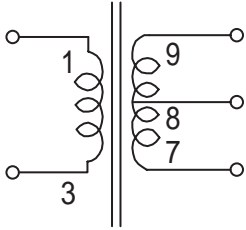

Terminal	Voltage(load)	Voltage(no load)
7-8-9	DC 13.5 V	AC 37 V

NOTE

1. Secondary side voltage of the low voltage transformer changes in proportion to fluctuation of power source voltage.
2. The allowable tolerance of the secondary voltage is within $\pm 5\%$ of nominal voltage.

2. Voltage Check

- Key check point

NO	CHECK POINT	REMARK
1	IC1 PIN 5, 34, 35	5VDC \pm 5%
2	IC1 PIN 10	<p>T : 20 ms(50Hz)</p>
3	IC1 PIN 2 OR 3	<p>T : 250 ns(4MHz)</p>

- Check method

NO	MEASURE POINT	WAVE FORM	REMEDY	REMARK
1	MP1	DC 5V \pm 5%	Replace VL1,EC1,C4,C5	NO LOAD
2	MP2	DC 12V \pm 20%	Replace D14,D15,EC2,R21,D12	NO LOAD

NOTE: Each measure point must be measured with GND points.

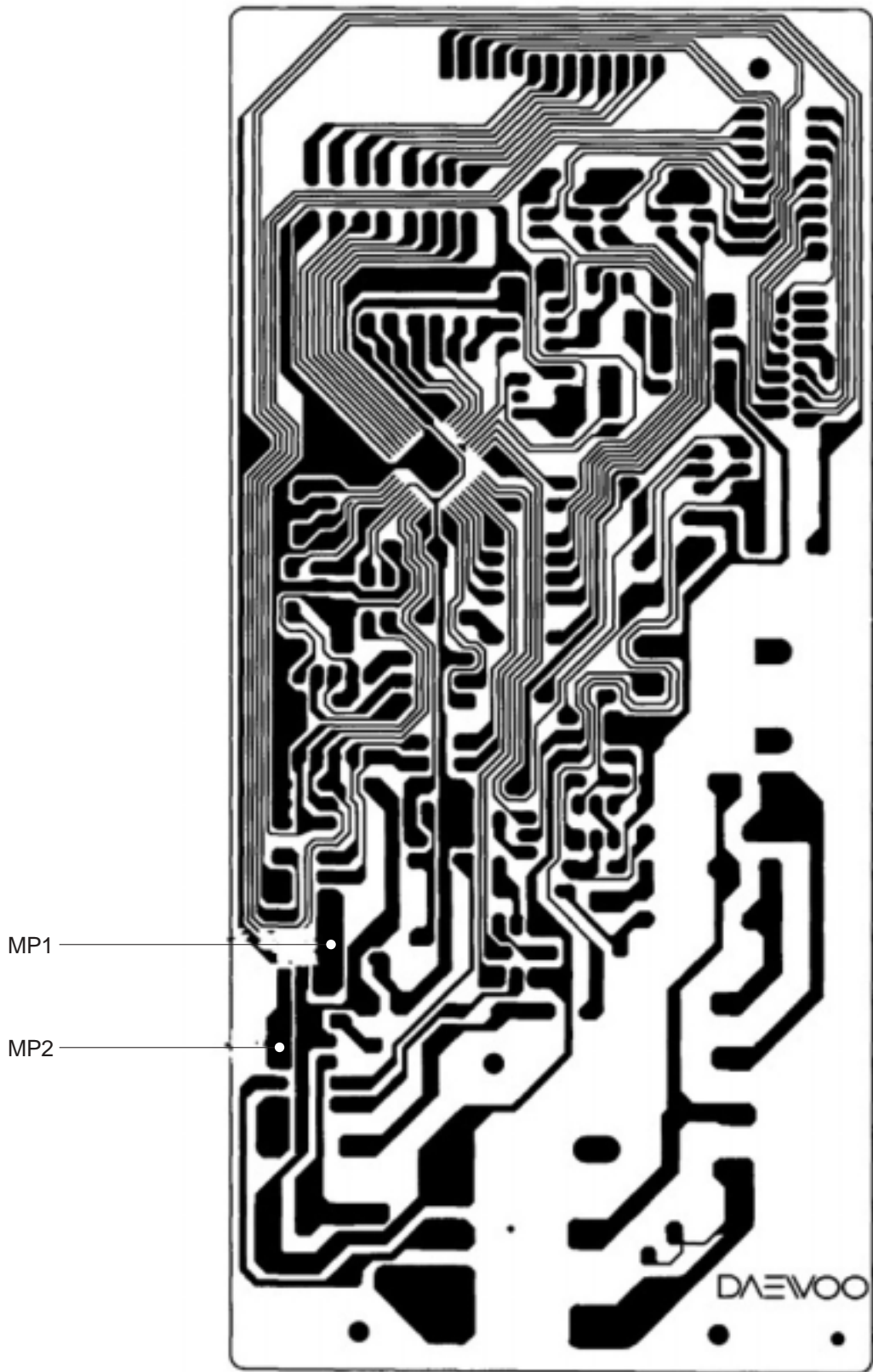

MEASUREPOINT

3. Case of no microwave oscillation

1) When touching M/W button, oven lamp turns on and Fan motor and turntable rotate, and cook indicator in display comes on.

*Cause: **RELAY 1** does not operate.

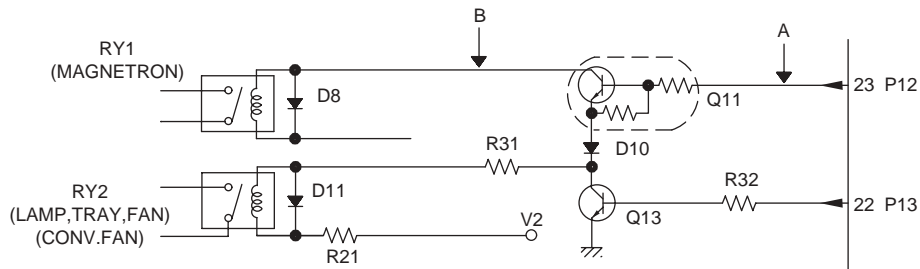

STATE	POINT A	POINT B
RELAY 1 ON	+5V DC	GND
RELAY 1 OFF	GND	12V DC

2) When touching M/W button, oven lamp does not turn on and turntable motor does not rotate but cook indicator in display comes on.

*Cause: **RELAY 2** does not operate.

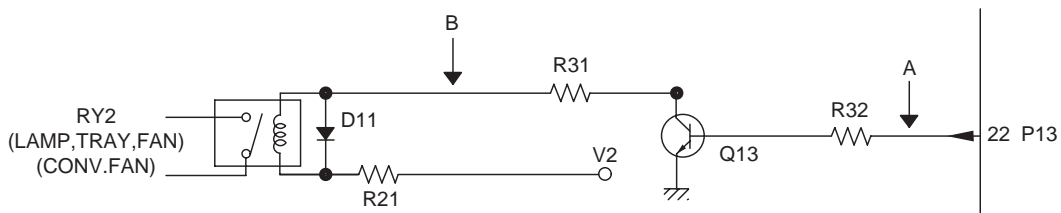

STATE	POINT A	POINT B
RELAY 2 ON	+5V DC	GND
RELAY 2 OFF	GND	12V DC

- Check method

3) When touching M/W button, oven lamp turns on and fan motor does not rotate but cook indicator in display comes on.

*Cause: **RELAY 2** does not operate.

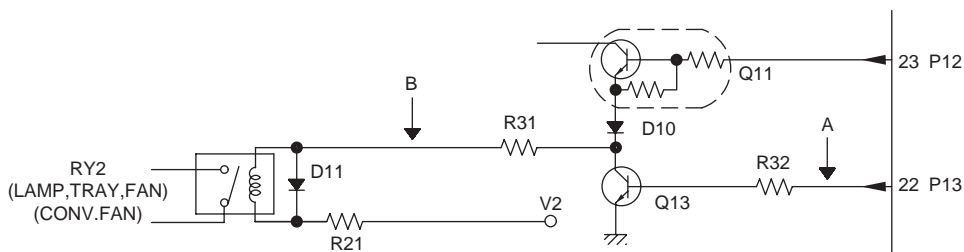

STATE	POINT A	POINT B
RELAY 2 ON	+5V DC	GND
RELAY 2 OFF	GND	12V DC

- Check method

4. Case of no heating of top heater main.

When touching GRILL or COMBI or CONVECTION button, oven lamp turns on and fan motor and turntable rotate, and cook indicator in display comes on.

*Cause: **RELAY 3** does not operate.

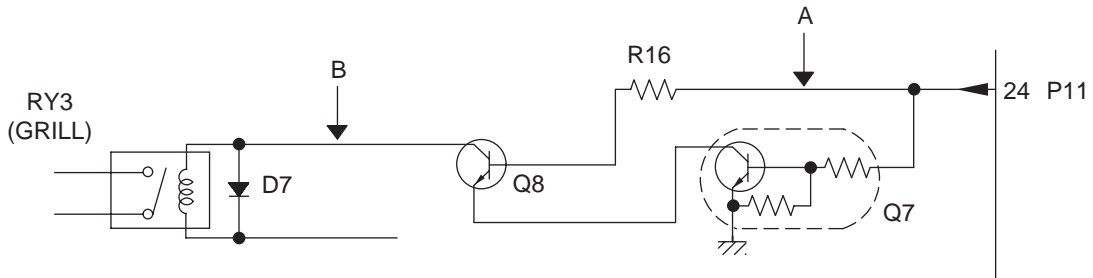

STATE	POINT A	POINT B
RELAY 3 ON	+5V DC	GND
RELAY 3 OFF	GND	12V DC

5. Case of no heating of top heater sub.

When touching GRILL or COMBI or CONVECTION button, oven lamp turns on and Fan motor and turntable rotate and cook indicator in display comes on.

*Cause: **RELAY 4** does not operate.

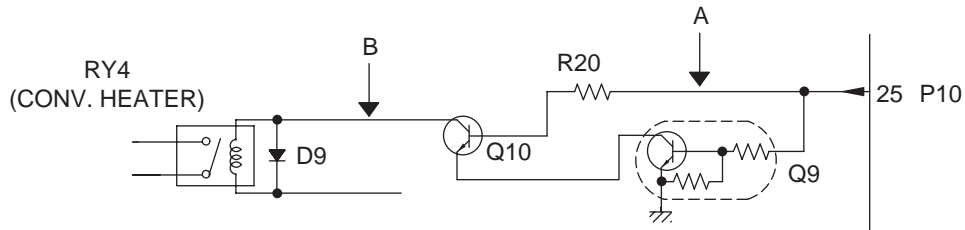

STATE	POINT A	POINT B
RELAY 4 ON	+5V DC	GND
RELAY 4 OFF	GND	12V DC

6. Case of no stopping of the count down timer

When the door is opened during operation, the count down timer does not stop.

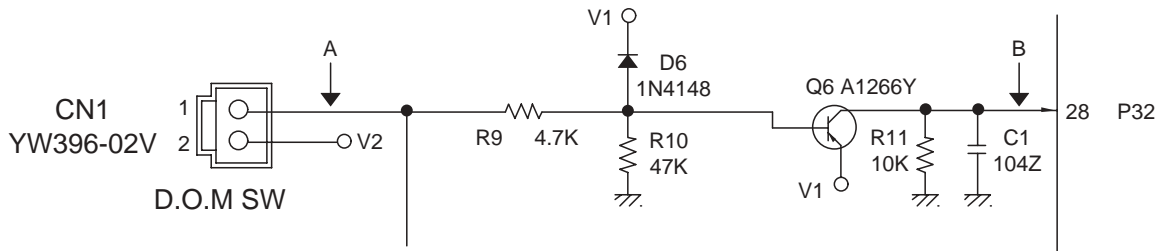

- Check method

STATE \ POINT	A	B
DOOR OPEN	OPEN	+5V DC
DOOR CLOSED	CLOSE	GND

CHECK NO	METHOD	REMEDY
1	Check the stage(ON,OFF) of the door open monitor switch by resistance measurement.	Replace door open monitor switch.

13. P.C.B. CIRCUIT DIAGRAM

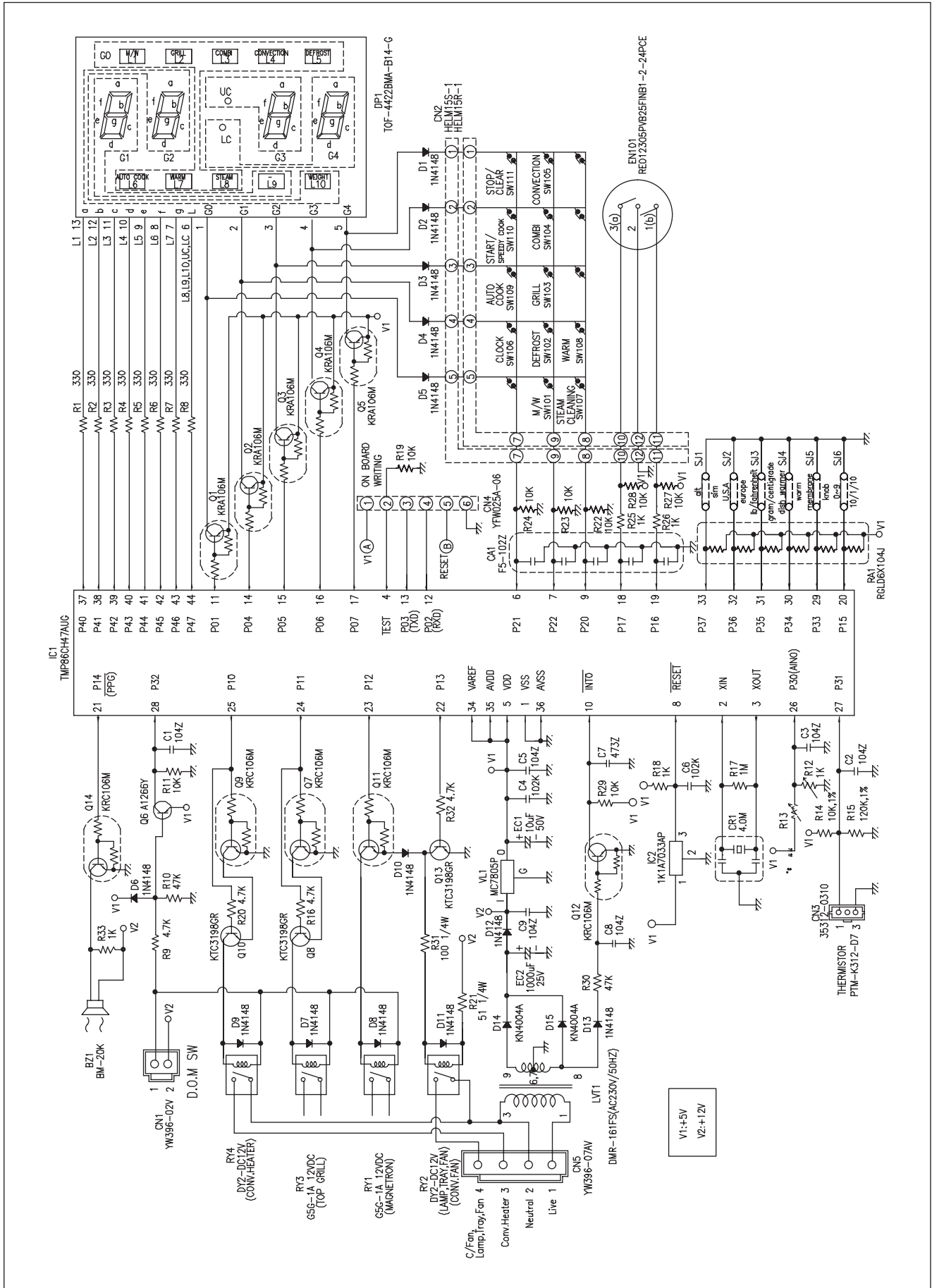

PCB ASS'Y PART LIST

NO	LOCATION	PART CODE	NAME	SPECIFICATION	Q'TY
1	BZ1	3515600100	BUZZER	BM-20K	1
2	CA1	CN5XB-102M	C ARRAY	6P(5) 1000PF M 50V	1
3	C7	CCZF1H473Z	C CERA	50V HIKF 0.047uF Z	1
4	C4,C6	CCZB1H102K	C CERA	102K 50V AXIAL	2
5	C1~3,C5,C8,C9	CCZF1H104Z	C CERA	50V HIKF 0.1uF Z	6
6	EC1	CEXE1H100A	C ELECTRO	50V RSS 10MF	1
7	EC2	CEXF1E102V	C ELECTRO	25V RSS 1000uF	1
8	CN1	3519150520	CONN WAFER	YW396-02V	1
9	CN2	4CW215SBD0	CONN FILM	HLEM15S-1	1
10	CN3	30166M5030	CONN WAFER	MOLEX 35312-0310	1
11	CN5	3519150540	CONN WAFER	YW396-07AV	1
12	D1~D13	DZN4148---	DIODE SWITCHING	1N4148 AUTO 52mm	13
13	D14,D15	DZN4004A--	DIODE RECTIFIER	1N4004A AUTO 52mm	2
14	IC1	13GL86FH47	IC MICOM	TMP86FH47AUG(TMP86CH47AUG)	1
15	IC2	1K1A7033AP	IC RESET	KIA7033AP	1
16	VL1	1CPMC7805C	IC REGULATOR	MC7805C	1
17	DP1	DDDUA9Q0T-	LED DISPLAY	TOF-4422BMA-B14-G	1
18	M298	3514332420	PCB MAIN	BOARD(92.8x197)	1
19	RA1	RA-87X104J	R ARRAY	7P(6) 1/8 100K J	1
20	R1~R8	RD-AZ331J-	R CARBON FILM	1/6 330 OHM 5%	8
21	R12,18,25,26,33	RD-AZ102J-	R CARBON FILM	1/6 1K OHM 5%	5
22	R9,16,20,32	RD-AZ472J-	R CARBON FILM	1/6 4.7K OHM 5%	4
23	R11,19,R22~24,R27~29	RD-AZ103J-	R CARBON FILM	1/6 10K OHM 5%	8
24	R10,30	RD-AZ473J-	R CARBON FILM	1/6 47K OHM 5%	2
25	R17	RD-AZ105J-	R CARBON FILM	1/6 1M OHM 5%	1
26	R21	RD-4Z510J-	R CARBON FILM	1/4 51 OHM 5% SMALL	1
27	R31	RD-4Z101J-	R CARBON FILM	1/4 100 OHM 5% SMALL	1
28	R14	RN-AZ1002F	R METAL FILM	1/6 10K 1%	1
29	R15	RN-AZ1203F	R METAL FILM	1/6 120K 1%	1
30	CR1	5P4R00MTS-	RESONATOR CERA	CRT4.00MS	1
31	RY1,3	5SC0101121	SW RELAY	G5G-1A 1C 1P DC12V	2
32	RY2,4	5SC0101487	SW RELAY	DY2-DC12	2
33	Q1~Q5	TZRA106M--	TR	KRA-106M (AUTO)	5
34	Q7,9,11,12,14	TZRC106M--	TR	KRC-106M (AUTO)	5
35	Q6	TZTA1266Y-	TR	KTA-1266Y (AUTO) (1015Y)	1
36	Q8,10,13	TZTC3198GR	TR	KTC-3198GR (AUTO) (1015Y)	3
37	LVT1	5EPV035308	TRANS POWER	DMR-161FS	1
38	J4,5,8~10,15,21~24, J29~31,33,34	85801052GY	WIRE COPPER	1/0.52 TIN COATING 7.5mm	15
39	J1~3,6,7,11~14,16~20, J28,J32,35~37	85801052GY	WIRE COPPER	1/0.52 TIN COATING 10mm	19
40	M299	3514332520	PCB SUB	BOARD(89x197)	1
41	CN101	4CW215RBD0	CONN WAFER	HLEM15R-1	1
42	EN101	5S10302010	SW ROTARY	RE012305PVB25FINB1-2-24PCE	1
43	SW101~SW111	5S50101Z93	SW TACT	KPT-1115AM	11
44	J101,J102	85801052GY	WIRE COPPER	1/0.52 TIN COATING 10mm	2
45	WF1	WSJ-159007	WIRE FLAT	1.25X15X90XC	1



DAEWOO ELECTRONICS CORP.

1-2, Jeo-dong 1(ii)-ga, Jung-gu, Seoul, Korea

C.P.O. BOX 8003 SEOUL, KOREA

TELEX: DWELEC K28177-8

CABLE: "DAEWOOELEC"

PRINTED DATE: Mar. 2010

S/M NO. :

ABOUT THIS MANUAL

VISION CREATIVE, INC.

서울 종로구 통의동
6번지 이룸빌딩 4층

담 당	박진형 과장님	
MODEL	KOC-9Q3T7S, KOC-9Q4T7S, 9Q4T7WA9 (S/M)	
접 수	2009.09.25	
일 정	1차	
	2차	
	3차	
	4차	
	5차	
제 판	한	인 쇄
규 격		
<p>MEMO 총 46p 09.09.25-전체신규 46p 09.10.14-11p, 12p, 14p, 15p, 17p, 22p, 26p, 31p, 40p, 42p 수정_신규 10p 09.10.27-11p, 12p, 14p, 15p 수정_신규 4p 09.10.29-11p, 12p 수정_신규 2p 10.03.03-표지, 표지뒤 (모델명 추가 KOC-9Q4T7WA9), 3p, 4p, 8p, 12p, 15p, 35p, 36p 수정_신규 9p</p>		

연락처

VISION 담당 방문수

TEL: 730-0660 FAX: 730-3788