

TOSHIBA

FILE NO. 810-200810GR

SERVICE MANUAL



DVD Video Recorder /Video Cassette Recorder ***D-VR60DTKF***

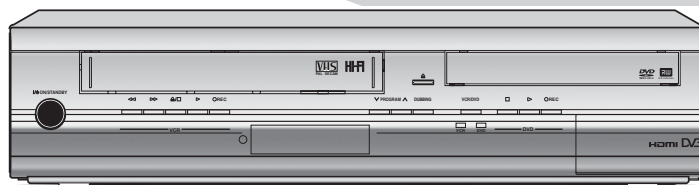

The above model is classified as a green product (*1), as indicated by the underlined serial number. This Service Manual describes replacement parts for the green product. When repairing this green product, use the part(s) described in this manual and lead-free solder (*2).

For (*1) and (*2), see the next page.

(*1)

GREEN PRODUCT PROCUREMENT

The EC is actively promoting the WEEE & RoHS Directives that define standards for recycling and reuse of Waste Electrical and Electronic Equipment and for the Restriction of the use of certain Hazardous Substances. From July 1, 2006, the RoHS Directive will prohibit any marketing of new products containing the restricted substances.

Increasing attention is given to issues related to the global environmental. Toshiba Corporation recognizes environmental protection as a key management tasks, and is doing its utmost to enhance and improve the quality and scope of its environmental activities. In line with this, Toshiba proactively promotes Green Procurement, and seeks to purchase and use products, parts and materials that have low environmental impacts.

Green procurement of parts is not only confined to manufacture. The same green parts used in manufacture must also be used as replacement parts.

(*2)

LEAD-FREE SOLDER

This product is manufactured using lead-free solder as a part of a movement within the consumer products industry at large to be environmentally responsible. Lead-free solder must be used in the servicing and repair of this product.

WARNING

This product is manufactured using lead free solder.

DO NOT USE LEAD BASED SOLDER TO REPAIR THIS PRODUCT !

The melting temperature of lead-free solder is higher than that of leaded solder by 86°F to 104°F (30°C to 40°C). Use of a soldering iron designed for lead-based solders to repair product made with lead-free solder may result in damage to the component and or BOARD being soldered. Great care should be made to ensure high-quality soldering when servicing this product — especially when soldering large components, through-hole pins, and on BOARDS — as the level of heat required to melt lead-free solder is high.

MAIN SECTION

DVD VIDEO RECORDER / VIDEO CASSETTE RECORDER

D-VR60DTKF

Main Section

- Specifications
- Preparation for Servicing
- Adjustment Procedures
- Schematic Diagrams
- BOARD's
- Exploded Views
- Parts List

TABLE OF CONTENTS

Specifications	1-1-1
Laser Beam Safety Precautions	1-2-1
Important Safety Precautions	1-3-1
Standard Notes for Servicing	1-4-1
Preparation for Servicing	1-5-1
Cabinet Disassembly Instructions	1-6-1
Electrical Adjustment Instructions	1-7-1
How to Initialize the DVD Recorder & VCR	1-8-1
Firmware Renewal Mode	1-9-1
Remote Control Key Code	1-9-2
Troubleshooting	1-10-1
Function Indicator Symbols	1-11-1
Block Diagrams	1-12-1
Schematic Diagrams / BOARD's and Test Points	1-13-1
Waveforms	1-14-1
Wiring Diagram	1-15-1
IC Pin Function Descriptions	1-16-1
Lead Identifications	1-17-1
Exploded Views	1-18-1
Mechanical Parts List	1-19-1
Electrical Parts List	1-20-1

Manufactured under license from Dolby Laboratories.
Dolby and the double-D symbol are trademarks of Dolby Laboratories.

SPECIFICATIONS

General	
System	DVD-Video, DVD-RW/-R, DVD+RW/+R, Video CD, CD-DA, CD-RW/-R, Video Cassette Tape
VHS video heads	Four heads
Power requirements	220–240 V ~ ± 10%, 50 Hz ± 0.5%
Power consumption	35 W (standby: 5.0 W)
Weight	4.9 kg
Dimensions (width x height x depth)	435 x 99.5 x 388 mm
Operating temperature	5°C to 40°C
Operating humidity	Less than 80% (no condensation)
TV format	SECAM LL', PAL B / G

Recording	
Recording format	Video Recording (VR) format (DVD-RW only), Video format (DVD-RW, DVD-R) +VR format (DVD+RW, DVD+R)
Recordable discs	DVD-ReWritable, DVD-Recordable, DVD+ReWritable, DVD+Recordable
Video recording format	
Sampling frequency	13.5 MHz
Compression format	MPEG
Audio recording format	
Sampling frequency	48 kHz
Compression format	Dolby Digital

Tuner	
Analogue channels	
L (SECAM L)	F1 - E69
BG (PAL B/G)	E2 - E69
DVB-T channels	
VHF	F5 - F10
UHF	E21 - E69

Input/Output	
Front Panel : (AV3)	
Video input	One RCA connector
Input level	1Vp-p (75 Ω)
Audio input	Two RCA connectors
Input level	2Vrms (input impedance: more than 10kΩ)
DV input	IEEE 1394
DV 4-pin jack	
Rear Panel :	
VHF/UHF antenna input/output terminal	VHF/UHF set 75 Ω
Audio input /output	Two 21-pin scart sockets (AV1, AV2)
Video input /output	Two 21-pin scart sockets (AV1, AV2)
Input /output level	1Vp-p (75 Ω) each
Component video output	Three RCA connectors
Output level	Y: 1.0Vp-p (75 Ω) PB/CB, PR/CR: 0.7Vp-p (75 Ω) each
Audio output	Two RCA connectors
Output level	2Vrms (output impedance: 680 Ω)
Digital audio output	One Coaxial pin jack
Output level	500mVp-p (75 Ω)
HDMI output	HDMI jack

Note

The specifications and design of this product are subject to change without notice.

LASER BEAM SAFETY PRECAUTIONS

This DVD player uses a pickup that emits a laser beam.

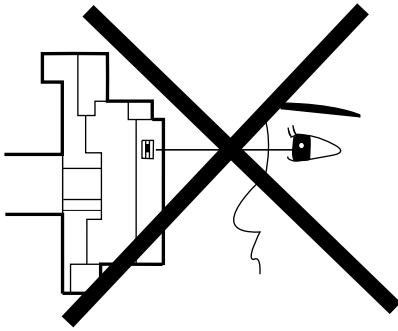

Do not look directly at the laser beam coming from the pickup or allow it to strike against your skin.

The laser beam is emitted from the location shown in the figure. When checking the laser diode, be sure to keep your eyes at least 30 cm away from the pickup lens when the diode is turned on. Do not look directly at the laser beam.

CAUTION: Use of controls and adjustments, or doing procedures other than those specified herein, may result in hazardous radiation exposure.

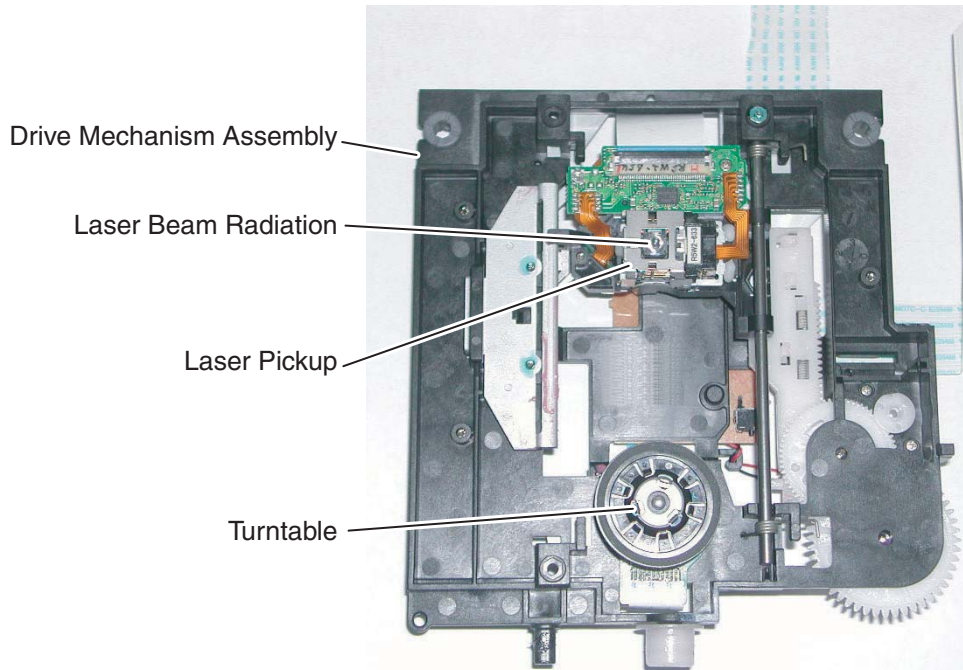

CAUTION-CLASS 2M LASER
RADIATION WHEN OPEN
DO NOT STARE INTO THE BEAM
OR VIEW DIRECTLY WITH
OPTICAL INSTRUMENTS



Location: Inside Top of DVD mechanism.

IMPORTANT SAFETY PRECAUTIONS

Product Safety Notice

Some electrical and mechanical parts have special safety-related characteristics which are often not evident from visual inspection, nor can the protection they give necessarily be obtained by replacing them with components rated for higher voltage, wattage, etc. Parts that have special safety characteristics are identified by a \triangle on schematics and in parts lists. Use of a substitute replacement that does not have the same safety characteristics as the recommended replacement part might create shock, fire, and/or other hazards. The Product's Safety is under review continuously and new instructions are issued whenever appropriate. Prior to shipment from the factory, our products are carefully inspected to confirm with the recognized product safety and electrical codes of the countries in which they are to be sold. However, in order to maintain such compliance, it is equally important to implement the following precautions when a set is being serviced.

Precautions during Servicing

- A.** Parts identified by the \triangle symbol are critical for safety. Replace only with part number specified.
- B.** In addition to safety, other parts and assemblies are specified for conformance with regulations applying to spurious radiation. These must also be replaced only with specified replacements.
Examples: RF converters, RF cables, noise blocking capacitors, and noise blocking filters, etc.
- C.** Use specified internal wiring. Note especially:
 - 1) Wires covered with PVC tubing
 - 2) Double insulated wires
 - 3) High voltage leads
- D.** Use specified insulating materials for hazardous live parts. Note especially:
 - 1) Insulation tape
 - 2) PVC tubing
 - 3) Spacers
 - 4) Insulators for transistors
- E.** When replacing AC primary side components (transformers, power cord, etc.), wrap ends of wires securely about the terminals before soldering.
- F.** Observe that the wires do not contact heat producing parts (heatsinks, oxide metal film resistors, fusible resistors, etc.).
- G.** Check that replaced wires do not contact sharp edges or pointed parts.
- H.** When a power cord has been replaced, check that 5 - 6 kg of force in any direction will not loosen it.
- I.** Also check areas surrounding repaired locations.
- J.** Be careful that foreign objects (screws, solder droplets, etc.) do not remain inside the set.
- K.** When connecting or disconnecting the internal connectors, first, disconnect the AC plug from the AC outlet.
- L.** Be sure to confirm the FAN motor has completely stopped when disconnecting the AC cord for termination processing is activated during inner P-on immediately after turning Power off.

Safety Check after Servicing

Examine the area surrounding the repaired location for damage or deterioration. Observe that screws, parts, and wires have been returned to their original positions. Afterwards, do the following tests and confirm the specified values to verify compliance with safety standards.

1. Clearance Distance

When replacing primary circuit components, confirm specified clearance distance (d) and (d') between soldered terminals, and between terminals and surrounding metallic parts. (See Fig. 1)

Table 1 : Ratings for selected area

AC Line Voltage	Clearance Distance (d), (d')
230 V	$\geq 3.2 \text{ mm}(d)$ $\geq 6.0 \text{ mm}(d')$

Note: This table is unofficial and for reference only. Be sure to confirm the precise values.

2. Leakage Current Test

Confirm the specified (or lower) leakage current between B (earth ground, power cord plug prongs) and externally exposed accessible parts (RF terminals, antenna terminals, video and audio input and output terminals, microphone jacks, earphone jacks, etc.) is lower than or equal to the specified value in the table below.

Measuring Method (Power ON) :

Insert load Z between B (earth ground, power cord plug prongs) and exposed accessible parts. Use an AC voltmeter to measure across the terminals of load Z. See Fig. 2 and the following table.

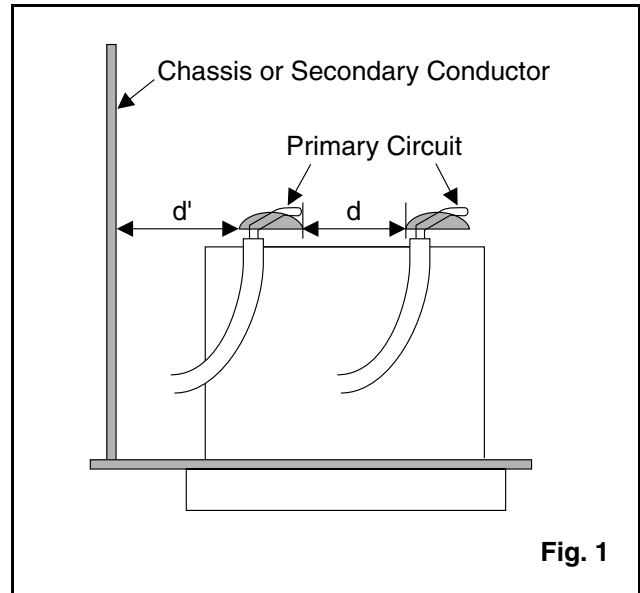

Fig. 1

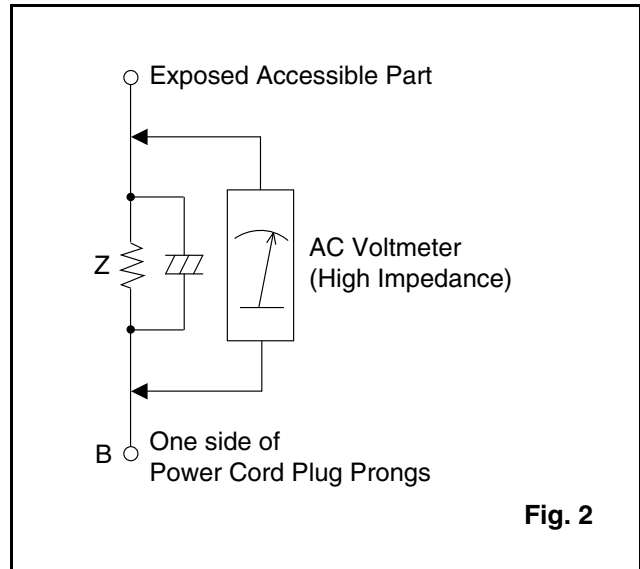

Fig. 2

Table 2: Leakage current ratings for selected areas

AC Line Voltage	Load Z	Leakage Current (i)	One side of power cord plug prongs (B) to:
230 V	2kΩ RES. Connected in parallel	$i \leq 0.7 \text{ mA AC Peak}$ $i \leq 2 \text{ mA DC}$	RF or Antenna terminals
	50kΩ RES. Connected in parallel	$i \leq 0.7 \text{ mA AC Peak}$ $i \leq 2 \text{ mA DC}$	A/V Input, Output

Note: This table is unofficial and for reference only. Be sure to confirm the precise values.

STANDARD NOTES FOR SERVICING

NOTE: BOARD MEANS PRINTED CIRCUIT BOARD.

Circuit Board Indications

1. The output pin of the 3 pin Regulator ICs is indicated as shown.

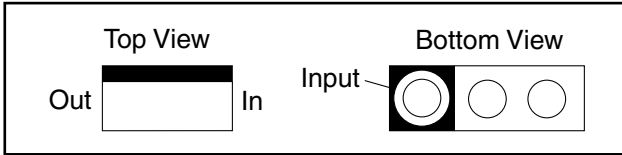

2. For other ICs, pin 1 and every fifth pin are indicated as shown.

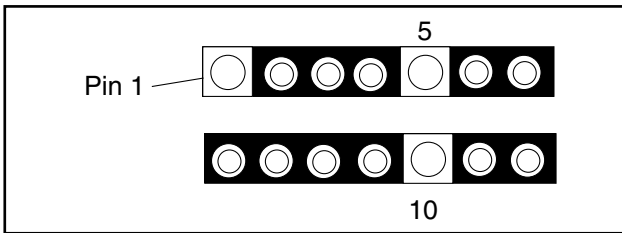

3. The 1st pin of every male connector is indicated as shown.

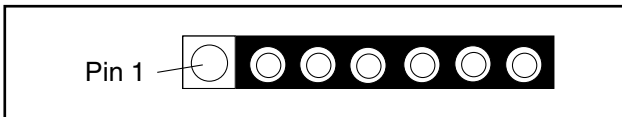

Instructions for Connectors

1. When you connect or disconnect the FFC (Flexible Foil Connector) cable, be sure to first disconnect the AC cord.
2. FFC (Flexible Foil Connector) cable should be inserted parallel into the connector, not at an angle.

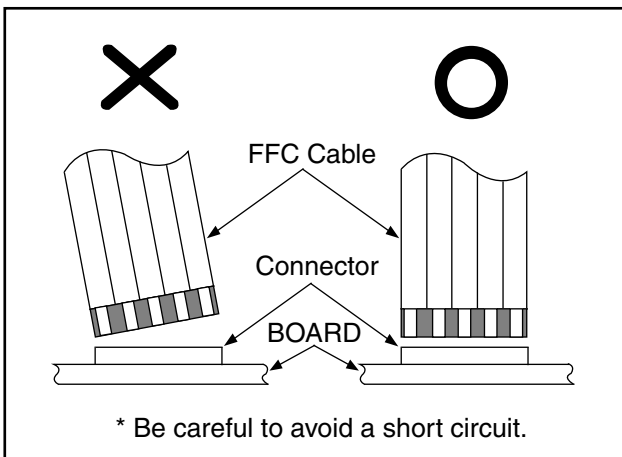

Pb (Lead) Free Solder

When soldering, be sure to use the Pb free solder.

How to Remove / Install Flat Pack-IC

1. Removal

With Hot-Air Flat Pack-IC Desoldering Machine:

1. Prepare the hot-air flat pack-IC desoldering machine, then apply hot air to the Flat Pack-IC (about 5 to 6 seconds). (Fig. S-1-1)

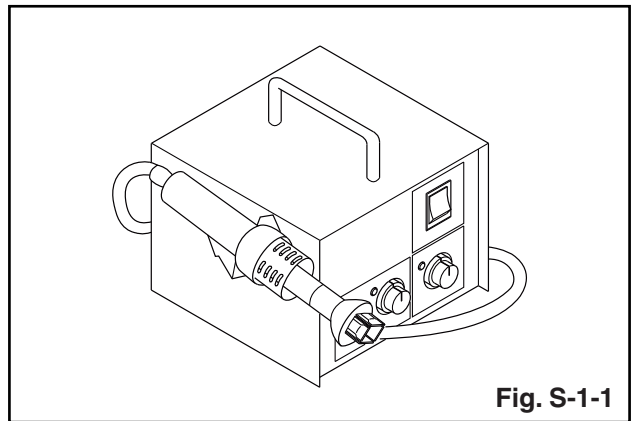

2. Remove the flat pack-IC with tweezers while applying the hot air.
3. Bottom of the flat pack-IC is fixed with glue to the BOARD; when removing entire flat pack-IC, first apply soldering iron to center of the flat pack-IC and heat up. Then remove (glue will be melted). (Fig. S-1-6)
4. Release the flat pack-IC from the BOARD using tweezers. (Fig. S-1-6)

CAUTION:

1. The Flat Pack-IC shape may differ by models. Use an appropriate hot-air flat pack-IC desoldering machine, whose shape matches that of the Flat Pack-IC.
2. Do not supply hot air to the chip parts around the flat pack-IC for over 6 seconds because damage to the chip parts may occur. Put masking tape around the flat pack-IC to protect other parts from damage. (Fig. S-1-2)

3. The flat pack-IC on the BOARD is affixed with glue, so be careful not to break or damage the foil of each pin or the solder lands under the IC when removing it.

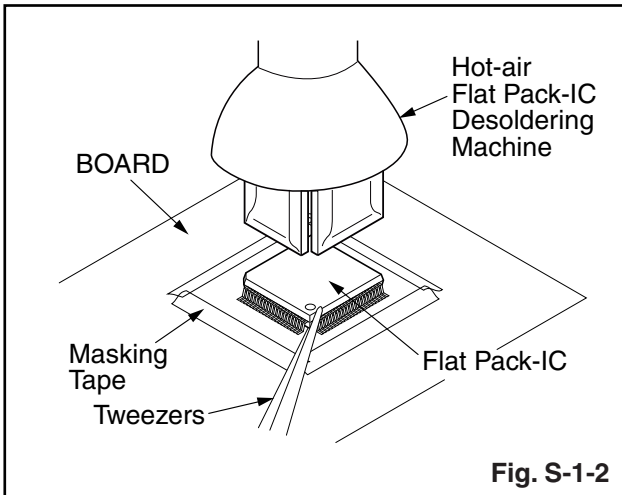

With Soldering Iron:

1. Using desoldering braid, remove the solder from all pins of the flat pack-IC. When you use solder flux which is applied to all pins of the flat pack-IC, you can remove it easily. (Fig. S-1-3)

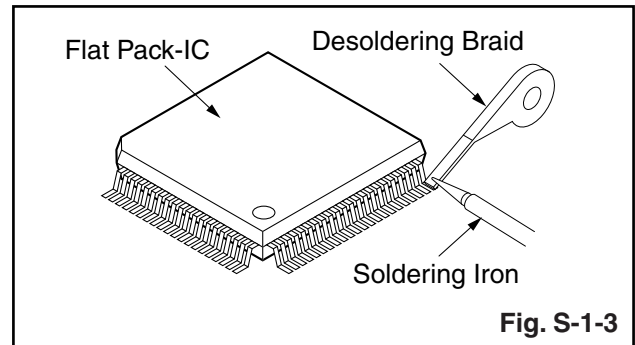

2. Lift each lead of the flat pack-IC upward one by one, using a sharp pin or wire to which solder will not adhere (iron wire). When heating the pins, use a fine tip soldering iron or a hot air desoldering machine. (Fig. S-1-4)

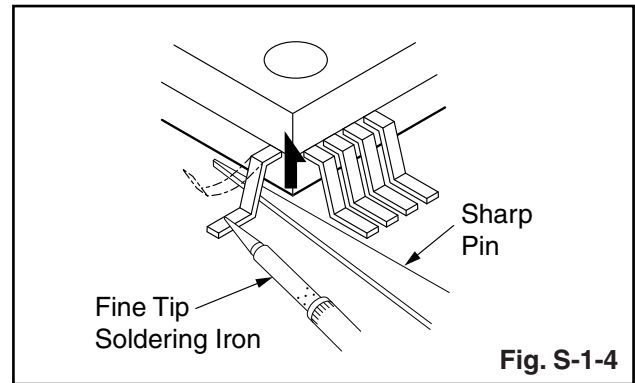

3. Bottom of the flat pack-IC is fixed with glue to the BOARD; when removing entire flat pack-IC, first apply soldering iron to center of the flat pack-IC and heat up. Then remove (glue will be melted). (Fig. S-1-6)
4. Release the flat pack-IC from the BOARD using tweezers. (Fig. S-1-6)

With Iron Wire:

1. Using desoldering braid, remove the solder from all pins of the flat pack-IC. When you use solder flux which is applied to all pins of the flat pack-IC, you can remove it easily. (Fig. S-1-3)
2. Affix the wire to a workbench or solid mounting point, as shown in Fig. S-1-5.
3. While heating the pins using a fine tip soldering iron or hot air blower, pull up the wire as the solder melts so as to lift the IC leads from the BOARD contact pads as shown in Fig. S-1-5.
4. Bottom of the flat pack-IC is fixed with glue to the BOARD; when removing entire flat pack-IC, first apply soldering iron to center of the flat pack-IC and heat up. Then remove (glue will be melted). (Fig. S-1-6)
5. Release the flat pack-IC from the BOARD using tweezers. (Fig. S-1-6)

Note: When using a soldering iron, care must be taken to ensure that the flat pack-IC is not being held by glue. When the flat pack-IC is removed from the BOARD, handle it gently because it may be damaged if force is applied.

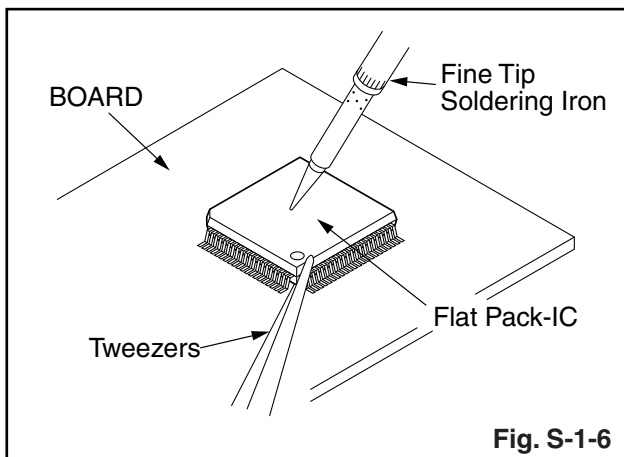
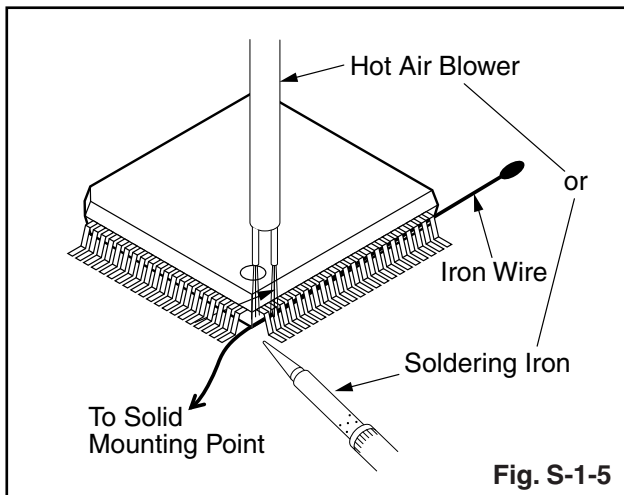

2. Installation

1. Using desoldering braid, remove the solder from the foil of each pin of the flat pack-IC on the BOARD so you can install a replacement flat pack-IC more easily.
2. The "●" mark on the flat pack-IC indicates pin 1. (See Fig. S-1-7.) Be sure this mark matches the 1 on the BOARD when positioning for installation. Then presolder the four corners of the flat pack-IC. (See Fig. S-1-8.)
3. Solder all pins of the flat pack-IC. Be sure that none of the pins have solder bridges.

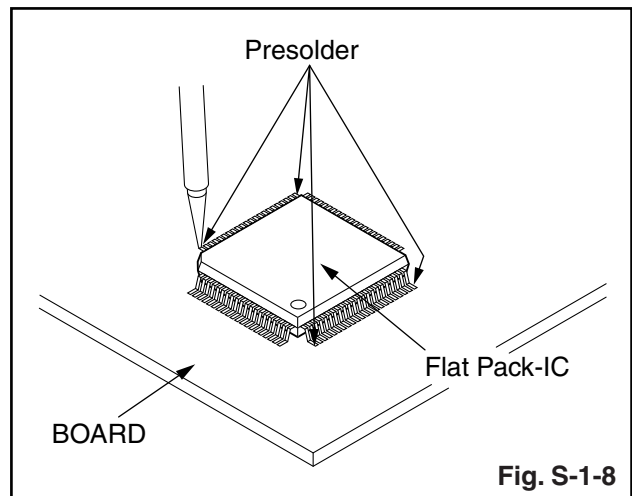
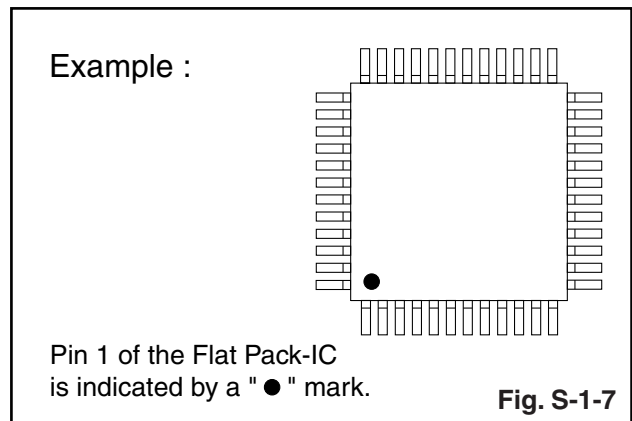

Instructions for Handling Semi-conductors

Electrostatic breakdown of the semi-conductors may occur due to a potential difference caused by electrostatic charge during unpacking or repair work.

1. Ground for Human Body

Be sure to wear a grounding band ($1\text{ M}\Omega$) that is properly grounded to remove any static electricity that may be charged on the body.

2. Ground for Workbench

Be sure to place a conductive sheet or copper plate with proper grounding ($1\text{ M}\Omega$) on the workbench or other surface, where the semi-conductors are to be placed. Because the static electricity charge on clothing will not escape through the body grounding band, be careful to avoid contacting semi-conductors with your clothing.

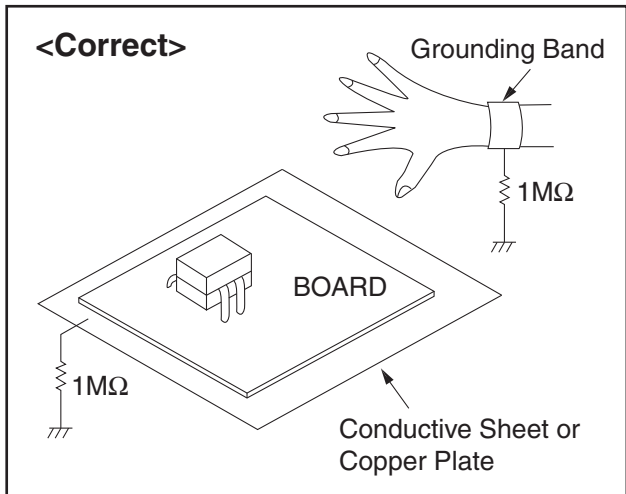
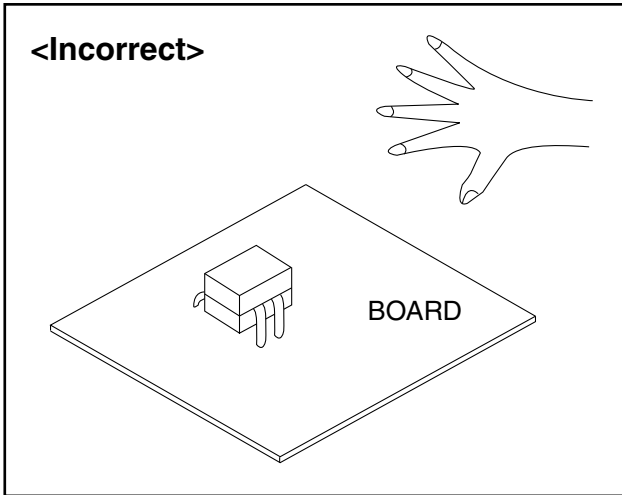

PREPARATION FOR SERVICING

How to Enter the Service Mode

About Optical Sensors

Caution:

An optical sensor system is used for the Tape Start and End Sensors on this equipment. Carefully read and follow the instructions below. Otherwise the unit may operate erratically.

What to do for preparation

Insert a tape into the Deck Mechanism Assembly and press [VCR PLAY] button. The tape will be loaded into the Deck Mechanism Assembly. Make sure the power is on, connect J303 to GND. This will stop the function of Tape Start Sensor, Tape End Sensor and Reel Sensors. (If these TPs are connected before plugging in the unit, the function of the sensors will stay valid.) See Fig. 1.

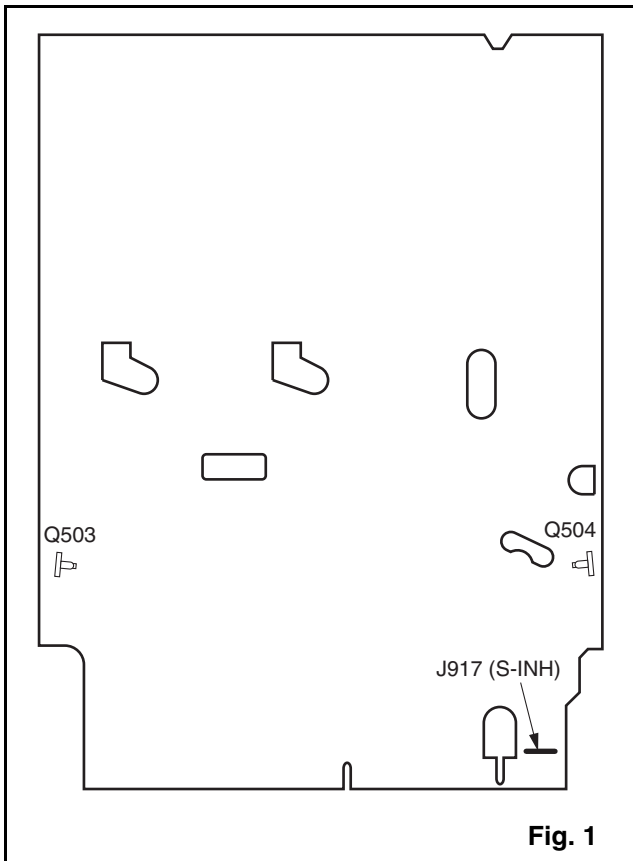

Fig. 1

Note: Because the Tape End Sensors are inactive, do not run a tape all the way to the start or the end of the tape to avoid tape damage.

CABINET DISASSEMBLY INSTRUCTIONS

NOTE: BOARD MEANS PRINTED CIRCUIT BOARD.

1. Disassembly Flowchart

This flowchart indicates the disassembly steps to gain access to item(s) to be serviced. When reassembling, follow the steps in reverse order. Bend, route, and dress the cables as they were originally.

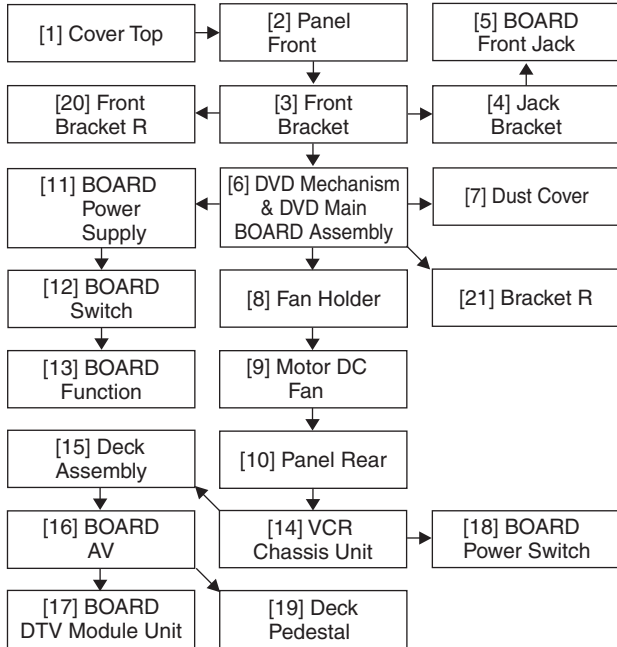

2. Disassembly Method

ID/ LOC. No.	PART	REMOVAL		
		Fig. No.	REMOVE/*UNHOOK/ UNLOCK/RELEASE/ UNPLUG/DESOLDER	Note
[1]	Cover Top	D1	7(S-1)	---
[2]	Panel Front	D2	(S-2), *5(L-1), *3(L-2), *CN1231	1 1-1 1-2 1-3
[3]	Front Bracket	D2	3(S-3), (S-4), Front Support	---
[4]	Jack Bracket	D3	(S-5)	---
[5]	BOARD Front Jack	D3	Jack Plate Earth	---
[6]	DVD Mechanism & DVD Main BOARD Assembly	D4	(S-6), 2(S-7), 2(S-8), 2(S-9), *CN101, *CN502-D, *CN701, *CN901, Mecha Plate Earth	4
[7]	Dust Cover	D4	Hook	---
[8]	Fan Holder	D5	2(S-10), *CN1002	---
[9]	Motor DC Fan	D5	2(S-11)	---

ID/ LOC. No.	PART	REMOVAL		
		Fig. No.	REMOVE/*UNHOOK/ UNLOCK/RELEASE/ UNPLUG/DESOLDER	Note
[10]	Panel Rear	D5	2(S-12), 2(S-13)	---
[11]	BOARD Power Supply	D6	(S-14), 3(S-15), 2(S-16), *CN1503, FFC Guide	---
[12]	BOARD Switch	D6	(S-17), (S-18), *CN3001, Front Pedestal	---
[13]	BOARD Function	D6	(S-19), Desolder	---
[14]	VCR Chassis Unit	D7	5(S-20), 4(S-21), (S-22)	---
[15]	Deck Assembly	D8	(S-23), (S-24), (S-25) Desolder	2 3
[16]	BOARD AV	D8	-----	---
[17]	BOARD DTV Module Unit	D8	Desolder	---
[18]	BOARD Power Switch	D8	Desolder	---
[19]	Deck Pedestal	D9	7(S-26)	---
[20]	Front Bracket R	D9	(S-27), 2(S-28), DV Cable, DV Plate Earth	---
[21]	Bracket R	D9	2(S-29)	---

↓ ↓ ↓ ↓ ↓
 (1) (2) (3) (4) (5)

Note:

- (1): Identification (location) No. of parts in the figures
- (2): Name of the part
- (3): Figure Number for reference
- (4): Identification of parts to be removed, unhooked, unlocked, released, unplugged, unclamped, or desoldered.
P=Spring, L=Locking Tab, S=Screw, CN=Connector
*=Unhook, Unlock, Release, Unplug, or Desolder
e.g. 6(S-1) = six Screws (S-1),
5(L-1) = five Locking Tabs (L-1)
- (5): Refer to "Reference Notes."

Reference Notes

CAUTION 1: Locking Tabs (L-1) and (L-2) are fragile. Be careful not to break them.

- 1-1. Release five Locking Tabs (L-1).
- 1-2. Release three Locking Tabs (L-2).
- 1-3. Disconnect Connector (CN1231) and remove the Panel Front.
2. When reassembling, solder wire jumpers as shown in Fig. D8.
3. Before installing the Deck Assembly, be sure to place the pin of LD-SW on BOARD AV as shown in Fig. D8. Then, install the Deck Assembly while aligning the hole of Cam Gear with the pin of LD-SW, the shaft of Cam Gear with the hole of LD-SW as shown in Fig. D8.
4. **The DVD Mechanism & DVD Main BOARD Assembly is adjusted as a unit at factory. Therefore, do not disassemble it. Replace the DVD Mechanism & DVD Main BOARD Assembly as a unit.**

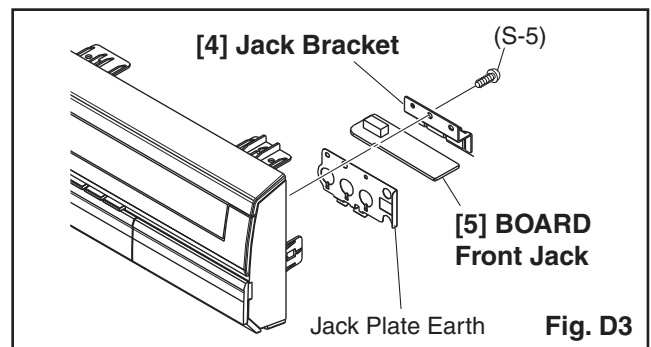
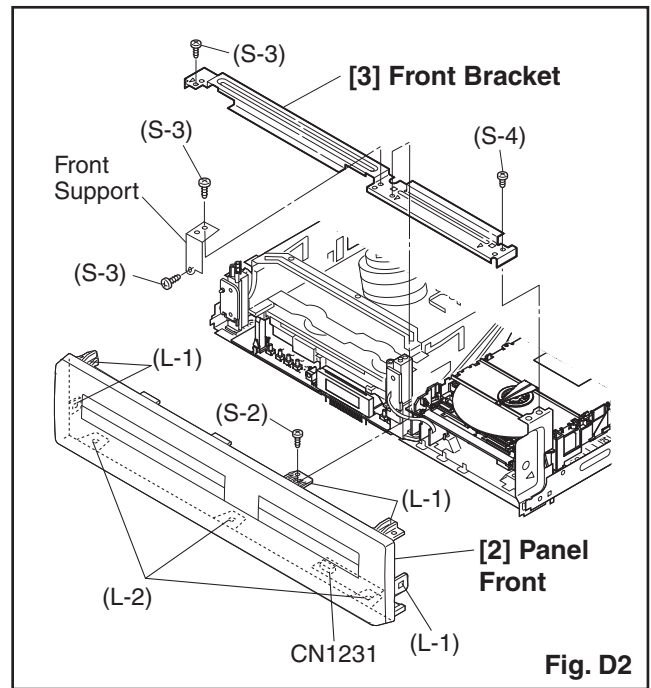
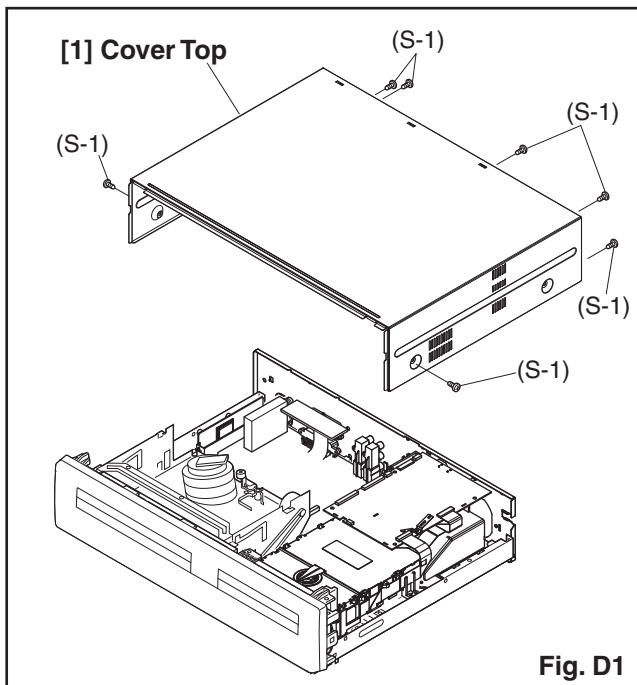

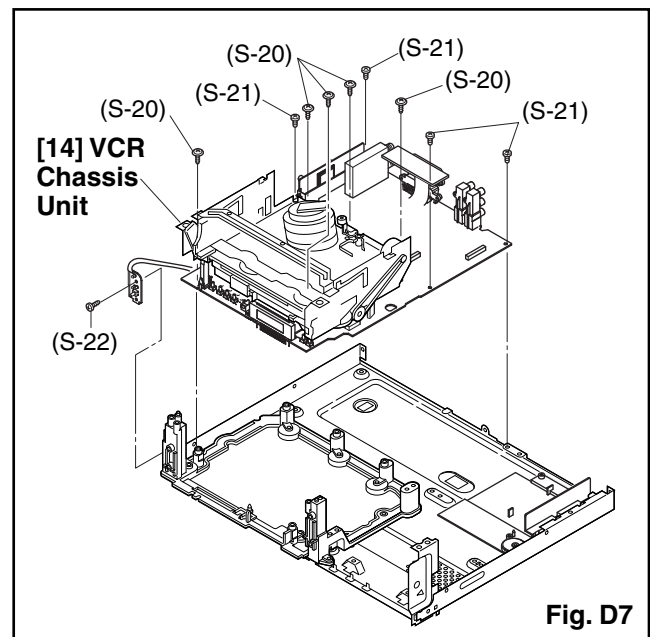
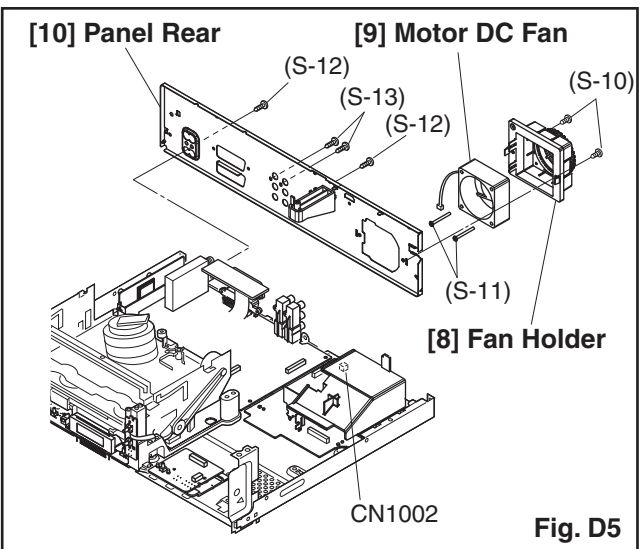
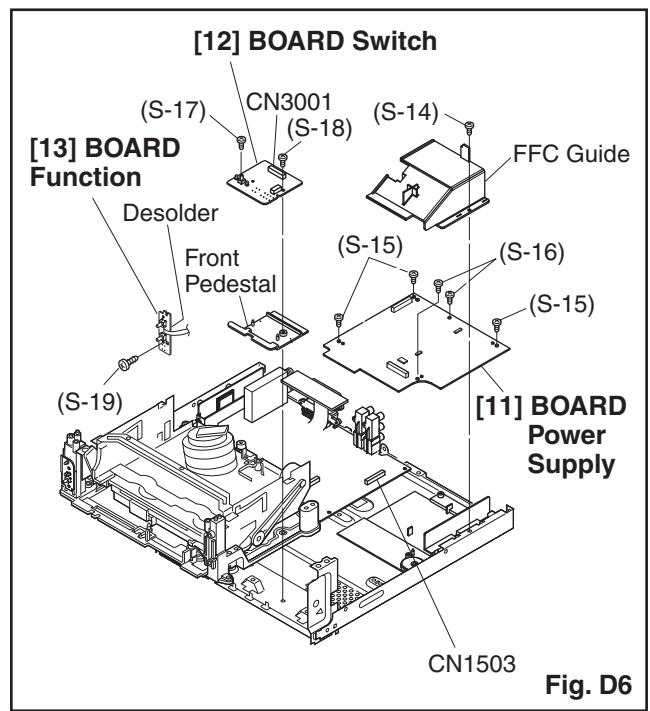
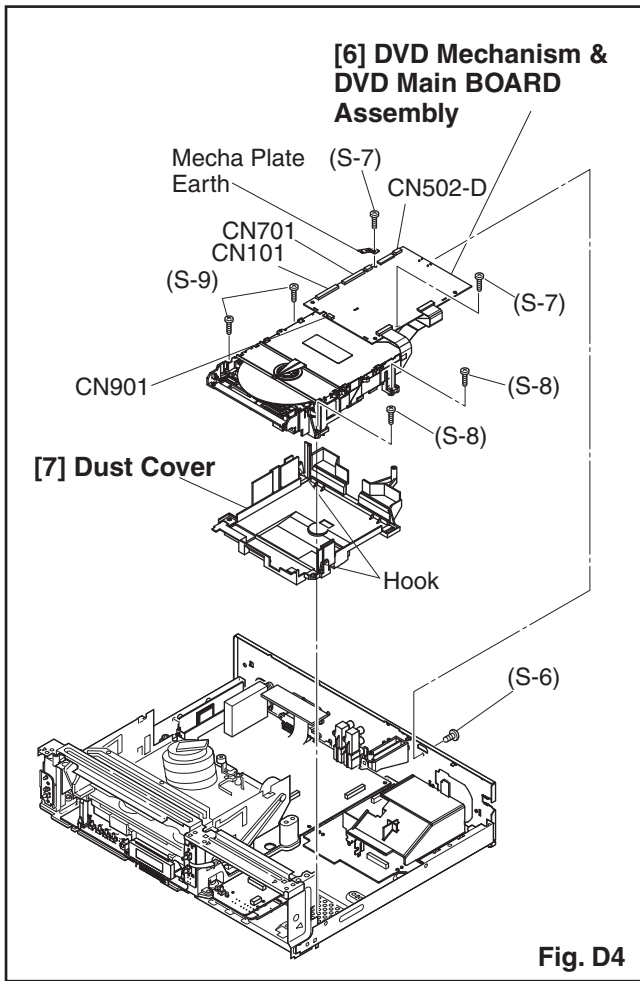

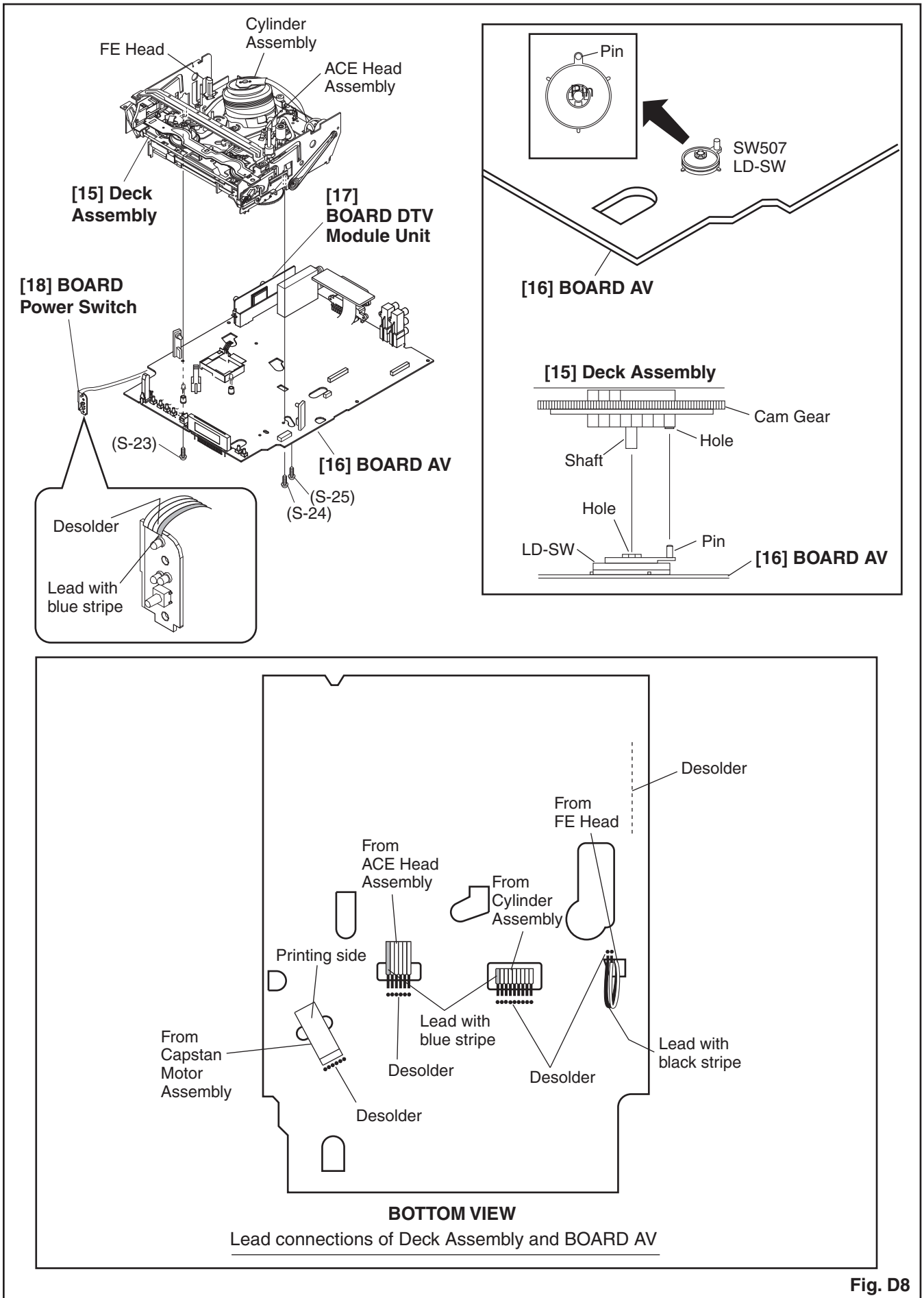
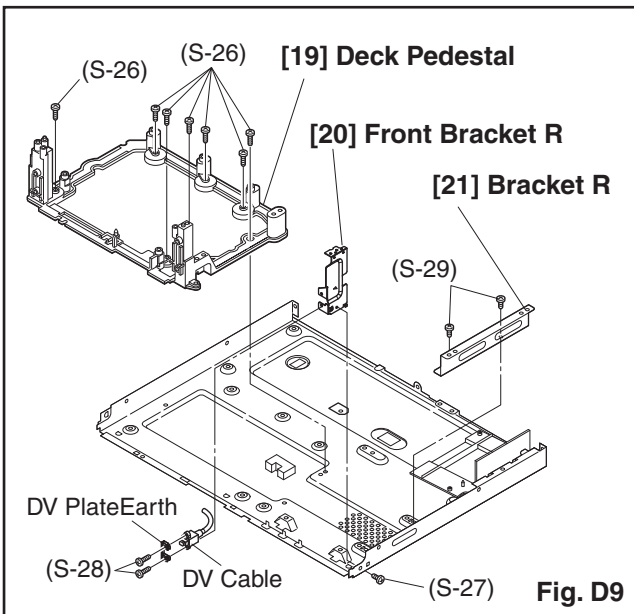

Fig. D8



3. How to Eject Manually

Note: When rotating the gear, be careful not to damage the gear.

1. Remove the Cover Top, Panel Front, Front Bracket, DVD Mechanism & DVD Main BOARD Assembly.
2. Remove the Dust Cover.
3. Rotate the gear in the direction of the arrow manually as shown below.
4. Pull the tray out manually and remove a disc.

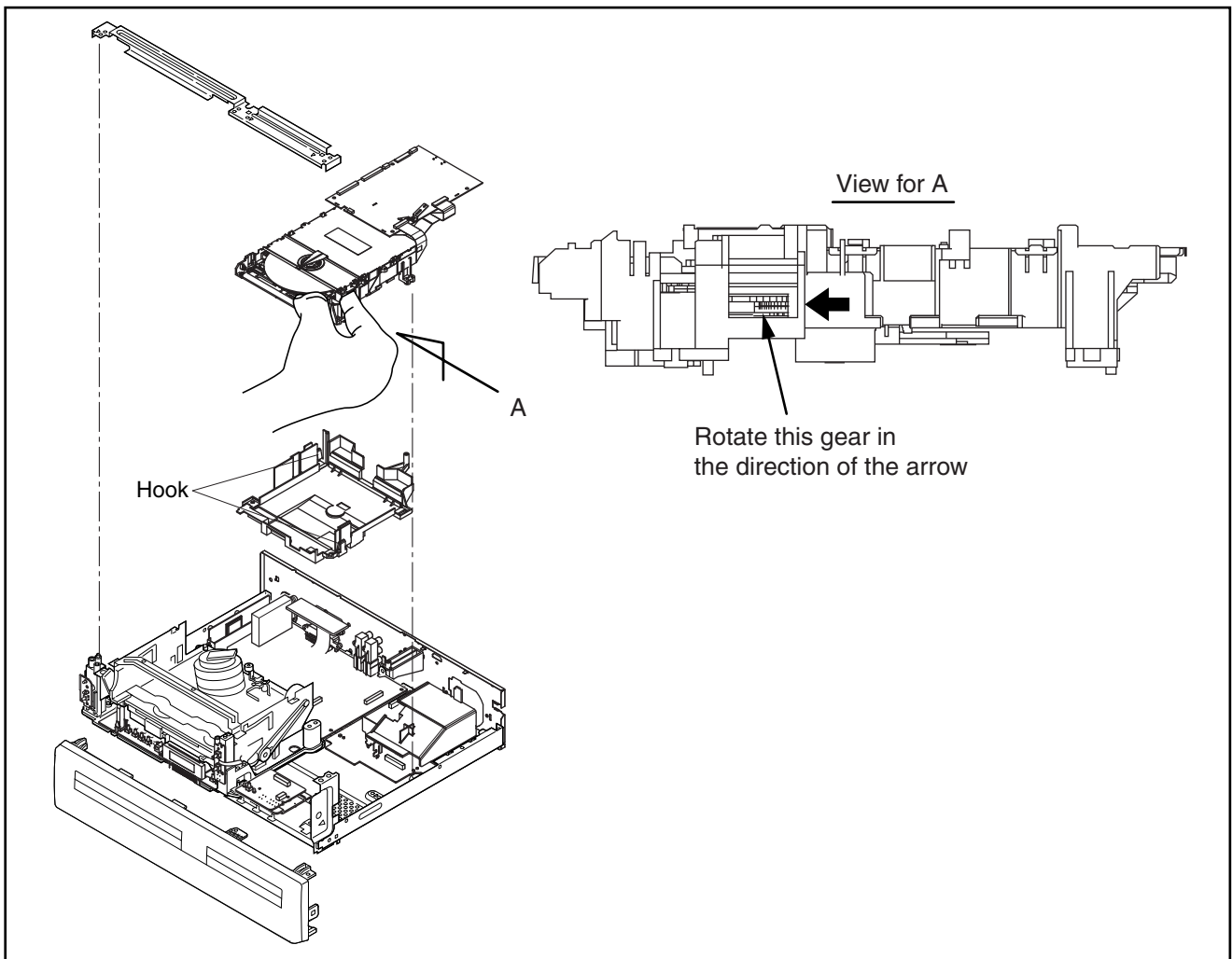

ELECTRICAL ADJUSTMENT INSTRUCTIONS

NOTE: BOARD MEANS PRINTED CIRCUIT BOARD.

NOTE:

1. Electrical adjustments are required after replacing circuit components and certain mechanical parts. It is important to do these adjustments only after all repairs and replacements have been completed. Also, do not attempt these adjustments unless the proper equipment is available.
2. To perform these alignment / confirmation procedures, make sure that the tracking control is set in the center position: Press either [PROGRAM ∇] or [PROGRAM \wedge] button on the front panel first, then the [\blacktriangleright] (VCR) button on the front panel.

Test Equipment Required

1. Oscilloscope: Dual-trace with 10:1 probe,
V-Range: 0.001~50V/Div.,
F-Range: DC~AC-20MHz
2. Alignment Tape (FL6A)

Head Switching Position Adjustment

Purpose:

To determine the Head Switching position during playback.

Symptom of Misadjustment:

May cause Head Switching noise or vertical jitter in the picture.

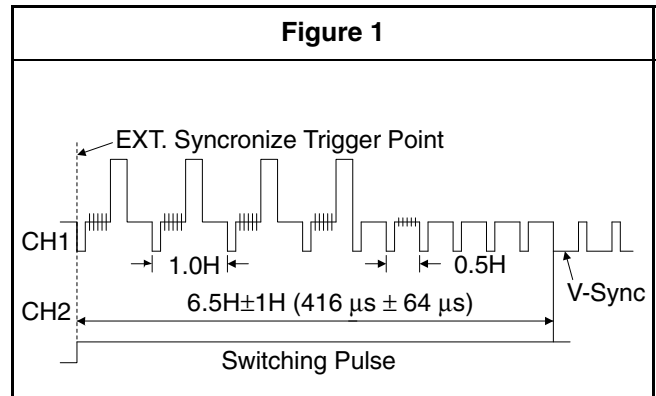

Reference Notes:

Playback the Alignment tape and adjust VR501 so that the V-sync front edge of the CH1 video output waveform is at the $6.5H \pm 1H$ ($416\mu s \pm 64\mu s$) delayed position from the rising edge of the CH2 head switching pulse waveform.

Test point	Adj. Point	Mode	Input
J184(AV1-V-OUT) TP504(RF-SW) GND	VR501 (Switching Point) (BOARD AV)	PLAY (SP)	----
Tape	Measurement Equipment	Spec.	
FL6A	Oscilloscope	$6.5H \pm 1H$ ($416\mu s \pm 64\mu s$)	

Connections of Measurement Equipment

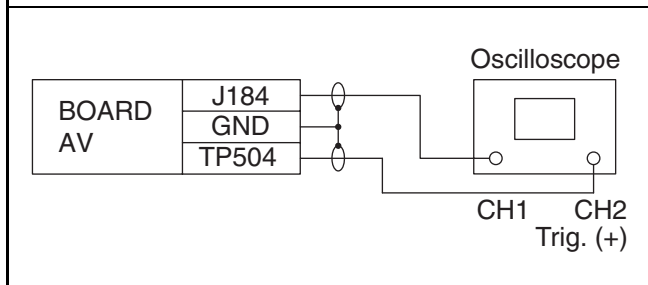

HOW TO INITIALIZE THE DVD RECORDER & VCR

To put the program back at the factory-default, initialize the DVD recorder & VCR as the following procedure.

< DVD Section >

1. Turn the DVD recorder on.
2. Confirm that no disc is loaded or that the disc tray is open. To put the DVD recorder into the Version display mode, press [DVD], [INSTANT SKIP], [1], [2], and [3] buttons on the remote control unit in that order.

Fig. a appears on the screen.

*1: "*****" differs depending on the models.

*2: Firmware Version differs depending on the models, and this indication is one example.

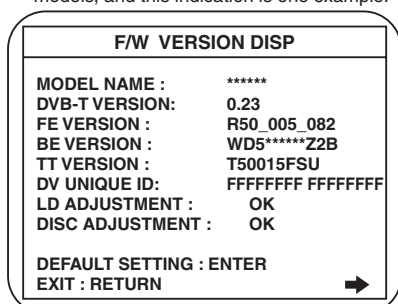

Fig. a Version Display Mode Screen

3. Press [ENTER] button, then the DVD recorder starts initializing. When the initializing is completed, the DVD recorder exits the Version display mode and turns off the power automatically.
- * To move into the Normal mode from the Version display mode, press [RETURN] button on the remote control unit instead of [ENTER] button.
 - * When [I/⏻] button is pressed before [ENTER] button is pressed, the DVD recorder exits the Version display mode, then the power turns off.

FIRMWARE RENEWAL MODE

1. Turn the power on and remove the disc on the tray.
2. To put the DVD recorder into version up mode, press [INSTANT SKIP], [6], [5], and [4] buttons on the remote control unit in the order. Then the tray will open automatically.

Fig. a appears on the screen and Fig. b appears on the VFD.

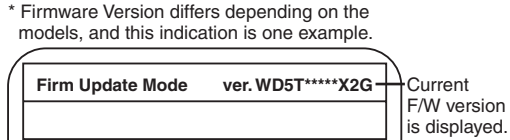

Fig. a Version Up Mode Screen

F - UP

Fig. b VFD in Version Up Mode

3. Load the disc for version up.
Fig. c appears on the screen. The file on the top is highlighted as the default.
When there is only one file to exist, Step 4 will start automatically.

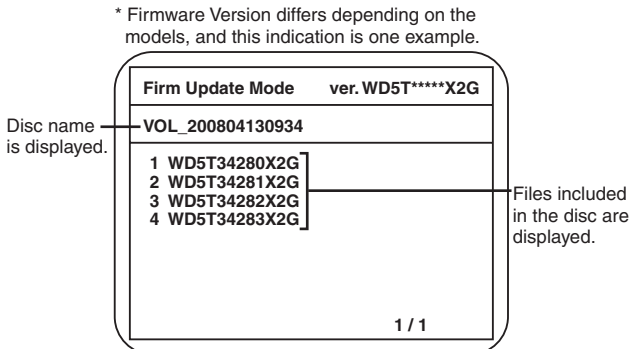

Fig. c Update Disc Screen

4. Select the firmware version pressing arrow buttons, then press [ENTER].
Fig. d appears on the screen and Fig. e appears on the VFD. The DVD recorder starts updating.

About VFD indication of Fig. e:

- 1) When Fig. d is displayed on the screen, "F-UP" is displayed on the VFD.
- 2) When "Firmware Updating... XX% Complete." is displayed on the screen, "34280" is displayed on the VFD.

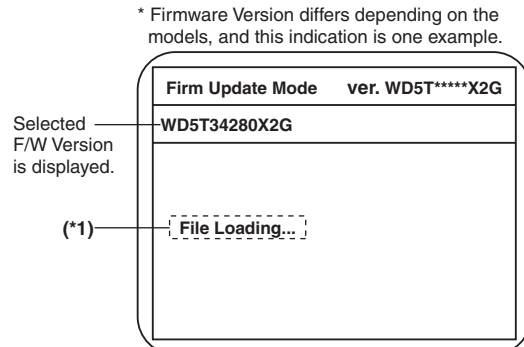

Fig. d Programming Mode Screen

34280

Fig. e VFD in Programming Mode (Example)

The appearance shown in (*1) of Fig. d is described as follows.

No.	Appearance	State
1	File Loading...	Sending files into the memory
2	Firmware Updating... XX% Complete.	Writing new version data
---	Firmware Update Failure	Failed in updating

5. After updating is finished, the tray opens automatically.
At this time, no button is available.
6. Pull out the AC code once, then insert it again.

REMOTE CONTROL KEY CODE

NEC Format

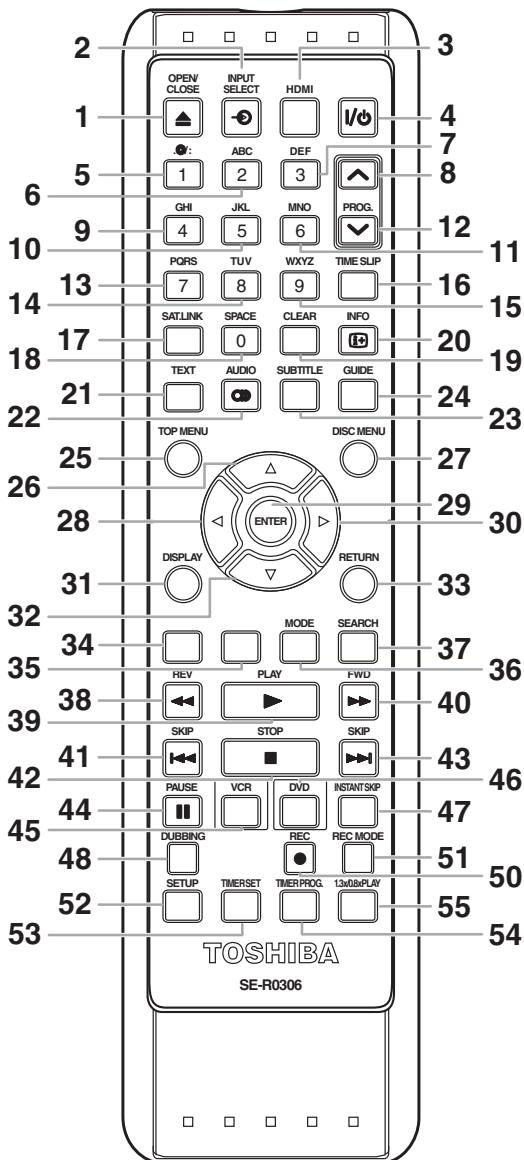

Key No.	Name	Code
1	OPEN/CLOSE	45BC-11
2	INPUT SELECT	45BC-0F
3	HDMI	45BC-B0
4	ON/STANDBY	45BC-12
5	1	45BC-01
6	2	45BC-02
7	3	45BC-03
8	PROG. UP	45BC-1E
9	4	45BC-04
10	5	45BC-05
11	6	45BC-06
12	PROG. DOWN	45BC-1F
13	7	45BC-07
14	8	45BC-08
15	9	45BC-09
16	TIME SLIP	45BC-1A
17	SATLINK	45BC-1D
18	0	45BC-00
19	CLEAR	45BC-53
20	INFO	45BC-3F
21	TEXT	45BC - 23
22	AUDIO	45BC-D3
23	SUBTITLE	45BC-D5
24	GUIDE	45BC-6D
25	TOP MENU	45BC-D0
26	CURSOR UP	45BC-C0
27	DISC MENU	45BC-D1
28	CURSOR LEFT	45BC-CC
29	ENTER	45BC-44
30	CURSOR RIGHT	45BC-C4
31	DISPLAY	45BC-5A
32	CURSOR DOWN	45BC-C8
33	RETURN	45BC-D2
34	RED	45BC-2A
35	GREEN	45BC-2B
36	YELLOW(MODE)	45BC-2C
37	BLUE(SEARCH)	45BC-29
38	REV	45BC-98
39	PLAY	45BC-13
40	FWD	45BC-9A
41	SKIP DOWN	45BC-84
42	STOP	45BC-16
43	SKIP UP	45BC-80
44	PAUSE	45BC-17
45	VCR	45BC-1B
46	DVD	45BC-18
47	INSTANT SKIP	45BC-5B
48	DUBBING	45BC-56
49	---	---
50	REC	45BC-15
51	REC MODE	45BC-A7
52	SETUP	45BC-52
53	TIMER SET	45BC-67
54	TIMER PROG.	45BC-40
55	1.3x/0.8x PLAY	45BC-AA

TROUBLESHOOTING

NOTE: BOARD MEANS PRINTED CIRCUIT BOARD.

1 Power Supply Section

FLOW CHART NO.1

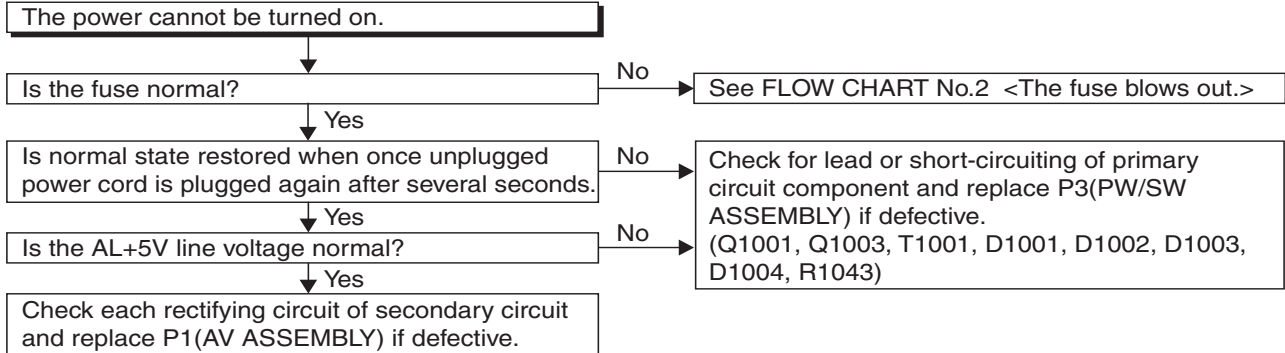

FLOW CHART NO.2

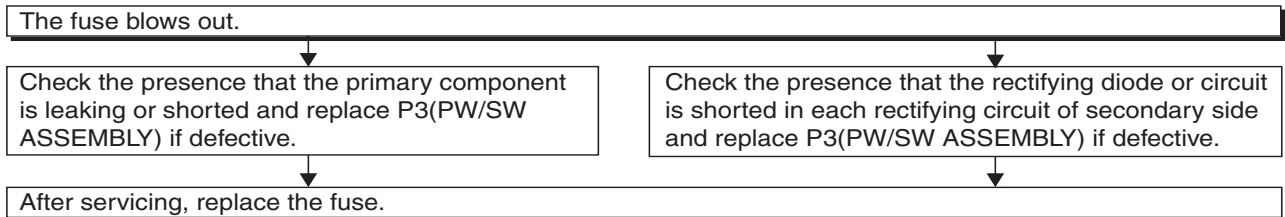

FLOW CHART NO.3

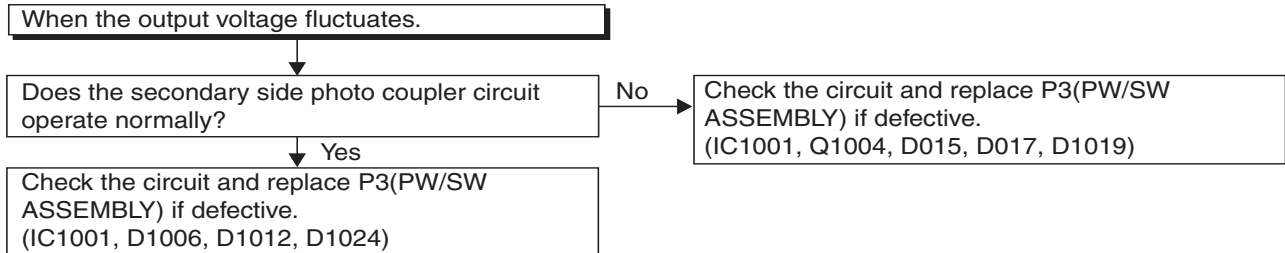

FLOW CHART NO.4

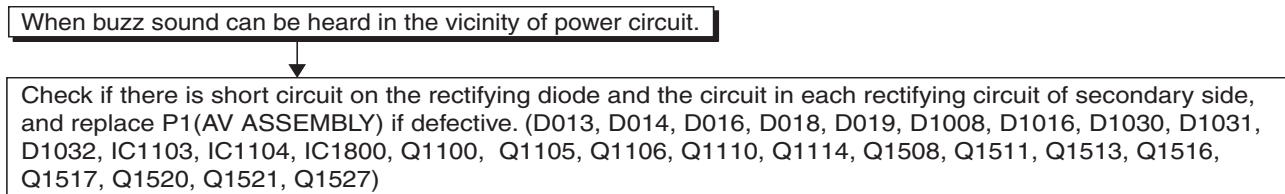

FLOW CHART NO.5

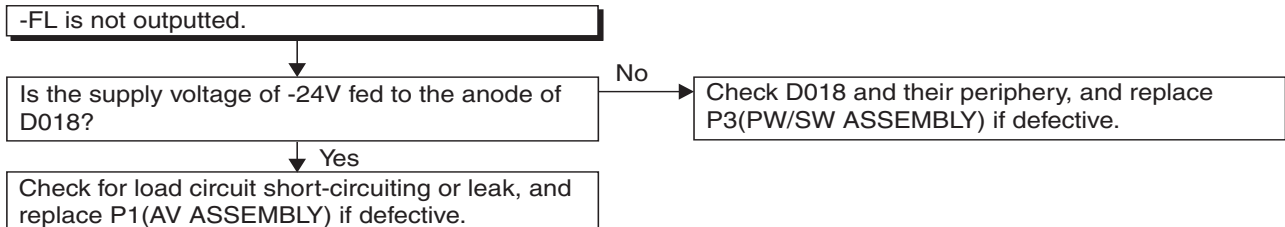

FLOW CHART NO.6

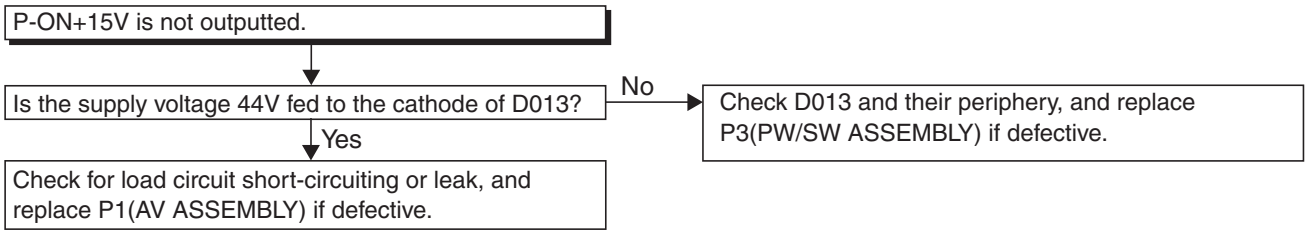

FLOW CHART NO.7

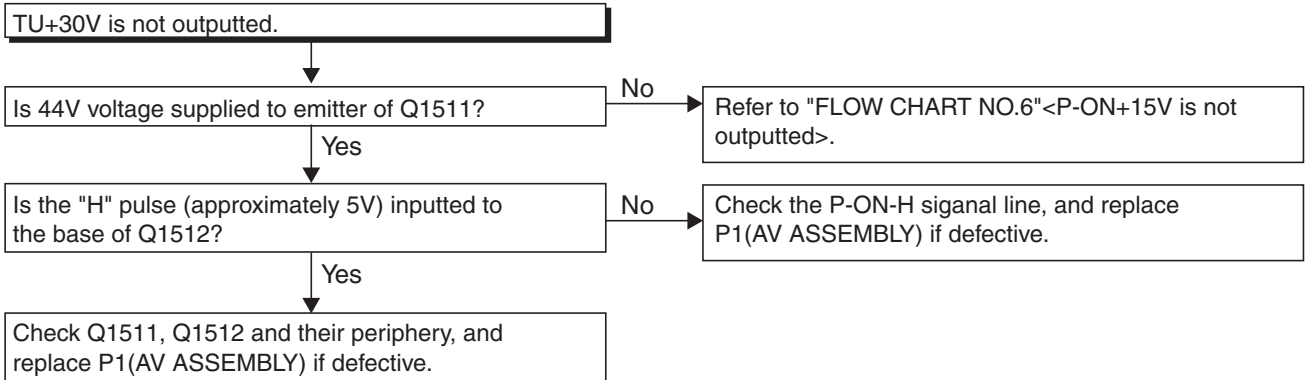

FLOW CHART NO.8

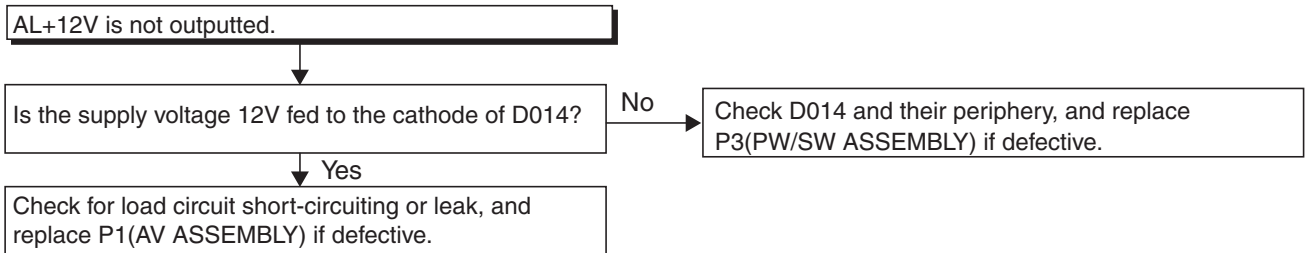

FLOW CHART NO.9

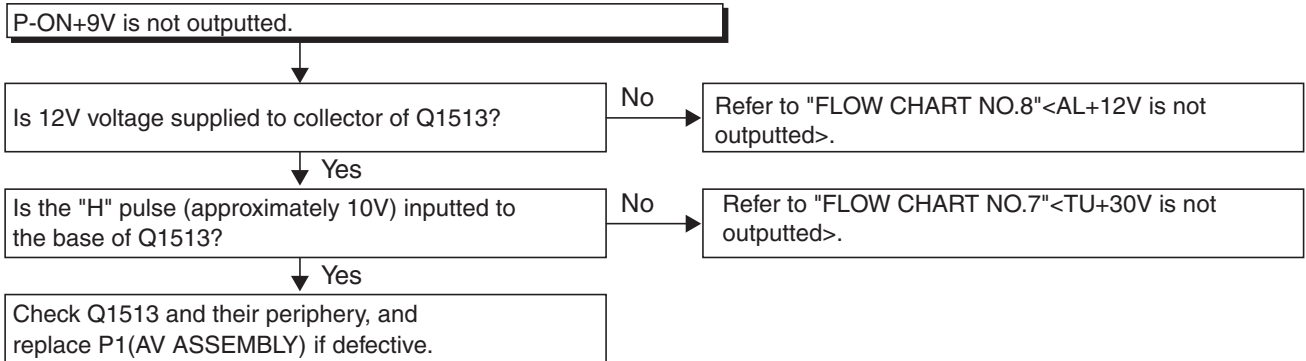

FLOW CHART NO.10

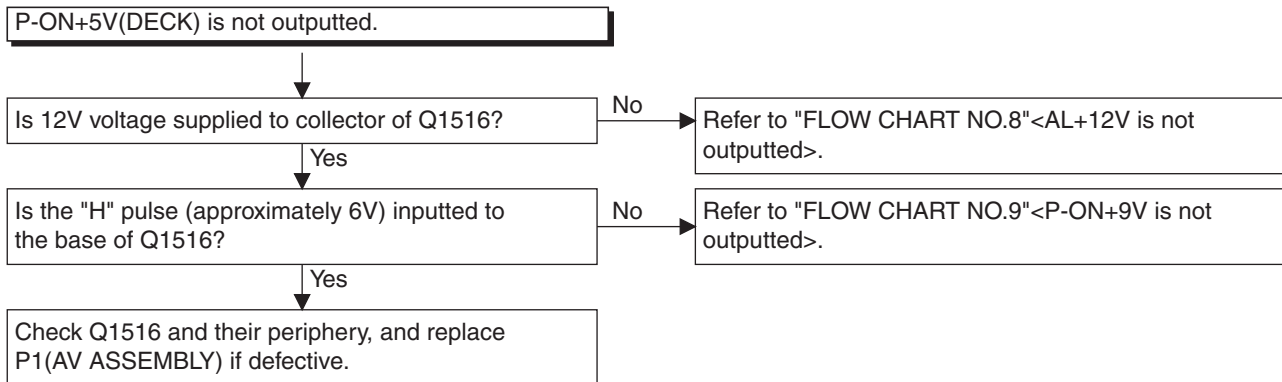

FLOW CHART NO.11

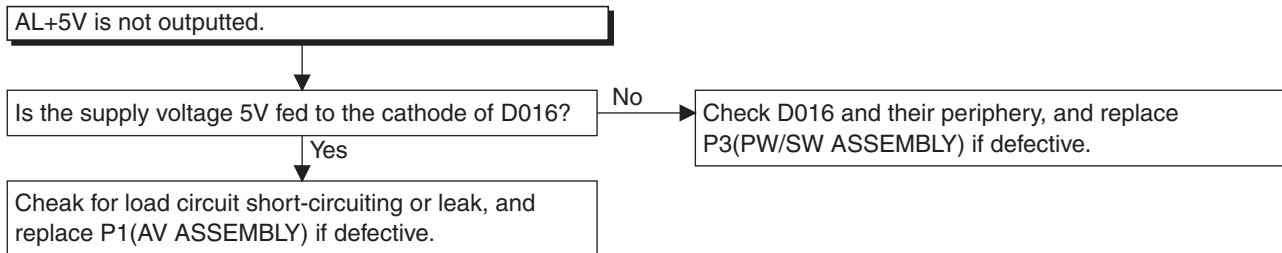

FLOW CHART NO.12

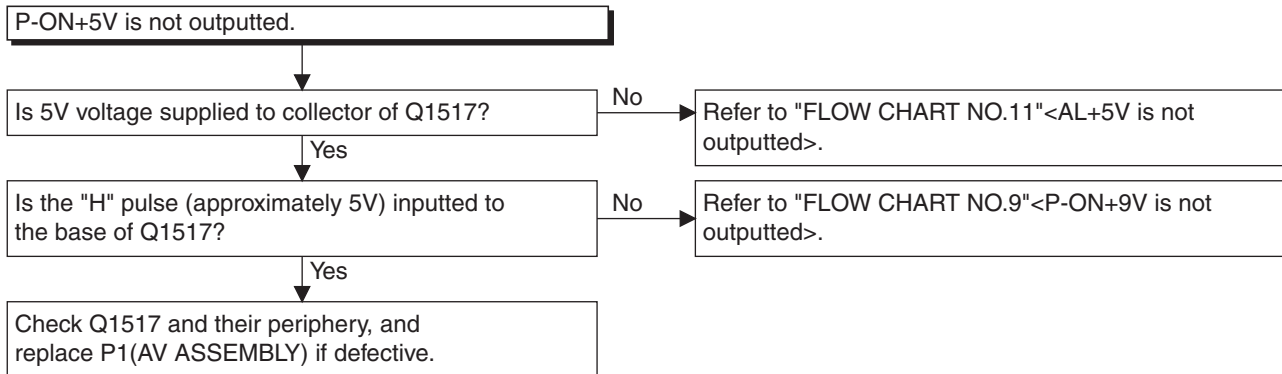

FLOW CHART NO.13

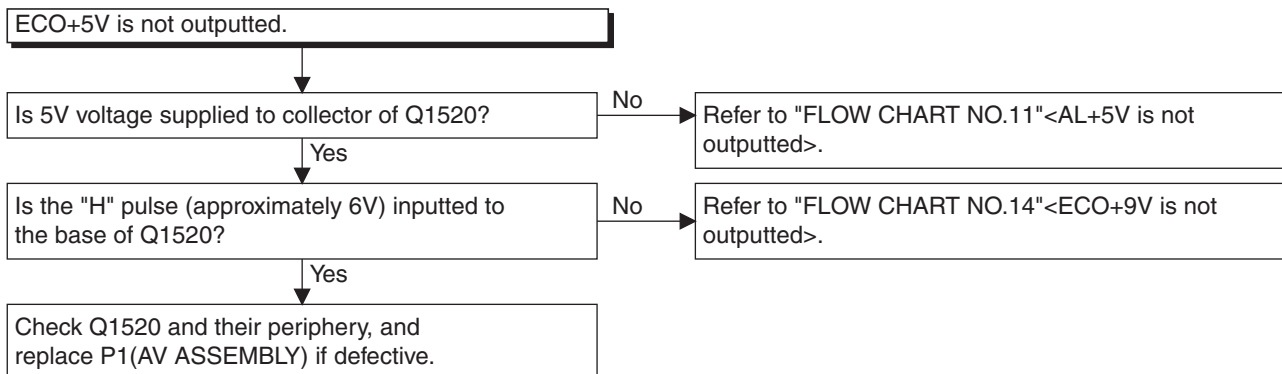

FLOW CHART NO.14

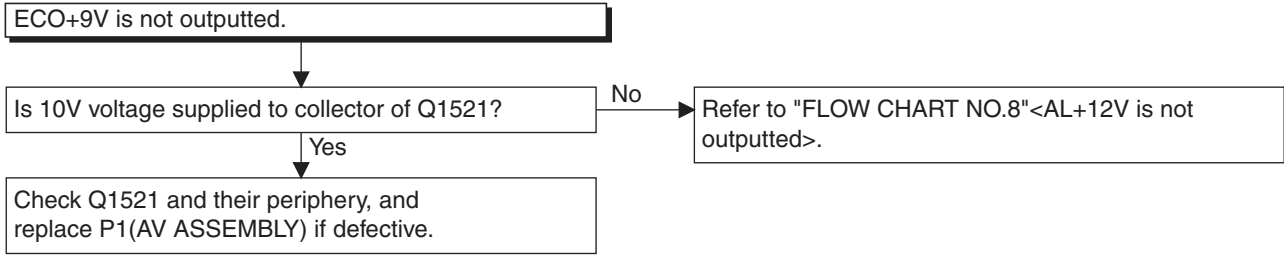

FLOW CHART NO.15

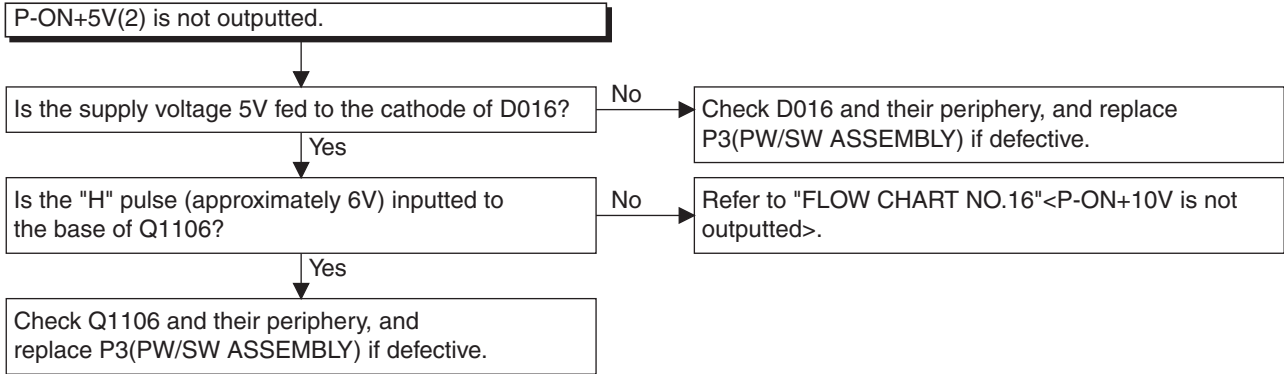

FLOW CHART NO.16

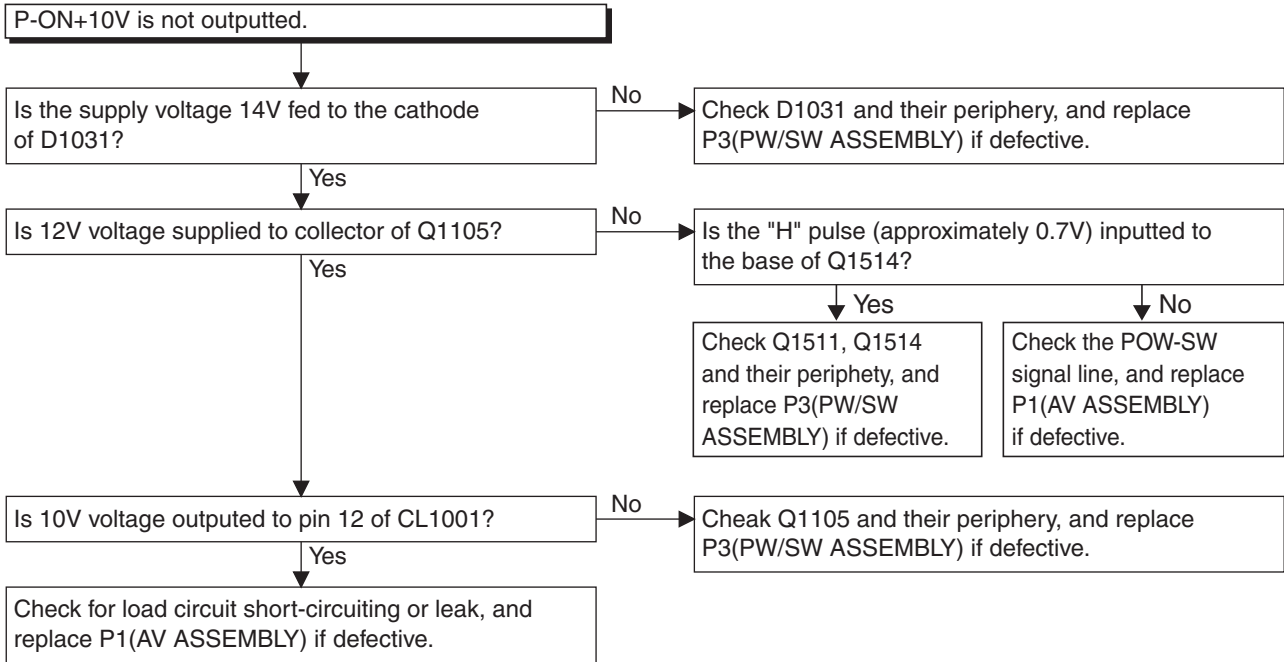

FLOW CHART NO.17

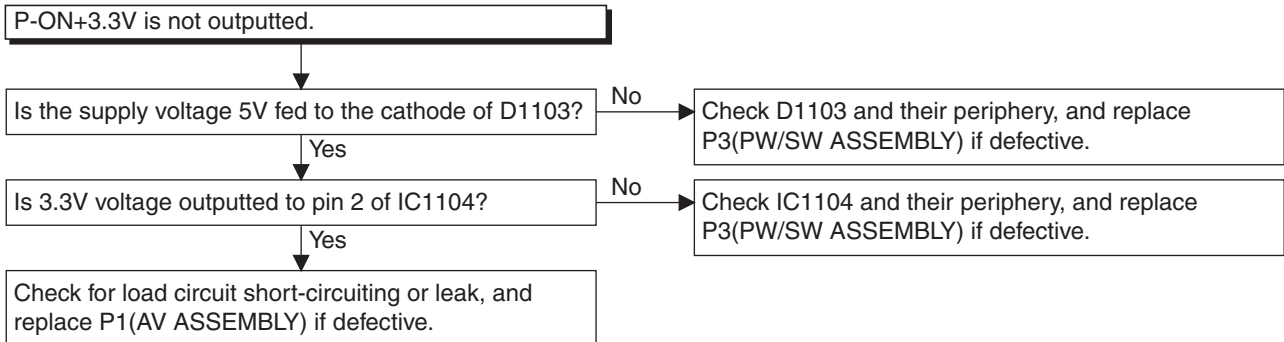

FLOW CHART NO.18

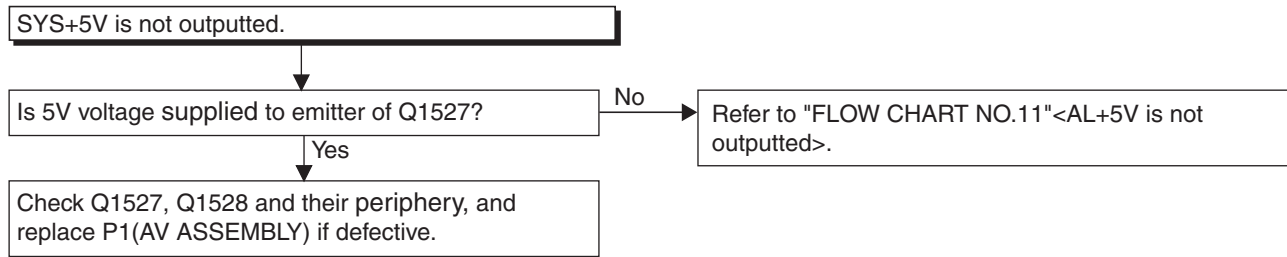

FLOW CHART NO.19

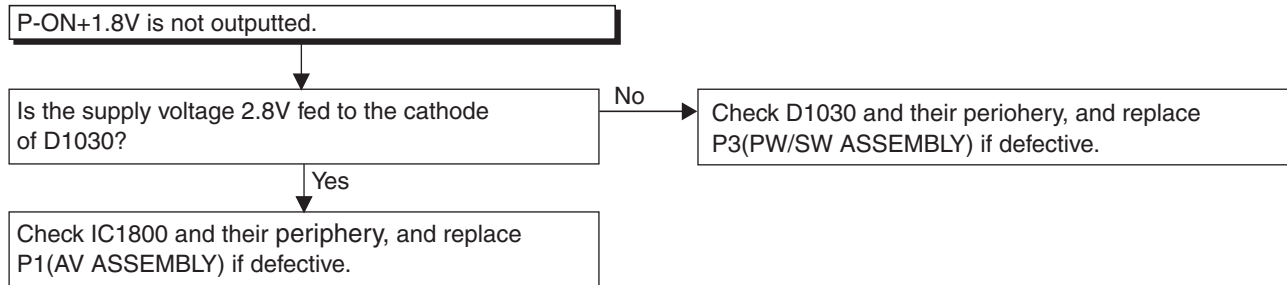

FLOW CHART NO.20

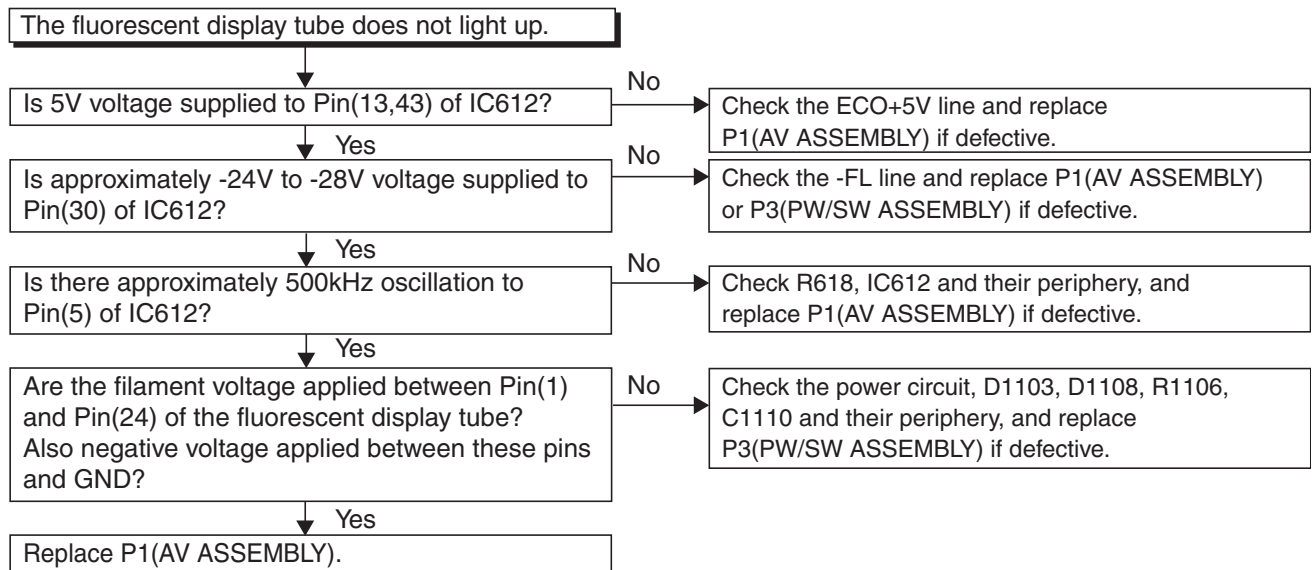

2 DVD Section

FLOW CHART NO.1

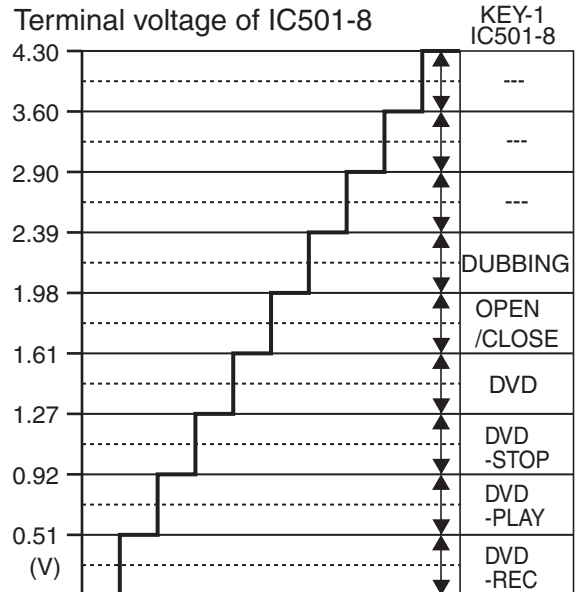
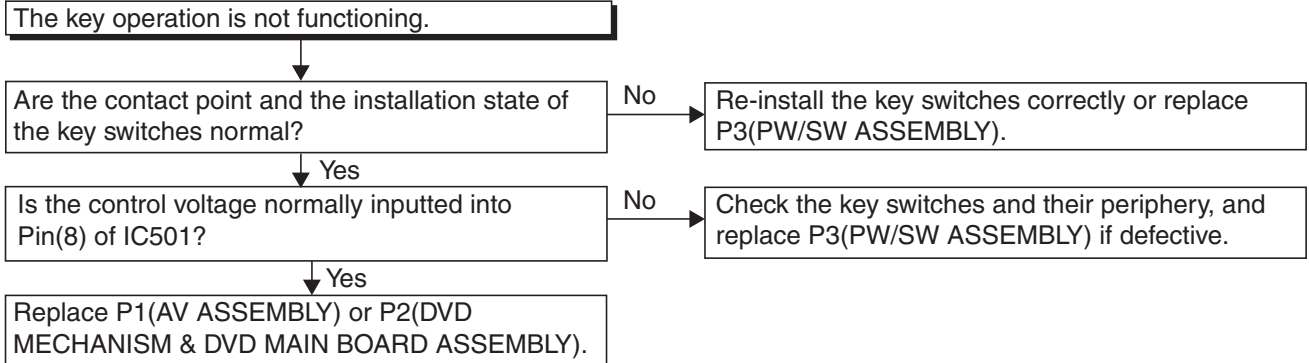

FLOW CHART NO.2

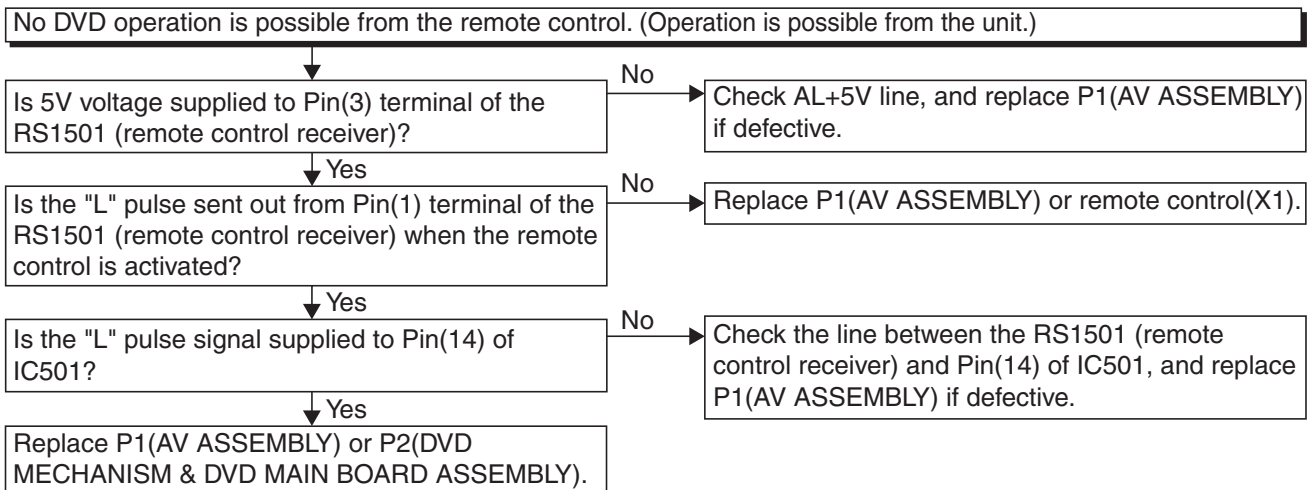

FLOW CHART NO.3

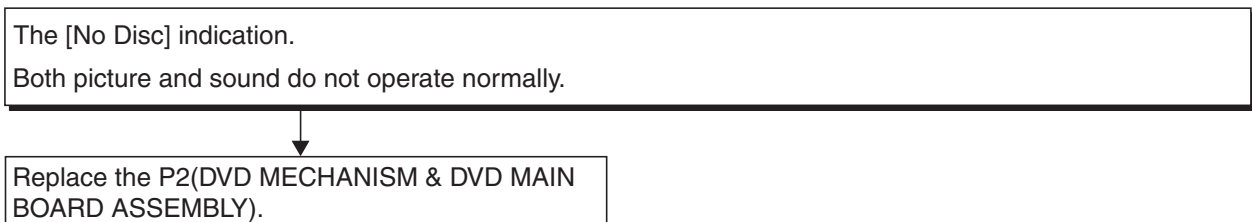

FLOW CHART NO.4

VIDEO E-E does not appear normally.

Are the video signals inputted to each pin of IC1509?

IC1509	18PIN	VIDEO-IN 1 (AV1)
IC1509	14PIN	VIDEO-IN (FRONT)
IC1509	3PIN	DTV-Y
IC1509	5PIN	DTV-C
IC1509	12PIN	VIDEO-IN 2 (AV2)
IC1509	20PIN	TUNER-VIDEO

No → Check the line between video input terminal and each pin of IC1509, and replace P1(AV ASSEMBLY), P5(BOARD DTV MODULE UNIT) or TU1800.

IC1509	18PIN	→ JK1504	VIDEO-IN 1 (AV1)
IC1509	14PIN	→ JK1231	VIDEO-IN (FRONT)
IC1509	3PIN	→ CN1800 26PIN	DTV-Y
IC1509	5PIN	→ CN1800 28PIN	DTV-C
IC1509	12PIN	→ JK2001	VIDEO-IN 2 (AV2)
IC1509	20PIN	→ TU1800 17PIN	TUNER-VIDEO

Yes → Are the video signals outputted to each pin of IC1509?

IC1509	61PIN	VIDEO-Y/CVBS-IN
IC1509	59PIN	VIDEO-C-IN

No → Is 5V voltage supplied to Pin(27,29,47,63) of IC1509?
Is 9V voltage supplied to Pin(75) of IC1509?

Yes → Replace P1(AV ASSEMBLY).
No → Check the ECO+5V, ECO+9V line and replace P1(AV ASSEMBLY) or P3(PW/SW ASSEMBLY) if defective.

Yes → Are the video signals outputted to each pin of CN1502?

CN1502	20PIN	VIDEO-Y/CVBS-IN
CN1502	22PIN	VIDEO-C-IN

No → Check the line between each pin of IC1509 and each pin of CN1502 and replace P1(AV ASSEMBLY) if defective.

IC1509	61PIN	→ CN1502 20PIN	VIDEO-Y/CVBS-IN
IC1509	59PIN	→ CN1502 22PIN	VIDEO-C-IN

Yes → Continued to (A) on the next page.

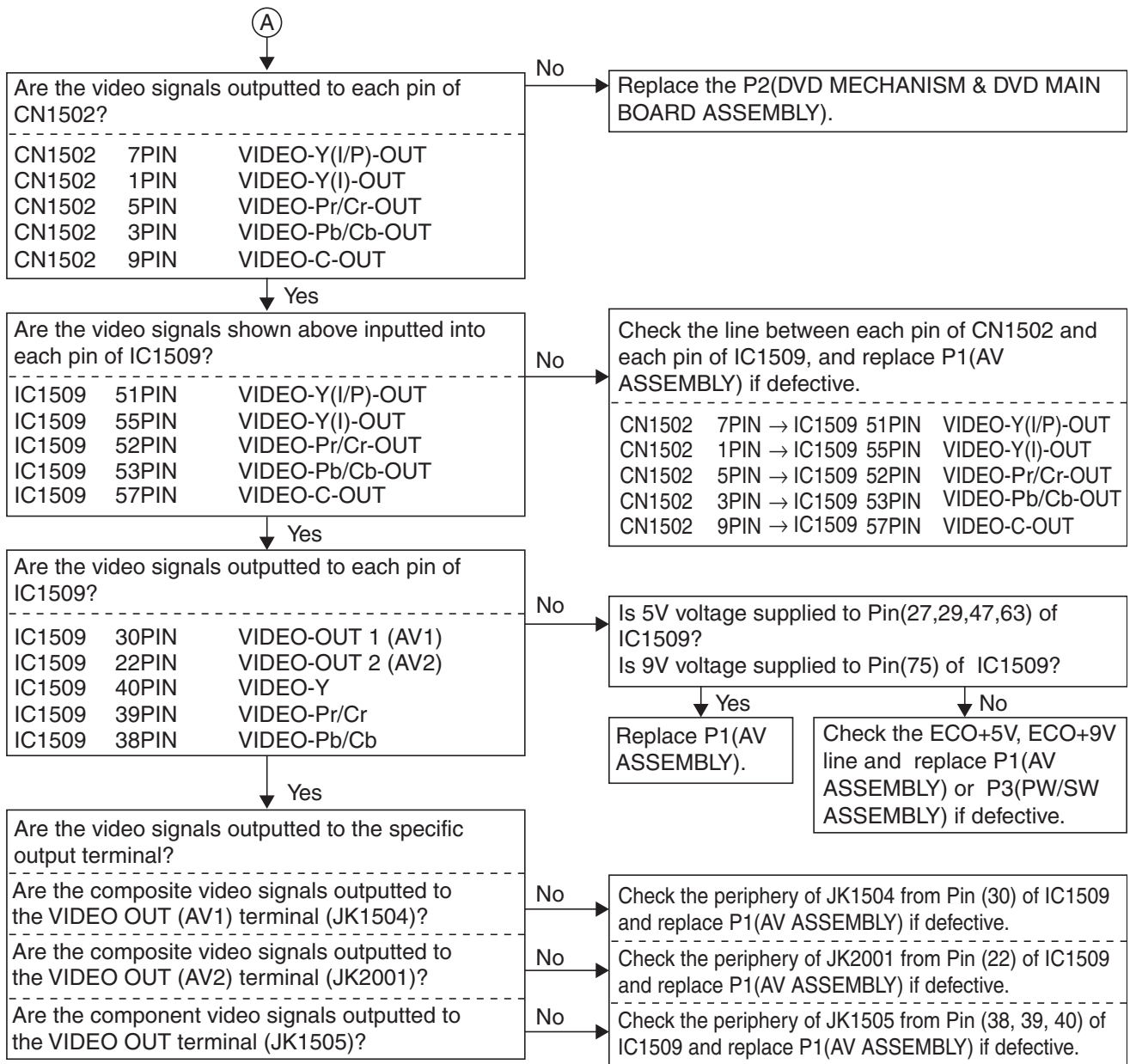

FLOW CHART NO.5

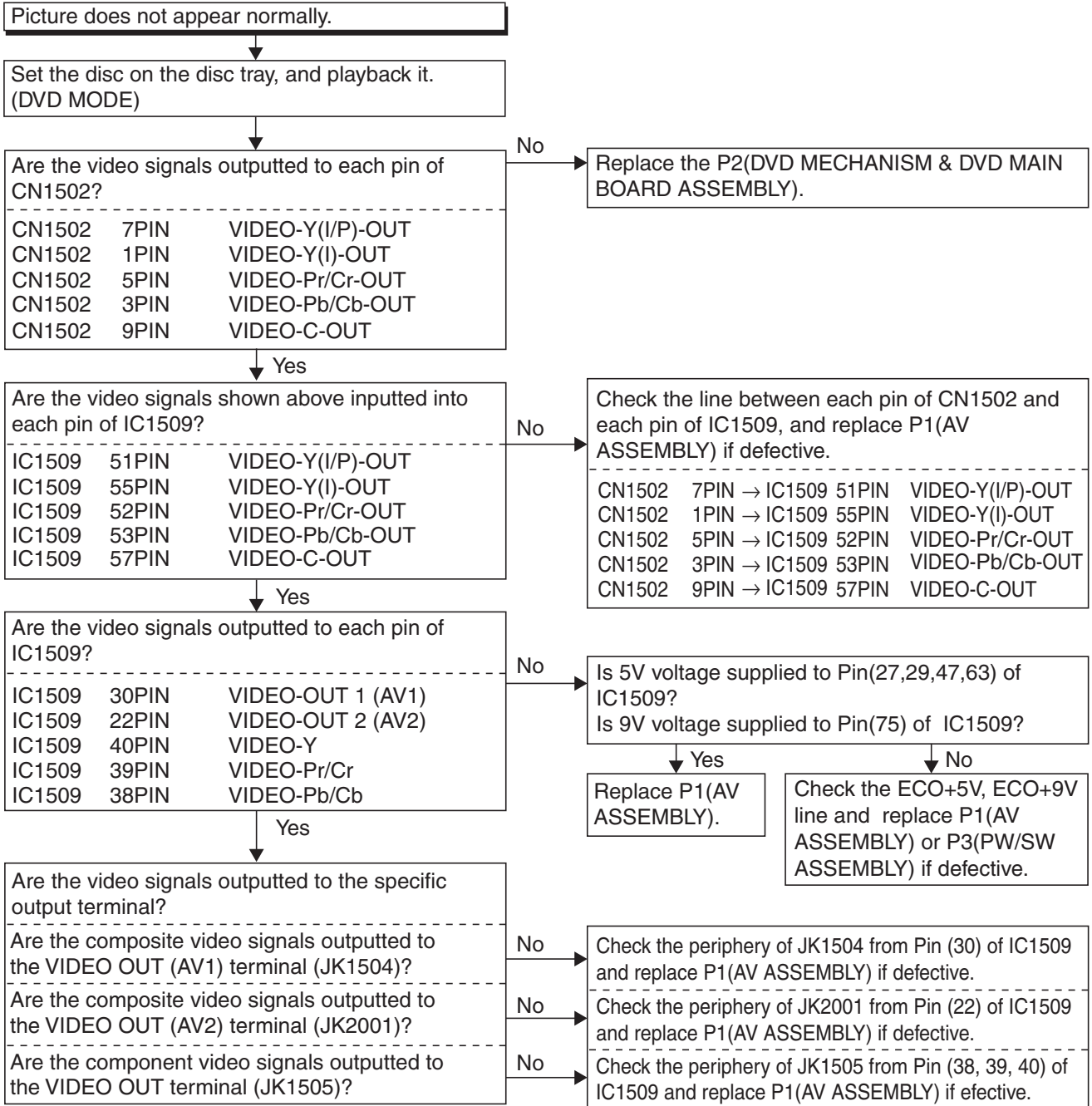

FLOW CHART NO.6

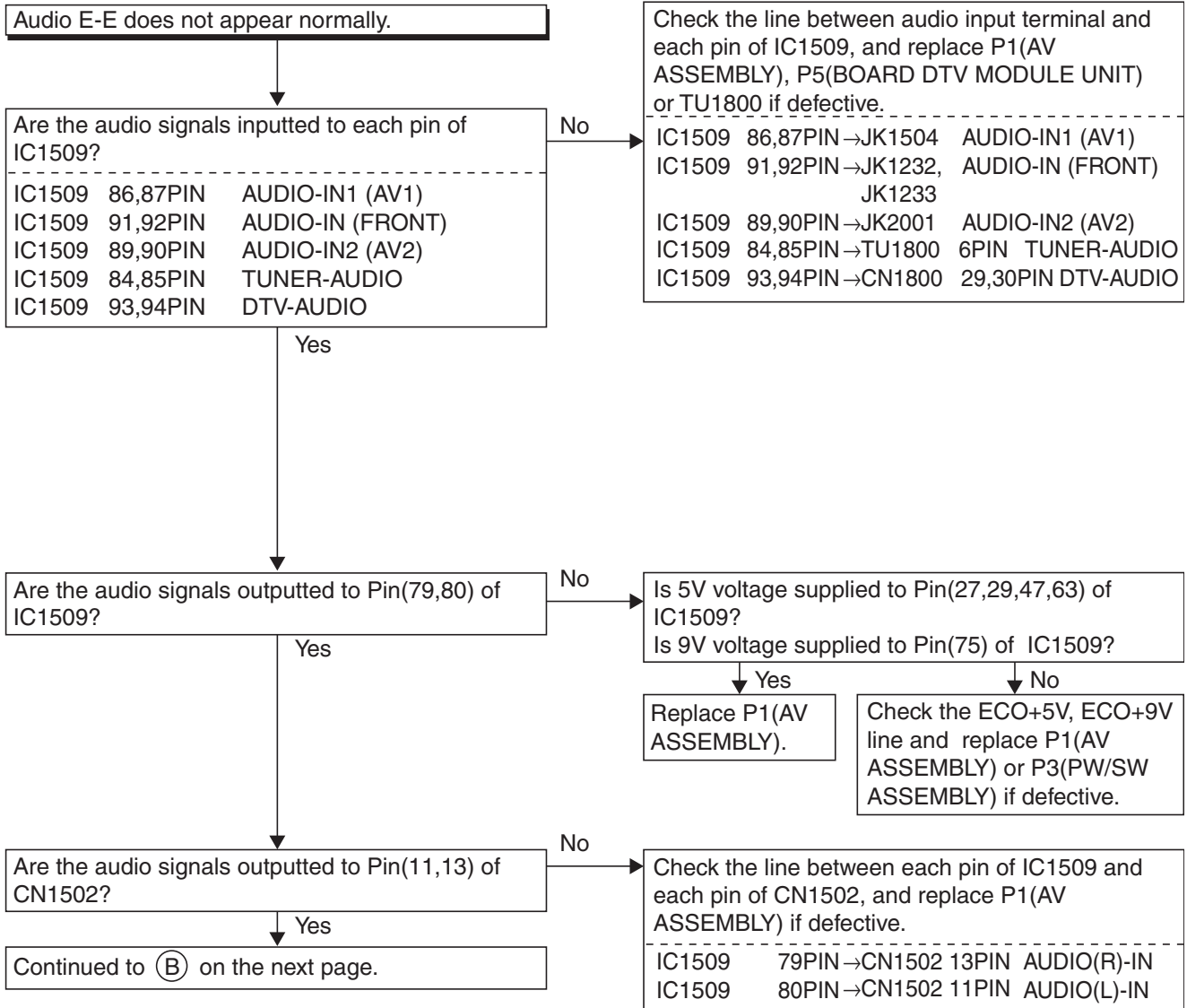

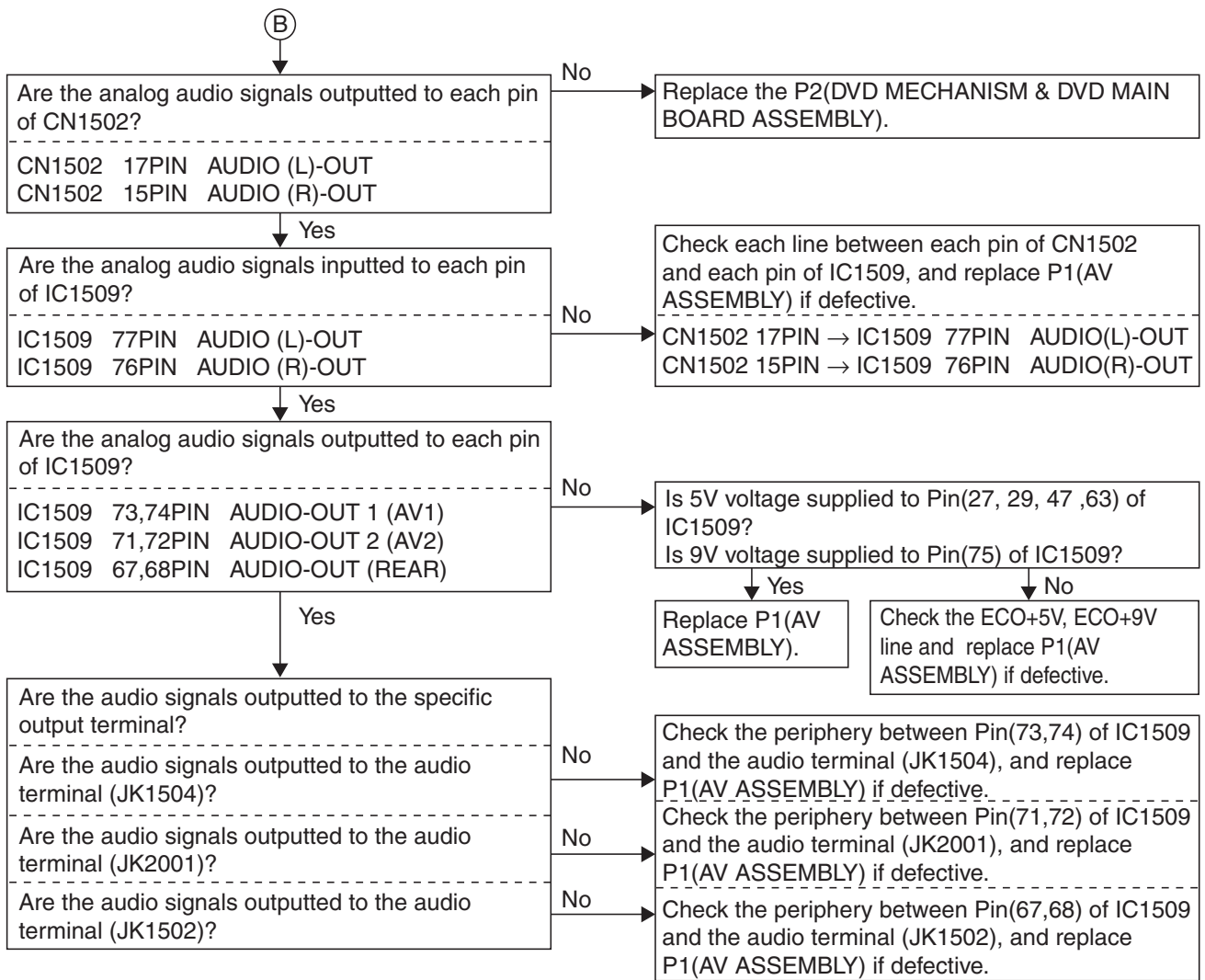

FLOW CHART NO.7

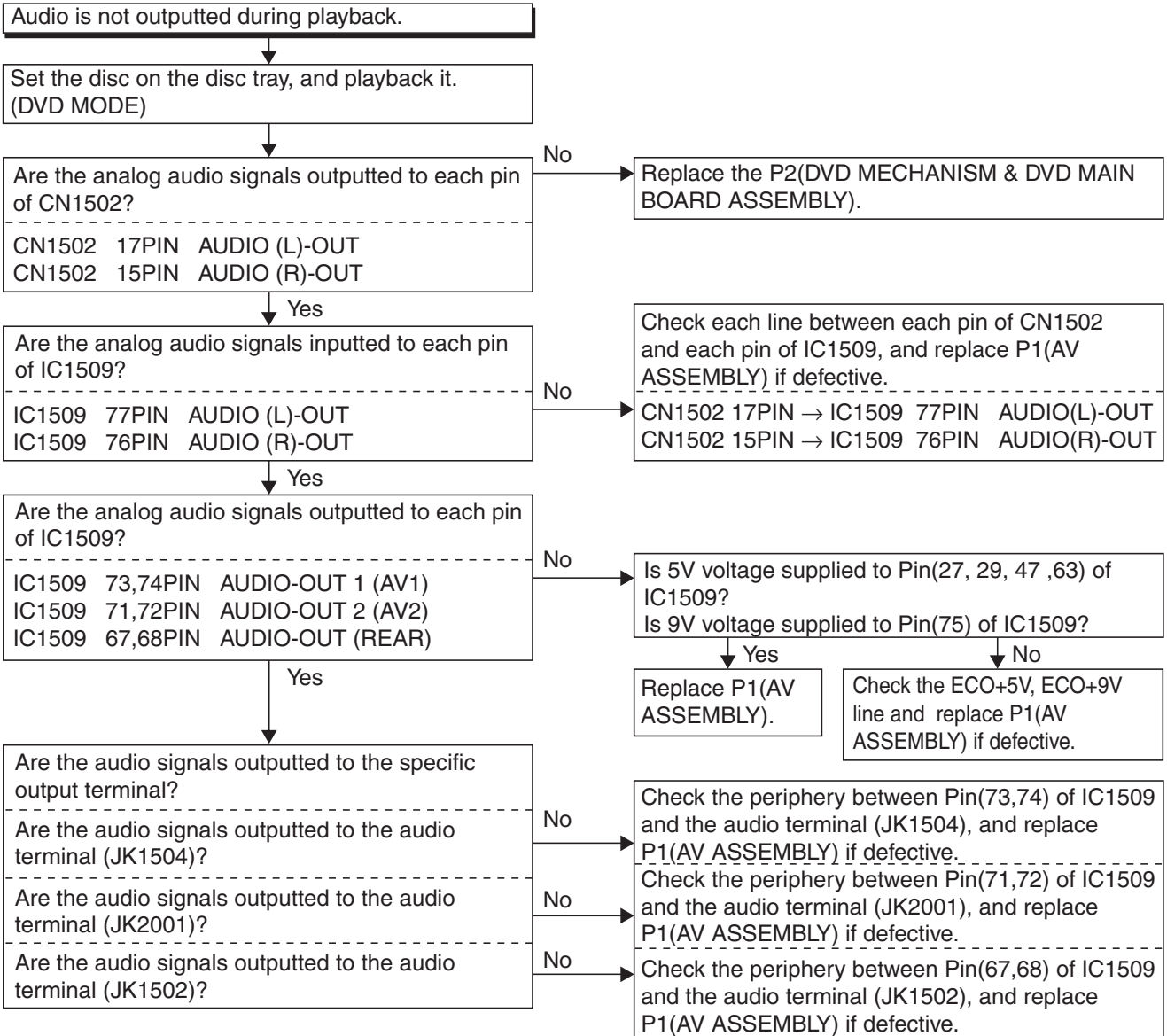

3 VCR Section

FLOW CHART NO.1

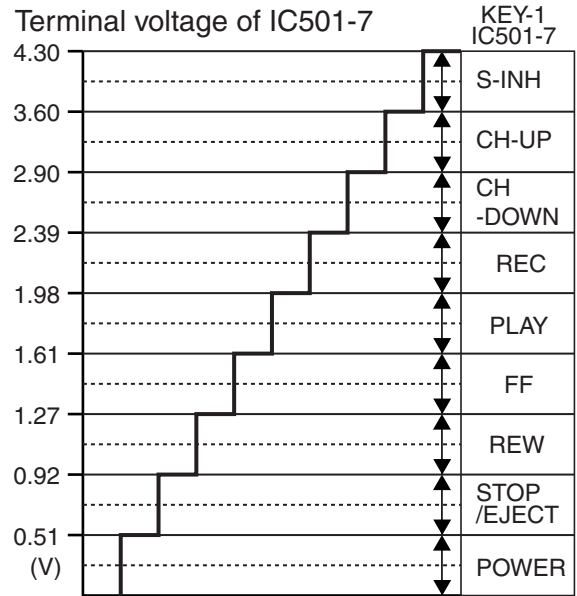
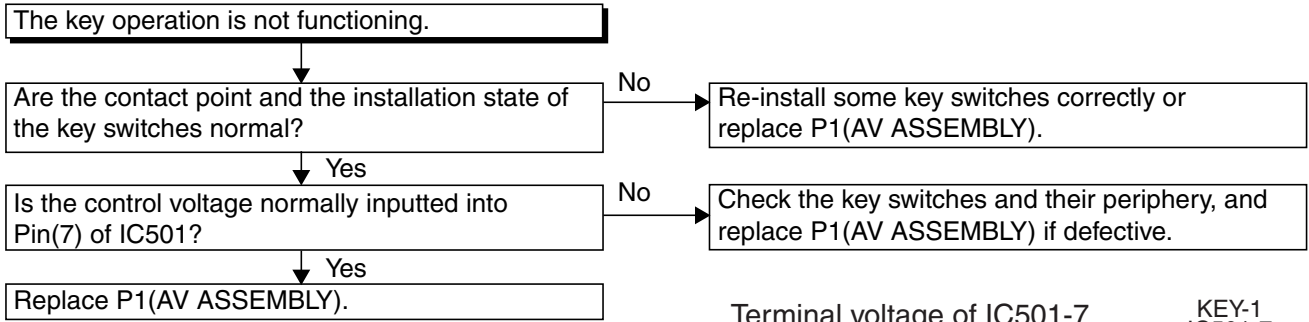

FLOW CHART NO.2

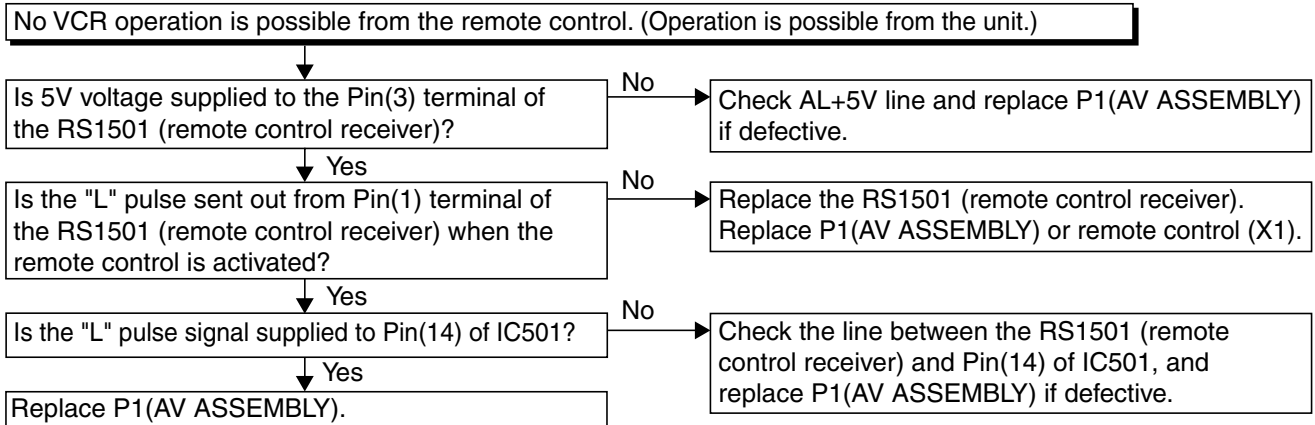

FLOW CHART NO.3

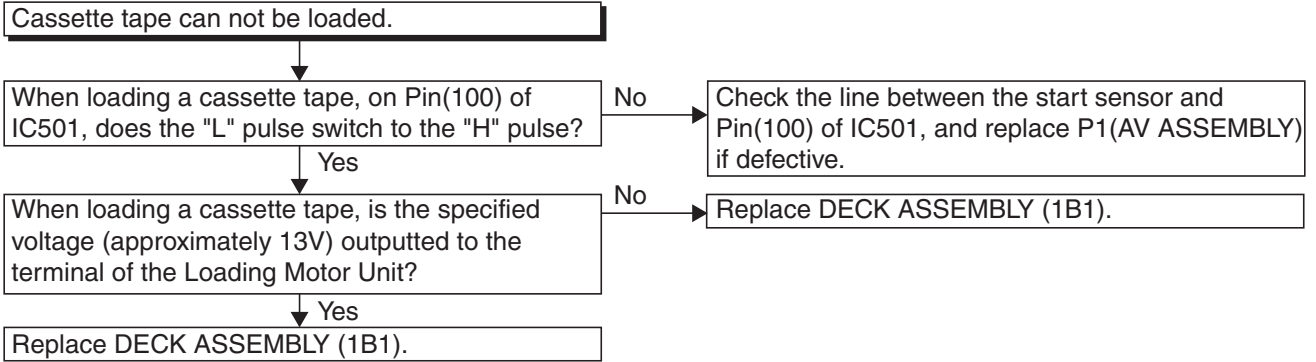

FLOW CHART NO.4

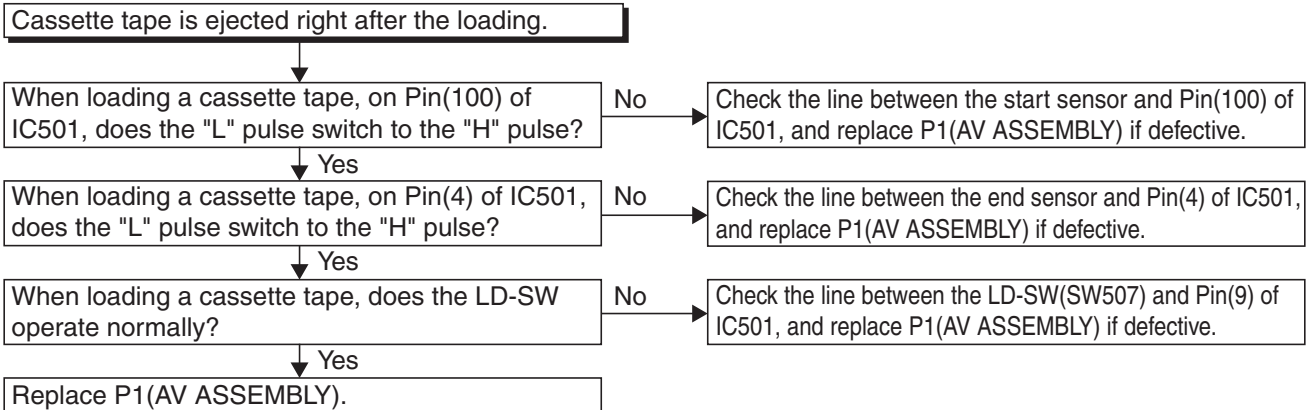

FLOW CHART NO.5

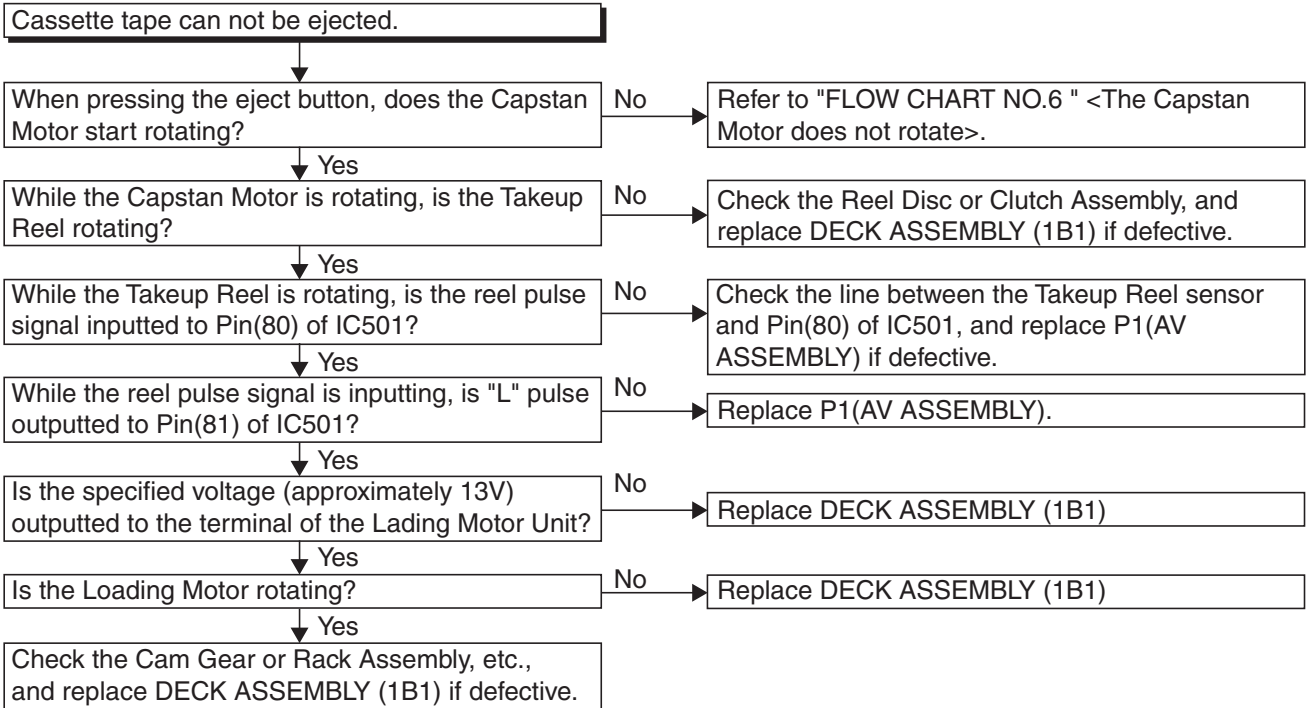

FLOW CHART NO.6

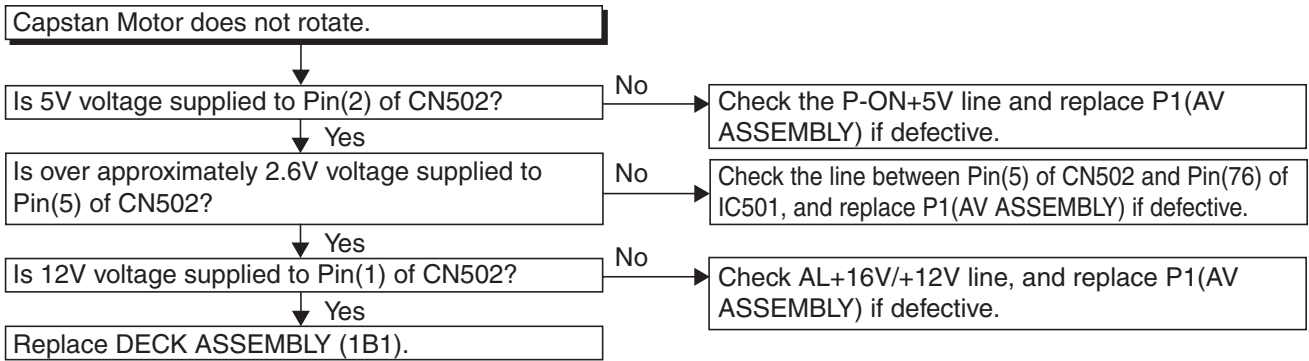

FLOW CHART NO.7

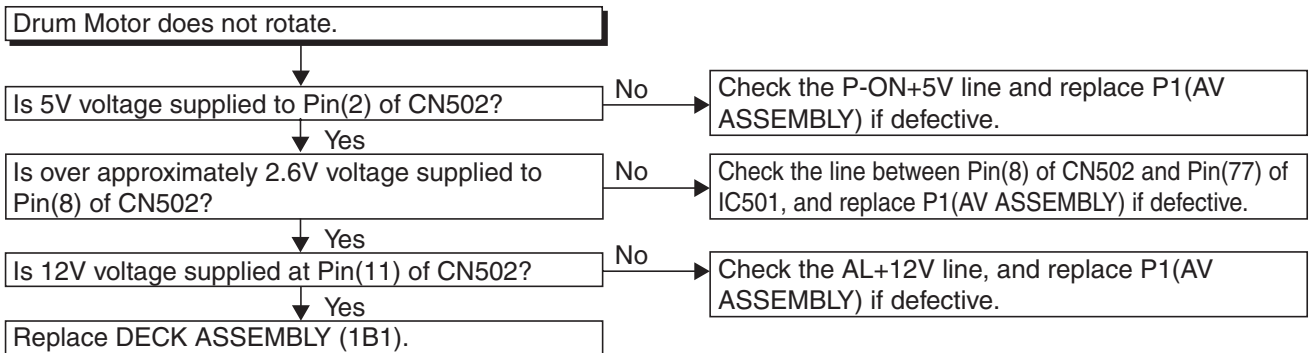

FLOW CHART NO.8

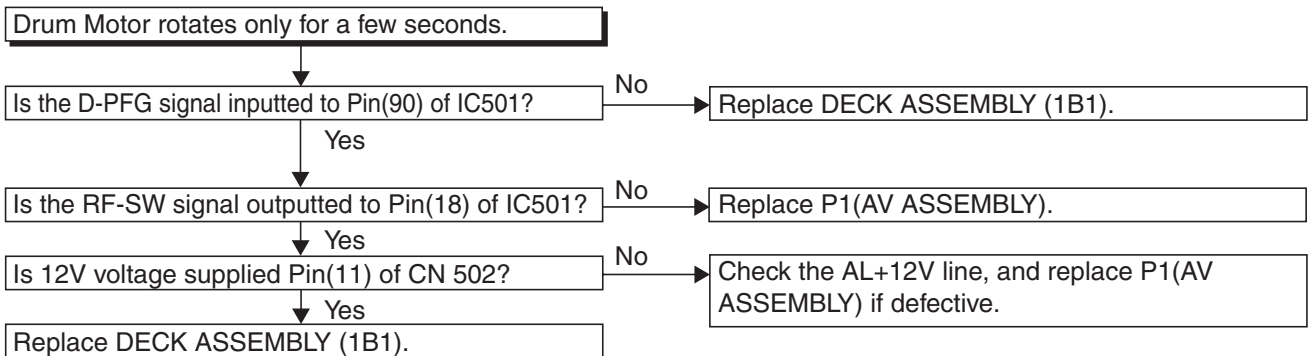

FLOW CHART NO.9

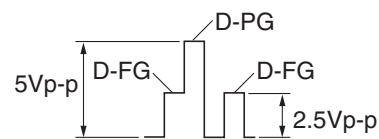
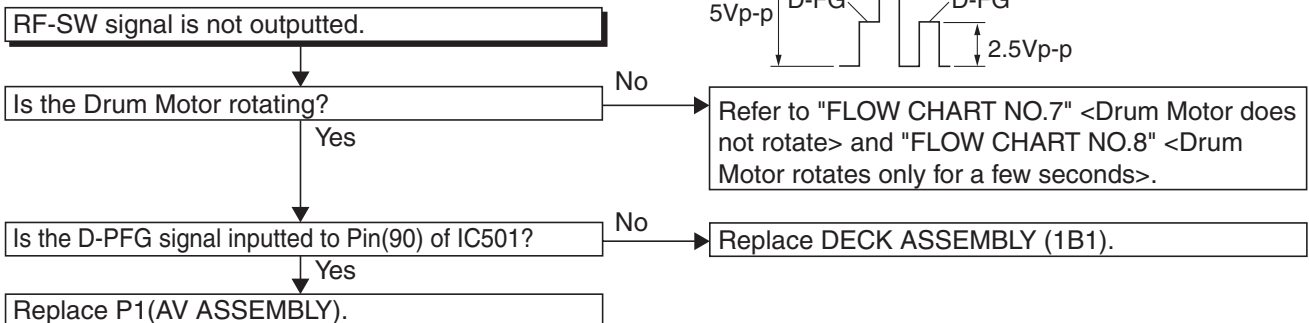

FLOW CHART NO.10

Video E-E does not appear normally.

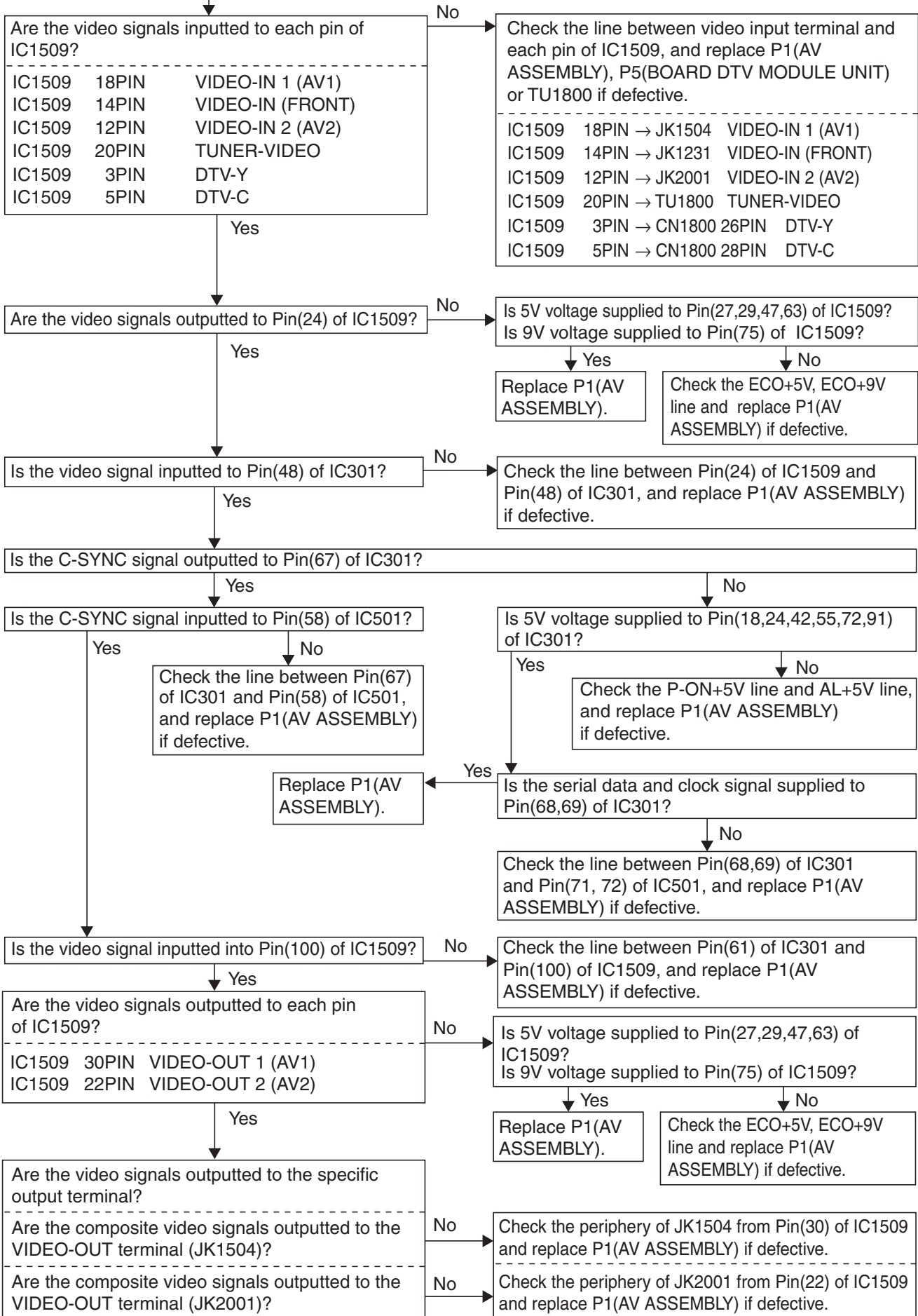

FLOW CHART NO.11

Hi-Fi E-E audio does not operate normally.

Are the audio signals inputted to each pin of IC1509?

IC1509	86,87PIN	AUDIO-IN1 (AV1)
IC1509	91,92PIN	AUDIO-IN (FRONT)
IC1509	89,90PIN	AUDIO-IN2 (AV2)
IC1509	84,85PIN	TUNER-AUDIO
IC1509	93,94PIN	DTV-AUDIO

Check the line between audio input terminal and each pin of IC1509, and replace P1(AV ASSEMBLY), P5(BOARD DTV MODUDLE UNIT) or TU1800 if defective.

IC1509	86,87PIN	→JK1504	AUDIO-IN1 (AV1)
IC1509	91,92PIN	→JK1232,	AUDIO-IN (FRONT)
		JK1233	
IC1509	89,90PIN	→JK2001	AUDIO-IN2 (AV2)
IC1509	84,85PIN	→TU1800	6PIN TUNER-AUDIO
IC1509	93,99PIN	→CN1800	29,30PIN DTV-AUDIO

Are the audio signals outputted to Pin(69,70) of IC1509?

No

Is 5V voltage supplied to Pin(27,29,47,63) of IC1509?
Is 9V voltage supplied to Pin(75) of IC1509?

Yes

Replace P1(AV ASSEMBLY).

No

Check the ECO+5V, ECO+9V line and replace P1(AV ASSEMBLY) if defective.

Is the audio signal inputted to Pin(4,50) of IC451?

No

Check the line between Pin(69,70) of IC1509 and Pin(4,50) of IC451, and replace P1(AV ASSEMBLY) if defective.

Is the 5V voltage supplied to Pin(16,32,35,36,46,55) of IC451, and the 9V voltage supplied to Pin(69) of IC451?

No

Check the circuit of AL+5V, P-ON+5V and P-ON+9V, and replace P1(AV ASSEMBLY) if defective.

Is the serial data and the clock signal supplied to Pin(37,38) of IC451?

No

Check the line between Pin(37,38) of IC451 and Pin(71,72) of IC501, and replace P1(AV ASSEMBLY) if defective.

Is the audio signal outputted to Pin(74,76) of IC451?

No

Replace P1(AV ASSEMBLY).

Is the audio signal inputted into Pin(81,82) of IC1509?

No

Check the line between Pin(74,76) of IC451 and Pin(81,82) of IC1509, and replace P1(AV ASSEMBLY) if defective.

Are the audio signals outputted to each pin of IC1509?

IC1509	73,74PIN	AUDIO-OUT 1 (AV1)
IC1509	71,72PIN	AUDIO-OUT 2 (AV2)

No

Is 5V voltage supplied to Pin(27,29,47,63) of IC1509?
Is 9V voltage supplied to Pin(75) of IC1509?

Yes

Replace P1(AV ASSEMBLY).

No

Check the ECO+5V, ECO+9V line and replace P1(AV ASSEMBLY) if defective.

Are the audio signals outputted to the specific output terminal?

Are the audio signals outputted to the audio terminal (JK1504)?

Are the audio signals outputted to the audio terminal (JK2001)?

No

Check the line between Pin(73,74) of IC1509 and audio terminal (JK1504), and replace P1(AV ASSEMBLY) if defective.

No

Check the line between Pin(71,72) of IC1509 and audio terminal (JK2001), and replace P1(AV ASSEMBLY) if defective.

FLOW CHART NO.12

Hi-Fi audio can not be recorded normally. (E-E mode is normal.)

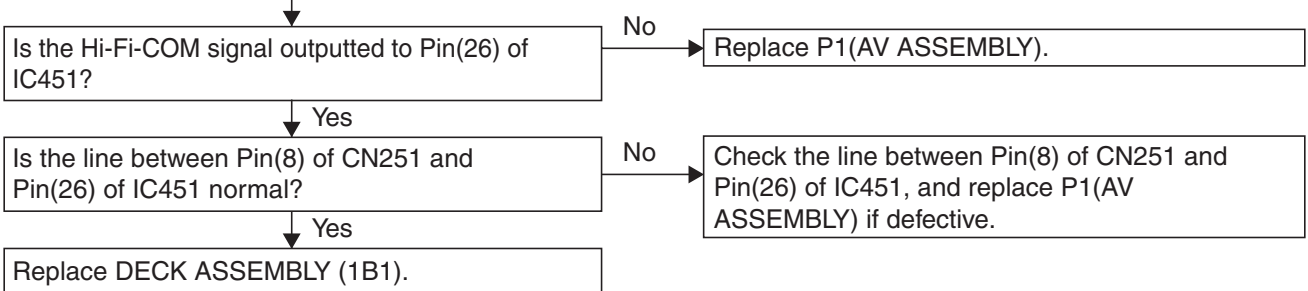

FLOW CHART NO.13

Hi-Fi audio can not be played normally. (Hi-Fi E-E mode is normal.)

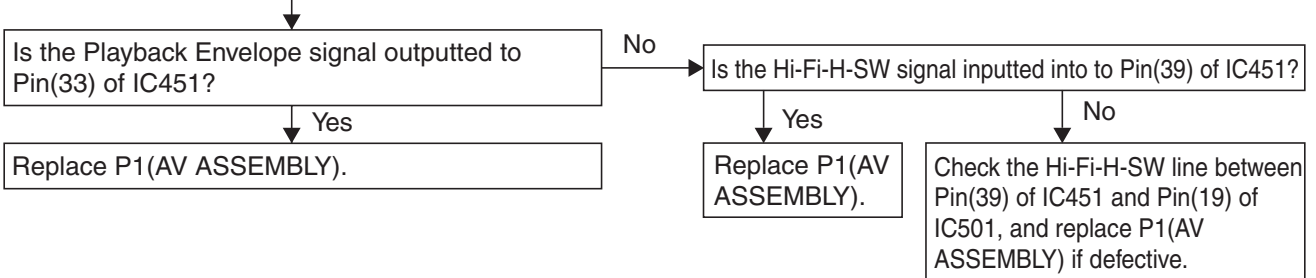

FLOW CHART NO.14

Audio can not be recorded normally in the linear audio mode. (E-E mode is normal.)

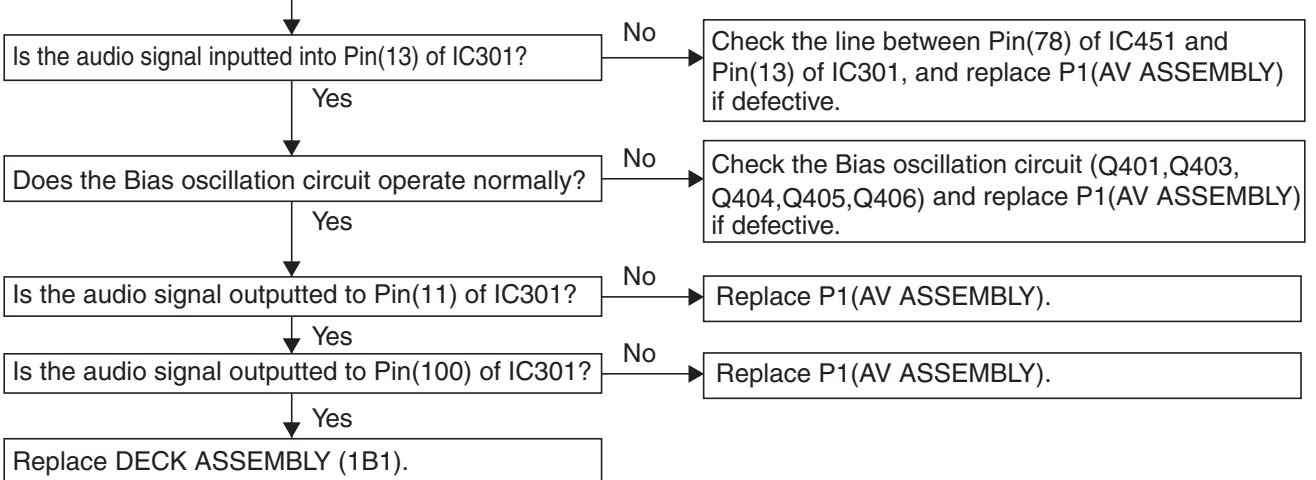

FLOW CHART NO.15

Audio can not be playbacked normally in the linear audio mode. (E-E mode is normal.)

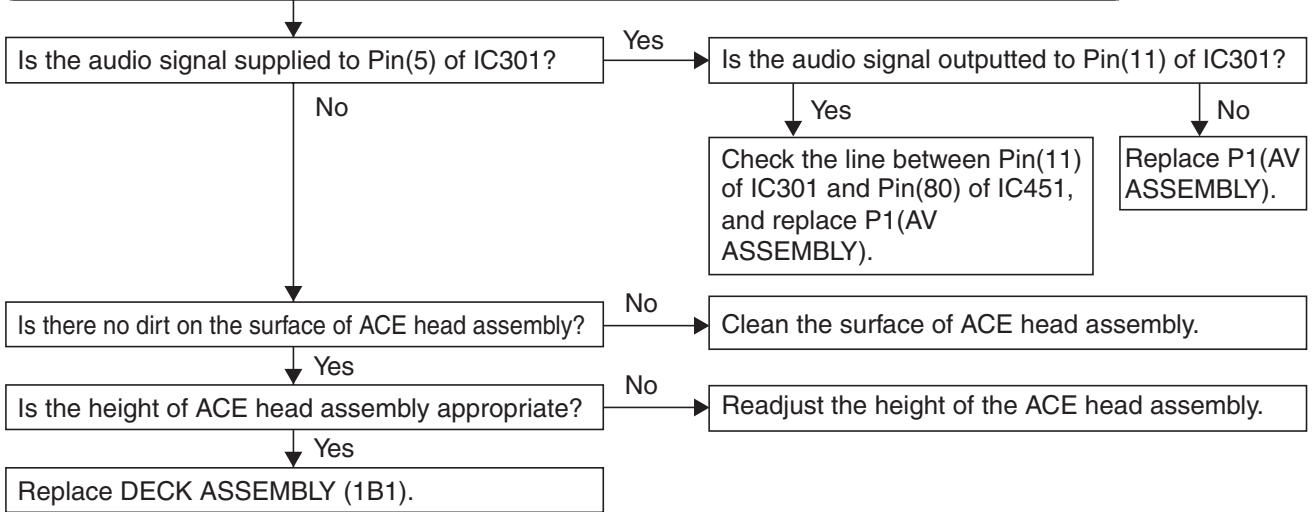

FUNCTION INDICATOR SYMBOLS

< VCR Section >

Note:

If a mechanical malfunction occurs, the power is turned off. When the power comes on again after that by pressing [I/⏪] button, an error message is displayed on the TV screen for 5 seconds.

MODE	INDICATOR ACTIVE
When reel or capstan mechanism is not functioning correctly	"▲ R" is displayed on a TV screen. (Refer to Fig. 1.)
When tape loading mechanism is not functioning correctly	"▲ T" is displayed on a TV screen. (Refer to Fig. 2.)
When cassette loading mechanism is not functioning correctly	"▲ C" is displayed on a TV screen. (Refer to Fig. 3.)
When the drum is not working properly	"▲ D" is displayed on a TV screen. (Refer to Fig. 4.)
P-ON Power safety detection	"▲ P" is displayed on a TV screen. (Refer to Fig. 5.)

TV screen

When reel or capstan mechanism is not functioning correctly

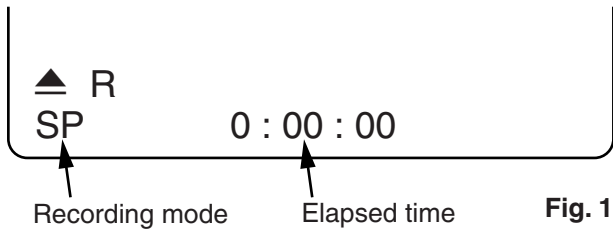

When the drum is not working properly

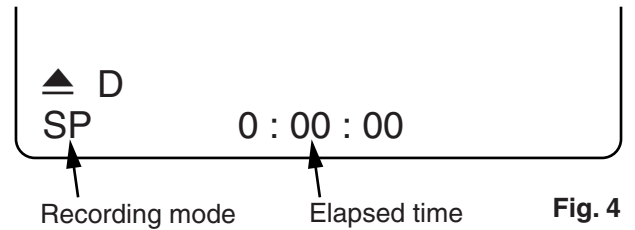

When tape loading mechanism is not functioning correctly

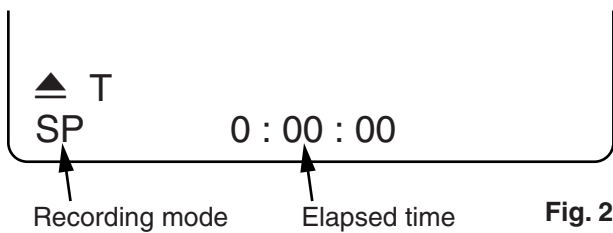

P-ON Power safety detection

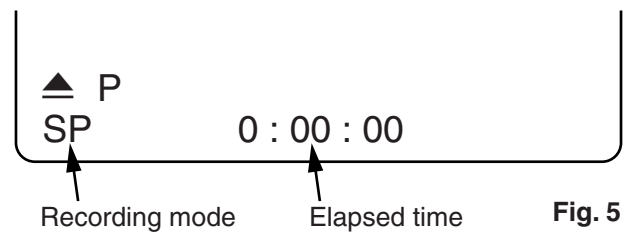

When cassette loading mechanism is not functioning correctly

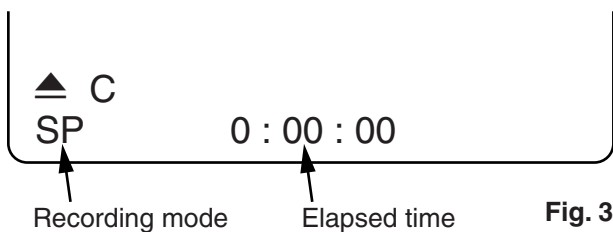

< DVD Section >

Note: If an error occurs, a message with the error number appears on the screen.

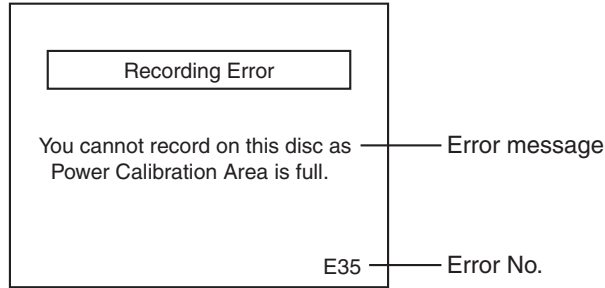

Message	Solution	Error No.	Error Description	Priority
Can not record on this disc.	Insert the recordable disc, and ensure the disc status satisfies the recording requirements.	1	An error occurs during data reading.	-
		2	There is no reply for 15 seconds in Test Unit Ready.	-
		3	Cannot write the data after trying three times.	-
		4	An error occurs with OPC.	-
		5	During recovery in a record.	-
		6	An error occurs even if recovery has been tried three times.	-
		7	An error occurs in a format.	-
		8	It cannot start an encode.	-
		9	NV_PCK/RDI_PCK is not in encoded data.	-
		10	Encode Pause condition continued for 10 minutes.	-
		11	Encode Pause condition continued in normal REC condition for 10 minutes.	-
		12	Difference in the address and can not get Stream ID of RDI/VIDEO.	-
		13	It is a reply that "ATAPI is not readable."	-
		14	Cannot write the data after recovering SMALL VMGI.	-
		15	Cannot write the data after DVD-R Reverse Track.	-
		16	An error occurs in Finalize Close.	-
		17	An error occurs in Rec Stop Close.	-
		18	An error occurs in PCA Full (DVD_R).	-
		19	Safety Stop occurs during editing.	-
		20	High Speed Disc.	2
		21	The disc is not formatted.	5
		22	Disc Error has occurred.	3
		23	The -R Disc of VR Mode.	6
		24	The disc except for finalized DVD-R/RW/+R/+RW.	1
This program is not allowed to be recorded.	You cannot record copy prohibited programs.	25	During the Macrovision picture input.	11
		26	During the CGMS picture input.	12
This program is not recordable in Video mode.	Set "DVD-RW Recording Format" to "VR mode".	27	During the CGMS picture (possible to record once) input. (Video Format Disc)	12
This program is not allowed to be recorded on this disc.	Insert a ver.1.1 CPRM compatible DVD-RW disc.	28	During the CGMS picture (possible to record once) input. (Disc which is not for the correspondence to VR Format CPRM)	12

Message	Solution	Error No.	Error Description	Priority
This disc is protected and not recordable.	Release the disc protect setting in the Disc Setting menu.	29	Disc Protected Disc.	7
Disc is full. (No area for new recording)	Insert the recordable disc with enough recording space.	30	No available recording space.	5
You cannot record more than 99 titles on one disc. (The maximum is 99.)	Delete unnecessary titles.	31	Its recording capacity has been reached. (Video Format Disc)	7
		32	Its recording capacity has been reached. (VR Format Disc)	8
You cannot record more than 999 chapters on one disc. (The maximum is 999.)	Delete unnecessary chapter markers.	33	The 999 chapter has been reached. (VR Format Disc)	9
You cannot record on this disc as Control Information is full.	Delete unnecessary titles.	34	There is not space to record field of control information.	10
You cannot record on the disc as Power Calibration Area is full.	Insert a new disc.	35	PCA is Full. (in REC start)	4
This disc is already finalized.	Release the finalizing for this disc.	36	It is finalized. (Video Format Disc)	6
Can not record on this disc.	Repeat the same operation.	37	Access to Memory Area range outside.	-
		38	Sector Address is wrong.	-
		39	BUP writing error of chapter editing.	-
You cannot record more than 49 titles on one disc. (The maximum is 49.)	Delete unnecessary titles.	43	The 49 titles has been reached. (+VR Format)	9
You cannot record more than 254 chapters on one disc. (The maximum is 254.)	Delete unnecessary chapter marks.	44	The 254 chapter has been reached. (+VR Format Disc)	10
This program is not recordable in +VR mode.	Set "DVD-RW Recording Format" to "VR mode".	45	During the CGMS picture (possible to record once) input. (+VR Format Disc)	12
The disc has no recording compatibility. (Set "Make Recording Compatible" to "ON" to convert the disk.)	Please make the "Make Recording Compatible" setting "ON" when you want to add a postscript.	46	A postscript tried to be added to + VR Format Disc where different Title Menu from this machine when the Make Recording Compatible setting was turned off was recorded.	7

If an error occurs during the timer recording, one of the following error numbers (40 to 42) or the above error messages (error number: 1 to 39 and 43 to 46) is displayed on the recording menu after timer recording. (Once the screen of the program line is exited, the program line for the error will be cleared.) (No Error Message is displayed for the error No. 40 ~ 42.)

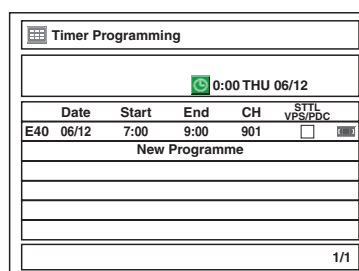

The error program will be displayed in gray with an error number.

Message	Solution	Error No.	Error Description	Priority
Error message is not displayed.	- Set the timer programming correctly. - Set the timer programming before the start time. - Insert a recordable videotape with a record tab.	40	- Some portion has not been recorded because of program overlapping. - Recording did not start at the start time. - No Videotape is inserted. Videotape ran out during recording.	-
	Turn the power on and set the clock correctly then set timer programming again.	41	Power failed	-
	Insert the recordable disc.	42	No disc when recording	-

BLOCK DIAGRAMS

Servo/System Control Block Diagram

NOTE: BOARD MEANS PRINTED CIRCUIT BOARD.

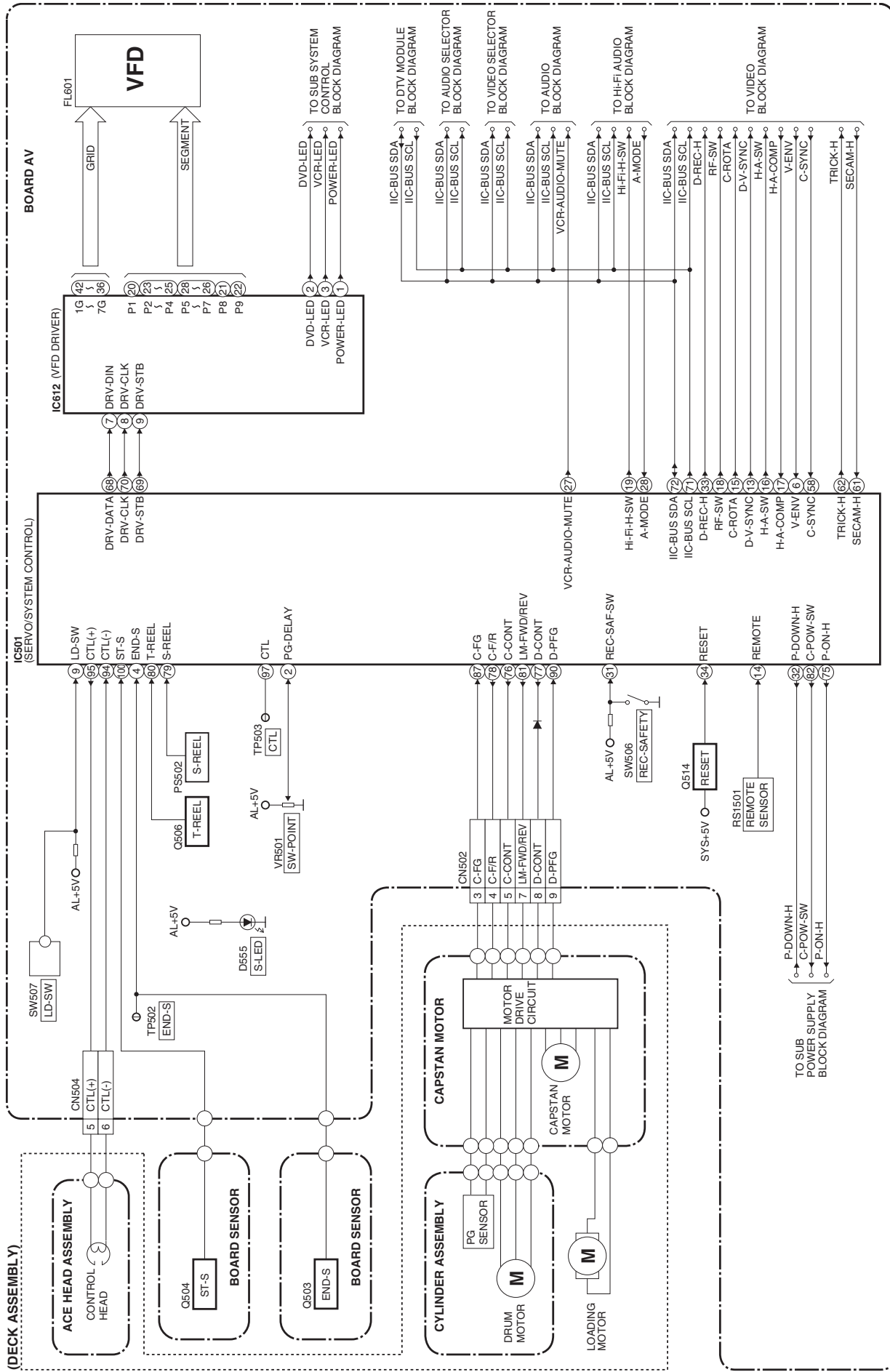

Sub System Control Block Diagram

NOTE: BOARD MEANS PRINTED CIRCUIT BOARD.

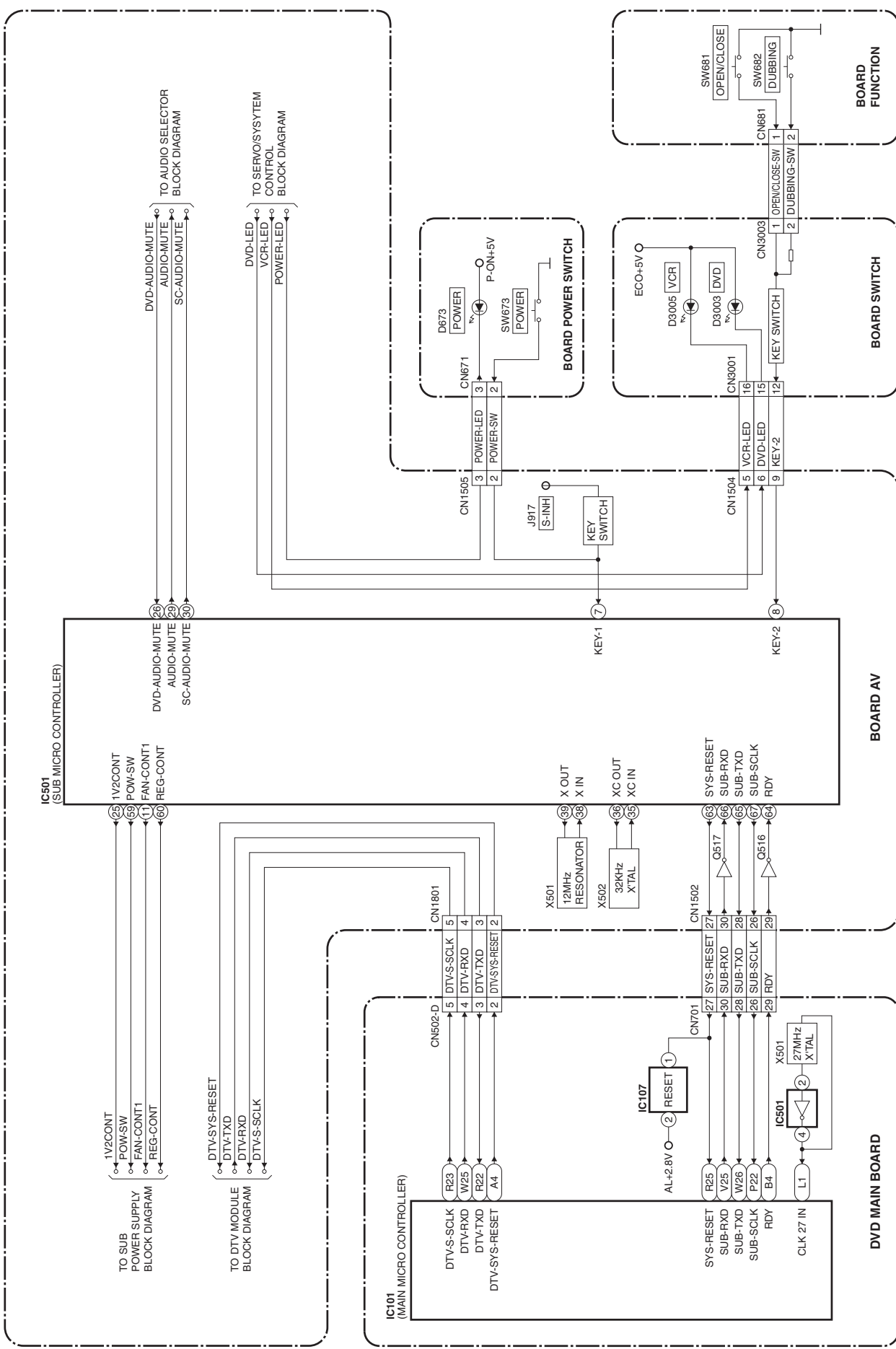

Digital Signal Process Block Diagram

NOTE: BOARD MEANS PRINTED CIRCUIT BOARD.

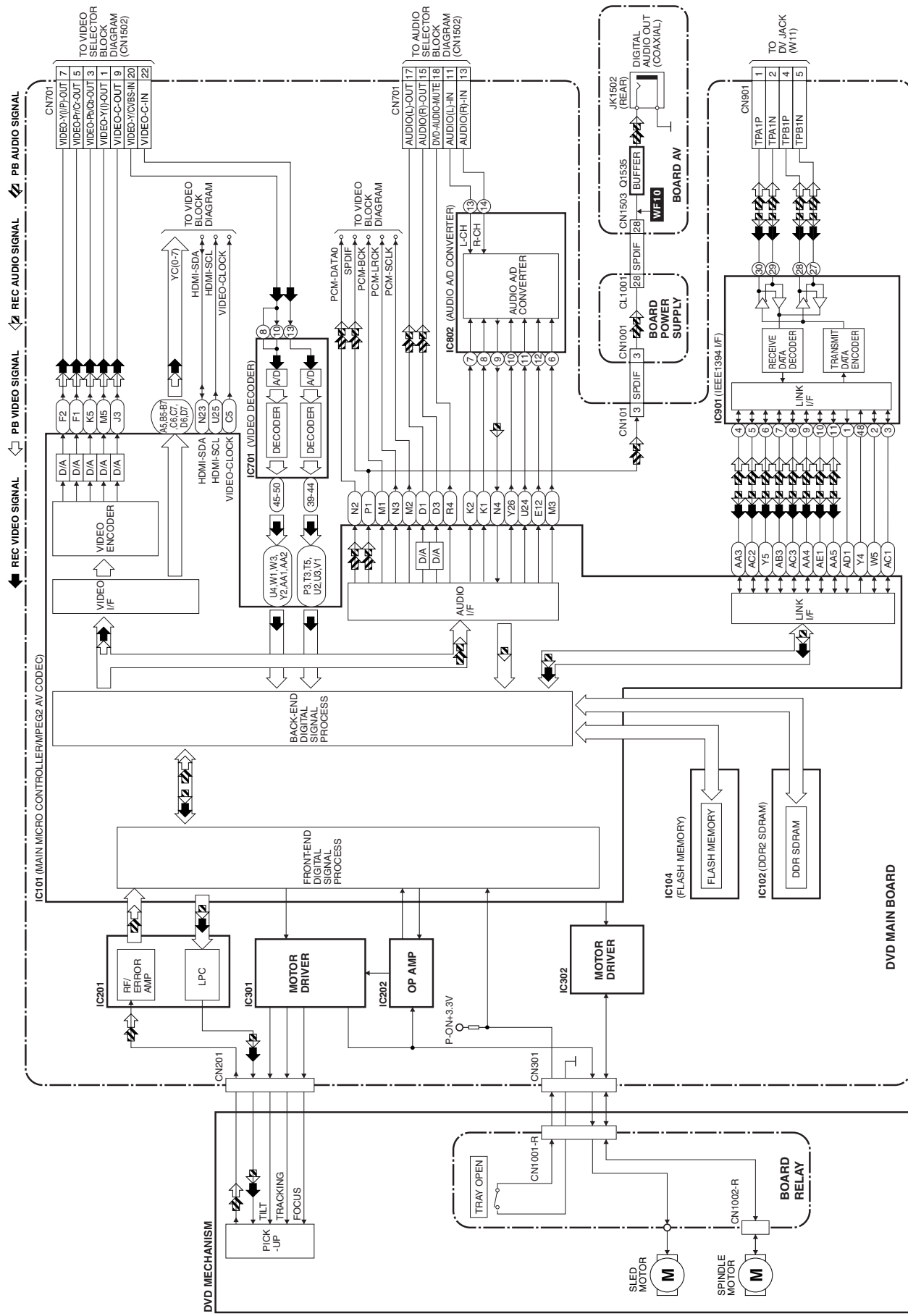

Video Selector Block Diagram

NOTE: BOARD MEANS PRINTED CIRCUIT BOARD.

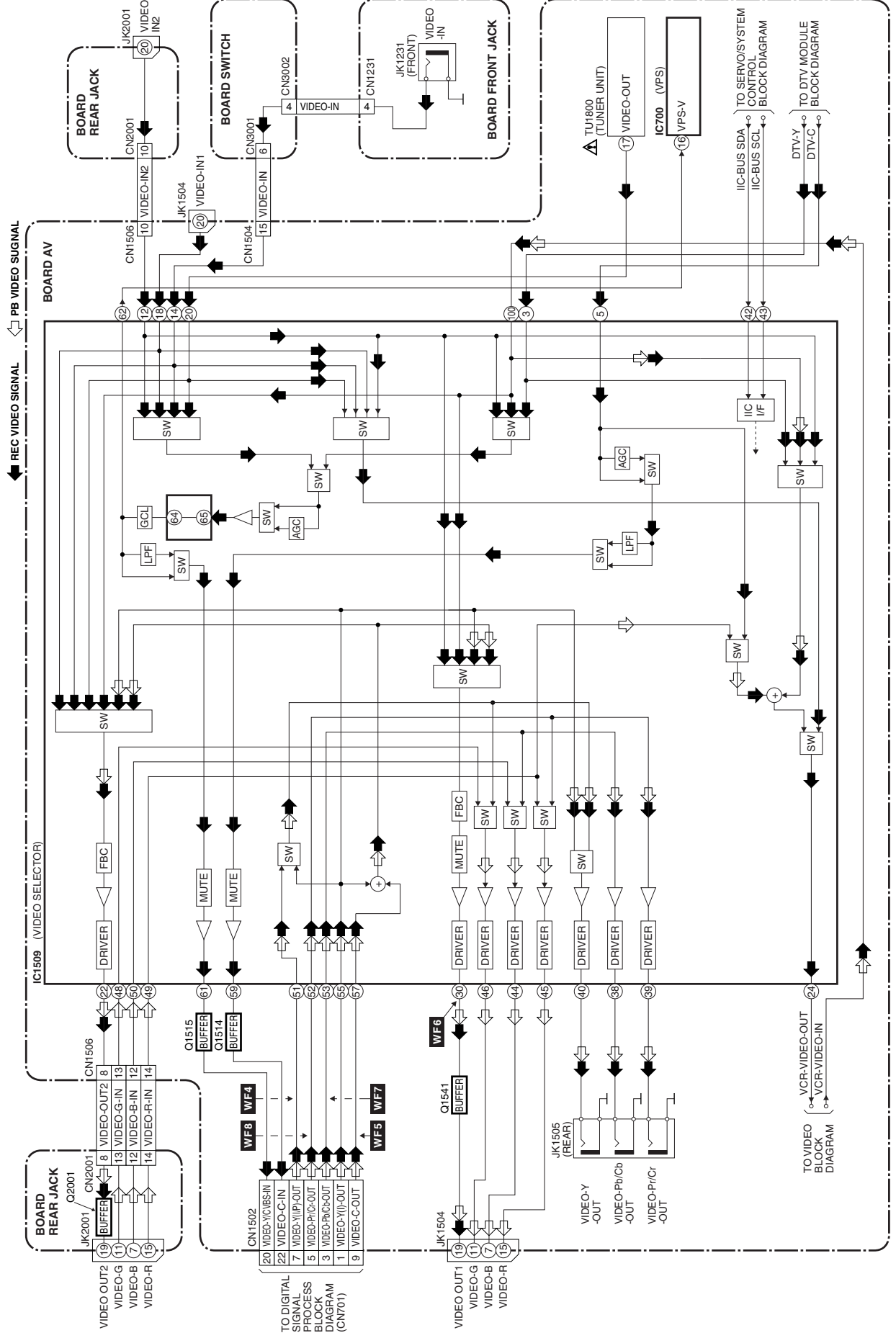

Video Block Diagram

NOTE: BOARD MEANS PRINTED CIRCUIT BOARD.

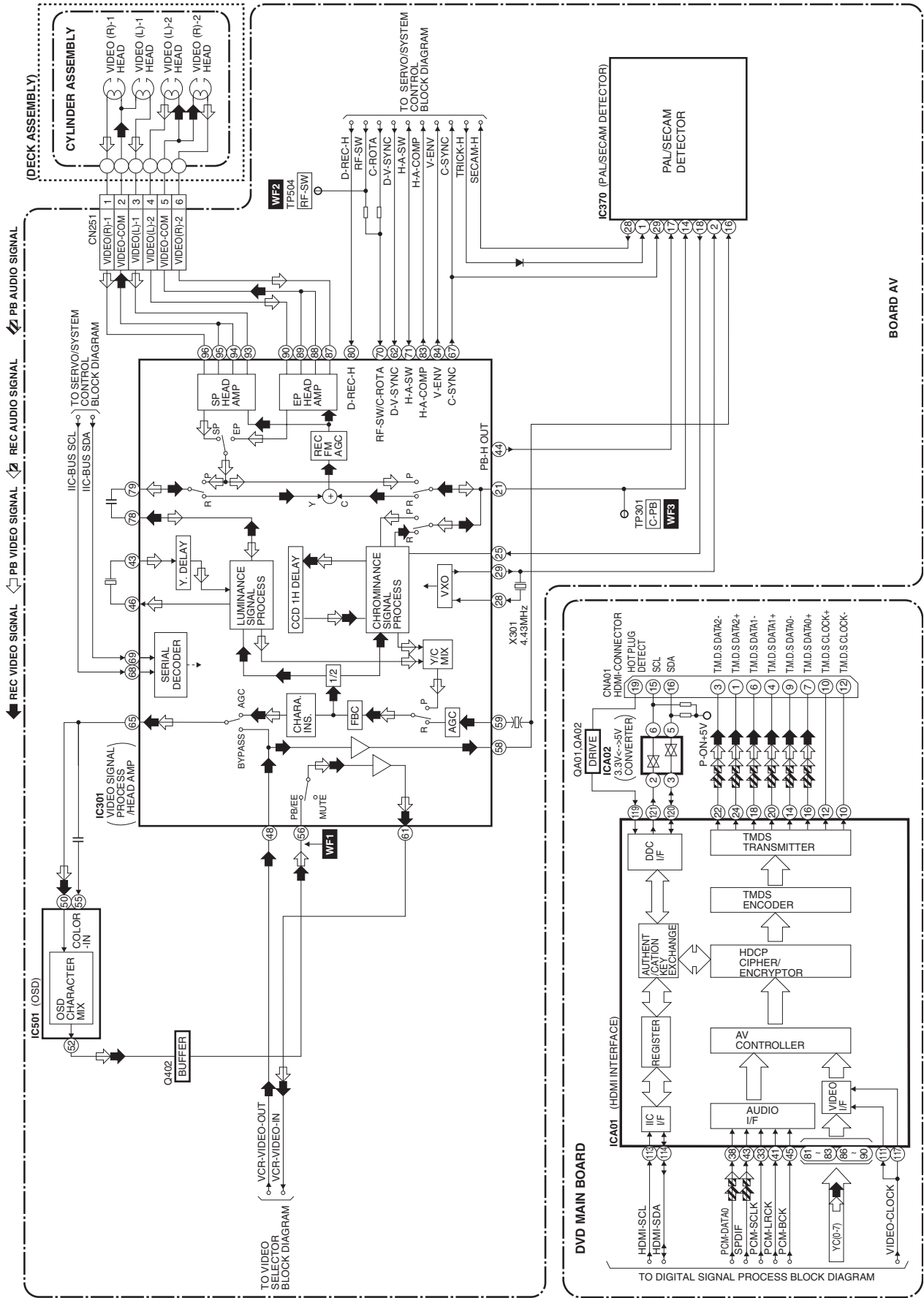

Audio Selector Block Diagram

NOTE: BOARD MEANS PRINTED CIRCUIT BOARD.

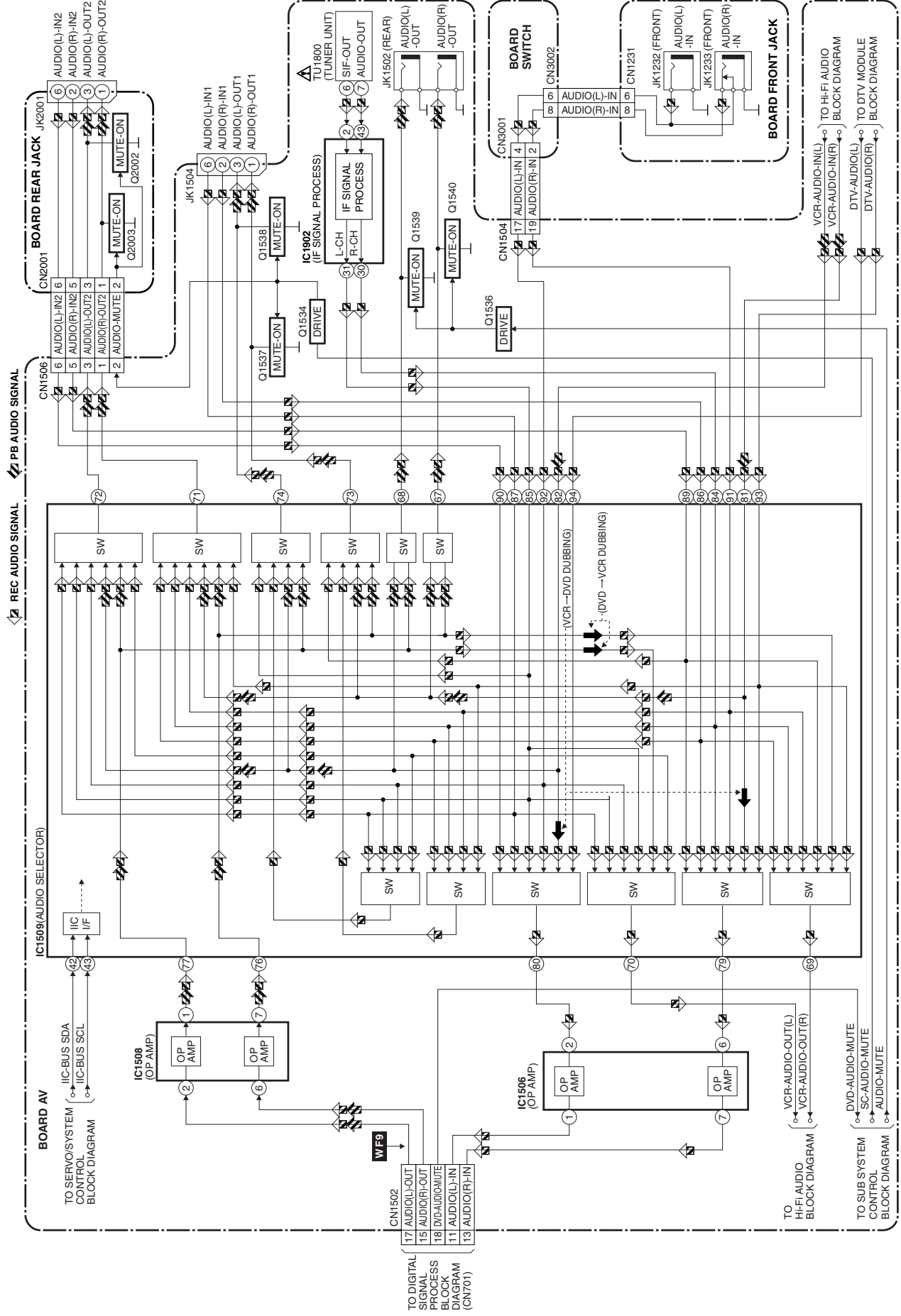

Audio Block Diagram

NOTE: BOARD MEANS PRINTED CIRCUIT BOARD.

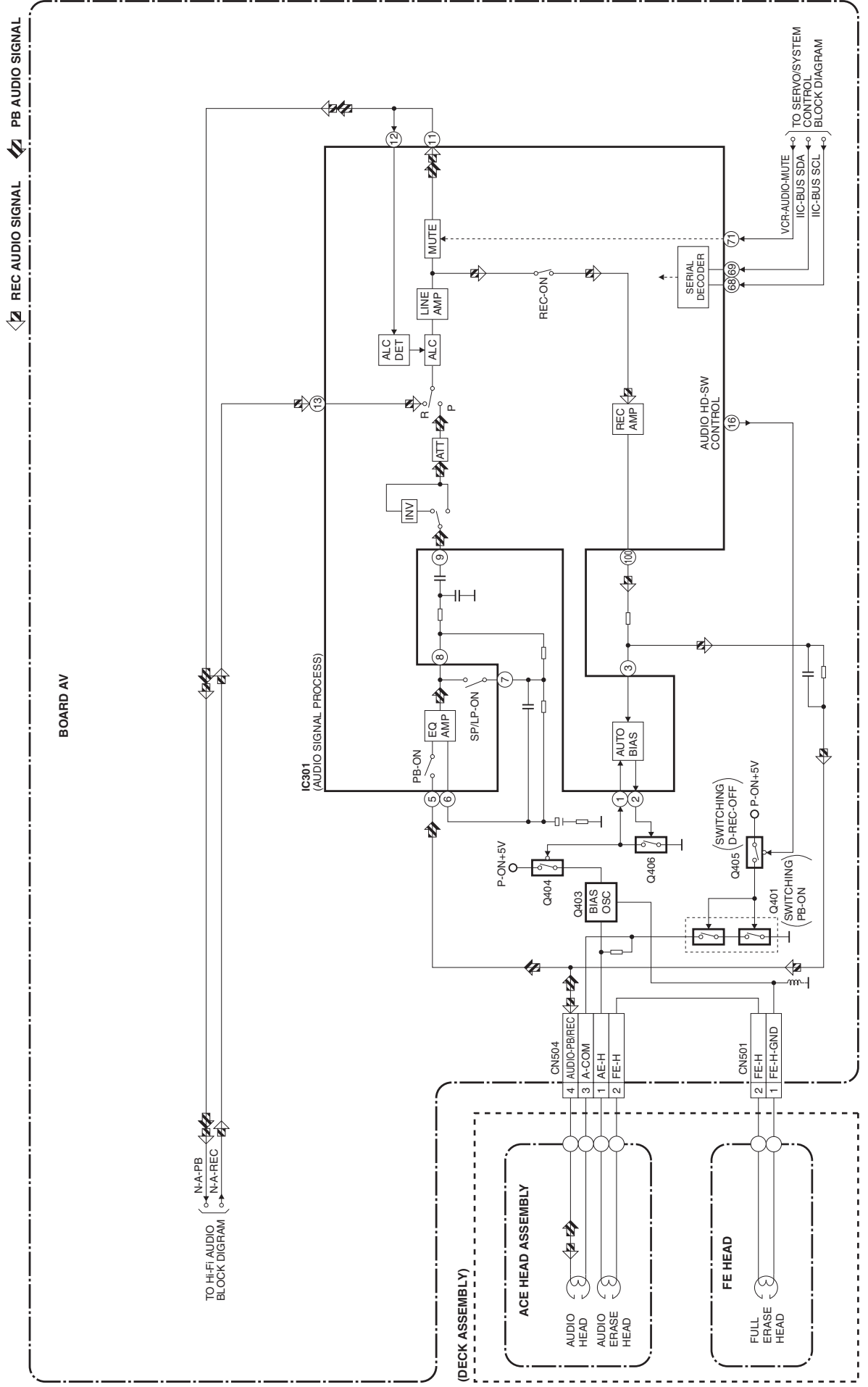

Hi-Fi Audio Block Diagram

NOTE: BOARD MEANS PRINTED CIRCUIT BOARD.

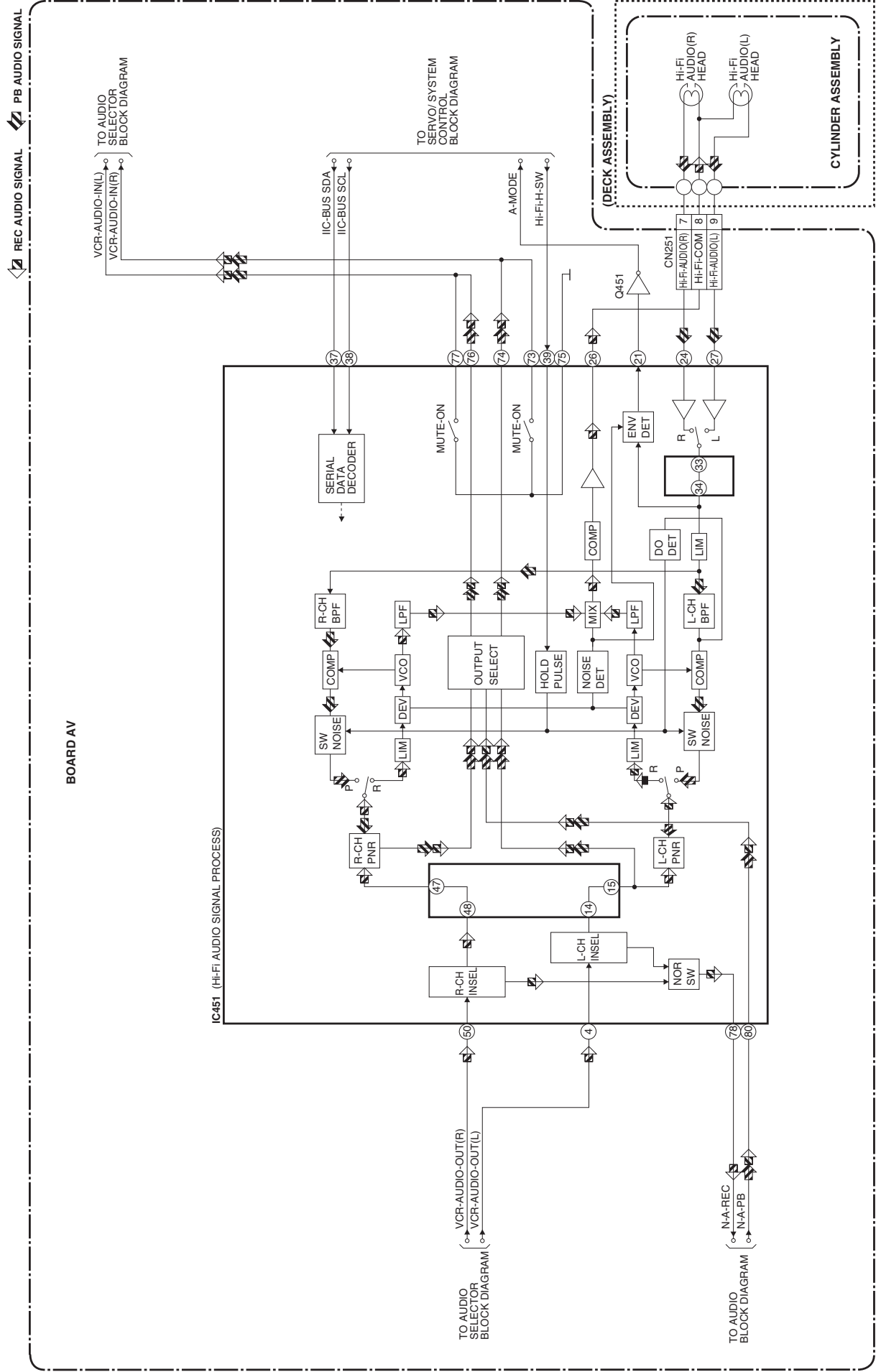

Power Supply Block Diagram

NOTE: BOARD MEANS PRINTED CIRCUIT BOARD.

CAUTION !
For continued protection against fire hazard, replace only with the same type fuse.

NOTE:
The voltage for parts in hot circuit is measured using hot GND as a common terminal.

CAUTION !
Fixed voltage (or Auto voltage selectable) power supply circuit is used in this unit. If Main Fuse (F1001) is blown, check to see that all components in the power supply circuit are not defective before you connect the AC plug to the AC power supply. Otherwise it may cause some components in the power supply circuit to fail.

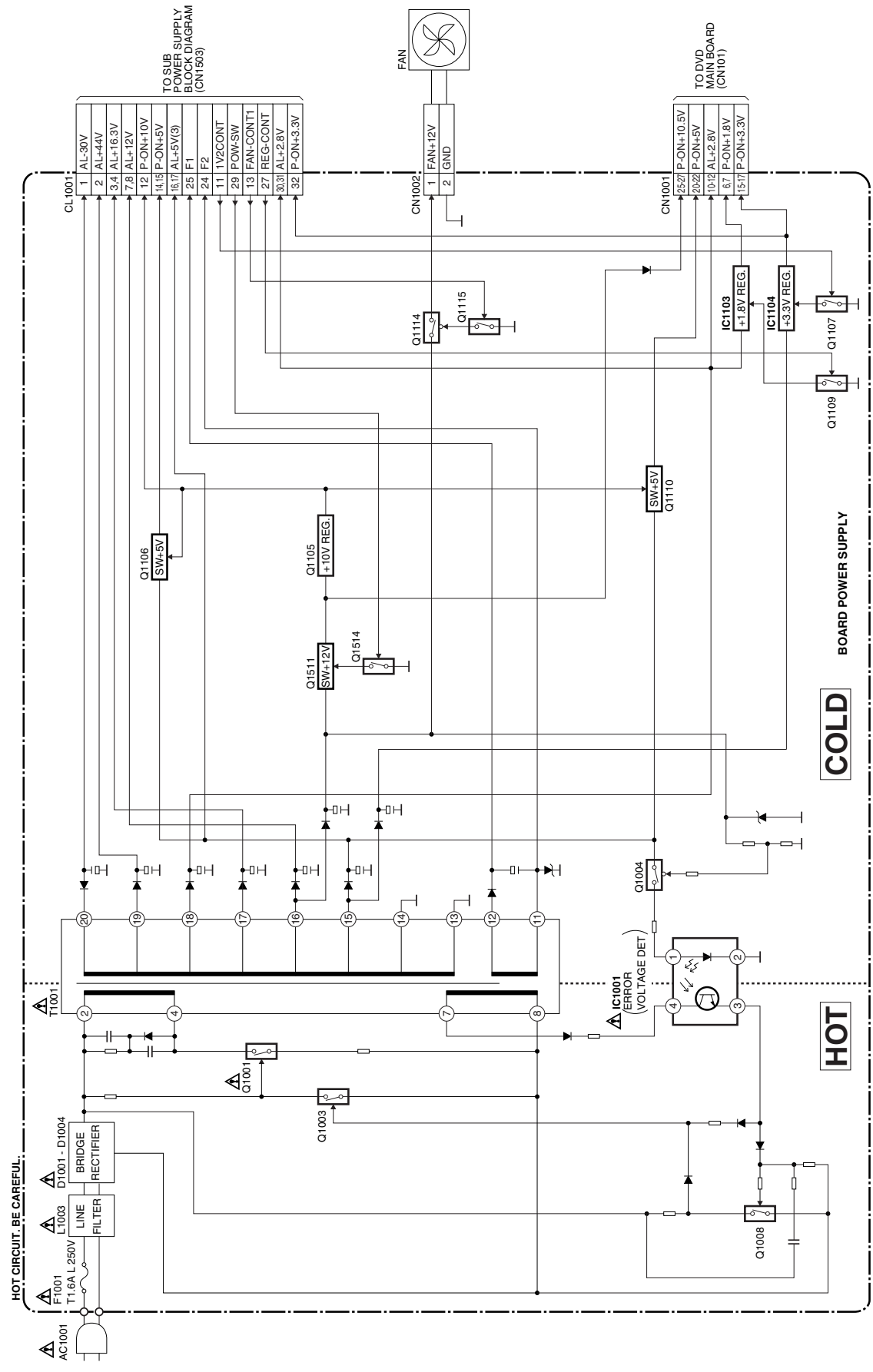

Sub Power Supply Block Diagram

NOTE: BOARD MEANS PRINTED CIRCUIT BOARD.

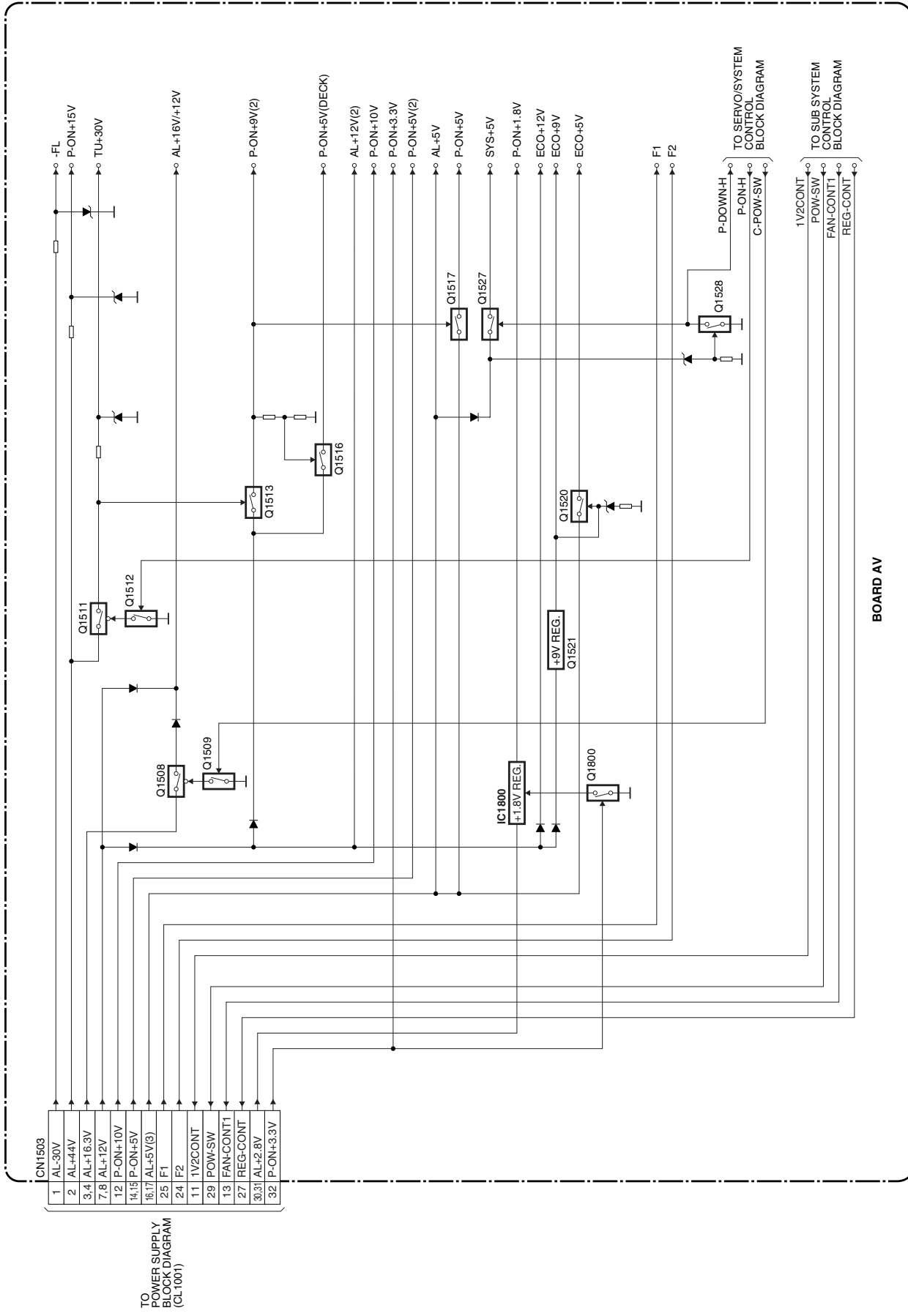

TO POWER SUPPLY BLOCK DIAGRAM (CL1001)

TO SERVO/SYSTEM CONTROL BLOCK DIAGRAM

TO SUB SYSTEM CONTROL BLOCK DIAGRAM

BOARD AV

DTV Module Block Diagram

NOTE: BOARD MEANS PRINTED CIRCUIT BOARD.

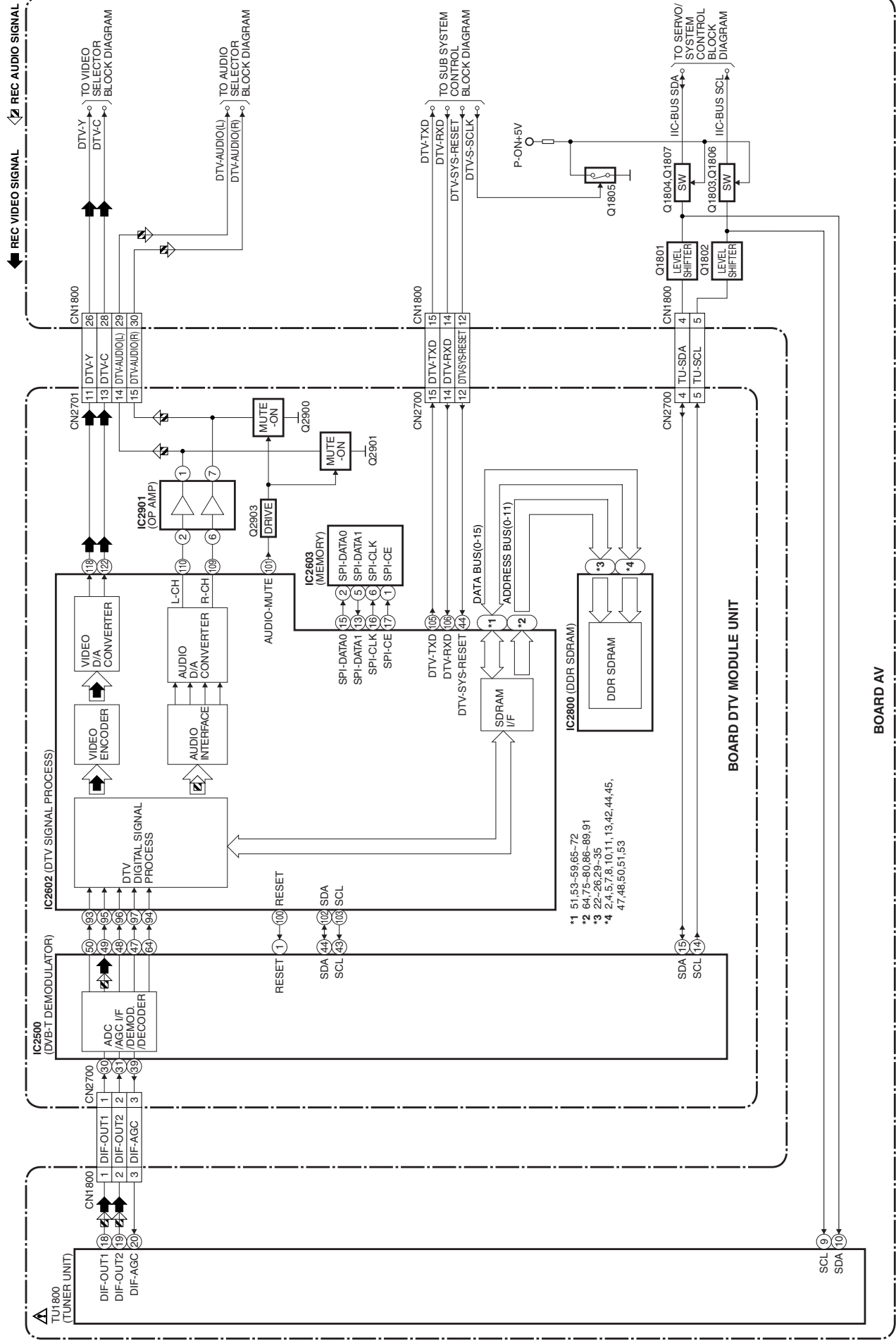

SCHEMATIC DIAGRAMS / BOARD'S AND TEST POINTS

NOTE: BOARD MEANS PRINTED CIRCUIT BOARD.

Standard Notes

WARNING

Many electrical and mechanical parts in this chassis have special characteristics. These characteristics often pass unnoticed and the protection afforded by them cannot necessarily be obtained by using replacement components rated for higher voltage, wattage, etc. Replacement parts that have these special safety characteristics are identified in this manual and its supplements; electrical components having such features are identified by the mark " \triangle " in the schematic diagram and the parts list. Before replacing any of these components, read the parts list in this manual carefully. The use of substitute replacement parts that do not have the same safety characteristics as specified in the parts list may create shock, fire, or other hazards.

Notes:

1. Do not use the part number shown on these drawings for ordering. The correct part number is shown in the parts list, and may be slightly different or amended since these drawings were prepared.
2. All resistance values are indicated in ohms ($K=10^3$, $M=10^6$).
3. Resistor wattages are 1/4W or 1/6W unless otherwise specified.
4. All capacitance values are indicated in μF ($P=10^{-6}$ μF).
5. All voltages are DC voltages unless otherwise specified.
6. Electrical parts such as capacitors, connectors, diodes, IC's, transistors, resistors, switches, and fuses are identified by four digits. The first two digits are not shown for each component. In each block of the diagram, there is a note such as shown below to indicate these abbreviated two digits.

LIST OF CAUTION, NOTES, AND SYMBOLS USED IN THE SCHEMATIC DIAGRAMS ON THE FOLLOWING PAGES:

1. CAUTION:

FOR CONTINUED PROTECTION AGAINST FIRE HAZARD, REPLACE ONLY WITH THE SAME TYPE FUSE.

2. CAUTION:

Fixed Voltage (or Auto voltage selectable) power supply circuit is used in this unit.

If Main Fuse (F1001) is blown, first check to see that all components in the power supply circuit are not defective before you connect the AC plug to the AC power supply. Otherwise it may cause some components in the power supply circuit to fail.

3. Note:

- Do not use the part number shown on the drawings for ordering. The correct part number is shown in the parts list, and may be slightly different or amended since the drawings were prepared.
- To maintain original function and reliability of repaired units, use only original replacement parts which are listed with their part numbers in the parts list section of the service manual.

4. Voltage indications for PLAY and REC modes on the schematics are as shown below:

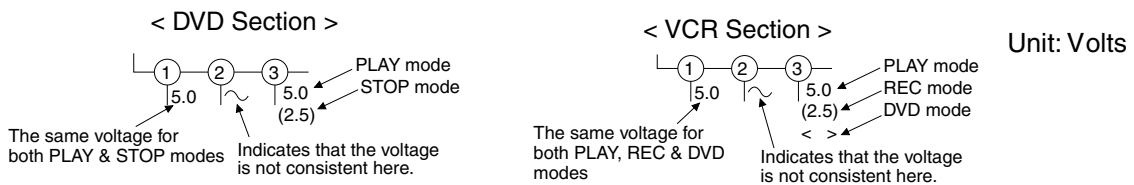

5. How to read converged lines

1-D3
 ↑ Distinction Area
 ↑ Line Number
 (1 to 3 digits)

Examples:

- "1-D3" means that line number "1" goes to the line number "1" of the area "D3".
- "1-B1" means that line number "1" goes to the line number "1" of the area "B1".

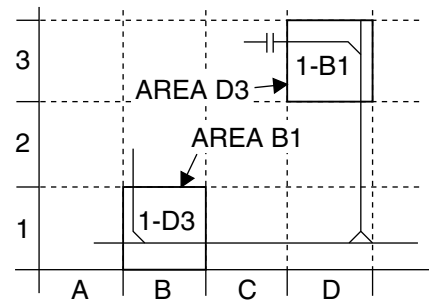

6. Test Point Information

- ⊕ : Indicates a test point with a jumper wire across a hole in the BOARD.
- : Used to indicate a test point with a component lead on foil side.
- ⊘ : Used to indicate a test point with no test pin.
- : Used to indicate a test point with a test pin.

AV 1/10 Schematic Diagram < VCR Section >

NOTE: BOARD MEANS PRINTED CIRCUIT BOARD.

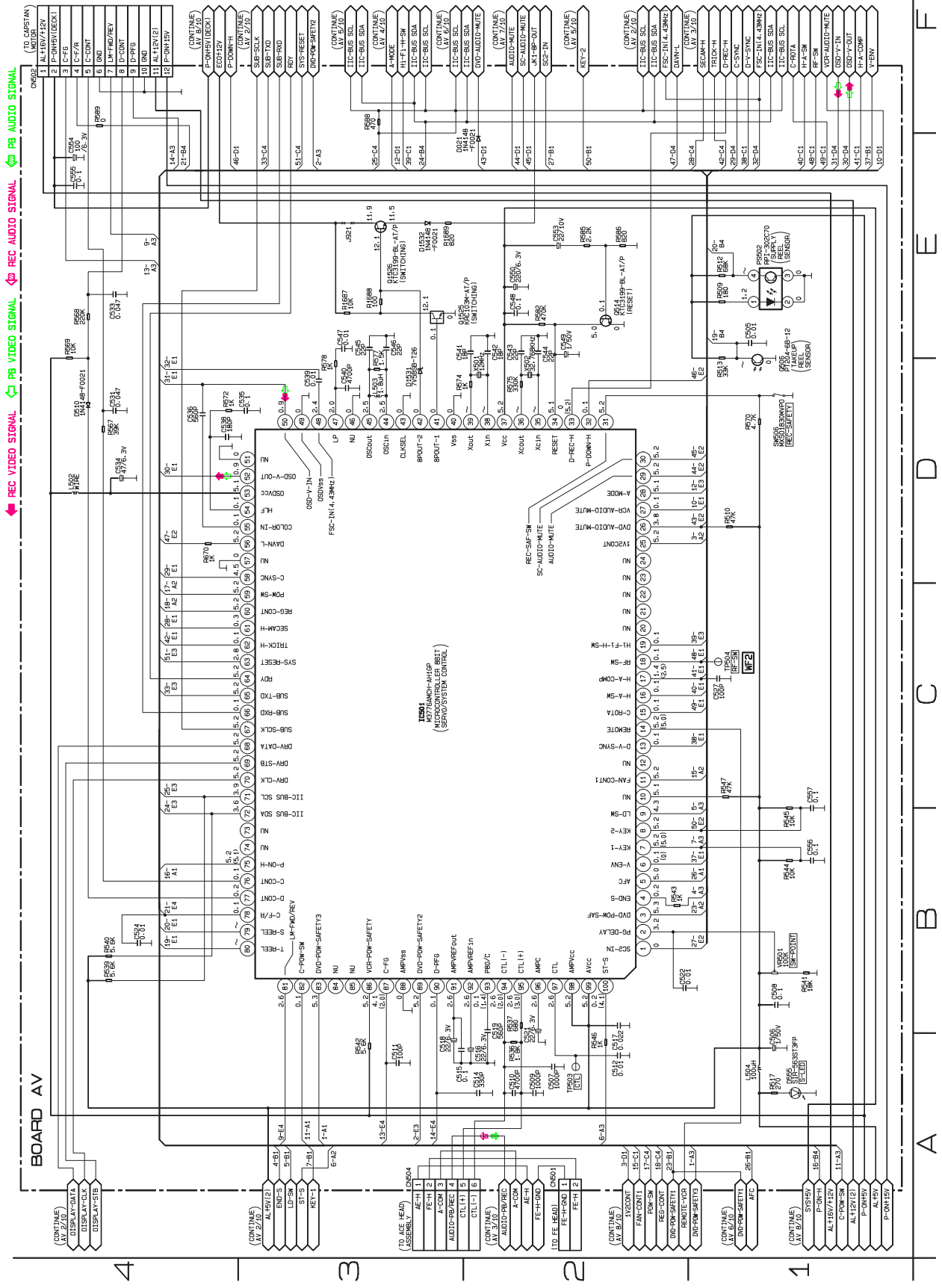

AV 2/10 , POWER SWITCH & SENSOR Schematic Diagram < VCR Section >

NOTE: BOARD MEANS PRINTED CIRCUIT BOARD.

FL601 MATRIX CHART

7G	6G	5G	4G	3G	2G	1G
P1	a	a	a	a	a	a
P2	b	b	b	b	b	b
P3	f	f	f	f	f	f
P4	9	9	9	9	9	9
P5	c	c	c	c	c	c
P6	e	e	e	e	e	e
P7	d	d	d	d	d	d
P8	S1	■	■	■	■	■
P9	PM	DTV	BS	CS	DR	■

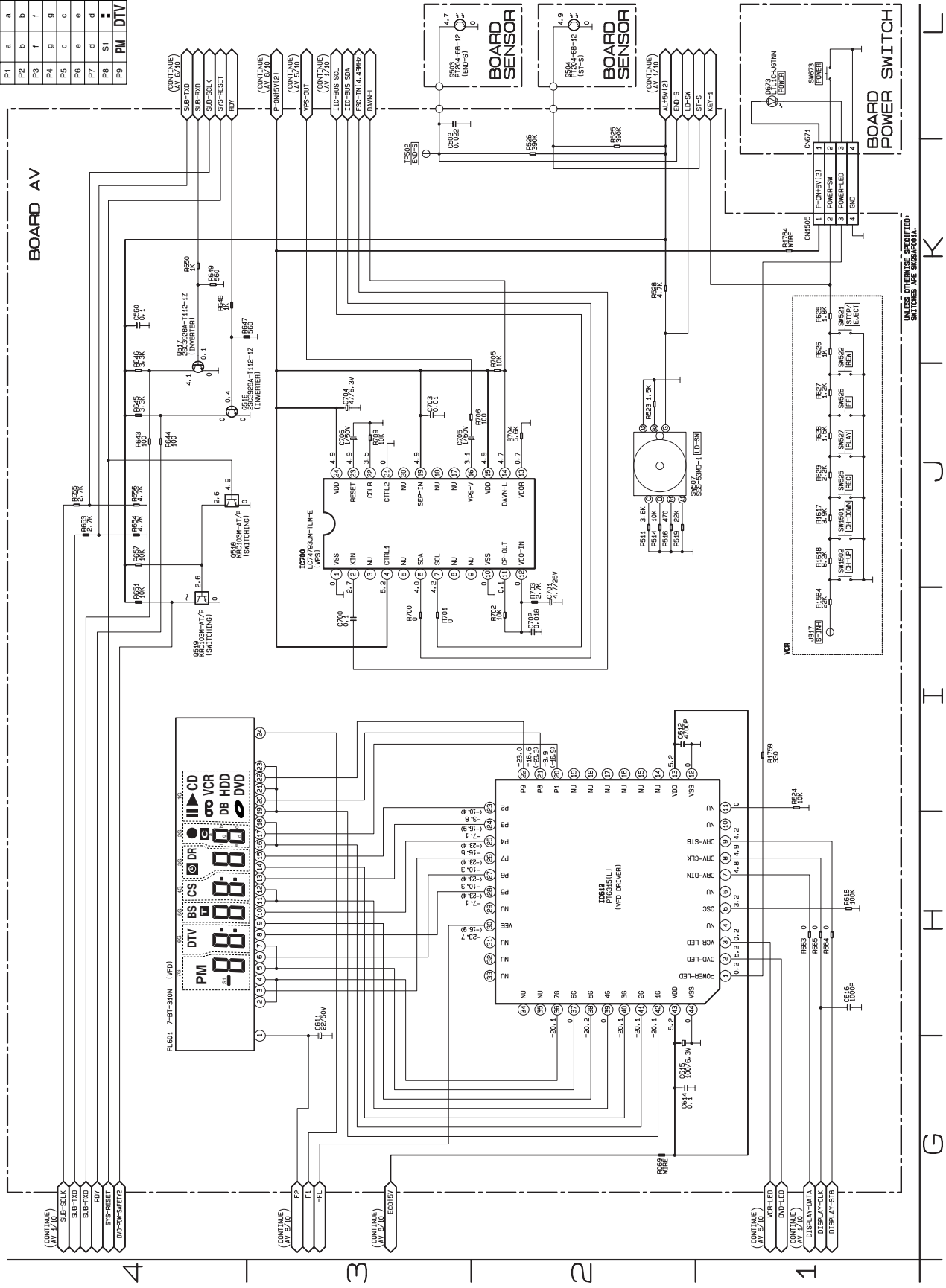

AV 3/10 Schematic Diagram < VCR Section >

NOTE: BOARD MEANS PRINTED CIRCUIT BOARD.

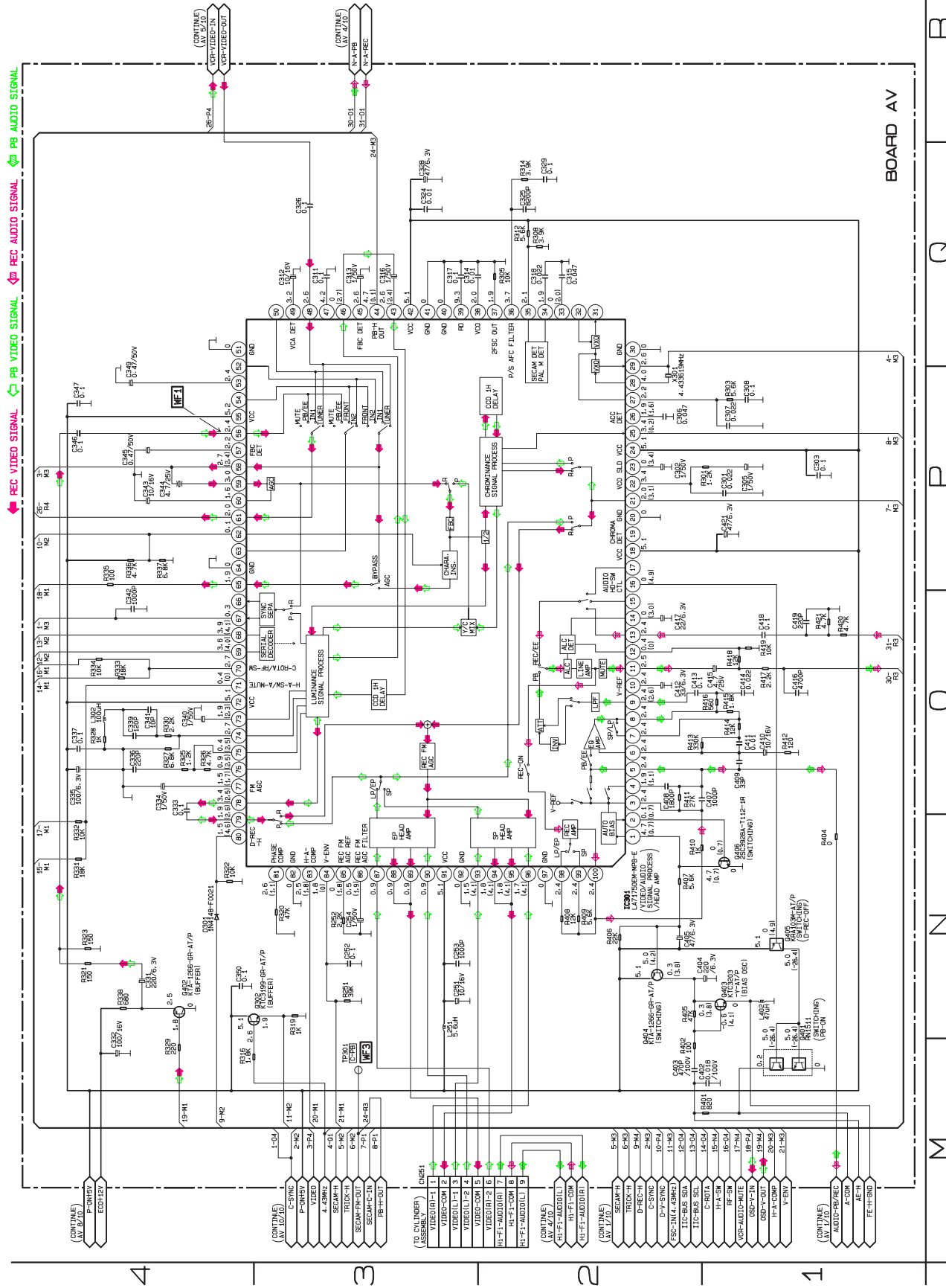

AV 4/10 Schematic Diagram < VCR Section >

NOTE: BOARD MEANS PRINTED CIRCUIT BOARD.

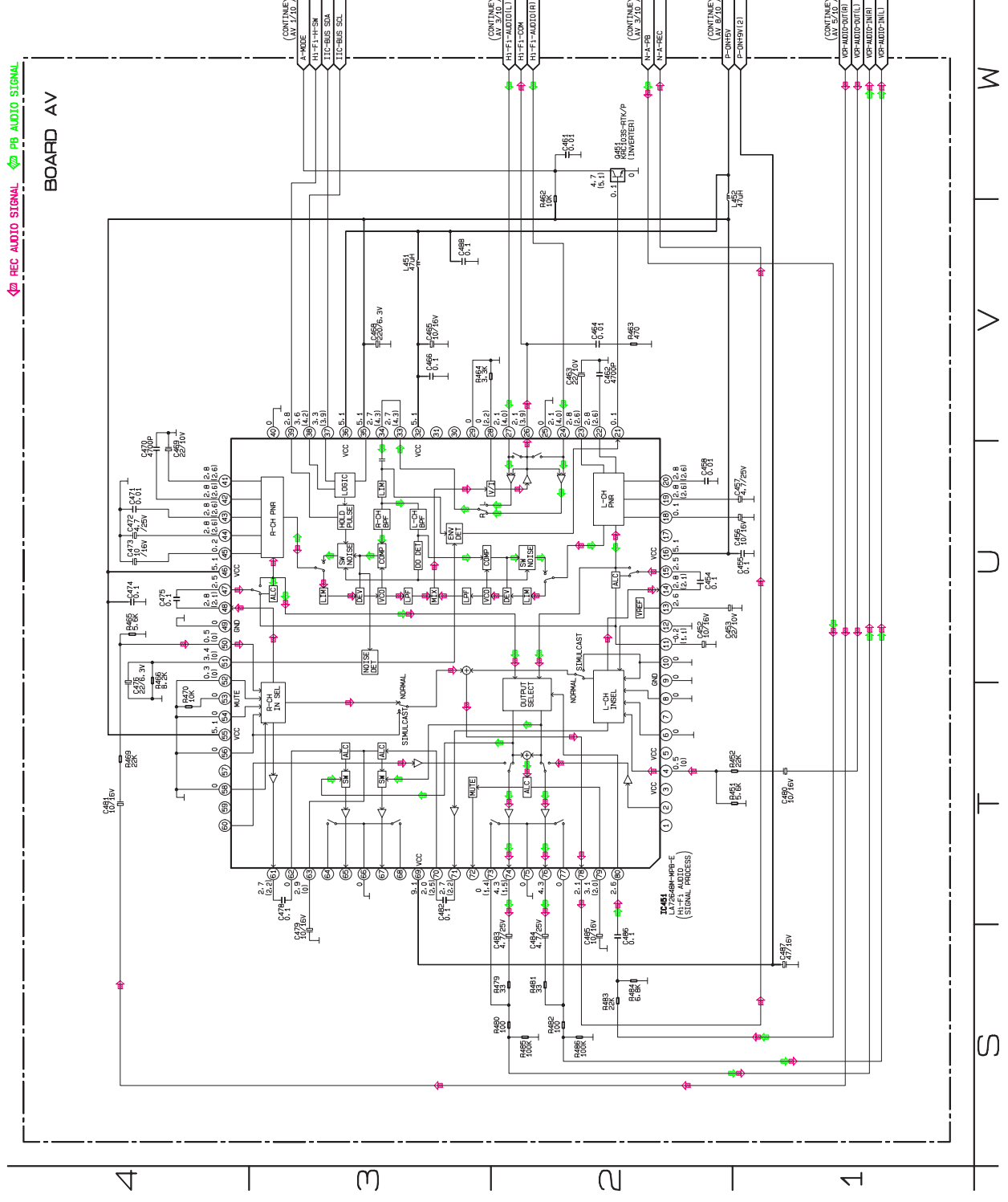

AV 5/10 Schematic Diagram < VCR Section >

NOTE: BOARD MEANS PRINTED CIRCUIT BOARD.

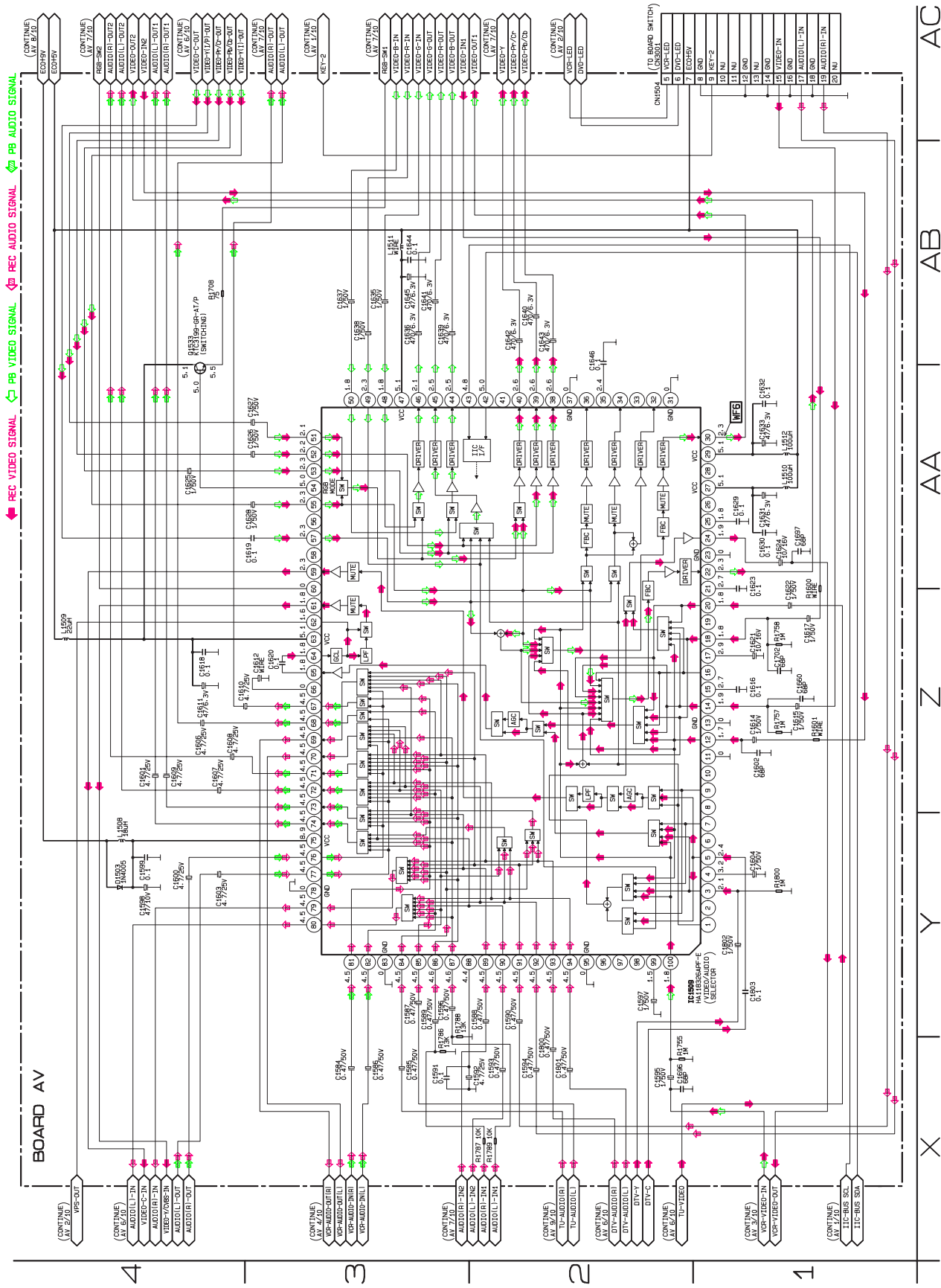

AV 6/10 Schematic Diagram < VCR Section >

NOTE: BOARD MEANS PRINTED CIRCUIT BOARD.

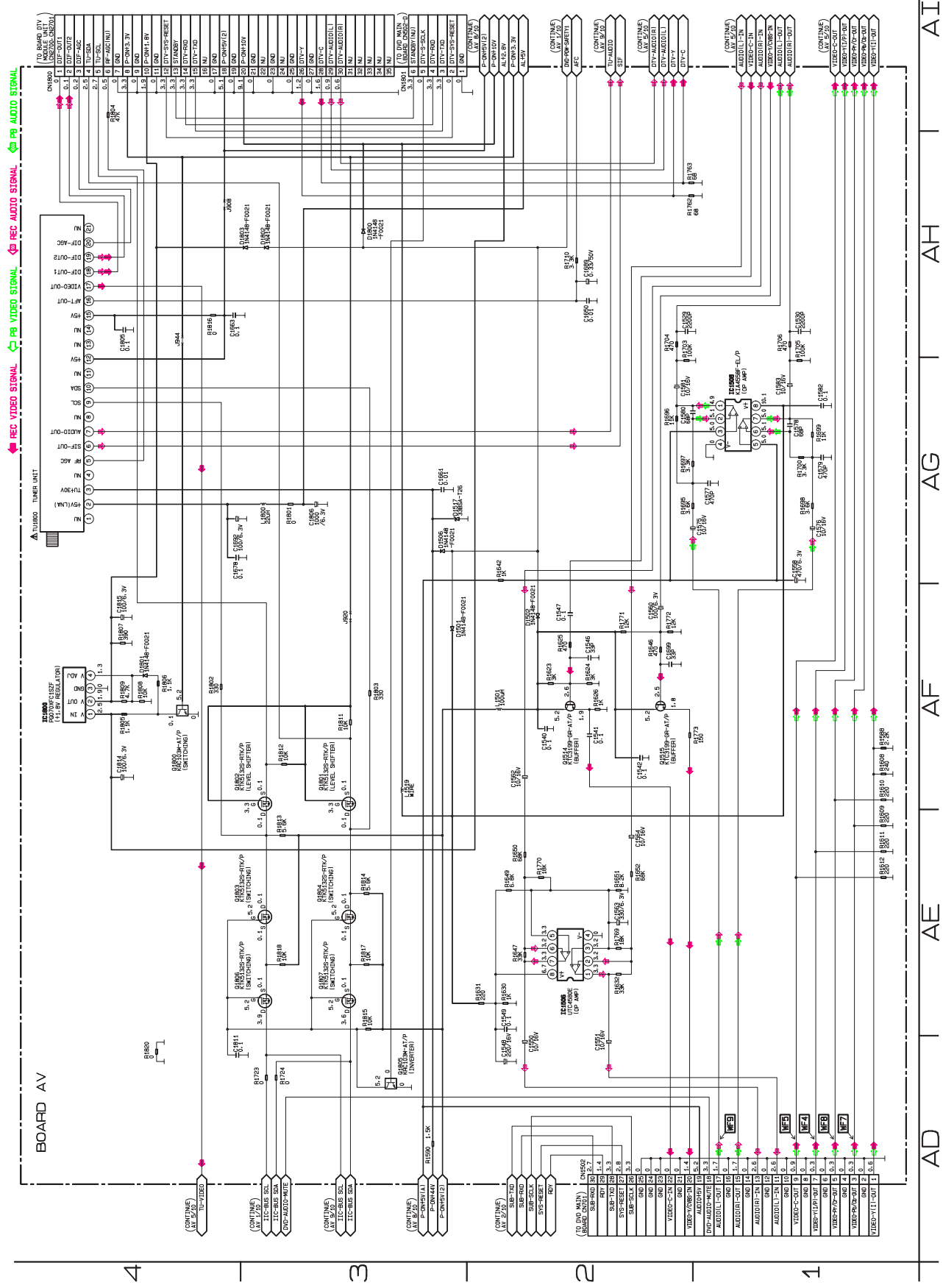

AV 710 Schematic Diagram < VCR Section >

NOTE: BOARD MEANS PRINTED CIRCUIT BOARD.

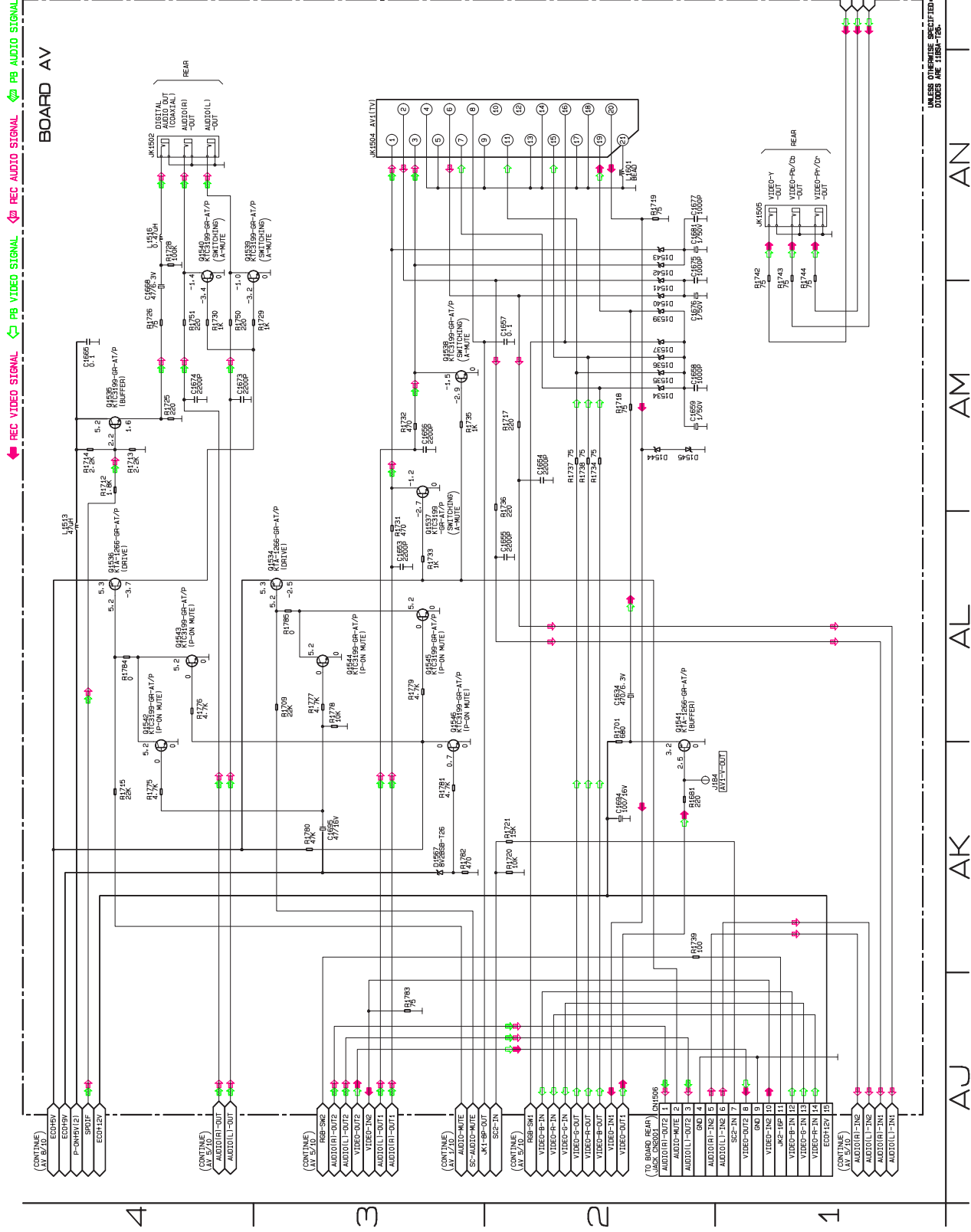

AV 9/10 Schematic Diagram < VCR Section >

NOTE: BOARD MEANS PRINTED CIRCUIT BOARD.

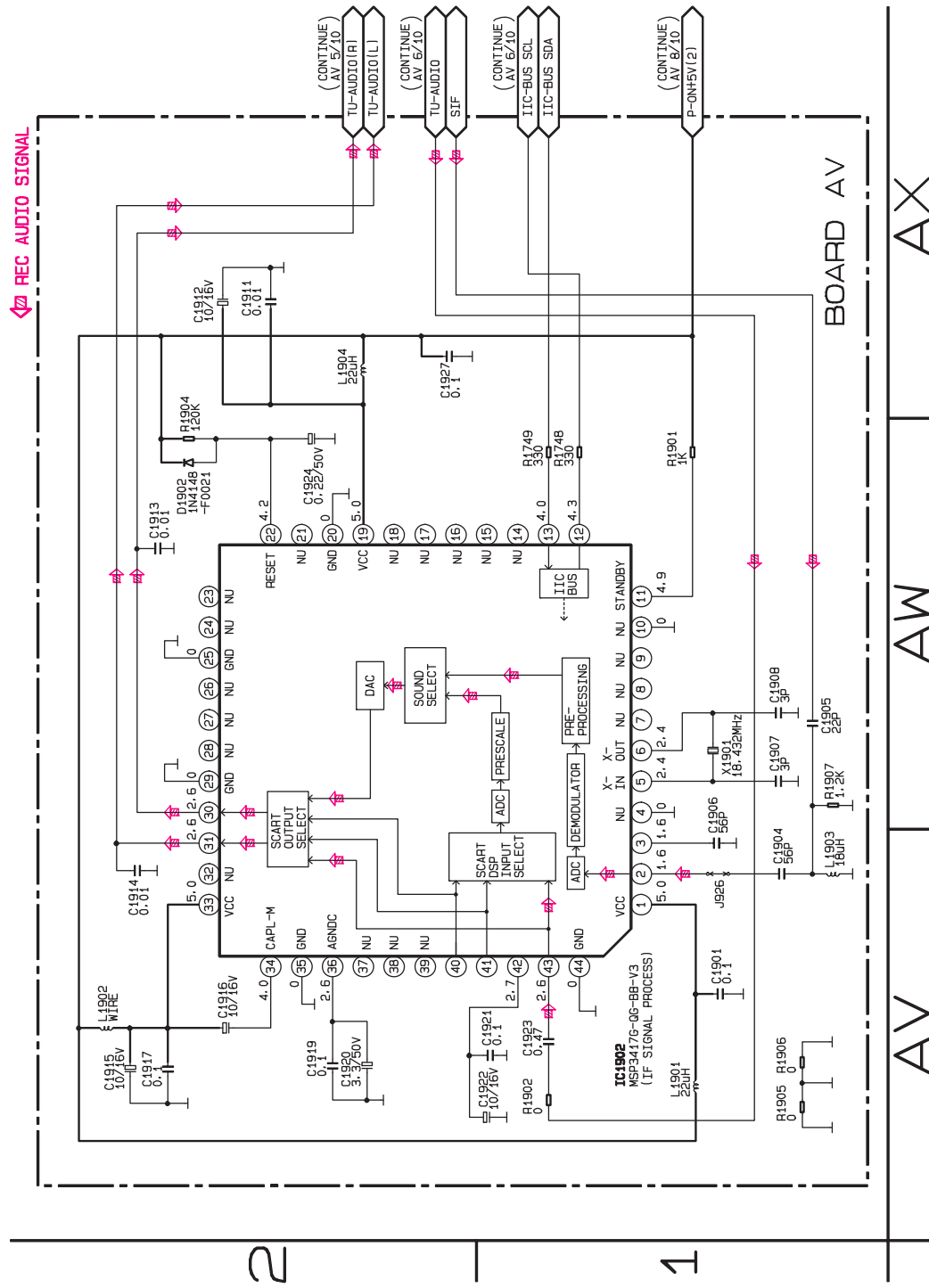

POWER SUPPLY Schematic Diagram < VCR Section >

CAUTION !

Fixed voltage (or Auto voltage selectable) power supply circuit is used in this unit.
 If Main Fuse (F1001) is blown, check to see that all components in the power supply circuit are not defective before you connect the AC plug to the AC power supply.
 Otherwise it may cause some components in the power supply circuit to fail.

CAUTION !

For continued protection against fire hazard, replace only with the same type fuse.

NOTE:

The voltage for parts in hot circuit is measured using hot GND as a common terminal.

NOTE: BOARD MEANS PRINTED CIRCUIT BOARD.

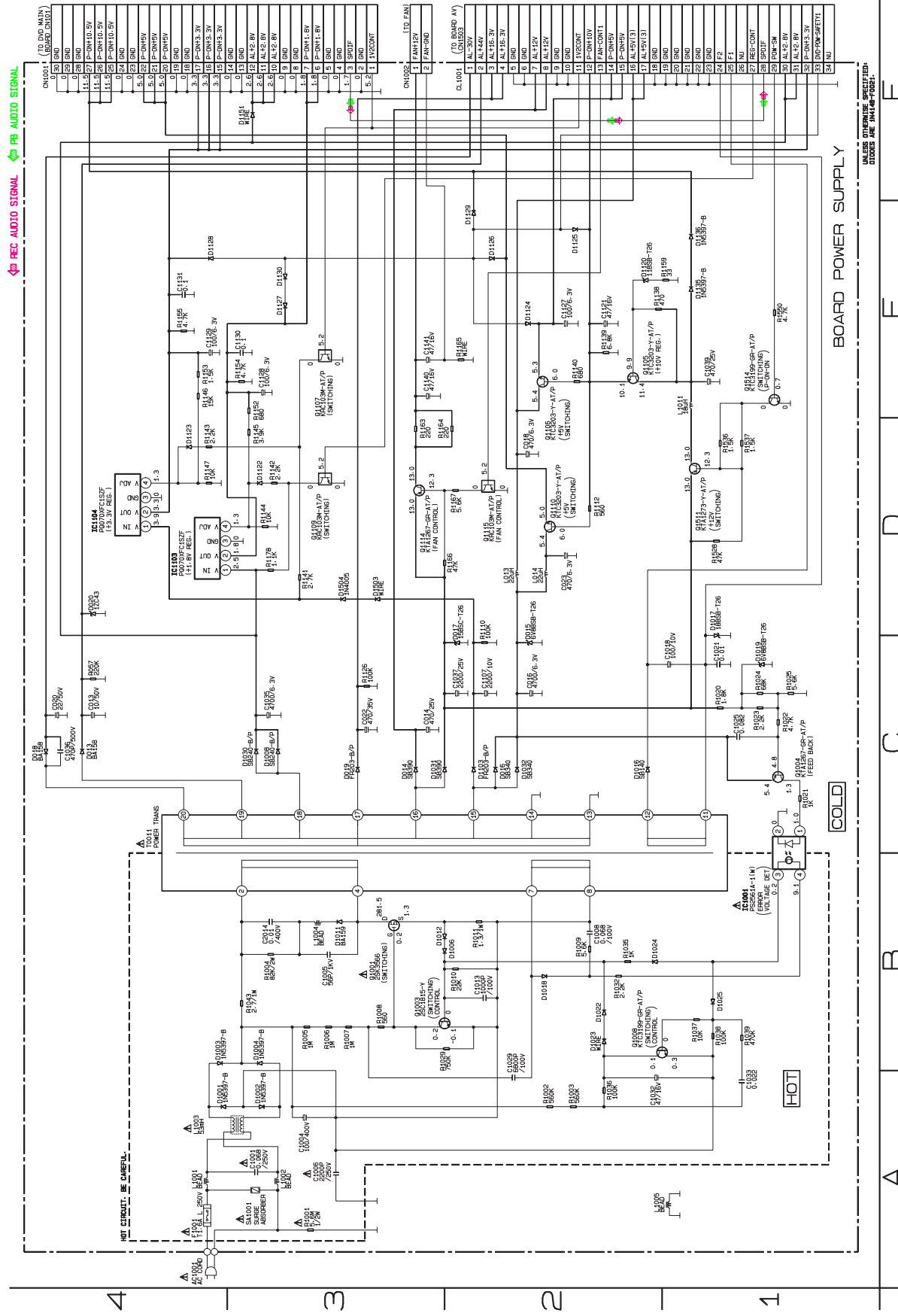

FRONT JACK Schematic Diagram < VCR Section >

NOTE: BOARD MEANS PRINTED CIRCUIT BOARD.
SWITCH & FUNCTION Schematic Diagram < VCR Section >

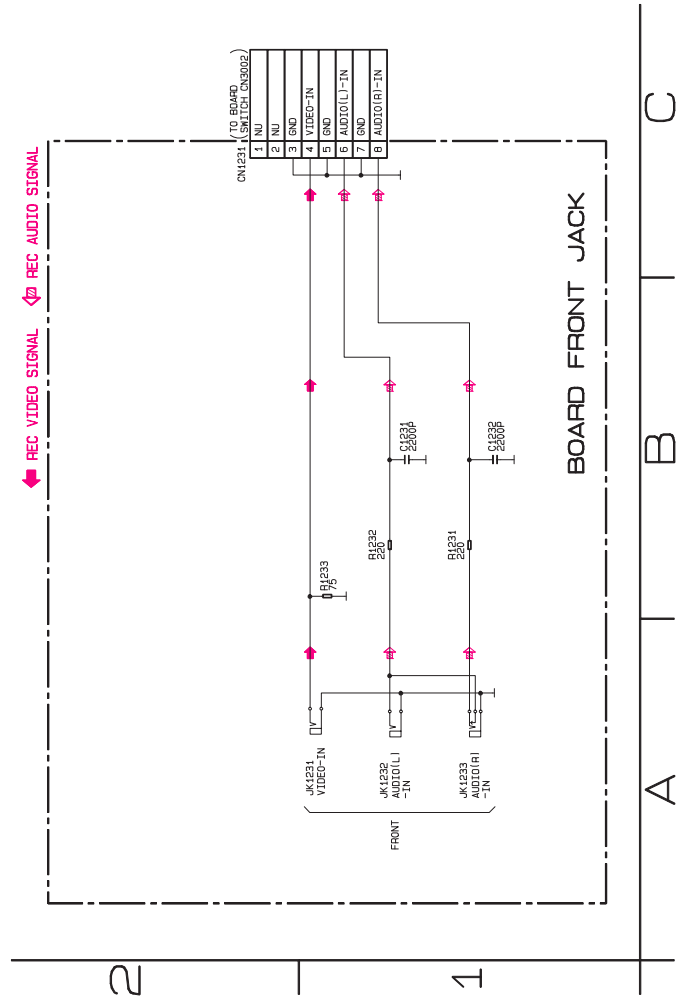

E9NG0SCFJ

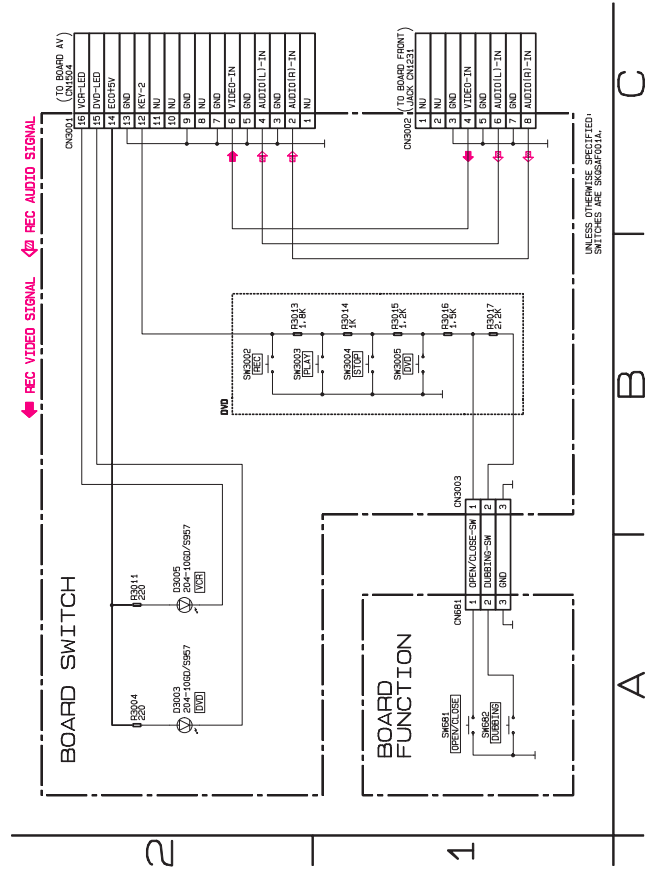

E9NG0SCSW

REAR JACK Schematic Diagram < VCR Section >

NOTE: BOARD MEANS PRINTED CIRCUIT BOARD.

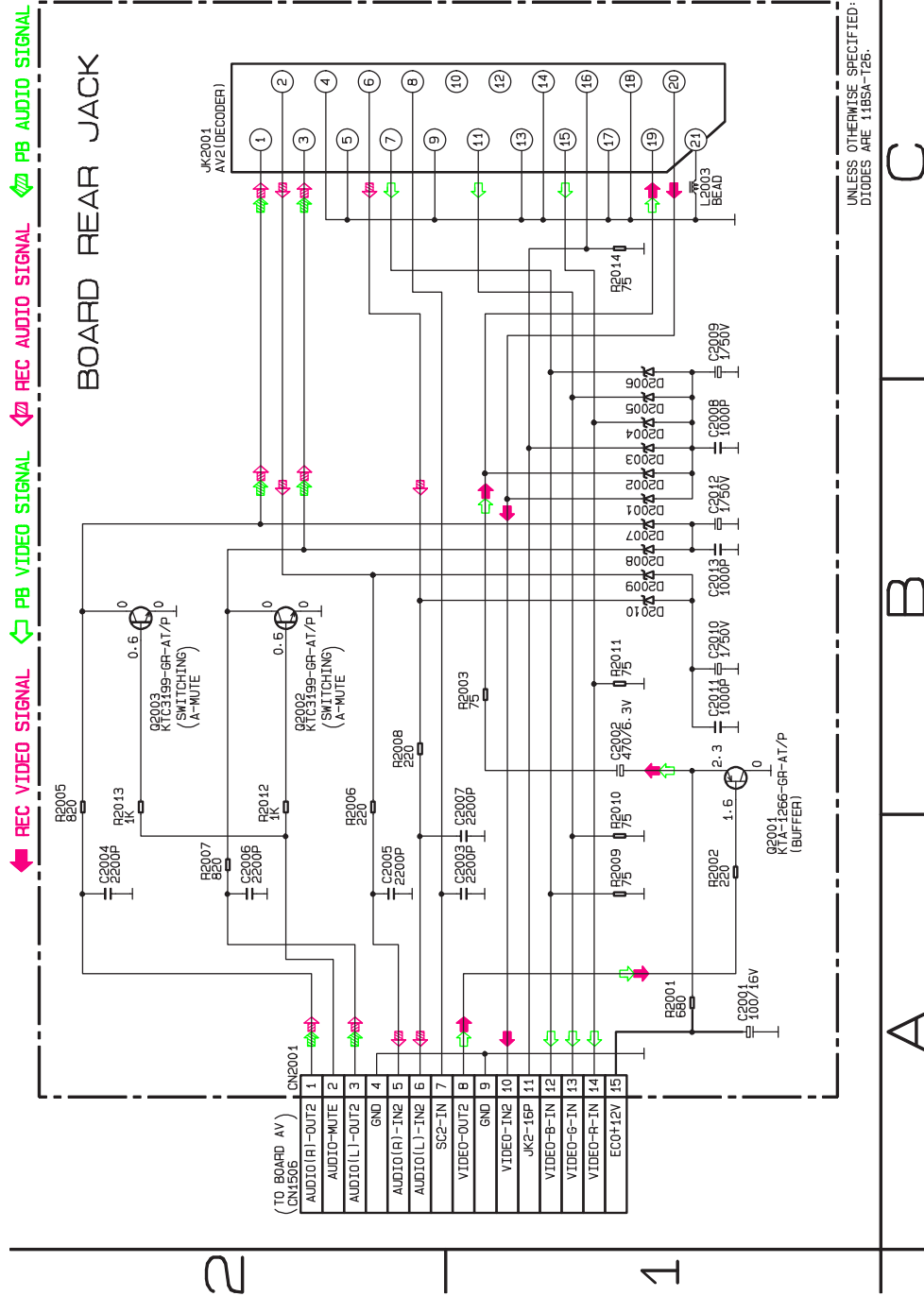

UNLESS OTHERWISE SPECIFIED:
DIODES ARE 1185A-T26.

DVD MAIN 1/7 Schematic Diagram < DVD Section >

*1 NOTE:
The order of pins shown in this diagram is different from that of actual IC101.
IC101 is divided into six and shown as IC101 (1/6) - IC101 (6/6) in this DVD Main Schematic Diagram Section.

NOTE: BOARD MEANS PRINTED CIRCUIT BOARD.

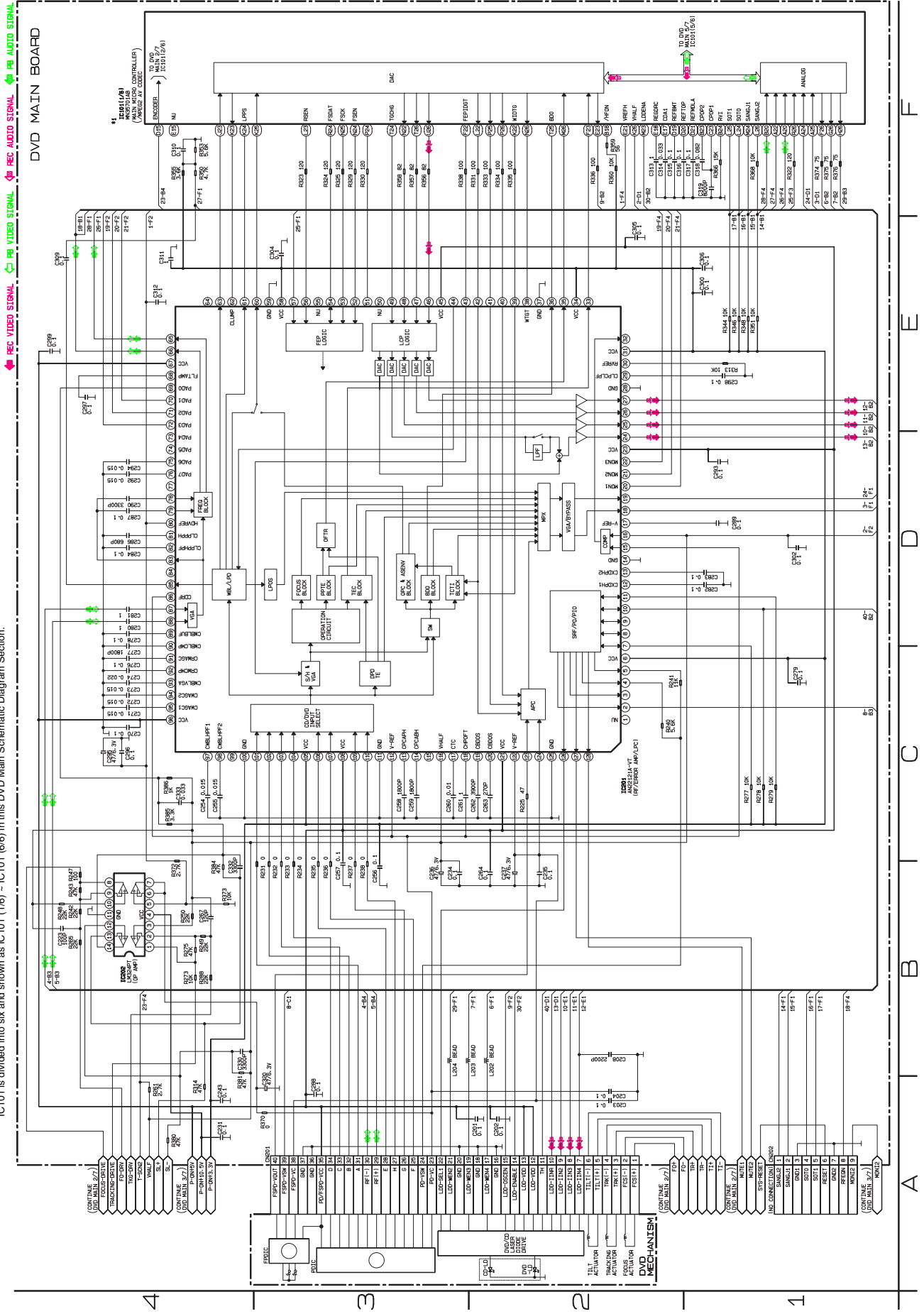

DVD MAIN 2/7 Schematic Diagram < DVD Section >

NOTE: BOARD MEANS PRINTED CIRCUIT BOARD.

*1 NOTE:
The order of pins shown in this diagram is different from that of actual IC101.
IC101 is divided into six and shown as IC101 (1/6) ~ IC101 (6/6) in this DVD Main Schematic Diagram Section.

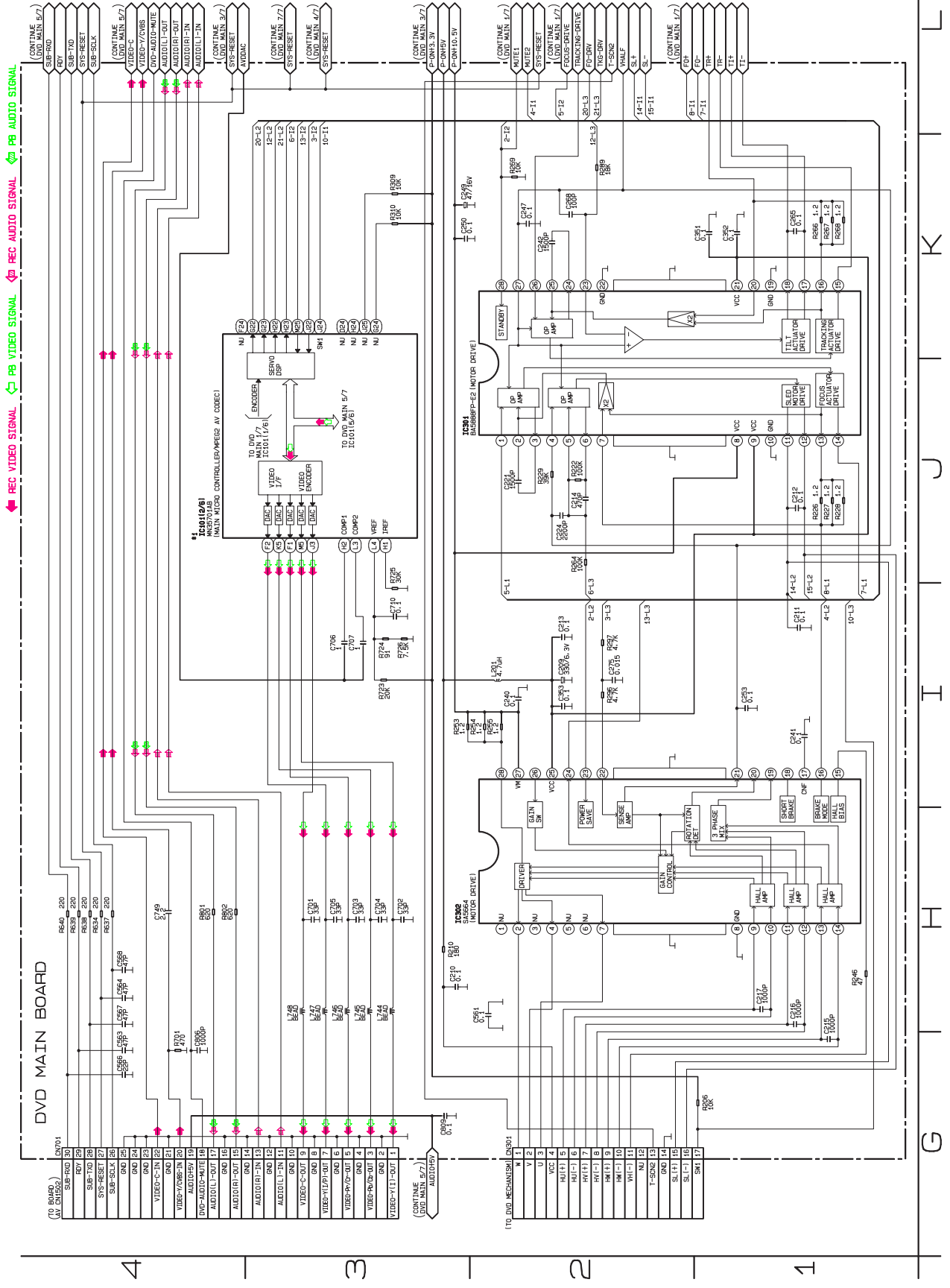

DVD MAIN 3/7 Schematic Diagram < DVD Section >

NOTE: BOARD MEANS PRINTED CIRCUIT BOARD.

*1 NOTE:
The order of pins shown in this diagram is different from that of actual IC101.
IC101 is divided into six and shown as IC101 (1/6) - IC101 (6/6) in this DVD Main Schematic Diagram Section.

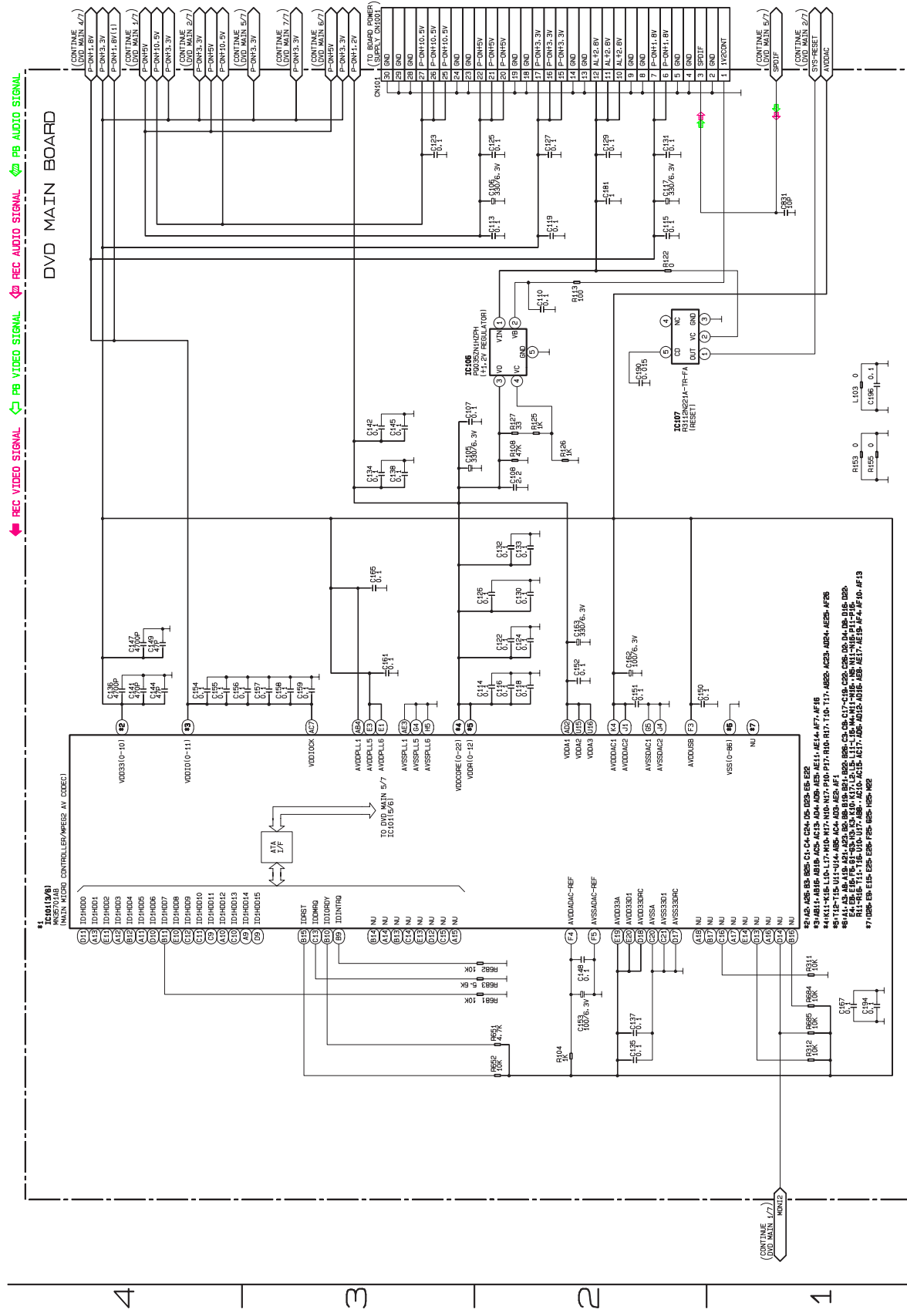

M | N | O | P | Q | R

DVD MAIN 4/7 Schematic Diagram < DVD Section >

NOTE: BOARD MEANS PRINTED CIRCUIT BOARD.

*1 NOTE:

The order of pins shown in this diagram is different from that of actual IC101.
IC101 is divided into six and shown as IC101 (1/6) ~ IC101 (6/6) in this DVD Main Schematic Diagram Section.

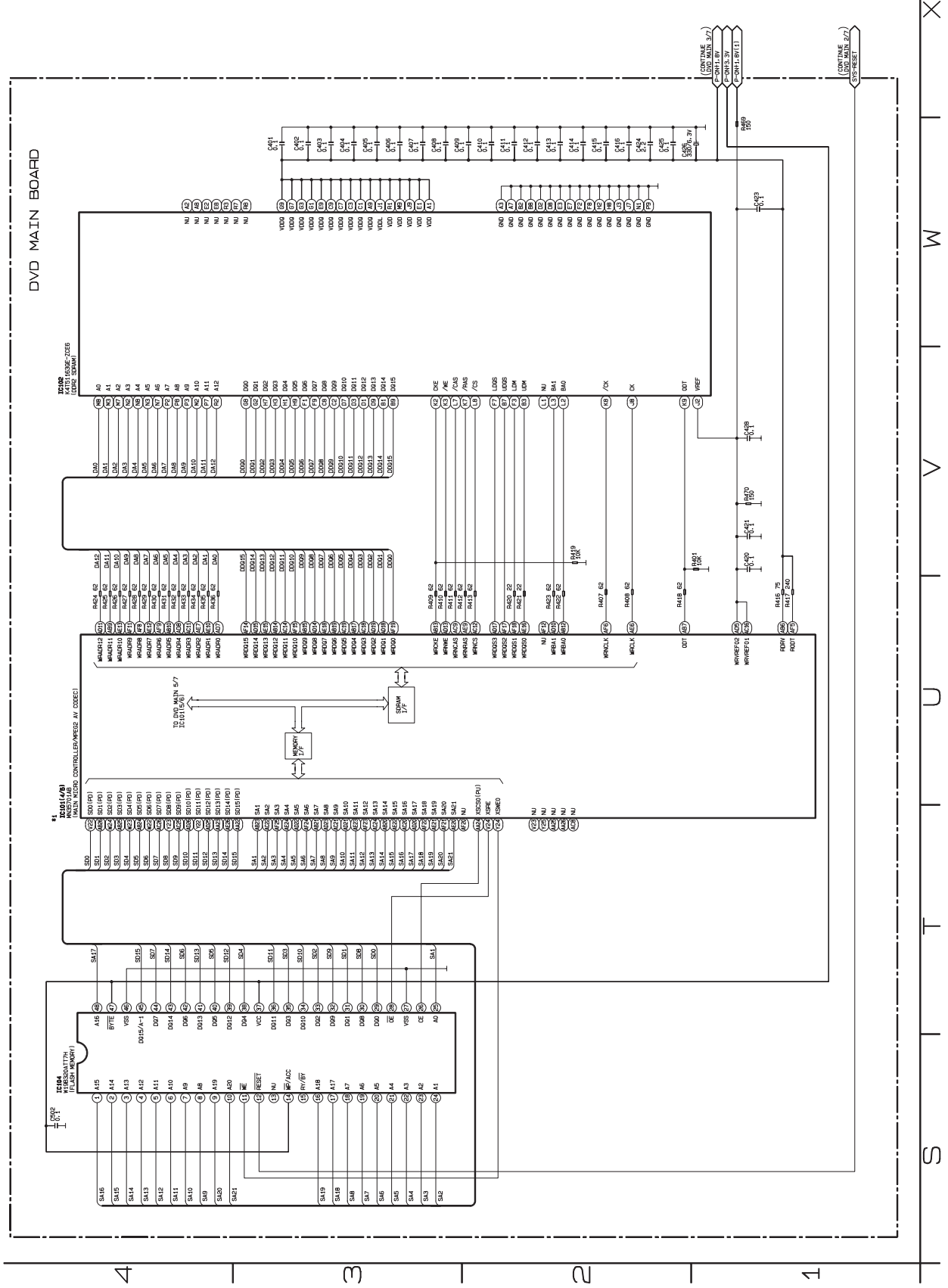

DVD MAIN 5/7 Schematic Diagram < DVD Section >

NOTE: BOARD MEANS PRINTED CIRCUIT BOARD.

*1 NOTE:
The order of pins shown in this diagram is different from that of actual IC101.
IC101 is divided into six and shown as IC101 (1/6) - IC101 (6/6) in this DVD Main Schematic Diagram Section.

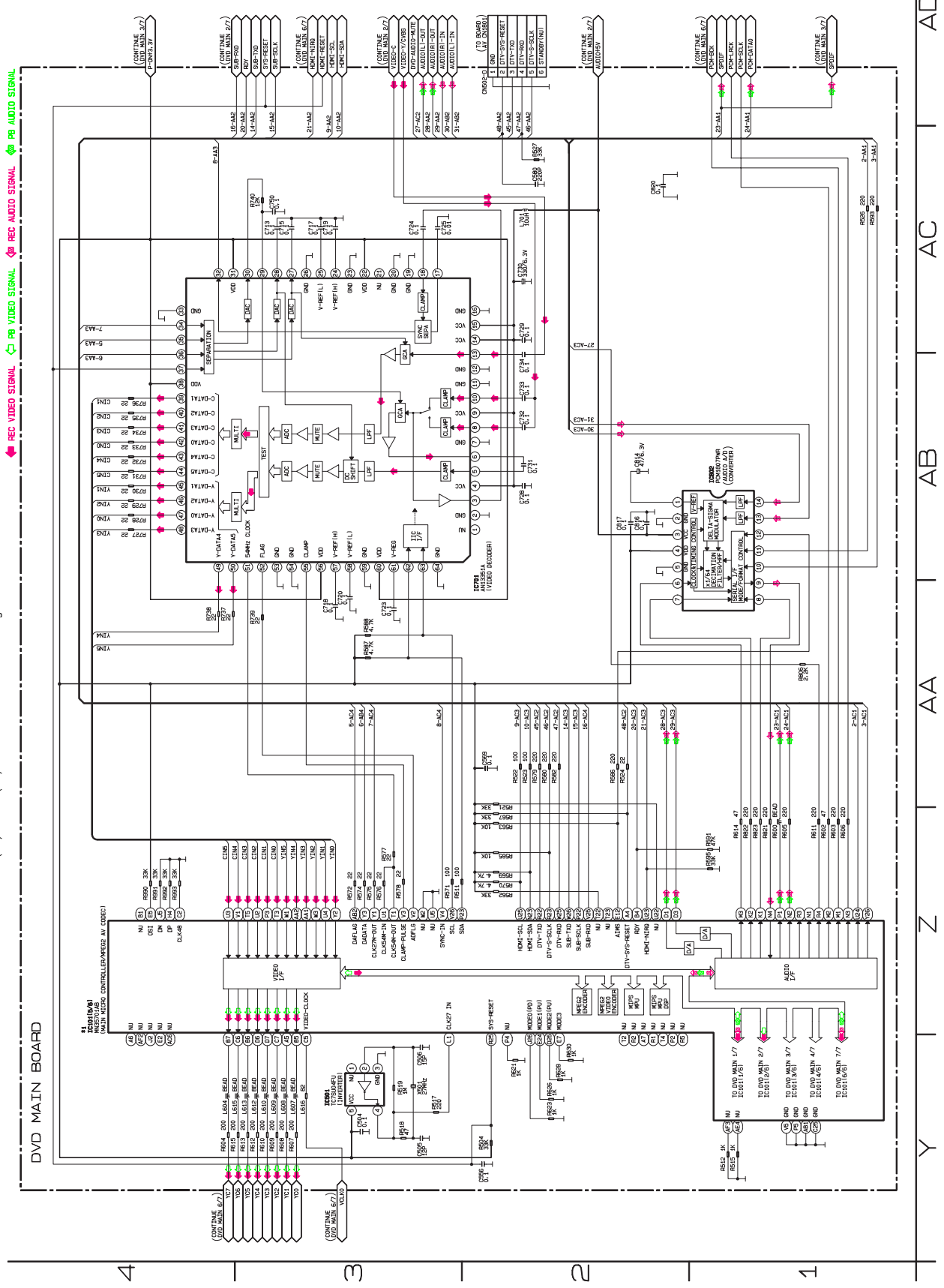

DVD MAIN 6/7 Schematic Diagram < DVD Section >

NOTE: BOARD MEANS PRINTED CIRCUIT BOARD.

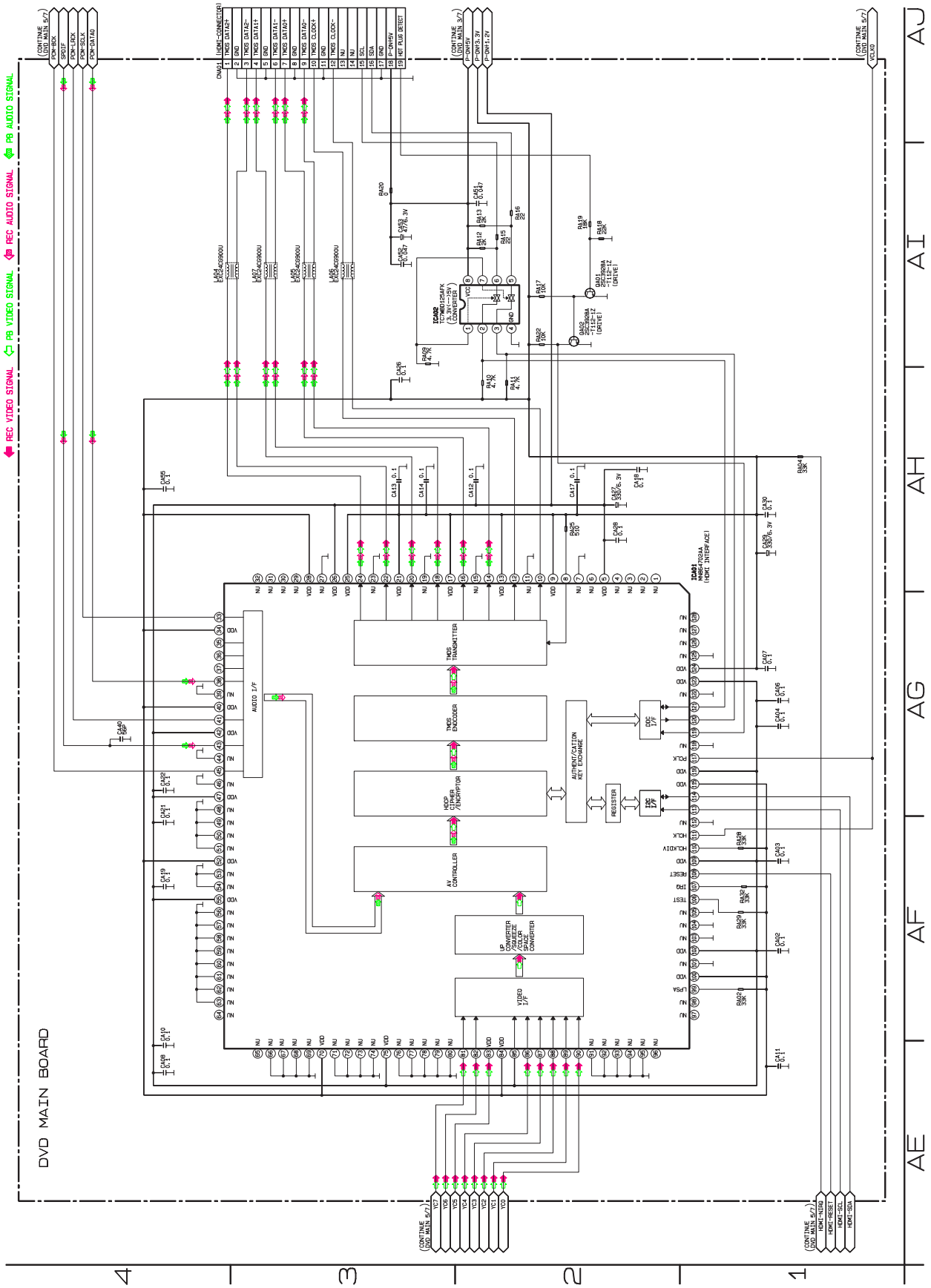

DVD MAIN 777 Schematic Diagram < DVD Section >

NOTE: BOARD MEANS PRINTED CIRCUIT BOARD.

*1 NOTE:
 The order of pins shown in this diagram is different from that of actual IC101.
 IC101 is divided into six and shown as IC101 (1/6) - IC101 (6/6) in this DVD Main Schematic Diagram Section.

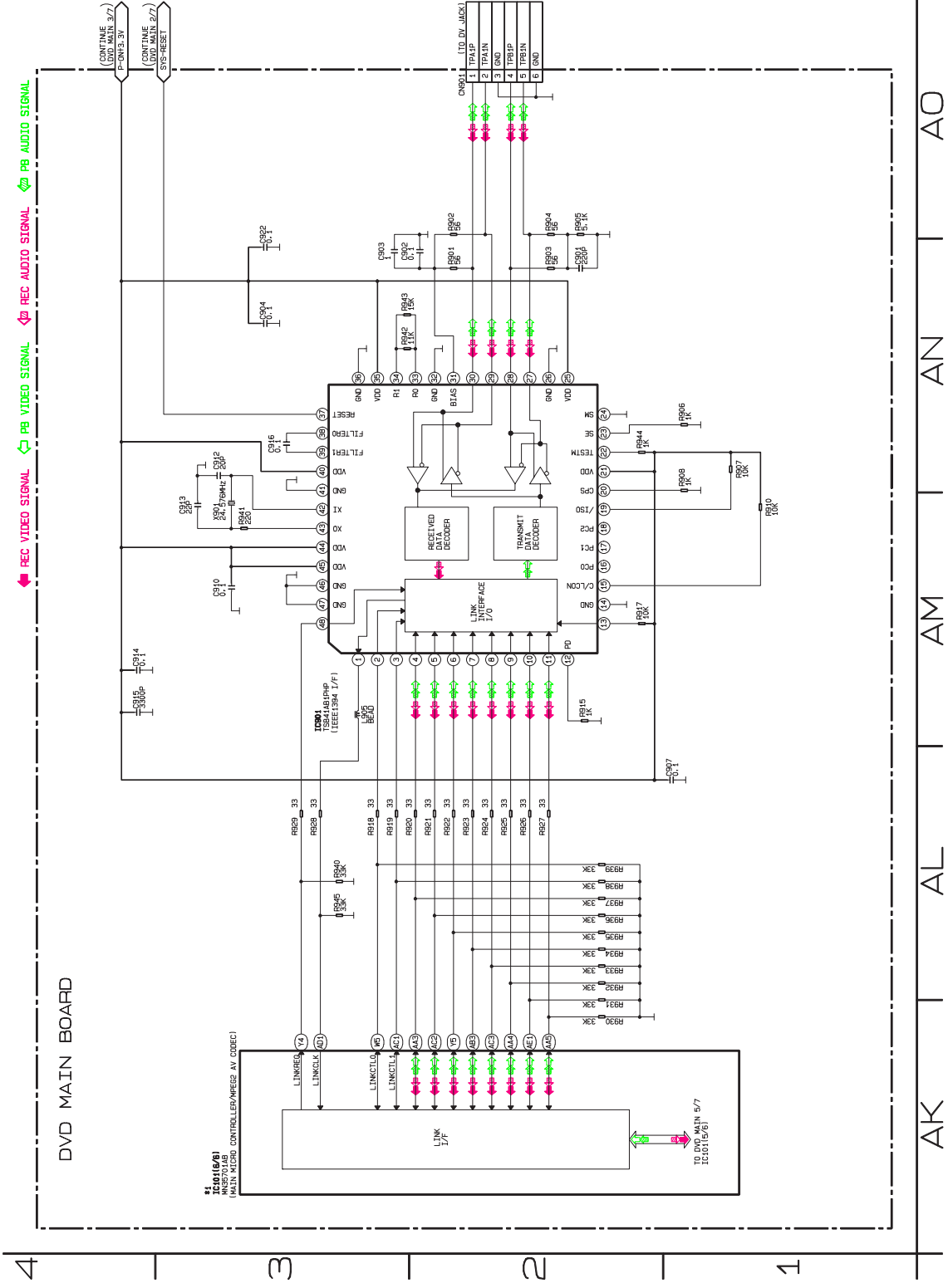

DTV MODULE UNIT Schematic Diagram

NOTE: BOARD MEANS PRINTED CIRCUIT BOARD.

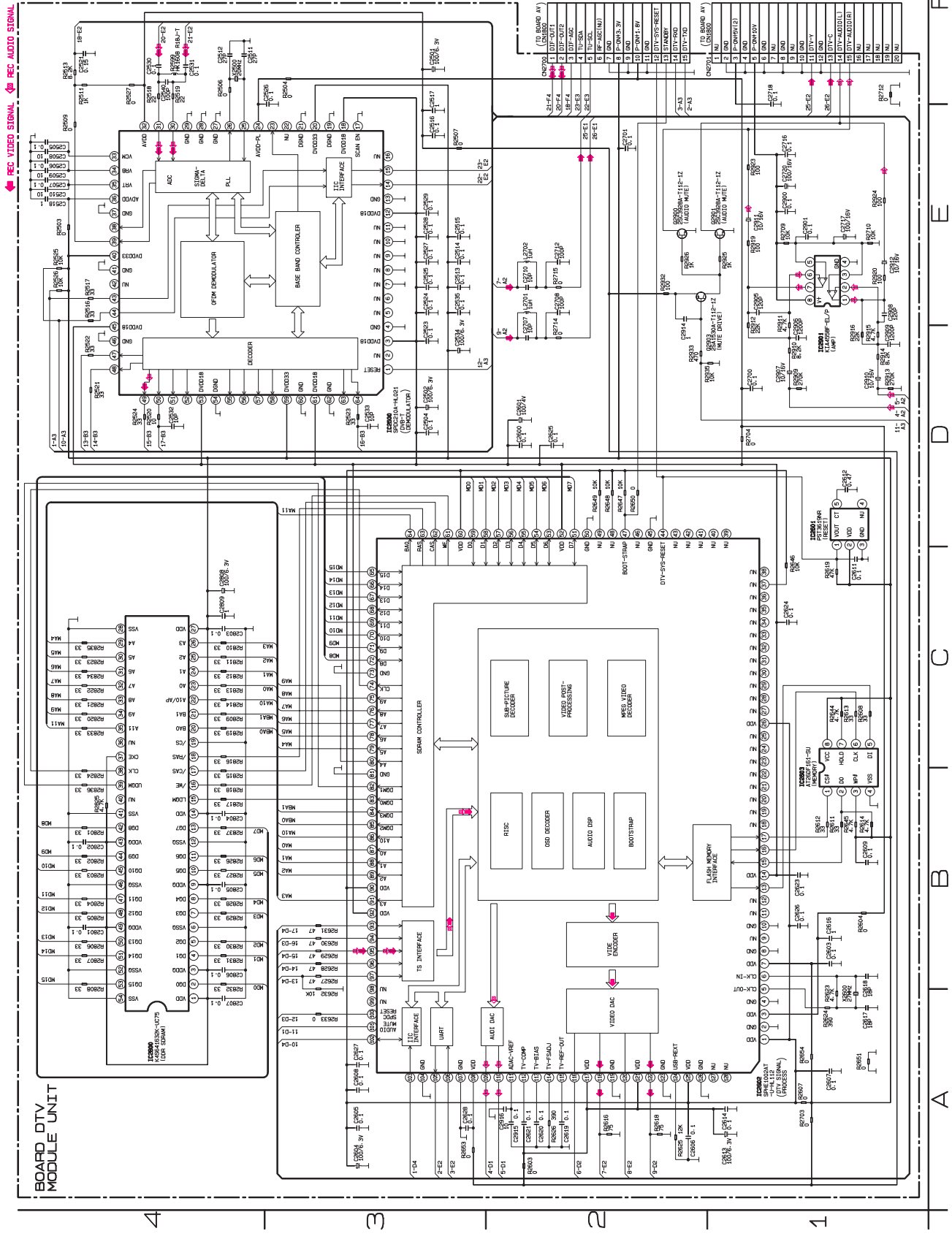

BOARD AV Top View

NOTE: BOARD MEANS PRINTED CIRCUIT BOARD.

BOARD SENSOR View

TO BOARD SENSOR
(END-SENSOR)

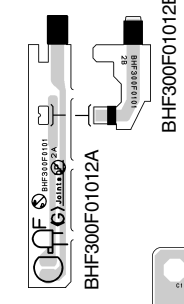

- WF3
- TP301
- C-PB
- WF2
- TP503
- CTL
- RF-SW
- VR501
- SW-POINT

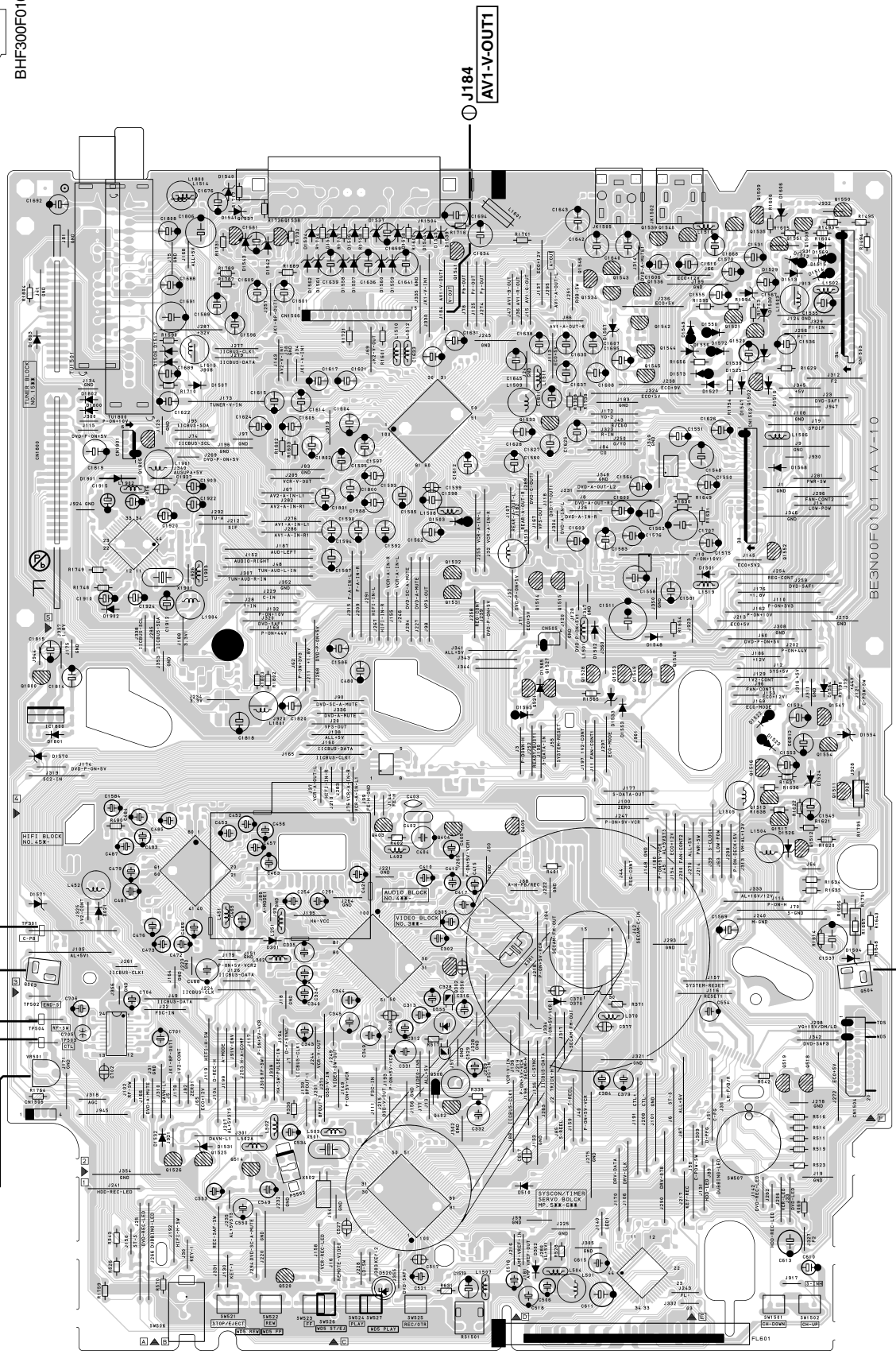

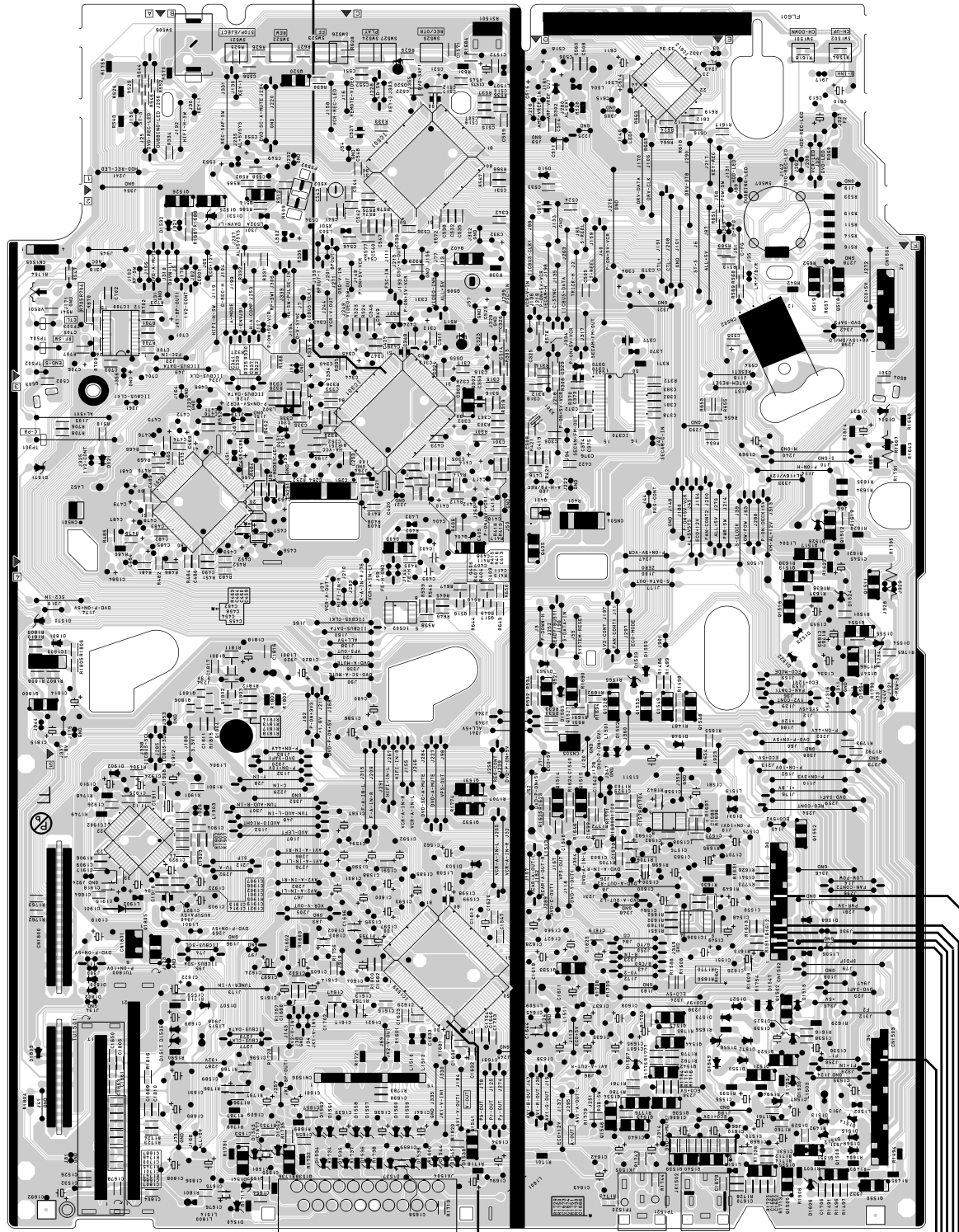

WF6
PIN 30 OF
IC1509

WF10
PIN 28 OF
CN1503

WF7
PIN 3 OF
CN1502

WF8
PIN 5 OF
CN1502

WF4
PIN 7 OF
CN1502

WF5
PIN 9 OF
CN1502

WF9
PIN 17 OF
CN1502

BOARD POWER SUPPLY Top View

NOTE: BOARD MEANS PRINTED CIRCUIT BOARD.

CAUTION !

For continued protection against fire hazard, replace only with the same type fuse.

CAUTION !

Fixed voltage (or Auto voltage selectable) power supply circuit is used in this unit. If Main Fuse (F1001) is blown, check to see that all components in the power supply circuit are not defective before you connect the AC plug to the AC power supply. Otherwise it may cause some components in the power supply circuit to fail.

Because a hot chassis ground is present in the power supply circuit, an isolation transformer must be used. Also, in order to have the ability to increase the input slowly, when troubleshooting this type power supply circuit, a variable isolation transformer is required.

NOTE:

The voltage for parts in hot circuit is measured using hot GND as a common terminal.

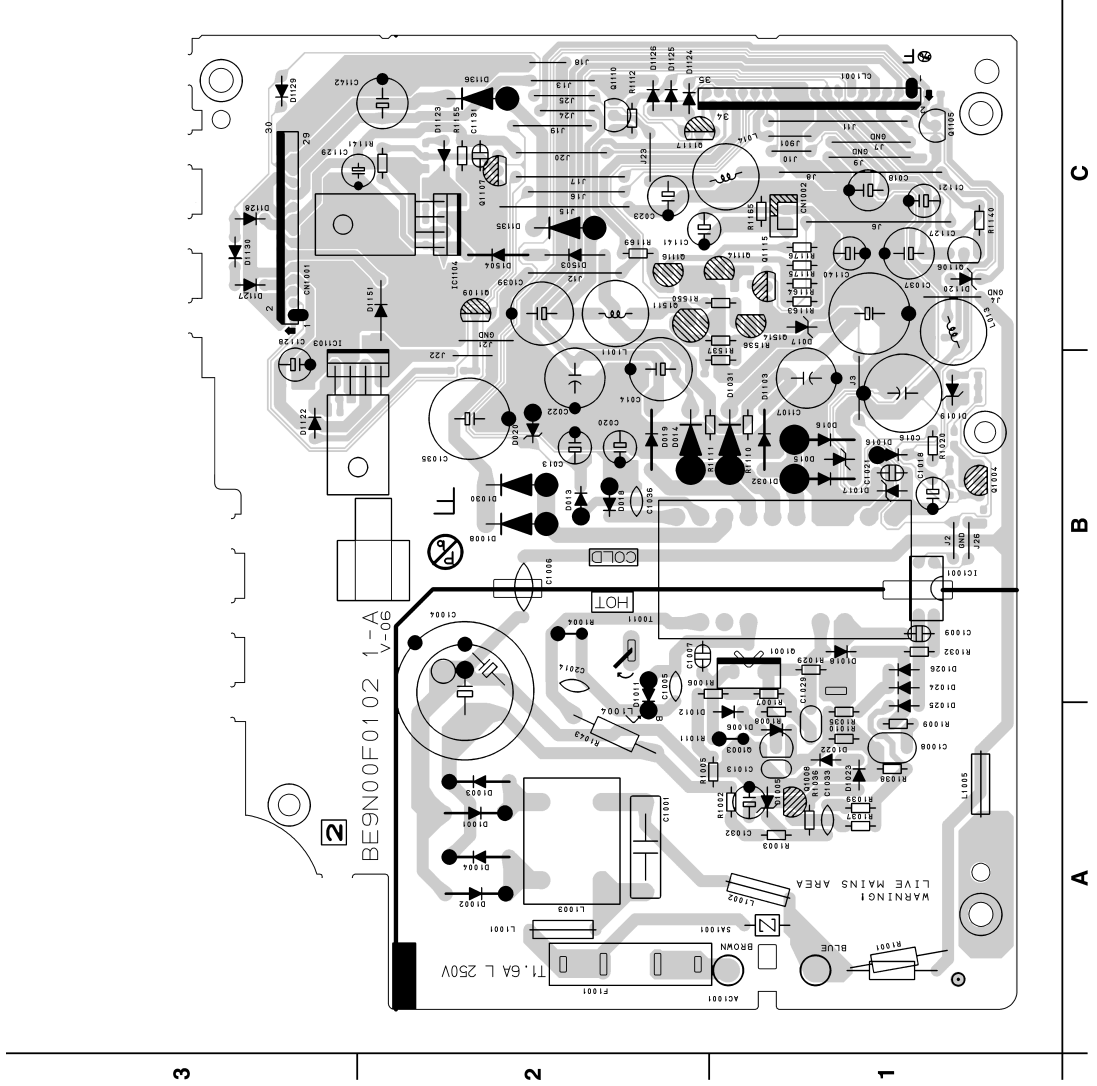

BOARD POWER SUPPLY Bottom View

NOTE: BOARD MEANS PRINTED CIRCUIT BOARD.

CAUTION !
For continued protection against fire hazard, replace only with the same type fuse.

CAUTION !
Fixed voltage (or Auto voltage selectable) power supply circuit is used in this unit. If Main Fuse (F1001) is blown, check to see that all components in the power supply circuit are not defective before you connect the AC plug to the AC power supply. Otherwise it may cause some components in the power supply circuit to fail.

Because a hot chassis ground is present in the power supply circuit, an isolation transformer must be used. Also, in order to have the ability to increase the input slowly, when troubleshooting this type power supply circuit, a variable isolation transformer is required.

NOTE:
The voltage for parts in hot circuit is measured using hot GND as a common terminal.

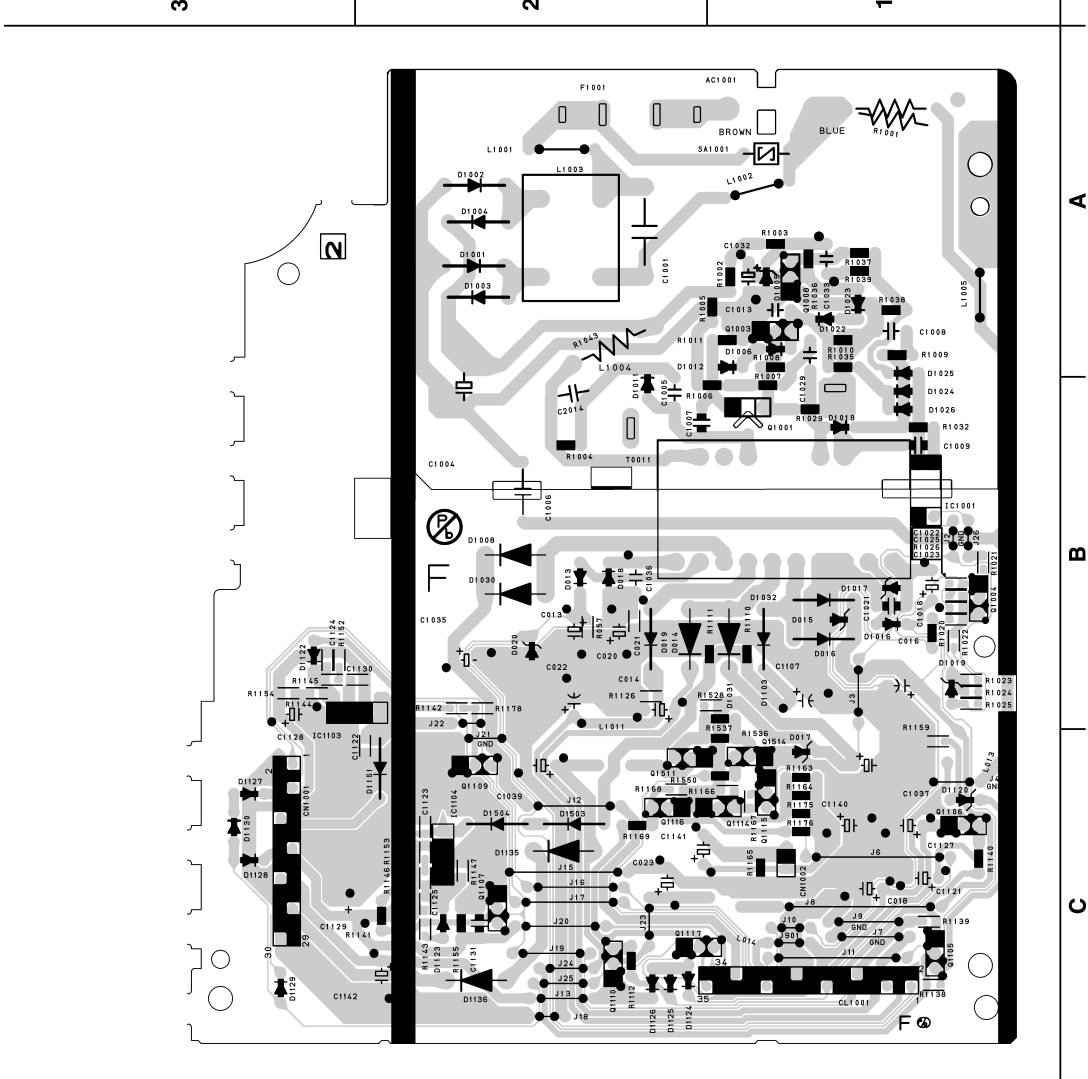

NOTE: BOARD MEANS PRINTED CIRCUIT BOARD.

BOARD POWER SWITCH
Top View

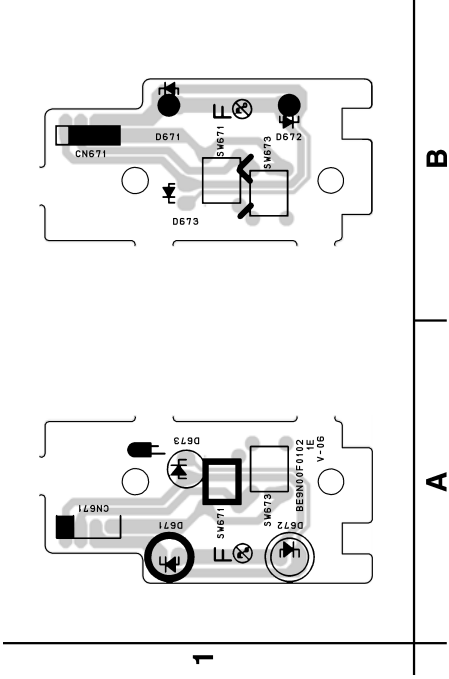

BOARD FUNCTION
Top View

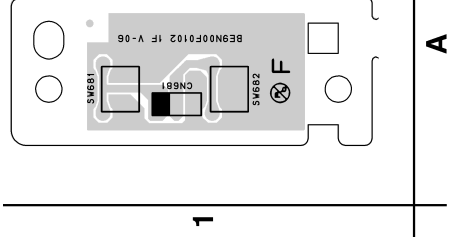

BOARD FUNCTION
Bottom View

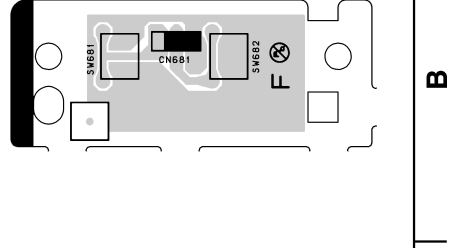

BE9N00F01021E

BE9N00F01021F

BOARD FRONT JACK
Top View

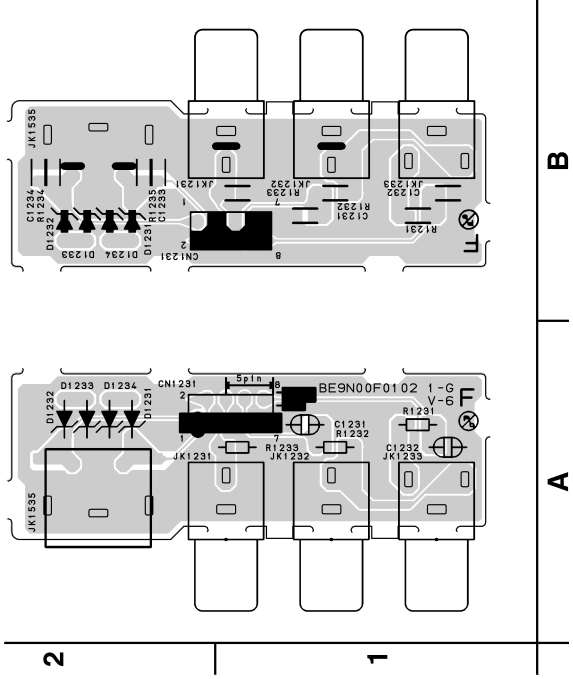

BOARD FRONT JACK
Bottom View

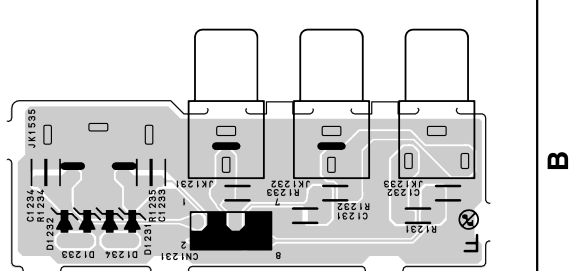

BE9N00F01021G

WAVEFORMS

NOTE:

Input: COLOR BAR SIGNAL (WITH 1KHz AUDIO SIGNAL)

WF1 Pin 56 of IC301

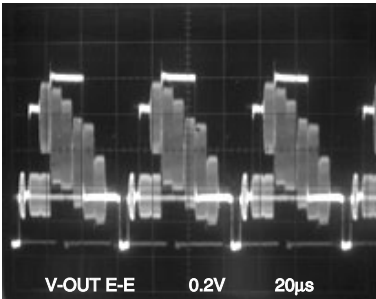

WF5 Pin 9 of CN1502

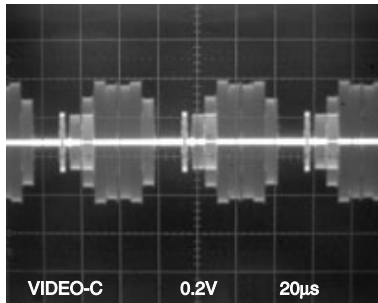

WF9 Pin 17 of CN1502

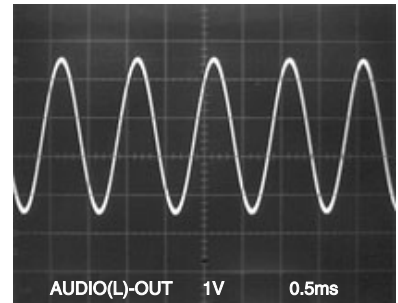

WF1 UPPER Pin 56 of IC301

WF2 LOWER TP504

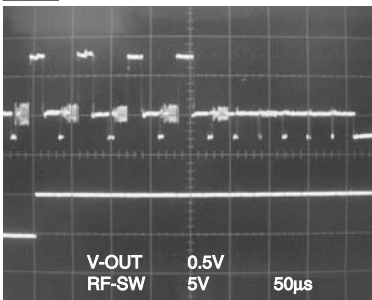

WF6 Pin 30 of IC1509

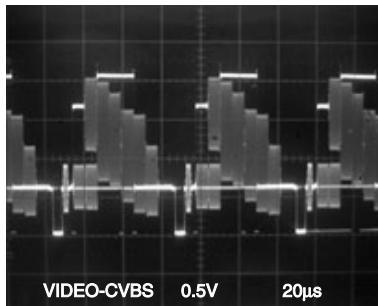

WF10 Pin 28 of CN1503

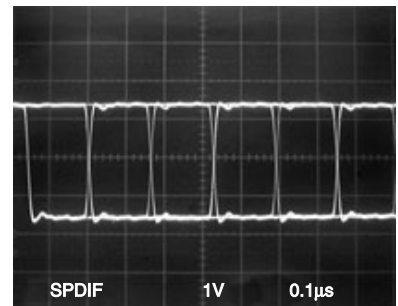

WF3 UPPER TP301

WF2 LOWER TP504

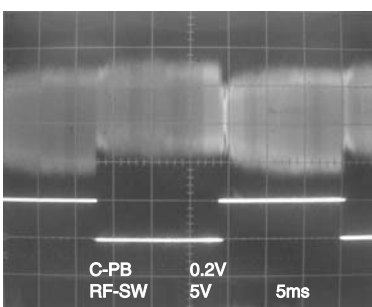

WF7 Pin 3 of CN1502

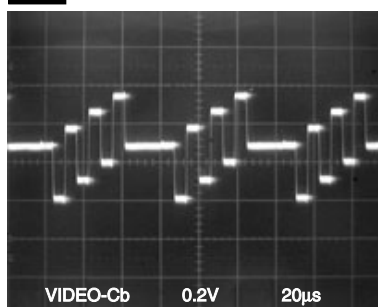

WF4 Pin 7 of CN1502

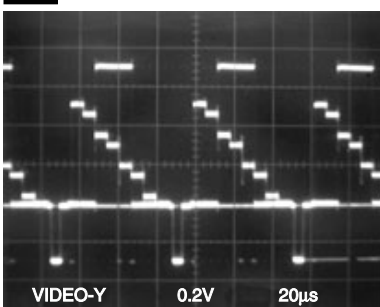

WF8 Pin 5 of CN1502

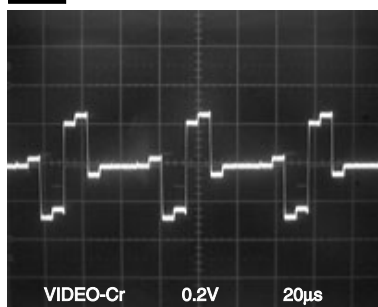

WIRING DIAGRAM

Wiring 1/2 Diagram

NOTE: BOARD MEANS PRINTED CIRCUIT BOARD.

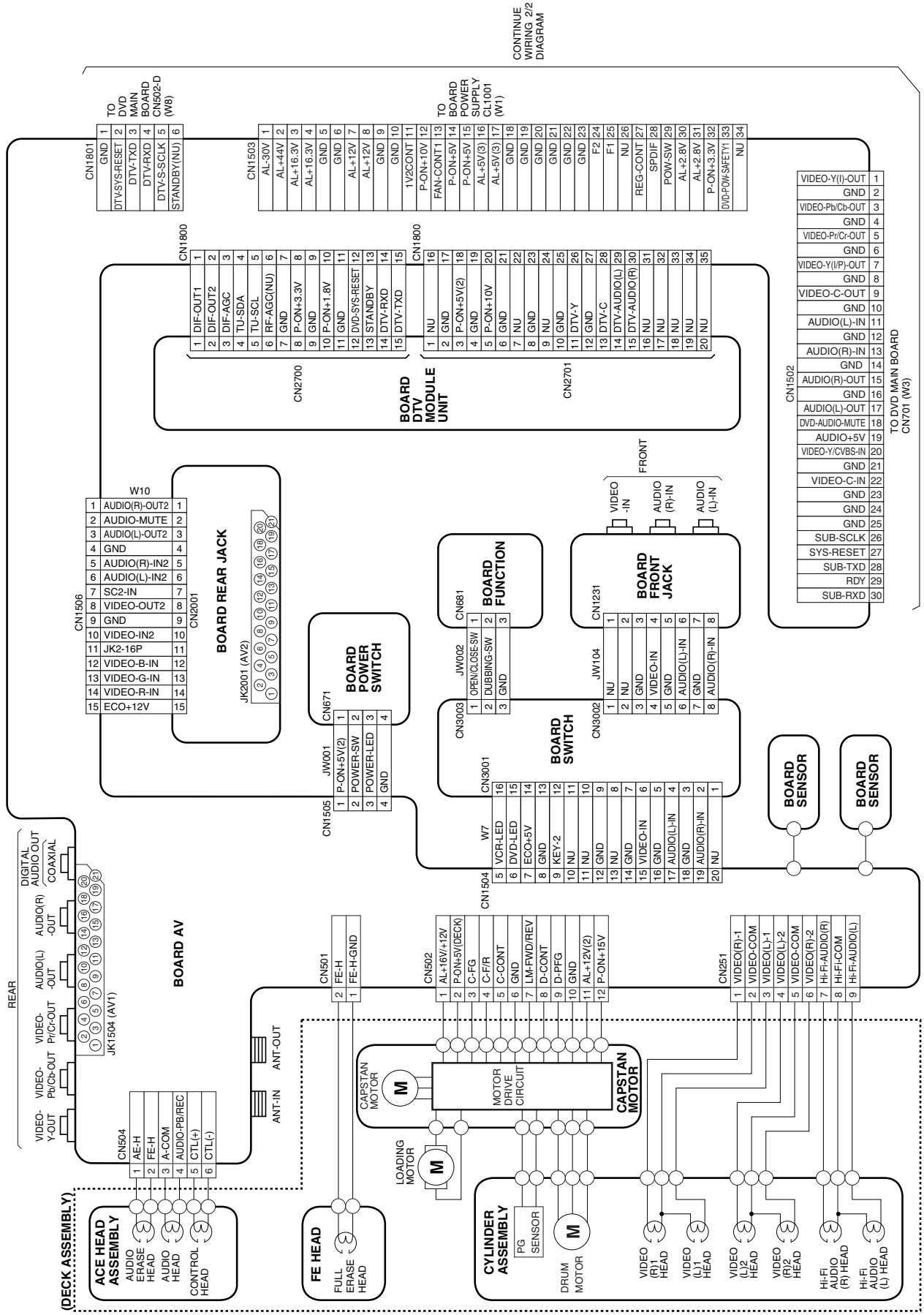

CONTINUE WIRING 2/2 DIAGRAM

Wiring 2/2 Diagram

NOTE: BOARD MEANS PRINTED CIRCUIT BOARD.

DVD MECHANISM & DVD MAIN BOARD ASSEMBLY

DVD MECHANISM

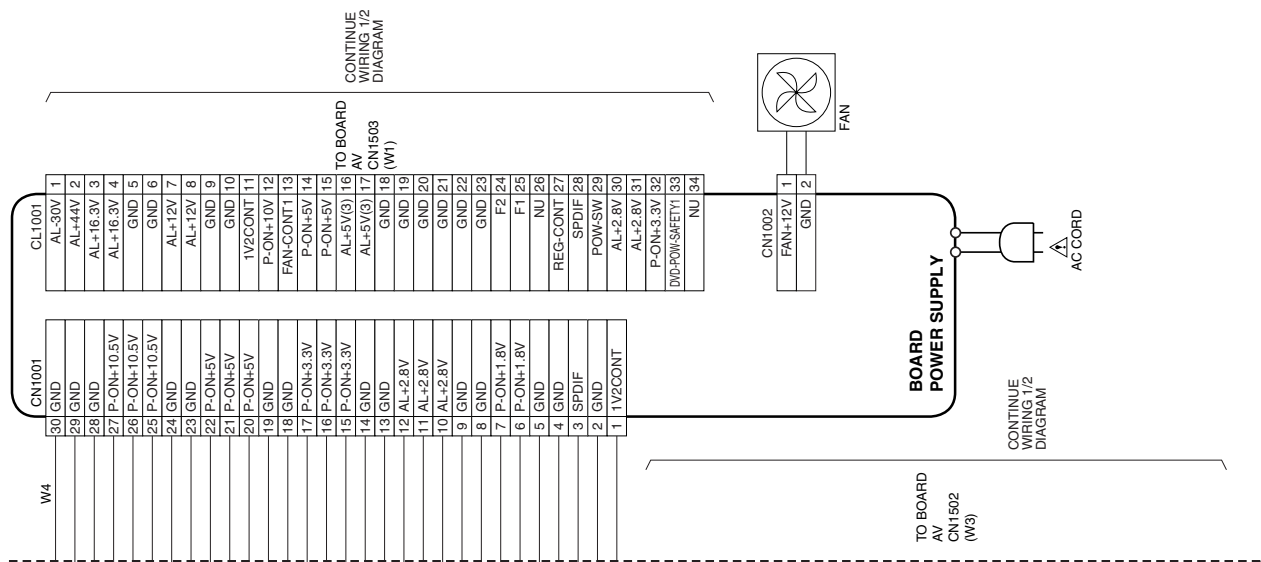
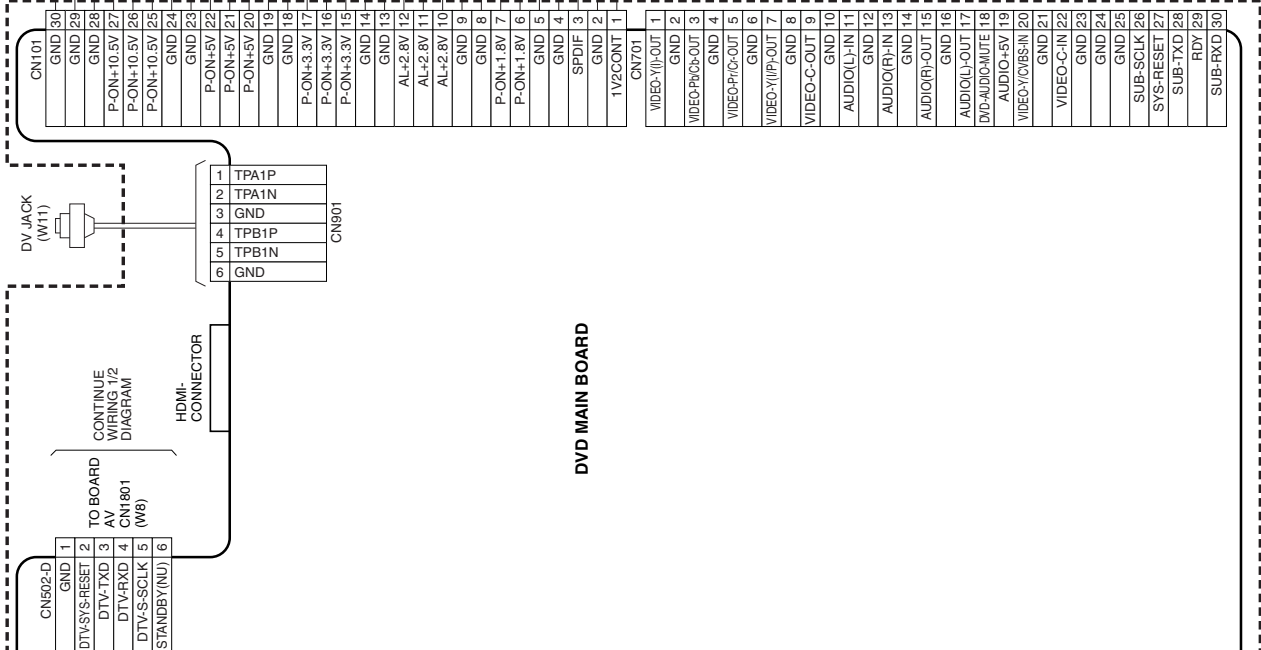
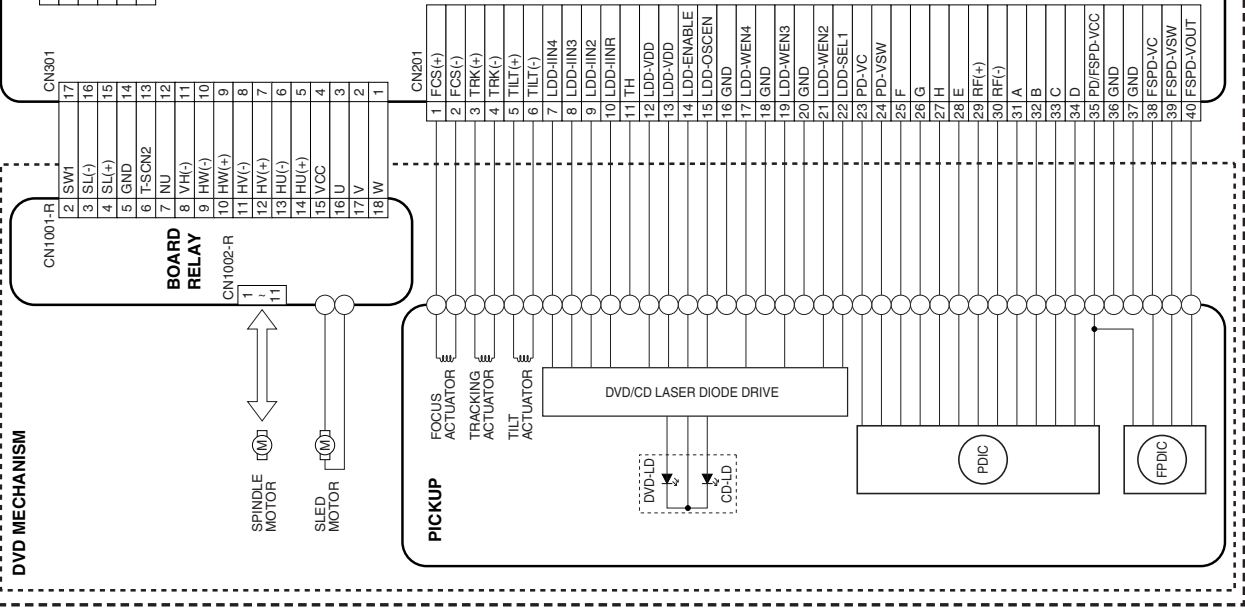

IC PIN FUNCTION DESCRIPTIONS

< VCR Section >

IC501 (SERVO / SYSTEM CONTROL)

Pin No.	IN/OUT	Signal Name	Function
1	IN	SC2-IN	Input Signal from Pin 8 of SCART2
2	IN	PG-DELAY	Video Head Switching Pulse Signal Adjusted Voltage
3	IN	DVD-POW-SAF	DVD P-ON Power Detection Input Signal
4	IN	END-S	Tape End Position Detect Signal
5	IN	AFC	Tuner Voltage Input Signal
6	IN	V-ENV	Video Envelope Comparator Signal
7	IN	KEY-1	Key Data Input 1
8	IN	KEY-2	Key Data Input 2
9	IN	LD-SW	Deck Mode Position Detector Signal
10	-	NU	Not Used
11	OUT	FAN-CONT1	Fan On Control Signal
12	-	NU	Not Used
13	OUT	D-V- SYNC	Dummy V-sync Output
14	IN	REMOTE	Remote Signal Input
15	OUT	C-ROTA	Color Phase Rotary Changeover Signal
16	OUT	H-A-SW	Video Head Amp Switching Pulse
17	IN	H-A-COMP	Head Amp Comparator Signal
18	OUT	RF-SW	Video Head Switching Pulse
19	OUT	Hi-Fi-H-SW	HiFi Audio Head Switching Pulse
20	-	NU	Not Used
21	-	NU	Not Used
22	-	NU	Not Used
23	-	NU	Not Used
24	-	NU	Not Used
25	OUT	1V2CONT	1.2V Regulator Control Signal
26	OUT	DVD-AUDIO-MUTE	DVD Audio Mute Control Signal (Mute="H")
27	OUT	VCR-AUDIO-MUTE	VCR Audio Mute Control Signal (Mute="H")

Pin No.	IN/OUT	Signal Name	Function
28	IN	A-MODE	Hi-Fi Tape Defection Signal
29	OUT	AUDIO-MUTE	Audio Mute Control Signal (Mute="H")
30	OUT	SC-AUDIO-MUTE	SCART Jack Audio Mute Control Signal (Mute="H")
31	IN	REC-SAF-SW	Recording Safety SW Detect (With Record tab="L"/ With out Record tab="H")
32	IN	P-DOWN-H	Power Voltage Down Detector Signal
33	OUT	D-REC-H	Delayed Record Signal
34	IN	RESET	Micro Controller Reset Signal
35	IN	Xcin	Sub Clock Input
36	OUT	Xcout	Sub Clock Output
37	-	Vcc	Always +5V with AC Plug Connected
38	IN	Xin	Main Clock Input
39	OUT	Xout	Main Clock Output
40	-	Vss	Ground
41	-	8POUT-1	Control SCART1 8Pin Level by using 8POUT-1
42	-	8POUT-2	Control SCART2 8Pin Level by using 8POUT-2
43	IN	CLKSEL	Clock Select
44	IN	OSCin	Clock Input for letter size
45	OUT	OSCout	Clock Output for letter size
46	-	NU	Ground
47	IN	LP	LP
48	IN	FSC-IN [4.43MHz]	4.43MHz Clock Input
49	-	OSDVss	Ground
50	IN	OSD-V-IN	OSD Video Signal Input
51	-	NU	Not Used
52	OUT	OSD-V-OUT	OSD Video Signal Output
53	-	OSDVcc	+5V Power Supply (OSD)
54	-	HLF	LPF Connected Terminal (Slicer)
55	IN	COLOR-IN	SECAM or MESECAM Chroma Video Input Signal at Super Impose
56	-	DAVN-L	VPS/PDC Data (Receive="L")
57	-	NU	Ground

Pin No.	IN/OUT	Signal Name	Function
58	IN	C-SYNC	Composite Synchronized Pulse
59	OUT	POW-SW	Power Switching Signal
60	OUT	REG-CONT	Power Regulator Control Signal
61	IN	SECAM-H	SECAM Mode at High
62	OUT	TRICK-H	Special playback = "H" in SECAM Mode
63	OUT	SYS-RESET	System Reset Signal
64	IN	RDY	Ready/Busy Communication Control with Main Micro Controller
65	OUT	SUB-TXD	Transmission Data to Main Micro Controller
66	IN	SUB-RXD	Reception Data from Main Micro Controller
67	OUT	SUB-SCLK	Communication Clock with Main Micro Controller
68	OUT	DRV-DATA	VFD Driver IC Control Data
69	OUT	DRV-STB	VFD Driver IC Chip Select Signal
70	OUT	DRV-CLK	VFD Driver IC Control Clock
71	OUT	IIC-BUS SCL	IIC BUS Serial Clock
72	IN/OUT	IIC-BUS SDA	IIC BUS Serial Data
73	-	NU	Not Used
74	-	NU	Not Used
75	OUT	P-ON-H	Power On Signal to High
76	OUT	C-CONT	Capstan Motor Control Signal
77	OUT	D-CONT	Drum Motor Control Signal
78	OUT	C-F/R	Capstan Motor FWD/REV Control Signal (FWD="L"/REV="H")
79	IN	S-REEL	Supply Reel Rotation Signal
80	IN	T-REEL	Take Up Reel Rotation Signal
81	OUT	LM-FWD/REV	Loading Motor Control Signal
82	OUT	C-POW-SW	Capstan Power Switching Signal
83	IN	DVD-POW-SAFETY3	DVD P-ON Power Defection Input Signal 3
84	-	NU	Not Used
85	-	NU	Not Used
86	IN	VCR-POW-SAFETY	VCR P-ON Power Defection Input Signal
87	IN	C-FG	Capstan Motor Rotation Detection Pulse

Pin No.	IN/OUT	Signal Name	Function
88	-	AMPVss	Ground
89	IN	DVD-POW-SAFETY2	DVD P-ON Power Defection Input Signal2
90	IN	D-PFG	Drum Motor Phase/Frequency Generator
91	-	AMPVREF out	V-Ref for CTL AMP
92	-	AMPVREF in	V-Ref for CTL AMP
93	-	P80/C	P80/C Terminal
94	IN/OUT	CTL (-)	Playback/Record Control Signal (-)
95	IN/OUT	CTL (+)	Playback/Record Control Signal (+)
96	-	AMPC	CTL AMP Connected Terminal
97	-	CTL	To Monitor for CTL AMP Output
98	-	AMPVcc	Always +5V with AC Plug Connected
99	-	AVcc	Always +5V with AC Plug Connected
100	IN	ST-S	Tape Start Position Defector Signal

IC612 (VFD DRIVER)

Pin No.	IN/ OUT	Signal Name	Function
1	OUT	POWER-LED	POWER-LED Control Signal
2	OUT	DVD-LED	DVD-LED Control Signal
3	OUT	VCR-LED	VCR-LED Control Signal
4	-	NU	Not Used
5	IN	OSC	Oscillator Input
6	-	NU	Not Used
7	IN	DRV-DIN	Serial Data Input
8	IN	DRV-CLK	Serial Clock Input
9	IN	DRV-STB	Serial Interface Input
10	-	NU	Not Used
11	-	NU	Not Used
12	-	VSS	Ground
13	-	VDD	Power Supply
14	-	NU	Not Used
15	-	NU	Not Used
16	-	NU	Not Used
17	-	NU	Not Used
18	-	NU	Not Used
19	-	NU	Not Used
20	OUT	P1	Segment Output Serial Data Input
21	OUT	P8	
22	OUT	P9	
23	OUT	P2	
24	OUT	P3	
25	OUT	P4	
26	OUT	P7	
27	OUT	P6	
28	OUT	P5	
29	-	NU	Not Used
30	-	VEE	Pull Down Level
31	-	NU	Not Used
32	-	NU	Not Used
33	-	NU	Not Used
34	-	NU	Not Used
35	-	NU	Not Used
36	OUT	7G	Grid Output
37		6G	
38		5G	
39		4G	
40		3G	
41		2G	
42		1G	
43	-	VDD	Power Supply

Pin No.	IN/ OUT	Signal Name	Function
44	-	VSS	Ground

LEAD IDENTIFICATIONS

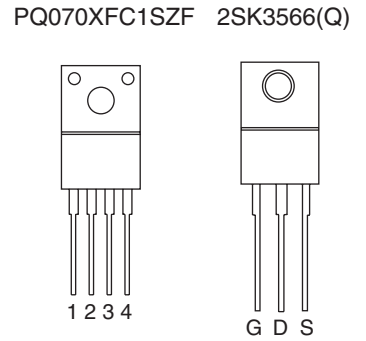
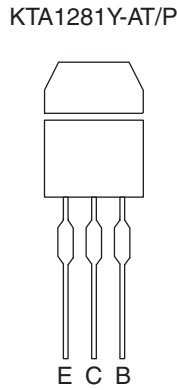
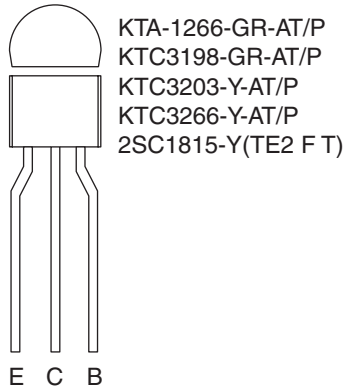
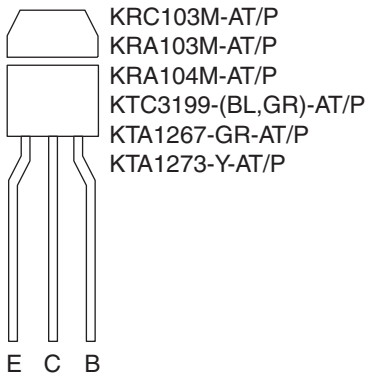

KTK5132S-RTK/P

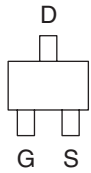

KRC103S-RTK/P
2SC3928A-T112-1R
2SC3928A-T112-1Z

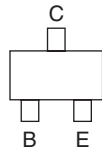

KIA4558F-EL/P

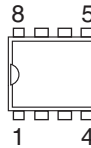

PT204-6B-12



LA72648M-MPB-E

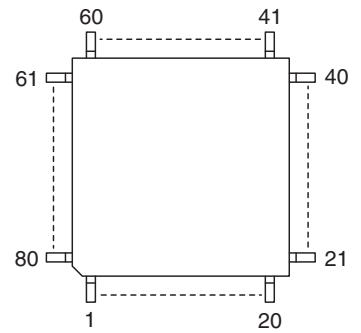

UTC4580E

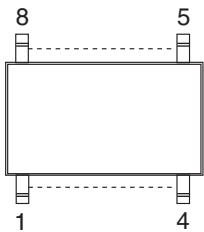

LA70100M-TRM-E

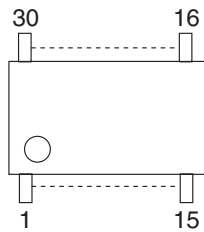

LC74793JM-TLM-E

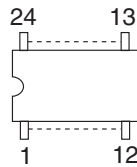

RN1511(TE85R.F)

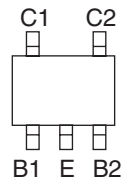

PS2561A-1(W)

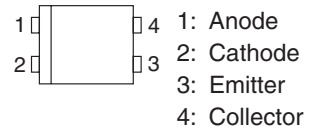

MSP3417G-QG-B8-V3
PT6315(L)

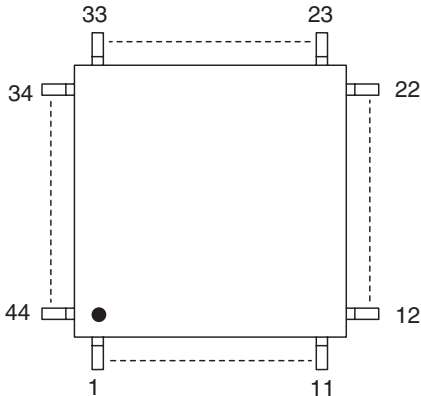

HA118326APF-E
LA71750EM-MPB-E
M3776AMCH-AH1GP

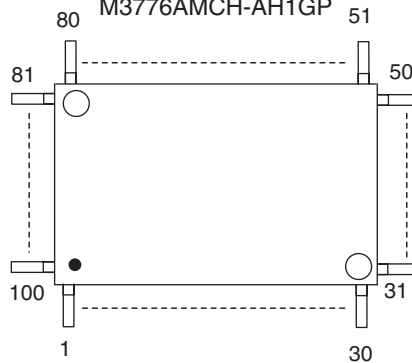

Note:

- A: Anode
- K: Cathode
- E: Emitter
- C: Collector
- B: Base
- R: Reference
- G: Gate
- D: Drain
- S: Source

EXPLODED VIEWS

Cabinet

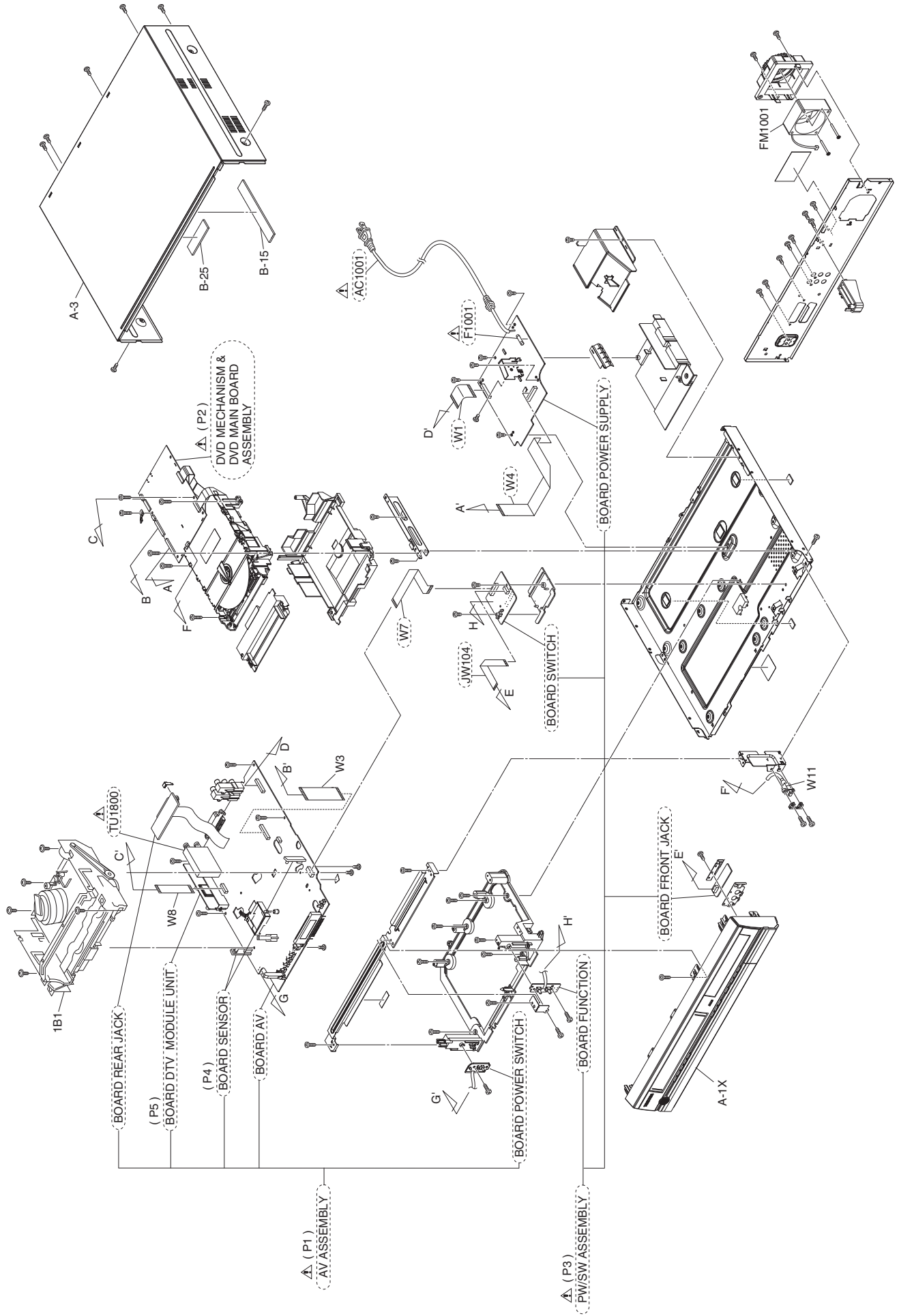

(P1) AV ASSEMBLY

(P4) BOARD SENSOR

(P5) BOARD DTV MODULE UNIT

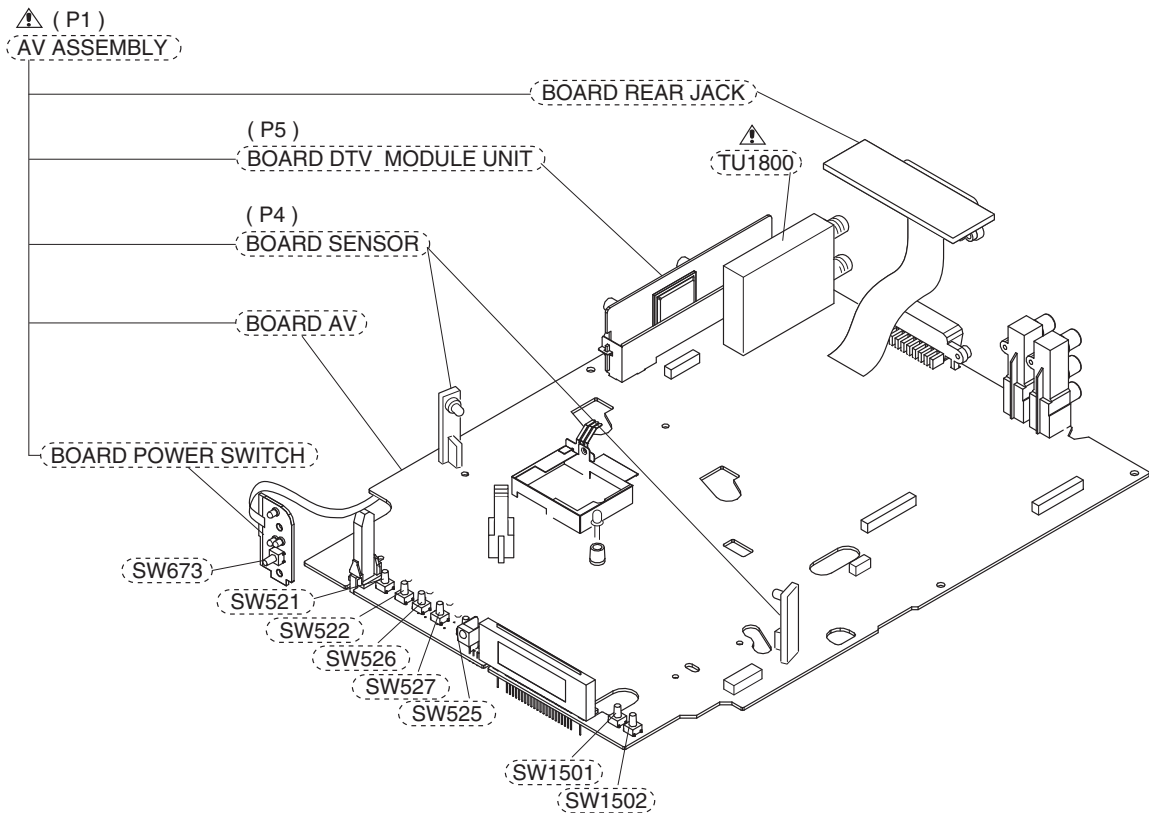

(P3) PW/SW ASSEMBLY

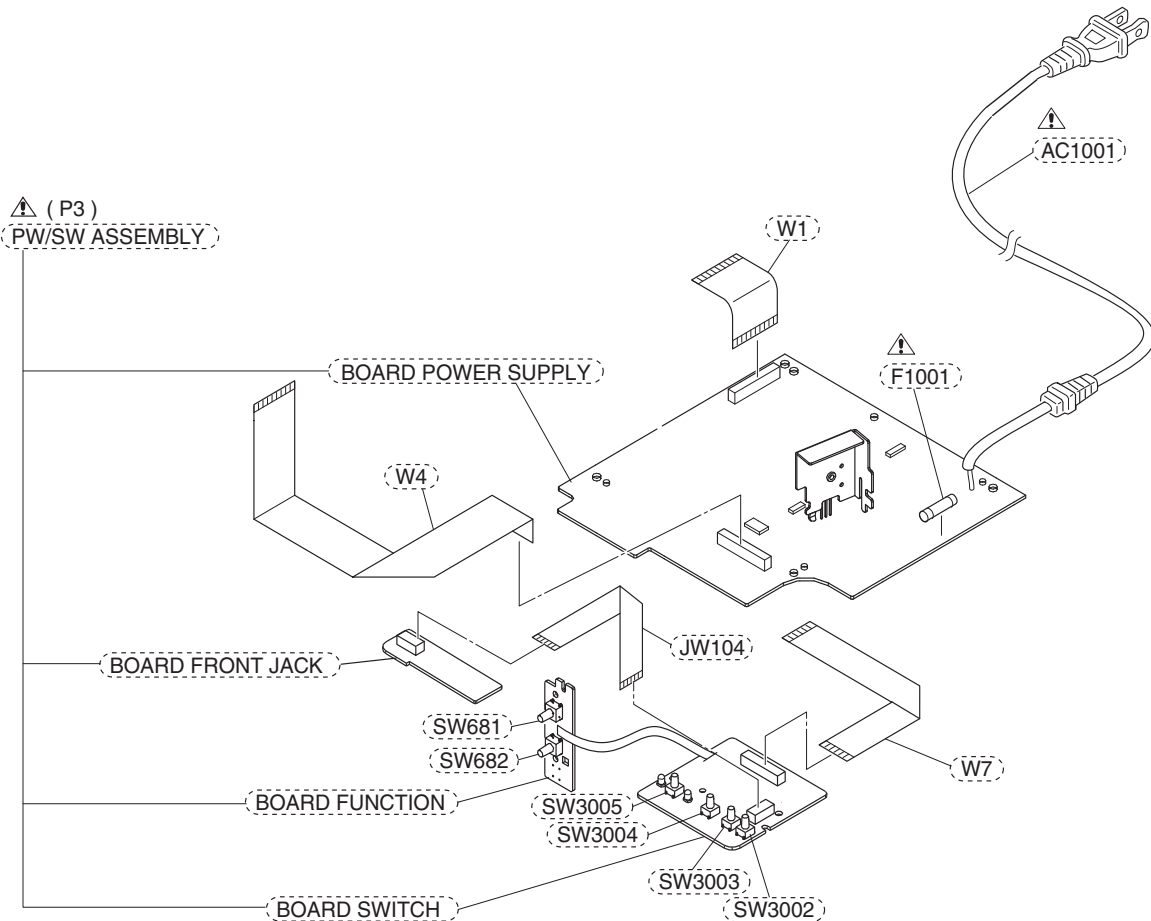

(P2) DVD MECHANISM & DVD MAIN BOARD ASSEMBLY

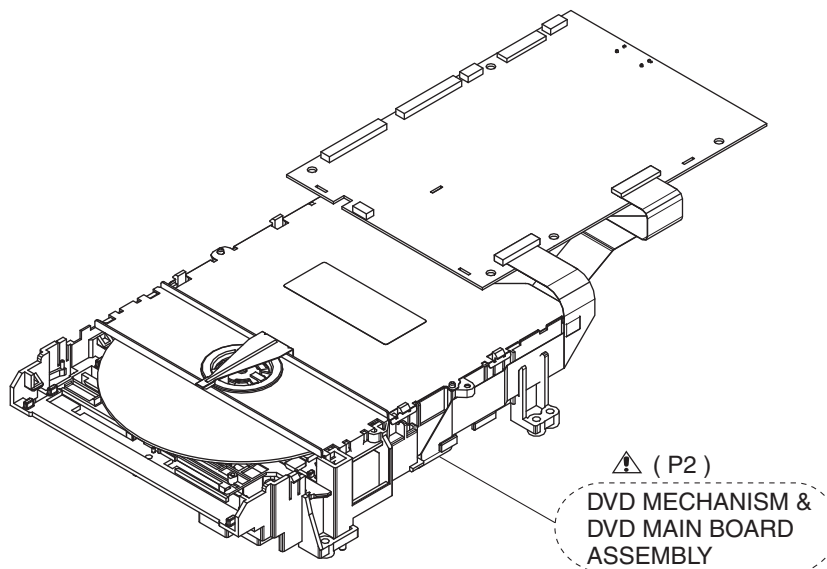

Packing

Lower Side → Upper Side

X-6 ▲ X-2D ▲ X-2C

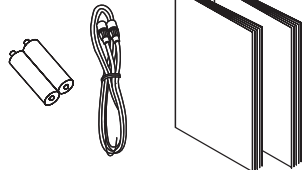

Lower Side → Upper Side

▲ X-2A ▲ X-2B ▲ X-2E X-3

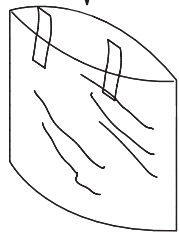
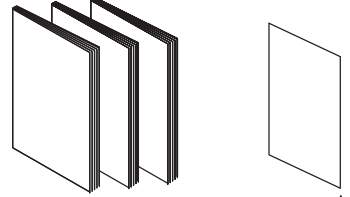

X1

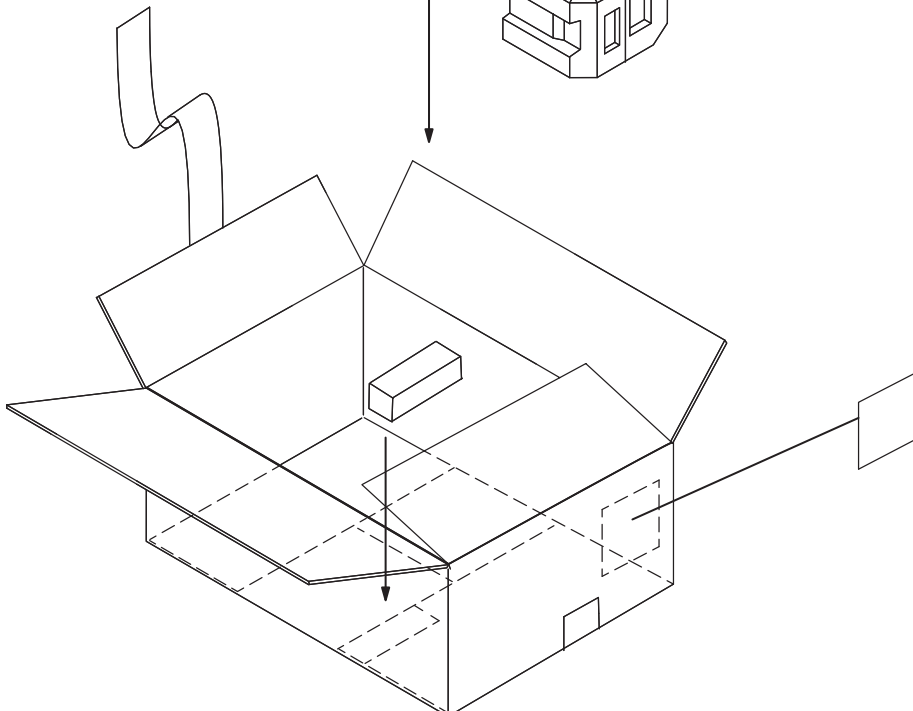
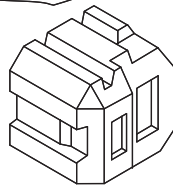
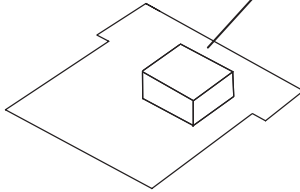
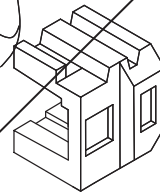
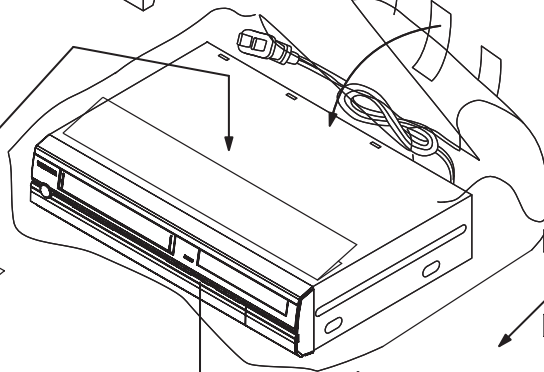
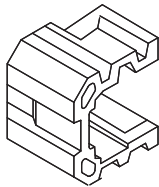
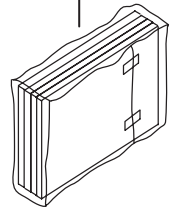
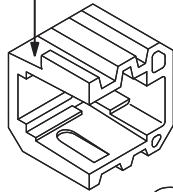
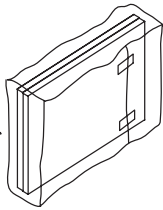
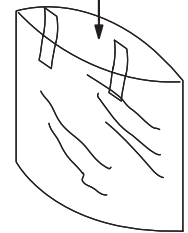
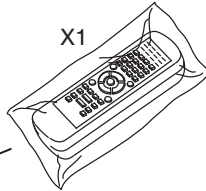

MECHANICAL PARTS LIST

PRODUCT SAFETY NOTE: Products marked with a  have special characteristics important to safety. Before replacing any of these components, read carefully the product safety notice in this service manual. Don't degrade the safety of the product through improper servicing.

	Location No.	TSB P/N	Reference No.	Description
	A-1X	P000502370	1VM121699	PANEL FRONT E9NG0FD
	A-3	P000502120	1VM323985	COVER TOP(H-BLACK) E3HE0JD
	1B1	P000472770	N25E1FL	DECK ASSEMBLY CZD014/ VM25E0
	B-15	P000502130	1VM427939	CUSHION RUBBER (TOP BOARD ASSEMBLY E3NG0FD)
	B-25	P000502100	0VM416664C	CUSHION RUBBER E9400UD
	FM1001	P000502230	MMEZR12XNR04	MOTOR DC FAN 2D65BK100230
	W3	P000502310	WX1E3N00-003	WIRE ASSY 30PIN FFC WX1E3N00-003
	W8	P000502330	WX1E3N00-006	WIRE ASSY 6PIN FFC WX1E3N00- 006
	W11	P000502280	WPZ0331WJ001	IEEE1394 CABLE JE-1710-9
ACCESSORIES				
	X1	P000502490	NB348ED	REMOTE CONTROL UNIT NB348ED
	X-2A	P000502380	1VMN25059	OWNERS MANUAL(EN) E9NG0FD
	X-2B	P000502390	1VMN25060	OWNERS MANUAL(FR) E9NG0FD
	X-2C	P000502400	1VMN25061	OWNERS MANUAL(IT) E9NG0FD
	X-2D	P000502410	1VMN25062	OWNERS MANUAL(DE) E9NG0FD
	X-2E	P000502420	1VMN25063	OWNERS MANUAL(ES) E9NG0FD
	X-3	P000502430	1VMN25064	QUICK GUIDE E9NG0FD
	X-6	P000460030	WPZ0122LG001	RF CORD PAL 1.2M

ELECTRICAL PARTS LIST

PRODUCT SAFETY NOTE: Products marked with a \triangle have special characteristics important to safety. Before replacing any of these components, read carefully the product safety notice in this service manual. Don't degrade the safety of the product through improper servicing.

NOTES:

- Parts that are not assigned part numbers (-----) are not available.
- Tolerance of Capacitors and Resistors are noted with the following symbols.

C..... \pm 0.25% D..... \pm 0.5% F..... \pm 1%
 G..... \pm 2% J..... \pm 5% K..... \pm 10%
 M..... \pm 20% N..... \pm 30% Z.....+80/-20%

DVD MECHANISM & DVD MAIN BOARD ASSEMBLY

\triangle	Location No.	TSB P/N	Reference No.	Description
\triangle	P2	P000502480	N78EFEFN	DVD MECHANISM & DVD MAIN BOARD ASSEMBLY

AV ASSEMBLY

\triangle	Location No.	TSB P/N	Reference No.	Description
\triangle	P1	P000502440	(Not Available)	AV ASSEMBLY Consists of the following
	P4	P000472720	1VSA13519	BOARD AV
	P5	P000502200	1VSA17345	BOARD SENSOR BOARD DTV MODULE UNIT BOARD REAR JACK BOARD POWER SWITCH

BOARD AV

\triangle	Location No.	TSB P/N	Reference No.	Description
		-----	-----	BOARD AV
Following parts are included in BOARD AV.				
	SW521	P000483300	SST0101AL041	TACT SWITCH SKQSAF001A
	SW522	P000483300	SST0101AL041	TACT SWITCH SKQSAF001A
	SW525	P000483300	SST0101AL041	TACT SWITCH SKQSAF001A
	SW526	P000483300	SST0101AL041	TACT SWITCH SKQSAF001A
	SW527	P000483300	SST0101AL041	TACT SWITCH SKQSAF001A
	SW1501	P000483300	SST0101AL041	TACT SWITCH SKQSAF001A
	SW1502	P000483300	SST0101AL041	TACT SWITCH SKQSAF001A
\triangle	TU1800	P000502270	UTUNDTVMS004	TUNER UNIT ENGF7710KF

BOARD SENSOR

\triangle	Location No.	TSB P/N	Reference No.	Description
	P4	P000472720	1VSA13519	BOARD SENSOR

BOARD DTV MODULE UNIT

\triangle	Location No.	TSB P/N	Reference No.	Description
	P5	P000502200	1VSA17345	BOARD DTV MODULE UNIT

BOARD POWER SWITCH

\triangle	Location No.	TSB P/N	Reference No.	Description
		-----	-----	BOARD POWER SWITCH
Following part is included in BOARD POWER SWITCH.				
	SW673	P000483300	SST0101AL041	TACT SWITCH SKQSAF001A

PW/SW ASSEMBLY

\triangle	Location No.	TSB P/N	Reference No.	Description
\triangle	P3	P000502450	(Not Available)	PW/SW ASSEMBLY Consists of the following
		-----	-----	BOARD POWER SUPPLY
		-----	-----	BOARD SWITCH
		-----	-----	BOARD FUNCTION
		-----	-----	BOARD FRONT JACK

BOARD POWER SUPPLY

\triangle	Location No.	TSB P/N	Reference No.	Description
		-----	-----	BOARD POWER SUPPLY
Following parts are included in BOARD POWER SUPPLY.				
\triangle	C1001	P000493460	CT2E683DC016	ACROSS THE LINE CAP. 0.068 μ F/250V
\triangle	C1006	P000493450	CCN2EMA0E222	SAFETY CAP. 2200pF/250V
\triangle	IC1001	P000483270	QPEWPS2561A1	PHOTOCOUPLER PS2561A-1(W)
\triangle	L1003	P000502460	LLEG0Z0Y2025	COIL LINE FILTER ST0703FT20-036 53MH
\triangle	Q1001	P000502500	QFWZ02SK3566	FET 2SK3566(Q)
\triangle	R1001	P000493510	RXX2565MGL01	GLASS GLAZE RES. 1/2W J 5.6M Ω
\triangle	AC1001	P000468380	WAE0172LW011	POWER CORD PE8G2CG9G0AB05
\triangle	F1001	P000491500	PDGJAB0NG162	FUSE TIME RAG FSL250V1.6A(EM)
\triangle	SA1001	P000457210	NVQZ10D471KB	SURGE ABSORBER 470V+ 10PER
\triangle	T0011	P000502470	LTT2PE0KT034	TRANS POWER 8714
	W1	P000502290	WX1E3N00-001	WIRE ASSEMBLY 34PIN FFC WX1E3N00-001
	W4	P000502510	WX1E9N00-001	WIRE ASSEMBLY 30PIN FFC WX1E9N00-001

BOARD SWITCH

\triangle	Location No.	TSB P/N	Reference No.	Description
		-----	-----	BOARD SWITCH
Following parts are included in BOARD SWITCH.				
	SW3002	P000483300	SST0101AL041	TACT SWITCH SKQSAF001A
	SW3003	P000483300	SST0101AL041	TACT SWITCH SKQSAF001A
	SW3004	P000483300	SST0101AL041	TACT SWITCH SKQSAF001A
	SW3005	P000483300	SST0101AL041	TACT SWITCH SKQSAF001A
	JW104	P000465670	WX1E9700-002	FFC CABLE 8P FFC/P1.25/120
	W7	P000502520	WX1E9N00-002	WIRE ASSEMBLY 16PIN FFC WX1E9N00-002

BOARD FUNCTION

\triangle	Location No.	TSB P/N	Reference No.	Description
		-----	-----	BOARD FUNCTION
Following parts are included in BOARD FUNCTION.				
	SW681	P000483300	SST0101AL041	TACT SWITCH SKQSAF001A
	SW682	P000483300	SST0101AL041	TACT SWITCH SKQSAF001A

DECK MECHANISM SECTION

DVD VIDEO RECORDER / VIDEO CASSETTE RECORDER

D-VR60DTKF

Deck Mechanism Section

- Standard Maintenance
- Mechanism Alignment Procedures
- Disassembly / Assembly of Mechanism
- Deck Exploded Views
- Deck Parts List

TABLE OF CONTENTS

Standard Maintenance	2-1-1
Service Fixture and Tools	2-2-1
Mechanical Alignment Procedures	2-3-1
Disassembly / Assembly Procedures of Deck Mechanism	2-4-1
Alignment Procedures of Mechanism	2-5-1
Deck Exploded Views	2-6-1

STANDARD MAINTENANCE

Service Schedule of Components

This maintenance chart shows you the standard of replacement and cleaning time for each part. Because those may replace depending on environment and purpose for use, use the chart for reference.

h: Hours ○: Cleaning ●: Replace

Deck		Periodic Service Schedule			
Ref.No.	Part Name	1,000 h	2,000 h	3,000 h	4,000 h
B2	Cylinder Assembly	○	●	○	●
B3	Loading Motor Assembly			●	
B8	Pulley Assembly		●		●
B587	Tension Lever Assembly		●		●
B31	ACE Head Assembly			●	
B573, B574	Reel S, Reel T			●	
B37	Capstan Motor		●		●
B52	Cap Belt		●		●
B73	FE Head			●	
B86	F Brake Assembly (HI)		●		●
B133	Idler Assembly (HI)		●		●
B410	Pinch Arm Assembly		●		●
B414	M Brake (SP) Assembly (HI)		●		●
B416	M Brake (TU) Assembly (HI)		●		●
B525	LDG Belt		●		●

Notes:

1. Clean all parts for the tape transport (Upper Drum with Video Head / Pinch Roller / ACE Head / FE Head) using 90% ethyl alcohol.
2. After cleaning the parts, do all DECK ADJUSTMENTS.
3. For the reference numbers listed above, refer to Deck Exploded Views.

Cleaning

Cleaning of Video Head

Clean the head with a head cleaning stick or chamois cloth.

Procedure

1. Remove the top cabinet.
2. Put on a glove (thin type) to avoid touching the upper and lower drum with your bare hand.
3. Put a few drops of 90% ethyl alcohol on the head cleaning stick or on the chamois cloth and, by slightly pressing it against the head tip, turn the upper drum to the right and to the left.

Notes:

1. The video head surface is made of very hard material, but since it is very thin, avoid cleaning it vertically.
2. Wait for the cleaned part to dry thoroughly before operating the unit.
3. Do not reuse a stained head cleaning stick or a stained chamois cloth.

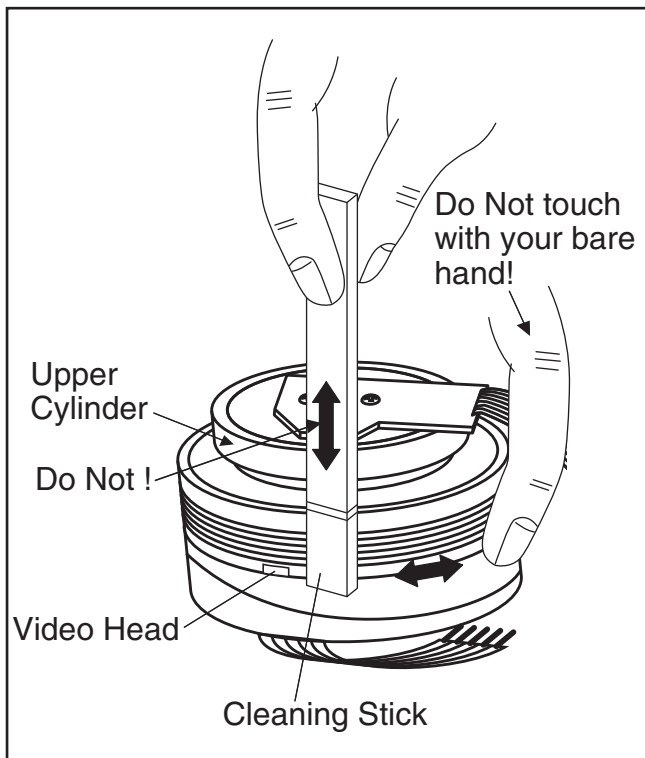

Cleaning of ACE Head

Clean the head with a cotton swab.

Procedure

1. Remove the top cabinet.
2. Dip the cotton swab in 90% ethyl alcohol and clean the ACE Head. Be careful not to damage the upper drum and other tape running parts.

Notes:

1. Avoid cleaning the ACE Head vertically.
2. Wait for the cleaned part to dry thoroughly before operating the unit or damage may occur.

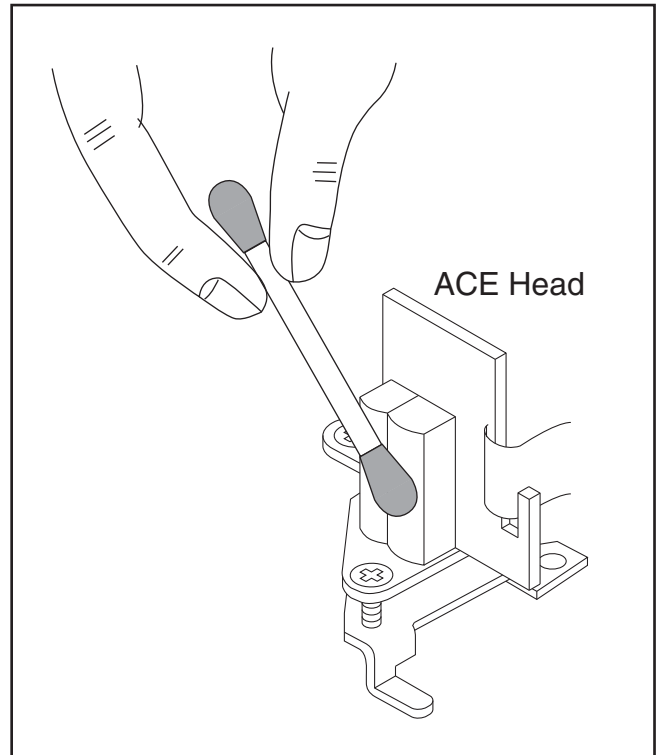

SERVICE FIXTURE AND TOOLS

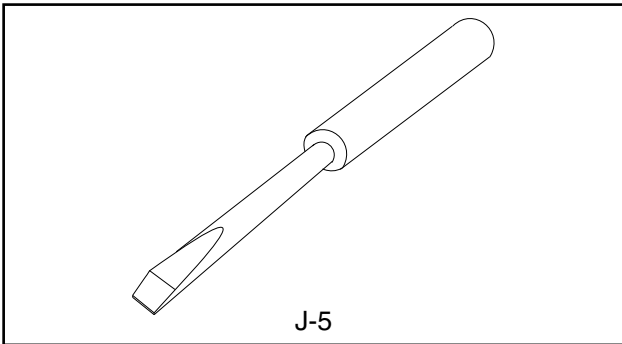
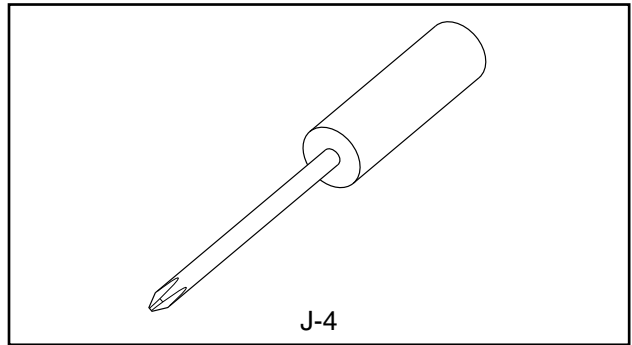
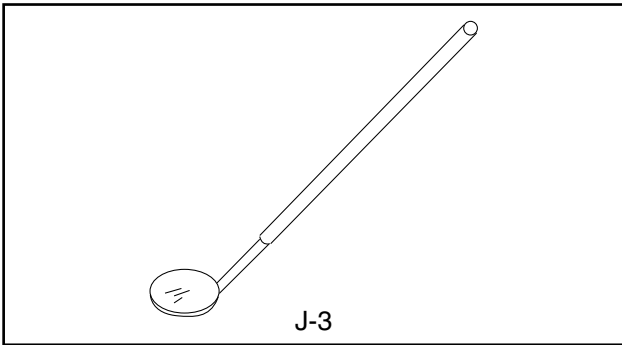
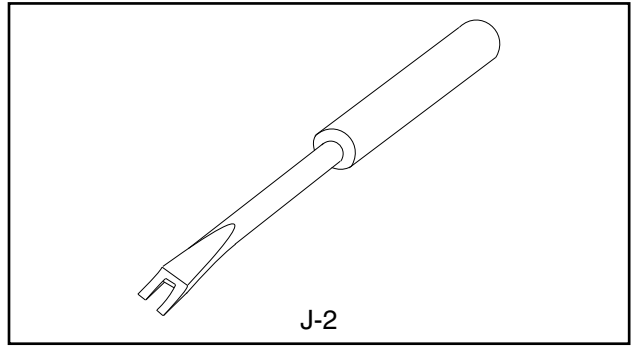
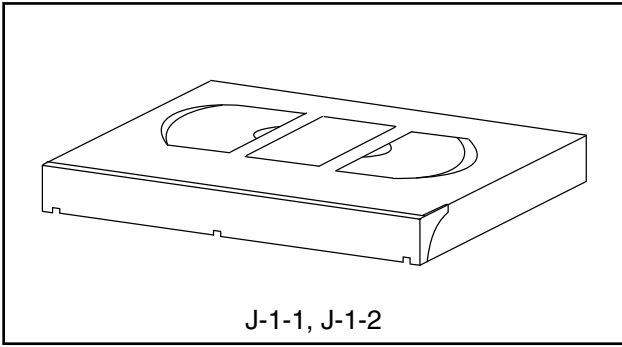

Ref. No.	Name	Part No.	Adjustment
J-1-1	Alignment Tape	FL6A	Head Adjustment of ACE Head
J-1-2	Alignment Tape	FL6N8 (2 Head model) FL6NS8 (4 Head model)	Azimuth and X Value Adjustment of ACE Head / Adjustment of Envelope Waveform
J-2	Guide Roller Adj. Screwdriver	Available Locally	Guide Roller
J-3	Mirror	Available Locally	Tape Transportation Check
J-4	Azimuth Adj. Screwdriver +	Available Locally	ACE Head Height
J-5	Flat Screwdriver -	Available Locally	X Value

MECHANICAL ALIGNMENT PROCEDURES

Explanation of alignment for the tape to correctly run starts on the next page. Refer to the information below on this page if a tape gets stuck, for example, in the mechanism due to some electrical trouble of the unit.

Service Information

A. Method for Manual Tape Loading/Unloading

To load a cassette tape manually:

1. Disconnect the AC plug.
2. Remove the Top Case and Front Assembly.
3. Insert a cassette tape. Though the tape will not be automatically loaded, make sure that the cassette tape is all the way in at the inlet of the Cassette Holder. To confirm this, lightly push the cassette tape further in and see if the tape comes back out, by a spring motion, just as much as you have pushed in.
4. Turn the LDG Belt in the appropriate direction shown in Fig. M1 for a minute or two to complete this task.

To unload a cassette tape manually:

1. Disconnect the AC plug.
2. Remove the Top Case and Front Assembly.
3. Make sure that the Moving guide preparations are in the Eject Position.
4. Turn the LDG Belt in the appropriate direction shown in Fig. M1 until the Moving guide preparations come to the Eject Position. Stop turning when the preparations begin clicking or can not be moved further. However, the tape will be left wound around the cylinder.
5. Turn the LDG Belt in the appropriate direction continuously, and the cassette tape will be ejected. Allow a minute or two to complete this task.

B. Method to place the Cassette Holder in the tape-loaded position without a cassette tape

1. Disconnect the AC Plug.
2. Remove the Top Case and Front Assembly.
3. Turn the LDG Belt in the appropriate direction shown in Fig. M1. Release the locking tabs shown in Fig. M1 and continue turning the LDG Belt until the Cassette Holder comes to the tape-loaded position. Allow a minute or two to complete this task.

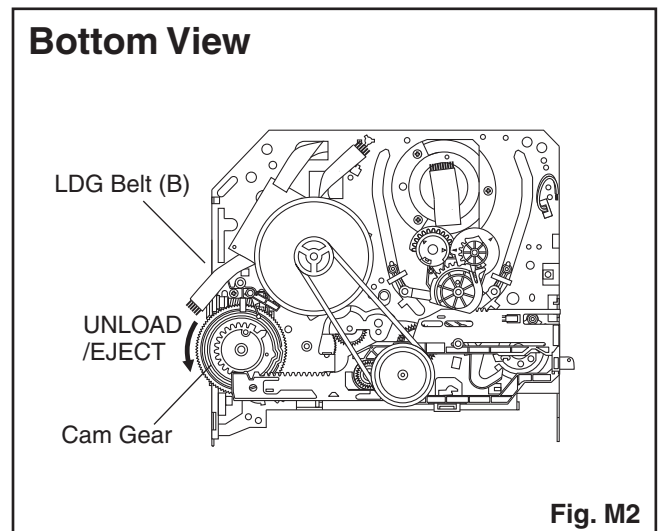
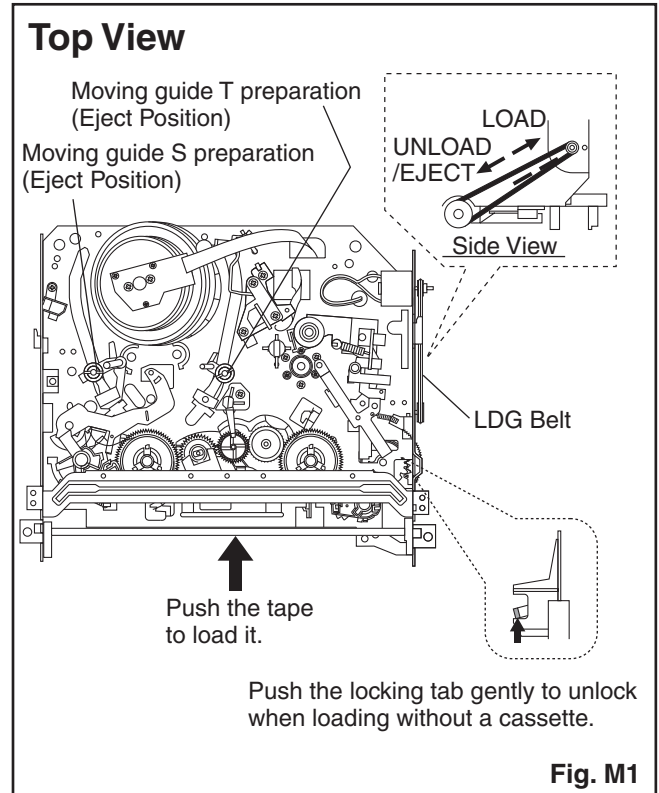

1. Tape Interchangeability Alignment

Note:

To do these alignment procedures, make sure that the Tracking Control Circuit is set to the preset position every time a tape is loaded or unloaded. (Refer to page 2-3-4, procedure 1-C, step 2.)

Equipment required:

- Dual Trace Oscilloscope
- VHS Alignment Tape (FL6NS8)
- Guide Roller Adj. Screwdriver
- Flat Screwdriver (Purchase Locally)

Note: Before starting this Mechanical Alignment, do all Electrical Adjustment procedures.

Flowchart of Alignment for tape traveling

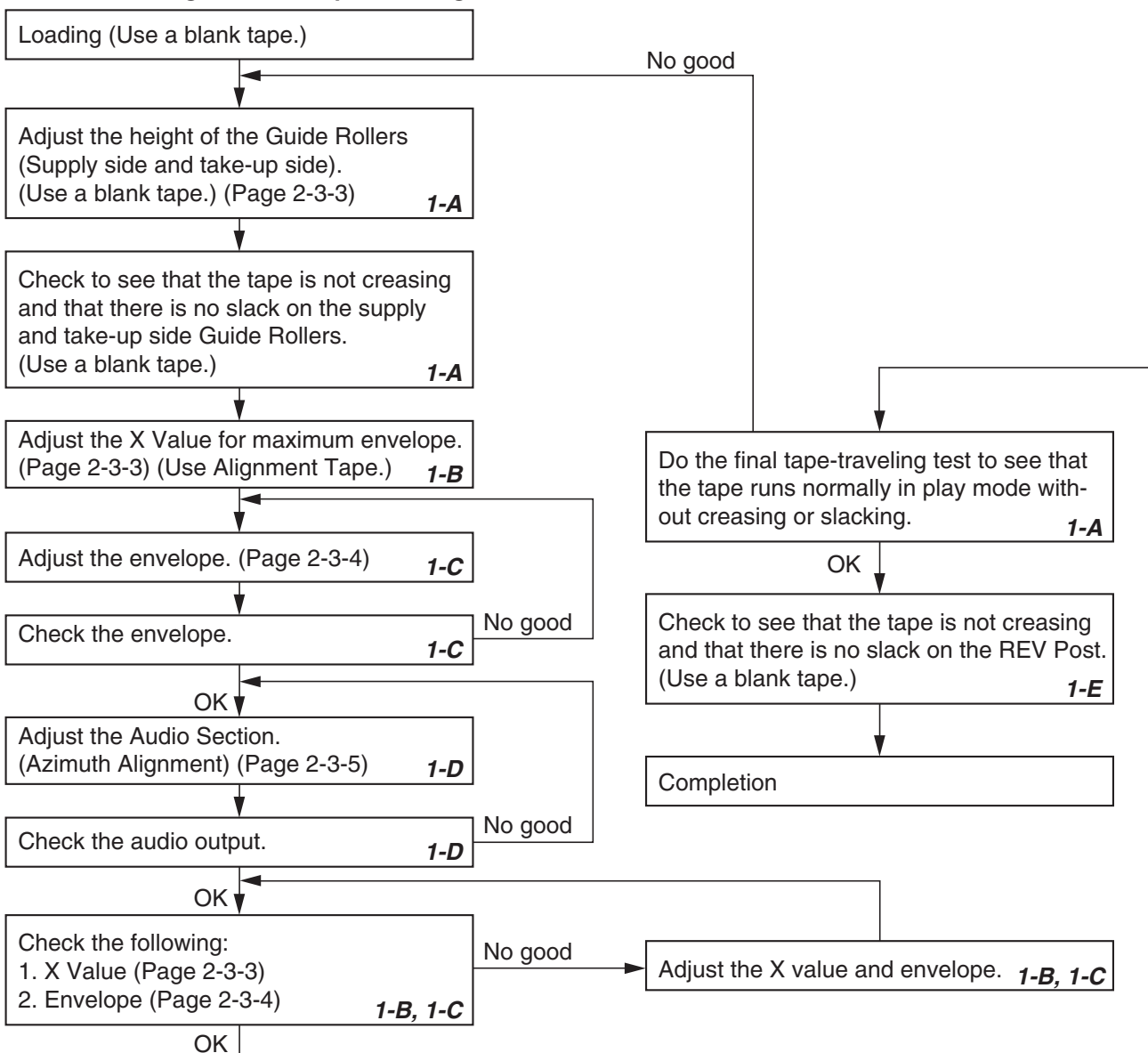

1-A. Preliminary/Final Checking and Alignment of Tape Path

Purpose:

To make sure that the tape path is well stabilized.

Symptom of Misalignment:

If the tape path is unstable, the tape will be damaged.

Note: Do not use an Alignment Tape for this procedure. If the unit is not correctly aligned, the tape may be damaged.

1. Playback a blank cassette tape and check to see that the tape runs without creasing at Guide Rollers [2] and [3], and at points A and B on the lead surface. (Refer to Fig. M3 and M4.)
2. If creasing is apparent, align the height of the guide rollers by turning the top of Guide Rollers [2] and [3] with a Guide Roller Adj. Screwdriver. (Refer to Fig. M3 and M5.)

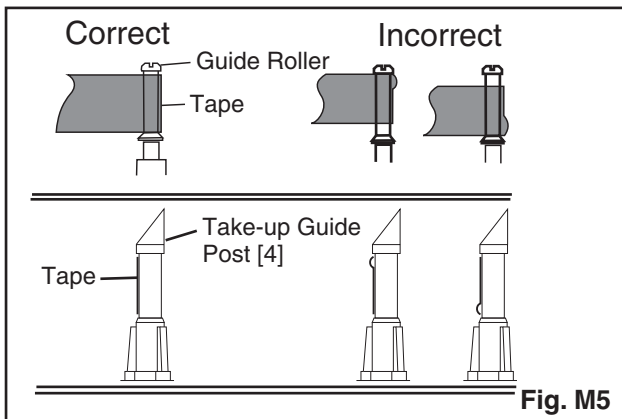
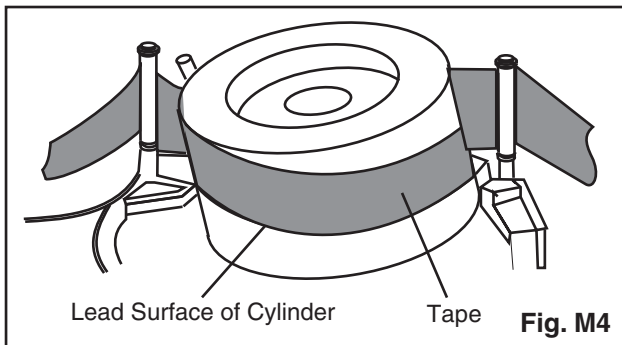
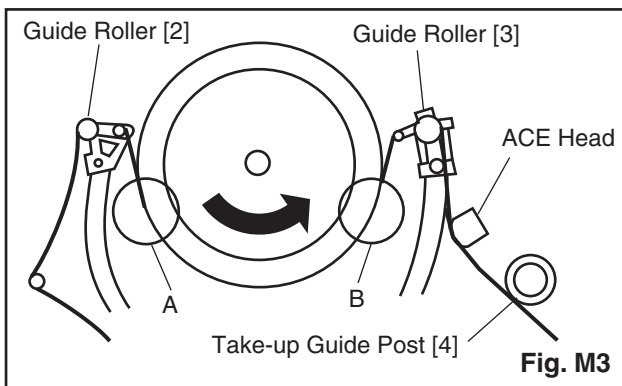

3. Check to see that the tape runs without creasing at Take-up Guide Post [4] or without snaking between Guide Roller [3] and ACE Head. (Fig. M3 and M5)

4. If creasing or snaking is apparent, adjust the Tilt Adj. Screw of the ACE Head. (Fig. M6)

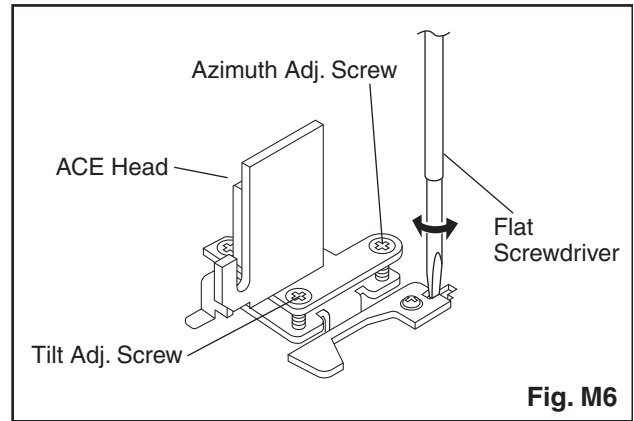

1-B. X Value Alignment

Purpose:

To obtain maximum PB FM envelope signal at the preset position of the Tracking Control Circuit, align the Horizontal Position of the ACE Head.

Symptom of Misalignment:

If the Horizontal Position of the ACE Head is not properly aligned, maximum PB FM envelope cannot be obtained at the preset position of the Tracking Control Circuit.

1. Connect the oscilloscope to TP301 (C-PB) and TP503 (CTL) on the BOARD AV. Use TP504 (RF-SW) as a trigger.
2. Playback the Gray Scale of the Alignment Tape (FL6NS8) and confirm that the PB FM signal is present.
3. Set the Tracking Control Circuit to the preset position by pressing [PROGRAM ^] button and then [▷] (VCR) button on the unit. (Refer to note on bottom of page 2-3-4.)
4. Use the Flat Screwdriver so that the PB FM signal at TP301 (C-PB) is maximum. (Fig. M6)

- To shift the CTL waveform, press [PROGRAM ^] or [PROGRAM v] button. Then make sure that the maximum output position of PB FM envelope signal becomes within $\pm 2\text{ms}$ from preset position.

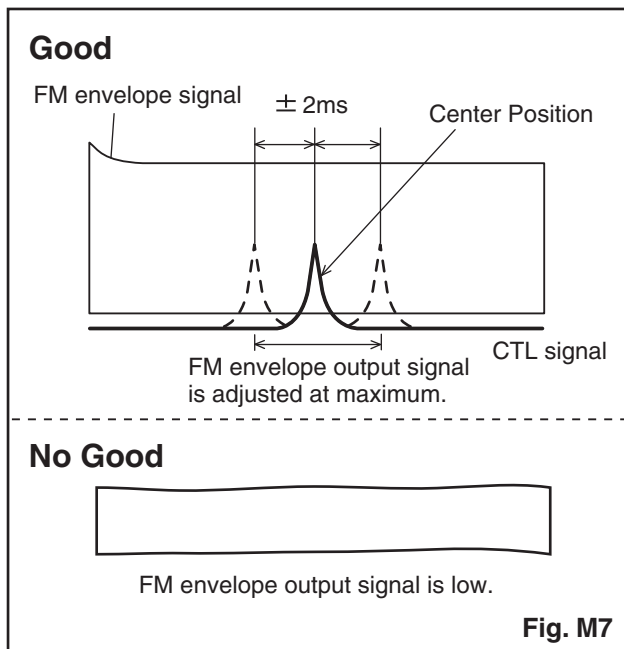

- Set the Tracking Control Circuit to the preset position by pressing [PROGRAM ^] button and then [▷] (VCR) button on the unit.

1-C. Checking/Adjustment of Envelope Waveform

Purpose:

To achieve a satisfactory picture, adjust the Guide Rollers so that the PB FM envelope becomes as flat as possible.

Symptom of Misalignment:

If the envelope output is poor, noise will appear in the picture. The tracking will then lose precision and the playback picture will be distorted by any slight variation of the Tracking Control Circuit.

- Connect the oscilloscope to TP301 (C-PB) on the BOARD AV. Use TP504 (RF-SW) as a trigger.
- Playback the Gray Scale on the Alignment Tape (FL6NS8). Set the Tracking Control Circuit to the preset position by pressing [PROGRAM ^] button and then [▷] (VCR) button on the unit. Adjust the height of Guide Rollers [2] and [3] (Fig. M3, Page 2-3-3) watching the oscilloscope display so that the envelope becomes as flat as possible. To do this adjustment, turn the top of the Guide Roller with the Guide Roller Adj. Screwdriver.
- If the envelope is as shown in Fig. M8, adjust the height of Guide Roller [2] (Refer to Fig. M3) so that the waveform looks like the one shown in Fig. M10.
- If the envelope is as shown in Fig. M9, adjust the height of Guide Roller [3] (Refer to Fig. M3) so that the waveform looks like the one shown in Fig. M10.
- When Guide Rollers [2] and [3] (Refer to Fig. M3) are aligned properly, there is no envelope drop

either at the beginning or end of track as shown in Fig. M10.

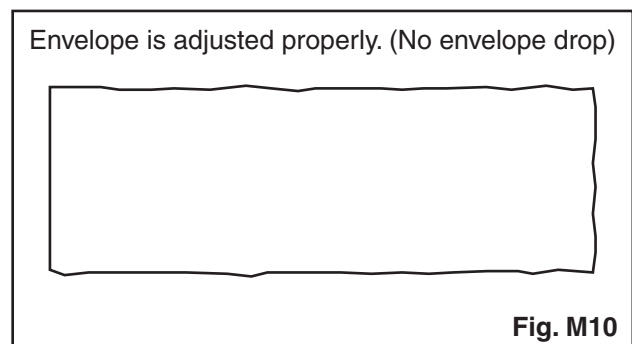
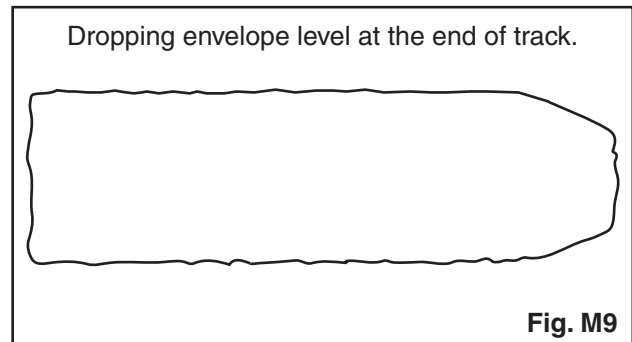
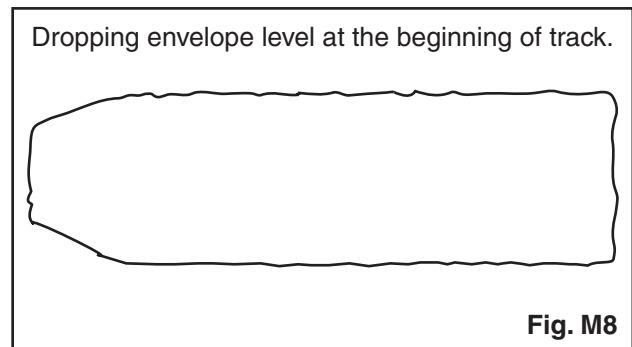

Note: Upon completion of the adjustment of Guide Rollers [2] and [3] (Refer to Fig. M3), check the X Value by pushing the [PROGRAM ^] or [PROGRAM v] buttons on the unit alternately, to check the symmetry of the envelope. Check the number of pushes to ensure preset position. The number of pushes of the [PROGRAM ^] button on the unit to achieve 1/2 level of envelope should match the number of pushes of the [PROGRAM v] button on the unit from center. If required, redo the "X Value Alignment."

1-D. Azimuth Alignment of Audio/Control/ Erase Head

Purpose:

To correct the Azimuth alignment so that the Audio/Control/Erase Head meets tape tracks properly.

Symptom of Misalignment:

If the position of the Audio/Control/Erase Head is not properly aligned, the Audio S/N Ratio or Frequency Response will be poor.

1. Connect the oscilloscope to the audio output jack on the rear side of the deck.
2. Playback the alignment tape (FL6NS8) and confirm that the audio signal output level is 8kHz.
3. Adjust Azimuth Adj. Screw so that the output level on the AC Voltmeter or the waveform on the oscilloscope is at maximum. (Fig. M6)

Note: Upon completion of the adjustment of Azimuth Adj. Screw, check the X Value by pushing the [PROGRAM ^] or [PROGRAM v] buttons on the unit alternately, to check the symmetry of the envelope. Check the number of pushes to ensure preset position. The number of pushes of the [PROGRAM ^] button on the unit to achieve 1/2 level of envelope should match the number of pushes of the [PROGRAM v] button on the unit from center. If required, redo the "X Value Alignment."

1-E. Checking and Alignment of Tape Path during reversing

Purpose:

To make sure that the tape path is well stabilized during reversing.

Symptom of Misalignment:

If the tape path is unstable during reversing, the tape will be damaged.

Note: Do not use an Alignment Tape for this procedure. If the unit is not correctly aligned, the tape may be damaged.

1. Insert a blank cassette tape into the tray and set the unit to REV. Then confirm if the tape has been curled up or bent at the Take-up Guide Post[4] or REV Post[5]. (Refer to Fig. M11 and M12.)

2. When the tape has been curled up or bent, turn the alignment screw to adjust the height of REV Post. (Refer to Fig. M11 and M13.)

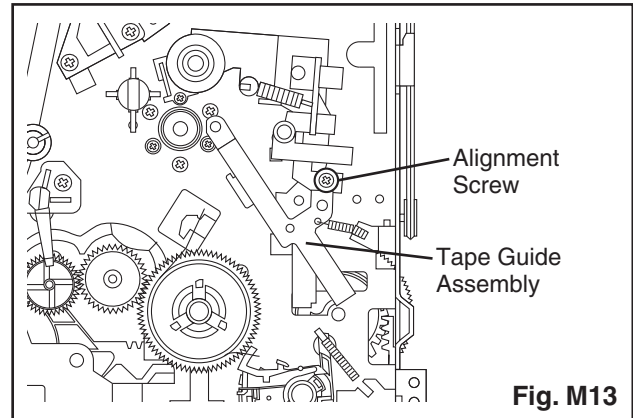
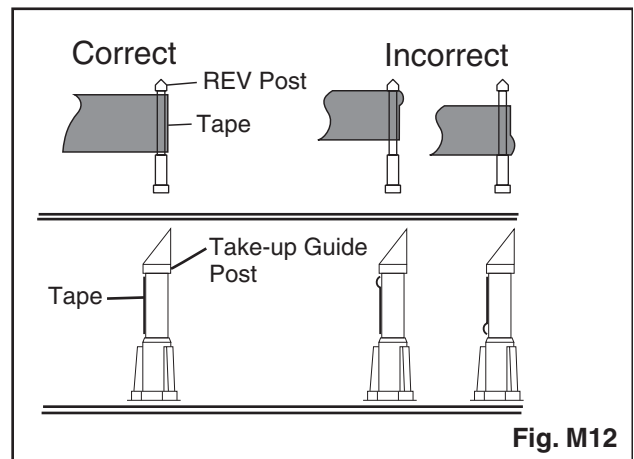
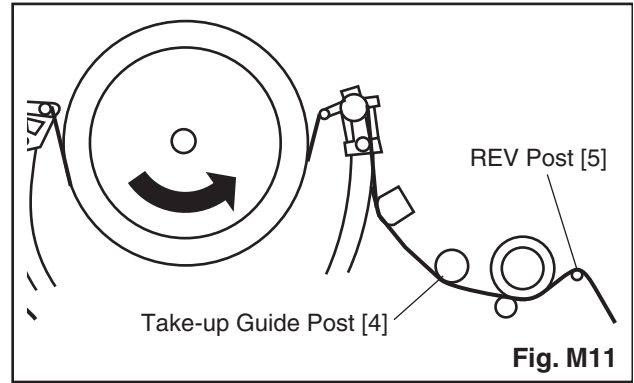

DISASSEMBLY/ASSEMBLY PROCEDURES OF DECK MECHANISM

Before following the procedures described below, be sure to remove the deck assembly from the cabinet. (Refer to CABINET DISASSEMBLY INSTRUCTIONS.)

All the following procedures, including those for adjustment and replacement of parts, should be done in Eject mode; see the positions of [44] and [45] in Fig. DM1H on page 2-4-3. When reassembling, follow the steps in reverse order.

STEP /LOC. No.	START-ING No.	PART		REMOVAL		INSTALLATION
				Fig. No.	REMOVE/*UNHOOK/ UNLOCK/RELEASE/ UNPLUG/DESOLDER	ADJUSTMENT CONDITION
[1]	[1]	Guide Holder A	T	DM3H	2(S-1)	
[2]	[1]	Cassette Holder Assembly	T	DM4H		
[3]	[2]	Slider (SP)	T	DM5H	(S-1A), *(L-1)	
[4]	[2]	Slider (TU)	T	DM5H	*(L-2)	
[5]	[4]	Lock Lever	T	DM5H	*(L-3), *(P-1)	
[6]	[2]	Cassette Plate	T	DM5H		
[7]	[7]	Cylinder Assembly	T	DM1H, DM6H	Desolder, 3(S-2)	
[8]	[8]	Loading Motor Assembly	T	DM1H, DM7H	Desolder, LDG Belt, 2(S-3)	
[9]	[9]	ACE Head Assembly	T	DM1H, DM7H	(S-4)	
[10]	[2]	Tape Guide Arm Assembly	T	DM1H, DM8H-1	*(P-2)	
[11]	[10]	C Door Opener	T	DM1H, DM8H-1	(S-4A), *(L-4)	
[12]	[11]	Pinch Arm (B)	T	DM1H, DM8H-1, DM8H-2	*(P-3)	
[13]	[12]	Pinch Arm (A) Assembly	T	DM1H, DM8H-1, DM8H-2		
[14]	[14]	FE Head	T	DM1H, DM9H	(S-5)	
[15]	[15]	Prism	T	DM1H, DM9H	(S-6)	
[16]	[2]	Slider Shaft	T	DM10H	*(L-5)	
[17]	[16]	C Drive Lever (SP)	T	DM10H		
[18]	[16]	C Drive Lever (TU)	T	DM10H	(S-7), *(P-4)	
[19]	[19]	Capstan Motor	B	DM2H, DM11H	3(S-8), Cap Belt	
[20]	[20]	Clutch Assembly (HI)	B	DM2H, DM12H	(C-1)	
[21]	[20]	Center Gear	B	DM12H		
[22]	[22]	F Brake Assembly (HI)	B	DM2H, DM12H	*(L-6)	
[23]	[22]	Worm Holder	B	DM2H, DM13H-1	(S-9), *(L-7), *(L-8)	
[24]	[22]	Pulley Assembly (HI)	B	DM2H, DM13H-1		
[25]	[25]	Mode Gear (LM)	B	DM2H, DM13H-1	(C-2)	
[25a]	[1],[25a]	Holder ML SHARP HI-SPEED	B	DM2H, DM13H-1	(S-9a)	
[26]	[20],[25]	Mode Lever (HI)	B	DM2H, DM13H-1, DM13H-2	(C-3)	
[27]	[22],[23],[26]	Cam Gear (A) (HI)	B	DM2H, DM13H-1, DM13H-2	(C-4)	(+)Refer to Alignment Sec. Page 2-5-1
[28]	[26]	TR Gear C	B	DM2H, DM13H-1	(C-5)	
[29]	[28]	TR Gear Spring	B	DM13H-1		
[30]	[29]	TR Gear A/B	B	DM13H-1		
[31]	[31]	FF Arm (HI)	B	DM1H, DM14H		

STEP /LOC. No.	START-ING No.	PART		REMOVAL		INSTALLATION
				Fig. No.	REMOVE/*UNHOOK/ UNLOCK/RELEASE/ UNPLUG/DESOLDER	ADJUSTMENT CONDITION
[32]	[26]	Idler Assembly (HI)	B	DM1H, DM14H	*(L-9)	
[33]	[26]	BT Arm	B	DM2H, DM14H	*(P-5)	
[34]	[26]	Loading Arm (SP) Assembly	B	DM2H, DM14H		(+)Refer to Alignment Sec. Page 2-5-1
[35]	[34]	Loading Arm (TU) Assembly	B	DM2H, DM14H		(+)Refer to Alignment Sec. Page 2-5-1
[36]	[16],[26]	M Brake (TU) Assembly (HI)	T	DM1H, DM15H		
[37]	[2],[26]	M Brake (SP) Assembly (HI)	T	DM1H, DM15H	*(P-6)	
[38]	[37]	Tension Lever Assembly	T	DM1H, DM15H		
[39]	[38]	T Lever Holder	T	DM15H	*(L-10)	
[40]	[40]	M Gear (HI)	T	DM1H, DM15H	(C-6)	
[41]	[15],[40]	Sensor Gear (HI)	T	DM1H, DM15H	(C-7)	
[42]	[36],[40]	Reel T	T	DM1H, DM15H		
[43]	[38]	Reel S	T	DM1H, DM15H		
[44]	[34],[38]	Moving Guide S Preparation	T	DM1H, DM16H	(S-11), Slide Plate	
[45]	[35]	Moving Guide T Preparation	T	DM1H, DM16H		
[46]	[19]	TG Post Assembly	T	DM1H, DM16H	*(L-11)	
[47]	[27]	Rack Assembly	R	DM17H		(+)Refer to Alignment Sec. Page 2-5-1
[48]	[47]	F Door Opener	R	DM17H		
[49]	[49]	Cleaner Assembly	T	DM1H, DM6H		
[50]	[49]	CL Post	T	DM6H	*(L-12)	
↓ (1)	↓ (2)	↓ (3)	↓ (4)	↓ (5)	↓ (6)	↓ (7)

(1): Follow steps in sequence. When reassembling, follow the steps in reverse order.

These numbers are also used as identification (location) No. of parts in the figures.

(2): Indicates the part to start disassembling with in order to disassemble the part in column (1).

(3): Name of the part

(4): Location of the part: T=Top B=Bottom R=Right L=Left

(5): Figure Number

(6): Identification of parts to be removed, unhooked, unlocked, released, unplugged, unclamped, or desoldered.

P=Spring, W=Washer, C=Cut Washer, S=Screw, *=Unhook, Unlock, Release, Unplug, or Desolder

e.g., 2(L-2) = two Locking Tabs (L-2).

(7): Adjustment Information for Installation

(+):Refer to Deck Exploded Views for lubrication.

Top View

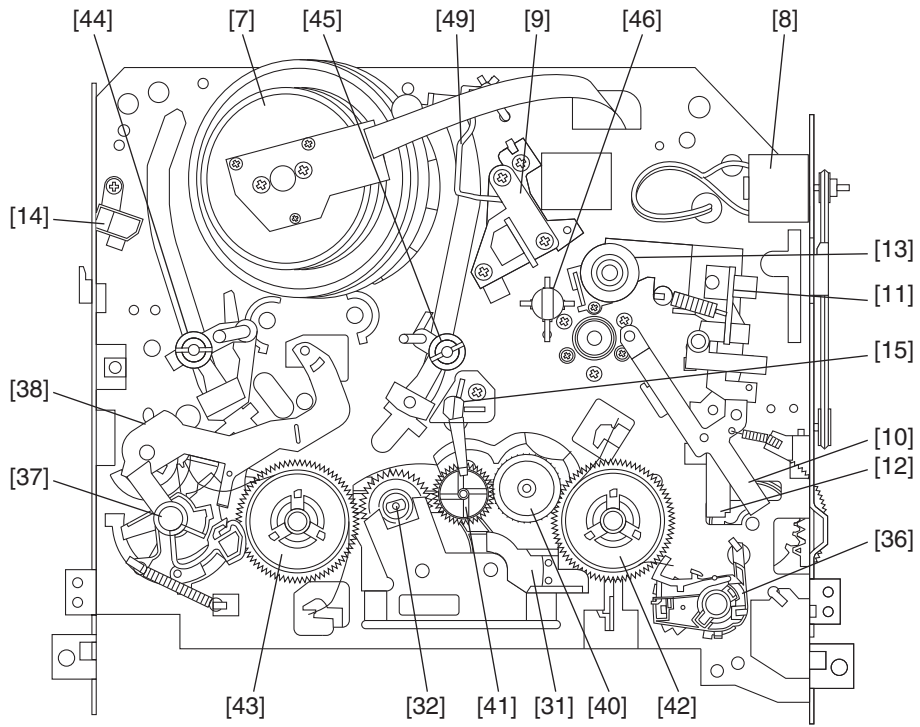

Fig. DM1H

Bottom View

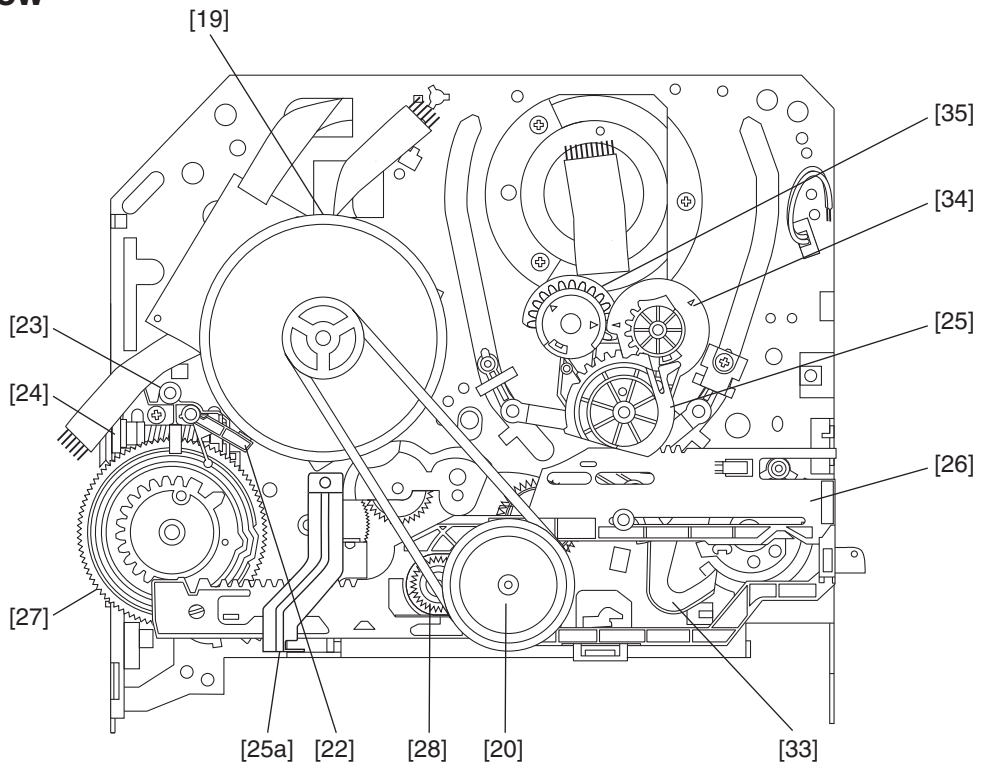

Fig. DM2H

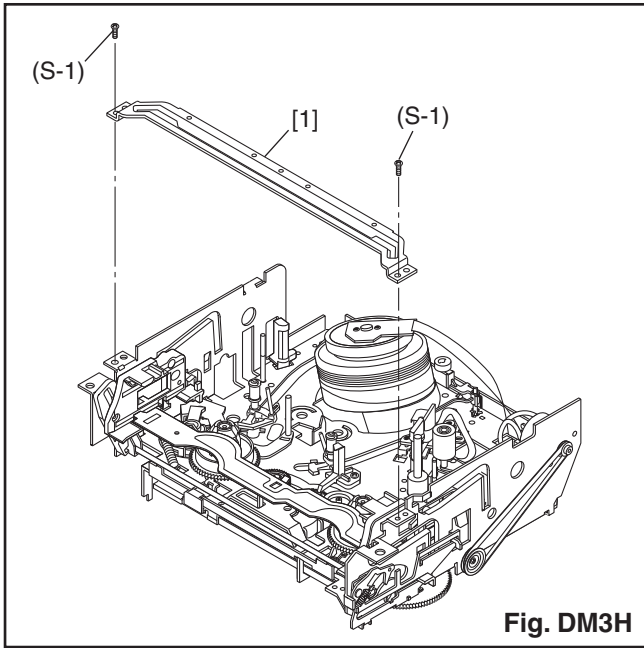
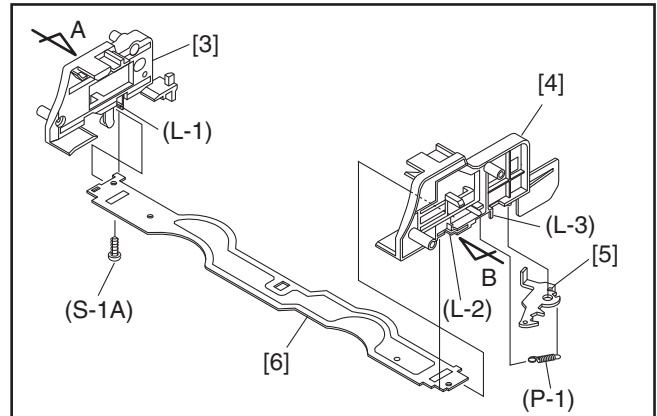
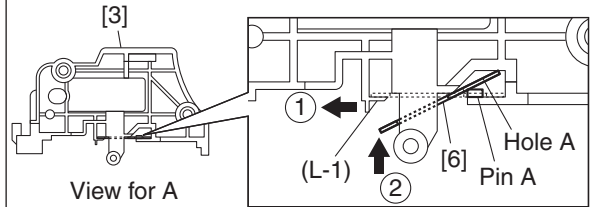

Fig. DM3H



Installation of [3] and [6]

First, insert [6] diagonally in [3] as shown below. Then, install [6] in [3] while pushing (L-1) in the direction of the arrow. After installing [6] in [3], confirm that pin A of [3] enters hole A of [6] properly.



Installation of [4] and [6]

Install [6] in [4] while pulling (L-2) in the direction of the arrow. After installing [6] in [4], confirm that pin B of [4] enters hole B of [6] properly.

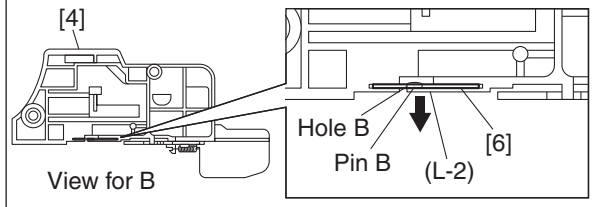
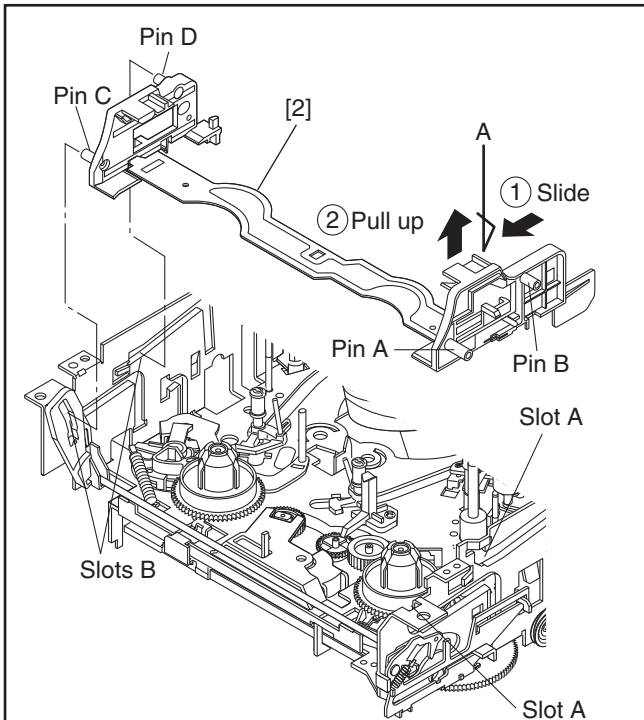

Fig. DM5H



First, while pushing the locking tab as shown in the right, slide and pull up the right side on [2] to release Pin A and Pin B from the slots A. Then, remove Pin C and Pin D on [2] from the slots B as shown.

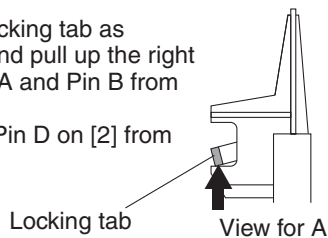

Fig. DM4H

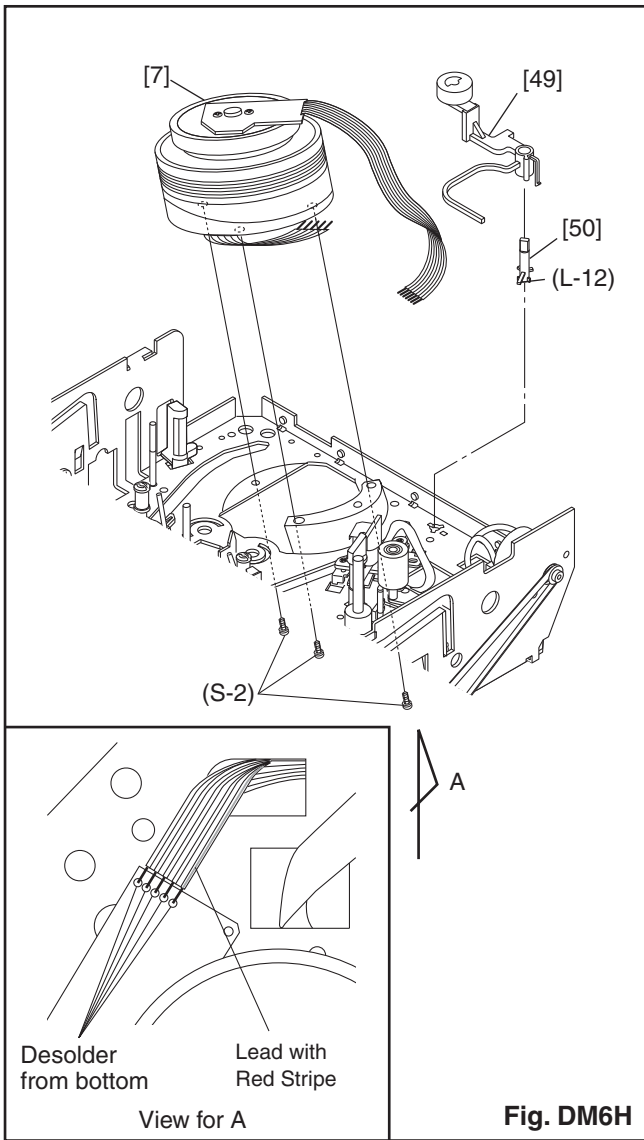

Fig. DM6H

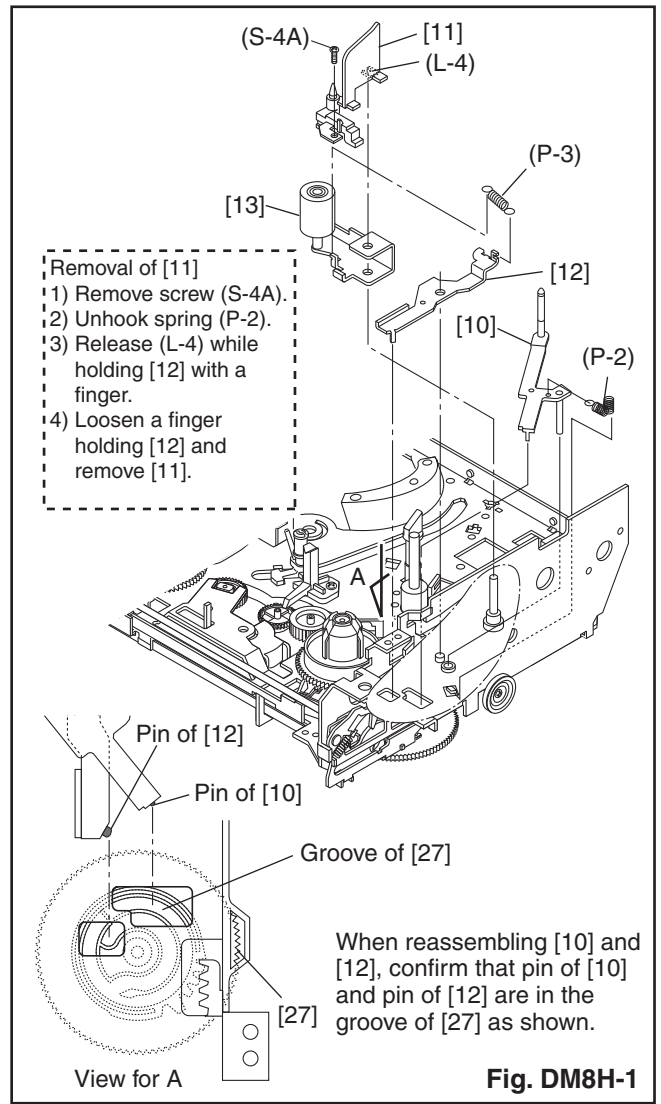

Fig. DM8H-1

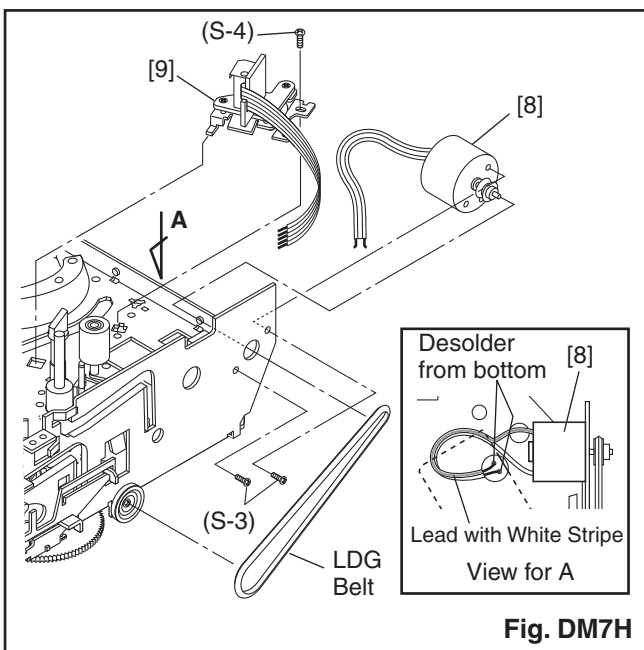

Fig. DM7H

Installation of [13] and [12]

Hook spring (P-3) up to [12] and [13], then install them to the specified position so that [12] will be floated slightly while holding [12] and [13]. (Refer to Fig. A.)

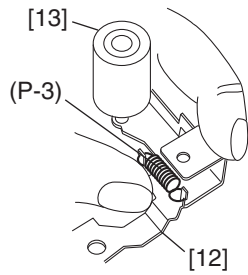

Fig. A

Install pin of [12] in groove of [27]. (Refer to Fig. B.)

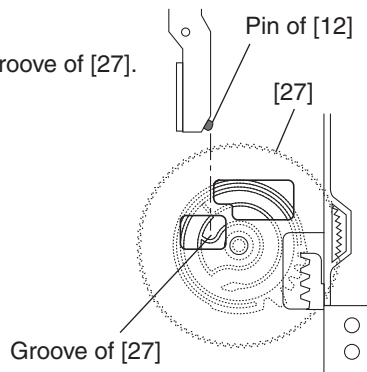

Fig. B (Top view)

Press both [12] and [13] till the groove of chassis pin appears, and adjust [13] to the notch of chassis. Then turn [13] a little in the direction of the arrow while pressing [12]. (Refer to Fig. C.)

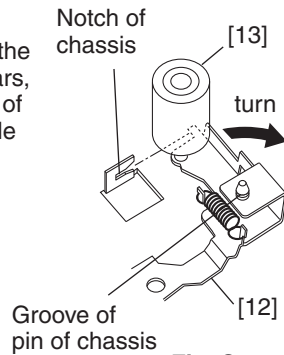

Fig. C

Install [11] and [10] while holding [12]. (Refer to Fig. DM8H-1.)

Fig. DM8H-2

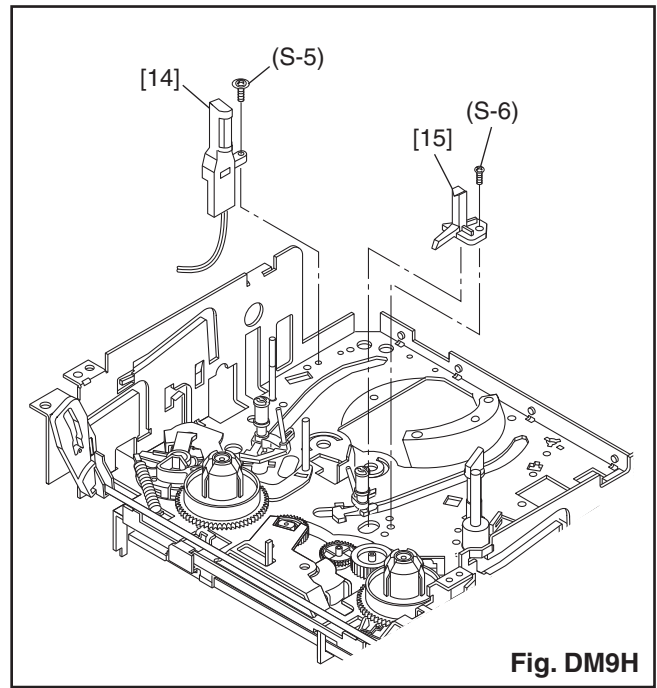

Fig. DM9H

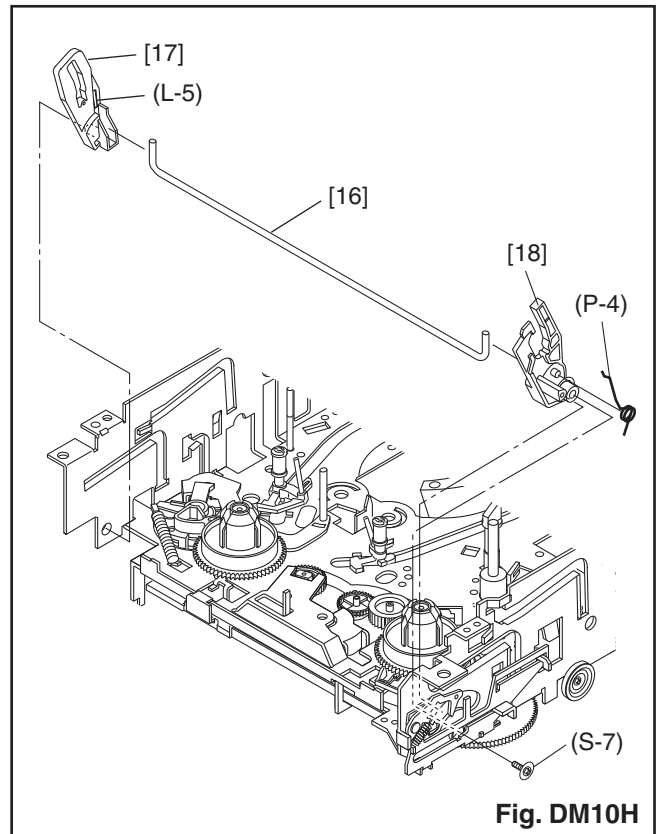
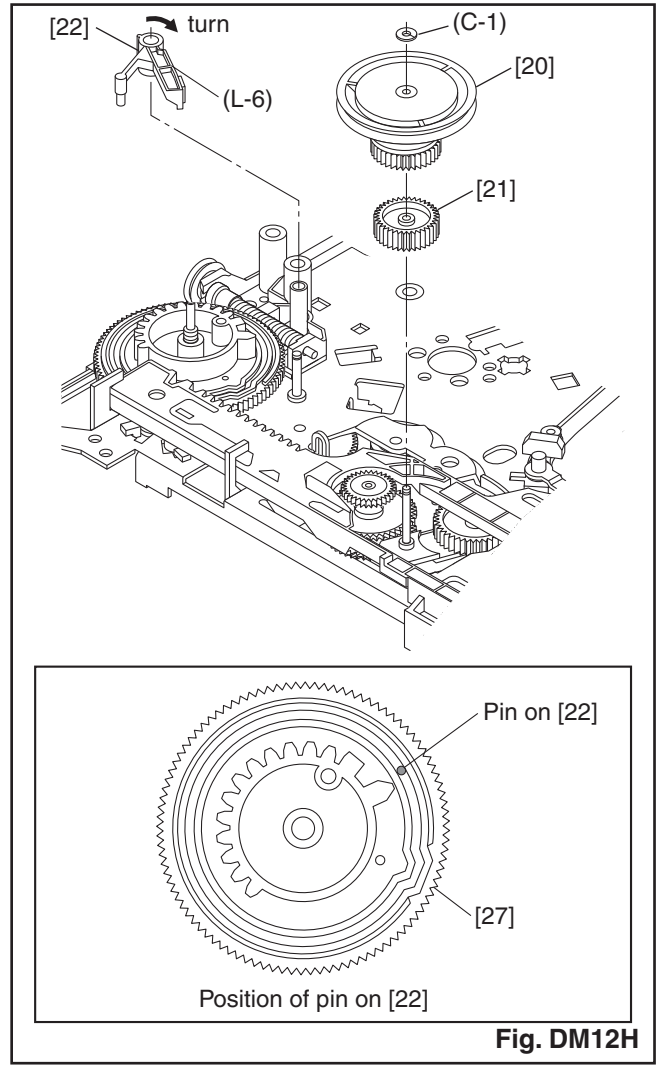
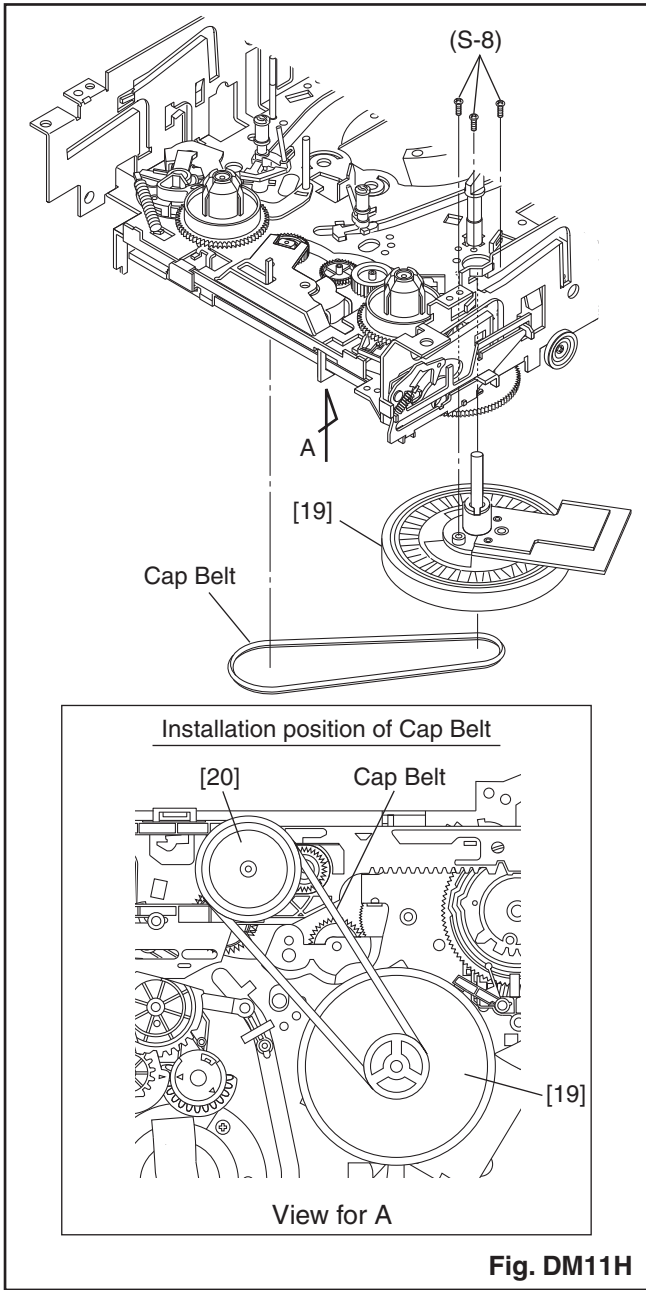

Fig. DM10H



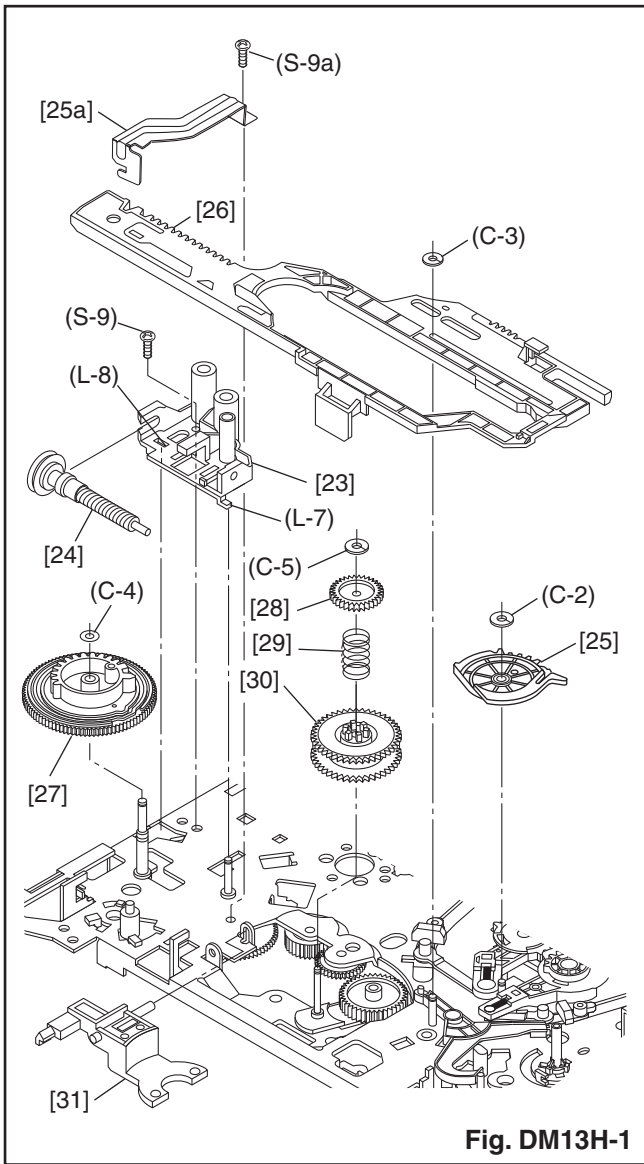
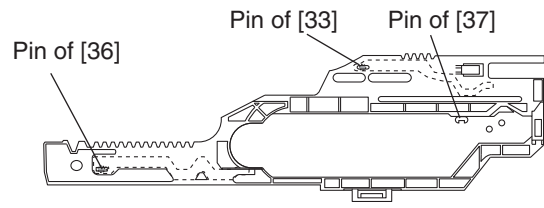

Fig. DM13H-1

Installation of [26]

Position of Mode Lever when installed



Bottom View

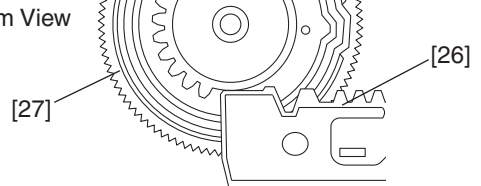

Align [26] and [27] as shown.

Top View

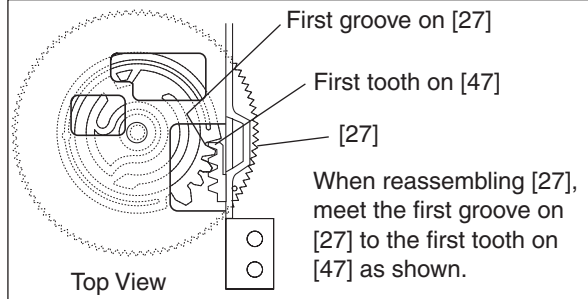

Fig. DM13H-2

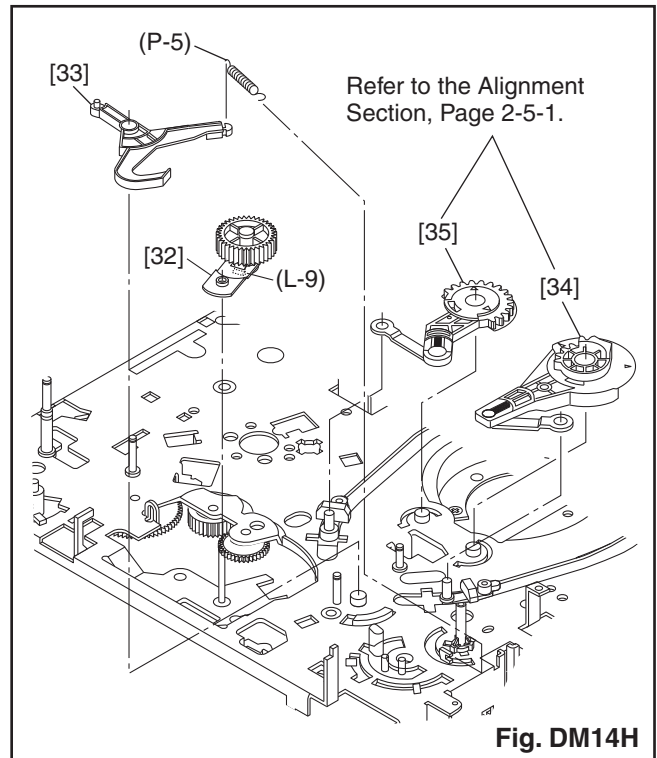
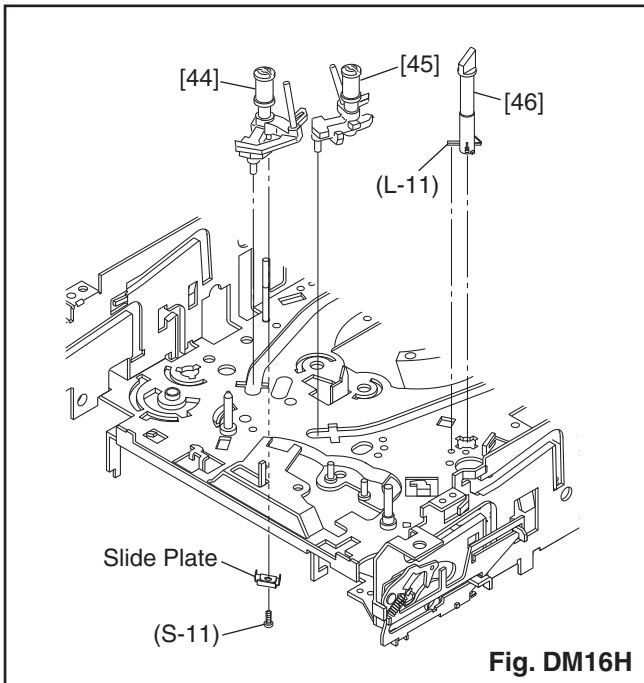
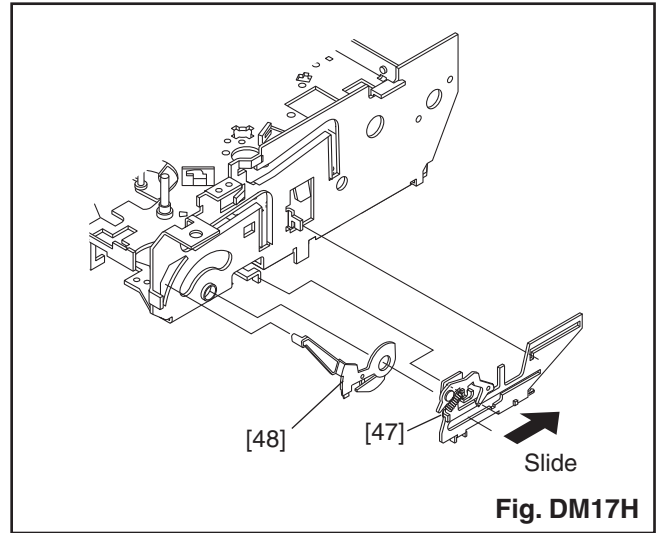
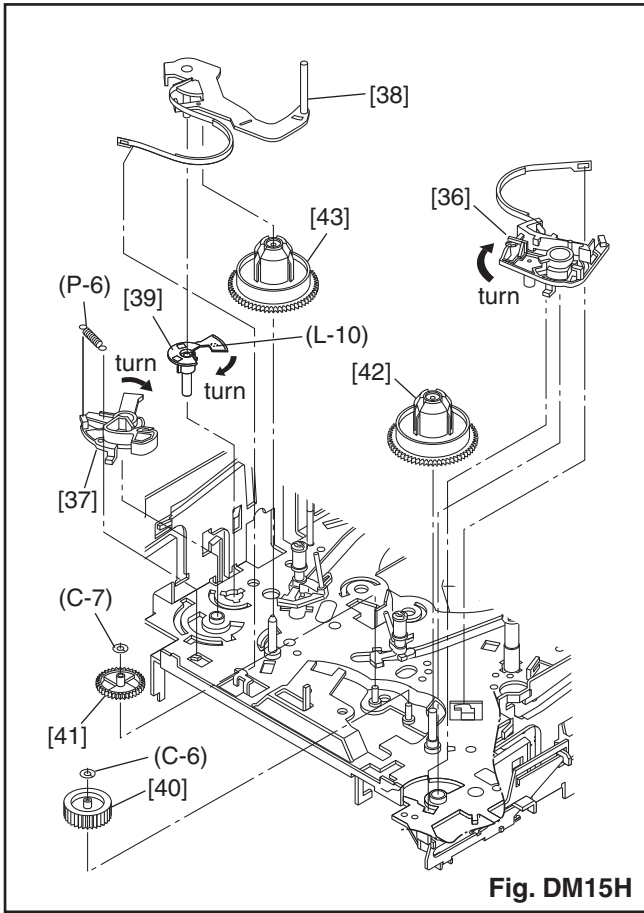

Fig. DM14H



ALIGNMENT PROCEDURES OF MECHANISM

The following procedures describe how to align the individual gears and levers that make up the tape loading/unloading mechanism. Since information about the state of the mechanism is provided to the System Control Circuit only through the Mode Switch, it is essential that the correct relationship between individual gears and levers be maintained.

All alignments are to be performed with the mechanism in Eject mode, in the sequence given. Each procedure assumes that all previous procedures have been completed.

IMPORTANT:

If any one of these alignments is not performed properly, even if off by only one tooth, the unit will unload or stop and it may result in damage to the mechanical or electrical parts.

Alignment points in Eject Position

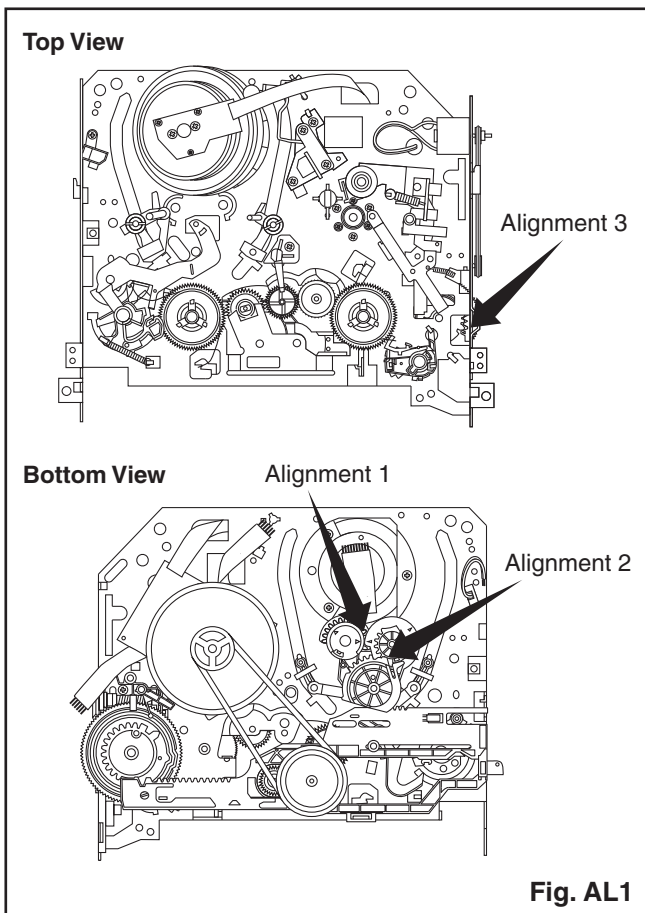

Alignment 1

Loading Arm (SP) and (TU) Assembly

Install Loading Arm (SP) and (TU) Assembly so that their triangle marks point to each other as shown in Fig. AL2.

Alignment 2

Mode Gear

Keeping the two triangles pointing at each other, install the Loading Arm (SP) Assembly so that the last tooth of the gear meets the most inside teeth of the Mode Gear. See Fig. AL2.

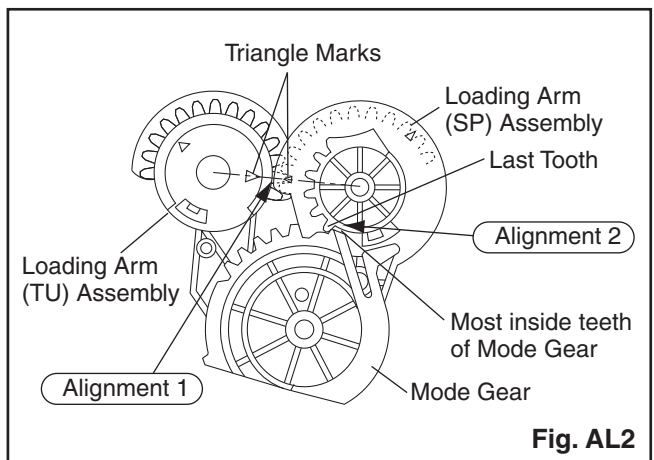

Alignment 3

Cam Gear (A) (HI), Rack Assembly

Install the Rack Assembly so that the first tooth on the gear of the Rack Assembly meets the first groove on the Cam Gear (A) (HI) as shown in Fig. AL3.

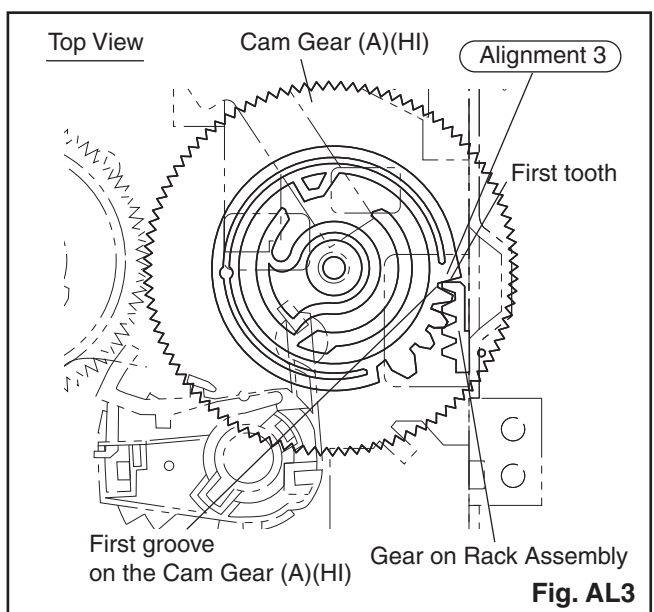

DECK EXPLODED VIEWS

Deck Mechanism View 1

Mark	Description
•••••	Foil G-684G or Multemp MH-D (Blue grease)
▲▲▲▲▲	SLIDUS OIL #150

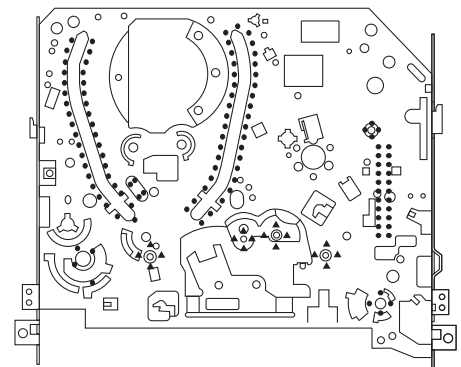
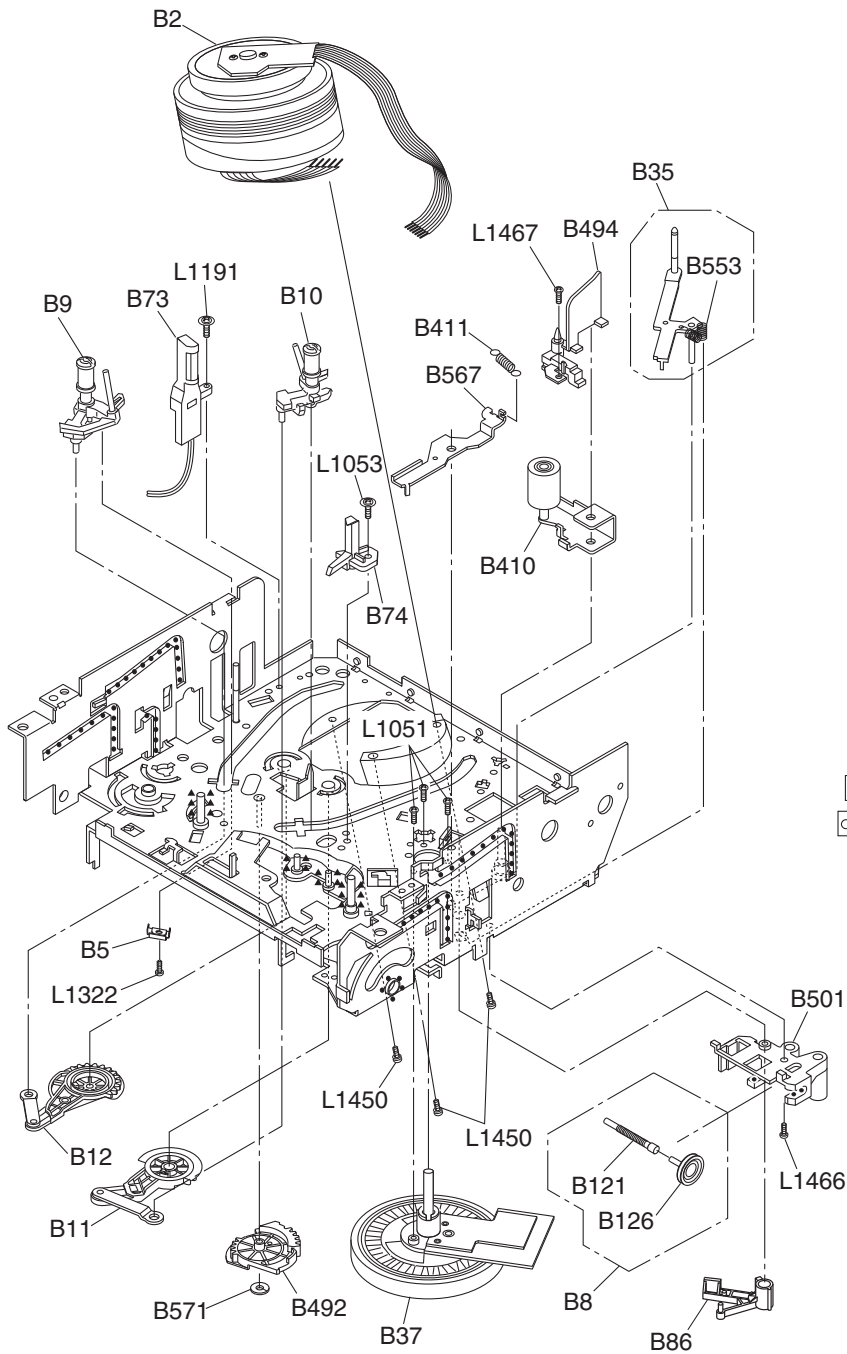

Chassis Assembly
Top View (Lubricating Point)

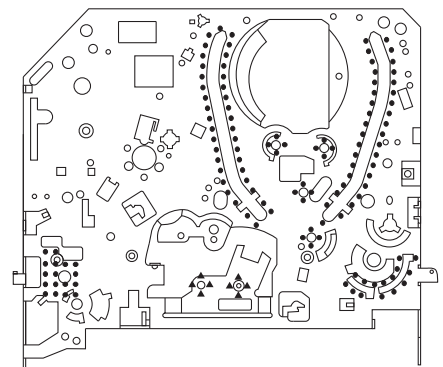

Chassis Assembly
Bottom View (Lubricating Point)

Some Ref. Numbers are not in sequence.

Deck Mechanism View 2

Mark	Description
•••••	Floil G-684G or Multemp MH-D (Blue grease)
▲▲▲▲▲	SLIDUS OIL #150
×××××	SANKOUL FG84M (Yellow grease)

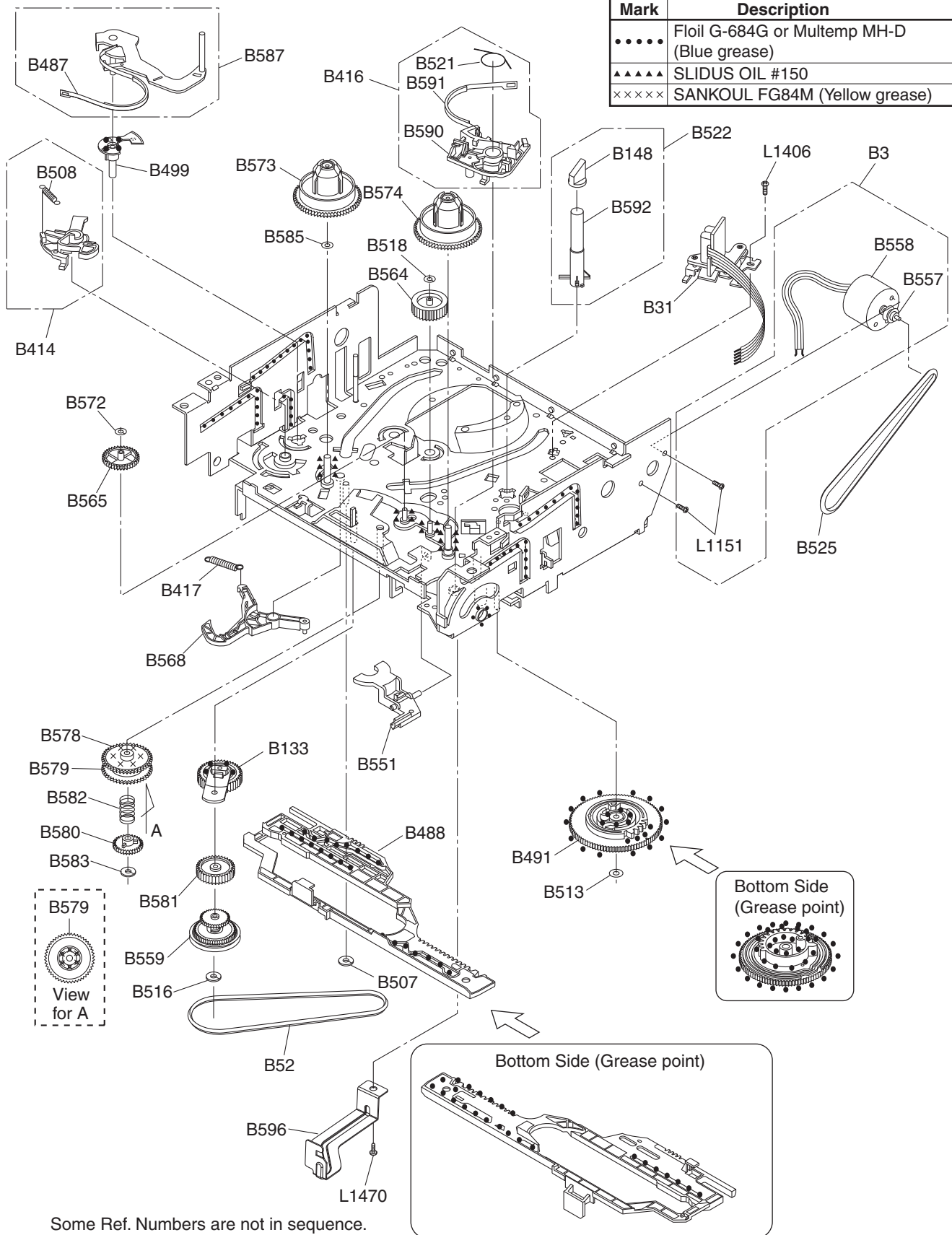

Some Ref. Numbers are not in sequence.

Deck Mechanism View 3

Mark	Description
•••••	Floil G-684G or Multemp MH-D (Blue grease)
▲▲▲▲▲	SLIDUS OIL #150

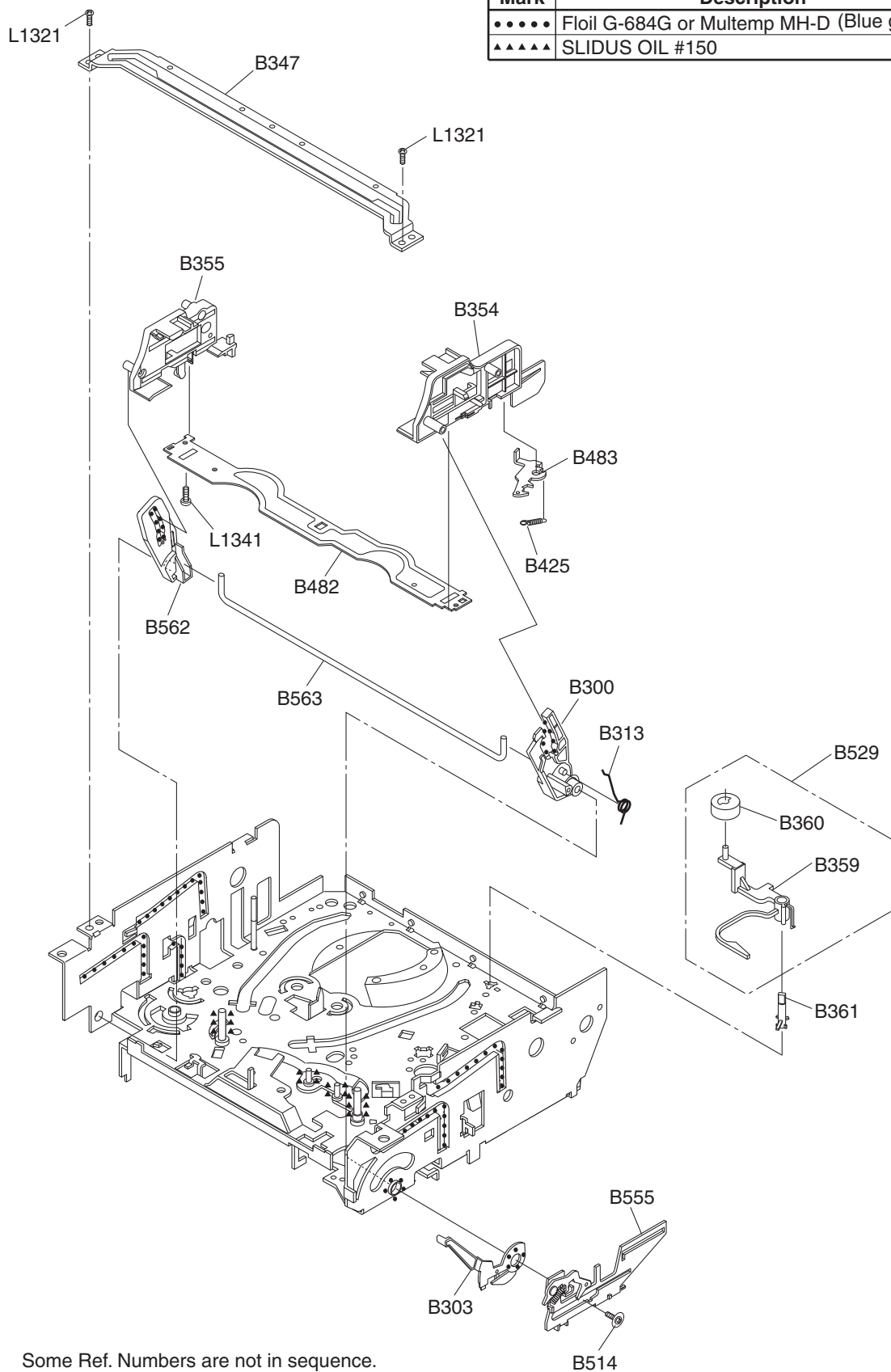

Some Ref. Numbers are not in sequence.

TOSHIBA CORPORATION

1-1, SHIBAURA 1-CHOME, MINATO-KU, TOKYO 105-8001, JAPAN