

STEREO RECEIVER

RX-V480/R-V98

SERVICE MANUAL

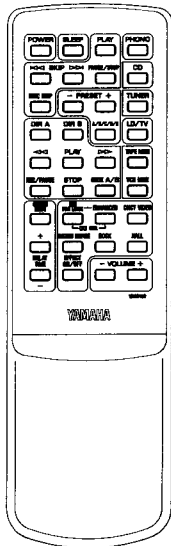
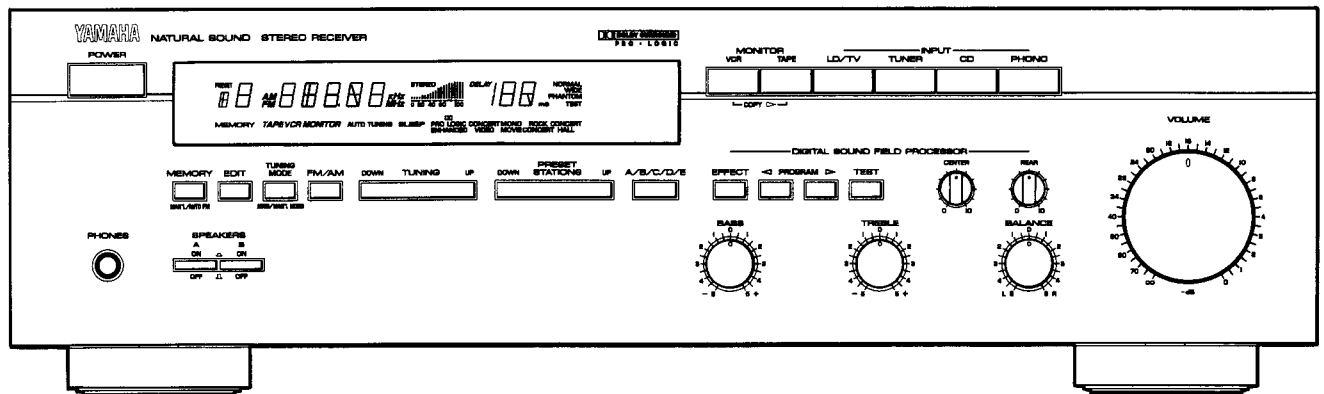

IMPORTANT NOTICE

This manual has been provided for the use of authorized YAMAHA Retailers and their service personnel. It has been assumed that basic service procedures inherent to the industry, and more specifically YAMAHA Products, are already known and understood by the users, and have therefore not been restated.

WARNING: Failure to follow appropriate service and safety procedures when servicing this product may result in personal injury, destruction of expensive components, and failure of the product to perform as specified. For these reasons, we advise all YAMAHA product owners that any service required should be performed by an authorized YAMAHA Retailer or the appointed service representative.

IMPORTANT: The presentation or sale of this manual to any individual or firm does not constitute authorization, certification or recognition of any applicable technical capabilities, or establish a principle-agent relationship of any form.

The data provided is believed to be accurate and applicable to the unit(s) indicated on the cover. The research, engineering, and service departments of YAMAHA are continually striving to improve YAMAHA products. Modifications are, therefore, inevitable and specifications are subject to change without notice or obligation to retrofit. Should any discrepancy appear to exist, please contact the distributor's Service Division.

WARNING: Static discharges can destroy expensive components. Discharge any static electricity your body may have accumulated by grounding yourself to the ground buss in the unit (heavy gauge black wires connect to this buss).

IMPORTANT: Turn the unit OFF during disassembly and part replacement. Recheck all work before you apply power to the unit.

CONTENTS

TO SERVICE PERSONNEL	1	BLOCK DIAGRAM	17~19
REAR PANELS	1~2	PRINTED CIRCUIT BOARD	20~29
SPECIFICATIONS	3~4	DISPLAY DATA	30
INTERNAL VIEW	5	TEST POINT WAVEFORMS	31
DISASSEMBLY PROCEDURES	5	SCHEMATIC DIAGRAM	32~36
TEST SIGNAL PROGRAM	6~7	PARTS LIST	37~47
ADJUSTMENTS	8~12	REMOTE CONTROL TRANSMITTER	48
IC DATA	13~16		

■ TO SERVICE PERSONNEL

1. Critical Components Information.
Components having special characteristics are marked and must be replaced with parts having specifications equal to those originally installed.
2. Leakage Current Measurement (For 120V Models Only).
When service has been completed, it is imperative to verify that all exposed conductive surfaces are properly insulated from supply circuits.
 - Meter impedance should be equivalent to 1500 ohm shunted by 0.15μF.
 - Leakage current must not exceed 0.5mA.
 - Be sure to test for leakage with the AC plug in both polarities.

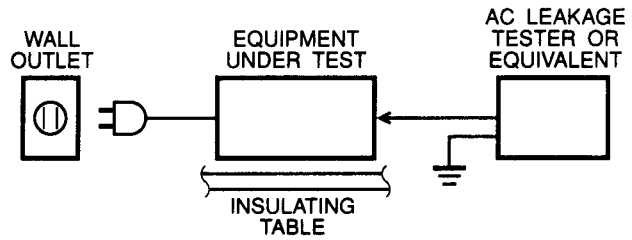

WARNING: CHEMICAL CONTENT NOTICE!

The solder used in the production of this product contains LEAD. In addition, other electrical/electronic and/or plastic (where applicable) components may also contain traces of chemicals found by the California Health and Welfare Agency (and possibly other entities) to cause cancer and/or birth defects or other reproductive harm.

DO NOT PLACE SOLDER, ELECTRICAL/ELECTRONIC OR PLASTIC COMPONENTS IN YOUR MOUTH FOR ANY REASON WHATSOEVER!

Avoid prolonged, unprotected contact between solder and your skin! When soldering, do not inhale solder fumes or expose eyes to solder/flux vapor!

If you come in contact with solder or components located inside the enclosure of this product, wash your hands before handling food.

■ REAR PANELS

▼ RX-V480/R-V98 U model

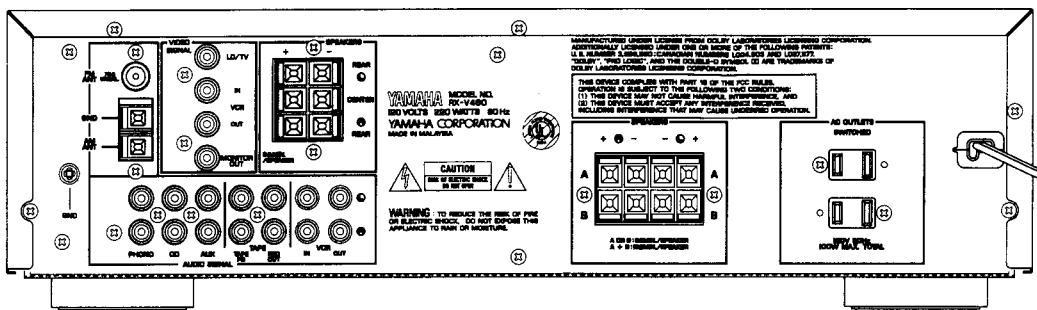

▼ RX-V480/R-V98 C model

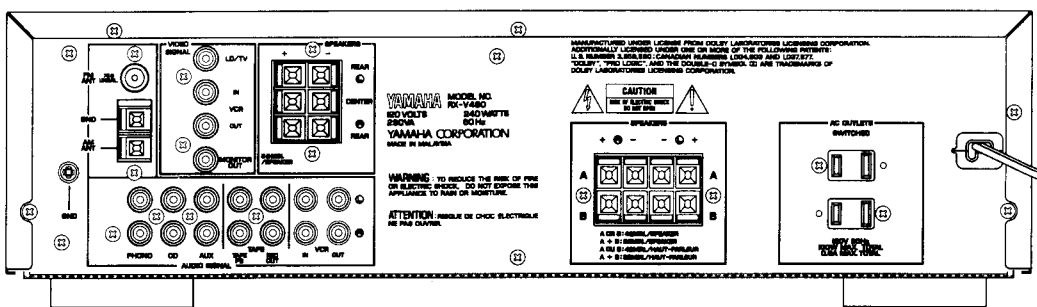

▼ RX-V480 R model

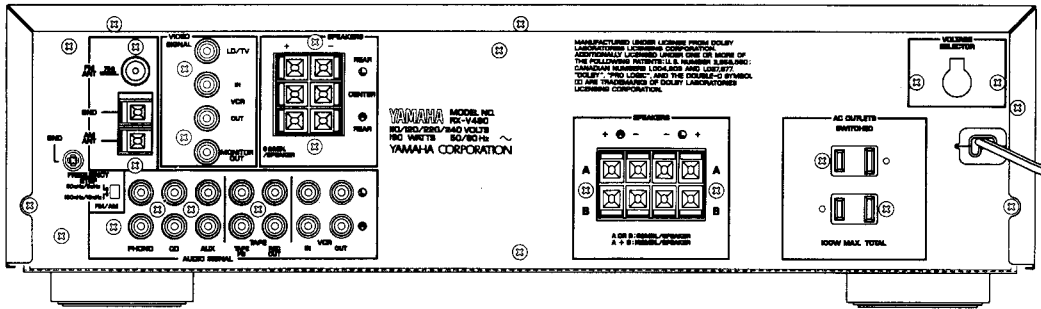

▼ RX-V480 A model

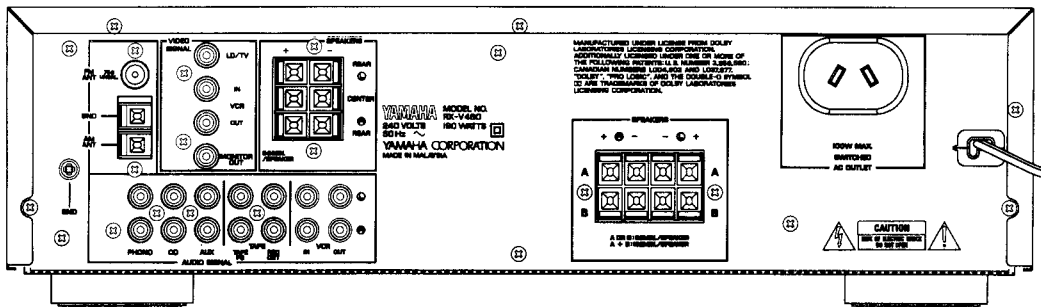

▼ RX-V480 B model

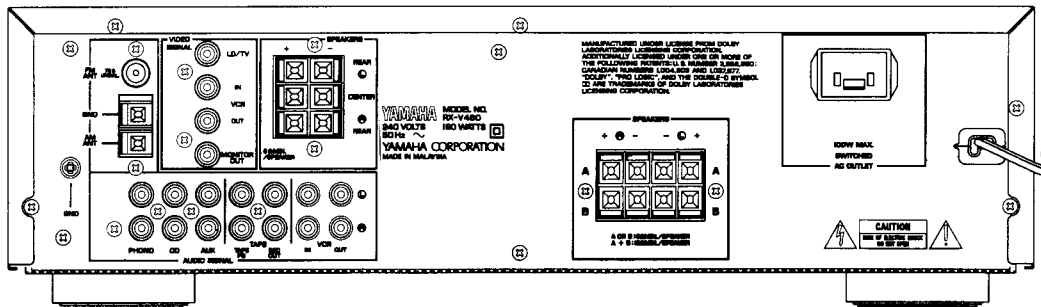

▼ RX-V480 G model

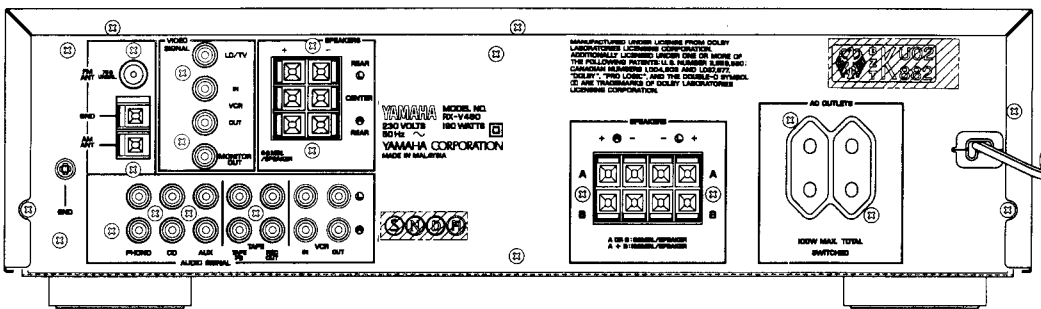

■ SPECIFICATIONS

■ AUDIO SECTION

Minimum RMS Output Power per Channel

RX-V480

FRONT, 20Hz to 20kHz, 0.04% THD, 8Ω

U model65W

C model55W

A, B, G, R models60W

CENTER, 1kHz, 0.1% THD, 8Ω

U model65W

C model55W

A, B, G, R models60W

REAR, 1kHz, 0.7% THD, 8Ω15W

R-V98

FRONT, 1kHz, 0.09% THD, 8Ω

U model80W

C model55W

CENTER, 1kHz, 0.1% THD, 8Ω

U model80W

C model55W

REAR, 1kHz, 0.7% THD, 8Ω15W

Dynamic Power per Channel (IHF)

RX-V480

8/6/4/2Ω

U model100/120/140/190W

C model80/100/120/140W

A, B, G, R models90/110/130/150W

R-V98

8/6/4/2Ω

U model110/140/190/220W

C model95/120/140/160W

DIN Standard Output Power per Channel **RX-V480**

4Ω, 1kHz, 0.7% THD

G model only70W

IEC Power **RX-V480** (1kHz, 0.04% THD, 8Ω)

G model only66W

Power Band Width

0.08% THD, 30W, 8Ω10Hz to 50kHz

Damping Factor

20Hz to 20kHz, 8Ω80

Maximum Power **RX-V480**

EIAJ, 1kHz, 10% THD, 8Ω

R model only90W

Input Sensitivity/Impedance

PHONO MM2.5mV/47kΩ

CD etc150mV/47kΩ

Maximum Input Signal Level (1kHz, 0.04% THD)

PHONO MM90mV

Output Level/Impedance

REC OUT150mV/600Ω

Headphone Jack Rated Output/Impedance

RX-V480

0.04% THD, RL=8Ω

U model0.54V/330Ω

C model0.49V/330Ω

A, B, G, R models0.52V/330Ω

R-V98

0.09% THD, RL=8Ω

U model0.51V/390Ω

C model0.42V/390Ω

Frequency Response (20Hz to 20kHz)

CD etc0±0.5dB

RIAA Equalization Deviation (20Hz to 20kHz)

PHONO MM0±0.5dB

Total Harmonic Distortion (20Hz to 20kHz)

PHONO MM to REC OUT (1V)0.02%

CD etc to SP OUT (30W/8Ω)0.02%

Signal-to-Noise Ratio (IHF-A Network)

PHONO MM (5mV Input Shorted)82dB

CD etc (Shorted)93dB

Residual Noise (IHF-A Network)140μV

Channel Separation (Vol. -30dB)

PHONO MM (Input Shorted) 1kHz60dB

CD etc (Input 5.1kΩ Terminated) 1kHz60dB

Tone Control Characteristics

BASS : Boost/cut±10dB (50Hz)

Turnover Frequency350Hz

TREBLE : Boost/cut±10dB (20kHz)

Turnover Frequency3.5kHz

Gain Tracking Error (0 to -60dB)3dB

■ VIDEO SECTION

Video Signal

Input Level/Impedance1Vp-p/75Ω

Output Level/Impedance1Vp-p/75Ω

■ FM SECTION

Tuning Range

U, C, R models87.5 to 107.9MHz

A, B, G, R models87.5 to 108.0MHz

50dB Quieting Sensitivity (IHF, 75Ω)

Except G model

Mono1.55μV (15.1dBf)

Stereo21μV (37.7dBf)

Usable Sensitivity (75Ω)

(30dB S/N Quieting, 1kHz, 100% mod.)

Except G model0.8μV (9.3dBf)

DIN, Mono (S/N 26dB) G model0.9μV

DIN, Stereo (S/N 46dB) G model24μV

Image Response Ratio

Except G model45dB

G model80dB

IF Response Ratio80dB

Spurious Response Ratio70dB

AM Suppression Ratio55dB

Capture Ratio1.5dB

Alternate Channel Selectivity

Except G model85dB

Selectivity (two signals, 40kHz Dev.)

G model70dB

Signal-to-Noise Ratio

(IHF) Mono/Stereo	
Except G model	80/75dB
(DIN-weighted, 40kHz Dev.) Mono/Stereo	
G model	74/69dB

Harmonic Distortion

Mono/Stereo, 1kHz (G : 40kHz Dev.)	0.1/0.2%
------------------------------------	----------

Frequency Response

20Hz to 15kHz	0±1.5dB
---------------	---------

Stereo Separation

1kHz (G : 40kHz Dev.)	50dB
-----------------------	------

AM SECTION

Tuning Range

U, C, R models	530 to 1,710kHz
A, B, G, R models	531 to 1,611kHz

Usable Sensitivity100µV/m

Selectivity32dB

Signal-to-Noise Ratio50dB

Image Response Ratio40dB

Spurious Response Ratio50dB

Harmonic Distortion (400Hz)0.3%

AUDIO SECTION

Output Level/Impedance

FM (100% mod., 1kHz)	
Except G model	500mV/2.2kΩ
G model (40kHz Dev.)	400mV/2.2kΩ
AM (30% mod., 400Hz)	
Except G model	150mV/2.2kΩ
G model	150mV/2.2kΩ

GENERAL

Power Supply

U, C models	AC 120V, 60Hz
A, B models	AC 240V, 50Hz
G model	AC 230V, 50Hz
R model	AC 110/120/220/240V, 60/50Hz

Power Consumption

RX-V480

U model	220W
C model	290VA/240W
A, B, G, R models	190W

R-V98

U model	220W
C model	345VA/240W

Maximum Power Consumption **RX-V480**

R model only	500W
--------------	------

AC Outlets

Switched x 2	
U, C, R, G models	100W max. (Total)
Switched x 1	
A, B models	100W max.

Dimensions (W x H x D)435 x 126 x 299mm
(17-1/8" x 4-15/16" x 11-3/4")

Weight

RX-V480

U, A, B, G, R models	8.5kg (18lbs 11oz)
C model	8.3kg (18lbs 4oz)

R-V98

U, C models	8.2kg (18lbs 1oz)
-------------	-------------------

AccessoriesAM loop antenna x 1
Indoor FM antenna x 1
Remote Control Transmitter x 1
Battery (size "AA", "R06") x 2

* Specifications subject to change without notice.

UUSA model	BBritish model
CCanadian model	GEuropean model
AAustralian model	RGeneral model

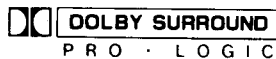

Manufactured under license from Dolby Laboratories Licensing Corporation. Additionally licensed under one or more of the following patents : U. S. number 3, 950, 590 ; Canadian numbers 1, 004, 603 and 1, 037, 877. "Dolby", "Pro Logic", and the double-D symbol are trademarks of Dolby Laboratories Licensing Corporation.

DIMENSIONS

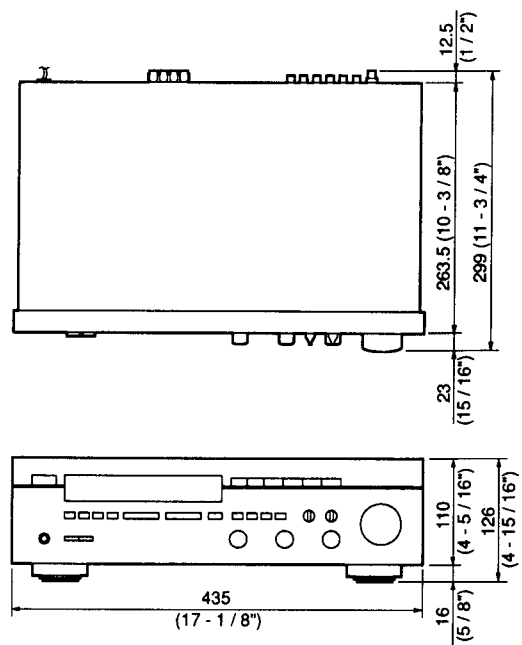

Units : mm (Inch)

INTERNAL VIEW

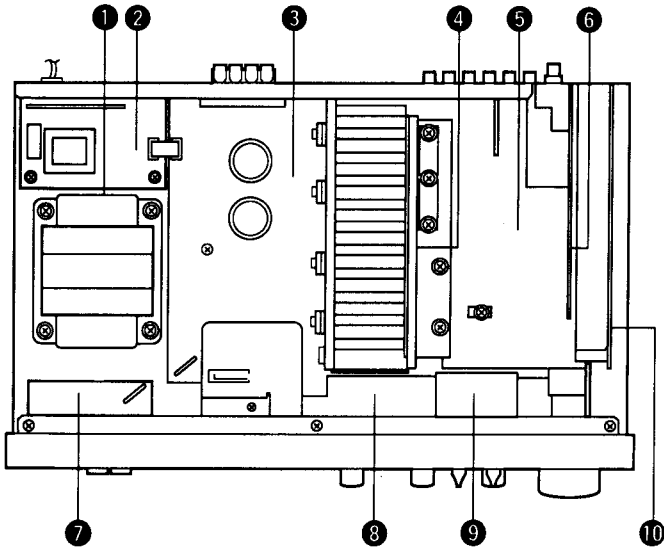

- ① POWER TRANSFORMER
- ② P. C. B. MAIN (2)
- ③ P. C. B. MAIN (1)
- ④ P. C. B. EFFECT (2)
- ⑤ P. C. B. INPUT
- ⑥ P. C. B. TUNER
- ⑦ P. C. B. MAIN (3)
- ⑧ P. C. B. OPERATION (2)
- ⑨ P. C. B. EFFECT (3)
- ⑩ P. C. B. EFFECT (1)

DISASSEMBLY PROCEDURES (Remove parts in the order as numbered.)

1. Removal of Top Cover

Remove 4 screws (①) and 3 screws (②) in Fig. 1.

2. Removal of Front Panel

- a. Remove 6 knobs.
- b. Remove 6 screws (③) in Fig. 1.

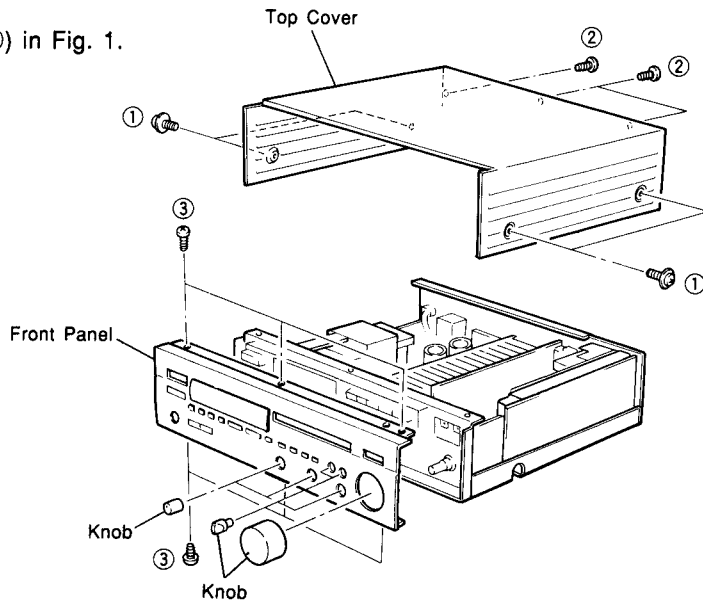

Fig. 1

3. Removal of Rear Panel

Remove 21 screws (④) in Fig. 2.

* The P. C. B. MAIN, INPUT, TUNER & EFFECT can be removed in this state.

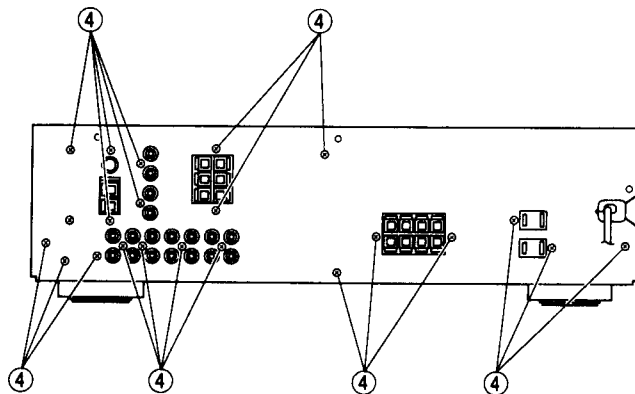

Fig. 2

■ TEST SIGNAL PROGRAM

To facilitate inspection and measurement, a test signal program is programmed in this set.

CAUTION : Using a table as shown below, write down the content of the memory preset in the tuner before setting to the test signal program mode.

(This is because setting to the test signal program mode sets the tuner memory content in the state preset by the manufacturer and erases all the memory preset by the user.)

Upon completion of the test signal program, set to the tuner mode again and enter the preset memory as written in the table.

Preset group	P1	P2	P3	P4	P5	P6	P7	P8
A								
B								
C								
D								
E								

1. Starting Operation

While pressing 2 keys of PHONO and CD simultaneously, turn ON the POWER switch, and the test signal program mode No.1 will start.

2. Functions available during the test signal program mode

In the test signal program mode, any operation other than those listed below is invalid.

- Selection key of diagnosis mode
- INPUT SELECTOR key : Switching input source
- POWER ON/OFF key : Power ON/OFF

TEST PROGRAM 1. — LCD&INITIALIZE

When the TEST program procedure is started, all LCD's turn ON, the set is initialized and the content as preset by the manufacturer is executed.

Then, when MEMORY key is pressed once, "P1" appears in the LCD after a few seconds.

- INPUT : CD
- MONITOR OUT : LD
- SURROUND : PRO LOGIC

Note : To restore the TEST program 1 from any other TEST program, press the MEMORY key.

TEST PROGRAM 2. — LED & INHIBIT

The TEST program 2 checks the input switching function. When the EDIT key is pressed, "P2" appears in the LCD and the input selector switches automatically. When the operation stops, the LCD turns OFF.

LCD : Lighting occurs in the order of PHONO, CD, TUNER, TAPE MONITOR, VCR MONITOR, LD after the above display, the LCD turns OFF.

TEST PROGRAM 3.

The TEST program 3 is not programmed in this set.

TEST PROGRAM 4. — STEERING OFF

Press the FM/AM key

The MULTIPLYING DAC value in the DSP-LSI output step is removed from control by the internal direction emphasis circuit and now can be set through the microcomputer. The output of each channel is as listed below.

- LEFT : L signal
- RIGHT : R signal
- CENTER : L, R in-phase component
- REAR : L, R negative phase component

The LCD displays "P4 CD".

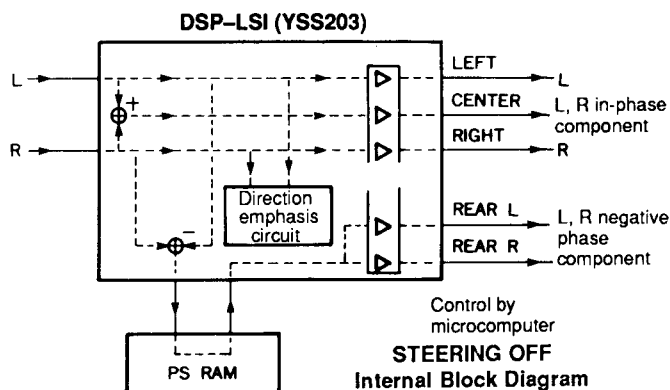

TEST PROGRAM 5. — RAM THROUGH

The TEST program 5 checks the output of each channel
Press the TUNING DOWN key

The L and R channels enter the through state and (L + R)/2 is output at the CENTER and REAR.

The LCD displays "P5 CD".

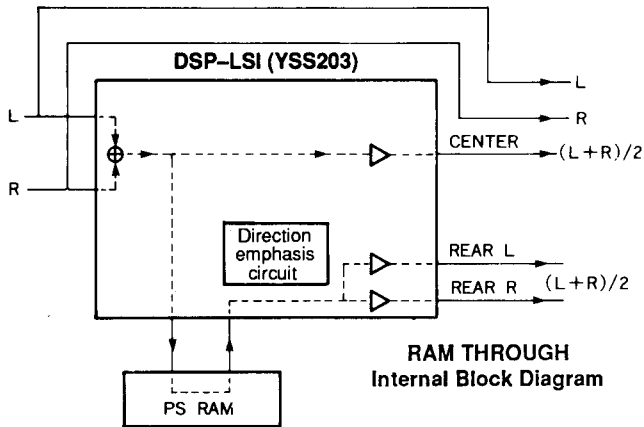

TEST PROGRAM 6. — Not performed

As the TEST program 6 is not intended for servicing, do not perform it.

Note : When the TUNING UP key is pressed by mistake, "P6" appears in the LCD. This is meaningless for self-diagnosis function. If this has occurred by accident, do not proceed with other TEST programs. Turn OFF the power once and then restart the TEST program procedure.

TEST PROGRAM 7. — MANUAL TEST TONE

Press the TEST Key

The TEST tone of the DOLBY PRO LOGIC shifts in the order of L C R S (Surround) at every pressing of the TEST key. Also, the LCD displays "TEST" and the TEST output position ("L", "C", "R" or "S").

Example) "TEST L"

TEST PROGRAM 8. — EXIT

Press the EFFECT Key

The program exits the self diagnosis mode and reenters the normal operation mode as factory-set.

3. Cancellation

The program is reset to the normal operation mode by turning the power OFF or by pressing the EFFECT key. At the same time, the "maker preset" is also executed.

● **Maker Preset**

1) TUNER section

Preset group	P1	P2	P3	P4	P5	P6	P7	P8
A, C, E	87.5MHz	90.1MHz	95.1MHz	98.1MHz	U, C : 107.9MHz R, A, B, G : 108.0MHz	88.1MHz	106.1MHz	U, C : 107.9MHz R, A, B, G : 108.0MHz
B, D	630kHz	1080kHz	1440kHz	U, C : 530kHz R, A, B, G : 531kHz	U, C : 1710kHz R, A, B, G : 1611kHz	900kHz	1350kHz	U, C : 1400kHz R, A, B, G : 1404kHz

All tuning modes are AUTO TUNING and AUTO STEREO.

2) SURROUND section

- DELAY TIME : PRO LOGIC20ms (Factory-set surround mode)
- ENHANCED20ms
- CONCERT VIDEO25ms
- MONO MOVIE25ms
- ROCK CONCERT15ms
- CONCERT HALL30ms
- CENTER MODE : NORMAL

3) SELECTOR section

- INPUT : CD
- MONITOR OUT : LD

ADJUSTMENTS

Measuring Instruments

- FM signal generator (FM SG)
- Stereo signal generator (SSG)
- AM signal generator (AM SG)
- Distortion meter (DIST. M)
- AC voltmeter (ACVM)
- DC voltmeter (DCVM)
- Oscilloscope
- Low pass filter (YLF-15, $f_c=15\text{kHz}$)
- Oscillator

Dummy antenna

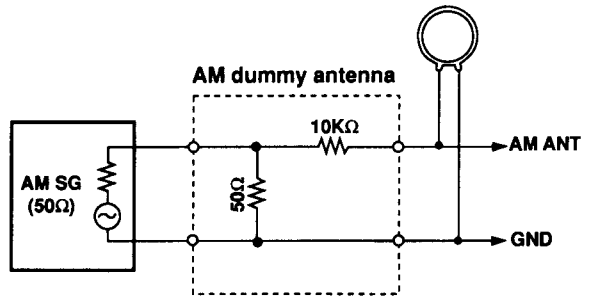
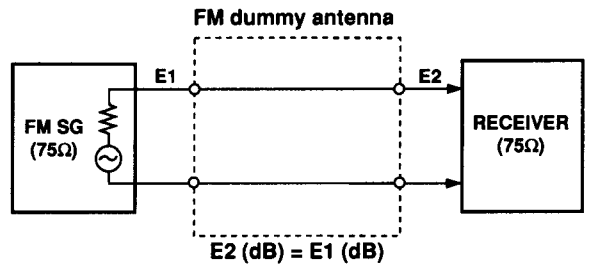
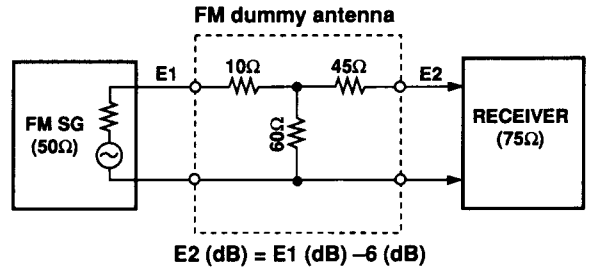

TEST POINT

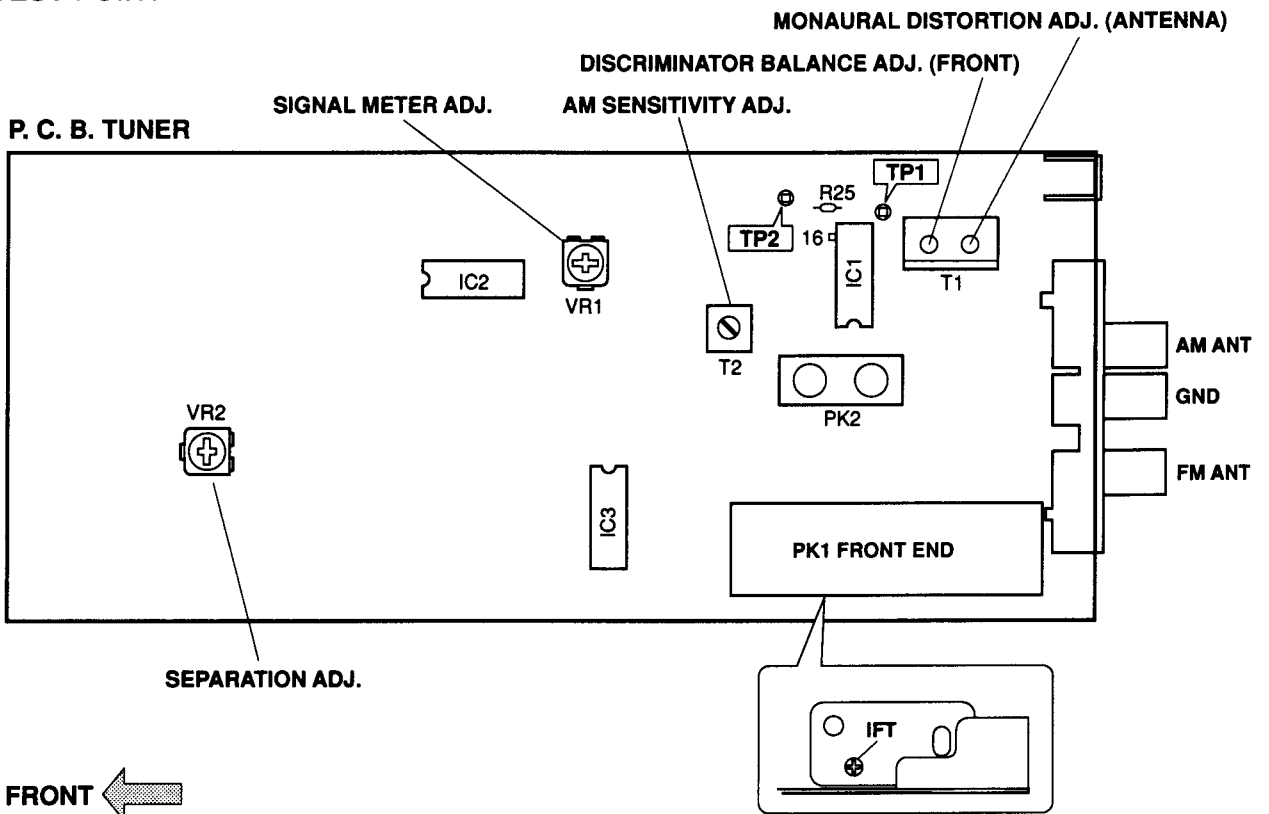

FM Adjustment

● Before Adjustment

1) For dB, $1\mu V = 0dB\mu$ applies.
 Example : $60dB\mu = 1mV$

2) 100% modulation means that the frequency deviation is 75kHz.

3) Install the Matching Transformer and connect FM SG.

4) Set each switch at the following position unless otherwise specified.

INPUT SELECTOR TUNER
 TUNING MODE AUTO

● Connection diagram (Measuring instruments)

1) Discriminator balance adjustment

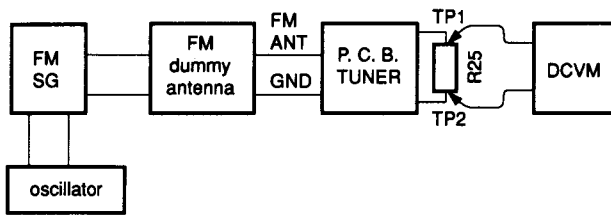

3) Stereo distortion verification/separation adjustment

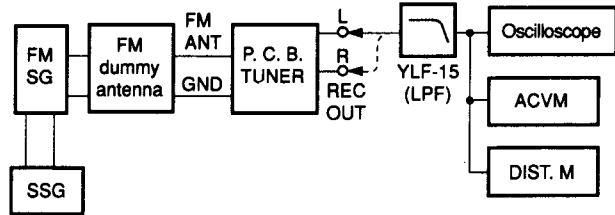

2) Monaural distortion adjustment

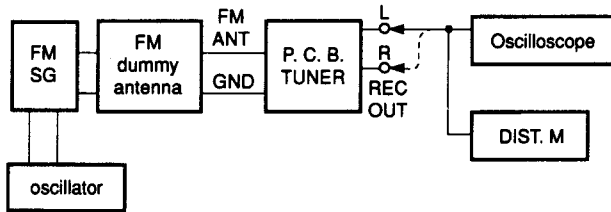

4) Sensitivity Verification

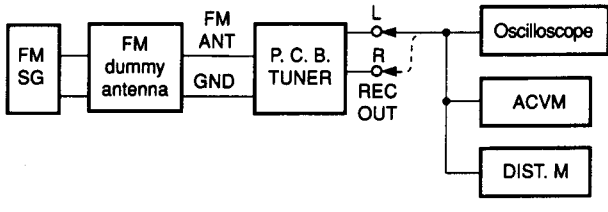

See page 8 for TP locations & adjustment points.

Step	Adjustment Item	Signal (ANT IN)	Reception frequency	Adjustment point	Test point	Rating
1	Rough adjustment of discriminator balance	FM ANT (75Ω) 98.1MHz 70dBμ MONO 100Hz 100% modulation	98.1MHz * (A-4)	T1 (Front side core)	Both ends of R25 (Between TP1 and TP2)	DC 0V±100mV
2	Rough adjustment of monaural distortion	Same as Step 1.	98.1MHz * (A-4)	T1 (Antenna side core)	REC OUT L, R	Minimize the distortion.
3	Fine adjustment of discriminator balance	Same as Step 1.	98.1MHz * (A-4)	T1 (Front side core)	Both ends of R25 (Between TP1 and TP2)	DC 0V±50mV
4	Fine adjustment of monaural distortion	Same as Step 1.	98.1MHz * (A-4)	T1 (Antenna side core)	REC OUT L, R	Minimize the distortion (to 0.25% or less).
5	Verification of discriminator balance	Same as Step 1.	98.1MHz * (A-4)	T1 (Front side core)	Both ends of R25 (Between TP1 and TP2)	DC 0V±50mV

* : Execution of MAKER PRESET (Refer to TEST SIGNAL PROGRAM on pages 6 and 7.) will facilitate setting reception frequency for adjustment.

Step	Adjustment Item	Signal (ANT IN)	Reception frequency	Adjustment point	Test point	Rating
6	Adjustment of frontend IFT	FM ANT (75Ω) 98.1MHz 30dBμ MONO 1kHz, 100% modulation	98.1MHz * (A-4)	Front end IFT	Pin 16 of IC1	Adjust so that the DC voltage is maximum. CAUTION : Over-adjustment of the IFT core will reduce the sensitivity. Maximum ±90°
7	Verification of monaural distortion	FM ANT (75Ω) 98.1MHz 70dBμ MONO 1kHz, 100% modulation	98.1MHz * (A-4)		REC OUT L, R	0.4% or less
8	Verification of stereo distortion	FM ANT (75Ω) 98.1MHz 70dBμ Stereo L or R 1kHz, 100% modulation	98.1MHz * (A-4) Tuning mode should be AUTO		REC OUT L, R	1% or less • STEREO indicator should light.
9	Verification of sensitivity	FM ANT (75Ω) 88.1MHz 98.1MHz 106.1MHz	88.1MHz * (A-6) 98.1MHz * (A-4) 106.1MHz * (A-7)		ANT (75Ω)	Set the tuning mode to MAN'L MONO. S/N should be 30dB at each frequency of 88.1MHz, 98.1MHz, and 106.1MHz. Check to ensure that the voltage at the ANT terminal is 3dBμ (14.25dBf) or less.
10	Adjustment of Separation	FM ANT (75Ω) 98.1MHz 70dBμ Stereo L or R 1kHz, 100% modulation	98.1MHz * (A-4)	VR2	REC OUT L, R	With SSG output at L or R, the signal leakage level at the other channel should be minimized. 36dB or more
11	Adjustment of signal meter	FM ANT (75Ω) 98.1MHz 45dBμ MONO 1kHz 30% modulation	98.1MHz * (A-4)	VR1		Adjust so that all signal meters light.
		-10dBμ or less				Check to ensure that signal meters turn OFF.
12	Verification of auto tuning	FM ANT (75Ω) 98.1MHz 23dBμ Stereo L or R 1kHz, 30% modulation	98.1MHz			<ul style="list-style-type: none"> • Automatic reception should be available when the tuning key is moved UP and DOWN. • The stereo indicator should light. • Audio muting should be applied during tuning.

* : Execution of MAKER PRESET (Refer to TEST SIGNAL PROGRAM on pages 6 and 7.) will facilitate setting reception frequency for adjustment.

AM Adjustment (This should be done after FM adjustment.)

● **Connection Diagram (Measuring instruments)**

1) Adjustment of sensitivity

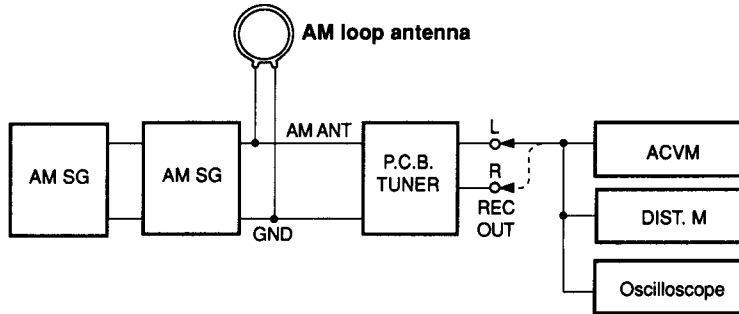

See page 8 for TP locations & adjustment points.

Step	Adjustment item	Signal (ANT IN)	Reception frequency	Adjustment point	Test point	Rating
1	Adjustment of sensitivity (1440kHz)	AM ANT 1440KHZ 50dB μ 400Hz, 30% modulation	1440kHz *(B-3)	T2	REC OUT	Audio output should be maximized.
2	Adjustment of sensitivity (630kHz)	AM ANT 630KHZ 50dB μ 400Hz, 30% modulation	630kHz *(B-1)	T2	REC OUT	Audio output should be maximized. Repeat the Step 1 and 2.
3	Verification of sensitivity	AM ANT 630KHZ 1080kHz 1440kHz 400Hz, 30% modulation	630kHz *(B-1) 1080kHz *(B-2) 1440kHz *(B-3)		AM ANT	Distortion should be 10% or less at each frequency. Check to ensure that the voltage at the ANT terminal is 54dB μ or less.
4	Verification of auto tuning	AM ANT 60dB μ				Auto reception should be available when the tuning key is pressed UP and DOWN.

Idling Current Adjustment

● **Confirmation of idling current. (Main section)**

After power is turned on, confirm that the voltages across R137 (L ch), R138 (R ch) are between 0.1mV~5mV.

If they exceeds 5.1mV, open (cut off) R131(L ch), R132 (R ch) and reconfirm voltage is between 0.1mV~5mV.

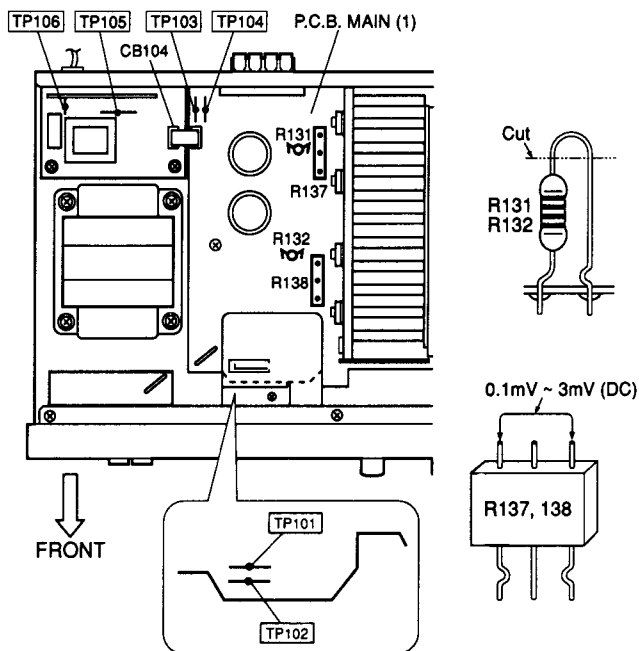

Fig. A

● **Checking and Parts Replacement of P. C. B. MAIN (1).**

- a. Disconnect the power cord from the AC outlet.
- b. Remove 5 screws fixing the Speaker terminals and Heat Sink.
- c. Remove 4 screws fixing the Main Unit.
- d. Detach 1 connector terminal (CB104) in Fig. A.
- e. Place the Main Unit on its side as shown in Fig. B.
- f. Operating checks can be taken by shorting between following test points in Fig. A.

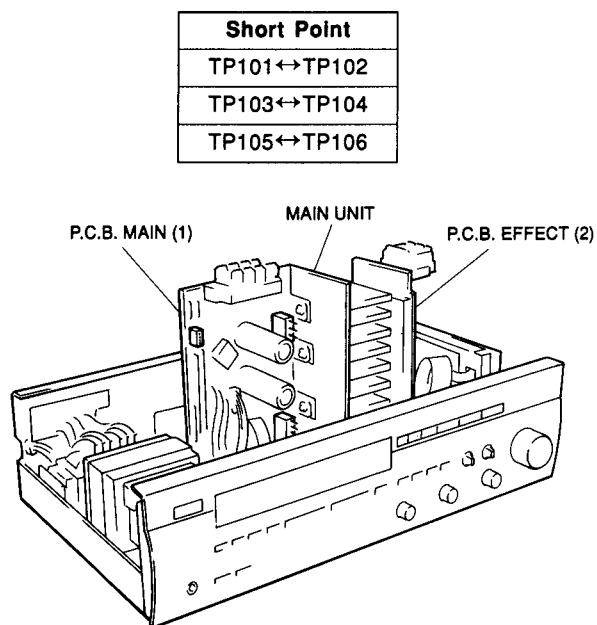

Fig. B

● **Confirmation of idling current. (Effect section)**

In the same way, confirm that the voltage across R828 is within 5mV.

If it exceeds 5mV, open (cut off) R831 and reconfirm it's within 5mV.

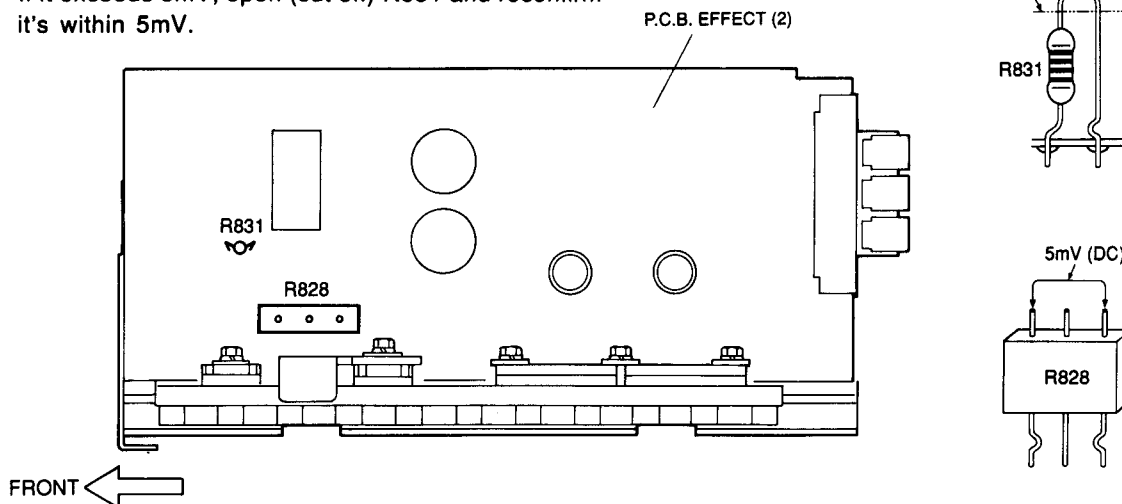
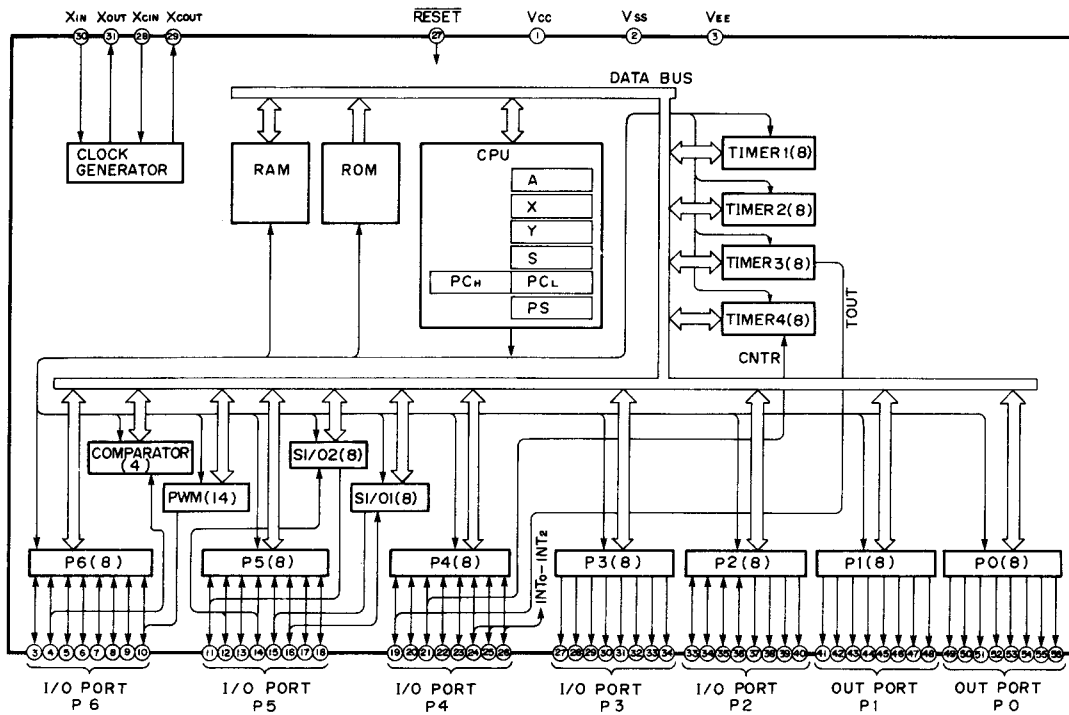
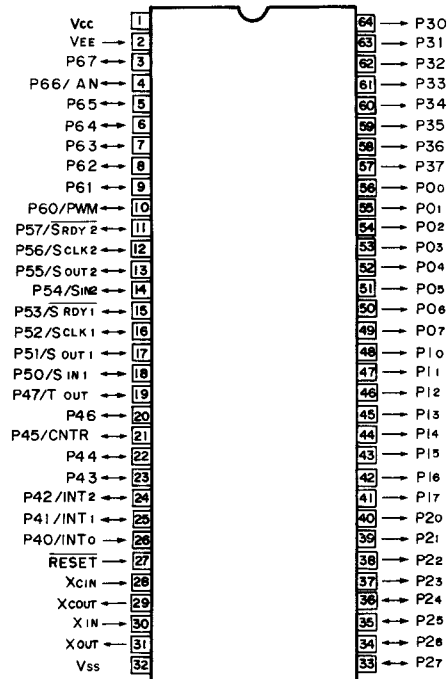

Fig. C

■ IC DATA

IC301 : M38102M4-614SP
8 bit μ -COM



Pin No.	Port	Name	I/O	Function
1	Vcc	VCC		+5V
2	Vee	-VEE		-25V
3	P67	PROTEC	I	Protection detect
4	P66	METER	I	Tuner meter
5	P65	V1	I	Market select
6	P64	V2	I	
7	P63	V3	I	
8	P62	PDDET	I	Power down detect

Pin No.	Port	Name	I/O	Function
9	P61	STBY	O	LED for STAND BY
10	P60	PWRLY	O	Power switch drive
11	P57	FMUTE	O	Front mute
12	P56	CLKOUT2	O	Serial clock out to BU2040
13	P55	DATA2	O	Serial data out to BU2040
14	P54	SIGIN	I	Synchronous signal in
15	P53	STEREO	I	Stereo detect
16	P52	CLKOUT1	O	Serial clock out to LM7000N, NJU7313, YSS203
17	P51	DATA1	O	Serial data out to LM7000N, NJU7313, YSS203
18	P50	CETUN	O	Chip select for LM7000N
19	P47	STPOUT	I	Auto tuning stop signal
20	P46	SEL	I	DSP select
21	P45	CEDSP	O	Chip select for DSP
22	P44	CEFSR	O	Chip select for NJU7313
23	P43	EFFMT	O	Effect IC mute (IC802, 803)
24	P42	CNTMUT	O	Center mute
25	P41	REARMT	O	Rear mute
26	P40	REMIN	I	Remote control signal input
27	RESET	RESET	—	Reset
28	XCI	(NC)	—] N. C.
29	XCO	(NC)	—	
30	XIN	XIN	—] Clock (4MHz)
31	XOUT	XOUT	—	
32	VSS	VSS	—	GND
33	P27	K4	I] Key input
34	P26	K3	I	
35	P25	K2	I	
36	P24	K1	I	
37	P23	D5	O] Key scan digit
38	P22	D4	O	
39	P21	D3	O	
40	P20	D1	O	
41	P17	SG1	O] Fluorescent character display tube anode drive signal
42	P16	SG2	O	
43	P15	SG3	O	
44	P14	SG4	O	
45	P13	SG5	O	
46	P12	SG6	O	
47	P11	SG7	O	
48	P10	SG8	O	
49	P07	D2	O] Key scan digit
50	P06	(NC)	—] N. C.
51	P05	(NC)	—	
52	P04	G1	O] Fluorescent character display tube grid drive signal
53	P03	G2	O	
54	P02	G3	O	
55	P01	G4	O	
56	P00	G5	O	
57	P37	G6	O	
58	P36	G7	O	
59	P35	G8	O	
60	P34	G13	O	
61	P33	G12	O	
62	P32	G11	O	
63	P31	G10	O	
64	P30	G9	O	

	D1	D2	D3	D4	D5
K1	PHONO	TAPE	TUNING UP	PRESET UP	EFFECT ON/OFF
K2	CD	VCR	TUNING DOWN	PRESET DOWN	TEST
K3	TUNER	MEMORY	AUTO/MANUAL	DSP UP	POWER
K4	LD	A/B/C/D/E	FM/AM	DSP DOWN	EDIT

IC703 : YSS203B-F

Digital Dolby Pro Logic Decoder with Auto Input Balance

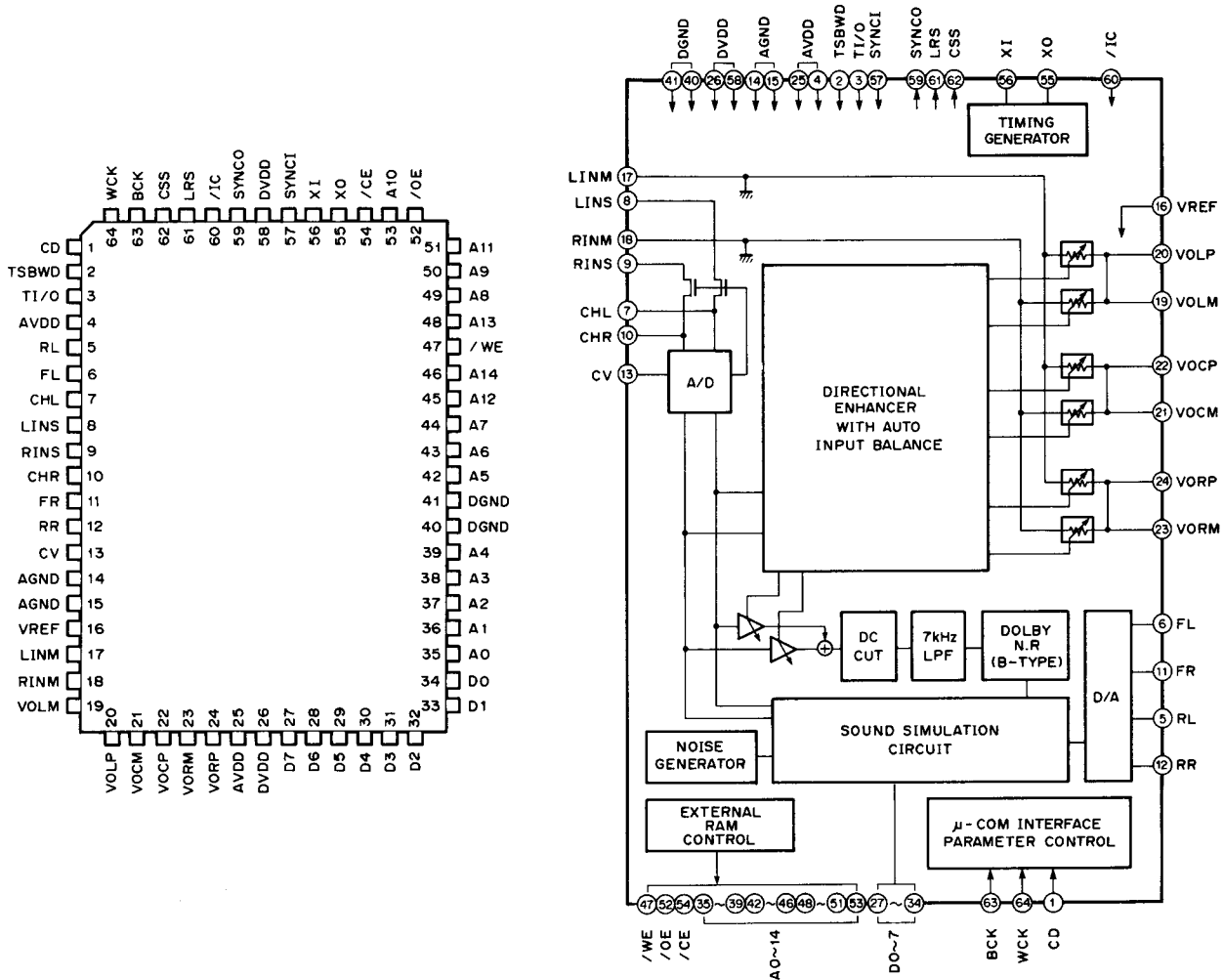

Pin No.	Pin Name	I/O	Function
1	CD	I _{ts}	Serial data of parameter data input
2	TSBWD	I _c	LSI test terminal Normally connected to DVDD
3	TI/O	I _c	LSI test terminal Normally connected to /CSS terminal
4	AVDD	A—	+5V power supply (D/A, A/D section)
5	RL	AO	RL channel D/A output
6	FL	AO	FL channel D/A output
7	CHL	A—	LINS input Sample/hold Capacitor external terminal
8	LINS	AI	L channel A/D input
9	RINS	AI	R channel A/D input
10	CHR	A—	RINS input Sample/hold Capacitor external terminal
11	FR	AO	FR channel D/A input
12	RR	AO	RR channel D/A input
13	CV	AO	A/D, multiplying DAC center voltage
14	AGND	A—	Ground (D/A, A/D section)
15	AGND	A—	Ground (Multiplying DAC section)
16	VREF	AI	Multiplying DAC reference voltage input
17	LINM	AI	L channel Multiplying DAC input
18	RINM	AI	R channel Multiplying DAC input
19	VOLM	AO	L channel operation amplifier, connected to (-) terminal
20	VOLP	AO	L channel operation amplifier, connected to (+) terminal

Pin No.	Pin Name	I/O	Function
21	VOCM	AO	C channel operation amplifier, connected to (-) terminal
22	VOCP	AO	C channel operation amplifier, connected to (+) terminal
23	VORM	AO	R channel operation amplifier, connected to (-) terminal
24	VORP	AO	R channel operation amplifier, connected to (+) terminal
25	AVDD	A—	+5V power supply (multiplying DAC section)
26	DVDD	—	+5V power supply (digital section)
27	D7	I/Ot	External delay RAM data terminal
28	D6	I/Ot	External delay RAM data terminal
29	D5	I/Ot	External delay RAM data terminal
30	D4	I/Ot	External delay RAM data terminal
31	D3	I/Ot	External delay RAM data terminal
32	D2	I/Ot	External delay RAM data terminal
33	D1	I/Ot	External delay RAM data terminal
34	D0	I/Ot	External delay RAM data terminal
35	A0	O	External data RAM address terminal
36	A1	O	External data RAM address terminal
37	A2	O	External data RAM address terminal
38	A3	O	External data RAM address terminal
39	A4	O	External data RAM address terminal
40	DGND	—	Ground (digital section)
41	DGND	—	Ground (digital section)
42	A5	O	External data RAM address terminal
43	A6	O	External data RAM address terminal
44	A7	O	External data RAM address terminal
45	A12	O	External data RAM address terminal
46	A14	O	External data RAM address terminal
47	/WE	O	External delay RAM write enable terminal
48	A13	O	External delay RAM address terminal
49	A8	O	External delay RAM address terminal
50	A9	O	External delay RAM address terminal
51	A11	O	External delay RAM address terminal
52	/OE	O	External delay RAM output enable terminal
53	A10	O	External delay RAM address terminal
54	/CE	O	External delay RAM chip enable terminal
55	XO	O	Crystal oscillator connecting terminal
56	XI	I	Crystal oscillator connecting terminal
57	SYNCI	It	Test terminal for system synchronization, normally connected to DVDD
58	DVDD	—	+5V power supply (digital section)
59	SYNCO	O	Test terminal for system synchronization, normally unconnected
60	/IC	Ics	Initial clear terminal (Power ON resetting is necessary)
61	LRS	O	External automatic input balance terminal, normally left open
62	/CSS	O	External automatic input balance terminal, connected to TI/O terminal
63	BCK	I _{ts}	Bit clock for parameter data input
64	WCK	I _{ts}	Word clock for parameter data input

Note : Alphabets used in the above I/O column represent as follows.

I : Input terminal O : Output terminal t : TTL level
C : CMOS level S : Schmidt input A : Analog terminal

■ BLOCK DIAGRAM (TUNER)

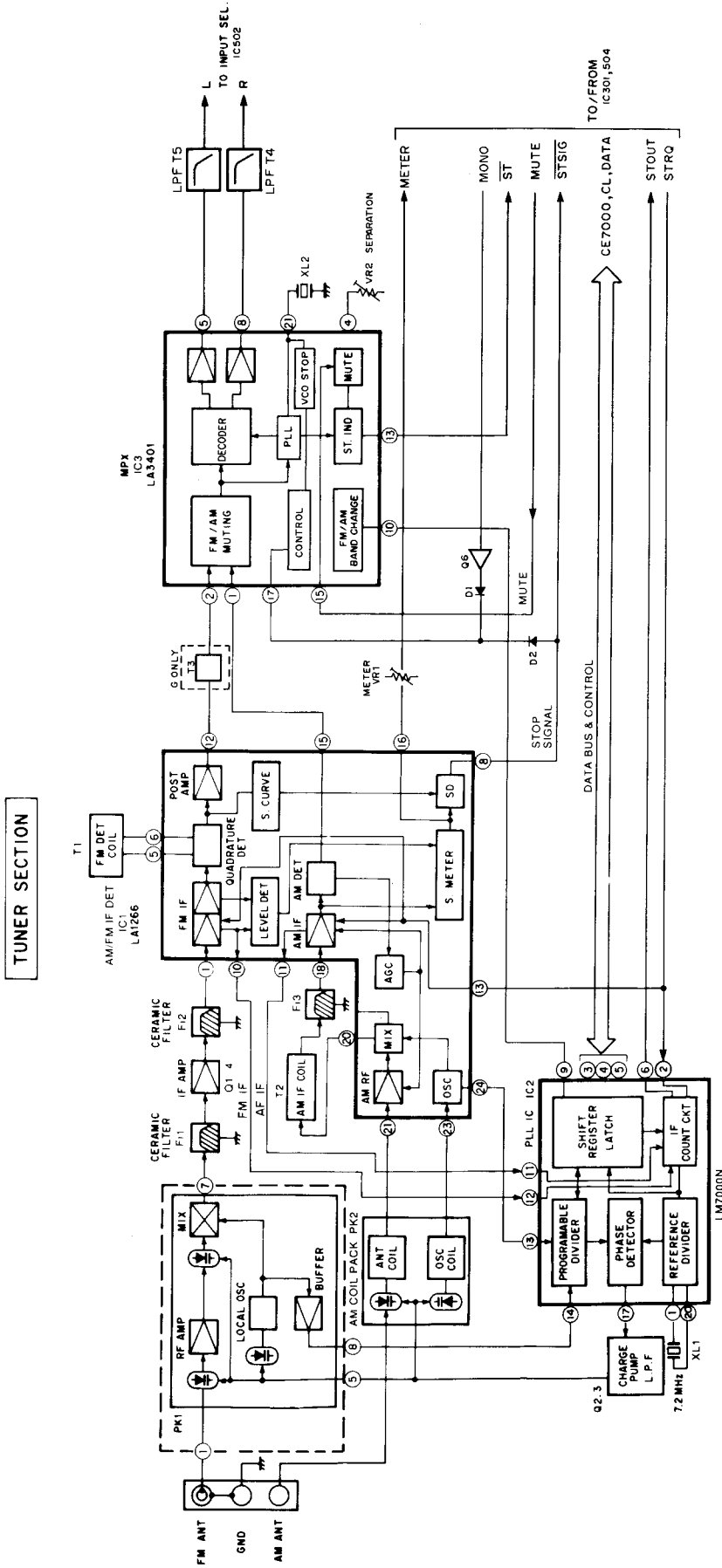

TUNER SECTION

■ BLOCK DIAGRAM (MAIN, EFFECT & OPERATION)

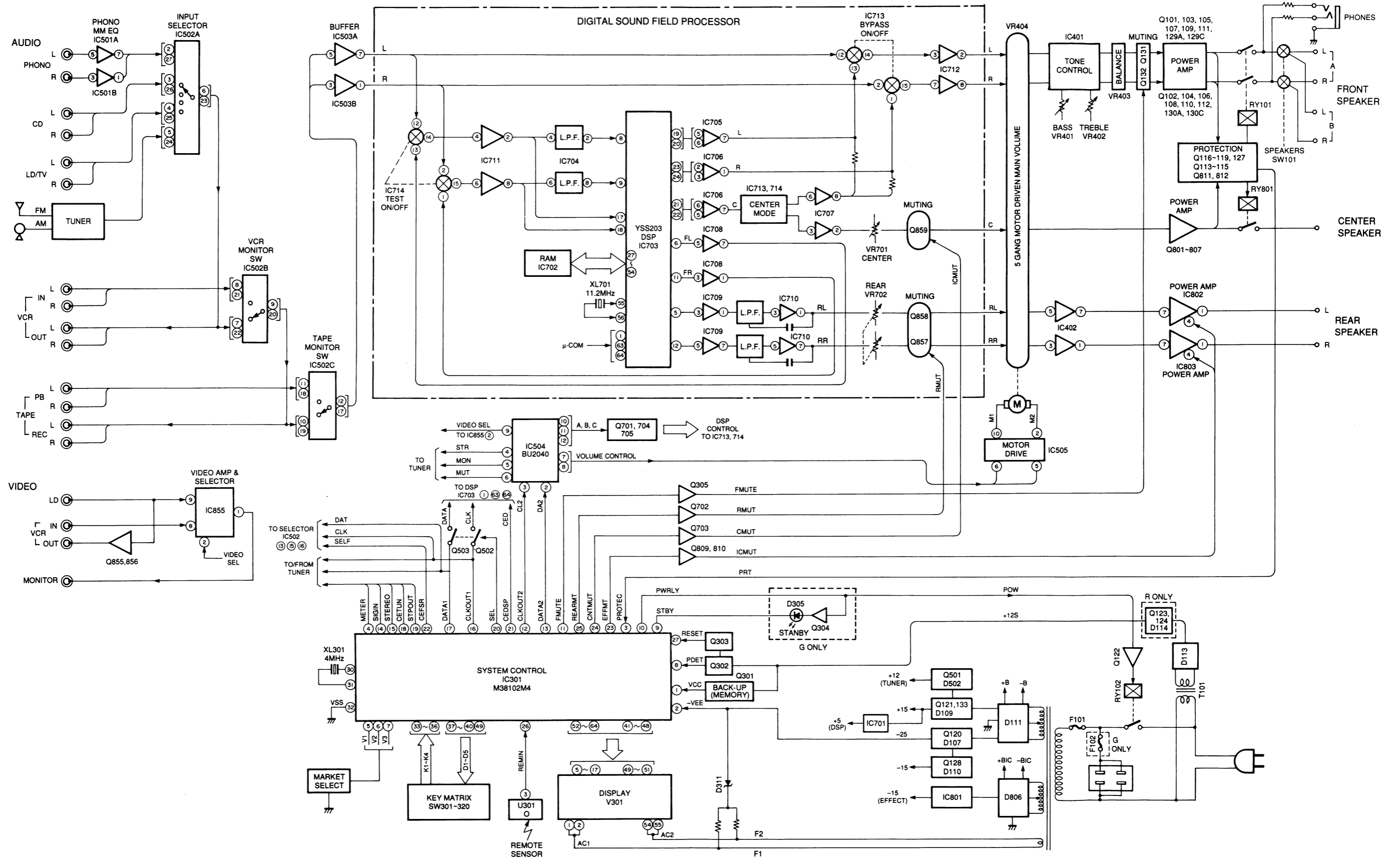

■ PRINTED CIRCUIT BOARD (Foil side)

① and ④ : TEST POINT WAVEFORMS (See page 31)

● Semiconductor Location

Ref No.	Location	Ref No.	Location
Q1	F2	IC1	E3
Q2	E2	IC2	D3
Q3	E2	IC3	E2
Q4	F2	IC701	D4
Q5	E2	IC702	D4
Q6	F2	IC703	C5
Q7	D3	IC704	C5
Q701	B5	IC705	C5
Q702	B5	IC706	D5
Q703	B5	IC707	D6
Q704	A5	IC708	C5
Q705	B5	IC709	C4
		IC710	B4
		IC711	B5
		IC712	B5
		IC713	C6
		IC714	B6

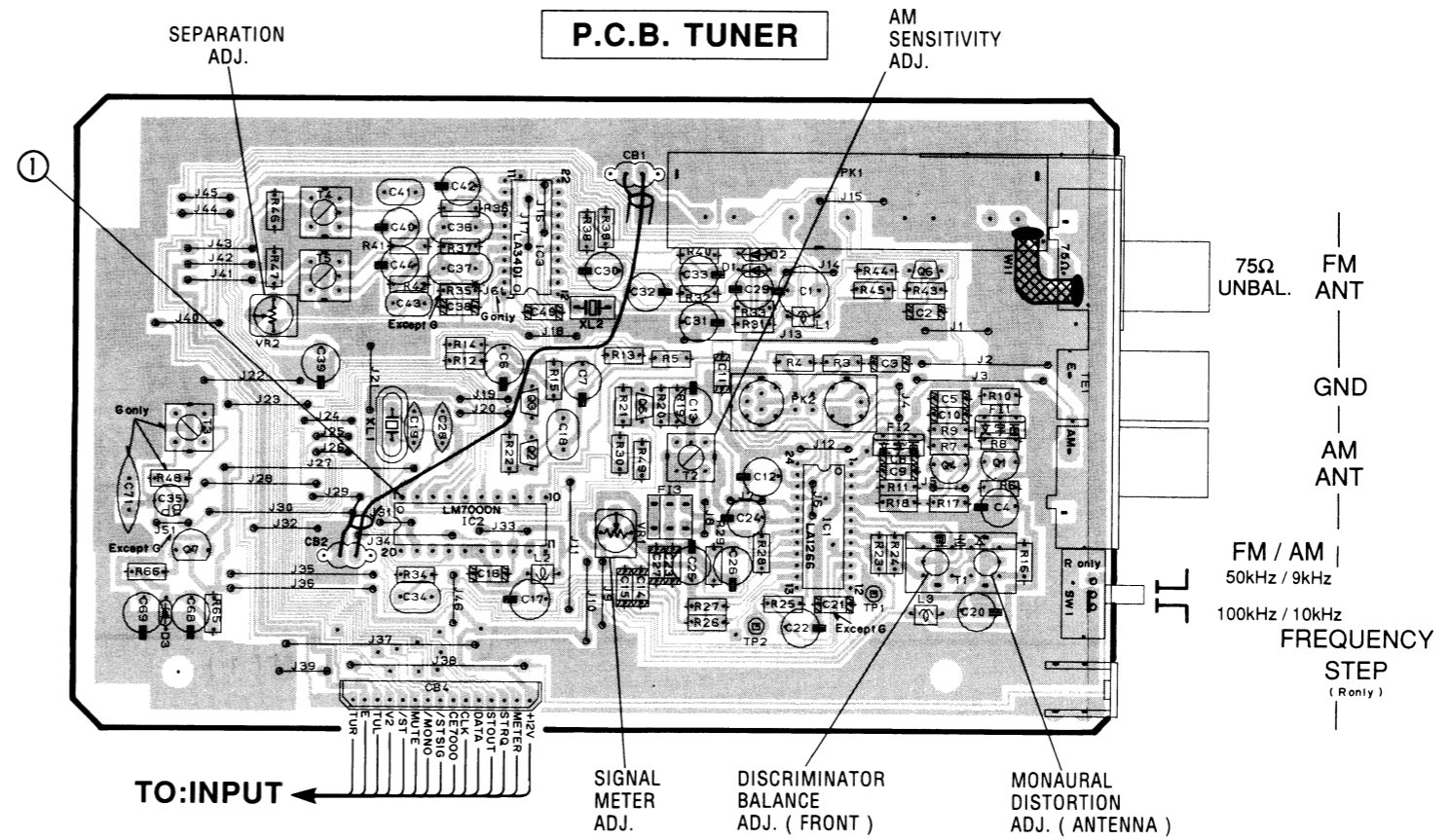

P.C.B. EFFECT (1)

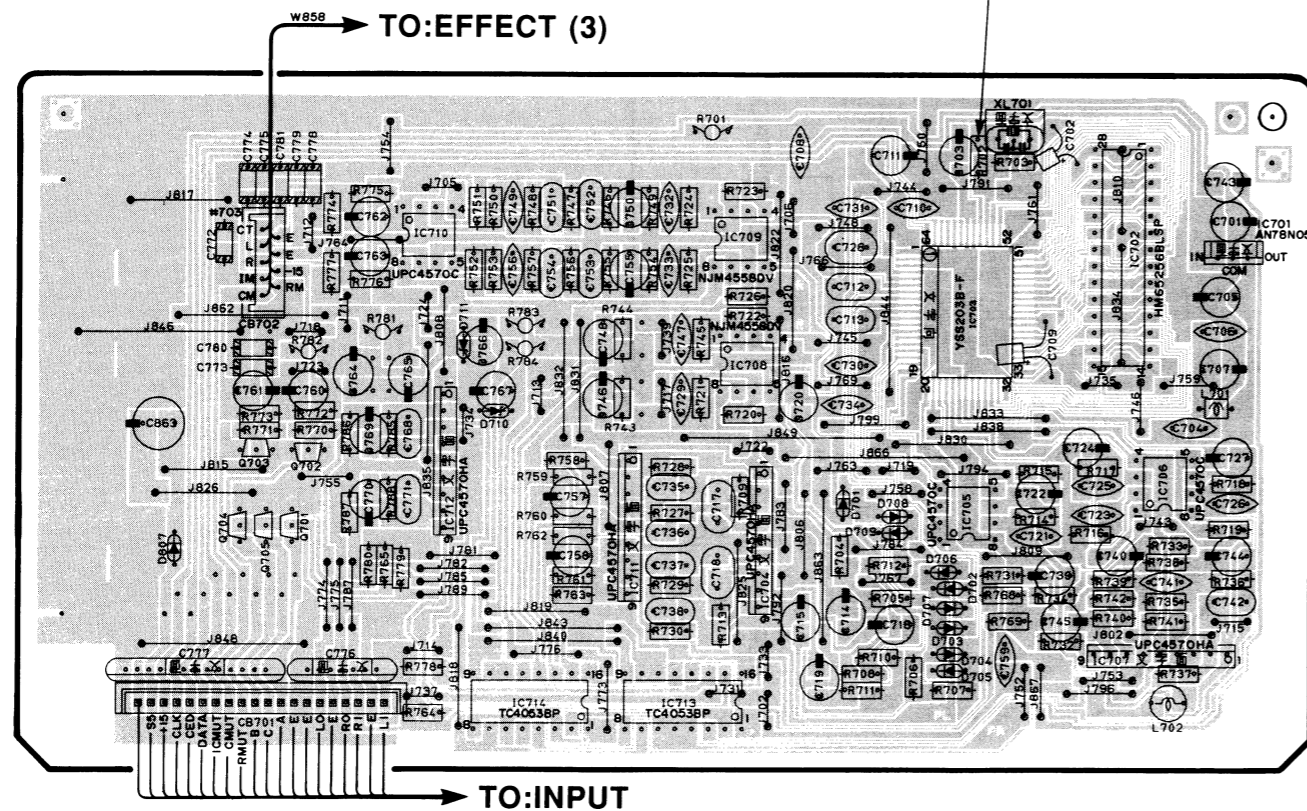

P.C.B. EFFECT (3)

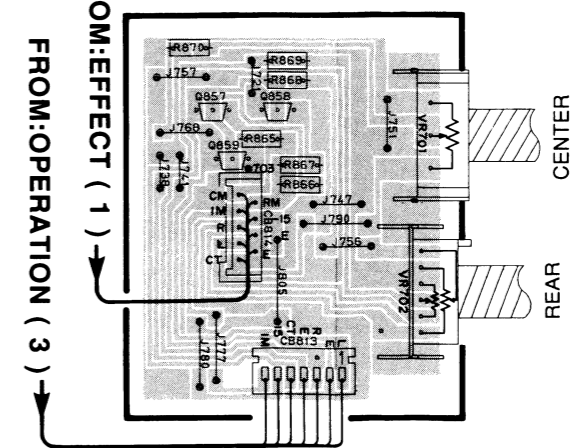

PRINTED CIRCUIT BOARD (Foil side)

● Semiconductor Location

Ref No.	Location
IC501	E4
IC502	E5
IC503	D5
IC504	C5
IC505	C5
IC801	D3
IC802	D2
IC803	E2

Ref No.	Location
Q501	D4
Q502	C4
Q503	C4
Q801	C2
Q802	C2
Q803	C2
Q804	C2
Q805A	C2
Q805C	C2
Q806	C2
Q807	C3
Q809	D3
Q810	D3
Q811	C2
Q812	C2

P.C.B. EFFECT (2)

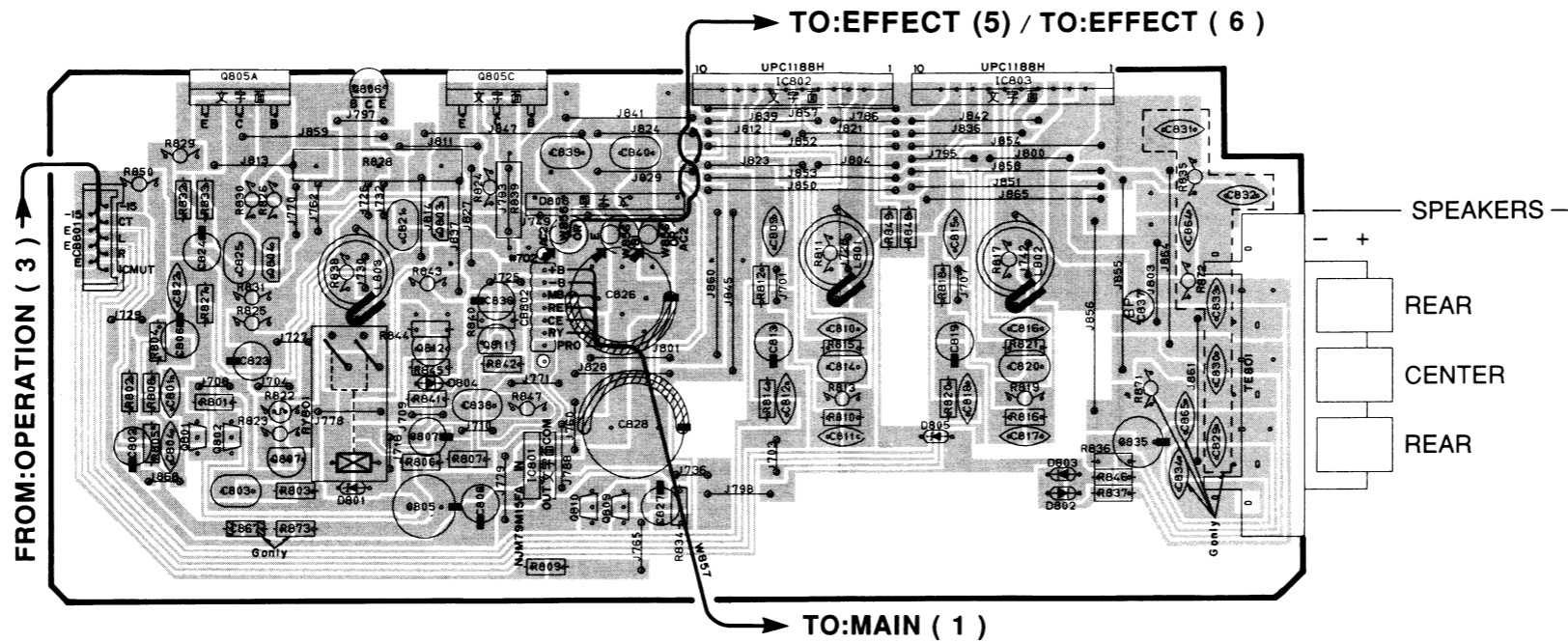

● U, C models

P.C.B. EFFECT (5)

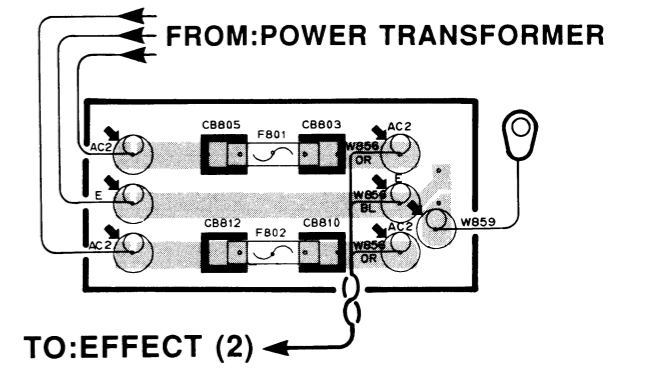

● R, A, B, G models

P.C.B. EFFECT (6)

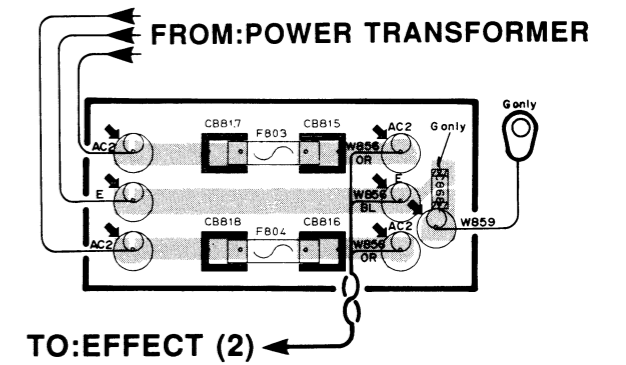

P.C.B. INPUT

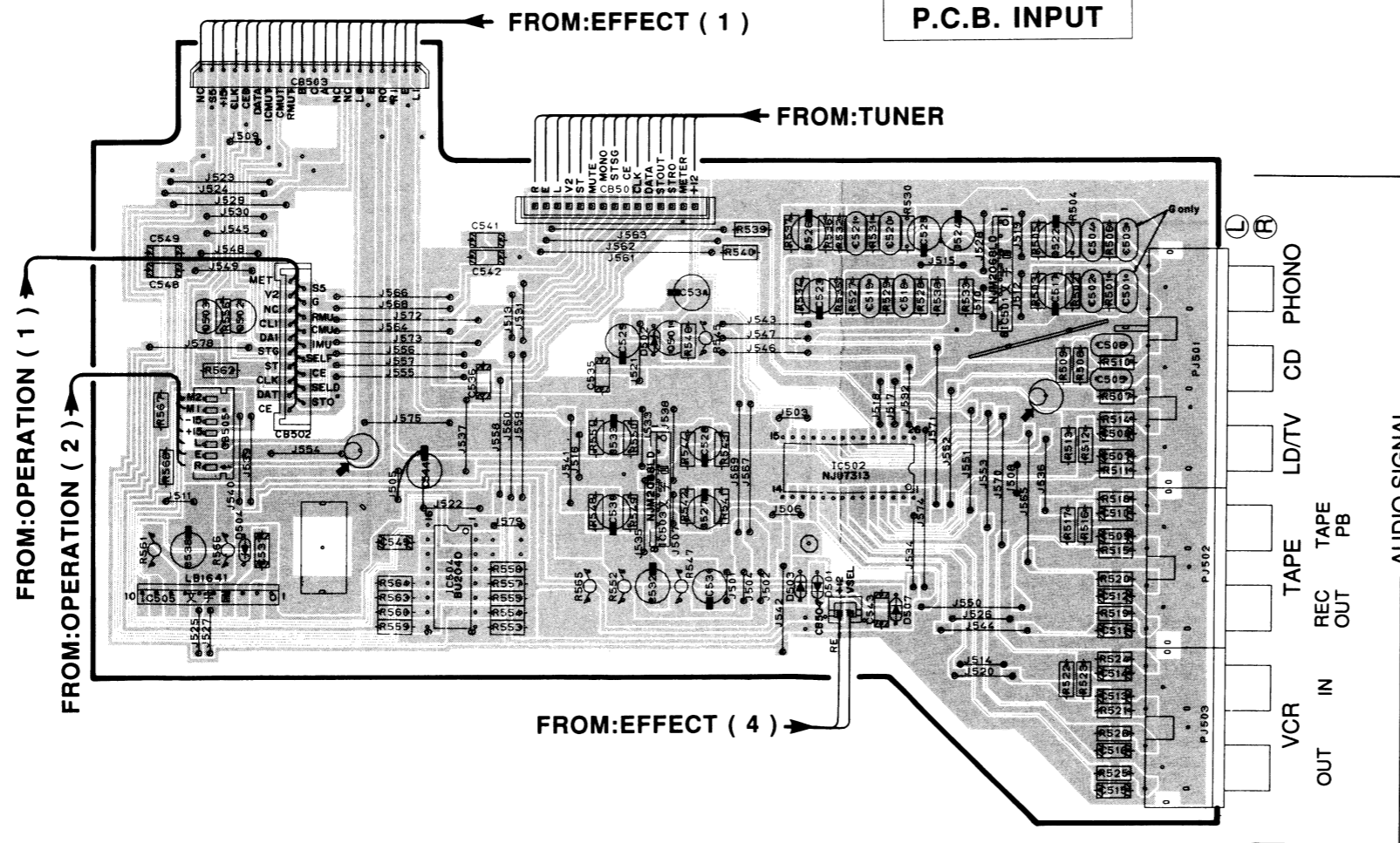

1

2

3

4

5

6

PRINTED CIRCUIT BOARD (Foil side)

② and ③ : TEST POINT WAVEFORMS (See page 31)

P.C.B. OPERATION (1)

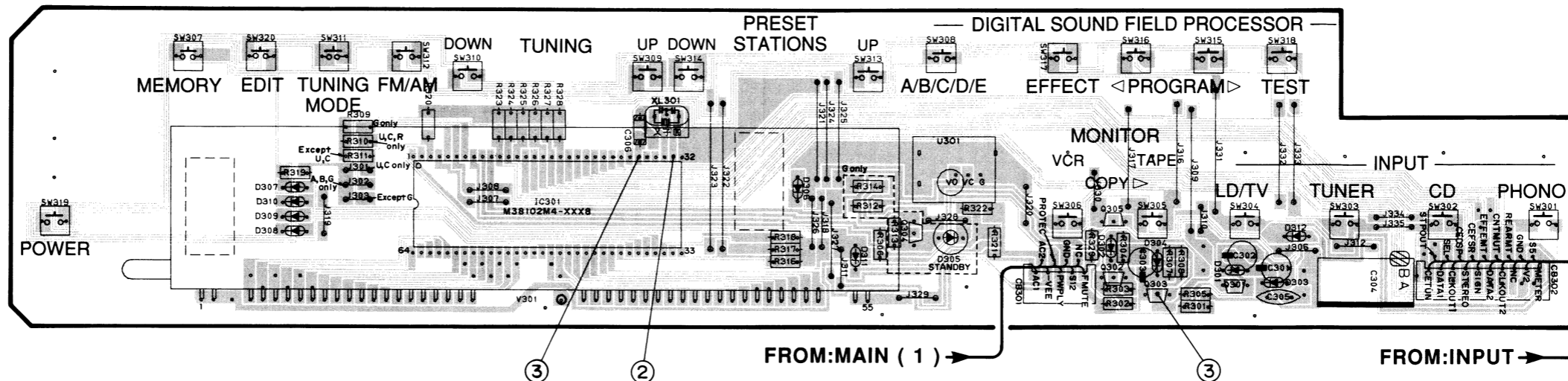

P.C.B. OPERATION (3)

P.C.B. OPERATION (2)

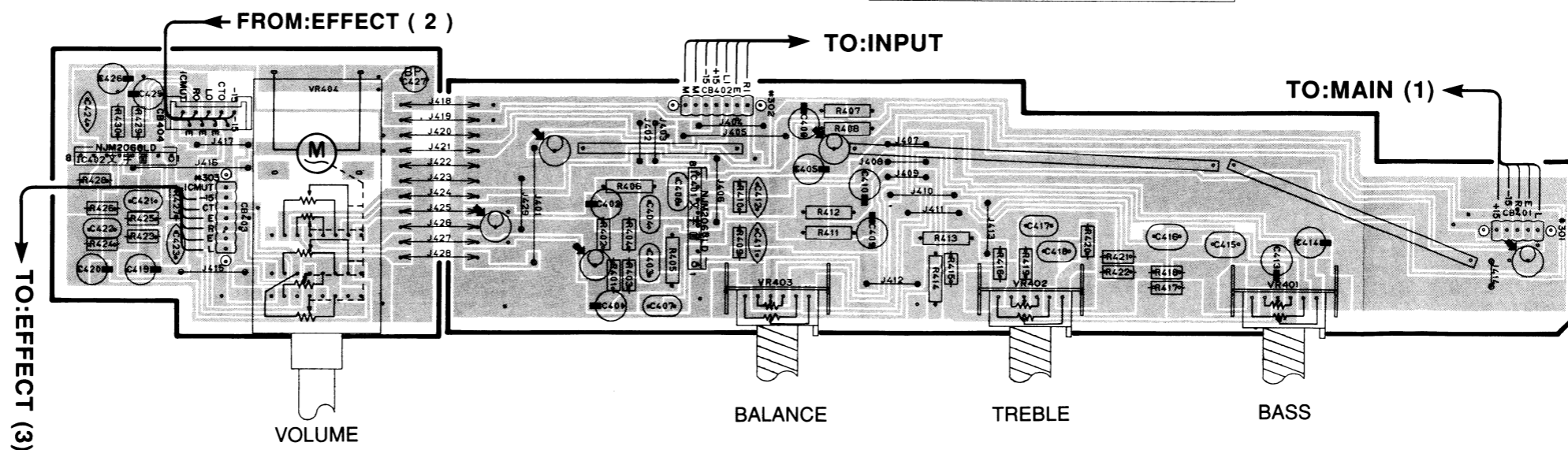

PRINTED CIRCUIT BOARD (Foil side)

● U, C, models

P.C.B. MAIN (2)

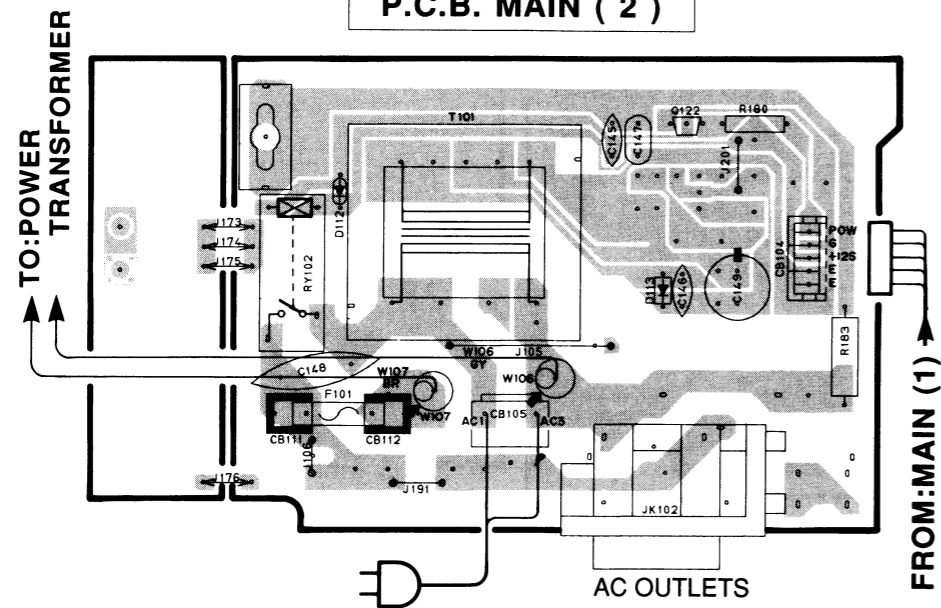

● G model

P.C.B. MAIN (2)

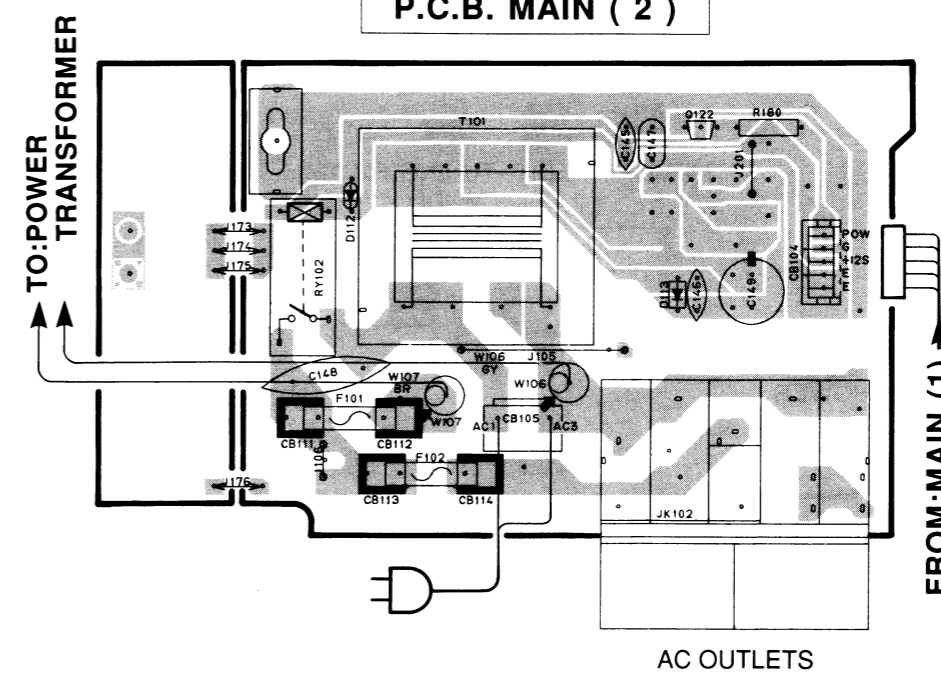

● A, B models

P.C.B. MAIN (2)

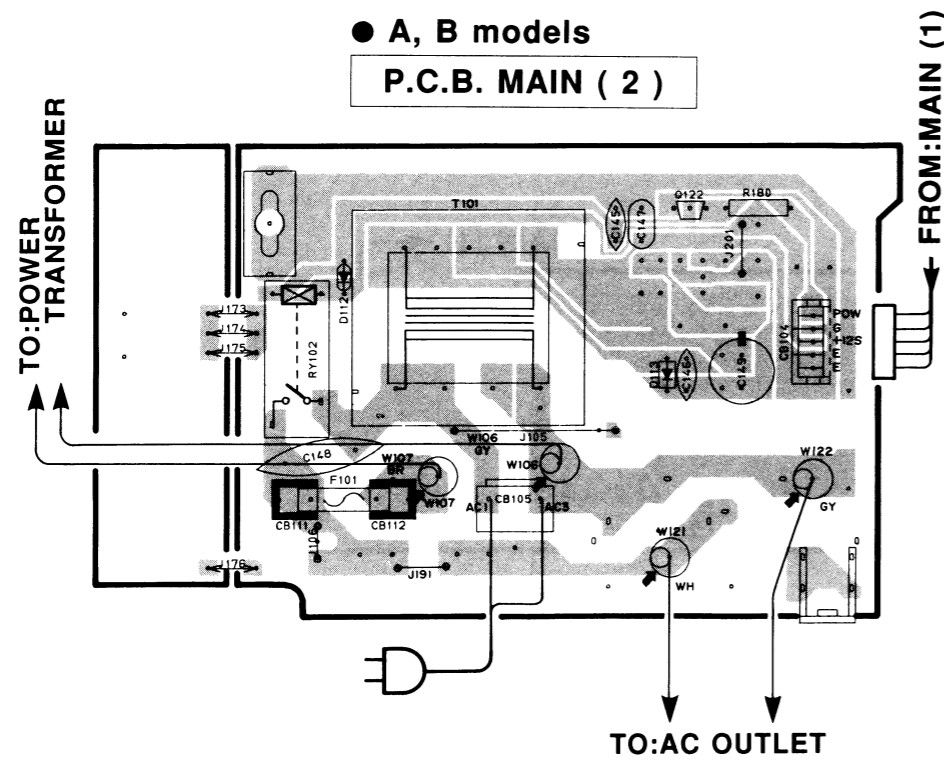

● R model

P.C.B. MAIN (2)

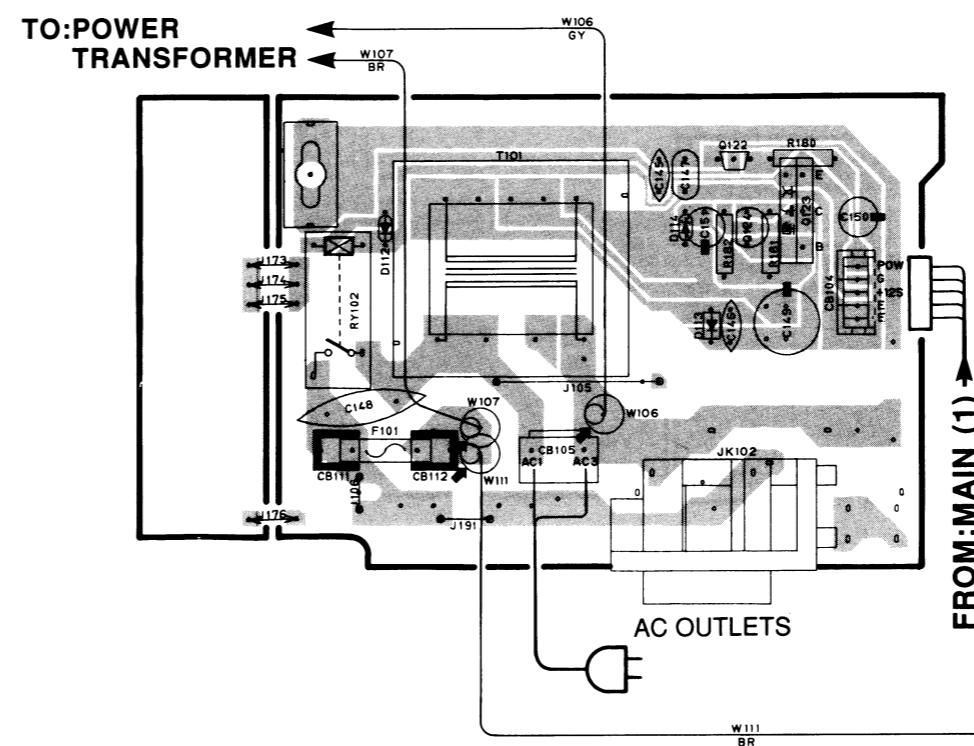

● R model

P.C.B. MAIN (4)

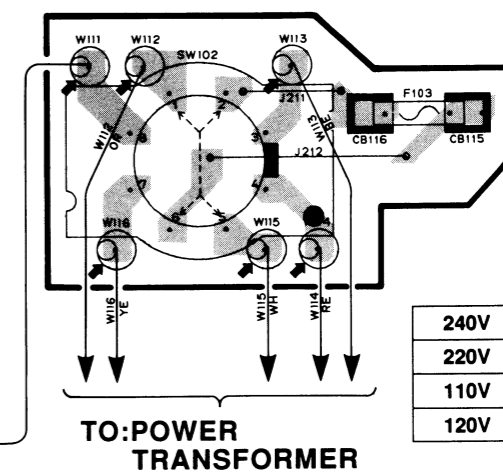

240V	1-2/5-6
220V	2-3/6-7
110V	3-4/7-8
120V	4-5/8-1

1

2

3

4

5

6

■ DISPLAY DATA (VR061700)

● V301 : 13-MT-71GK

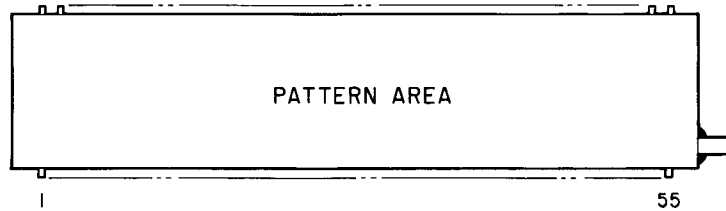

PIN CONNECTION

Pin No.	55	54	53	52	51	50	49	48	47	46	45	44	43	42	41	40	39	38	37
CONNECTION	F2	F2	NP	NP	13G	12G	11G	10G	9G	8G	7G	6G	5G	4G	3G	2G	1G	NC	NC
Pin No.	36	35	34	33	32	31	30	29	28	27	26	25	24	23	22	21	20	19	18
CONNECTION	NC	NX	NX	NX	NX	NX	NX	NX	NX	NX	NX	NX	NX	NX	NX	NX	NC	NC	NC
Pin No.	17	16	15	14	13	12	11	10	9	8	7	6	5	4	3	2	1		
CONNECTION	NC	NC	NC	NC	NC	P8	P7	P6	P5	P4	P3	P2	P1	NP	NP	F1	F1		

- Note 1) F1, F2 Filament
 2) NP No. pin
 3) NC No connection
 4) DL Datum Line
 5) 1G~13G Grid
 6) NX No extend pin

GRID ASSIGNMENT

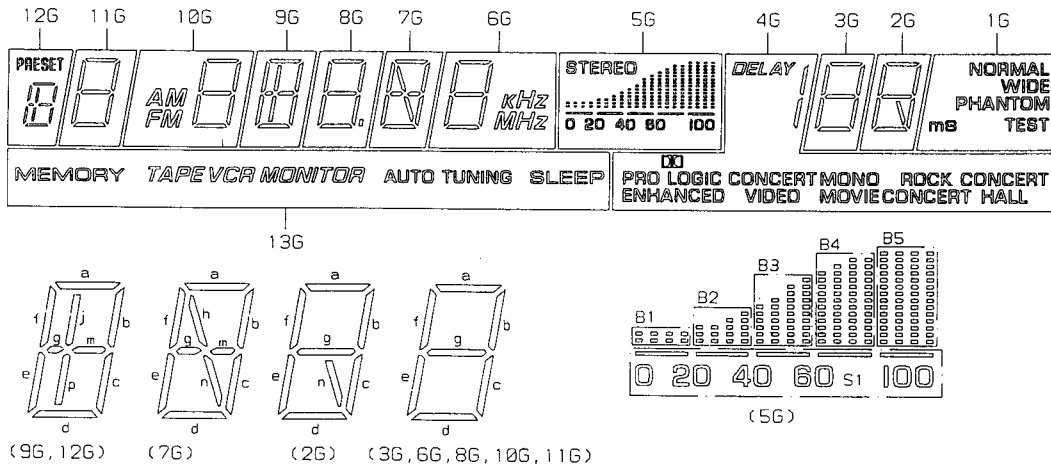

ANODE CONNECTION

	13G	12G	11G	10G	9G	8G	7G	6G	5G	4G	3G	2G	1G
P1	MEMORY	a	a	a	a	a	a	a	STEREO	DELAY	a	a	NORMAL
P2	TAPE	b, c	b	b	b	b	b	b, e	B1	/	b	b	WIDE
P3	VCR	d	c	c	c	c	c	c	B2	PRO LOGIC	c	c	PHANTOM
P4	MONITOR	e, f	d	d	d	d	d	d	B3	ENHANCED	d	d	TEST
P5	AUTO TUNING	g	e	e, f	e	e	e	f	B4	CONCERT VIDEO	e	e	ms
P6	SLEEP	m	f	g	f	f	f	g	B5	MONO MOVIE	f	f	—
P7	—	j, p	g	AM	g, m	g	g, m	kHz	S1	ROCK CONCERT	g	g	—
P8	—	PRESET	—	FM	j, p	0	h, n	MHz	—	CONCERT HALL	—	n	—

■ TEST POINT WAVEFORMS

Point ① (Pin 1 of IC2)

V : 2V/div H : 50nsec/div

DC range 1 : 1 probe

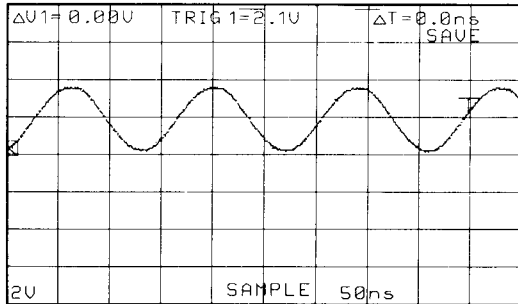

Point ② (Pin 31 of IC301)

V : 2V/div H : 0.1μsec/div

DC range 1 : 1 probe

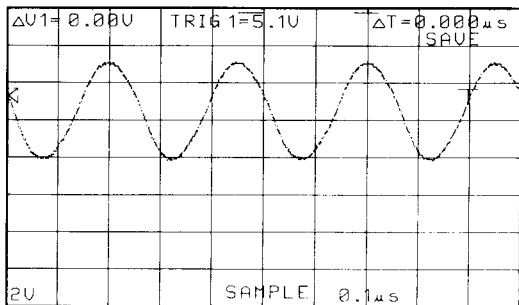

Point ③

CH 1 : Pin 27 of IC301
CH 2 : Collector of Q301

V : 2V/div (CH1) V : 5V/div (CH2)

H : 0.5sec/div

DC range 1 : 1 probe

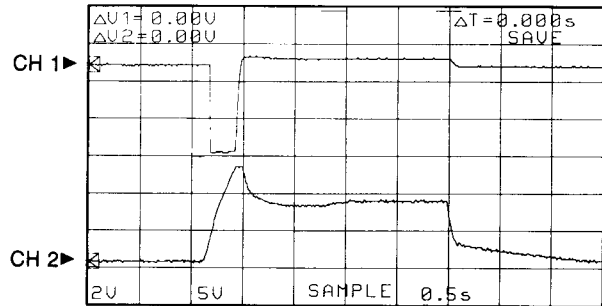

With the POWER switch turned ON, connect the power cord to the AC outlet. Disconnect the power cord from the AC outlet.

* This waveform is not available by pushing the power switch ON and OFF.

Point ④ (Pin 56 of IC703)

V : 2V/div H : 50nsec/div

DC range 1 : 1 probe

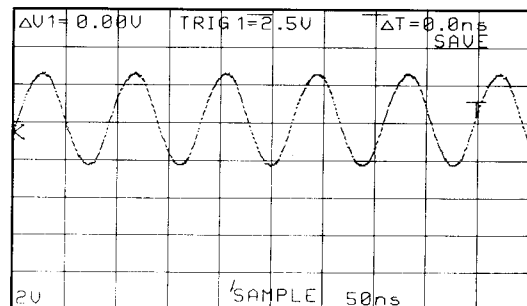

SCHEMATIC DIAGRAM (TUNER)

Each voltage given here represents that in the FM (98.1MHz, STEREO) reception mode but the one in the parentheses () is that in the AM (1080kHz, MAN'L) reception mode

CAPACITOR	
REMARKS	PARTS NAME
NO MARK	ELECTROLYTIC CAPACITOR
⊗	TANTALUM CAPACITOR
NO MARK	CERAMIC CAPACITOR
⊙	CERAMIC TUBULAR CAPACITOR
⊖	POLYESTER FILM CAPACITOR
○	POLYSTYRENE FILM CAPACITOR
⊕	MICA CAPACITOR
⊖	POLYPROPYLENE FILM CAPACITOR
⊙	SEMICONDUCTIVE CERAMIC CAPACITOR

RESISTOR	
REMARKS	PARTS NAME
NO MARK	CARBON FILM RESISTOR (P=5)
⊠	CARBON FILM RESISTOR (P=10)
△	METAL OXIDE FILM RESISTOR
⊠	METAL FILM RESISTOR
⊠	METAL PLATE RESISTOR
⊠	FIRE PROOF CARBON FILM RESISTOR
⊠	CEMENT MOLDED RESISTOR
⊠	SEMI VARIABLE RESISTOR
⊠	CHIP RESISTOR

NOTICE
 (J)..... Japanese model
 (U)..... U.S.A model
 (C)..... Canadian model
 (A)..... Australian model
 (G)..... European model
 (B)..... British model
 (R)..... General model
 (P)..... AP model

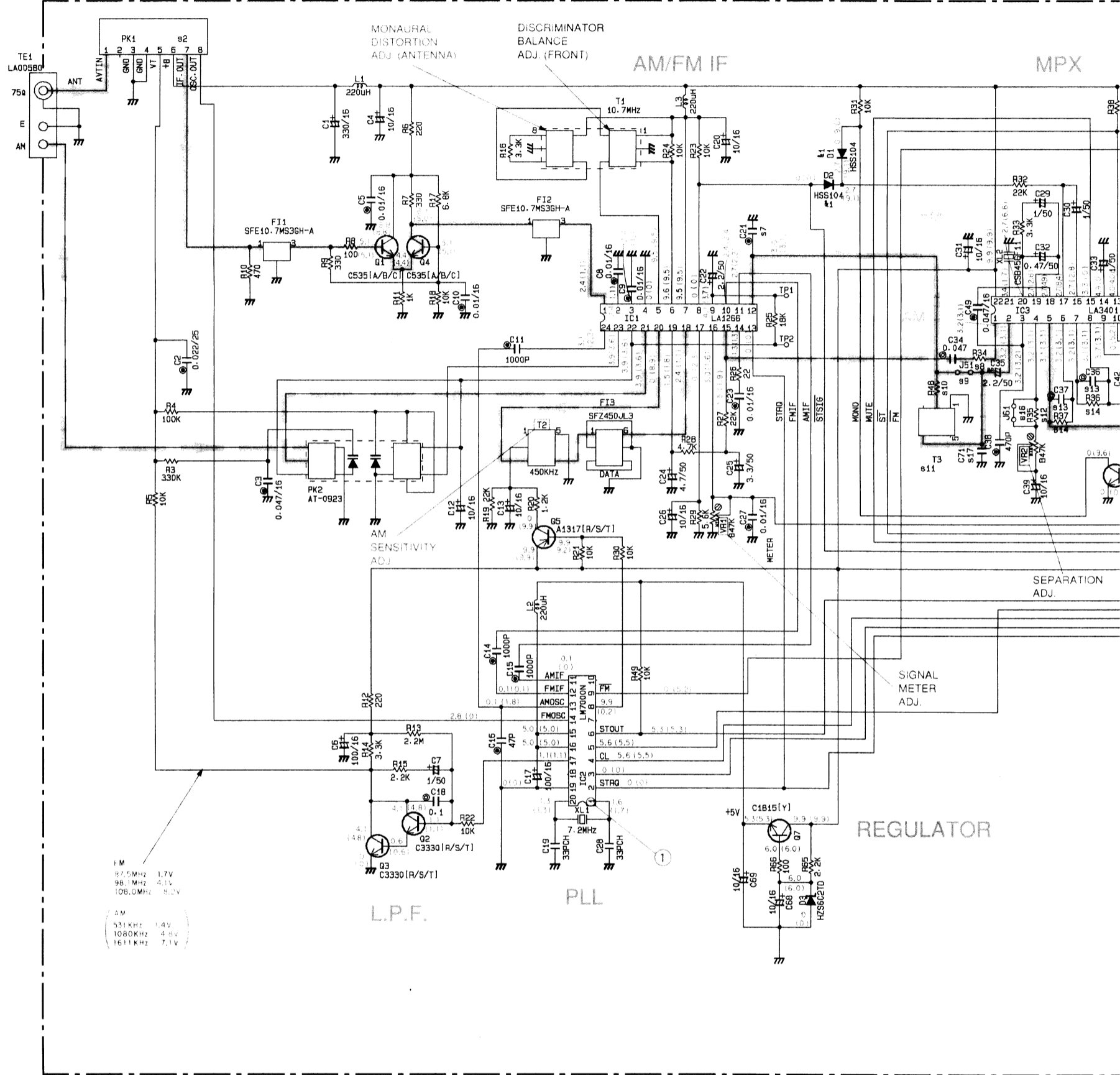

Mode	Freq	Voltage
FM	97.5MHz	1.7V
FM	98.1MHz	4.1V
FM	108.0MHz	8.2V
AM	531KHz	1.4V
AM	1080KHz	4.8V
AM	1611KHz	7.1V

● Except G model

PK1 : ENV-17298GI (VR242200)

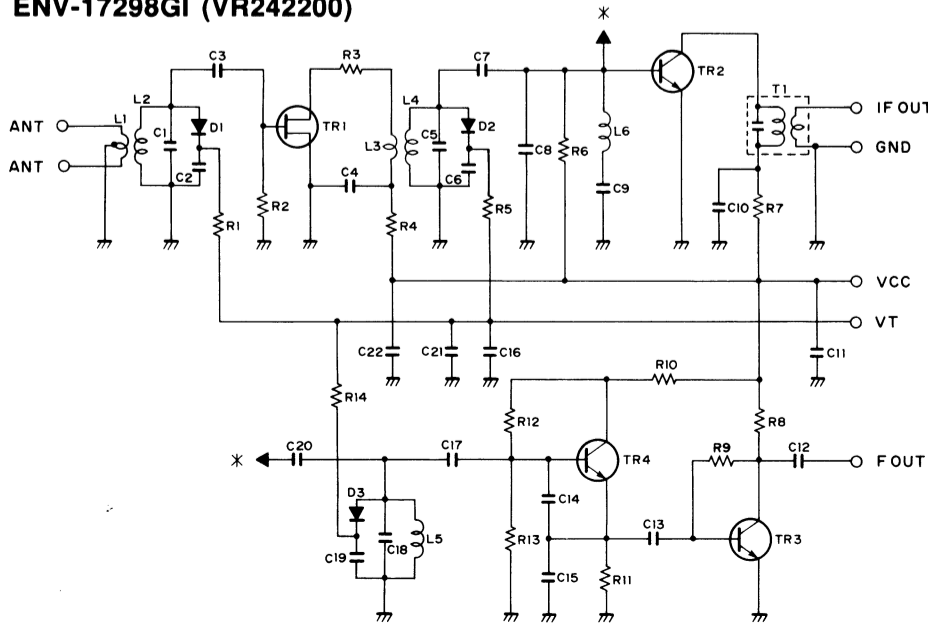

● G model only

PK1 : ENV-17297GI (VQ987600)

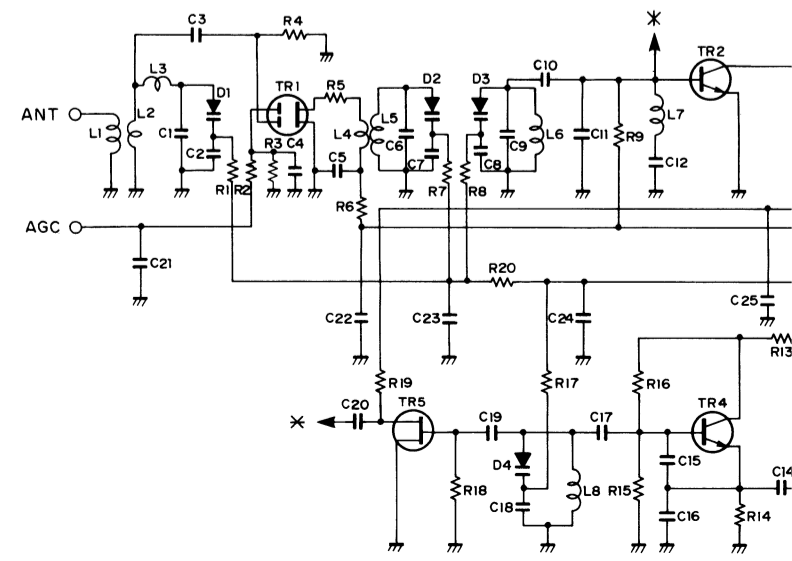

Each voltage given here represents that in the FM (98.1MHz, STEREO) reception mode but the one in the parentheses () is that in the AM (1080kHz, MAN'L) reception mode.

REMARKS	PARTS NAME
NO MARK	CARBON FILM RESISTOR (P=5)
□	CARBON FILM RESISTOR (P=10)
△	METAL OXIDE FILM RESISTOR
▲	METAL FILM RESISTOR
⊠	METAL PLATE RESISTOR
■	FIRE PROOF CARBON FILM RESISTOR
□	CEMENT MOLDED RESISTOR
⊙	SEMI VARIABLE RESISTOR
■	CHIP RESISTOR

NOTICE
 (J)..... Japanese model
 (U)..... U.S.A model
 (C)..... Canadian model
 (A)..... Australian model
 (G)..... European model
 (B)..... British model
 (R)..... General model
 (P)..... RP model

	U-C	R	A-B	G
1				
2	PK1	VR24220	VR24220	VQ98760
3				
4				
5				
6				
7	C21	100P	100P	100P X
8	R34	10K	10K	10K 27K
9	J51	○	○	○ X
10	R4B	X	X	X 4.7K
11	T3	X	X	X VQ36570
12	R35	22K	22K	22K X
13	C36-37	580P	580P	470P 390P
14	R36-37	100K	100K	100K 120K
15	SW1	X	VF54120	X X
16	J61	X	X	X ○
17	C71	X	X	X 120PCH

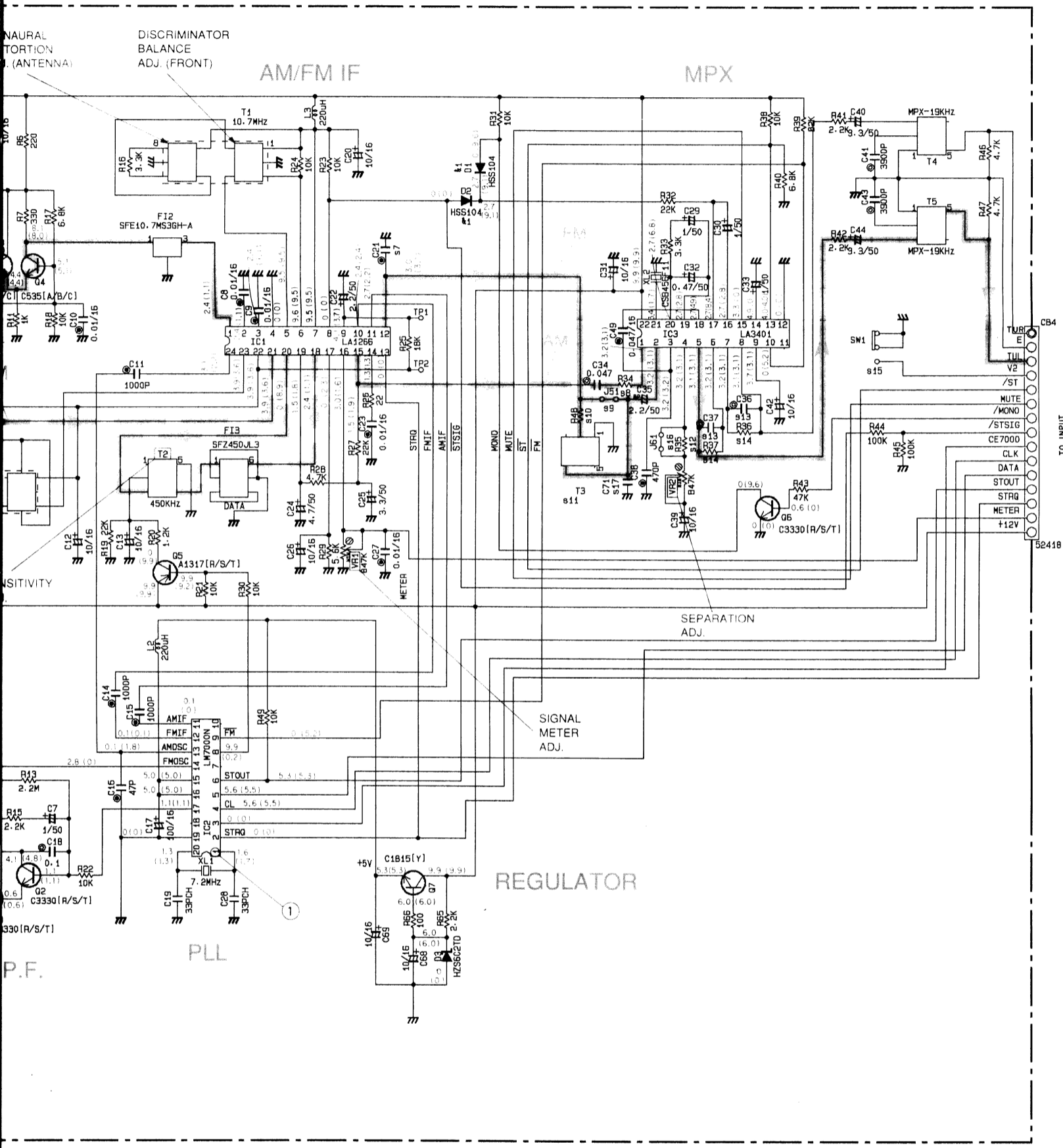

Interchangeable Parts at Manufacture-Stage

Mark	Reference Parts Number	Parts Name
#1	D1.2	HSS104 1SS133 1SS176

● G model only
 PK1 : ENV-17297GI (VQ987600)

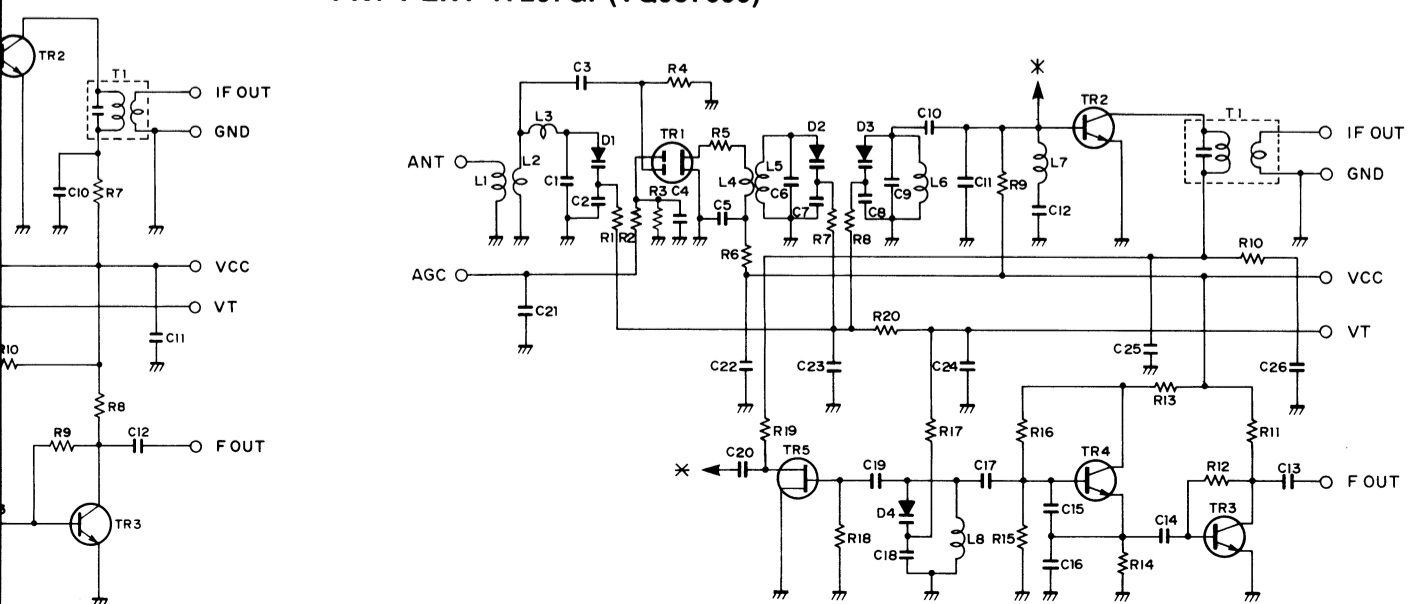

PIN CONNECTION DIAGRAM OF TRANSISTORS, DIODES AND ICs.

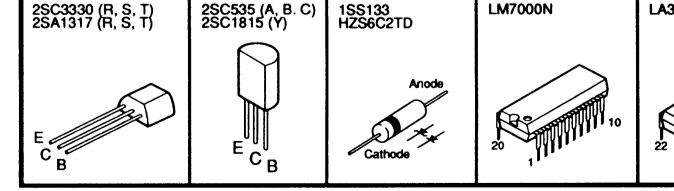

S		U. C	R	A. B	G
1					
2	PK1	VR24220	VR24220	VR24220	VQ9B760
3					
4					
5					
6					
7	C21	100P	100P	100P	X
8	R34	10K	10K	10K	27K
9	J51	○	○	○	X
10	R4B	X	X	X	4.7K
11	T3	X	X	X	VQ36570
12	R35	22K	22K	22K	X
13	C36-37	680P	680P	470P	390P
14	R36-37	100K	100K	100K	120K
15	SW1	X	VF54120	X	X
16	J61	X	X	X	○
17	C71	X	X	X	120PCH

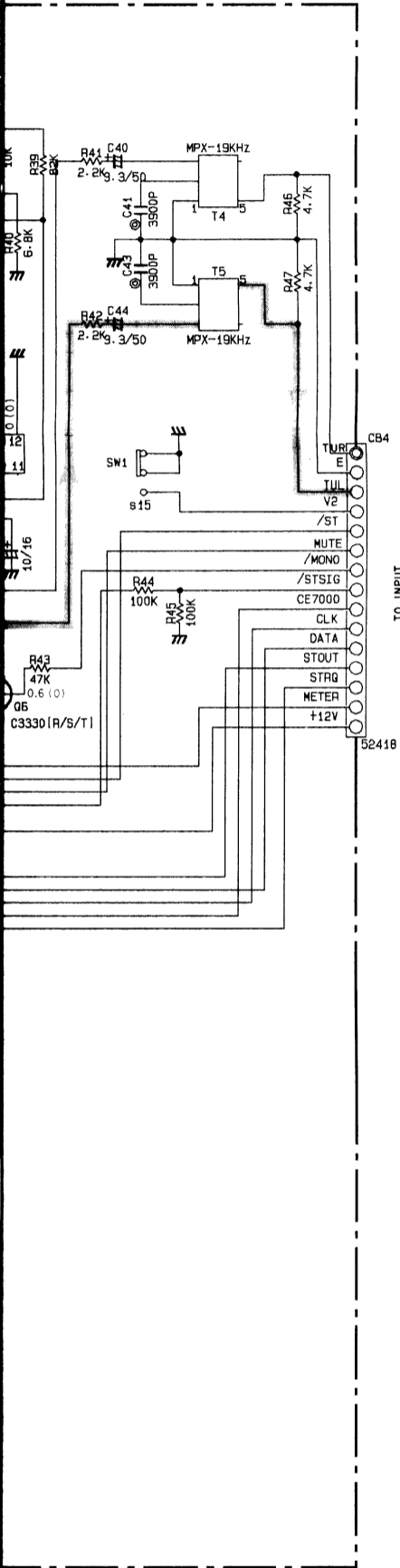

Interchangeable Parts at Manufacture-Stage

Mark	Reference Parts Number	Parts Name
#1	D1-2	HSS104 1SS133 1SS176

IC1 : LA1266
AM/FM IF

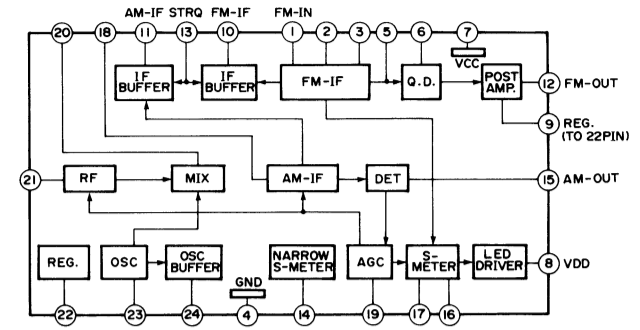

IC2 : LM7000N
PLL Controller

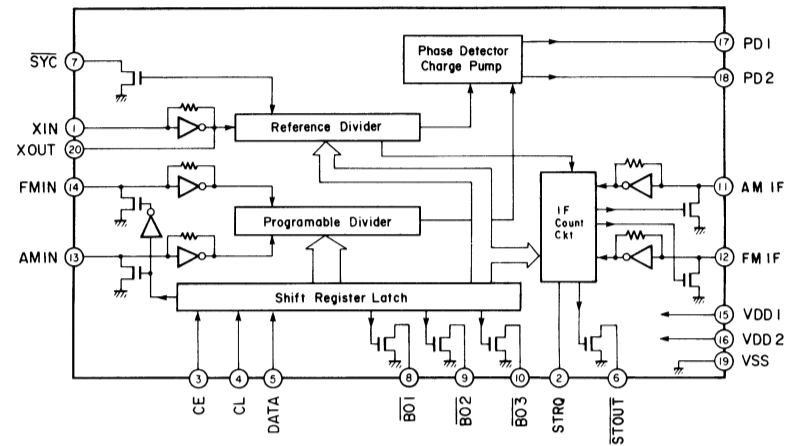

IC3 : LA3401
MPX

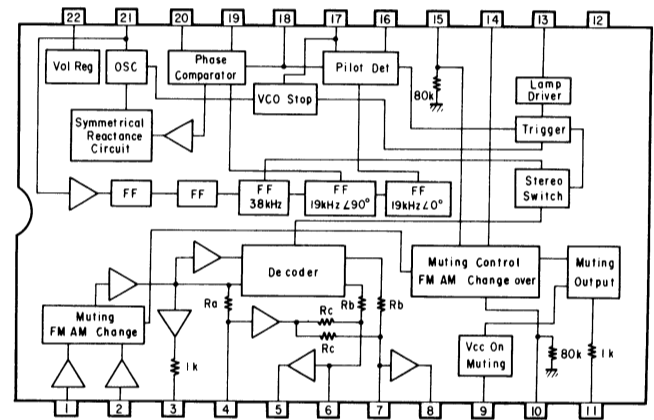

Point ① (Pin 1 of IC2)

V : 2V/div H : 50nsec/div
DC range 1 : 1 probe

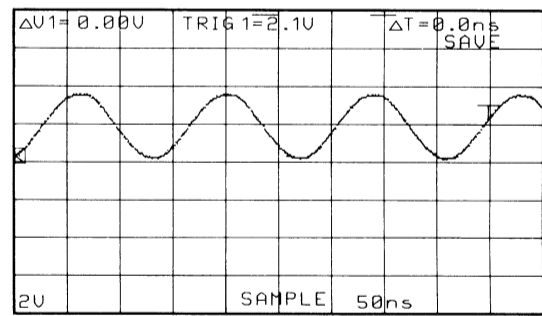

PIN CONNECTION DIAGRAM OF TRANSISTORS, DIODES AND ICs.

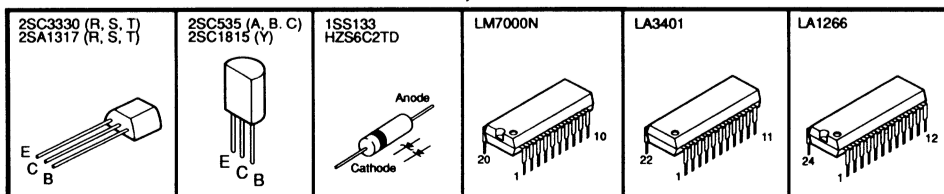

- All voltage are measured with a 10MΩ/DC electric volt meter.
- Components having special characteristics are marked Δ and must be replaced with parts having specifications equal to those originally installed.
- Schematic diagram is subject to change without notice.

SCHEMATIC DIAGRAM (INPUT)

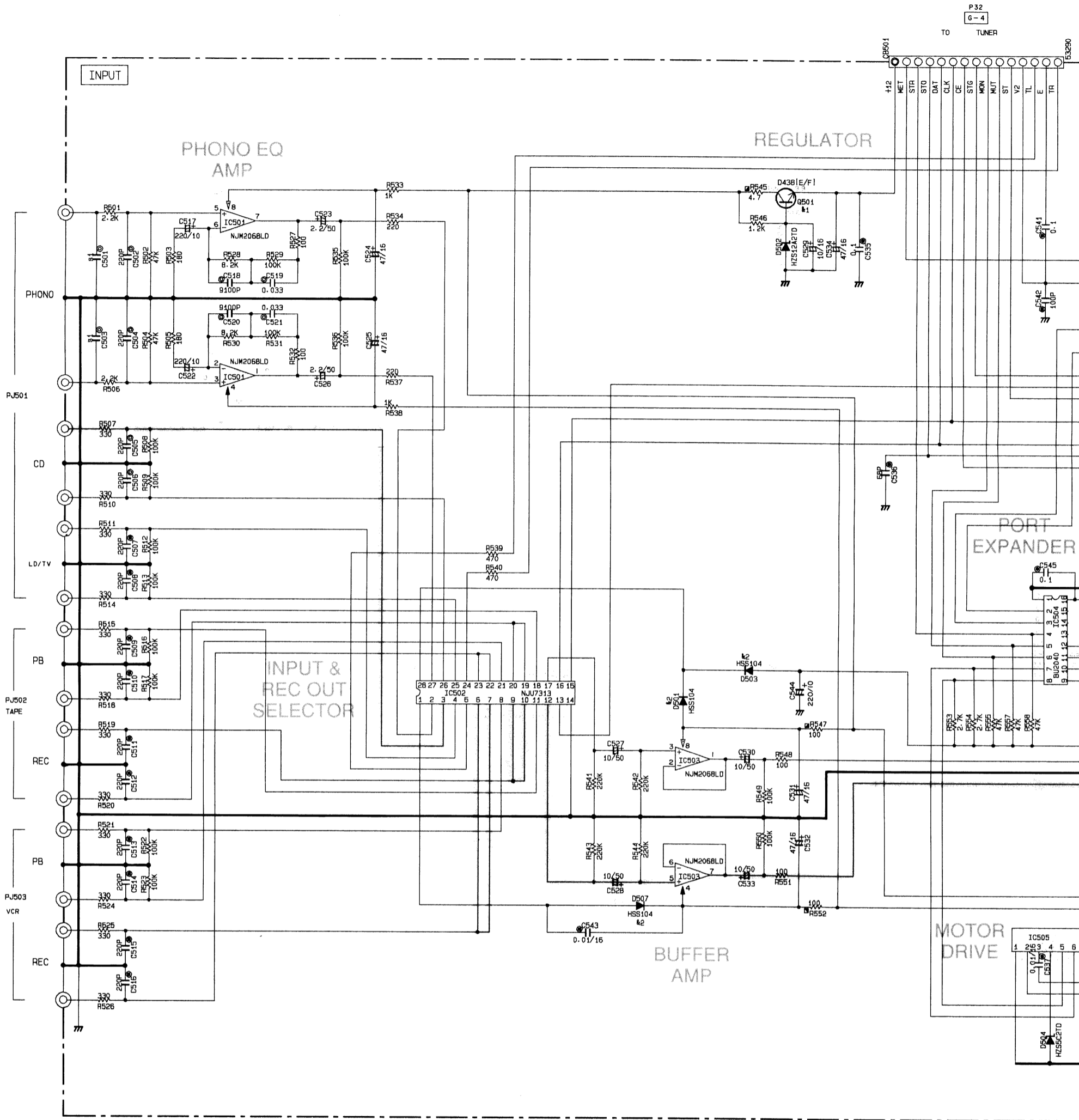

PIN CONNECTION DIAGRAM OF TRANSISTORS, DIODES AND ICs.

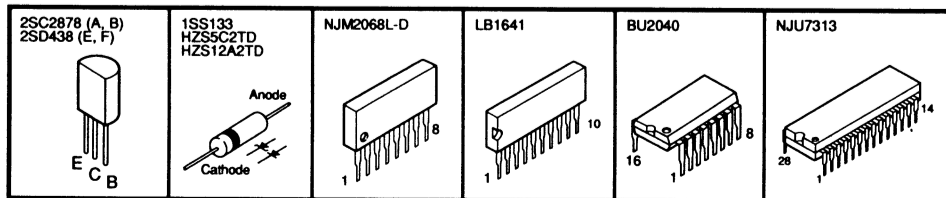

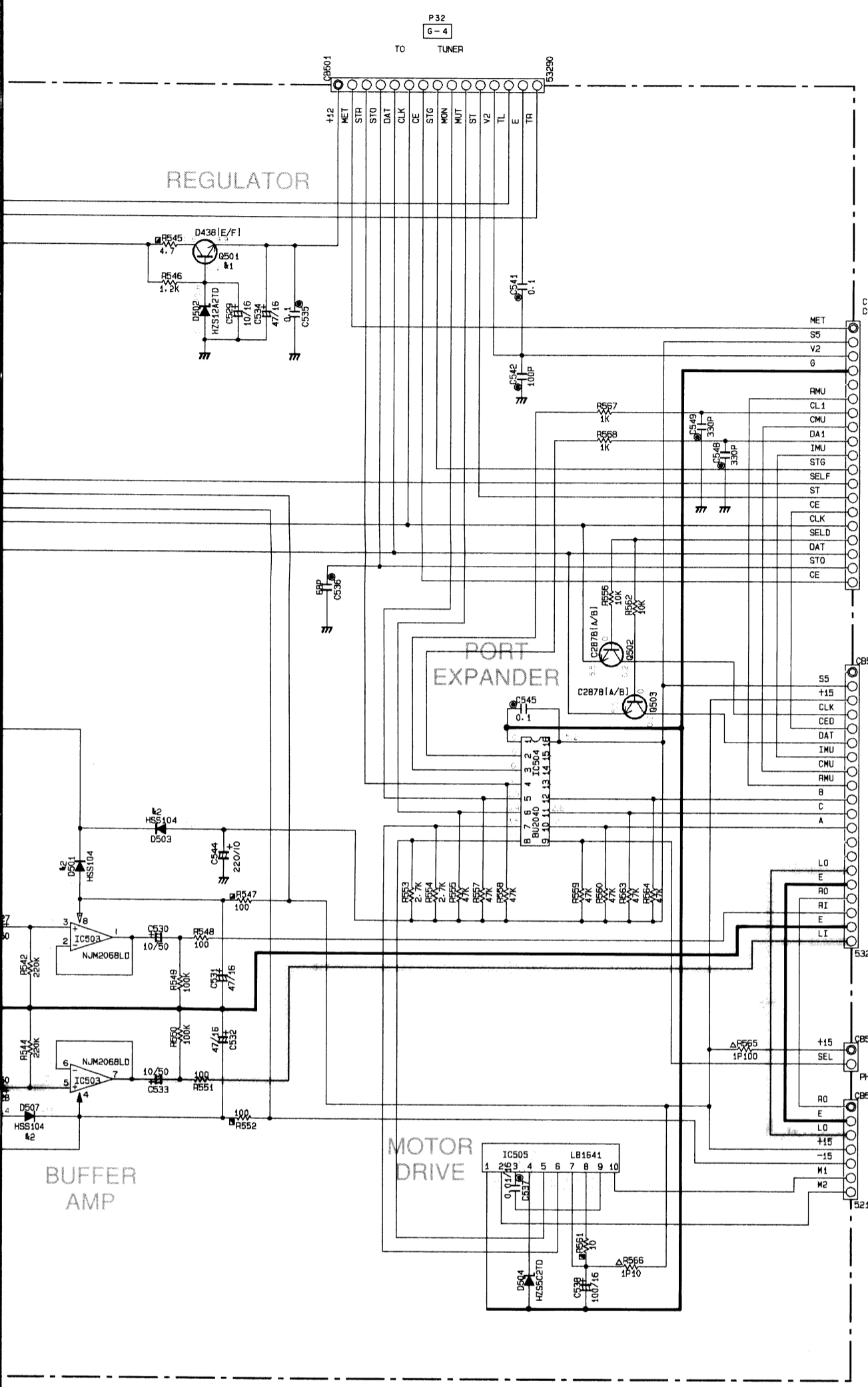

CAPACITOR

REMARKS	PARTS NAME	
NO MARK	ELECTROLYTIC CAPACITOR	#
⊗	TANTALUM CAPACITOR	
NO MARK	CERAMIC CAPACITOR	#
⊙	CERAMIC TUBULAR CAPACITOR	
⊖	POLYESTER FILM CAPACITOR	
○	POLYSTYRENE FILM CAPACITOR	
⊕	MICA CAPACITOR	
⊗	POLYPROPYLENE FILM CAPACITOR	
⊙	SEMICONDUCTIVE CERAMIC CAPACITOR	

RESISTOR

REMARKS	PARTS NAME
NO MARK	CARBON FILM RESISTOR (P=5)
⊠	CARBON FILM RESISTOR (P=10)
△	METAL OXIDE FILM RESISTOR
⊠	METAL FILM RESISTOR
⊠	METAL PLATE RESISTOR
⊠	FIRE PROOF CARBON FILM RESISTOR
⊠	CEMENT MOLDED RESISTOR
⊠	SEMI VARIABLE RESISTOR
⊠	CHIP RESISTOR

Interchangeable Parts at Manufacture-Stage

Mark	Reference	Parts Number	Parts Name
k1	D501	2S04381E/F1 2S06671C/D1	
k2	D501, 503, 507	HSS104 1SS133 1SS176	

	U-C-R-A-B	G
s1	C501, 503	X
		220P

TO OPERATION(1)
P34
A-6

TO EFFECT(1)
P36
I-4

TO EFFECT(4)
P36
A-8

TO OPERATION(2)
P34
D-1

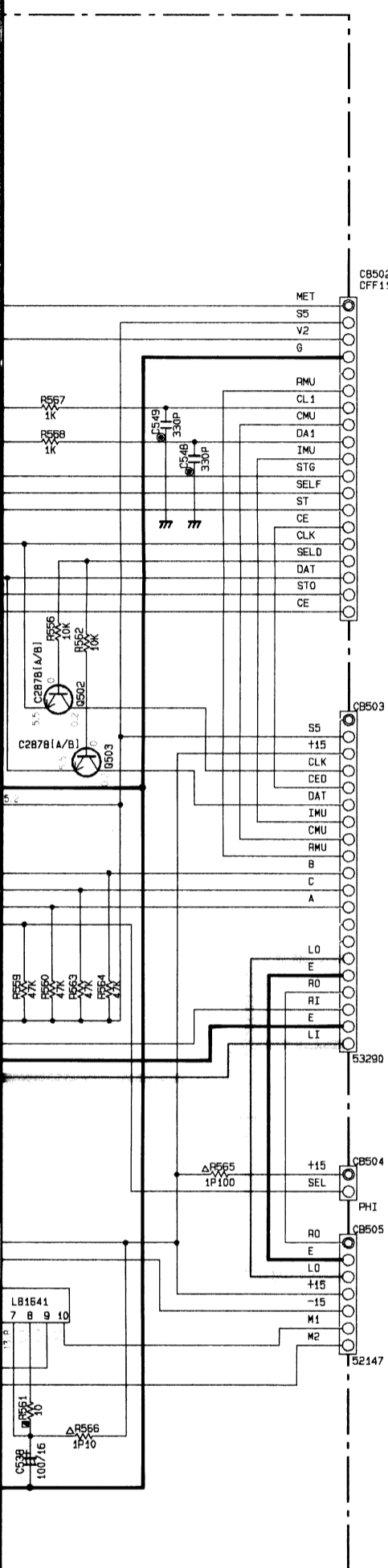

CAPACITOR

REMARKS	PARTS NAME	
NO MARK	ELECTROLYTIC CAPACITOR	#
⊗	TANTALUM CAPACITOR	#
NO MARK	CERAMIC CAPACITOR	#
⊙	CERAMIC TUBULAR CAPACITOR	#
⊖	POLYESTER FILM CAPACITOR	#
○	POLYSTYRENE FILM CAPACITOR	#
⊕	MICA CAPACITOR	#
⊖	POLYPROPYLENE FILM CAPACITOR	#
⊖	SEMICONDUCTIVE CERAMIC CAPACITOR	#

RESISTOR

REMARKS	PARTS NAME	
NO MARK	CARBON FILM RESISTOR [P=5]	
⊗	CARBON FILM RESISTOR [P=10]	
△	METAL OXIDE FILM RESISTOR	
⊖	METAL FILM RESISTOR	
⊗	METAL PLATE RESISTOR	
⊖	FIRE PROOF CARBON FILM RESISTOR	
⊖	CEMENT MOLDED RESISTOR	
⊖	SEMI VARIABLE RESISTOR	
⊖	CHIP RESISTOR	

TO OPERATION(1)
P34
A-6

Interchangeable Parts at Manufacture-Stage

Mark	Reference Parts Number	Parts Name
k1	Q501	2SD4381E/F1 2SD6671C/D1
k2	D501, 503, 507	H88104 1SS133 1SS176

TO EFFECT(1)
P36
I-4

TO EFFECT(4)
P36
A-8

TO OPERATION(2)
P34
D-1

	U. C. R. A. B	G
81	X	220P

IC501, 503 : NJM2068L-D
Dual OP-Amp

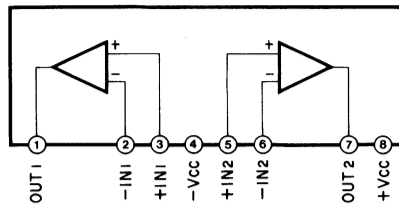

IC505 : LB1641
Motor Driver

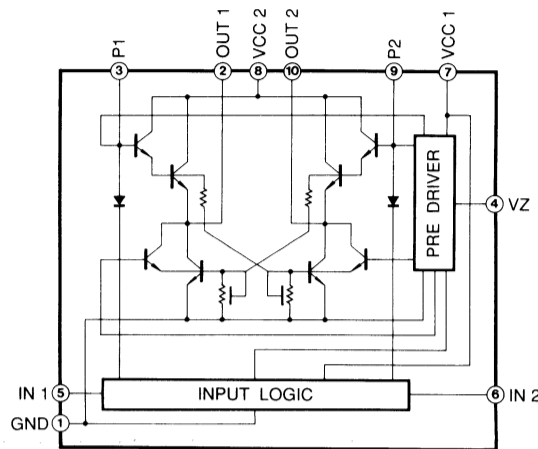

IC502 : NJU7313
Analog Function Switch

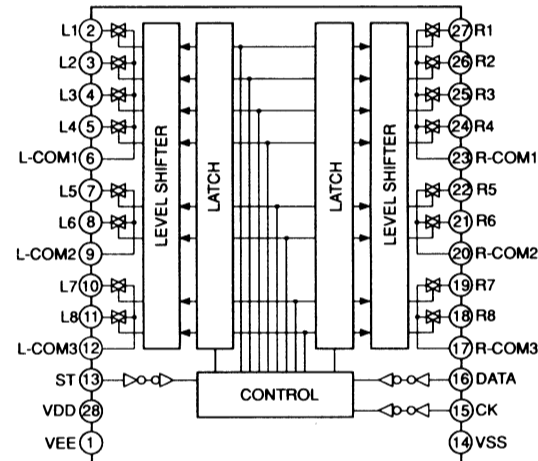

IC504 : BU2040
Port Expander

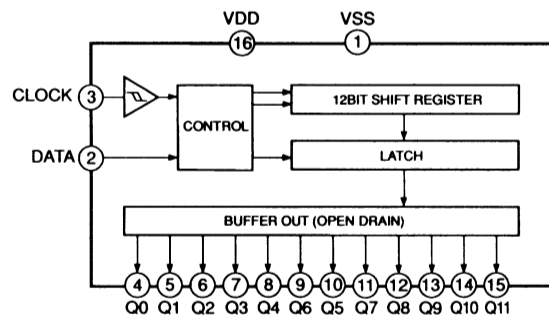

* All voltage are measured with a 10MΩ/DC electric volt meter.
 * Components having special characteristics are marked △ and must be replaced with parts having specifications equal to those originally installed.
 * Schematic diagram is subject to change without notice.

SCHEMATIC DIAGRAM (OPERATION)

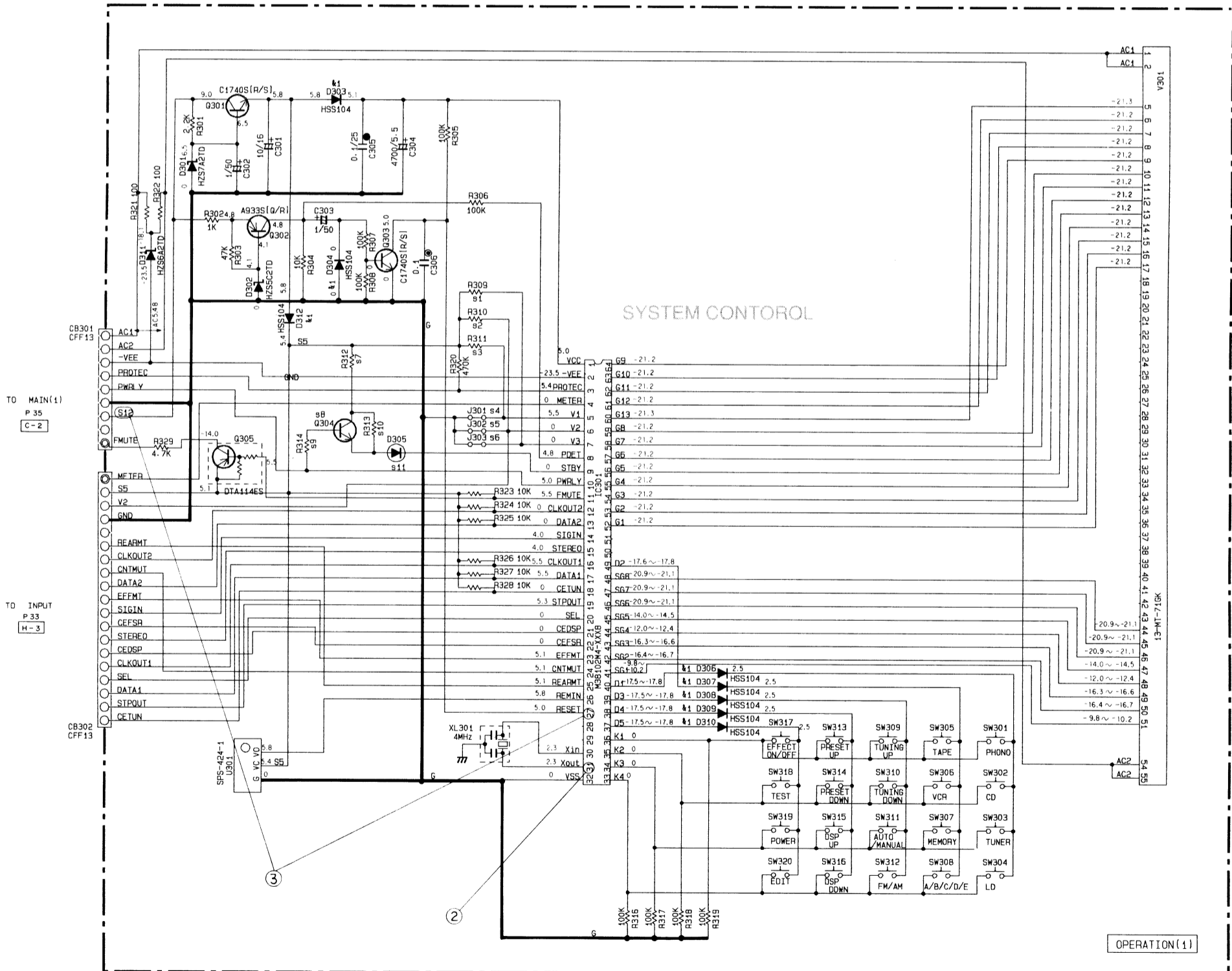
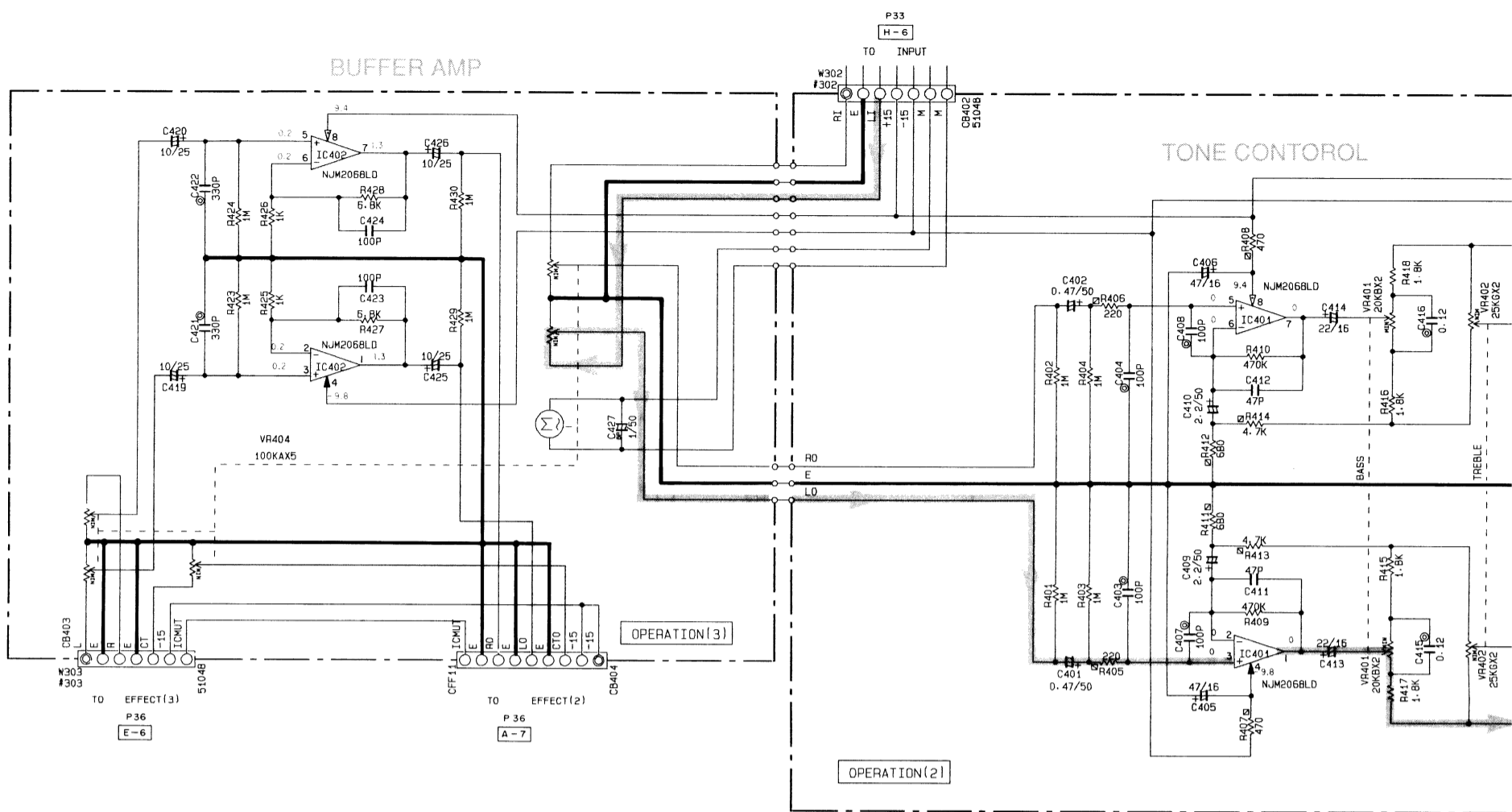

PIN CONNECTION DIAGRAM OF TRANSISTORS, DIODES AND ICs.

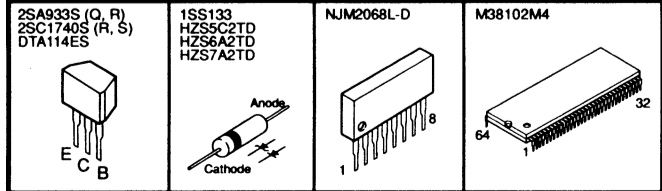

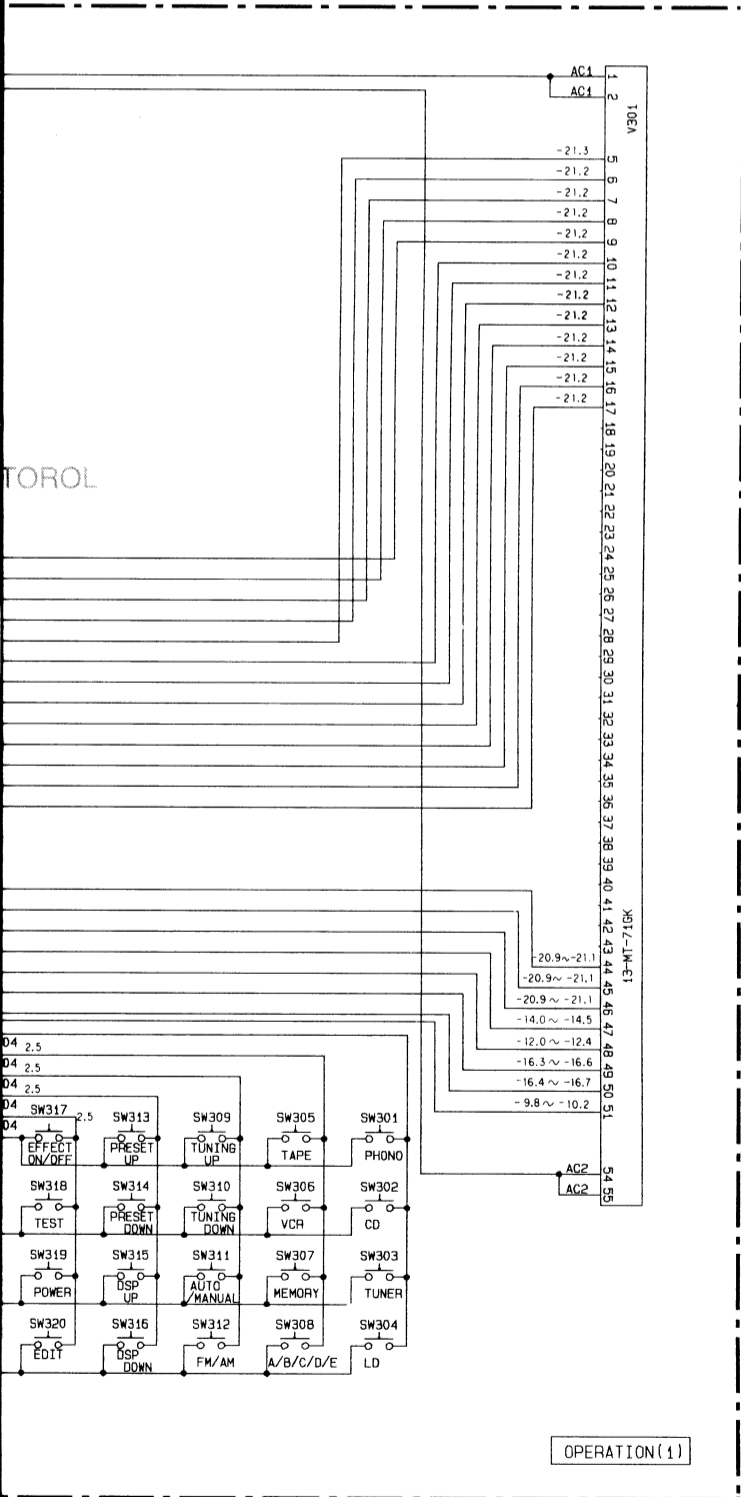
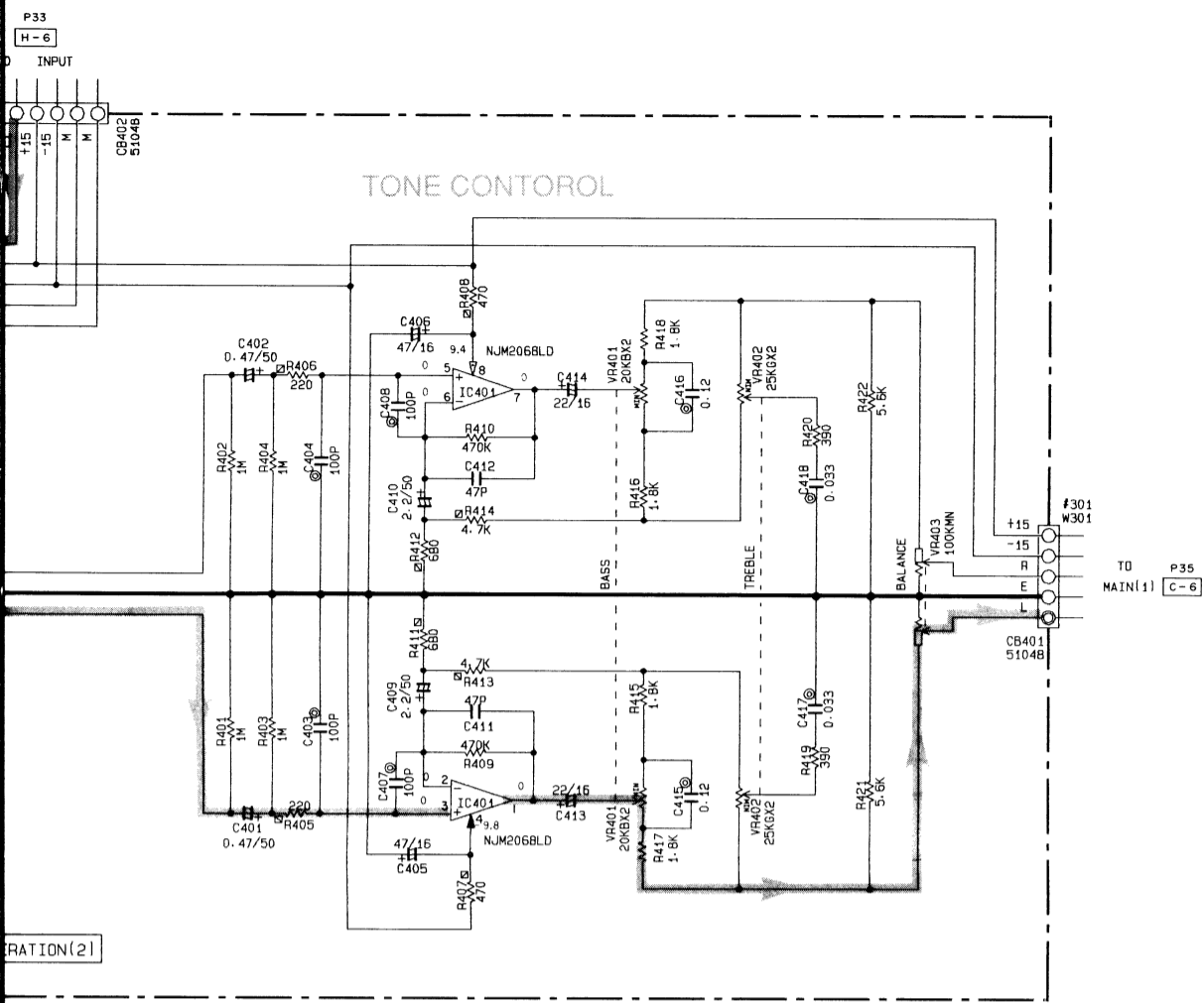

		UC	R	AB	G
s1	R309	X	X	X	100K
s2	R310	100K	100K	X	X
s3	R311	X	100K	100K	100K
s4	J301	○	X	X	X
s5	J302	X	X	○	○
s6	J303	○	○	○	X
s7	R312	X	X	X	270
s8	Q304	X	X	X	C1740(R/S)
s9	R314	X	X	X	10K
s10	R313	X	X	X	330
s11	D305	X	X	X	SLR-305VCA47 VP59400

Interchangeable Parts at Manufacture-Stage

Mark	Reference Parts Number	Parts Name
41	D303-304-306-310-312	HSS104 ISS133 ISS176

RESISTOR

REMARKS	PARTS NAME
NO MARK	CARBON FILM RESISTOR (P=5)
☑	CARBON FILM RESISTOR (P=10)
△	METAL OXIDE FILM RESISTOR
▲	METAL FILM RESISTOR
⊗	METAL PLATE RESISTOR
⊞	FIRE PROOF CARBON FILM RESISTOR
□	CEMENT MOLDED RESISTOR
⊕	SEMI VARIABLE RESISTOR
■	CHIP RESISTOR

CAPACITOR

REMARKS	PARTS NAME
NO MARK	ELECTROLYTIC CAPACITOR
⊗	TANTALUM CAPACITOR
NO MARK	CERAMIC CAPACITOR
⊙	CERAMIC TUBULAR CAPACITOR
○	POLYESTER FILM CAPACITOR
○	POLYSTYRENE FILM CAPACITOR
⊖	MICA CAPACITOR
⊕	POLYPROPYLENE FILM CAPACITOR
●	SEMICONDUCTIVE CERAMIC CAPACITOR

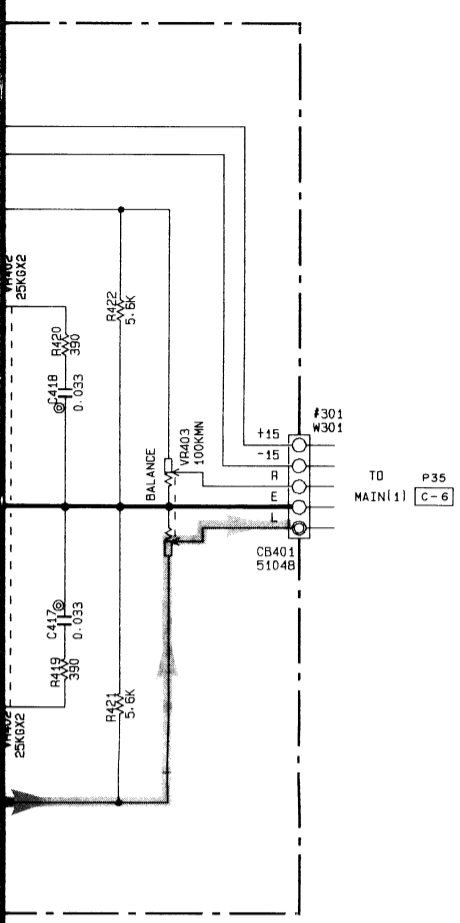

IC401, 402 : NJM2068-D
Dual OP-Amp

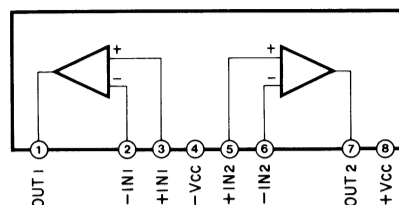

Other IC

● IC301 : M38102M4 → See page 13

Point ② (Pin 31 of IC301)

V : 2V/div H : 0.1μsec/div
DC range 1 : 1 probe

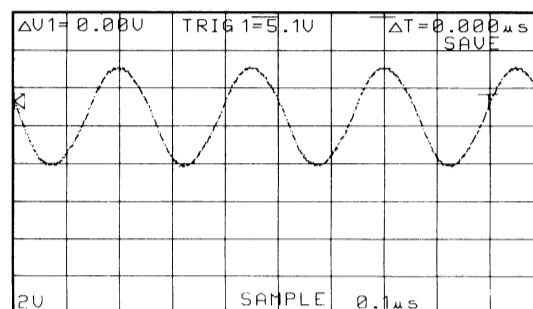

Point ③

[CH 1 : Pin 27 of IC301
CH 2 : Collector of Q301]

V : 2V/div (CH1) V : 5V/div (CH2)
H : 0.5sec/div
DC range 1 : 1 probe

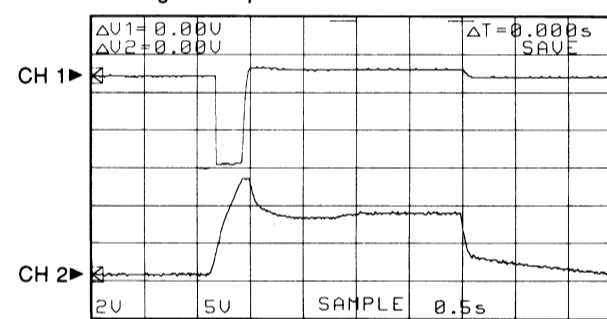

With the POWER switch turned ON, connect the power cord to the AC outlet.
Disconnect the power cord from the AC outlet.

* This waveform is not available by pushing the power switch ON and OFF.

		UC	R	AB	G
s1	R309	X	X	X	100K
s2	R310	100K	100K	X	X
s3	R311	X	100K	100K	100K
s4	J301	○	X	X	X
s5	J302	X	X	○	○
s6	J303	○	○	○	X
s7	R312	X	X	X	270
s8	Q304	X	X	X	C1740[R/S]
s9	R314	X	X	X	10K
s10	R313	X	X	X	330
s11	D305	X	X	X	SLR-305VCA47 VP59400

Interchangeable Parts at Manufacture-Stage

Mark	Reference Parts Number	Parts Name
△	D303-304-306-310-312	HSS104 1SS133 1SS176

RESISTOR

REMARKS	PARTS NAME
NO MARK	CARBON FILM RESISTOR (P=5)
□	CARBON FILM RESISTOR (P=10)
△	METAL OXIDE FILM RESISTOR
▲	METAL FILM RESISTOR
⊠	METAL PLATE RESISTOR
■	FIRE PROOF CARBON FILM RESISTOR
□	CEMENT MOLDED RESISTOR
⊗	SEMI VARIABLE RESISTOR
■	CHIP RESISTOR

CAPACITOR

REMARKS	PARTS NAME	
NO MARK	ELECTROLYTIC CAPACITOR	⊥
⊗	TANTALUM CAPACITOR	
NO MARK	CERAMIC CAPACITOR	
●	CERAMIC TUBULAR CAPACITOR	
⊙	POLYESTER FILM CAPACITOR	
○	POLYSTYRENE FILM CAPACITOR	
⊖	MICA CAPACITOR	
⊕	POLYPROPYLENE FILM CAPACITOR	
●	SEMICONDUCTIVE CERAMIC CAPACITOR	

* All voltage are measured with a 10MΩ/DC electric volt meter.
* Components having special characteristics are marked △ and must be replaced with parts having specifications equal to those originally installed.
* Schematic diagram is subject to change without notice.

SCHEMATIC DIAGRAM (MAIN)

Each voltage indicated here is the value obtained from RX-V480 (R model AC120V).
The value in the parentheses () is however, the voltage from R-V98 (U model).

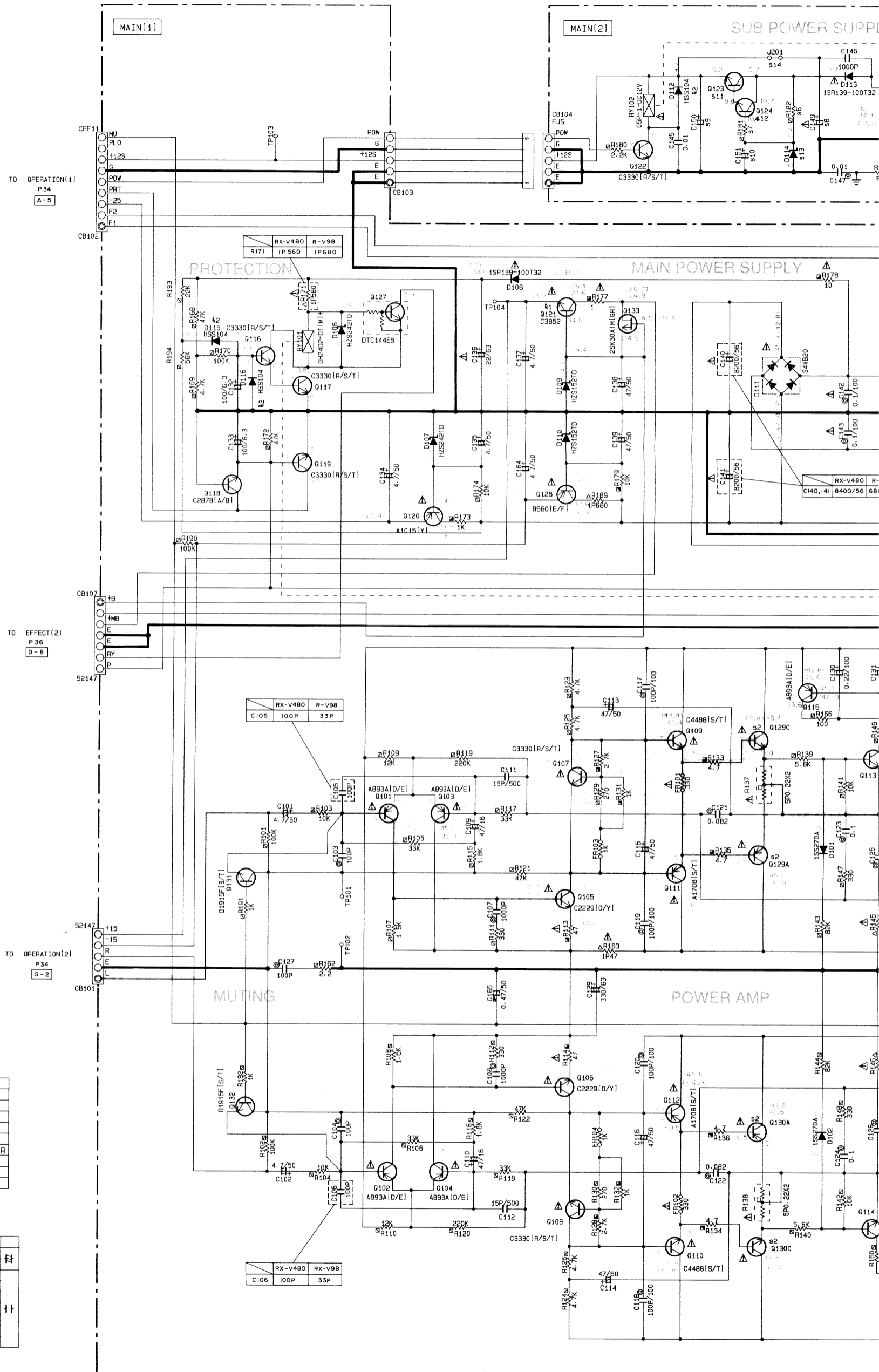

REMARKS	PARTS NAME
NO MARK	CARBON FILM RESISTOR (P=5)
□	CARBON FILM RESISTOR (P=10)
△	METAL OXIDE FILM RESISTOR
⊠	METAL FILM RESISTOR
⊞	METAL PLATE RESISTOR
■	FIRE PROOF CARBON FILM RESISTOR
□	CEMENT MOLDED RESISTOR
⊞	SEMI VARIABLE RESISTOR
■	CHIP RESISTOR

REMARKS	PARTS NAME
NO MARK	ELECTROLYTIC CAPACITOR
⊗	TANTALUM CAPACITOR
NO MARK	CERAMIC CAPACITOR
⊙	CERAMIC TUBULAR CAPACITOR
⊖	POLYESTER FILM CAPACITOR
○	POLYSTYRENE FILM CAPACITOR
⊕	MICA CAPACITOR
⊖	POLYPROPYLENE FILM CAPACITOR
●	SEMICONDUCTIVE CERAMIC CAPACITOR

PIN CONNECTION DIAGRAM OF TRANSISTORS, DIODES AND ICs.

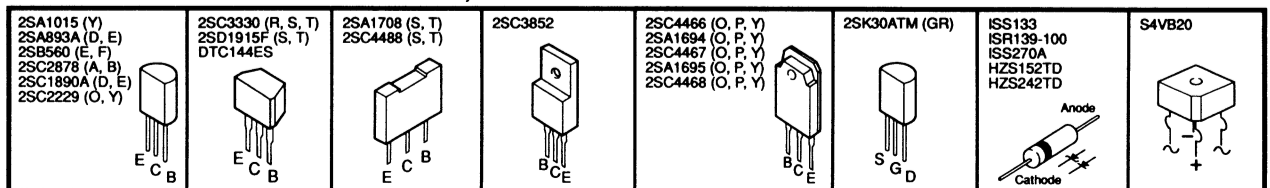

is the value obtained from RX-V480 (R model AC120V).
 is however, the voltage from R-V98 (U model).

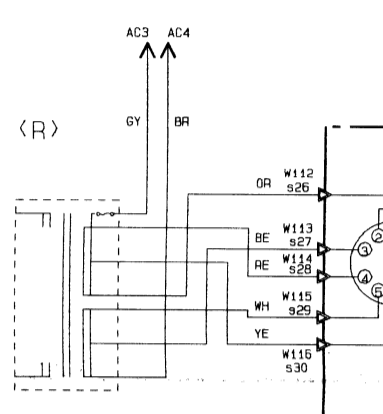
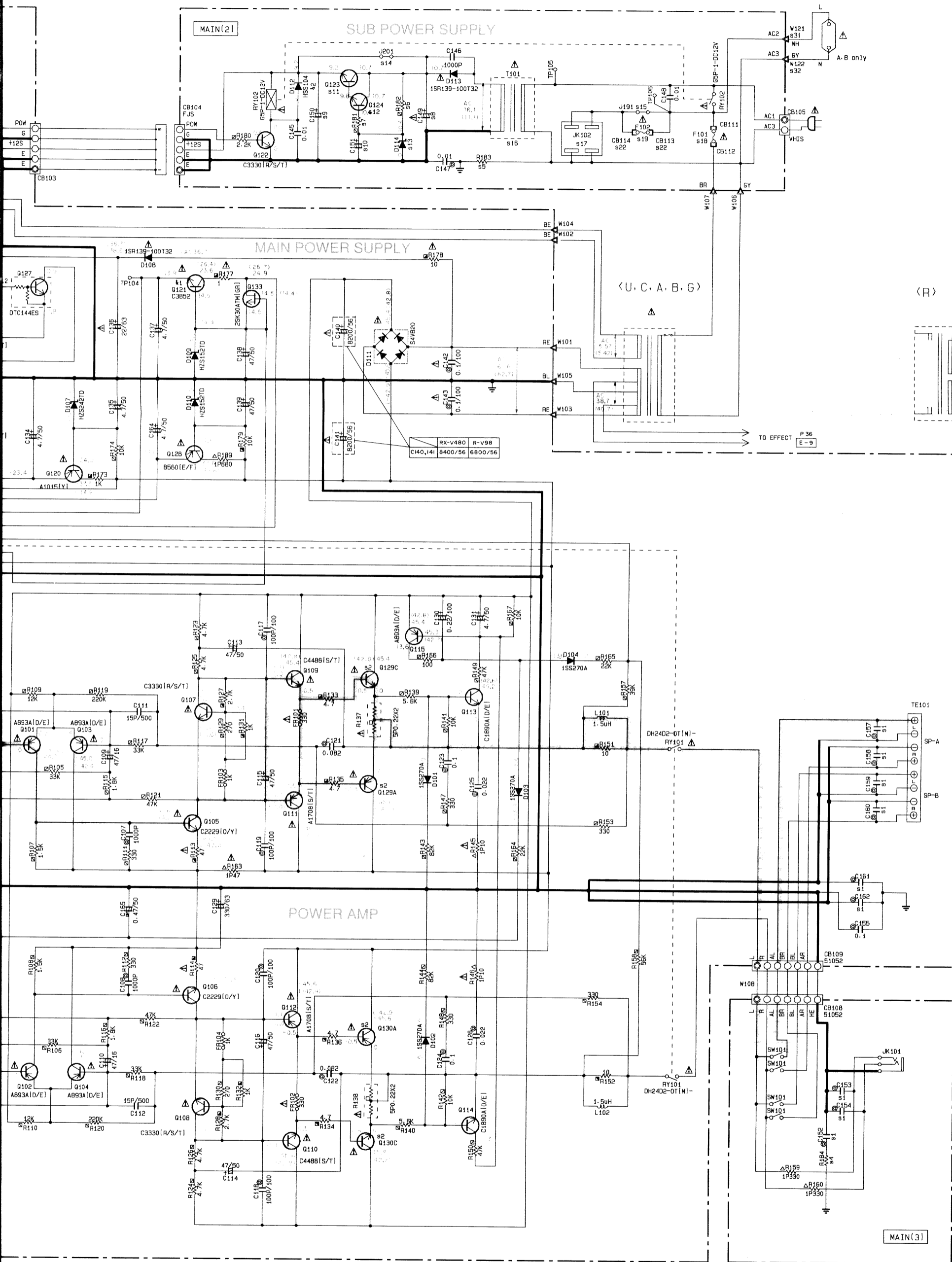

Part No.	Description	Quantity	Notes
S1	C152-154, 157-162	X	U
S2	Q129, 130	X	A1695(O/V), C446B(O/V)
S4	R184	X	
S5	R183	X	1/2P2-2M
S6	R182	X	
S7	R181	X	
S8	C149	X	330/25
S9	C150	X	
S10	C151	X	
S11	Q123	X	
S12	Q124	X	
S13	D114	X	
S14	J201	0	
S15	J191	0	
S16	T101	X	XC083
S17	JK102	X	VK48060
S18	F101	X	5.0A125V
S19	F102	X	
S20	F103	X	
S21	SW102	X	
S22	CB113-114	X	
S23	CB115-116	X	
S24			
S25	W111	X	
S26	W112	X	
S27	W113	X	
S28	W114	X	
S29	W115	X	
S30	W116	X	
S31	W121	X	
S32	W122	X	

TRANSISTORS, DIODES AND ICs.

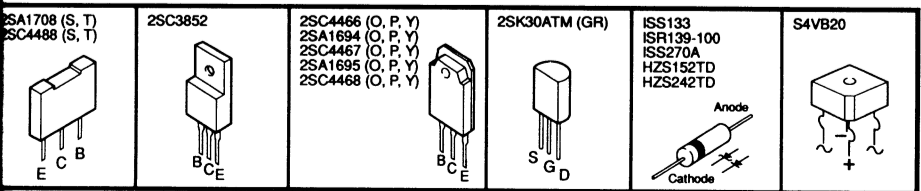

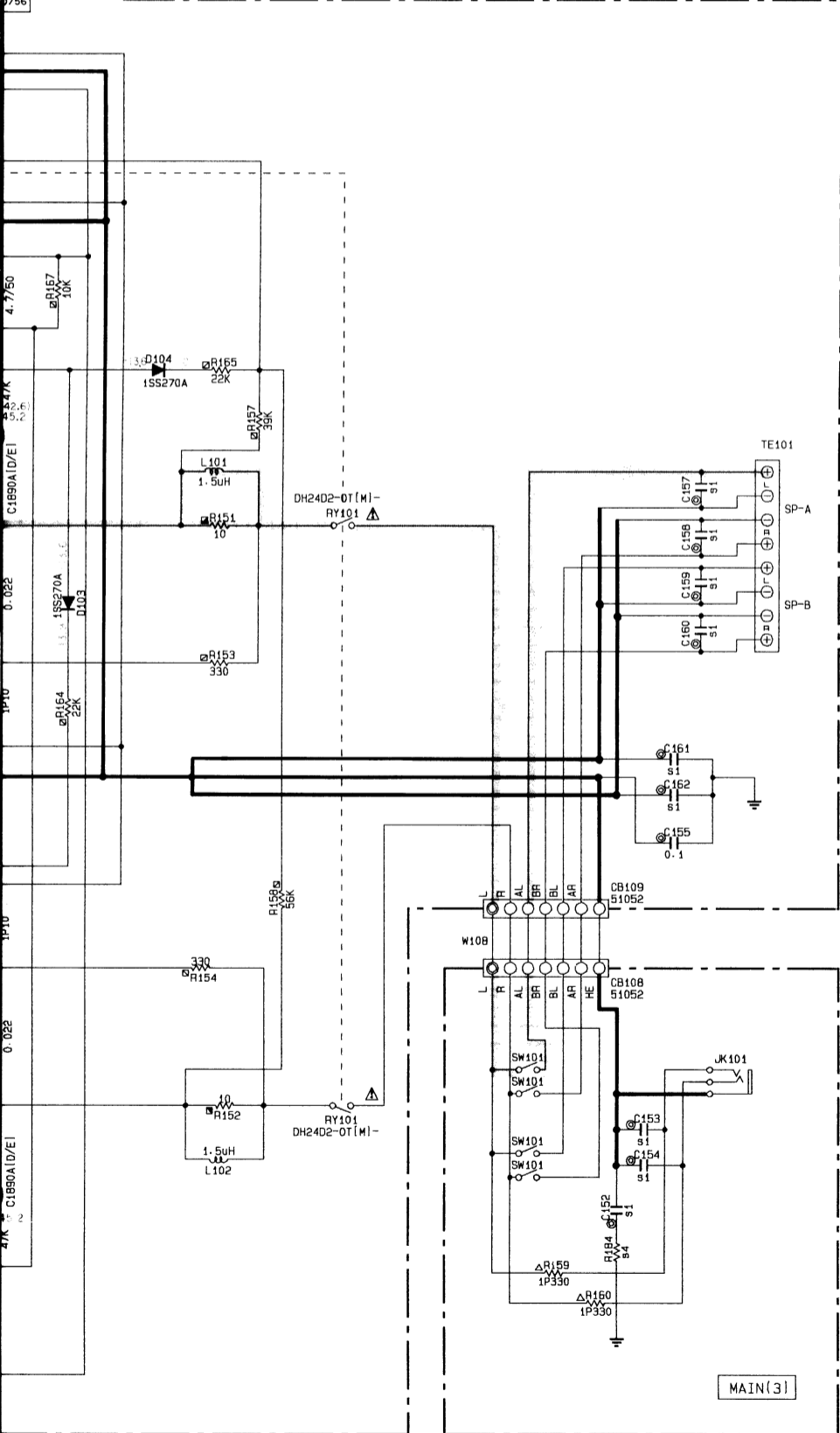
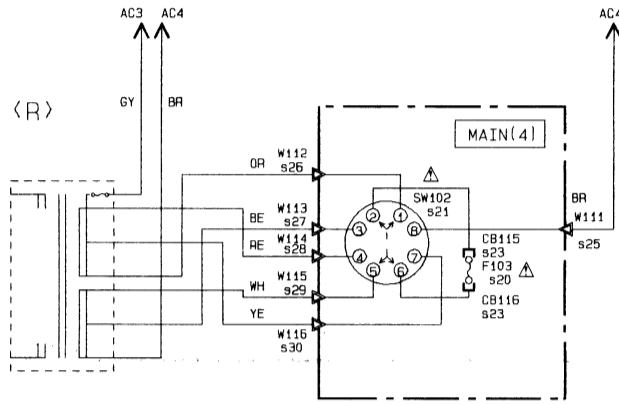
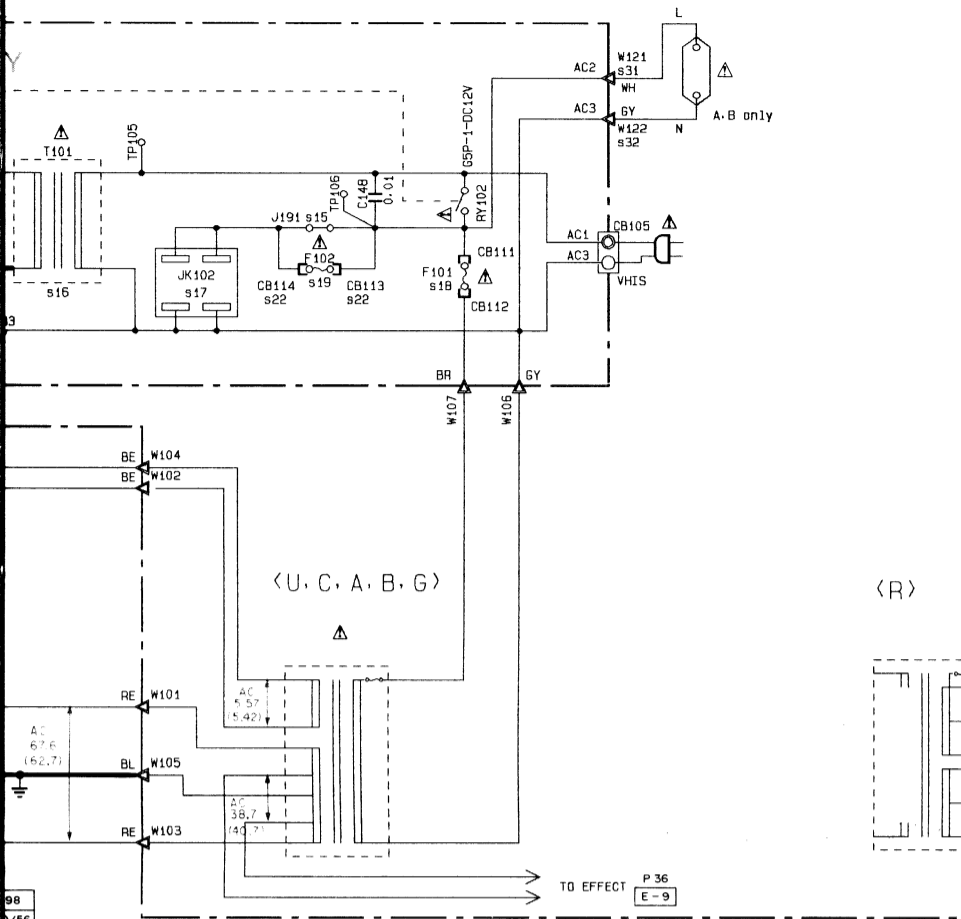

	U	C	R	A-B	G
s1	C152-154, 157-162	X	X	X	0.01
s2	Q129, 130	A1695[D/P/Y] C4468[D/P/Y]	A1694[D/P/Y] C4467[D/P/Y]	A1694[D/P/Y] C4467[D/P/Y]	A1694[D/P/Y] C4467[D/P/Y]
s4	R184	X	X	X	2.2
s5	R183	1/2P2.2M	1/2P2.2M	X	X
s6	R182	X	X	18K	X
s7	R181	X	X	100	X
s8	C149	330/25	330/25	330/63	330/25
s9	C150	X	X	100/16	X
s10	C151	X	X	10/16	X
s11	Q123	X	X	C4466[D/P/Y]	X
s12	Q124	X	X	C1890A[D/E]	X
s13	D114	X	X	HZ5152TD	X
s14	J201	0	0	X	0
s15	J191	0	0	0	X
s16	T101	XC083	XC083	XC082	XC084
s17	JK102	VK48060	VK48060	VK48060	X
s18	F101	5.0A125V	5.0A125V	4A125V	1.6A250V
s19	F102	X	X	X	X
s20	F103	X	X	1.6A250V	X
s21	SW102	X	X	VA96180	X
s22	CB113, 114	X	X	X	X
s23	CB115, 116	X	X	VR31510	X
s24					
s25	W111	X	X	VQ10550	X
s26	W112	X	X	VQ37110	X
s27	W113	X	X	VQ37120	X
s28	W114	X	X	VQ37130	X
s29	W115	X	X	VQ37140	X
s30	W116	X	X	VQ37150	X
s31	W121	X	X	X	VQ10530
s32	W122	X	X	X	VQ10540

Interchangeable Parts at Manufacture-Stage

Mark	Reference Parts Number	Parts Name
k1	Q121	C3852 C4495
k2	D112, 115, 116	HSS104 1SS133 1SS176

- All voltage are measured with a 10MΩ/DC electric volt meter.
- Components having special characteristics are marked Δ and must be replaced with parts having specifications equal to those originally installed.
- Schematic diagram is subject to change without notice.

SCHEMATIC DIAGRAM (EFFECT)

Each voltage indicated here is the value obtained from RX-V480 (R model AC120V).

1

2

3

4

5

6

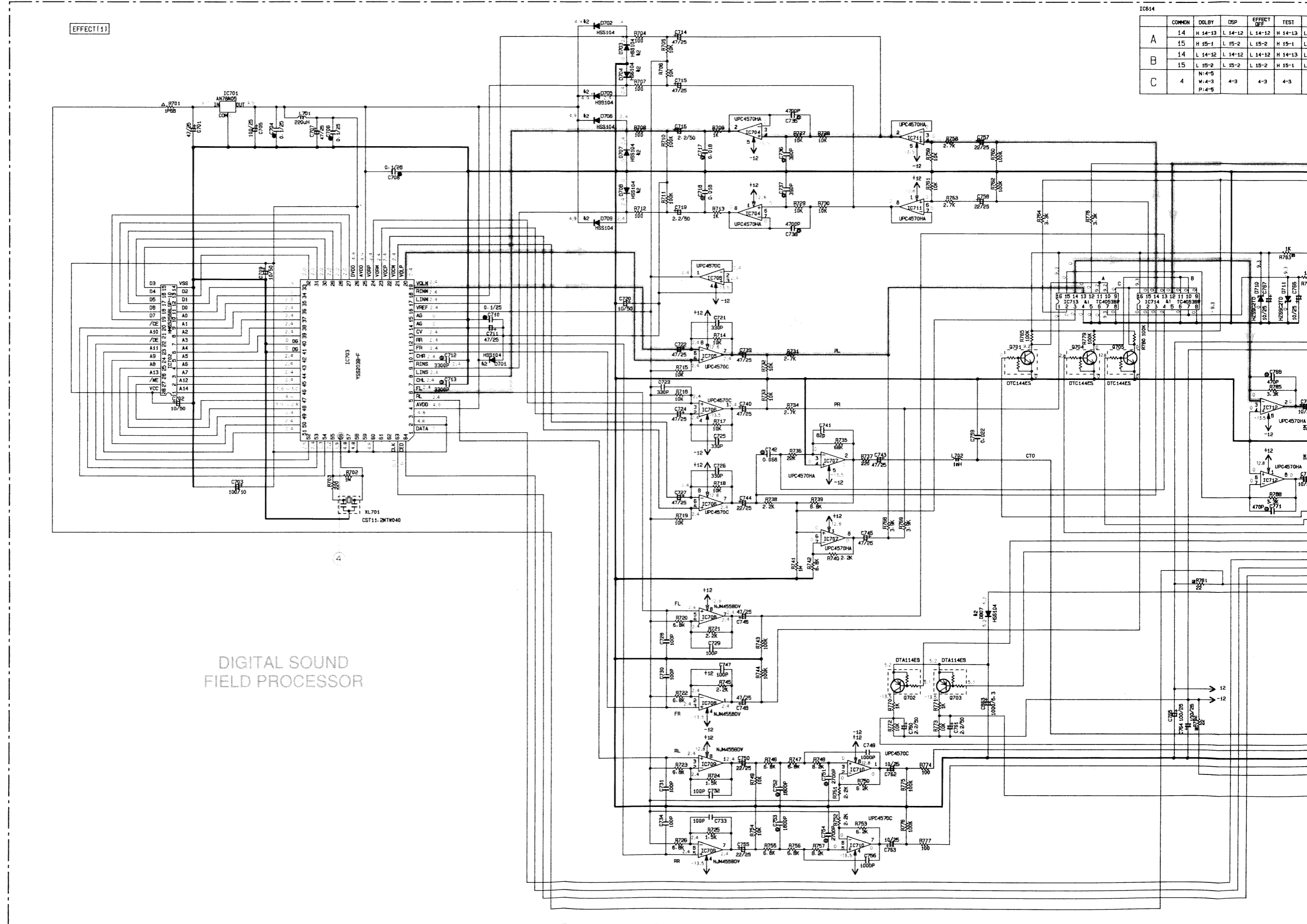

	COMMON	DOLBY	DSP	EFFECT OFF	TEST	PS
A	14	H 14-13	L 14-12	L 14-12	H 14-13	L 14-13
B	15	H 15-1	L 15-2	L 15-2	H 15-1	L 15-1
C	4	N 4-3	4-3	4-3	4-3	4-3

DIGITAL SOUND FIELD PROCESSOR

IC614

	COMMON	DOLBY	OSP	EFFECT OFF	TEST	PS
A	14	H 14-13	L 14-12	L 14-12	H 14-13	L 14-12
	15	H 15-1	L 15-2	L 15-2	H 15-1	L 15-2
B	14	L 14-12	L 14-12	L 14-12	H 14-13	L 14-12
	15	L 15-2	L 15-2	L 15-2	H 15-1	L 15-2
C	4	N:4-5 M:4-3 P:4-5	4-3	4-3	4-3	4-3

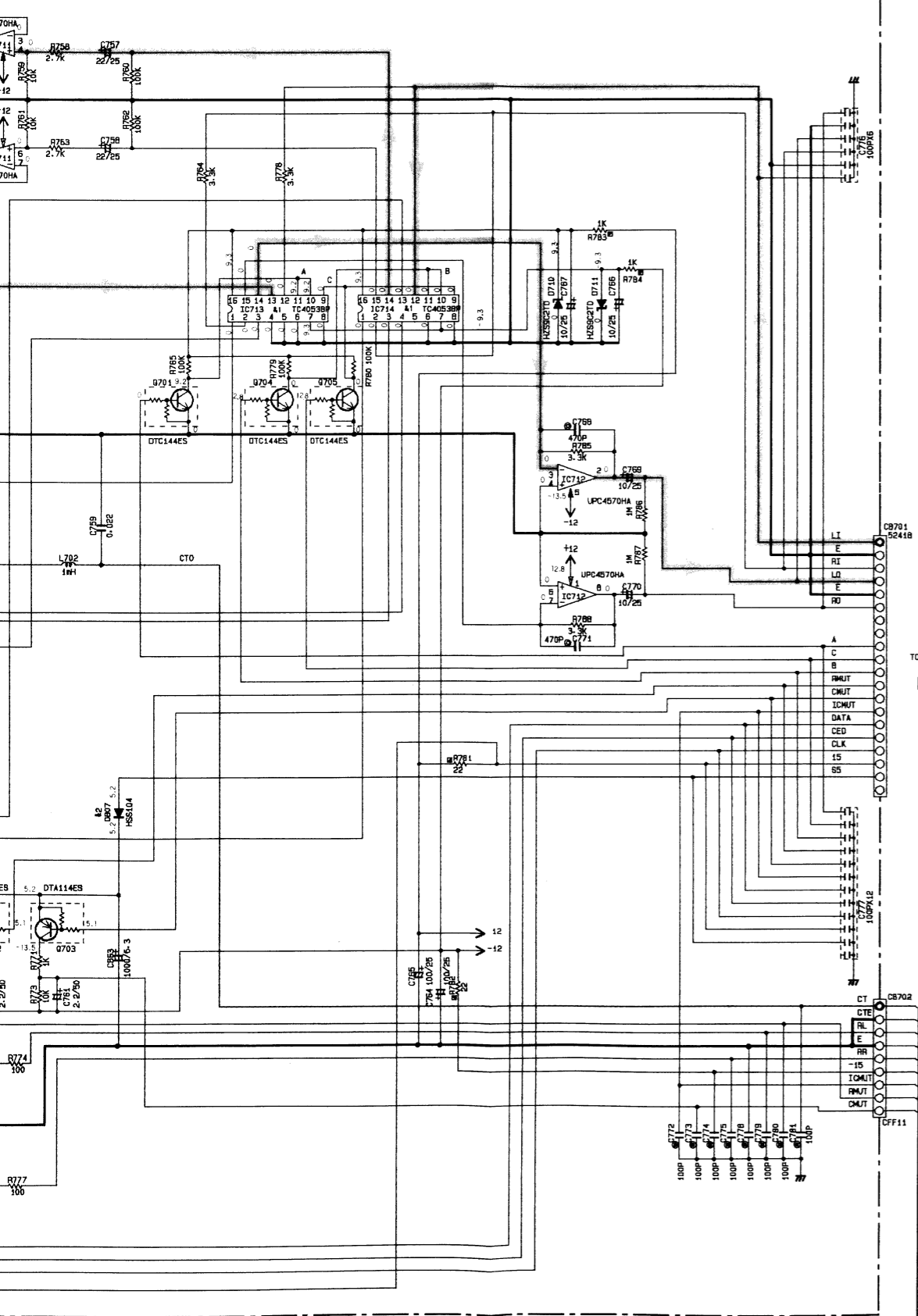

IC704, 707, 711, 712 : μ PC4570HA
Dual OP-Amp

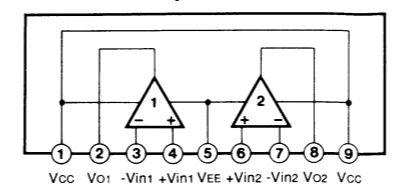

IC705, 706, 710 : μ PC4570C
IC708, 709 : NJM4558DV
Dual OP-Amp

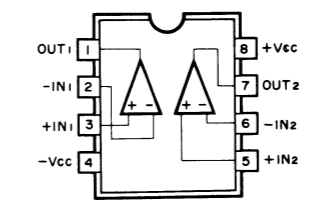

IC855 : LA7956
Video Switch

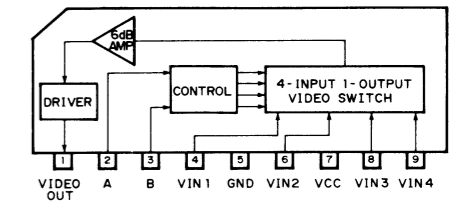

IC702 : HM65256BLSP-10
32768-word x 8-bit High Speed Pseudo Static RAM

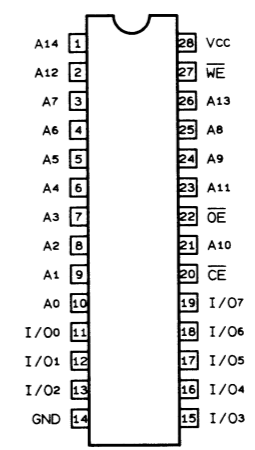
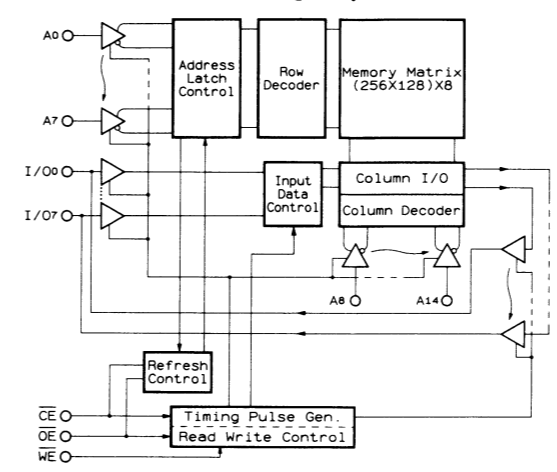

IC713, 714 : TC4053BP
Triple 2 Channel Analog Multiplexers/Demultiplexers

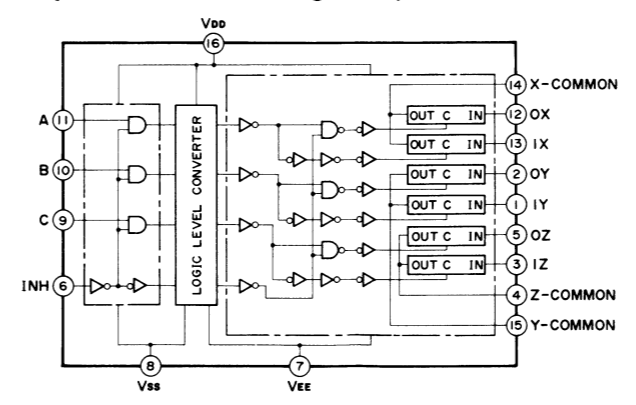

CONTROL INPUTS				"ON" CHANNEL		
INHIBIT (Pin 6)	C (Pin 9)	B (Pin 10)	A (Pin 11)	Ox (Pin 12)	Oy (Pin 2)	Oz (Pin 5)
L	L	L	L	1X	0Y	0Z
L	L	L	H	0X	1Y	0Z
L	L	H	L	1X	0Y	1Z
L	L	H	H	0X	1Y	1Z
L	H	L	L	1X	0Y	1Z
L	H	L	H	0X	1Y	1Z
L	H	H	L	1X	0Y	1Z
L	H	H	H	0X	1Y	1Z
H	.	.	.	NONE	NONE	NONE

* Don't Care

IC802, 803 : μ PC1188H
Power Amp

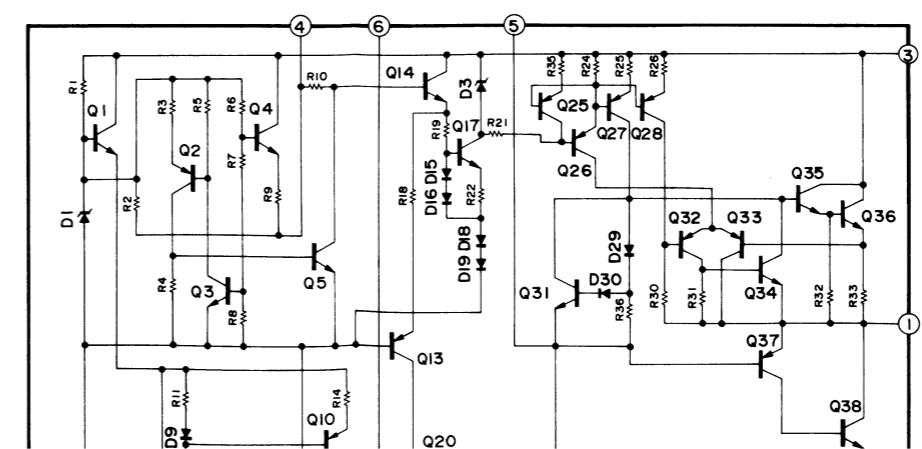

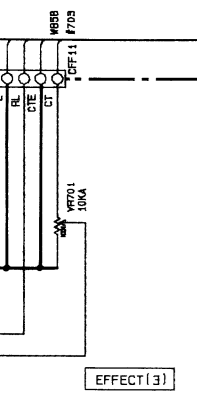
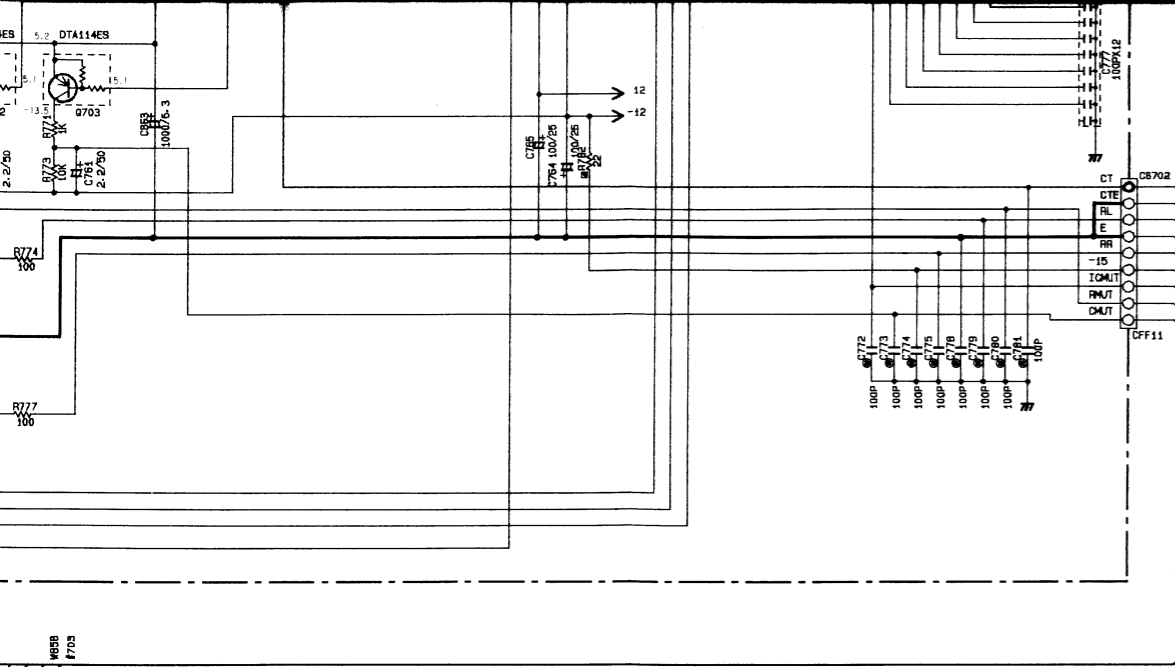

NOTICE
 (J)..... Japanese model
 (U)..... U.S.A model
 (C)..... Canadian model
 (A)..... Australian model
 (G)..... European model
 (B)..... British model
 (R)..... General model
 (P)..... FP model

Interchangeable Parts at Manufacture-Stage

Mark	Reference Parts Number	Parts Name
41	IC713,714	TC4053BP UPD4053BC
42	D701-706, 802, 803, 807	HSS104 ISS133 ISS176

REMARKS	PARTS NAME
NO MARK	CARBON FILM RESISTOR (P=5)
□	CARBON FILM RESISTOR (P=10)
△	METAL OXIDE FILM RESISTOR
▲	METAL FILM RESISTOR
⊠	METAL PLATE RESISTOR
⊞	FIRE PROOF CARBON FILM RESISTOR
⊞	CEMENT MOLDED RESISTOR
⊞	SEMI VARIABLE RESISTOR
■	CHIP RESISTOR

REMARKS	PARTS NAME
NO MARK	ELECTROLYTIC CAPACITOR
⊗	TANTALUM CAPACITOR
NO MARK	CERAMIC CAPACITOR
⊙	CERAMIC TUBULAR CAPACITOR
⊙	POLYESTER FILM CAPACITOR
○	POLYSTYRENE FILM CAPACITOR
⊙	MICA CAPACITOR
⊙	POLYPROPYLENE FILM CAPACITOR
●	SEMICONDUCTIVE CERAMIC CAPACITOR

Q	U.C	R. A. B.	G
1	C831	X	X
2	C829, 832-834	X	X
3	R836	X	X
4	Q805A, 805C	A1895(O/P/Y) C4468(O/P/Y)	A1894(O/P/Y) C4467(O/P/Y)
5	F801, 802	4A125V	X
6	F803, 804	X	2.5A250V
7	C830	X	X
8	C864, 866	X	X
9	R871, 872	X	X
10	C867	X	X
11	R873	X	X
12	R803	1K	1K
13	W899	VR84430	X

**IC802, 803 : μPC1188H
Power Amp**

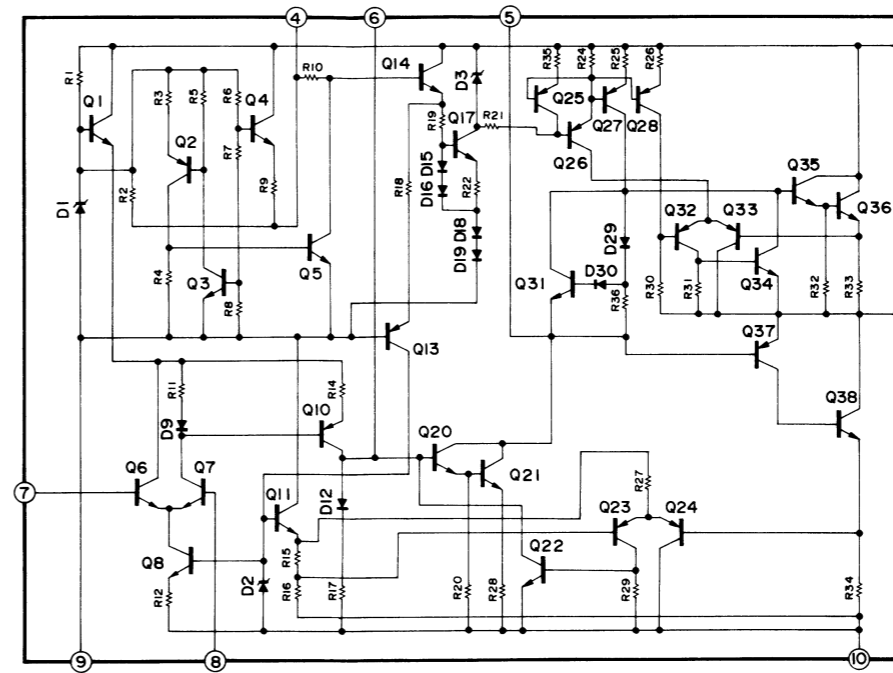

Other IC's

● IC703 : YSS203B → See page 15

Point ④ (Pin 56 of IC703)

V : 2V/div H : 50nsec/div
DC range 1 : 1 probe

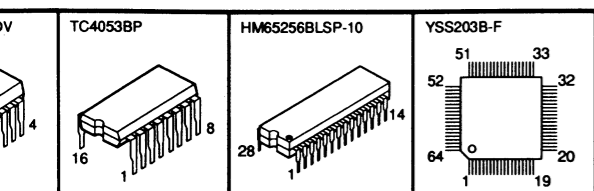
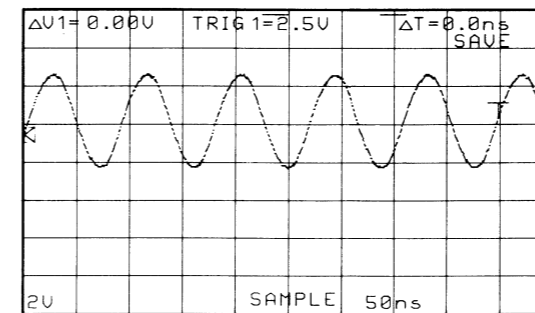

* All voltage are measured with a 10MΩ/DC electric volt meter.
 * Components having special characteristics are marked △ and must be replaced with parts having specifications equal to those originally installed.
 * Schematic diagram is subject to change without notice.

DIGITAL SOUND FIELD PROCESSOR

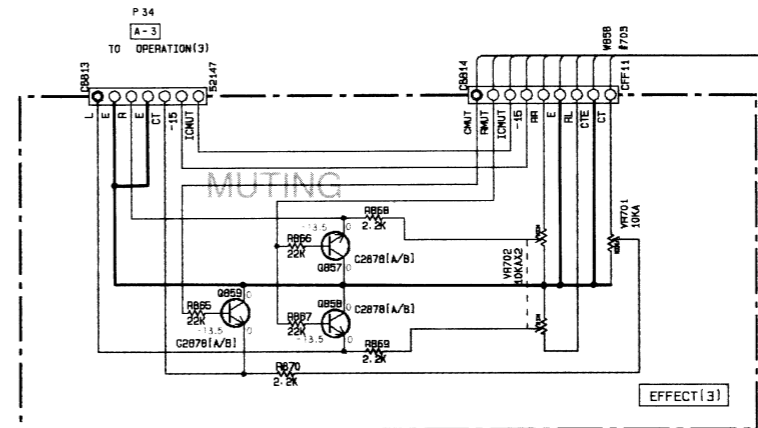
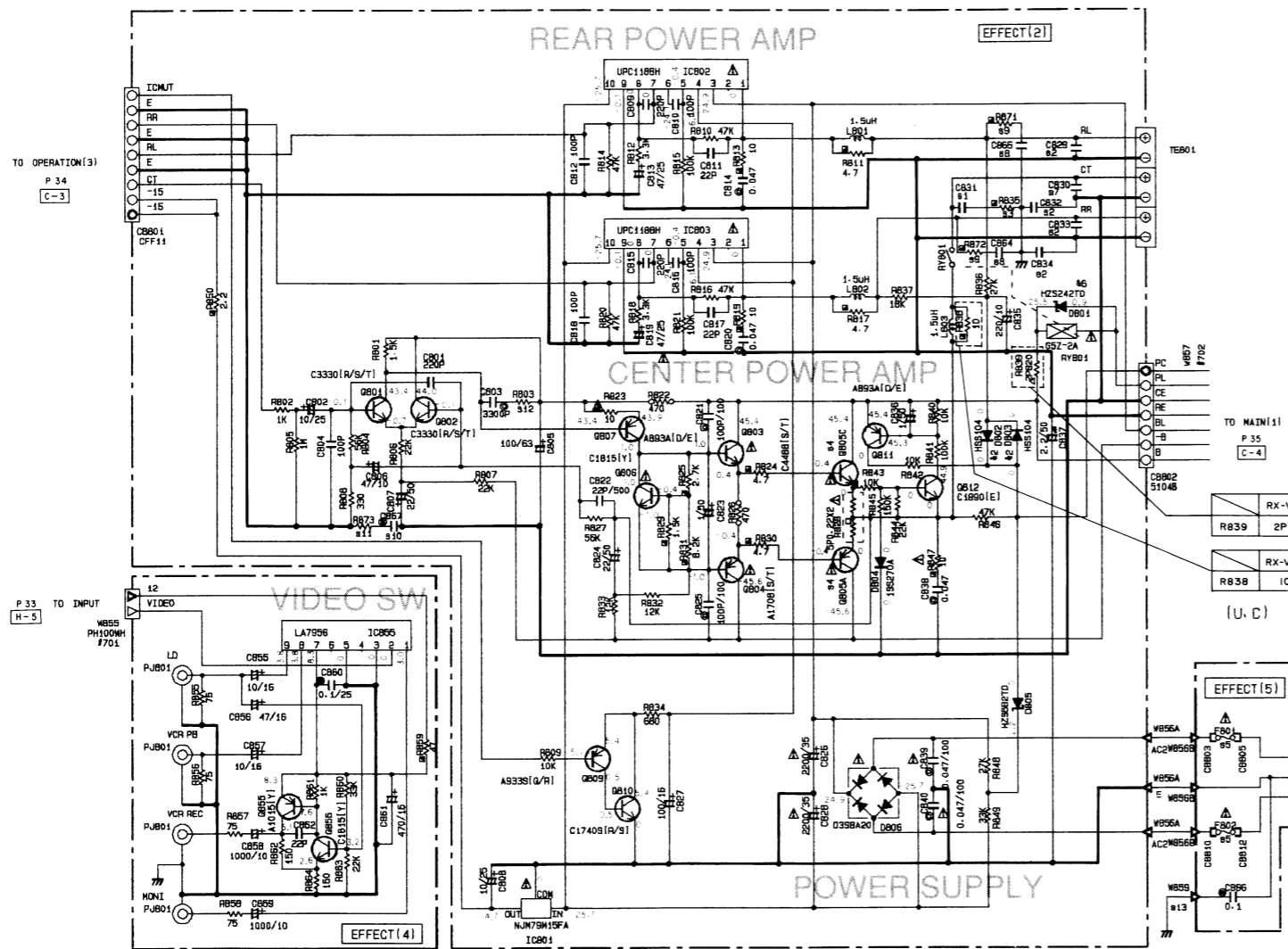
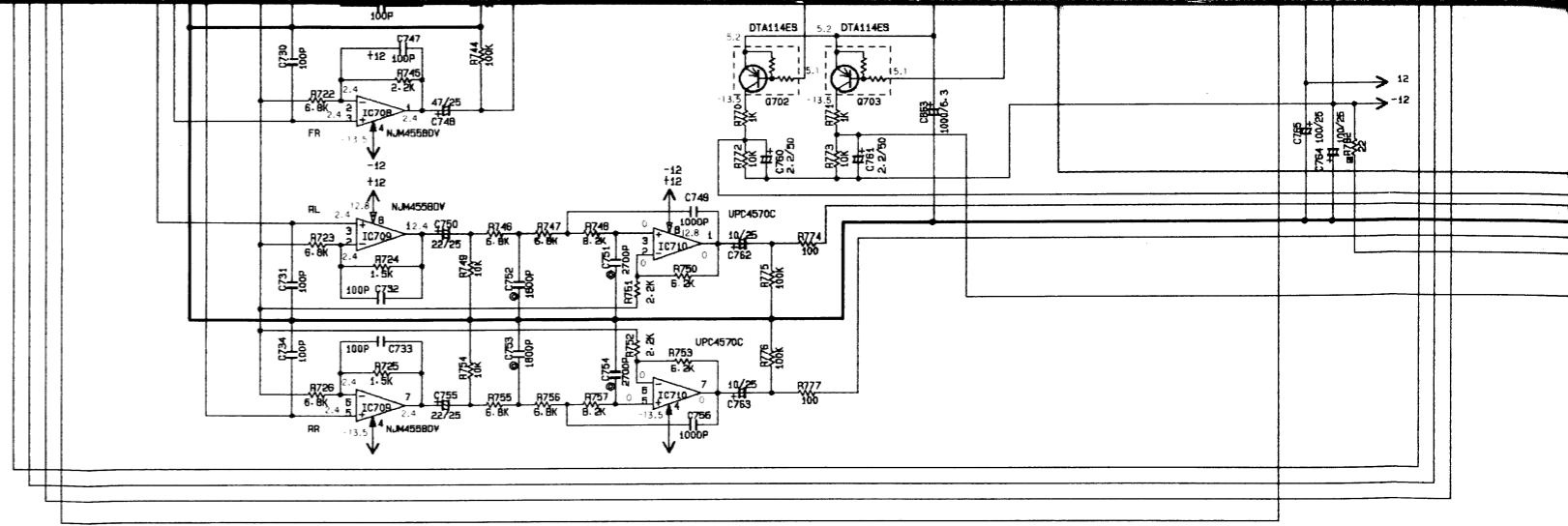

NOTICE
 (J)..... Japanese model
 (U)..... U.S.A model
 (C)..... Canadian model
 (A)..... Australian model
 (G)..... European model
 (B)..... British model
 (R)..... General model
 (P)..... PP model

REMARKS	PARTS NAME
NO MARK	CARBON FILM RESISTOR (P=5)
☑	CARBON FILM RESISTOR (P=10)
△	METAL OXIDE FILM RESISTOR
▲	METAL FILM RESISTOR
⊗	METAL PLATE RESISTOR
⊠	FIRE PROOF CARBON FILM RESISTOR
⊞	CEMENT MOLDED RESISTOR
⊚	SEMI VARIABLE RESISTOR
■	CHIP RESISTOR

REMARKS	PARTS NAME
NO MARK	ELECTROLYTIC CAPACITOR
⊗	TANTALUM CAPACITOR
NO MARK	CERAMIC CAPACITOR
⊙	CERAMIC TUBULAR CAPACITOR
⊚	POLYESTER FILM CAPACITOR
○	POLYSTYRENE FILM CAPACITOR
⊞	MICA CAPACITOR
⊚	POLYPROPYLENE FILM CAPACITOR
●	SEMICONDUCTIVE CERAMIC CAPACITOR

MARK	REFERENCE
41	IC713,714
42	DTA114ES

1	CB31
2	CB29-832-833
3	RB35
4	9805A-802C
5	F801-802
6	F803-804
7	CB30
8	CB4-805
9	RB71-872
10	CB67
11	RB73
12	RB03
13	WB59

PIN CONNECTION DIAGRAM OF TRANSISTORS, DIODES AND ICs.

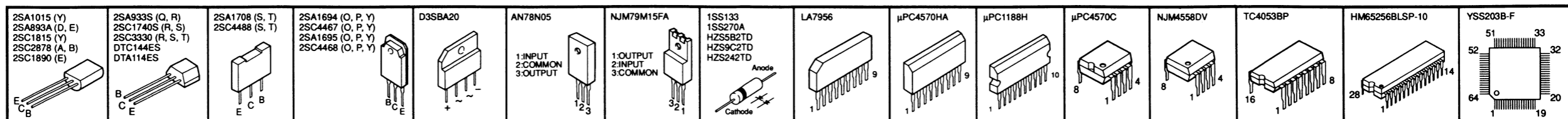

PARTS LIST

■ ELECTRICAL PARTS

■ WARNING

- Components having special characteristics are marked \triangle and must be replaced with parts having specifications equal to those originally installed.
- Carbon resistors (1/6W or 1/4W) are not included in the ELECTRICAL PARTS List. For the parts No. of the carbon resistors, refer to last page.

ABBREVIATIONS IN THIS LIST ARE AS FOLLOWS :

C.A.EL.CHP	: CHIP ALUMI. ELECTROLYTIC CAP	L.EMIT	: LIGHT EMITTING MODULE
C.CE	: CERAMIC CAP	LED.DSPLY	: LED DISPLAY
C.CE.ARRAY	: CERAMIC CAP ARRAY	LED.INFRD	: LED, INFRARED
C.CE.CHP	: CHIP CERAMIC CAP	MODUL.RF	: MODULATOR, RF
C.CE.ML	: MULTILAYER CERAMIC CAP	PHOT.CPL	: PHOTO COUPLER
C.CE.M.CHP	: CHIP MULTILAYER CERAMIC CAP	PHOT.INTR	: PHOTO INTERRUPTER
C.CE.SAFTY	: RECOGNIZED CERAMIC CAP	PHOT.RFLCT	: PHOTO REFLECTOR
C.CE.TUBLR	: CERAMIC TUBULAR CAP	PIN.TEST	: PIN, TEST POINT
C.CE.SMI	: SEMI CONDUCTIVE CERAMIC CAP	PLST.RIVET	: PLASTIC RIVET
C.EL	: ELECTROLYTIC CAP	R.ARRAY	: RESISTOR ARRAY
C.MICA	: MICA CAP	R.CAR.	: CARBON RESISTOR
C.ML.FLM	: MULTILAYER FILM CAP	R.CAR.CHP	: CHIP RESISTOR
C.MP	: METALLIZED PAPER CAP	R.CAR.FP	: FLAME PROOF CARBON RESISTOR
C.MYLAR	: MYLAR FILM CAP	R.FUS	: FUSABLE RESISTOR
C.MYLAR.ML	: MULTILAYER MYLAR FILM CAP	R.MTL.CHP	: CHIP METAL FILM RESISTOR
C.PAPER	: PAPER CAPACITOR	R.MTL.FLM	: METAL FILM RESISTOR
C.PLS	: POLYSTYRENE FILM CAP	R.MTL.OXD	: METAL OXIDE FILM RESISTOR
C.POL	: POLYESTER FILM CAP	R.MTL.PLAT	: METAL PLATE RESISTOR
C.POLY	: POLYETHYLENE FILM CAP	RSNR.CE	: CERAMIC RESONATOR
C.PP	: POLYPROPYLENE FILM CAP	RSNR.CRYS	: CRYSTAL RESONATOR
C.TNTL	: TANTALUM CAP	R.TW.CEM	: TWIN CEMENT FIXED RESISTOR
C.TNTL.CHP	: CHIP TANTALUM CAP	R.WW	: WIRE WOUND RESISTOR
C.TRIM	: TRIMMER CAP	SCR.BND.HD	: BIND HEAD B-TITE SCREW
CN	: CONNECTOR	SCR.BW.HD	: BW HEAD TAPPING SCREW
CN.BS.PIN	: CONNECTOR, BASE PIN	SCR.CUP	: CUP TITE SCREW
CN.CANNON	: CONNECTOR, CANNON	SCR.TERM	: SCREW TERMINAL
CN.DIN	: CONNECTOR, DIN	SCR.TR	: SCREW, TRANSISTOR
CN.FLAT	: CONNECTOR, FLAT CABLE	SUPRT.PCB	: SUPPORT, P.C.B.
CN.POST	: CONNECTOR, BASE POST	SURG.PRTCT	: SURGE PROTECTOR
COIL.MX.AM	: COIL, AM MIX	SW.TACT	: TACT SWITCH
COIL.AT.FM	: COIL, FM ANTENNA	SW.LEAF	: LEAF SWITCH
COIL.DT.FM	: COIL, FM DETECT	SW.LEVER	: LEVER SWITCH
COIL.MX.FM	: COIL, FM MIX	SW.MICRO	: MICRO SWITCH
COIL.OUTPT	: OUTPUT COIL	SW.PUSH	: PUSH SWITCH
DIOD.ARRAY	: DIODE ARRAY	SW.RT.ENC	: ROTARY ENCODER
DIODE.BRG	: DIODE BRIDGE	SW.RT.MTR	: ROTARY SWITCH WITH MOTOR
DIODE.CHP	: CHIP DIODE	SW.RT	: ROTARY SWITCH
DIODE.VAR	: VARACTOR DIODE	SW.SLIDE	: SLIDE SWITCH
DIOD.Z.CHP	: CHIP ZENER DIODE	TERM.SP	: SPEAKER TERMINAL
DIODE.ZENR	: ZENER DIODE	TERM.WRAP	: WRAPPING TERMINAL
DSCR.CE	: CERAMIC DISCRIMINATOR	THRMST.CHP	: CHIP THERMISTOR
FER.BEAD	: FERRITE BEADS	TR.CHP	: CHIP TRANSISTOR
FER.CORE	: FERRITE CORE	TR.DGT	: DIGITAL TRANSISTOR
FET.CHP	: CHIP FET	TR.DGT.CHP	: CHIP DIGITAL TRANSISTOR
FL.DSPLY	: FLUORESCENT DISPLAY	TRANS	: TRANSFORMER
FLTR.CE	: CERAMIC FILTER	TRANS.PULS	: PULSE TRANSFORMER
FLTR.COMB	: COMB FILTER MODULE	TRANS.PWR	: POWER TRANSFORMER ASS'y
FLTR.LC.RF	: LC FILTER ,EMI	TUNER.AM	: TUNER PACK, AM
GND.MTL	: GROUND PLATE	TUNER.FM	: TUNER PACK, FM
GND.TERM	: GROUND TERMINAL	TUNER.PK	: FRONT-END TUNER PACK
HOLDER.FUS	: FUSE HOLDER	VR	: ROTARY POTENTIOMETER
IC.PRTCT	: IC PROTECTOR	VR.MTR	: POTENTIOMETER WITH MOTOR
JUMPER.CN	: JUMPER CONNECTOR	VR.SW	: POTENTIOMETER WITH ROTARY SW
JUMPER.TST	: JUMPER, TEST POINT	VR.SLIDE	: SLIDE POTENTIOMETER
L.DTCT	: LIGHT DETECTING MODULE	VR.TRIM	: TRIMMER POTENTIOMETER

Note) Those parts marked with “#” are not included in the P.C.B. ass'y.

P. C. B. TUNER & MAIN

Schm Ref.	PART NO.	Description
*	VR341800	P. C. B. TUNER (UC)
*	VR341900	P. C. B. TUNER (R)
*	VR342000	P. C. B. TUNER (AB)
*	VR342100	P. C. B. TUNER (G)
CB1	VR428700	CN. BS. PIN 2P
CB2	VR428700	CN. BS. PIN 2P
*	CB4	VQ961800 CN. BS. PIN 15P
C1	UJ638330	C. EL 330uF 16V
C2	VG280100	C. CE. TUBLR 0.022uF 25V
C3	VJ599000	C. CE. TUBLR 0.047uF 16V
C4	VJ836900	C. EL 10uF 16V
C5	VF467300	C. CE. TUBLR 0.01uF 16V
C6	VF964800	C. EL 100uF 16V
C7	VJ839100	C. EL 1uF 50V
C8	VF467300	C. CE. TUBLR 0.01uF 16V
C9	VF467300	C. CE. TUBLR 0.01uF 16V
C10	VF467300	C. CE. TUBLR 0.01uF 16V
C11	VF467000	C. CE. TUBLR 1000pF 50V
C12	VJ836900	C. EL 10uF 16V
C13	VJ836900	C. EL 10uF 16V
C14	VF467000	C. CE. TUBLR 1000pF 50V
C15	VF467000	C. CE. TUBLR 1000pF 50V
C16	VF466700	C. CE. TUBLR 47pF 50V
C17	VF964800	C. EL 100uF 16V
C18	UA655100	C. MYLAR 0.1uF 50V
C19	VA761200	C. CE 33pF 50V
C20	VJ836900	C. EL 10uF 16V
C21	VF466800	C. CE. TUBLR 100pF 50V (UCRAB)
C22	VJ839200	C. EL 2.2uF 50V
C23	VF467300	C. CE. TUBLR 0.01uF 16V
C24	UM416470	C. EL 4.7uF 50V
C25	UM216330	C. EL 3.3uF 50V
C26	VJ836900	C. EL 10uF 16V
C27	VF467300	C. CE. TUBLR 0.01uF 16V
C28	VA761200	C. CE 33pF 50V
C29	VJ839100	C. EL 1uF 50V
C30	VJ839100	C. EL 1uF 50V
C31	VJ836900	C. EL 10uF 16V
C32	VJ839000	C. EL 0.47uF 50V
C33	VJ839100	C. EL 1uF 50V
C34	UA654470	C. MYLAR 0.047uF 50V
*	C35	VD916400 C. EL 2.2uF 50V
*	C36	UA652390 C. MYLAR 390pF 50V (G)
C36	UA652470	C. MYLAR 470pF 50V (AB)
C36	UA652680	C. MYLAR 680pF 50V (UCR)
*	C37	UA652390 C. MYLAR 390pF 50V (G)
C37	UA652470	C. MYLAR 470pF 50V (AB)
C37	UA652680	C. MYLAR 680pF 50V (UCR)
C38	VF466900	C. CE. TUBLR 470pF 50V
C39	VJ836900	C. EL 10uF 16V
C40	UM216330	C. EL 3.3uF 50V
C41	UA653390	C. MYLAR 3900pF 50V

* New Parts

Schm Ref.	PART NO.	Description
C42	VJ836900	C. EL 10uF 16V
C43	UA653390	C. MYLAR 3900pF 50V
C44	UM216330	C. EL 3.3uF 50V
C49	VJ599000	C. CE. TUBLR 0.047uF 16V
C68	VJ836900	C. EL 10uF 16V
C69	VJ836900	C. EL 10uF 16V
C71	VA777400	C. CE 120pF 50V (G)
D1	VD631600	DIODE 1SS133, 176, HSS104
D2	VD631600	DIODE 1SS133, 176, HSS104
D3	VM974500	DIODE. ZENR HZS6C2TD 6.0V
Fi1	GG000560	FLTR. CE SFE10.7MS3GHY-A
Fi2	GG000560	FLTR. CE SFE10.7MS3GHY-A
Fi3	VC219000	FLTR. CE SFZ450JL3
IC1	XB760A00	IC LA1266
IC2	XB818A00	IC LM7000N
IC3	iG158100	IC LA3401
L1	Vi546100	COIL 220uH
L2	Vi546100	COIL 220uH
L3	Vi546100	COIL 220uH
* PK1	VQ987600	TUNER. PK EXV-17296G1 (G)
* PK1	VR242200	TUNER. PK EXV-17296G1 (UCRAB)
PK2	Vi027300	COIL. AM
Q1	iC053540	TR 2SC535 A, B, C
Q2	VC218900	TR 2SC3330 R, S, T
Q3	VC218900	TR 2SC3330 R, S, T
Q4	iC053540	TR 2SC535 A, B, C
Q5	VC218700	TR 2SA1317 R, S, T
Q6	VC218900	TR 2SC3330 R, S, T
Q7	iC1815C0	TR 2SC1815 Y
SW1	VF541200	SW. SLIDE SSSF11 (R)
T1	VC218600	COIL. DT. FM 10.7MHz
T2	GE100470	COIL. IF. AM 450KHz
* T3	VQ365700	FLTR. LP FB-75G (G)
* T4	VQ138200	FLTR. LC 19KHz
* T5	VQ138200	FLTR. LC 19KHz
TE1	LA005800	TERM. ANT YKD31-0215
TP1	LA004120	PIN. TEST
TP2	LA004120	PIN. TEST
VR1	VJ694000	VR. TRIM B47K Ω
VR2	VJ694000	VR. TRIM B47K Ω
XL1	QU003800	RSNR. CRYST 7.2MHz
XL2	GG000750	RSNR. CE 18.95MHz
	BB071360	SCR. TERM 8.3x13
*	VR282500	PLATE ANT.
*	VR341000	P. C. B. MAIN :RX-V480 (U)
*	VR341100	P. C. B. MAIN :RX-V480 (R)
*	VR341200	P. C. B. MAIN :RX-V480 (AB)
*	VR341300	P. C. B. MAIN :RX-V480 (G)
*	VR342700	P. C. B. MAIN :R-V98 (UC)

* New Parts

RX-V480/R-V98

P. C. B. MAIN

Schm Ref.	PART NO.	Description		
	VR369700	P. C. B.	MAIN :RX-V480(C)	
* CB101	VK024900	CN. BS. PIN	5P	
* CB102	VR358000	CN. BS. PIN	9P	
CB103	VP768100	CN. BS. PIN	5P	
CB105	VG879900	CN. BS. PIN	2P	
* CB107	VK025100	CN. BS. PIN	7P	
* CB108	VQ584900	CN. BS. PIN	7P	
* CB109	VQ584900	CN. BS. PIN	7P	
* CB111	VP206500	HOLDER. FUS		
* CB112	VP206500	HOLDER. FUS		
* CB113	VP206500	HOLDER. FUS	(G)	
* CB114	VP206500	HOLDER. FUS	(G)	
* CB115	VP206500	HOLDER. FUS	(R)	
* CB116	VP206500	HOLDER. FUS	(R)	
C101	UM416470	C. EL	4.7uF	50V
C102	UM416470	C. EL	4.7uF	50V
C103	UA652100	C. MYLAR	100pF	50V
C104	UA652100	C. MYLAR	100pF	50V
C105	FG211330	C. CE	33pF	50V:R-V98
C105	VE551900	C. CE	100pF	50V:RX-V480
C106	FG211330	C. CE	33pF	50V:R-V98
C106	VE551900	C. CE	100pF	50V:RX-V480
C107	UA653100	C. MYLAR	1000pF	50V
C108	UA653100	C. MYLAR	1000pF	50V
C109	VJ837200	C. EL	47uF	16V
C110	VJ837200	C. EL	47uF	16V
* C111	VR516400	C. CE	15p	500V
* C112	VR516400	C. CE	15p	500V
C113	UJ667470	C. EL	47uF	50V
C114	UJ667470	C. EL	47uF	50V
C115	UJ667470	C. EL	47uF	50V
C116	UJ667470	C. EL	47uF	50V
* C117	VR325000	C. MYLAR	100pF	100V
* C118	VR325000	C. MYLAR	100pF	100V
* C119	VR325000	C. MYLAR	100pF	100V
* C120	VR325000	C. MYLAR	100pF	100V
C121	UA654820	C. MYLAR	0.082uF	50V
C122	UA654820	C. MYLAR	0.082uF	50V
C123	UA655100	C. MYLAR	0.1uF	50V
C124	UA655100	C. MYLAR	0.1uF	50V
C125	UA654220	C. MYLAR	0.022uF	50V
C126	UA654220	C. MYLAR	0.022uF	50V
C127	UA652100	C. MYLAR	100pF	50V
* C129	VK182500	C. EL	330uF	63V
C130	UJ895220	C. EL	0.22uF	100V
C131	UM416470	C. EL	4.7uF	50V
C132	VF760000	C. EL	100uF	10V
C133	VF760000	C. EL	100uF	10V
C134	UM416470	C. EL	4.7uF	50V
C135	UM416470	C. EL	4.7uF	50V
△ C136	Vi846000	C. EL	22uF	63V
C137	UM416470	C. EL	4.7uF	50V

* New Parts

Schm Ref.	PART NO.	Description		
C138	UJ667470	C. EL	47uF	50V
C139	UJ667470	C. EL	47uF	50V
△ * C140	VR024000	C. EL	6800uF	56V:R-V98
△ * C140	VR670100	C. EL	8200uF	56V:RX-V480
△ * C141	VR024000	C. EL	6800uF	56V:R-V98
△ * C141	VR670100	C. EL	8200uF	56V:RX-V480
△ * C142	VR325400	C. MYLAR	0.1uF	100V
△ * C143	VR325400	C. MYLAR	0.1uF	100V
C145	UG444100	C. CE	0.01uF	50V
C146	FG213100	C. CE	1000pF	50V
C147	UA654100	C. MYLAR	0.01uF	50V
C148	Fi514100	C. CE. SAFTY	0.01uF	VA-1
△ * C149	VK182500	C. EL	330uF	63V(R)
△ C149	VK457600	C. EL	330uF	25V(UCABG)
C150	VF964800	C. EL	100uF	16V(R)
C151	VJ836900	C. EL	10uF	16V(R)
C152	UA654100	C. MYLAR	0.01uF	50V(G)
C153	UA654100	C. MYLAR	0.01uF	50V(G)
C154	UA654100	C. MYLAR	0.01uF	50V(G)
C155	UA655100	C. MYLAR	0.1uF	50V
C157	UA654100	C. MYLAR	0.01uF	50V(G)
C158	UA654100	C. MYLAR	0.01uF	50V(G)
C159	UA654100	C. MYLAR	0.01uF	50V(G)
C160	UA654100	C. MYLAR	0.01uF	50V(G)
C161	UA654100	C. MYLAR	0.01uF	50V(G)
C162	UA654100	C. MYLAR	0.01uF	50V(G)
C164	UM416470	C. EL	4.7uF	50V
* C165	UK665470	C. EL	0.47uF	50V
D101	VN008700	DIODE	1SS270A	
D102	VN008700	DIODE	1SS270A	
D103	VN008700	DIODE	1SS270A	
D104	VN008700	DIODE	1SS270A	
* D106	VM976300	DIODE. ZENR	HZS242TD	24V
* D107	VM976300	DIODE. ZENR	HZS242TD	24V
△ D108	VH770800	DIODE	1SR139-100	
D109	VM975800	DIODE. ZENR	HZS152TD	15V
D110	VM975800	DIODE. ZENR	HZS152TD	15V
△ D111	iH001090	DIODE. BRG	S4VB20	2.6A 200V
D112	VD631600	DIODE	1SS133, 176, HSS104	
△ D113	VH770800	DIODE	1SR139-100	
D114	VM975800	DIODE. ZENR	HZS152TD	15V(R)
D115	VD631600	DIODE	1SS133, 176, HSS104	
D116	VD631600	DIODE	1SS133, 176, HSS104	
△ F101	KB003060	FUSE	TL1.6A	250V(ABG)
△ F101	KB003620	FUSE	T4.0A	125V(R)
△ F101	KB003630	FUSE	5.0A	125V:V480(UC)
△ F101	KB003640	FUSE	T6.0A	125V:R-V98
△ F102	KB000690	FUSE	T2.5A	250V(G)
△ F103	KB003060	FUSE	TL1.6A	250V(R)
△ FR101	VK188400	R. FUS	330Ω	1/4W
△ FR102	VK188400	R. FUS	330Ω	1/4W
△ FR103	VK189000	R. FUS	1KΩ	1/4W

* New Parts

P. C. B. MAIN & OPERATION

Schm Ref.	PART NO.	Description		
	FR104	VK189000	R. FUS	1KΩ 1/4W
	JK101	LB301720	JACK. PHONE	
Δ	JK102	VK480600	OUTLET. AC	(UCR)
Δ	JK102	VK480700	OUTLET. AC	(G)
*	L101	VP575600	COIL	1.5uH
*	L102	VP575600	COIL	1.5uH
Δ*	Q101	VP883000	TR	2SA893A D, E
Δ*	Q102	VP883000	TR	2SA893A D, E
Δ*	Q103	VP883000	TR	2SA893A D, E
Δ*	Q104	VP883000	TR	2SA893A D, E
Δ*	Q105	VR325600	TR	2SC2229 O, Y
Δ*	Q106	VR325600	TR	2SC2229 O, Y
Δ	Q107	VC218900	TR	2SC3330 R, S, T
Δ	Q108	VC218900	TR	2SC3330 R, S, T
Δ*	Q109	VP872700	TR	2SC4488 S, T
Δ*	Q110	VP872700	TR	2SC4488 S, T
Δ*	Q111	VP872600	TR	2SA1708 S, T
Δ*	Q112	VP872600	TR	2SA1708 S, T
*	Q113	VP883100	TR	2SC1890A D, E
*	Q114	VP883100	TR	2SC1890A D, E
*	Q115	VP883000	TR	2SA893A D, E
	Q116	VC218900	TR	2SC3330 R, S, T
	Q117	VC218900	TR	2SC3330 R, S, T
	Q118	iC287820	TR	2SC2878 A, B
	Q119	VC218900	TR	2SC3330 R, S, T
Δ	Q120	iA101521	TR	2SA1015 Y
Δ	Q121	VC938500	TR	2SC3852
	Q122	VC218900	TR	2SC3330 R, S, T
	Q123	VP768300	TR	2SC4466 O, P, Y(R)
*	Q124	VP883100	TR	2SC1890A D, E(R)
	Q127	VG722000	TR. DGT	DTC144ES
Δ	Q128	iB056020	TR	2SB560 E, F
Δ&	Q129A	iX615750	TR	2SA1694 O, P, Y
Δ&	Q129C	iX615760	TR	2SC4467 O, P, Y
Δ<	Q129A	iX630850	TR	2SA1695 O, P, Y
Δ<	Q129C	iX630860	TR	2SC4468 O, P, Y
Δ&	Q130A	iX615750	TR	2SA1694 O, P, Y
Δ&	Q130C	iX615760	TR	2SC4467 O, P, Y
Δ<	Q130A	iX630850	TR	2SA1695 O, P, Y
Δ<	Q130C	iX630860	TR	2SC4468 O, P, Y
	Q131	VK432900	TR	2SD1915F S, T
	Q132	VK432900	TR	2SD1915F S, T
	Q133	iE000020	FET	2SK30ATM GR
Δ	R113	HV454470	R. CAR. FP	47Ω 1/4W
Δ	R114	HV454470	R. CAR. FP	47Ω 1/4W
	R127	HV456270	R. CAR. FP	2.7KΩ 1/4W
	R128	HV456270	R. CAR. FP	2.7KΩ 1/4W
	R131	HV456100	R. CAR. FP	1KΩ 1/4W
	R132	HV456100	R. CAR. FP	1KΩ 1/4W
	R133	HV453470	R. CAR. FP	4.7Ω 1/4W
	R134	HV453470	R. CAR. FP	4.7Ω 1/4W
	R135	HV453470	R. CAR. FP	4.7Ω 1/4W

* New Parts

(Note) Δ : RX-V480 (C, R, A, B, G)
 < : RX-V480 (U), R-V98

Schm Ref.	PART NO.	Description		
	R136	HV453470	R. CAR. FP	4.7Ω 1/4W
Δ*	R137	HZ003780	R. MTL. PLAT	0.22Ω+0.22 5W
Δ*	R138	HZ003780	R. MTL. PLAT	0.22Ω+0.22 5W
Δ	R145	HL314100	R. MTL. OXD	10Ω 1W
Δ	R146	HL314100	R. MTL. OXD	10Ω 1W
	R151	HV454100	R. CAR. FP	10Ω 1/4W
	R152	HV454100	R. CAR. FP	10Ω 1/4W
	R159	HL315330	R. MTL. OXD	330Ω 1W:RX-V480
	R159	VP944500	R. MTL. OXD	390Ω 1W:R-V98
	R160	HL315330	R. MTL. OXD	330Ω 1W:RX-V480
	R160	VP944500	R. MTL. OXD	390Ω 1W:R-V98
Δ	R163	HL314470	R. MTL. OXD	47Ω 1W
Δ	R171	HL315560	R. MTL. OXD	560Ω 1W:RX-V480
Δ	R171	HL315680	R. MTL. OXD	680Ω 1W:R-V98
	R173	HV456100	R. CAR. FP	1KΩ 1/4W
Δ	R177	HV453100	R. CAR. FP	1Ω 1/4W
Δ	R178	HV454100	R. CAR. FP	10Ω 1/4W
	R179	HV457100	R. CAR. FP	10KΩ 1/4W
	R189	HL315680	R. MTL. OXD	680Ω 1W
Δ	RY101	VK438300	RELAY	DH24D2-OTM-
Δ	RY102	VH230800	RELAY	G5P-1-DC12V
	SW101	VJ850200	SW. PUSH	PSE021A2KP 2
Δ	SW102	VA961800	VOLT. SELCT	ESE-37247-F(R)
Δ	T101	XC082A00	TRANS. PWR	(R)
Δ	T101	XC083A00	TRANS. PWR	(UC)
Δ	T101	XC084A00	TRANS. PWR	(AGB)
Δ	TE101	VN286300	TERM. SP	8P
		VJ828000	PIN	IMSA-6024-03E
		BB071360	SCR. TERM	8.3x13(ABG)
		VP753100	HEAT. SINK	IC-1625-MML
		BB069510	GND. MTL	No. 6951
		E1330166	SCR. BND. HD	3x16 FCRM3-BL
*		VR341400	P. C. B.	OPERATION(UC)
*		VR341500	P. C. B.	OPERATION(R)
*		VR341600	P. C. B.	OPERATION(AB)
*		VR341700	P. C. B.	OPERATION(G)
*	CB301	VR361600	CN. BS. PIN	9P
*	CB302	VR362600	CN. BS. PIN	19P
*	CB401	Vi878300	CN. BS. PIN	5P
*	CB402	Vi878500	CN. BS. PIN	7P
*	CB403	Vi878500	CN. BS. PIN	7P
*	CB404	VR358000	CN. BS. PIN	9P
	C301	VJ836900	C. EL	10uF 16V
	C302	VJ839100	C. EL	1uF 50V
	C303	VJ839100	C. EL	1uF 50V
*	C304	VR357400	C. EL	4700uF 5.5V
	C305	VD930900	C. CE. SMI	0.1uF 25V
	C306	VH053100	C. CE. TUBLR	0.1uF 50V
	C401	VJ839000	C. EL	0.47uF 50V

* New Parts

RX-V480/R-V98

P. C. B. OPERATION & INPUT

Schm Ref.	PART NO.	Description		
C402	VJ839000	C. EL	0.47uF	50V
C403	UA652100	C. MYLAR	100pF	50V
C404	UA652100	C. MYLAR	100pF	50V
C405	VJ837200	C. EL	47uF	16V
C406	VJ837200	C. EL	47uF	16V
C407	UA652100	C. MYLAR	100pF	50V
C408	UA652100	C. MYLAR	100pF	50V
C409	VJ839200	C. EL	2.2uF	50V
C410	VJ839200	C. EL	2.2uF	50V
C411	VE551500	C. CE	47pF	50V
C412	VE551500	C. CE	47pF	50V
C413	UM407220	C. EL	22uF	25V
C414	UM407220	C. EL	22uF	25V
C415	UA655120	C. MYLAR	0.12uF	50V
C416	UA655120	C. MYLAR	0.12uF	50V
C417	UA654330	C. MYLAR	0.033uF	50V
C418	UA654330	C. MYLAR	0.033uF	50V
C419	UM417100	C. EL	10uF	50V
C420	UM417100	C. EL	10uF	50V
C421	UA652330	C. MYLAR	330pF	50V
C422	UA652330	C. MYLAR	330pF	50V
C423	VE551900	C. CE	100pF	50V
C424	VE551900	C. CE	100pF	50V
C425	UM417100	C. EL	10uF	50V
C426	UM417100	C. EL	10uF	50V
* C427	VG722100	C. EL	1uF	50V
D301	VM974600	DIODE. ZENR	HZS7A2TD	7.0V
D302	VM974200	DIODE. ZENR	HZS5C2TD	5.0V
D303	VD631600	DIODE	1SS133, 176, HSS104	
D304	VD631600	DIODE	1SS133, 176, HSS104	
D305	VP594000	LED (re)	SLR-305VCA47 (G)	
D306	VD631600	DIODE	1SS133, 176, HSS104	
D307	VD631600	DIODE	1SS133, 176, HSS104	
D308	VD631600	DIODE	1SS133, 176, HSS104	
D309	VD631600	DIODE	1SS133, 176, HSS104	
D310	VD631600	DIODE	1SS133, 176, HSS104	
D311	VM974300	DIODE. ZENR	HZS6A2TD	6.0V
D312	VD631600	DIODE	1SS133, 176, HSS104	
* IC301	XN332A00	IC	M38102M4-614SP	
IC401	XM356A00	IC	NJM2068LD	
IC402	XM356A00	IC	NJM2068LD	
Q301	iC174020	TR	2SC1740S R, S	
Q302	iA093320	TR	2SA933S Q, R	
Q303	iC174020	TR	2SC1740S R, S	
Q304	iC174020	TR	2SC1740S R, S(G)	
Q305	VD678500	TR. DGT	DTA114ES	
SW301	VG392900	SW. TACT	SKHVAA	
SW302	VG392900	SW. TACT	SKHVAA	
SW303	VG392900	SW. TACT	SKHVAA	
SW304	VG392900	SW. TACT	SKHVAA	
SW305	VG392900	SW. TACT	SKHVAA	
SW306	VG392900	SW. TACT	SKHVAA	

* New Parts

Schm Ref.	PART NO.	Description		
SW307	VG392900	SW. TACT	SKHVAA	
SW308	VG392900	SW. TACT	SKHVAA	
SW309	VG392900	SW. TACT	SKHVAA	
SW310	VG392900	SW. TACT	SKHVAA	
SW311	VG392900	SW. TACT	SKHVAA	
SW312	VG392900	SW. TACT	SKHVAA	
SW313	VG392900	SW. TACT	SKHVAA	
SW314	VG392900	SW. TACT	SKHVAA	
SW315	VG392900	SW. TACT	SKHVAA	
SW316	VG392900	SW. TACT	SKHVAA	
SW317	VG392900	SW. TACT	SKHVAA	
SW318	VG392900	SW. TACT	SKHVAA	
SW319	VG392900	SW. TACT	SKHVAA	
SW320	VG392900	SW. TACT	SKHVAA	
* U301	VR023400	L. DETCT	SPS-424-1	
* V301	VR061700	FL. DSPLY	13-MT-71GK	
* VR401	VP741800	VR	B20K Ω	
* VR402	VP741900	VR	G25K Ω	
* VR403	VP742000	VR	MN50K Ω	
* VR404	VQ647000	VR. MTR	A100K Ω	
XL301	VE906000	RSNR. CE	4MHz	
	VJ828000	PIN	IMSA-6024-03E	
* VR380100		SPACER		
* VR011400		SHEET. FL		
* VR342200		P. C. B.	INPUT (UCRAB)	
* VR342300		P. C. B.	INPUT (G)	
* CB501	VQ963600	CN. BS. PIN	15P	
* CB502	VR359000	CN. BS. PIN	19P	
* CB503	VQ962300	CN. BS. PIN	20P	
CB504	VD004500	CN. BS. PIN	2P	
* CB505	VK025100	CN. BS. PIN	7P	
C501	UA652220	C. MYLAR	220pF	50V (G)
C502	UA652220	C. MYLAR	220pF	50V
C503	UA652220	C. MYLAR	220pF	50V (G)
C504	UA652220	C. MYLAR	220pF	50V
C505	UA652220	C. MYLAR	220pF	50V
C506	UA652220	C. MYLAR	220pF	50V
C507	VG278400	C. CE. TUBLR	220pF	50V
C508	VG278400	C. CE. TUBLR	220pF	50V
C509	VG278400	C. CE. TUBLR	220pF	50V
C510	VG278400	C. CE. TUBLR	220pF	50V
C511	VG278400	C. CE. TUBLR	220pF	50V
C512	VG278400	C. CE. TUBLR	220pF	50V
C513	VG278400	C. CE. TUBLR	220pF	50V
C514	VG278400	C. CE. TUBLR	220pF	50V
C515	VG278400	C. CE. TUBLR	220pF	50V
C516	VG278400	C. CE. TUBLR	220pF	50V
C517	VE117600	C. EL	220uF	10V
C518	UA653910	C. MYLAR	9100pF	50V

* New Parts

P. C. B. INPUT & EFFECT

Schm Ref.	PART NO.	Description		
C519	UA654330	C. MYLAR	0.033uF	50V
C520	UA653910	C. MYLAR	9100pF	50V
C521	UA654330	C. MYLAR	0.033uF	50V
C522	VE117600	C. EL	220uF	10V
C523	VJ839200	C. EL	2.2uF	50V
C524	VJ837200	C. EL	47uF	16V
C525	VJ837200	C. EL	47uF	16V
C526	VJ839200	C. EL	2.2uF	50V
C527	VG290900	C. EL	10uF	50V
C528	VG290900	C. EL	10uF	50V
C529	VJ836900	C. EL	10uF	16V
C530	VG290900	C. EL	10uF	50V
C531	VJ837200	C. EL	47uF	16V
C532	VJ837200	C. EL	47uF	16V
C533	VG290900	C. EL	10uF	50V
C534	VJ837200	C. EL	47uF	16V
C535	VH053100	C. CE. TUBLR	0.1uF	50V
C536	VG277700	C. CE. TUBLR	68pF	50V
C537	VF467300	C. CE. TUBLR	0.01uF	16V
C538	VF964800	C. EL	100uF	16V
C541	VH053100	C. CE. TUBLR	0.1uF	50V
C542	VF466800	C. CE. TUBLR	100pF	50V
C543	VF467300	C. CE. TUBLR	0.01uF	16V
C544	VE117600	C. EL	220uF	10V
C545	VH053100	C. CE. TUBLR	0.1uF	50V
C548	VG278600	C. CE. TUBLR	330pF	50V
C549	VG278600	C. CE. TUBLR	330pF	50V
D501	VD631600	DIODE	1SS133, 176, HSS104	
D502	VM975500	DIODE. ZENR	HZS12A2TD 12V	
D503	VD631600	DIODE	1SS133, 176, HSS104	
D504	VM974200	DIODE. ZENR	HZS5C2TD 5.0V	
D507	VD631600	DIODE	1SS133, 176, HSS104	
IC501	XM356A00	IC	NJM2068LD	
* IC502	XN588A00	IC	NJU7313	
IC503	XM356A00	IC	NJM2068LD	
* IC504	XM974A00	IC	BU2040	
IC505	XF494A00	IC	LB1641	
PJ501	VN308700	JACK. PIN	6P	
PJ502	VJ696200	JACK. PIN	4P	
PJ503	VJ696200	JACK. PIN	4P	
Q501	iD043820	TR	2SD438 E F	
Q502	iC287820	TR	2SC2878 A B	
Q503	iC287820	TR	2SC2878 A B	
R545	HV453470	R. CAR. FP	4.7Ω	1/4W
R547	HV455100	R. CAR. FP	100Ω	1/4W
R552	HV455100	R. CAR. FP	100Ω	1/4W
R561	HV454100	R. CAR. FP	10Ω	1/4W
R565	HL315100	R. MTL. OXD	100Ω	1W
R566	HL314100	R. MTL. OXD	10Ω	1W
* VR435100	PLATE	W16		
BB069510	GND. MTL	No. 6951		
VB966900	CN	IMSA-6024		

* New Parts

Schm Ref.	PART NO.	Description		
* VR342400	P. C. B.	EFFECT (UC)		
* VR342500	P. C. B.	EFFECT (RAB)		
* VR342600	P. C. B.	EFFECT (G)		
* VR342900	P. C. B.	EFFECT (UC)		
* CB701	VQ964100	CN. BS. PIN	20P	
* CB702	VR358000	CN. BS. PIN	9P	
* CB801	VR358000	CN. BS. PIN	9P	
* CB802	Vi878500	CN. BS. PIN	7P	
* CB803	VP206500	HOLDER. FUS	(UC)	
* CB805	VP206500	HOLDER. FUS	(UC)	
* CB810	VP206500	HOLDER. FUS	(UC)	
* CB812	VP206500	HOLDER. FUS	(UC)	
* CB813	VK025100	CN. BS. PIN	7P	
* CB814	VR358000	CN. BS. PIN	9P	
* CB815	VP206500	HOLDER. FUS	(RABG)	
* CB816	VP206500	HOLDER. FUS	(RABG)	
* CB817	VP206500	HOLDER. FUS	(RABG)	
* CB818	VP206500	HOLDER. FUS	(RABG)	
C701	UJ667470	C. EL	47uF	50V
C702	UM417100	C. EL	10uF	50V
C703	VF760000	C. EL	100uF	10V
C704	VD930900	C. CE. SMI	0.1uF	25V
C705	UJ648100	C. EL	100uF	25V
C706	VD930900	C. CE. SMI	0.1uF	25V
C707	UJ667470	C. EL	47uF	50V
C708	VD930900	C. CE. SMI	0.1uF	25V
C709	UM417100	C. EL	10uF	50V
C710	VD930900	C. CE. SMI	0.1uF	25V
C711	UJ667470	C. EL	47uF	50V
C712	UA653330	C. MYLAR	3300pF	50V
C713	UA653330	C. MYLAR	3300pF	50V
C714	UJ667470	C. EL	47uF	50V
C715	UJ667470	C. EL	47uF	50V
C716	VJ839200	C. EL	2.2uF	50V
C717	UA654180	C. MYLAR	0.018uF	50V
C718	UA654180	C. MYLAR	0.018uF	50V
C719	VJ839200	C. EL	2.2uF	50V
C720	UM417100	C. EL	10uF	50V
C721	FG212330	C. CE	330pF	50V
C722	UJ667470	C. EL	47uF	50V
C723	FG212330	C. CE	330pF	50V
C724	UJ667470	C. EL	47uF	50V
C725	FG212330	C. CE	330pF	50V
C726	FG212330	C. CE	330pF	50V
C727	UJ667470	C. EL	47uF	50V
C728	VE551900	C. CE	100pF	50V
C729	VE551900	C. CE	100pF	50V
C730	VE551900	C. CE	100pF	50V
C731	VE551900	C. CE	100pF	50V
C732	VE551900	C. CE	100pF	50V
C733	VE551900	C. CE	100pF	50V
C734	VE551900	C. CE	100pF	50V

* New Parts

P. C. B. EFFECT

Schm Ref.	PART NO.	Description
C735	UA653470	C. MYLAR 4700pF 50V
* C736	UA652390	C. MYLAR 390pF 50V
* C737	UA652390	C. MYLAR 390pF 50V
C738	UA653470	C. MYLAR 4700pF 50V
C739	UJ667470	C. EL 47uF 50V
C740	UJ667470	C. EL 47uF 50V
C741	FG211820	C. CE 82pF 50V
C742	UA654680	C. MYLAR 0.068uF 50V
C743	UJ667470	C. EL 47uF 50V
C744	UM407220	C. EL 22uF 25V
C745	UJ667470	C. EL 47uF 50V
C746	UJ667470	C. EL 47uF 50V
C747	VE551900	C. CE 100pF 50V
C748	UJ667470	C. EL 47uF 50V
C749	FG213100	C. CE 1000pF 50V
C750	UM407220	C. EL 22uF 25V
C751	UA653270	C. MYLAR 2700pF 50V
C752	UA653180	C. MYLAR 1800pF 50V
C753	UA653180	C. MYLAR 1800pF 50V
C754	UA653270	C. MYLAR 2700pF 50V
C755	UM407220	C. EL 22uF 25V
C756	FG213100	C. CE 1000pF 50V
C757	UM407220	C. EL 22uF 25V
C758	UM407220	C. EL 22uF 25V
C759	UG444220	C. CE 0.022uF 50V
C760	VJ839200	C. EL 2.2uF 50V
C761	VJ839200	C. EL 2.2uF 50V
C762	UM417100	C. EL 10uF 50V
C763	UM417100	C. EL 10uF 50V
C764	UJ648100	C. EL 100uF 25V
C765	UJ648100	C. EL 100uF 25V
C766	UM417100	C. EL 10uF 50V
C767	UM417100	C. EL 10uF 50V
C768	UA652470	C. MYLAR 470pF 50V
C769	VG290900	C. EL 10uF 50V
C770	VG290900	C. EL 10uF 50V
C771	UA652470	C. MYLAR 470pF 50V
C772	VF466800	C. CE. TUBLR 100pF 50V
C773	VF466800	C. CE. TUBLR 100pF 50V
C774	VF466800	C. CE. TUBLR 100pF 50V
C775	VF466800	C. CE. TUBLR 100pF 50V
C776	VH483900	C. CE. ARRAY 100pF 50V
C777	VP755200	C. CE. ARRAY 100pF 50V
C778	VF466800	C. CE. TUBLR 100pF 50V
C779	VF466800	C. CE. TUBLR 100pF 50V
C780	VF466800	C. CE. TUBLR 100pF 50V
C781	VF466800	C. CE. TUBLR 100pF 50V
C801	FG212220	C. CE 220pF 50V
C802	UM417100	C. EL 10uF 50V
C803	Fi553330	C. CE 3300pF 50V
C804	VE551900	C. CE 100pF 50V
C805	UH178100	C. EL 100uF 63V

* New Parts

Schm Ref.	PART NO.	Description
C806	VJ837200	C. EL 47uF 16V
C807	Ui367220	C. EL 22uF 50V
C808	UM417100	C. EL 10uF 50V
C809	FG212220	C. CE 220pF 50V
C810	VE551900	C. CE 100pF 50V
C811	FG211220	C. CE 22pF 50V
C812	VE551900	C. CE 100pF 50V
C813	UJ667470	C. EL 47uF 50V
C814	UA654470	C. MYLAR 0.047uF 50V
C815	FG212220	C. CE 220pF 50V
C816	VE551900	C. CE 100pF 50V
C817	FG211220	C. CE 22pF 50V
C818	VE551900	C. CE 100pF 50V
C819	UJ667470	C. EL 47uF 50V
C820	UA654470	C. MYLAR 0.047uF 50V
* C821	VR325000	C. MYLAR 100pF 100V
C822	FH611220	C. CE 22pF 500V
C823	VJ839100	C. EL 1uF 50V
C824	Ui367220	C. EL 22uF 50V
* C825	VR325000	C. MYLAR 100pF 100V
△ C826	VG289900	C. EL 2200uF 35V
△ C827	VF964800	C. EL 100uF 16V
△ C828	VG289900	C. EL 2200uF 35V
C829	UG444100	C. CE 0.01uF 50V(G)
C830	UG444220	C. CE 0.022uF 50V(G)
C831	UG413220	C. CE 2200pF 50V(G)
C832	UG444100	C. CE 0.01uF 50V(G)
C833	UG444100	C. CE 0.01uF 50V(G)
C834	UG444100	C. CE 0.01uF 50V(G)
C835	VE117600	C. EL 220uF 10V
C836	VJ839100	C. EL 1uF 50V
* C837	VD916400	C. EL 2.2uF 50V
C838	UA654470	C. MYLAR 0.047uF 50V
△* C839	VR325300	C. MYLAR 0.047uF 100V
△* C840	VR325300	C. MYLAR 0.047uF 100V
C855	VJ836900	C. EL 10uF 16V
C856	VJ837200	C. EL 47uF 16V
C857	VJ836900	C. EL 10uF 16V
C858	VF637900	C. EL 1000uF 10V
C859	VF637900	C. EL 1000uF 10V
C860	VD930900	C. CE. SMI 0.1uF 25V
C861	UJ638470	C. EL 470uF 16V
C862	FG211220	C. CE 22pF 50V
C863	VF637900	C. EL 1000uF 10V
C864	UG413220	C. CE 2200pF 50V(G)
C865	UG413220	C. CE 2200pF 50V(G)
C866	VH053100	C. CE. TUBLR 0.1uF 50V(UC)
C867	VH053100	C. CE. TUBLR 0.1uF 50V(G)
C868	VH053100	C. CE. TUBLR 0.1uF 50V(G)
D701	VD631600	DIODE 1SS133, 176, HSS104
D702	VD631600	DIODE 1SS133, 176, HSS104
D703	VD631600	DIODE 1SS133, 176, HSS104

* New Parts

P. C. B. EFFECT

Schm Ref.	PART NO.	Description
D704	VD631600	DIODE 1SS133, 176, HSS104
D705	VD631600	DIODE 1SS133, 176, HSS104
D706	VD631600	DIODE 1SS133, 176, HSS104
D707	VD631600	DIODE 1SS133, 176, HSS104
D708	VD631600	DIODE 1SS133, 176, HSS104
D709	VD631600	DIODE 1SS133, 176, HSS104
D710	VM975100	DIODE. ZENR HZS9C2TD 9.0V
D711	VM975100	DIODE. ZENR HZS9C2TD 9.0V
* D801	VM976300	DIODE. ZENR HZS242TD 24V
D802	VD631600	DIODE 1SS133, 176, HSS104
D803	VD631600	DIODE 1SS133, 176, HSS104
D804	VN008700	DIODE 1SS270A
D805	VM974100	DIODE. ZENR HZS5B2TD 5.0V
△ D806	VN011300	DIODE. BRG D3SBA20 4A 200V
D807	VD631600	DIODE 1SS133, 176, HSS104
△ F801	KB003620	FUSE T4.0A 125V(UC)
△ F802	KB003620	FUSE T4.0A 125V(UC)
△ F803	KB002980	FUSE T2.5A 250V(RABG)
F804	KB002980	FUSE T2.5A 250V(RABG)
IC701	XA507A00	IC AN78N05
IC702	XK358A00	IC HM65256BLSP-10
IC703	Xi022B00	IC YSS203B-F
IC704	XB247301	IC uPC4570HA
IC705	XC520A01	IC uPC4570C
IC706	XC520A01	IC uPC4570C
IC707	XB247301	IC uPC4570HA
* IC708	XN324A00	IC NJM4558DV
* IC709	XN324A00	IC NJM4558DV
IC710	XC520A01	IC uPC4570C
IC711	XB247301	IC uPC4570HA
IC712	XB247301	IC uPC4570HA
IC713	iG055100	IC TC4053BP
IC714	iG055100	IC TC4053BP
△ IC801	XG505A00	IC NJM79M15FA
△ IC802	iG102700	IC uPC1188H
△ IC803	iG102700	IC uPC1188H
△ IC855	XH436A00	IC LA7956
L701	Vi546100	COIL 220uH
L702	VC362000	COIL 1mH
* L801	VP575600	COIL 1.5uH
* L802	VP575600	COIL 1.5uH
* L803	VP575600	COIL 1.5uH
PJ801	VM750500	JACK. PIN 4P
Q701	VG722000	TR. DGT DTC144ES
Q702	VD678500	TR. DGT DTA114ES
Q703	VD678500	TR. DGT DTA114ES
Q704	VG722000	TR. DGT DTC144ES
Q705	VG722000	TR. DGT DTC144ES
Q801	VC218900	TR 2SC3330 R, S, T
Q802	VC218900	TR 2SC3330 R, S, T
△* Q803	VP872700	TR 2SC4488 S, T
△* Q804	VP872600	TR 2SA1708 S, T

* New Parts

Schm Ref.	PART NO.	Description
△ Q805A	iX615750	TR 2SA1694 O, P, Y(RABG)
△ Q805C	iX615760	TR 2SC4467 O, P, Y(RABG)
△ Q805A	iX630850	TR 2SA1695 O, P, Y(UC)
△ Q805C	iX630860	TR 2SC4468 O, P, Y(UC)
△ Q806	iC1815C0	TR 2SC1815 Y
* Q807	VP883000	TR 2SA893A D, E
Q809	iA093320	TR 2SA933S Q, R
Q810	iC174020	TR 2SC1740S R, S
* Q811	VP883000	TR 2SA893A D, E
* Q812	VP882900	TR 2SC1890 E
Q855	iA101521	TR 2SA1015 Y
Q856	iC1815C0	TR 2SC1815 Y
Q857	iC287820	TR 2SC2878 A, B
Q858	iC287820	TR 2SC2878 A, B
Q859	iC287820	TR 2SC2878 A, B
R701	HL314680	R. MTL. OXD 68Ω 1W
R781	HV454220	R. CAR. FP 22Ω 1/4W
R782	HV454220	R. CAR. FP 22Ω 1/4W
R783	HV456100	R. CAR. FP 1KΩ 1/4W
R784	HV456100	R. CAR. FP 1KΩ 1/4W
R811	HV453470	R. CAR. FP 4.7Ω 1/4W
R813	HV454100	R. CAR. FP 10Ω 1/4W
R817	HV453470	R. CAR. FP 4.7Ω 1/4W
R819	HV454100	R. CAR. FP 10Ω 1/4W
△ R822	VK188600	R. FUS 470Ω 1/4W
R823	HV454100	R. CAR. FP 10Ω 1/4W
R824	HV453470	R. CAR. FP 4.7Ω 1/4W
R825	HV456270	R. CAR. FP 2.7KΩ 1/4W
R826	VK188600	R. FUS 470Ω 1/4W
△* R828	HZ003780	R. MTL. PLAT 0.22Ω+0.22 5W
R829	HV456150	R. CAR. FP 1.5KΩ 1/4W
R830	HV453470	R. CAR. FP 4.7Ω 1/4W
R831	HV456820	R. CAR. FP 8.2KΩ 1/4W
R835	HV453220	R. CAR. FP 2.2Ω 1/4W(G)
! R838	HV453470	R. CAR. FP 4.7Ω 1/4W
% R838	HV454100	R. CAR. FP 10Ω 1/4W
! R839	HL326100	R. MTL. OXD 1KΩ 2W
% R839	HL425820	R. MTL. OXD 820Ω 2W
△ R843	HV457100	R. CAR. FP 10KΩ 1/4W
△ R847	HV454100	R. CAR. FP 10Ω 1/4W
R850	HV453220	R. CAR. FP 2.2Ω 1/4W
R859	HV454470	R. CAR. FP 47Ω 1/4W
R871	HV453220	R. CAR. FP 2.2Ω 1/4W(G)
R872	HV453220	R. CAR. FP 2.2Ω 1/4W(G)
△ RY801	VK913100	RELAY DC G5Z-2A
TE801	VN937900	TERM. SP 6P
* VR701	VR043900	VR A10KΩ
* VR702	VR058000	VR A10KΩ
* W858	VR413300	CN. FLAT 9P 150mm
XL701	VK175200	RSNR. CE 11.28MHz
	VJ828000	PIN IMSA-6024-03E

* New Parts

Note) ! : R-V98
% : RX-V480

1 ■ EXPLODED VIEW

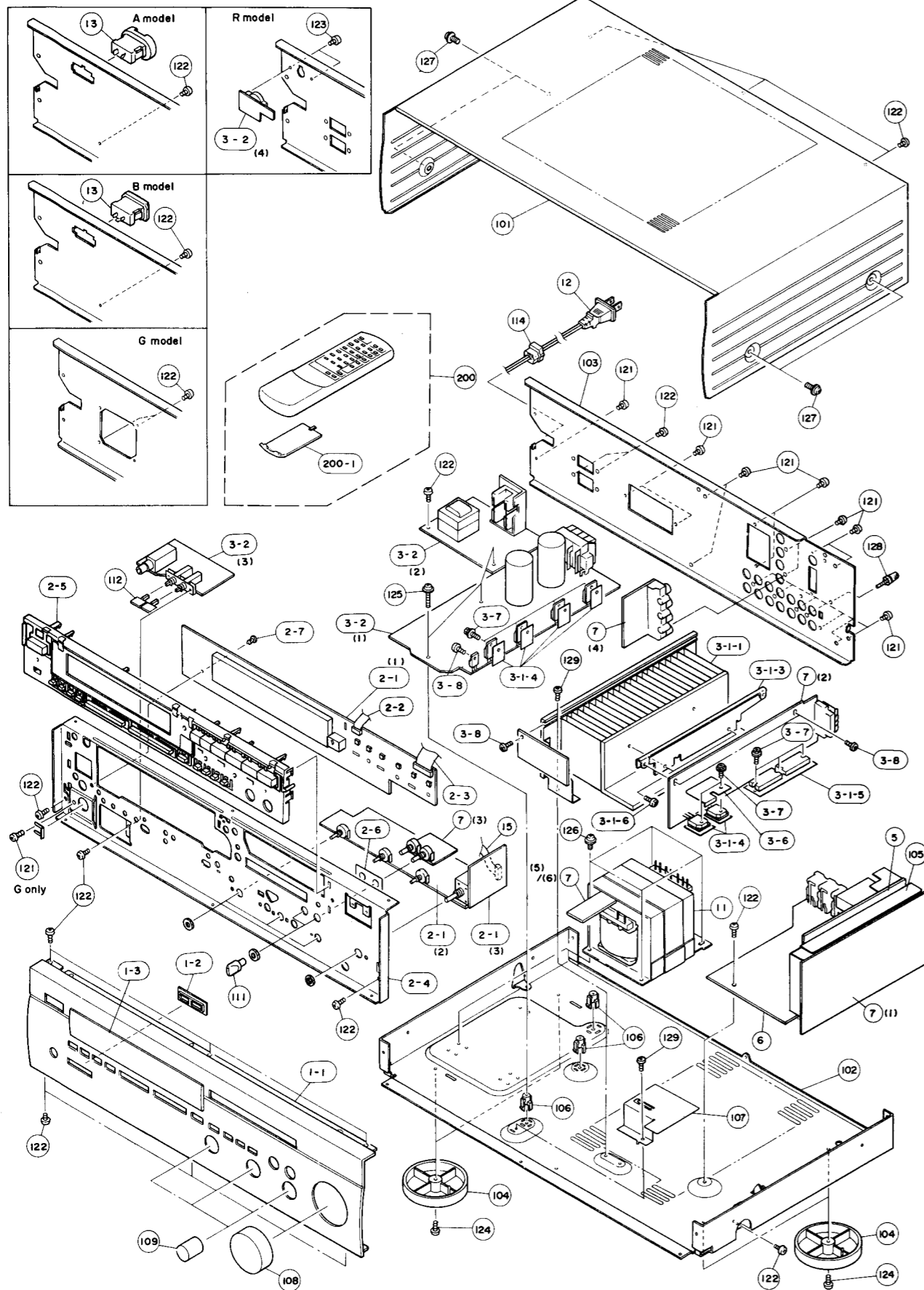

■ MECHANICAL PARTS

Ref. No.	PART NO.	Description	Remarks	Markets
* 1- 1	VQ792700	FRONT PANEL		RX-V480
* 1- 1	VQ792900	FRONT PANEL		R-V98
* 1- 2	VQ793400	BUTTON GUIDE		
* 1- 3	VR010600	WINDOW PANEL		(UCRAB)
* 1- 3	VR010700	WINDOW PANEL		(G)
* 2- 1	VR341400	P. C. B. ASS'Y, OPERATION		(UC)
* 2- 1	VR341500	P. C. B. ASS'Y, OPERATION		(R)
* 2- 1	VR341600	P. C. B. ASS'Y, OPERATION		(AB)
* 2- 1	VR341700	P. C. B. ASS'Y, OPERATION		(G)
* 2- 2	VR413500	CONNECTOR, FLAT CABLE	9P 200mm	
* 2- 3	VR413600	CONNECTOR, FLAT CABLE	19P 200mm	
* 2- 4	VQ864300	SUB CHASSIS		
* 2- 5	VQ794900	CASE, BUTTON		
* 2- 6	VR760300	SHEET, VR	P3555-B	
* 2- 7	VQ368600	PUSH RIVET		
* 3-1-1	VQ967600	HEAT SINK ASS'Y		
* 3-1-3	VQ796100	SUPPORT, PCB		
3-1-4	VK195900	SHEET, RADIATION	19x24	
3-1-5	VR859200	SHEET, RADIATION		
3-1-6	Ei330086	BIND HEAD B-TITE SCREW	3x8 FCRM3-BL	
* 3-2	VR341000	P. C. B. ASS'Y, MAIN		RX-V480 (U)
* 3-2	VR341100	P. C. B. ASS'Y, MAIN		RX-V480 (R)
* 3-2	VR341200	P. C. B. ASS'Y, MAIN		RX-V480 (AB)
* 3-2	VR341300	P. C. B. ASS'Y, MAIN		RX-V480 (G)
* 3-2	VR342700	P. C. B. ASS'Y, MAIN		R-V98 (UC)
* 3-2	VR369700	P. C. B. ASS'Y, MAIN		RX-V480 (C)
* 3-6	VR724200	SUPPORT, TR		
3-7	VK173200	SCREW, TRANSISTOR	3x15 SP FCM3	
3-8	Ei330086	BIND HEAD B-TITE SCREW	3x8 FCRM3-BL	
* 5	VR341800	P. C. B. ASS'Y, TUNER		(UC)
* 5	VR341900	P. C. B. ASS'Y, TUNER		(R)
* 5	VR342000	P. C. B. ASS'Y, TUNER		(AB)
* 5	VR342100	P. C. B. ASS'Y, TUNER		(G)
* 6	VR342200	P. C. B. ASS'Y, INPUT		(UCRAB)
* 6	VR342300	P. C. B. ASS'Y, INPUT		(G)
* 7	VR342400	P. C. B. ASS'Y, EFFECT		RX-V480 (UC)
* 7	VR342500	P. C. B. ASS'Y, EFFECT		RX-V480 (RAB)
* 7	VR342600	P. C. B. ASS'Y, EFFECT		RX-V480 (G)
* 7	VR342900	P. C. B. ASS'Y, EFFECT		R-V98 (UC)
△ * 11	XN571B00	POWER TRANSFORMER		RX-V480 (U)
△ * 11	XN572B00	POWER TRANSFORMER		RX-V480 (C)
△ * 11	XN573B00	POWER TRANSFORMER		RX-V480 (R)
△ * 11	XN574B00	POWER TRANSFORMER		RX-V480 (AB)
△ * 11	XN575B00	POWER TRANSFORMER		RX-V480 (G)
△ * 11	XN576A00	POWER TRANSFORMER		R-V98 (U)
△ * 11	XN577A00	POWER TRANSFORMER		R-V98 (C)
△ * 12	VN804500	POWER CORD ASS'Y		(B)
△ * 12	VQ508400	POWER CORD ASS'Y		(UC)
△ * 12	VQ508500	POWER CORD ASS'Y		(R)
△ * 12	VQ508600	POWER CORD ASS'Y		(A)
△ * 12	VQ508700	POWER CORD ASS'Y		(G)
△ 13	VJ775000	AC OUTLET	2P	(B)
△ 13	VP418700	AC OUTLET	2P	(A)

* New Parts

Ref. No.	PART NO.	Description	Remarks	Markets
* 15	VR413400	CONNECTOR, FLAT CABLE	9P 130mm	
* 101	VQ793800	TOP COVER		
* 102	VQ794000	CHASSIS		
* 103	VQ797400	REAR PANEL		RX-V480 (U)
* 103	VQ797500	REAR PANEL		RX-V480 (C)
* 103	VQ797600	REAR PANEL		RX-V480 (R)
* 103	VQ797700	REAR PANEL		RX-V480 (AB)
* 103	VQ797800	REAR PANEL		RX-V480 (G)
* 103	VQ797900	REAR PANEL		R-V98 (U)
* 103	VQ798000	REAR PANEL		R-V98 (C)
* 104	VQ780300	LEG	D60xH16	RX-V480
* 104	VQ982800	LEG	D60xH16	R-V98
* 105	VQ796200	SHIELD PLATE	DSP	
* 106	VR264400	SPACER, H8		
* 107	VR435000	SHIELD PLATE	MAIN	
* 108	VQ795100	KNOB	φ 42	VOLUME
* 109	VQ779200	KNOB	φ 16	BASS, TREBLE, BAL
* 111	VR308400	KNOB, VR	φ 10	CENTER, REAR
* 112	VQ779000	BUTTON	3x14	SPEAKERS
114	VN158600	CORD STOPPER	No. 2104	
121	EN301010	BIND HEAD BONDING TAP. SCREW	3x8 FCRM3-BL	
122	Ei330086	BIND HEAD B-TITE SCREW	3x8 FCRM3-BL	
123	ED330066	BIND HEAD SCREW	3x6 FCRM3-BL	
124	EK930010	BW HEAD TAPPING SCREW	3x8-8 FCRM3-BL	
125	EL300480	BW HEAD B-TITE SCREW	3x15-8 FCRM3-BL	
126	EK365020	BW HEAD SCREW	4x6 FCRM3-BL	
127	EL300470	BW HEAD S-TITE SCREW	4x8-10 FCRM3-BL	
128	AA627310	GROUND TERMINAL		
129	Ei030046	BIND HEAD TAPPING SCREW	3x4 ZMC2-Y	
		ACCESSORIES		
* 200	VR094100	REMOTE CONTROL TRANSMITTER		
200-1	CX675300	LID	70x31BLSMK	103RRS-028-01MR
* 200-1	VQ147100	ANTENNA, FM	1P 1.4m	
* 200-1	VR248500	AM LOOP ANTENNA	1P 1.0m	
* 200-1	VE364900	ANTENNA ADAPTER	PAL 75-300 Ω	
* 200-1	VP554900	BATTERY, MANGANESE	SUM-3, AA, R06	
* 200-1	VP554900	PAL SOCKET ASS'Y		(B)

* New Parts

RX-V480/R-V98

REMOTE CONTROL TRANSMITTER

■ SCHEMATIC DIAGRAM

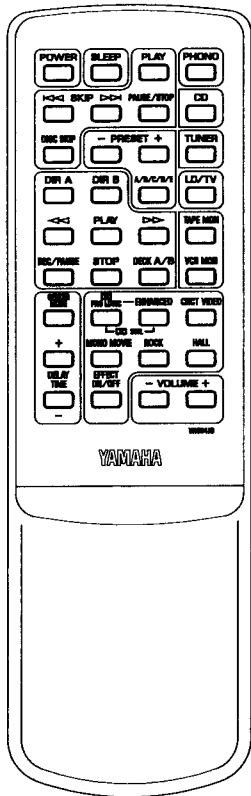
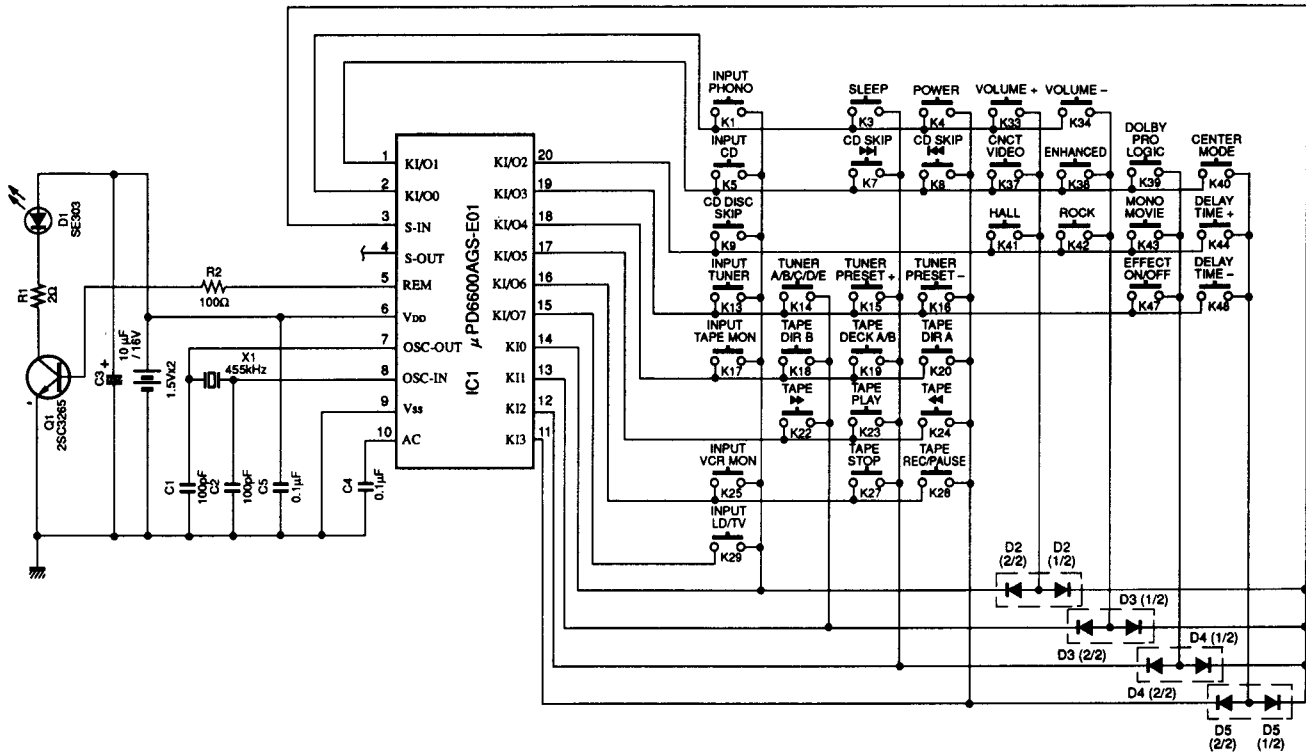

Key No.	Function	HEX	
		CUSTOM	DATA
1	INPUT PHONO	7A	14
3	SLEEP	7A	57
4	POWER	7A	1F
5	INPUT CD	7A	15
7	CD SKIP ►►	7A	0A
8	CD SKIP ◄◄	7A	0B
9	CD DISC SKIP	7A	4F
13	INPUT TUNER	7A	16
14	TUNER A/B/C/D/E	7A	12
15	TUNER PRESET +	7A	10
16	TUNER PRESET -	7A	11
17	INPUT TAPE MON	7A	18
18	TAPE DIR B	7A	40
19	TAPE DECK A/B	7A	06
20	TAPE DIR A	7A	07
22	TAPE ►►	7A	01
23	TAPE PLAY	7A	00
24	TAPE ◄◄	7A	01
25	INPUT VCR MON	7A	0F
27	TAPE STOP	7A	03
28	TAPE REC/PAUSE	7A	04
29	INPUT LD/TV	7A	17
33	VOLUME +	7A	1A
34	VOLUME -	7A	1B
37	CNCT VIDEO	7A	8A
38	ENHANCED	7A	89
39	DOLBY PRO LOGIC	7A	88
40	CENTER MODE	7A	84
41	HALL	7A	8D
42	ROCK	7A	8C
43	MONO MOVIE	7A	8B
44	DELAY TIME +	7A	52
47	EFFECT ON/OFF	7A	56
48	DELAY TIME -	7A	53

Parts List for Carbon Resistors

Value	1/4W Type Part No.	1/6W Type Part No.	Value	1/4W Type Part No.	1/6W Type Part No.
1.0 Ω	HJ35 3100	HF85 3100	10 kΩ	HF45 7100	HF45 7100
1.8 Ω	HJ35 3180	*	11 kΩ	HF45 7110	HF45 7110
2.2 Ω	HJ35 3220	HF85 3220	12 kΩ	HJ35 7120	HF85 7120
3.3 Ω	HJ35 3330	HF85 3330	13 kΩ	HF45 7130	HF45 7130
4.7 Ω	HJ35 3470	HF85 3470	15 kΩ	HF45 7150	HF45 7150
5.6 Ω	HJ35 3560	HF85 3560	18 kΩ	HF45 7180	HF45 7180
10 Ω	HF45 4100	HF45 4100	22 kΩ	HF45 7220	HF45 7220
15 Ω	HJ35 4150	HF85 4150	24 kΩ	HF45 7240	HF45 7240
22 Ω	HF45 4220	HF45 4220	27 kΩ	HJ35 7270	HF85 7270
27 Ω	HJ35 4270	HF85 4270	30 kΩ	HF45 7300	HF45 7300
33 Ω	HF45 4330	HF45 4330	33 kΩ	HF45 7330	HF45 7330
39 Ω	HJ35 4470	HF85 4390	36 kΩ	HF45 7360	HF45 7360
47 Ω	HF45 4470	HF45 4470	39 kΩ	HF45 7390	HF45 7390
56 Ω	HF45 4560	HF45 4560	47 kΩ	HF45 7470	HF45 7470
68 Ω	HF45 4680	HF45 4680	51 kΩ	HF45 7510	HF45 7510
75 Ω	HF45 4750	HF45 4750	56 kΩ	HF45 7560	HF45 7560
82 Ω	HF45 4820	HF45 4820	62 kΩ	HF45 7620	HF45 7620
91 Ω	HF45 4910	HF45 4910	68 kΩ	HF45 7680	HF45 7680
100 Ω	HF45 5100	HF45 5100	82 kΩ	HF45 7820	HF45 7820
110 Ω	HJ35 5110	HF85 5110	91 kΩ	HF45 7910	HF45 7910
120 Ω	HF45 5120	HF45 5120	100 kΩ	HF45 8100	HF45 8100
150 Ω	HF45 5150	HF45 5150	110 kΩ	HF45 8110	HF45 8110
160 Ω	HJ35 5160	*	120 kΩ	HF45 8120	HF45 8120
180 Ω	HF45 5180	HF45 5180	150 kΩ	HF45 8150	HF45 8150
200 Ω	HF45 5200	HF45 5200	180 kΩ	HF45 8180	HF45 8180
220 Ω	HF45 5220	HF45 5220	220 kΩ	HJ35 8220	HF85 8220
270 Ω	HF45 5270	HF45 5270	270 kΩ	HF45 8270	HF45 8270
330 Ω	HF45 5330	HF45 5330	300 kΩ	HF45 8300	HF45 8300
390 Ω	HF45 5390	HF45 5390	330 kΩ	HF45 8330	HF45 8330
430 Ω	HF45 5430	HF45 5430	390 kΩ	HJ35 8390	HF85 8390
470 Ω	HF45 5470	HF45 5470	470 kΩ	HF45 8470	HF45 8470
510 Ω	HF45 5510	HF45 5510	560 kΩ	HJ35 8560	HF85 8560
560 Ω	HF45 5560	HF45 5560	680 kΩ	HJ35 8680	HF85 8680
680 Ω	HF45 5680	HF45 5680	820 kΩ	HJ35 8820	HF85 8820
820 Ω	HF45 5820	HF45 5820	1.0 MΩ	HF45 9100	HF45 9100
910 Ω	HF45 5910	HF45 5910	1.2 MΩ	HJ35 9120	*
1.0 kΩ	HF45 6100	HF45 6100	1.5 MΩ	HJ35 9150	HF85 9150
1.2 kΩ	HF45 6120	HF45 6120	1.8 MΩ	HJ35 9180	HF85 9180
1.5 kΩ	HF45 6150	HF45 6150	2.2 MΩ	HJ35 9220	HF85 9220
1.8 kΩ	HF45 6180	HF45 6180	3.3 MΩ	HJ35 9330	HF85 9330
2.0 kΩ	HJ35 6200	HF85 6200	3.9 MΩ	HJ35 9390	*
2.2 kΩ	HF45 6220	HF45 6220	4.7 MΩ	HJ35 9470	HF85 9470
2.4 kΩ	HJ35 6240	HF85 6240			
2.7 kΩ	HF45 6270	HF45 6270			
3.0 kΩ	HF45 6300	HF45 6300			
3.3 kΩ	HF45 6330	HF45 6330			
3.6 kΩ	HJ35 6360	HF85 6360			
3.9 kΩ	HF45 6390	HF45 6390			
4.7 kΩ	HF45 6470	HF45 6470			
5.1 kΩ	HF45 6510	HF45 6510			
5.6 kΩ	HF45 6560	HF45 6560			
6.8 kΩ	HF45 6680	HF45 6680			
8.2 kΩ	HF45 6820	HF45 6820			
9.1 kΩ	HF45 6910	HF45 6910			

1/4W Type

HJ35 ○○○○
10mm

1/6W Type

HF85 ○○○○
5mm

RX-V480/R-V98

YAMAHA