

# **SXS** REFRIGERATOR

## **SERVICE MANUAL**

### **CAUTION**

**PLEASE READ CAREFULLY THE SAFETY PRECAUTIONS OF THIS BOOK  
BEFORE CHECKING OR OPERATING THE REFRIGERATOR.**

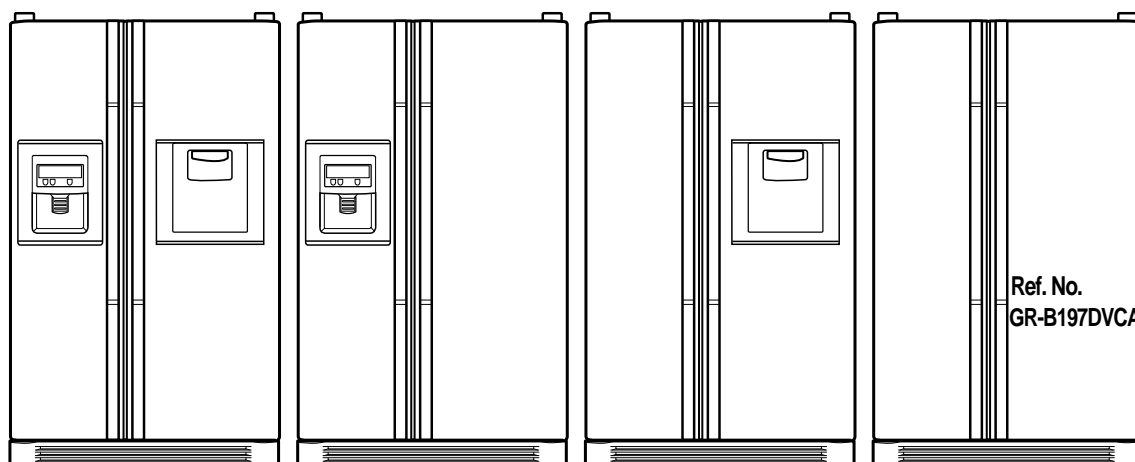

**MODEL: GR-B197WV**

**COLOR: SUPER WHITE**

# CONTENTS

---

<b>WARNINGS AND PRECAUTIONS FOR SAFETY .....</b>	<b>3</b>
<b>SPECIFICATIONS.....</b>	<b>4</b>
<b>PARTS IDENTIFICATION .....</b>	<b>12</b>
<b>HOW TO INSTALL THE REFRIGERATOR .....</b>	<b>18</b>
HOW TO ADJUST DOOR HEIGHT OF THE REFRIGERATOR .....	18
HOW TO INSTALL WATER PIPE.....	19
HOW TO CONTROL THE AMOUNT OF WATER SUPPLIED TO THE ICEMAKER .....	23
<b>MICOM FUNCTION .....</b>	<b>25</b>
<b>MICOM CIRCUIT DESCRIPTION.....</b>	<b>31</b>
DESCRIPTION OF PWB CIRCUIT	
SENSOR RESISTANCE CHARACTERISTIC TABIE	
PWB PARTS DRAWING AND LIST	
PWB CIRCUIT DRAWING	
<b>ICE MAKER AND DISPENSER WORKING PRINCIPLES AND REPAIR .....</b>	<b>53</b>
WORKING PRINCIPLES	
FUNCTION OF ICE MAKER	
ICE MAKER TROUBLESHOOTING	
ICE MAKER CIRCUITS	
<b>CIRCUIT .....</b>	<b>58</b>
<b>TROUBLE DIAGNOSIS.....</b>	<b>60</b>
TROUBLE SHOOTING .....	60
FAULTS .....	70
COOLING CYCLE HEAVY REPAIR .....	87
HOW TO DEAL WITH CLAIMS .....	94
<b>HOW TO DISASSEMBLE AND ASSEMBLE .....</b>	<b>99</b>
DOOR.....	99
HANDLE .....	100
SHROUD, GRILLE FAN .....	100
ICEMAKER.....	100
DISPENSER.....	101
WATER TANK AND WATER LINE.....	103
HOME BAR .....	103
<b>EXPLODED VIEW .....</b>	<b>104</b>
<b>REPLACEMENT PARTS LIST.....</b>	<b>113</b>

# WARNINGS AND PRECAUTIONS FOR SAFETY

---

Please observe the following safety precautions in order to use safely and correctly the refrigerator and to prevent accident and danger during repair.

1. Be care of an electric shock. Disconnect power cord from wall outlet and wait for more than three minutes before replacing PWB parts. Shut off the power whenever replacing and repairing electric components.
2. When connecting power cord, please wait for more than five minutes after power cord was disconnected from the wall outlet.
3. Please check if the power plug is pressed down by the refrigerator against the wall. If the power plug was damaged, it may cause fire or electric shock.
4. If the wall outlet is over loaded, it may cause fire. Please use its own individual electrical outlet for the refrigerator.
5. Please make sure the outlet is properly earthed, particularly in wet or damp area.
6. Use standard electrical components when replacing them.
7. Make sure the hook is correctly engaged.  
Remove dust and foreign materials from the housing and connecting parts.
8. Do not fray, damage, machine, heavily bend, pull out, or twist the power cord.
9. Please check the evidence of moisture intrusion in the electrical components. Replace the parts or mask it with insulation tapes if moisture intrusion was confirmed.
10. Do not touch the icemaker with hands or tools to confirm the operation of geared motor.
11. Do not let the customers repair, disassemble, and reconstruct the refrigerator for themselves. It may cause accident, electric shock, or fire.
12. Do not store flammable materials such as ether, benzene, alcohol, chemicals, gas, or medicine in the refrigerator.
13. Do not put flower vase, cup, cosmetics, chemicals, etc., or container with full of water on the top of the refrigerator.
14. Do not put glass bottles with full of water into the freezer. The contents shall freeze and break the glass bottles.
15. When you scrap the refrigerator, please disconnect the door gasket first and scrap it where children are not accessible.

# SPECIFICATIONS

## 1. Ref No. : GR-P247

ITEMS	SPECIFICATIONS	ITEMS	SPECIFICATIONS
DIMENSIONS (mm)	890(W)×840(D)×1750(H)	FIRST DEFROST	4 - 5 Hours
NET WEIGHT (kg)	128	DEFROST CYCLE	13 - 15 Hours
COOLING SYSTEM	Fan Cooling	DEFROSTING DEVICE	Heater, Sheath
TEMPERATURE CONTROL	Micom Control		Heater, L - Cord
DEFROSTING SYSTEM	Full Automatic	ANTI SWEAT HEATER	Dispenser Duct Door Heater
	Heater Defrost		Dispenser Heater
INSULATION	Cyclo-Pentane		Home Bar Heater
COMPRESSOR	P.T.C. Starting Type	ANTI-FREEZING HEATER	Water Tank Heater
EVAPORATOR	Fin Tube Type		Damper Heater
CONDENSER	Wire Condenser	FREEZER LAMP	40W (1 EA)
REFRIGERANT	R134a (185g)	REFRIGERATOR LAMP	40W (1 EA)
LUBRICATING OIL	FREOL @15G (320 cc)	DISPENSER LAMP	15W (1 EA)
DRIER	1Ø0.83		
CAPILLARY TUBE	MOLECULAR SIEVE XH-7		

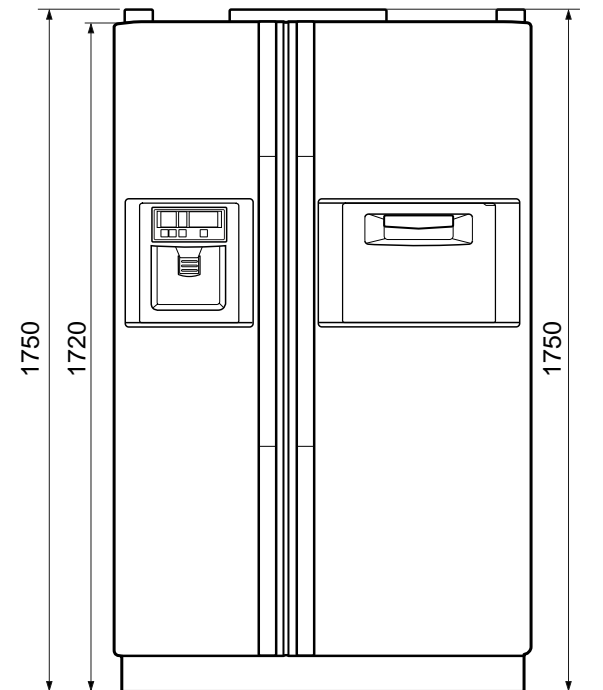

<Front View>

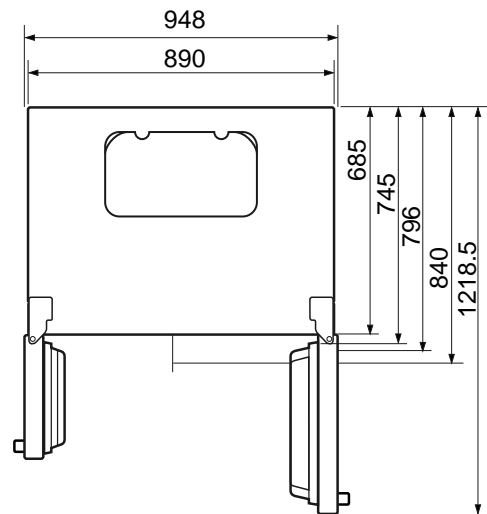

<Plane View>

# SPECIFICATIONS

## 2. Ref No. : GR-P207

ITEMS	SPECIFICATIONS	ITEMS	SPECIFICATIONS
DIMENSIONS (mm)	890(W)×755(D)×1750(H)	FIRST DEFROST	4 - 5 Hours
NET WEIGHT (kg)	123	DEFROST CYCLE	13 - 15 Hours
COOLING SYSTEM	Fan Cooling	DEFROSTING DEVICE	Heater, Sheath
TEMPERATURE CONTROL	Micom Control		Heater, L - Cord
DEFROSTING SYSTEM	Full Automatic	ANTI SWEAT HEATER	Dispenser Duct Door Heater
	Heater Defrost		Dispenser Heater
INSULATION	Cyclo-Pentane		Home Bar Heater
COMPRESSOR	P.T.C. Starting Type	ANTI-FREEZING HEATER	Water Tank Heater
EVAPORATOR	Fin Tube Type		Damper Heater
CONDENSER	Wire Condenser	FREEZER LAMP	40W (1 EA)
REFRIGERANT	R134a (185g)	REFRIGERATOR LAMP	40W (1 EA)
LUBRICATING OIL	FREOL @15G (320 cc)	DISPENSER LAMP	15W (1 EA)
DRIER	1Ø0.83		
CAPILLARY TUBE	MOLECULAR SIEVE XH-7		

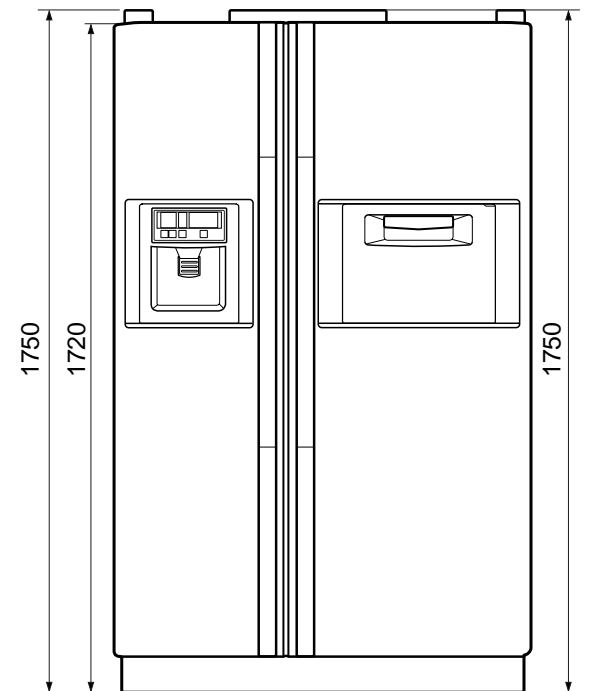

<Front View>

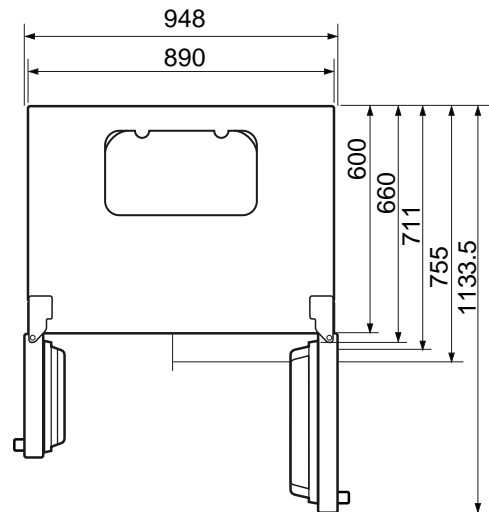

<Plane View>

# SPECIFICATIONS

## 3. Ref No. : GR-L247

ITEMS	SPECIFICATIONS	ITEMS	SPECIFICATIONS
DIMENSIONS (mm)	890(W)x840(D)x1750(H)	CAPILLARY TUBE	MOLECULAR SIEVE XH-7
NET WEIGHT (kg)	125	FIRST DEFROST	4 - 5 Hours
COOLING SYSTEM	Fan Cooling	DEFROST CYCLE	13 - 15 Hours
TEMPERATURE CONTROL	Micom Control	DEFROSTING DEVICE	Heater, Sheath
DEFROSTING SYSTEM	Full Automatic		Heater, L-Cord
	Heater Defrost	ANTI SWEAT HEATER	Dispenser Duct Door Heater
INSULATION	Cyclo-Pentane		Dispenser Heater
COMPRESSOR	P.T.C. Starting Type	ANTI-FREEZING HEATER	Water Tank Heater
EVAPORATOR	Fin Tube Type		Damper Heater
CONDENSER	Wire Condenser	FREEZER LAMP	40W (1 EA)
REFRIGERANT	R134a (185g)	REFRIGERATOR LAMP	40W (1 EA)
LUBRICATING OIL	FREOL @15G (320 cc)	DISPENSER LAMP	15W (1 EA)
DRIER	1Ø0.83		

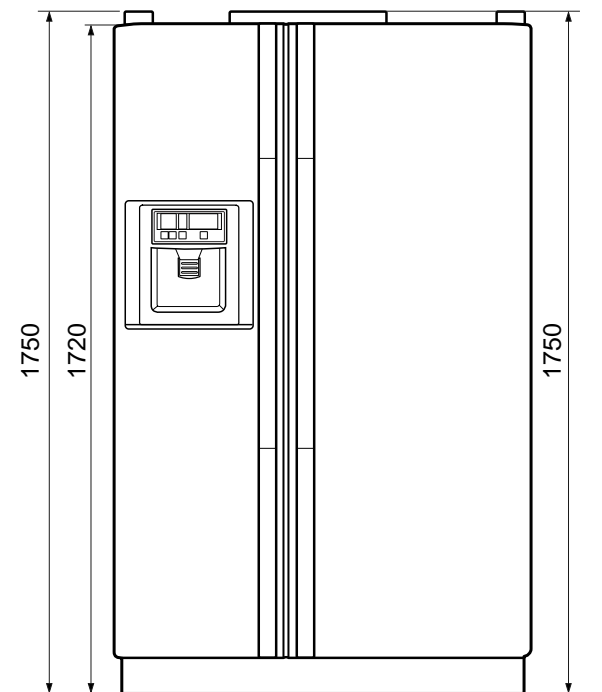

<Front View>

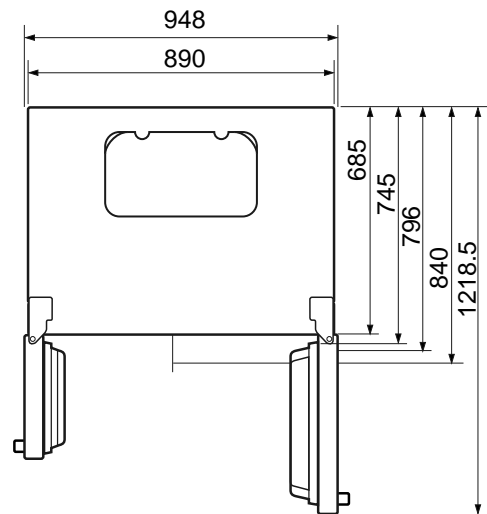

<Plane View>

# SPECIFICATIONS

## 4. Ref No. : GR-L207

ITEMS	SPECIFICATIONS	ITEMS	SPECIFICATIONS
DIMENSIONS (mm)	890(W)×755(D)×1750(H)	CAPILLARY TUBE	MOLECULAR SIEVE XH-7
NET WEIGHT (kg)	120	FIRST DEFROST	4 - 5 Hours
COOLING SYSTEM	Fan Cooling	DEFROST CYCLE	13 - 15 Hours
TEMPERATURE CONTROL	Micom Control	DEFROSTING DEVICE	Heater, Sheath
DEFROSTING SYSTEM	Full Automatic		Heater, L-Cord
	Heater Defrost	ANTI SWEAT HEATER	Dispenser Duct Door Heater
INSULATION	Cyclo-Pentane		Dispenser Heater
COMPRESSOR	P.T.C. Starting Type	ANTI-FREEZING HEATER	Water Tank Heater
EVAPORATOR	Fin Tube Type		Damper Heater
CONDENSER	Wire Condenser	FREEZER LAMP	40W (1 EA)
REFRIGERANT	R134a (185g)	REFRIGERATOR LAMP	40W (1 EA)
LUBRICATING OIL	FREOL @15G (320 cc)	DISPENSER LAMP	15W (1 EA)
DRIER	1Ø0.83		

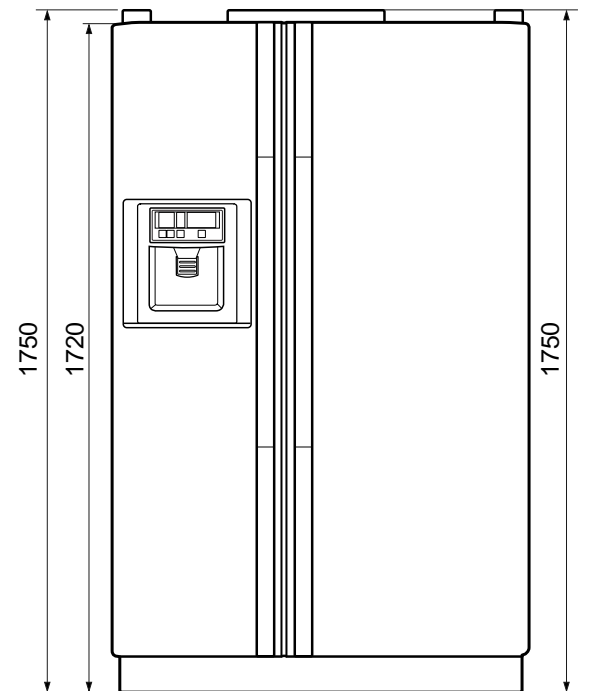

<Front View>

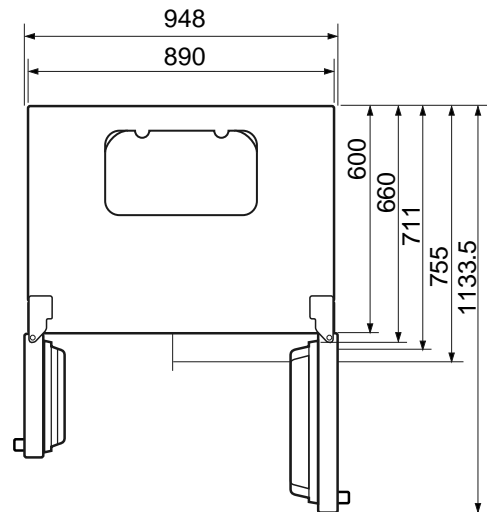

<Plane View>

# SPECIFICATIONS

## 1. Ref No. : GR-C247

ITEMS	SPECIFICATIONS	ITEMS	SPECIFICATIONS
DIMENSIONS (mm)	890(W)x840(D)x1750(H)	FIRST DEFROST	4 - 5 Hours
NET WEIGHT (kg)	117	DEFROST CYCLE	13 - 15 Hours
COOLING SYSTEM	Fan Cooling	DEFROSTING DEVICE	Heater, Sheath
TEMPERATURE CONTROL	Micom Control		Heater, L - Cord
DEFROSTING SYSTEM	Full Automatic	ANTI SWEAT HEATER	Home Bar Heater
	Heater Defrost	ANTI-FREEZING HEATER	Damper Heater
INSULATION	Cyclo-Pentane	FREEZER LAMP	40W (1 EA)
COMPRESSOR	P.T.C. Starting Type	REFRIGERATOR LAMP	40W (1 EA)
EVAPORATOR	Fin Tube Type	DISPENSER LAMP	15W (1 EA)
CONDENSER	Wire Condenser		
REFRIGERANT	R134a (185g)		
LUBRICATING OIL	FREOL @15G (320 cc)		
DRIER	1Ø0.83		
CAPILLARY TUBE	MOLECULAR SIEVE XH-7		

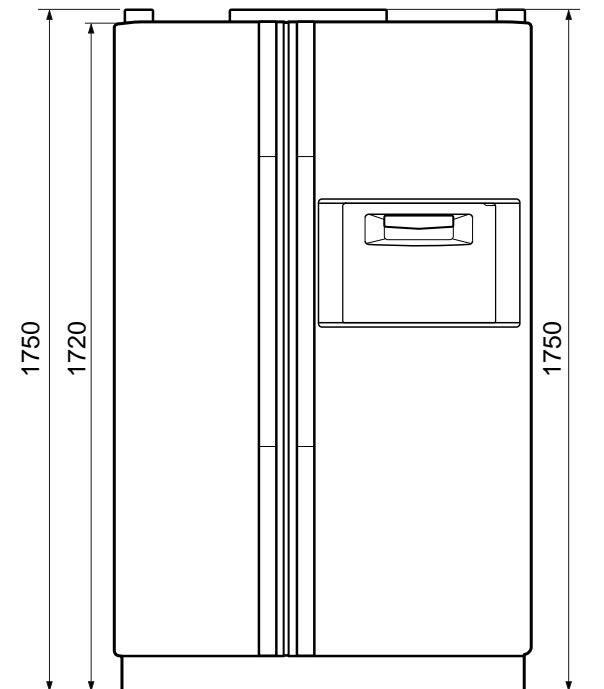

<Front View>

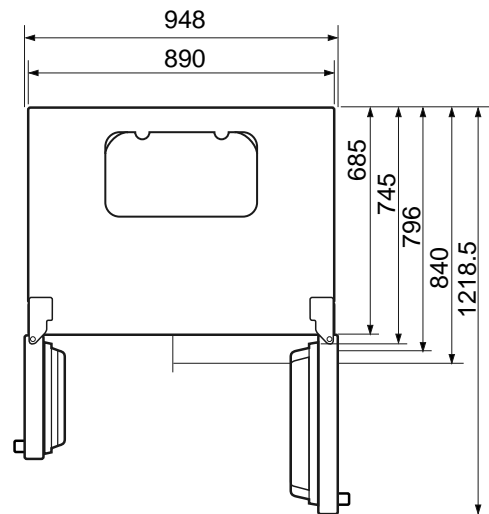

<Plane View>



# SPECIFICATIONS

## 2. Ref No. : GR-C207

ITEMS	SPECIFICATIONS	ITEMS	SPECIFICATIONS
DIMENSIONS (mm)	890(W)×755(D)×1750(H)	FIRST DEFROST	4 - 5 Hours
NET WEIGHT (kg)	112	DEFROST CYCLE	13 - 15 Hours
COOLING SYSTEM	Fan Cooling	DEFROSTING DEVICE	Heater, Sheath
TEMPERATURE CONTROL	Micom Control		Heater, L - Cord
DEFROSTING SYSTEM	Full Automatic	ANTI SWEAT HEATER	Home Bar Heater
	Heater Defrost	ANTI-FREEZING HEATER	Damper Heater
INSULATION	Cyclo-Pentane	FREEZER LAMP	40W (1 EA)
COMPRESSOR	P.T.C. Starting Type	REFRIGERATOR LAMP	40W (1 EA)
EVAPORATOR	Fin Tube Type	DISPENSER LAMP	15W (1 EA)
CONDENSER	Wire Condenser		
REFRIGERANT	R134a (185g)		
LUBRICATING OIL	FREOL @15G (320 cc)		
DRIER	1Ø0.83		
CAPILLARY TUBE	MOLECULAR SIEVE XH-7		

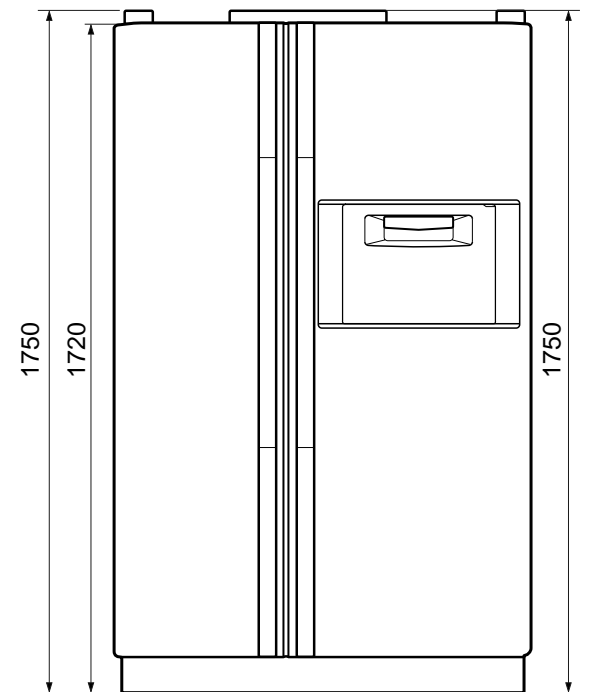

<Front View>

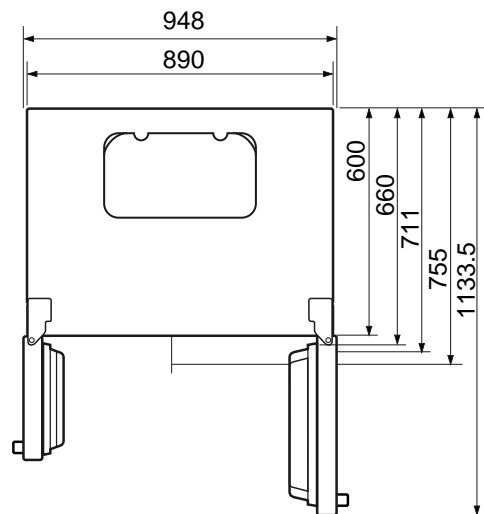

<Plane View>

# SPECIFICATIONS

## 3. Ref No. : GR-B247

ITEMS	SPECIFICATIONS	ITEMS	SPECIFICATIONS
DIMENSIONS (mm)	890(W)×840(D)×1750(H)	CAPILLARY TUBE	MOLECULAR SIEVE XH-7
NET WEIGHT (kg)	114	FIRST DEFROST	4 - 5 Hours
COOLING SYSTEM	Fan Cooling	DEFROST CYCLE	13 - 15 Hours
TEMPERATURE CONTROL	Micom Control	DEFROSTING DEVICE	Heater, Sheath
DEFROSTING SYSTEM	Full Automatic		Heater, L-Cord
	Heater Defrost	ANTI-FREEZING HEATER	Damper Heater
INSULATION	Cyclo-Pentane	FREEZER LAMP	40W (1 EA)
COMPRESSOR	P.T.C. Starting Type	REFRIGERATOR LAMP	40W (1 EA)
EVAPORATOR	Fin Tube Type	DISPENSER LAMP	15W (1 EA)
CONDENSER	Wire Condenser		
REFRIGERANT	R134a (185g)		
LUBRICATING OIL	FREOL @15G (320 cc)		
DRIER	1Ø0.83		

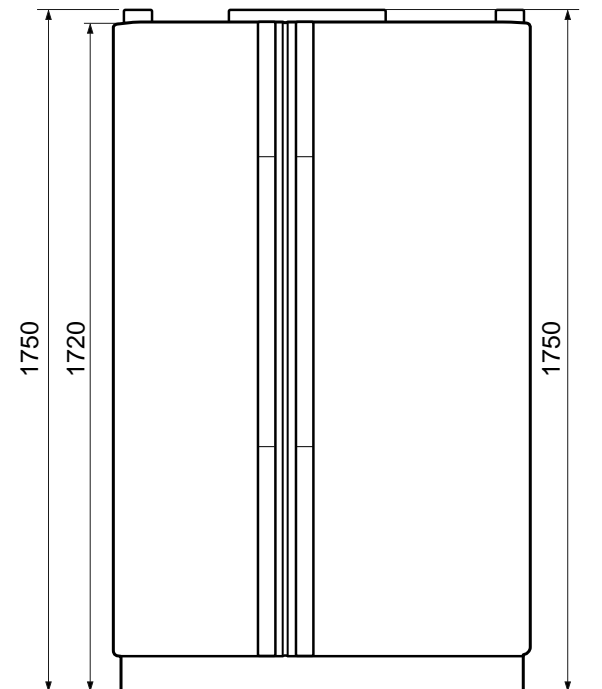

<Front View>

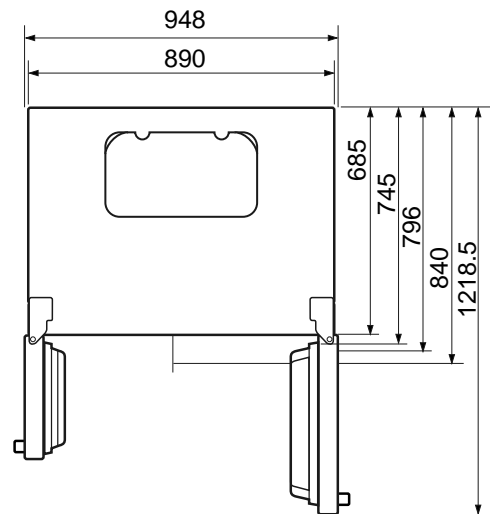

<Plane View>

# SPECIFICATIONS

## 4. Ref No. : GR-B207 / GR-B197

ITEMS		SPECIFICATIONS	ITEMS	SPECIFICATIONS
DIMENSIONS (mm)	B207	890(W)×755(D)×1750(H)	CAPILLARY TUBE	MOLECULAR SIEVE XH-7
	B197	890(W)×725(D)×1750(H)	FIRST DEFROST	4 - 5 Hours
NET WEIGHT (kg)		109	DEFROST CYCLE	13 - 15 Hours
COOLING SYSTEM		Fan Cooling	DEFROSTING DEVICE	Heater, Sheath
TEMPERATURE CONTROL		Micom Control		Heater, L-Cord
DEFROSTING SYSTEM		Full Automatic	ANTI-FREEZING HEATER	Damper Heater
		Heater Defrost	FREEZER LAMP	40W (1 EA)
INSULATION		Cyclo-Pentane	REFRIGERATOR LAMP	40W (1 EA)
COMPRESSOR		P.T.C. Starting Type	DISPENSER LAMP	15W (1 EA)
EVAPORATOR		Fin Tube Type		
CONDENSER		Wire Condenser		
REFRIGERANT		R134a (185g)		
LUBRICATING OIL		FREOL @15G (320 cc)		
DRIER		1Ø0.83		

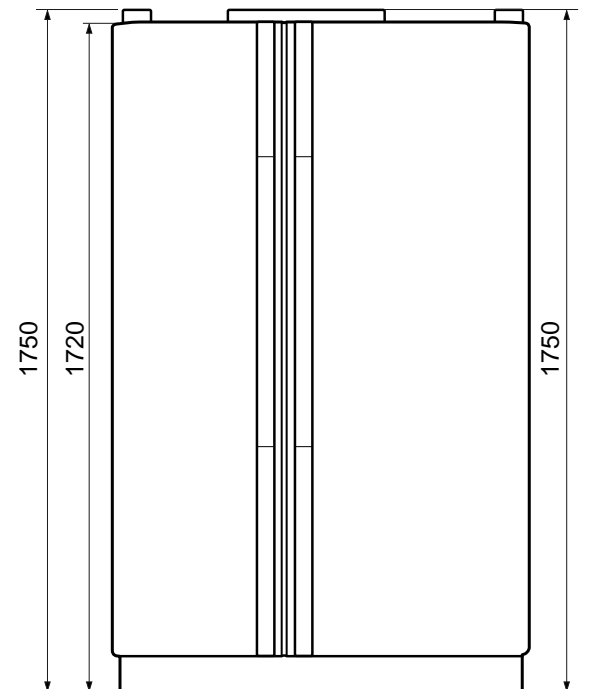

<Front View>

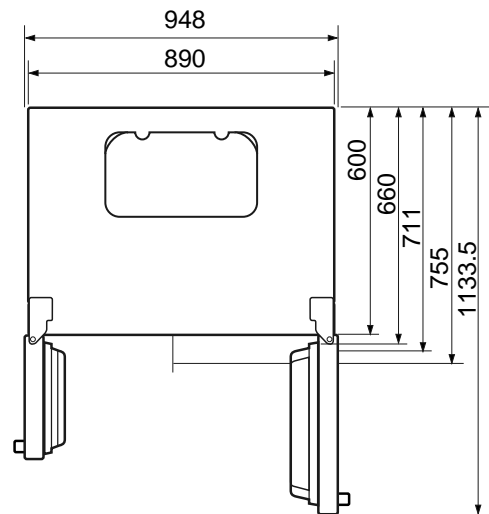

<Plane View>

# PARTS IDENTIFICATION

## 1. Ref No. : GR-P247ER, GR-P207ER

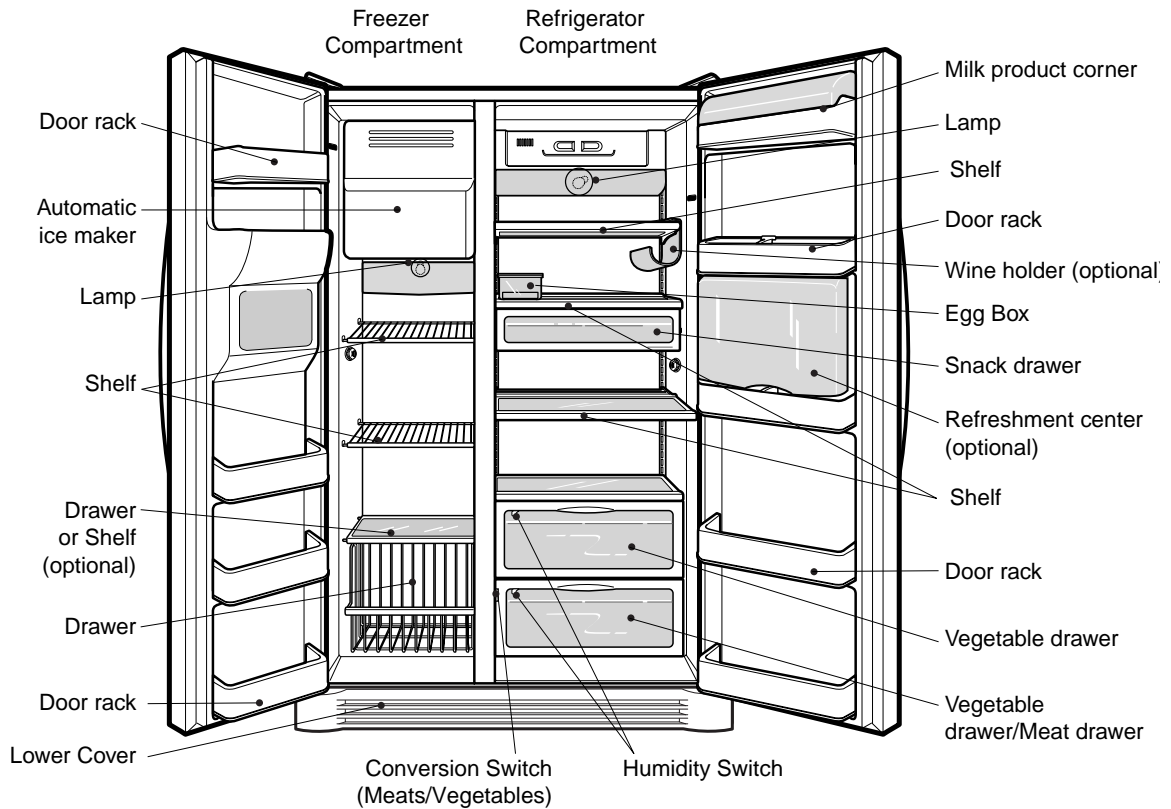
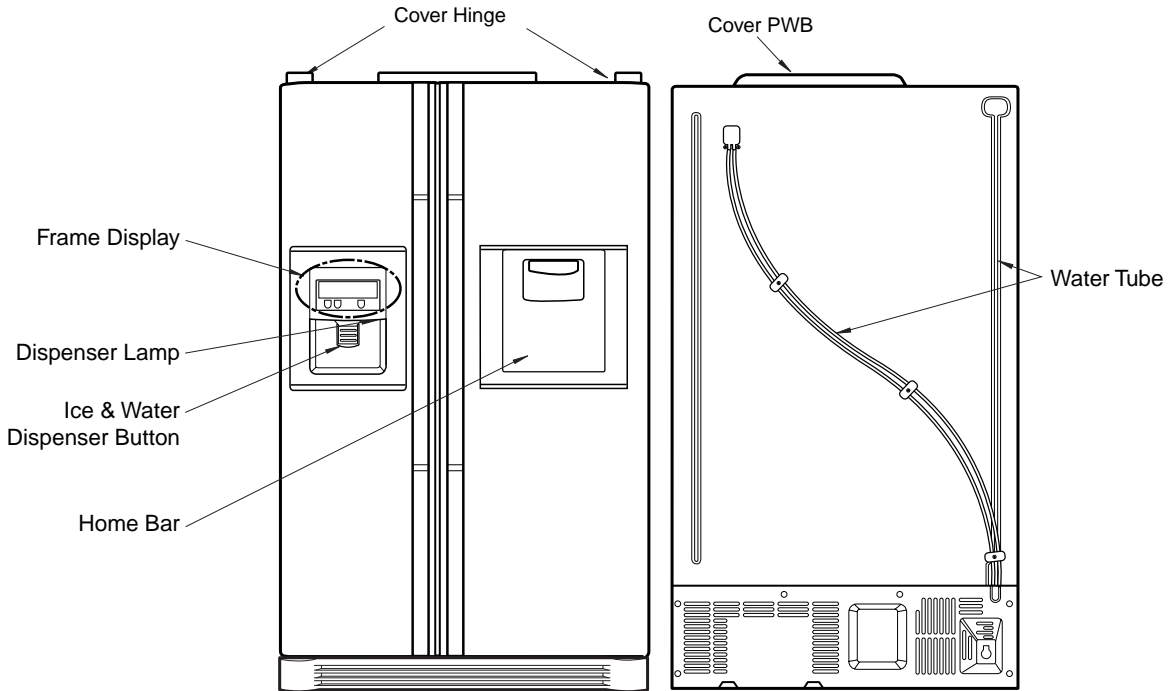

# PARTS IDENTIFICATION

## 2. Ref No. : GR-P247EQ, GR-P207EQ

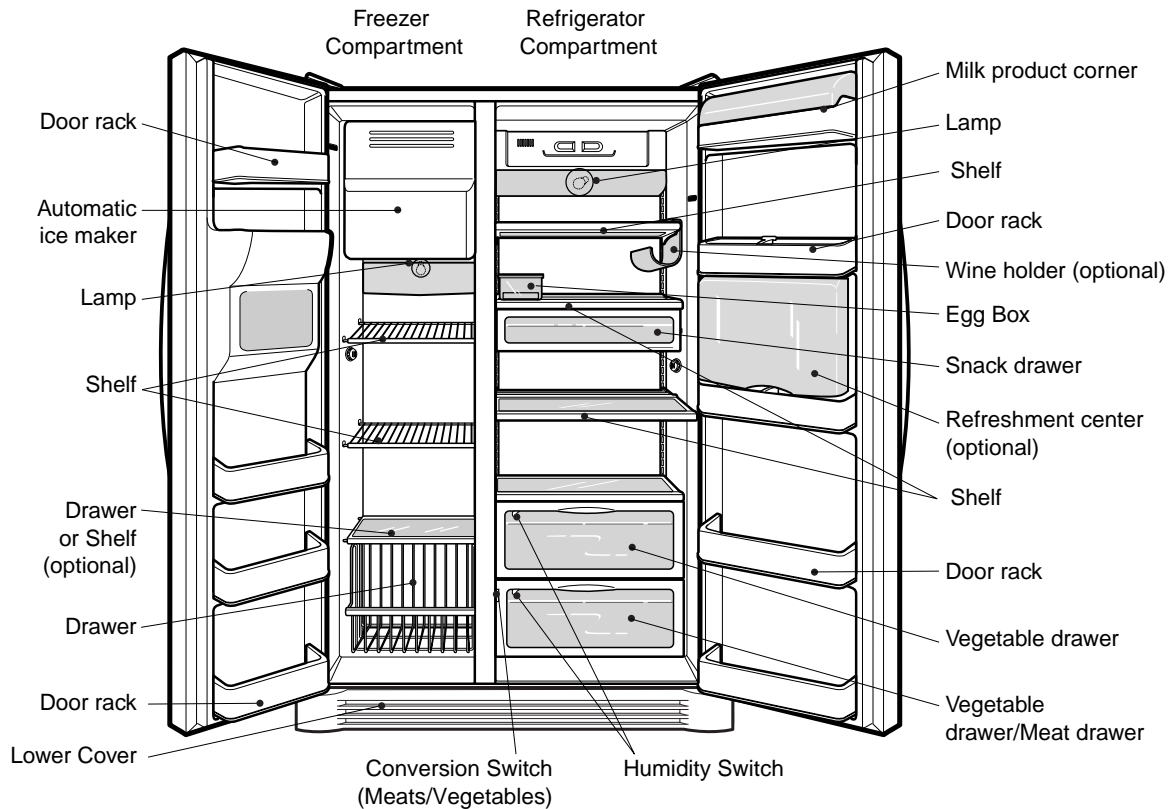
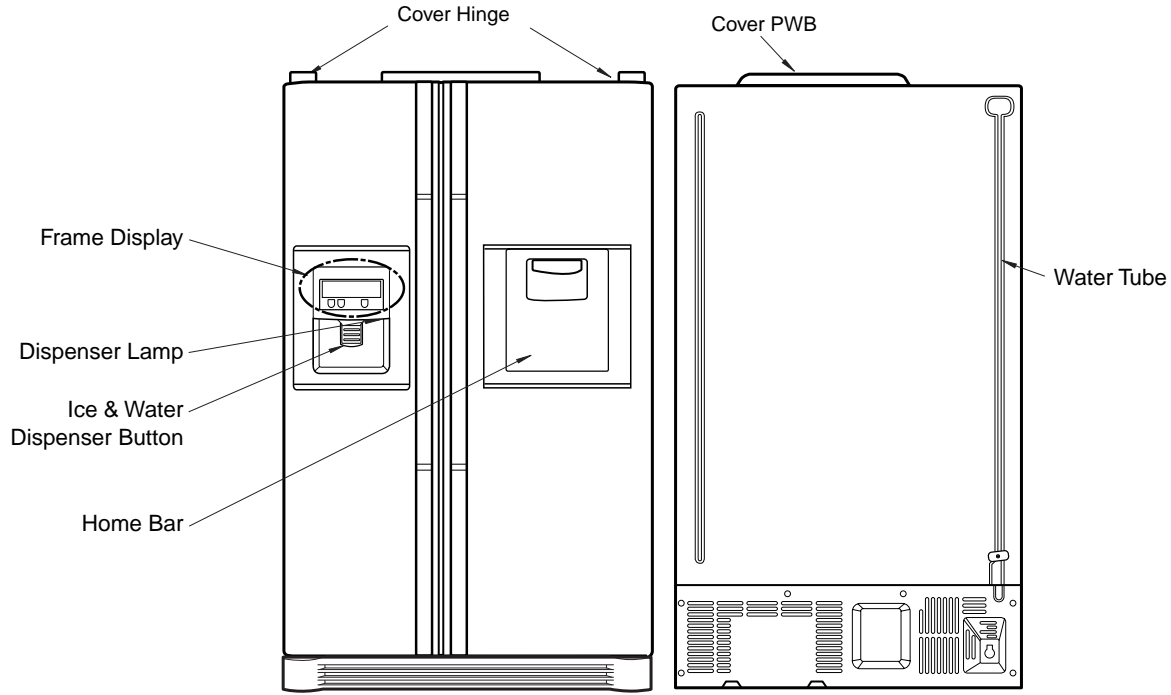

# PARTS IDENTIFICATION

## 3. Ref No. : GR-L247ER, GR-L207ER

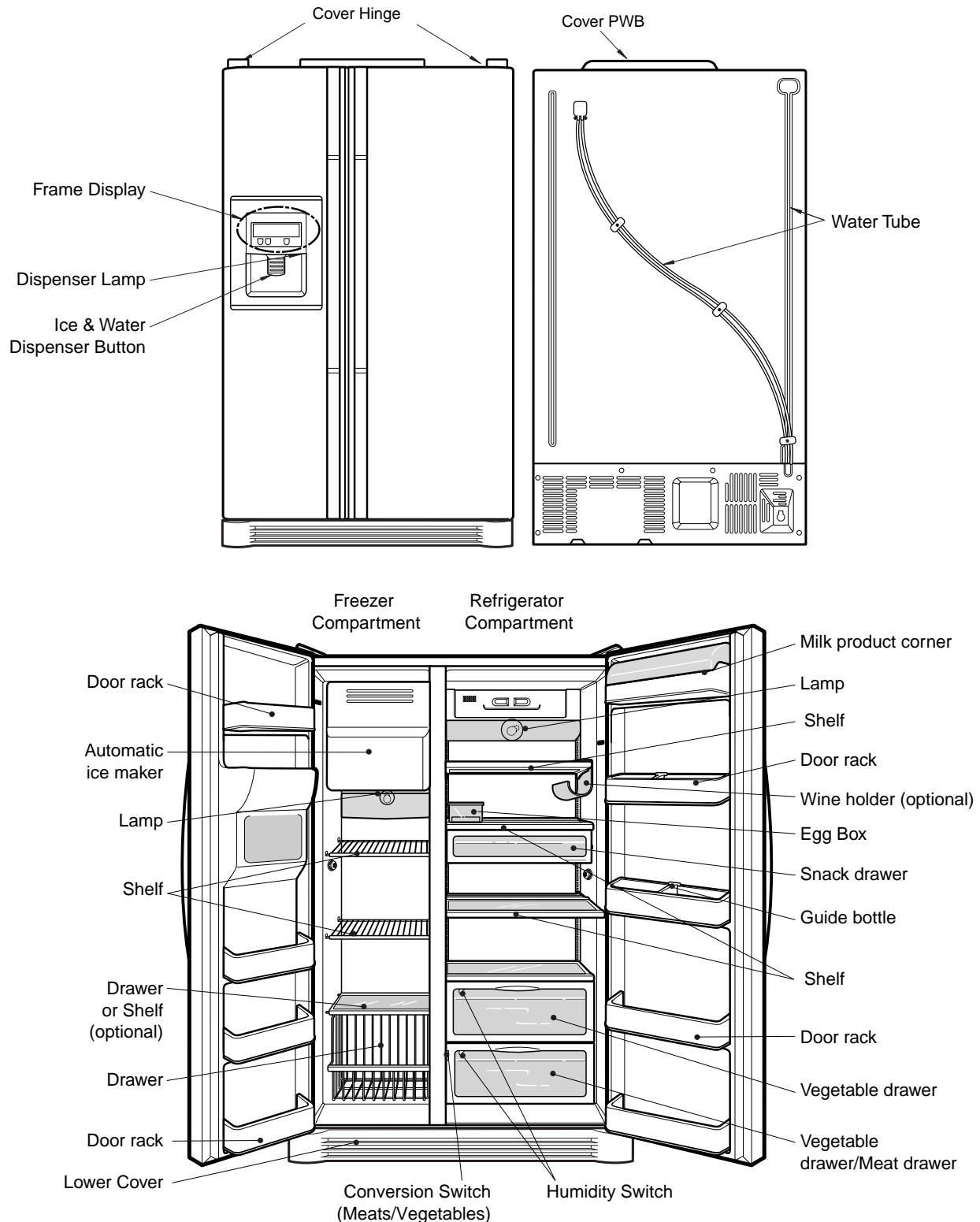

# PARTS IDENTIFICATION

## 4. Ref No. : GR-L247EQ, GR-L207EQ

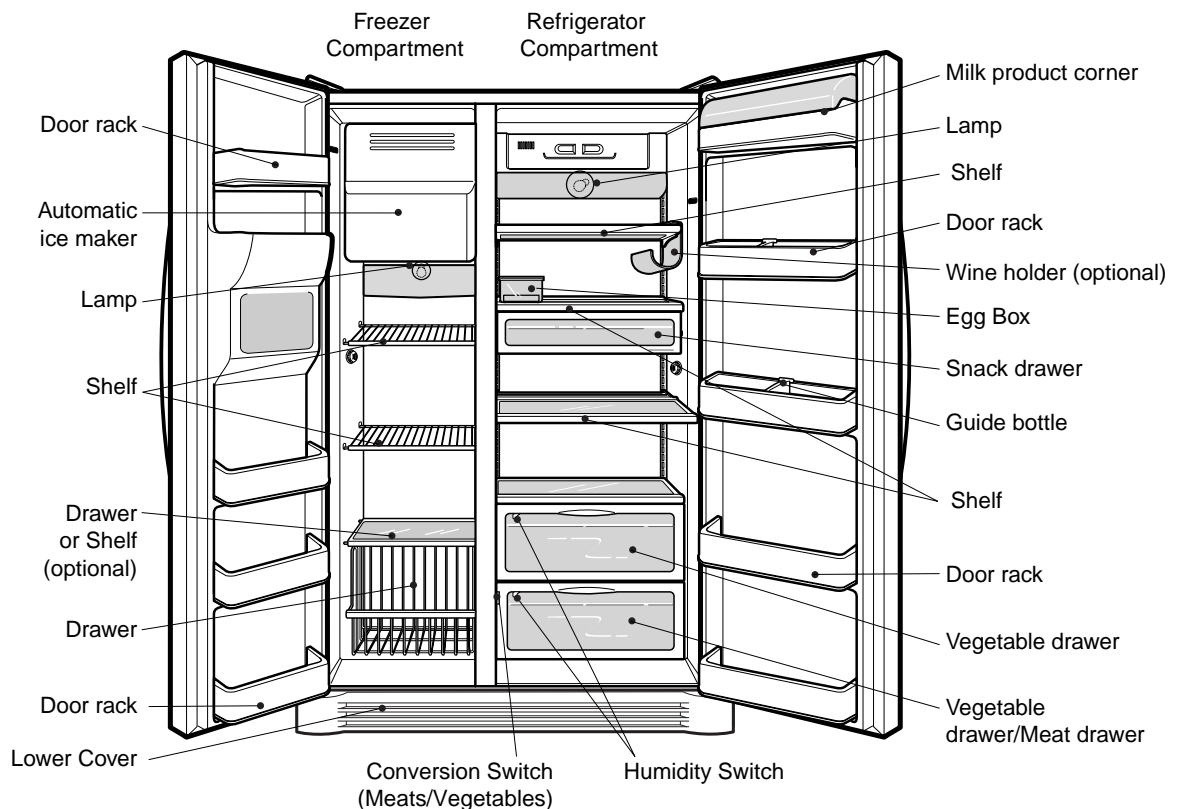
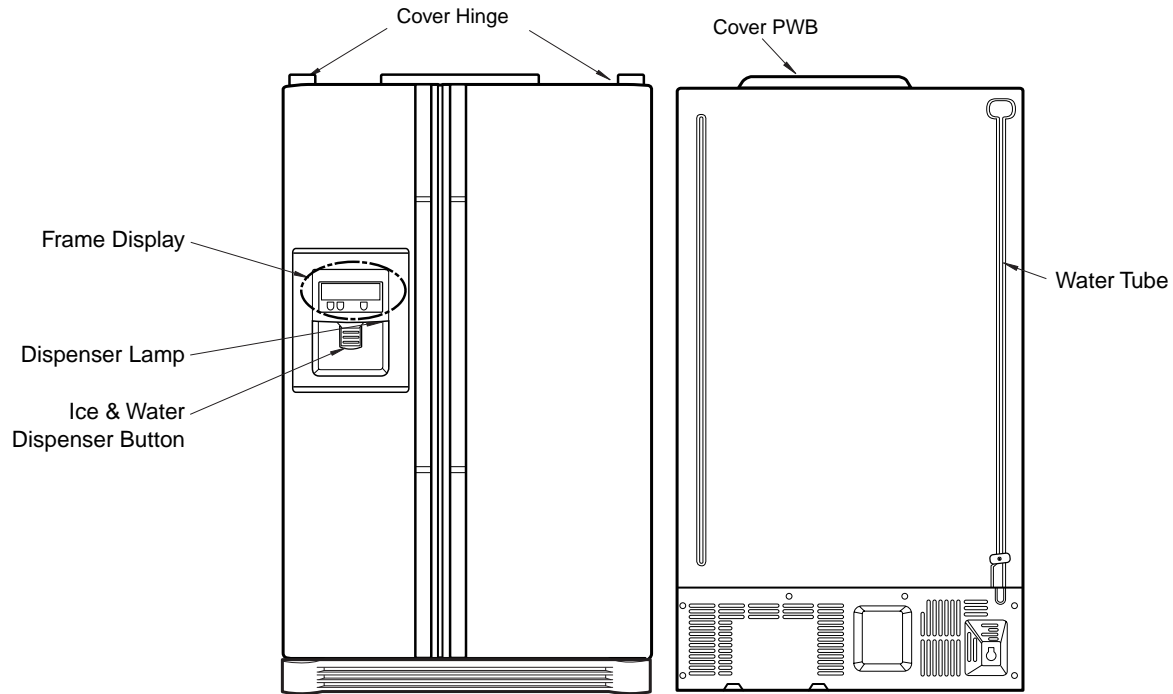

# PARTS IDENTIFICATION

## 1. Ref No. : GR-C247EC, GR-C207EC

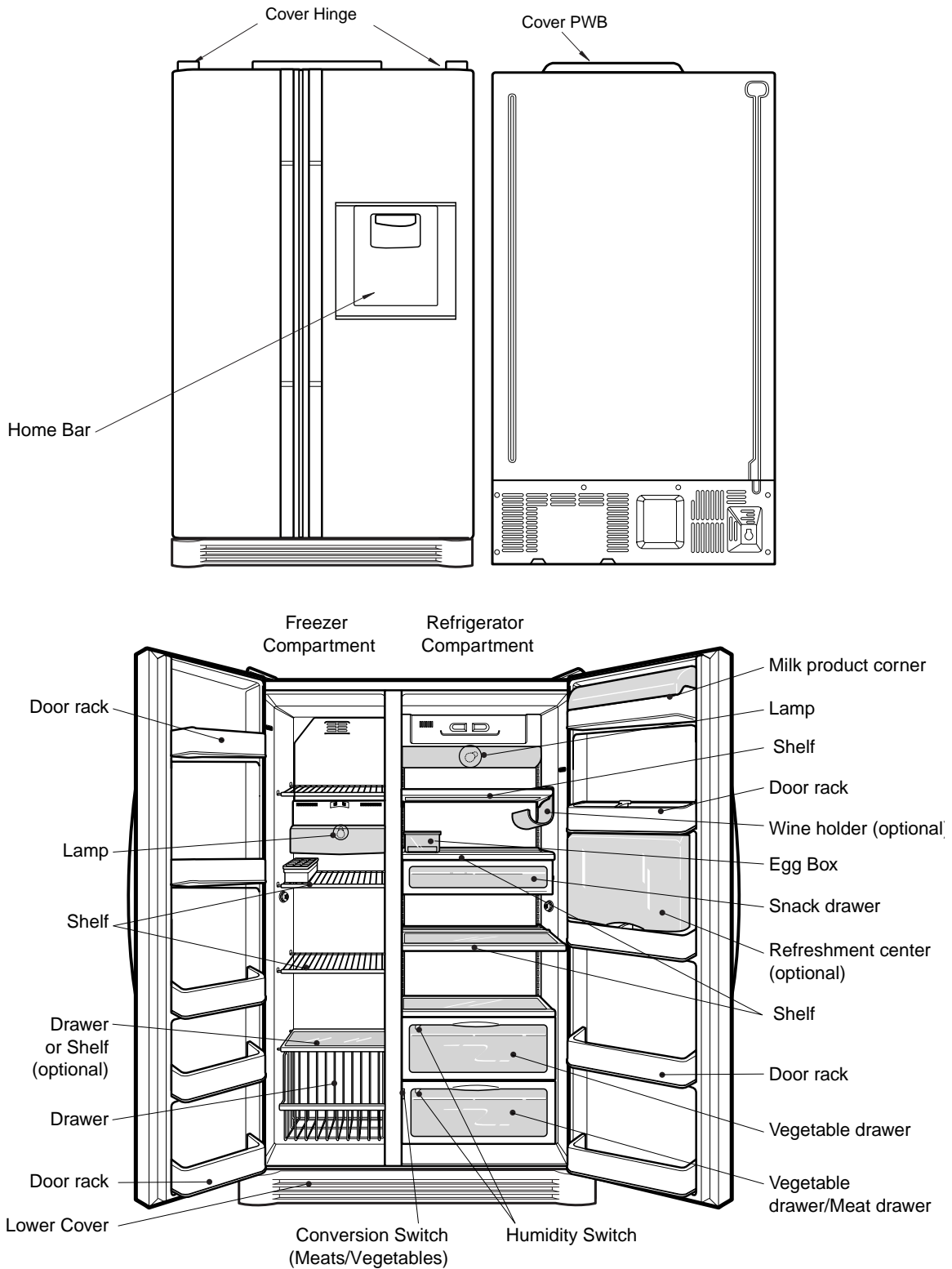



# PARTS IDENTIFICATION

3. Ref No. : GR-B247, GR-B207, GR-B197

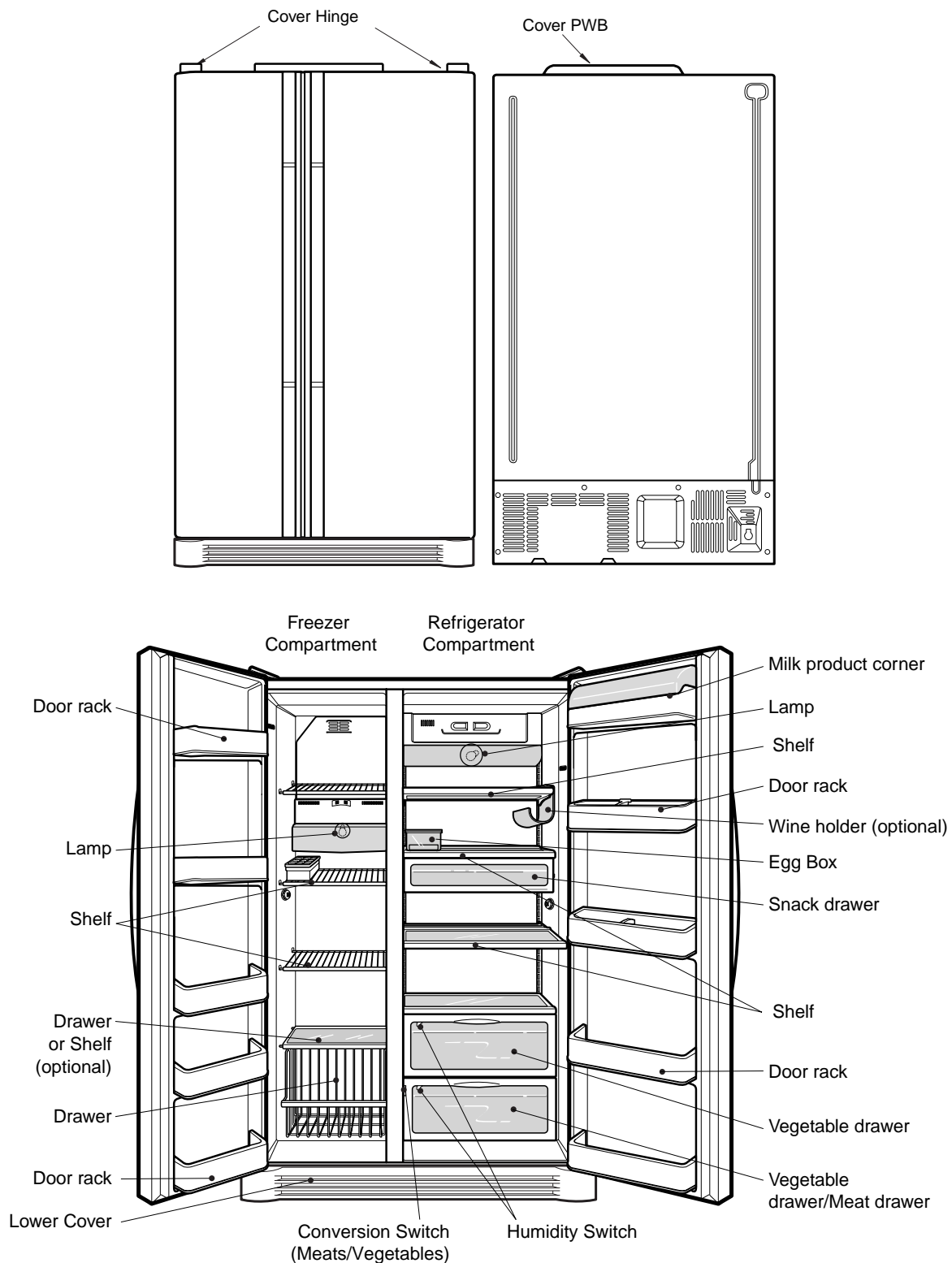

# HOW TO INSTALL REFRIGERATOR

## 1. How to Adjust Door Height of Refrigerator

■ Make the refrigerator level first. (If the refrigerator is not installed on the flat floor, the height of freezer and refrigerator door may not be the same.)

1. If the height of freezer door is lower than that of refrigerator compartment :

2. If the height of freezer door is higher than that of refrigerator compartment :

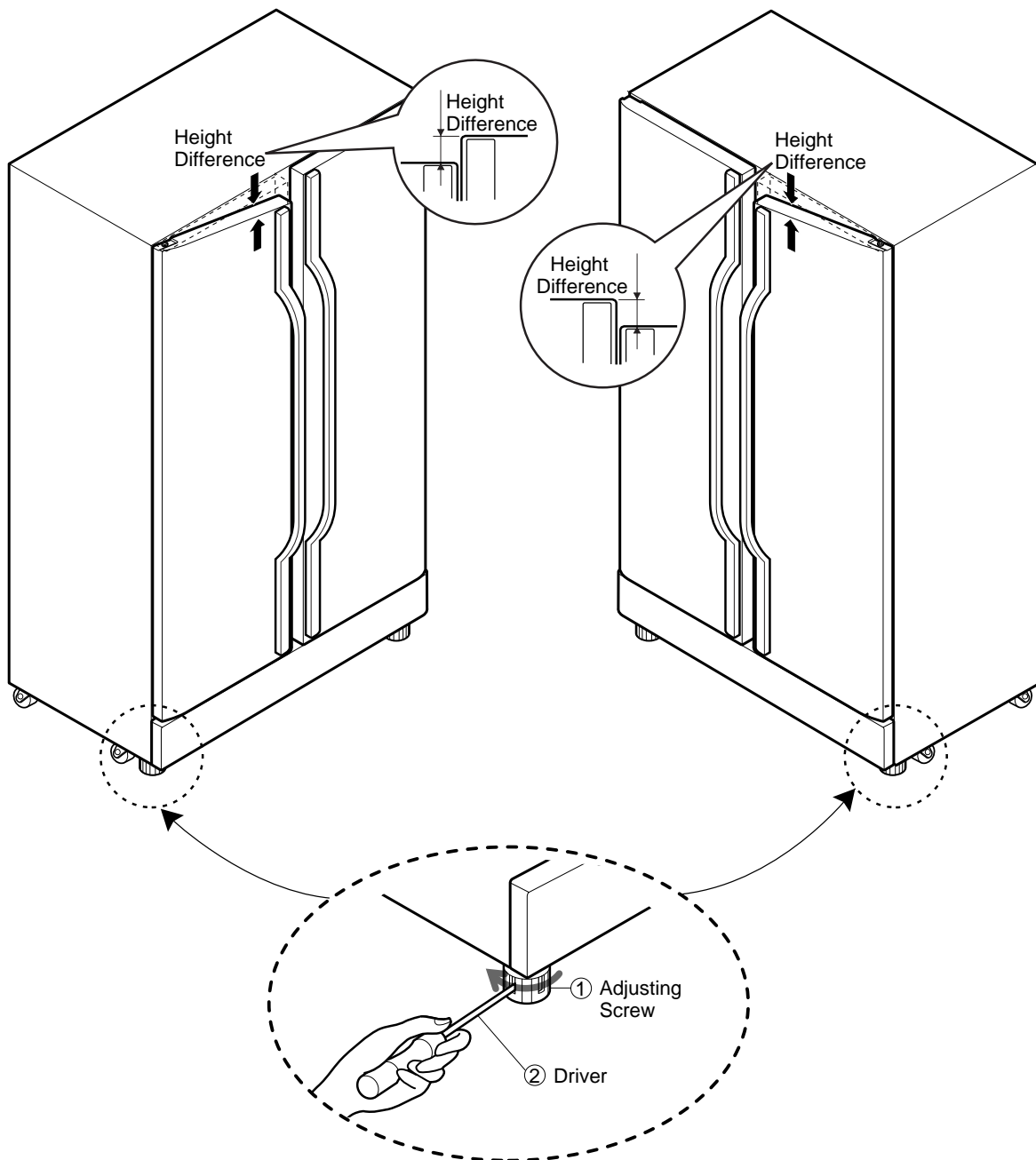

Insert a driver ② into the groove ① of adjusting screw and rotate driver in arrow direction (clockwise) until the refrigerator becomes horizontal.

Insert a driver ② into the groove ① of adjusting screw and rotate driver in arrow direction (clockwise) until the refrigerator becomes horizontal.

# HOW TO INSTALL REFRIGERATOR

## 2. How to Install Water Pipe

### ■ Before Installation

1. The icemaker requires the water pressure of 1.5 - 8.5kgf/cm<sup>2</sup>. (It is acceptable if city water fills a cup of 180cc with water for 3 seconds)
2. Install booster pump where the city water pressure is below 1.5kgf/cm<sup>2</sup> for normal operation of water and ice dispenser.
3. The total length of water pipe shall be less than 12m. Do not bend the pipe at right angle. If the length is more than 12m, there will be troubles on water supply due to water pressure drop.
4. Please install water pipe where there is no heat around.

### 2-1. When connecting directly to the water tap.

#### ■ Please confirm the following installation parts.

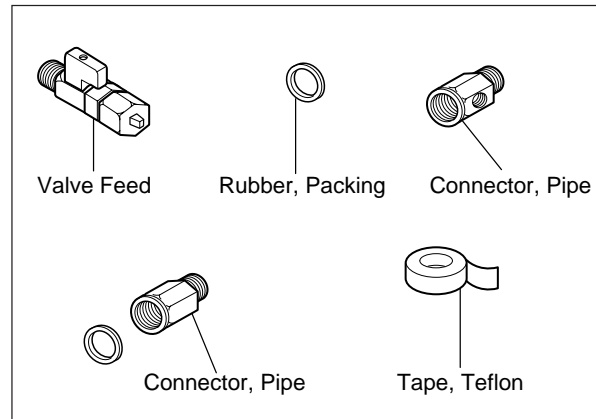

Class.	Shape and Spec.	Nomenclature	P/No	Remarks
Convertible Water Valve		Valve Feed	5221JA3001A	Common Use
Water Connector		Connector, (MECH) Pipe Conversion Connector(3/4") Balance Conector(3/4") Packing(ø24x3t)	4932JA3003A 6631JA3004A 6631JA3004B 3920JA3001B	No Holes
		Connector, (MECH) Pipe	4932JA3003B Conversion Connector(W25) Balance Conector(W25) Packing(ø23x3t)	6631JA3004C 6631JA3004D 3920JA3001A
		Connector, (MECH) Pipe Conversion Connector(W28) Balance Conector(W28) Packing(ø26x3t)	4932JA3003C 6631JA3004E 6631JA3004F 3920JA3001C	No Holes
		Connector, (MECH) Pipe Conversion Connector(1/2") Balance Conector(1/2") Packing(ø19x3t)	4932JA3003D 6631JA3004G 6631JA3004H 3920JA3001D	No Holes

# HOW TO INSTALL REFRIGERATOR

## 1. Connection of Pipe Connector A and B.

- 1) Turn off main valve of water pipe.
- 2) Disconnect water tap from piping by loosening nuts.
- 3) Connect pipe connector A and B to piping after sealing the pipe connector with sealing tapes.
- 4) Connect feed valve to pipe connector A.
- 5) If there is only one tap water pipe, connect pipe connector A only and install feed pipe.

- Caution :**
- Feed pipe should be connected to cold water line. If it is connected to hot water line, trouble may occur.
  - Please check rubber packing when connecting feed pipe.

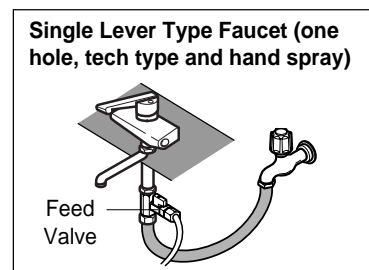
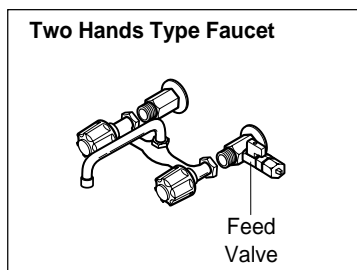
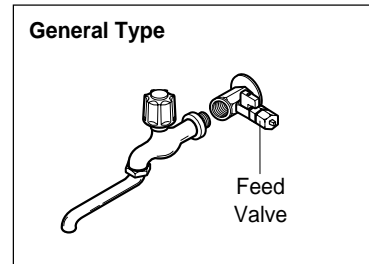
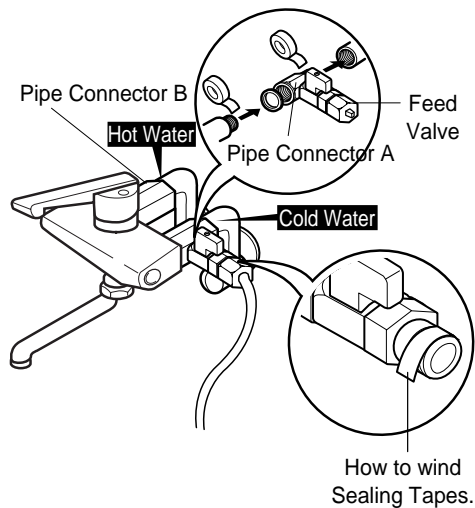

## 2. Water Supply

- 1) After the installation of feed water, plug the refrigerator to the earthed wall outlet, press the water dispenser button for 2 - 3 minutes, and confirm that the water comes out.
- 2) Check leakage at connecting part, then arrange water tube and locate the refrigerator at its regular place if there is no leaking.

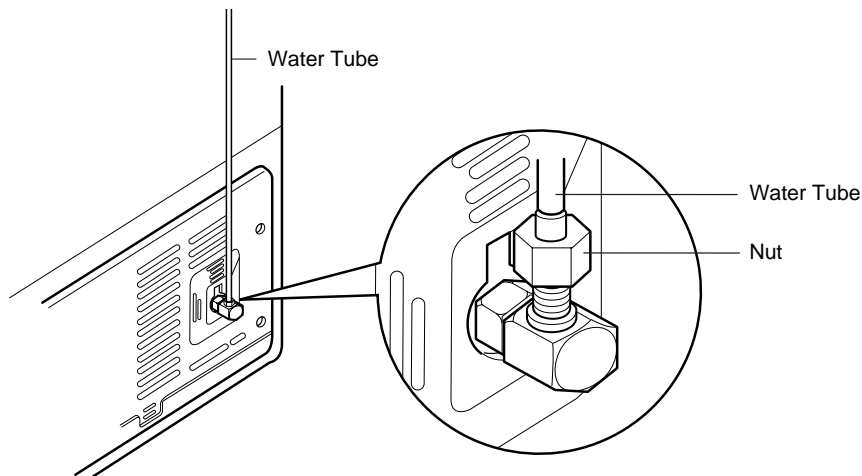

# HOW TO INSTALL REFRIGERATOR

## 3. When customer uses bottled water.

\*If customer wants to use bottled water, extra pump should be installed as shown below.

1. The pump system should not be on the floor (it may cause noise and vibration). Securely fasten the inlet and outlet nuts of pump.
2. If there is any leakage after installation, cut the water tube at right angle and reassemble.
3. When put the water tube end into the bottle, leave a clearance between bottle bottom and water tube end.
- 4 Check water coming out and any leakage.

**Caution :** • If feed tube is more than 4m, less water will come out due to pressure drops.

- Use standard feed tube to prevent leaking.

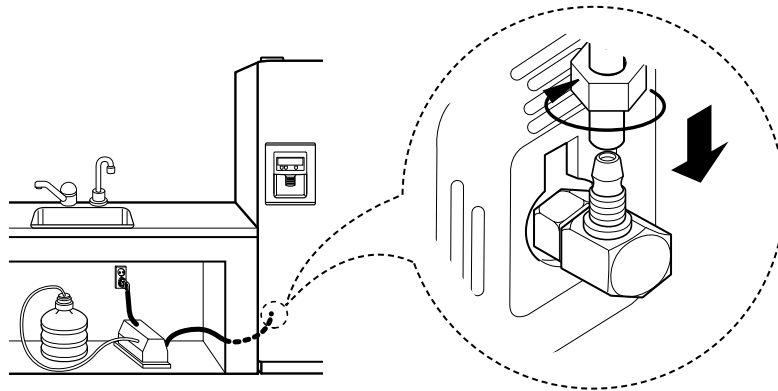

## ■ Outernal Filter

### 1. Filter Fixation

- 1) Connect feed tube to the filter outlet and water valve connecting tube.
- 2) Fix the filter at proper place around the sink where it is easy to replace the filter and to receive the cleaning water. Please consider the length of tube shall be less than 12m when locating filter.
- 3) When fixing the filter, use fixing plate and cable depending on the surrounding conditions.

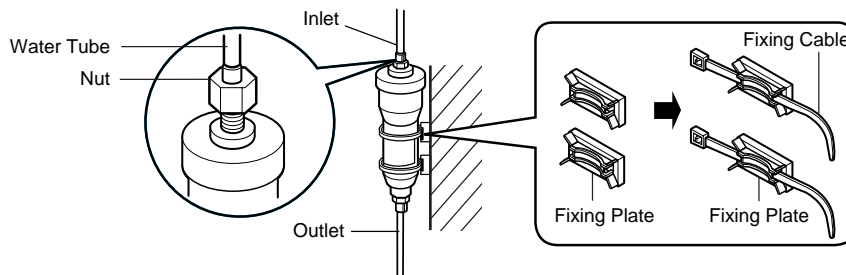

### 2. Filter Cleaning

- 1) Connect feed tube to the inlet of feed valve and filter.
- 2) Clean the main valve and feed valve with water for at least one minute until clean water comes out.

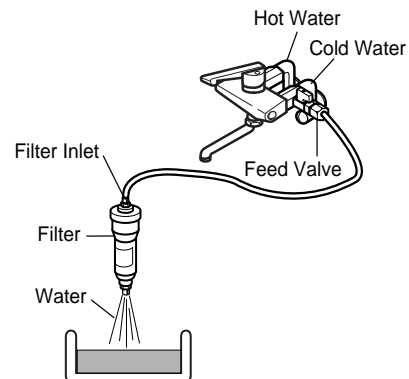

# HOW TO INSTALL REFRIGERATOR

## ■ Install Water Filter (Applicable to some models only)

### ■ Before Installing water filter

1. Before installing the filter, take out the top shelf of the refrigerator after tilting it to the direction (①) and lifting it to the direction (②) and move it to the lower part.
2. Remove the lamp cover by pressing the protrusion under the cover and pulling the cover to the front.

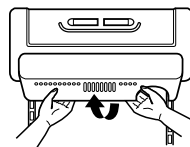
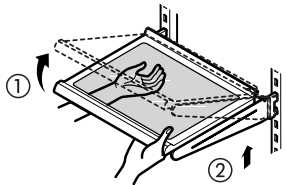

### ■ Installing water filter

#### 1. Initial installation of water filter

Remove the filter substitute cap by turning it counterclockwise (①) by 90 degrees and pulling it down.

**Note :** Keep it safe to use it later when you do not use the filter.

Remove the red cap from the filter and attach the sticker. Insert the upper part of the filter (①) after aligning with the guideline marked on the control box, and fasten it by turning it clockwise by 90 degrees.

**Note :** Check that the guideline and the fastening indication line are aligned.

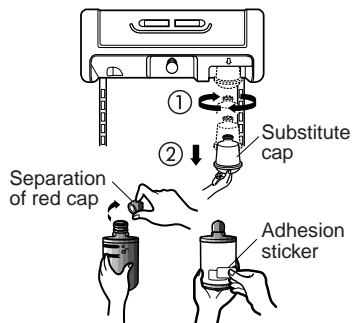

#### 2. Replacement of water filter

While holding the lower part of the filter, turn it counterclockwise (①) by 90 degrees and pull it down.

**Note :** Check that the guideline and the loosening indication line are aligned.

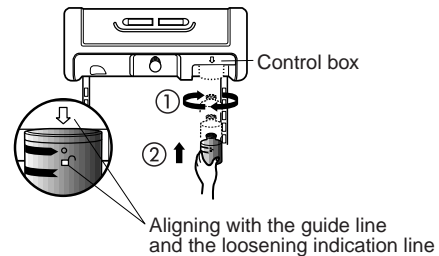
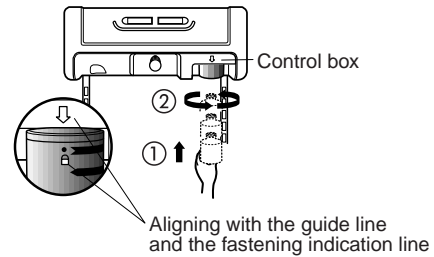

### ■ After installing water filter

Reassemble the lamp cover and the top shelf of the refrigerator. To place the top shelf of the refrigerator, raise the front part of the shelf a bit so that the hook of the shelf is fit into the groove.

In order to clean the water filter system, drain water for about 3 min.

**Note :** Then open the door of the refrigerator and check for water droppings on the shelf under the filter.

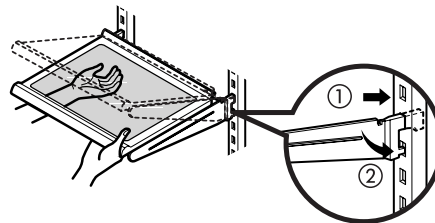
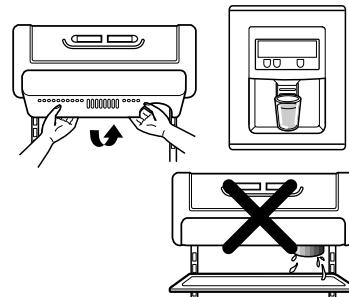

# HOW TO INSTALL REFRIGERATOR

## 3. How to Control the Amount of Water Supplied to Icemaker.

### 3-1. Confirm the amount of water supplied to the icemaker.

#### 1. Pull out the ice bank in the upper part of the freezer compartment.

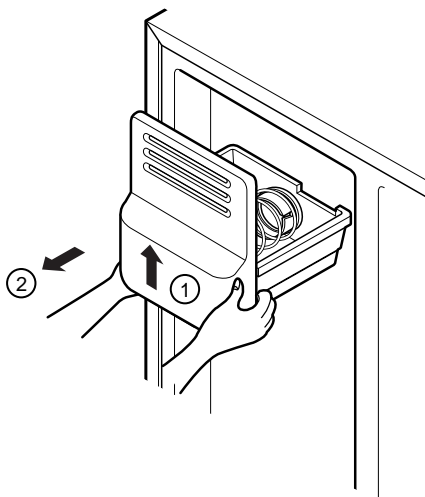

- Caution :**
- Do not put hands or tools into the chute to confirm the operation of geared motor. (it may damage refrigerator or hurt hands.)
  - Check the operation of motor with its operation noise.

#### 2. Apply electricity after connecting water pipe.

- 1) Press test switch under the icemaker for two seconds as shown below.
- 2) The bell rings(ding~dong) and ice tray rotates and water comes out from the icemaker water tube.
- 3) The water shall be supplied two or three times into the tray. The amount of water supplied for each time is small. Put a water container under the ice tray and press test switch.
- 4) When ice tray rotates, the water in it will spill. Collect the spilt water and throw away into the sink.
- 5) When ice tray has finished rotation, water comes out from the water tube. Confirm the amounts of water in the ice tray. (refer to fig. The optimum amount of water is 110cc)

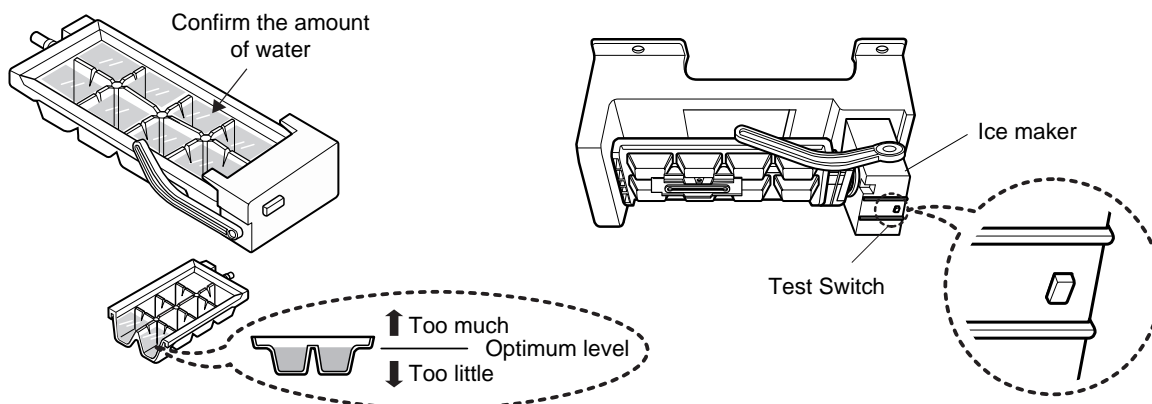

\* It is acceptable if the adjusted level of water is a bit smaller than optimum level.

# HOW TO INSTALL REFRIGERATOR

## 3-2. Control the amount of water supplied to the icemaker.

**Caution :** • Please unplug the power cord from the wall outlet and wait for more than three minutes before disconnecting PWB cover as 310V is applied in the control panel.

1. Disconnect PWB cover from the upper part of the refrigerator.

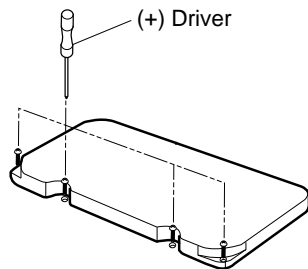

2. Adjust the amount of water supplied by using DIP switch.

### ■ Water Supplying Time Control Option

SWITCH NO			Water Supplying Time
S/W1	S/W2	S/W3	
OFF	OFF	OFF	6.5 Sec.
ON	OFF	OFF	5.5 Sec.
OFF	ON	OFF	6 Sec.
ON	ON	OFF	7 Sec.
OFF	OFF	ON	7.5 Sec.
ON	OFF	ON	8 Sec.
OFF	ON	ON	9 Sec.
ON	ON	ON	10 Sec.

- 1) The water supplying time is set at five seconds when the refrigerator is delivered.
- 2) The amount of water supplied depends on the setting time and water pressure (city water pressure).
- 3) If ice cube is too small, increase the water supplying time. This happens when too small water is supplied into the ice tray.
- 4) If ice cube sticks together, decrease the water supplying time. This happens when too much water is supplied into the ice tray.

**Caution :** When adjusting the amount of water supplied, adjust step by step. Otherwise the water may spill over.

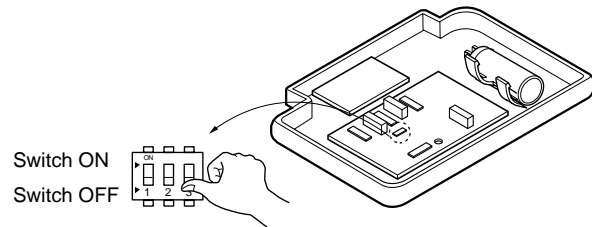

3. When adjustment of control switch for the amount of water supplied is complete, check the level of water in the ice tray.

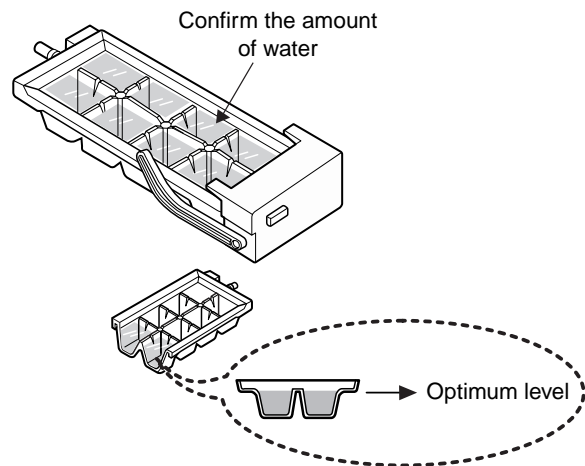



# MICOM FUNCTION

## 1. Monitor Panel

### 1-1. GR-P247, GR-P207, GR-L247, GR-L207

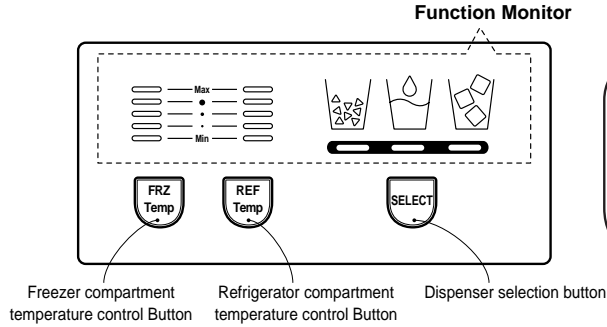



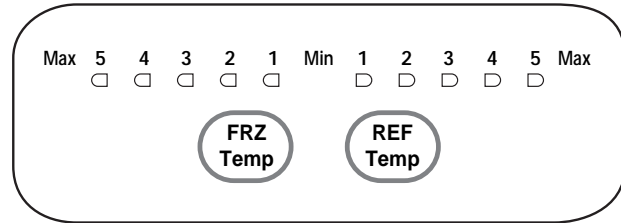

### 1-2. GR-C247, GR-C207, GR-B247, GR-B207, GR-B197



## 2. Description of Function

### 2-1. Function of Temperature Selection

Division	Power Initially On	1st Press	2nd Press	3th Press	4th Press
Change of Indication Lamp	 FRZ Temp    REF Temp	 FRZ Temp    REF Temp	 FRZ Temp    REF Temp	 FRZ Temp    REF Temp	 FRZ Temp    REF Temp
Temperature Control	Medium	Medium Max	Max	Min	Medium Min
Freezer Control	-19 °C (-18 °C) <-19 °C>	-22 °C (-20.5 °C) <-20.5 °C>	-23 °C (-22 °C) <-22 °C>	-15 °C <-16.5 °C>	-17 °C <-18 °C>
Refrigeration Control	3 °C <2 °C>	1.5 °C <1 °C>	0 °C <0 °C>	6 °C (7 °C) <4.5 °C>	4.5 °C <3 °C>

\* The temperature can vary  $\pm 3$  °C depending on the load condition.

\*( ) : 127V/60Hz, 110~115V/60Hz, 115V/60Hz Rating ONLY.

\*< > : TAIBEI

- When power is initially applied or reapplied after power cut, "Medium" is automatically selected.
- When the temperature selection switch in the freezer and refrigerator compartments is pressed, the light is on in the following sequence:  
"Medium" → "Medium Max" → "Max" → "Min" → "Medium Min" → "Medium"
- The temperature setting condition of freezer and refrigerator compartments shall not be indicate in the standard model (GR-P247, GR-P207, GR-L247, GR-L207, GR-C247, GR-C207, GR-B247, GR-B207) when refrigerator or home bar door is closed.

# MICOM FUNCTION

## 2-2. Control of Variable Speed Fan in the Refrigerator Compartment

1. Fan motor in the freezer compartment shall change from standard to high speed rpm in order to increase cooling speed and load corresponding speed.
2. High speed rpm is only used for the initial power application and load corresponding operation. But standard rpm is used in the general working conditions.
3. Fan motor in the freezer compartment operates normally when freezer, refrigerator, or home bar door opens and fan motor in the freezer compartment operates (the speed changes from high to standard rpm if fan motor operates at high speed rpm). But fan motor in the freezer compartment stops when refrigerator or home bar door is open and refrigerator compartment door is closed.

## 2-3. Door Opening Alarm

1. Buzzer warns when freezer, refrigerator, or home bar door is kept open for more than 1 minute.
2. Buzzer warns 3 times at 0.5 second interval and then 3 times at 0.5 second on and off in every 30 seconds if door is kept open for more than 1 minute.
3. Warning is released when freezer, refrigerator, or home bar door is closed during door opening alarm.

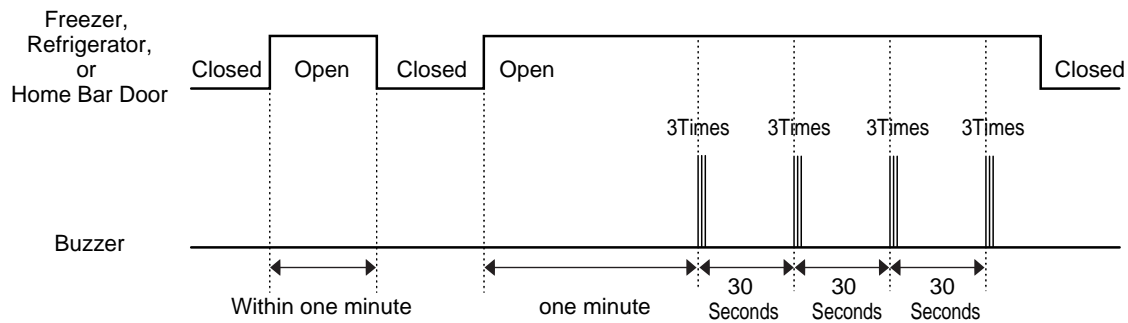

## 2-4 Button Selection Buzzer Sound

1. "Bell" sounds when button on the front display is pressed.

## 2-5. Forced Start, Forced Defrost Buzzer Warning

1. When test button in the main PWB is pressed, "beep" sounds.
2. When forced start is selected, warning sounds three times for 0.2 second on and 1.8 seconds off.
3. When forced defrost is selected, warning sounds three times in the following cycle: 0.2 second on and 0.2 second off, 0.2 second on and 0.2 second off, and 0.2 second on and 1.0 second off.

## 2-6. Functions of Defrost

1. Defrost starts whenever the compressor operation time accumulates to seven to seven and a half hours.
2. Defrost starts whenever the compressor operation time accumulates to four to four and a half hours if power is initially applied (or reapplied after power cut).
3. Defrost completes when the temperature of defrost sensor reaches at 5 °C. Faulty defrost is indicated if the defrost sensor does not reach at 5 °C after 2 hours of defrosting.
4. Defrost does not work when defrost sensor is out of order (wire cut or short-circuit).

# MICOM FUNCTION

## 2-7. Electric Equipment Sequential Operation

Electric equipment such as compressor, defrost heater, cooling fan, step motor damper, etc. operates in the following sequence when power is initially applied and test is completed in order to reduce noise and parts damage.

Function	Operation Sequence	Remarks
When power is initially applied	<p>Defrost sensor temperature is above 10 °C (purchased or house-moving)</p> <pre>           graph LR             A[POWER ON] -- 0.5 sec. --&gt; B[COMP ON]             B -- 0.3 sec. --&gt; C[FAN 1400 High Speed Operation ON]             C -- 0.3 sec. --&gt; D[STEP MOTOR DAMPER ON]             D -- 0.3 sec. --&gt; E[HOME BAR HEATER ON]           </pre>	If there is any error in functions, initial starting does not work.
	<p>Defrost sensor temperature is below 10 °C (power cut or service)</p> <pre>           graph LR             A[POWER ON] -- 0.5 sec. --&gt; B[DEFROST HEATER ON]             B -- 8 sec. --&gt; C[DEFROST HEATER OFF]             C -- 0.3 sec. --&gt; D[HOME BAR HEATER ON]             D -- 5 sec. --&gt; E[HOME BAR HEATER OFF]             E -- 0.3 sec. --&gt; F[WATER TANK HEATER ON]             F -- 5 sec. --&gt; G[WATER TANK HEATER OFF]             G -- 0.3 sec. --&gt; H[COMP ON]             H -- 27 sec. --&gt; I[FAN 1170 Standard Operation ON]             I -- 0.3 sec. --&gt; J[STEP MOTOR DAMPER ON]           </pre>	
TEST MODE	<p>Test Mode 1 (Forced Start)</p> <pre>           graph LR             A[TEST S/W Press Once] --&gt; B[OTHER LOADS OFF]             B -- 0.3 sec. --&gt; C[COMP ON]             C -- 0.3 sec. --&gt; D[FAN 1400 High Speed Operation ON]             D -- 0.3 sec. --&gt; E[STEP MOTOR DAMPER ON]           </pre>	If switch is pressed one more or defrost sensor temperature is above +5 °C, it returns to test mode and restarts. (compressor shall operate after 7 minutes)
	<p>Test Mode 2 (Check Freezer fan )</p> <pre>           graph LR             A[TEST S/W Press Twice] --&gt; B[COMP OFF]             B -- 0.3 sec. --&gt; C[FAN 1400 High Speed Operation OFF]             C -- 0.3 sec. --&gt; D[FAN 1170 Standard Operation ON]             D -- 0.3 sec. --&gt; E[STEP MOTOR DAMPER OPEN]           </pre>	
	<p>Test Mode 3 (Forced defrost)</p> <pre>           graph LR             A[TEST S/W Press Three Times] --&gt; B[FAN 1170 Standard Operation OFF]             B -- 0.3 sec. --&gt; C[DEFROST HEATER ON]             C -- 0.3 sec. --&gt; D[STEP MOTOR DAMPER CLOSE]           </pre>	

# MICOM FUNCTION

## 2-8. Function of Trouble Diagnosis

1. Function of trouble diagnosis is to make the repair service easy when the refrigerator is out of order during service.
2. The function control button does not work but the recognition sound is heard when the refrigerator is out of order.
3. It returns to normal conditions when trouble code led is off. (reset)
4. Trouble code is indicated by the freezing temperature indicator led in the refrigerator display. All leds except trouble code are off.

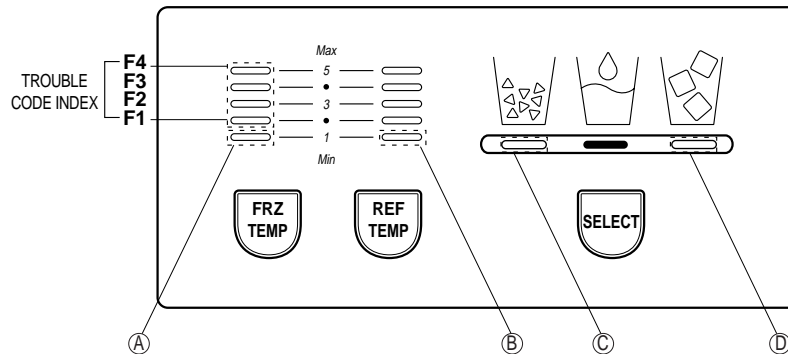

● : On    ● : Off    ● : Normal

No.	Trouble	Trouble Code Indicator				Troubles	Operation conditions during Trouble			
		F4	F3	F2	F1		Compressor	Freezer Fan	Defrost Heater	Step motor Damper
1	Abnormal Freezer sensor.	●	●	●	●	Freezer sensor short	15 min. on/ 15 min. off	Standard RPM	●	●
2	Abnormal Refrigerator sensor 1 (R1) (Upper part in the refrigerator compartment)	●	●	●	●	Refrigerator sensor 1 short circuit	●	Standard RPM	●	Note 2)
3	Abnormal Refrigerator sensor 2 (lower part in the refrigerator compartment)					Refrigerator sensor 2 short circuit	●	Standard RPM	●	●
4	Abnormal Defrost sensor	●	●	●	●	Defrost sensor short circuit	●	Standard RPM	No defrosting	●
5	Failed defrosting	●	●	●	●	Defrost Heater, Temperature Fuse short circuit. Unplugged Connector (Indicated 4 hour later after trouble)	●	Standard RPM	●	●
6	Abnormal Open Air Temperature Detecting sensor					Open air temperature detecting sensor short circuit	●	●	●	
7	Abnormal ice making sensor					Defrost sensor short circuit.	●	●	●	●
8	Abnormal ice maker unit					Faulty Ice Maker Unit Motor or Hall IC, L/Wire short circuit. Faulty motor driving circuit.	●	Standard RPM	●	●

# MICOM FUNCTION

**Note 1)** When open air temperature detecting sensor, refrigerator sensor 2, ice maker unit, ice making sensor are abnormal, it is not indicated in the trouble code. But it is indicated while checking LED (press freezer and refrigerator temperature control buttons for more than 1 second at the same time).

Room Temperature Detection Sensor	Normal : (A) LED On. Abnormal : (A) LED Off.	The rest of LEDs are all on
Refrigerator Sensor 2 (lower shelf)	Normal : (B) LED On. Abnormal : (B) LED Off.	
Home Bar Sensor	Normal : (C) LED On. Abnormal : (C) LED Off.	
Ice Maker Unit	Normal : (D) LED On. Abnormal : (D) LED Off.	

**Note 2)** When refrigerator sensor is abnormal, it opens for 10 minutes and closes for 15 minutes.

## 2-9. Test Function

1. Test function is to check the function of PWB and products and to find defective parts when the refrigerator is out of order.
2. Test button is on the main PWB of the refrigerator. Test mode completes after 2 hours in maximum and returns to normal conditions.
3. Function control button does not work but button recognition sound is heard during the test mode.
4. When test mode is completed, unplug and replug the power cord to return to the normal conditions.
5. When sensor is abnormal in the test mode, test mode is released and trouble code is indicated.
6. Test mode does not work even test button is pressed when trouble code indicator is on.

Mode	Operation	Contents	Remarks
Test 1	Press test button once	<ol style="list-style-type: none"> <li>1. Continuous compressor operation</li> <li>2. Continuous freezer fan (high rpm) operation</li> <li>3. Defrost heater off.</li> <li>4. All display LEDs are on.</li> <li>5. Electronic stepping motor damper open (baffle is open).</li> </ol>	Forced start
Test 2	Press test button once in Test Mode 1	<ol style="list-style-type: none"> <li>1. Compressor off.</li> <li>2. Freezer fan (high rpm) off.</li> <li>3. Freezer fan (standard rpm) on.</li> <li>4. Defrost heater off.</li> <li>5. "Medium Weak" led in freezer and refrigerator temperature indicators are on.</li> <li>6. Step motor damper open condition (baffle is open)</li> </ol>	Check fan in the freezer compartment
Test 3	Press test button once in Test Mode 2	<ol style="list-style-type: none"> <li>1. Compressor is off.</li> <li>2. Freezer fan off.</li> <li>3. Defrost heater on.</li> <li>4. "Medium" leds in freezer and refrigerator temperature indicators are on.</li> <li>5. Step motor damper closed condition (baffle is closed)</li> </ol>	<ul style="list-style-type: none"> <li>• Return to normal conditions when defrost sensor is above 5 °C.</li> <li>• Forced defrost.</li> </ul>
Normal	Press test button once in test mode 3	Return to initial conditions	Compressor starts after seven minutes.

# MICOM FUNCTION

---

\* LED check function- When freezer and refrigerator temperature control buttons are pressed for more than 1 second at the same time, all LEDs on the display are on. And it returns to the normal conditions when the buttons are released.

\* Check of freezer fan rpm variation- Freezer fan speed changes from high speed to standard speed and vice versa for 30 seconds whenever freezer and refrigerator temperature control buttons are pressed at the same time for more than 1 second when freezer fan is in operation and returns to the previous rpm.

## 2-10. Functions of Ice Dispenser and Water Dispenser

1. Ice and cold water are available without opening refrigerator door.
2. The desired ice (crushed or cube) or cold water are dispensed when dispenser press button (rubber button) is pressed after selection of ice or cold water. When ice is selected, duct door opens by electric solenoid when dispenser press switch is pressed. When dispenser press switch is released, duct door closes after it opens for 5 seconds.
3. Ice and water dispensing function stops when freezer door is open.
4. Geared motor and solenoid are automatically off if there is no signal after 3 minutes when ice (crushed and cube) or water is selected and dispenser switch is pressed down. Solenoid (duct door) stops after 5 seconds when solenoid is off. (in order to protect short circuit from solenoid heat generation)
5. Dispenser Lamp On/Off Function. The dispenser lamp shall be on or off whenever dispenser button is pressed or released, respectively after selection of ice (crushed or cube) or water.
6. Water/Crushed Ice/Cube Ice Selection function
  - 1) It is to select water/crushed ice/cube ice by user from the function control part and it will be indicated and selected by pressing button.
  - 2) Crushed ice is automatically selected when power is initially on.
  - 3) When crushed ice is selected and its button is pressed, geared motor operates and crushed ice is dispensed.
  - 4) When cube ice is selected and its button is pressed, geared motor and ice solenoid operate and cube ice is dispensed.
7. Function of Water Dispenser
  - 1) When user selects water in the function control parts, it is indicated in the LED and water is selected.
  - 2) Water dispenser is a direct tap water connection type. The water solenoid valve on the right of machine room opens and water dispenses when user selects water and presses button.

# MICOM CIRCUIT DESCRIPTION

## 1. Description of PWB Circuit

### 1-1. Power Circuit

#### 1. GR-P247, GR-P207, GR-L247, GR-L207

Power circuit is composed of switching mode power supply (SMPS) electric parts. SMPS is composed of rectifying part (D1~D4, CE1) which converts AC to DC voltage, switching part (IC2) which switches this converted DC voltage, trans which transmits primary energy to secondary energy, secondary power source which transmits power to MICOM and IC, and feed back part (IC3, ZD1) which feeds back voltage to primary trans in order to maintain constant secondary voltage. The voltages at each part are as follows.

**Note :** If circuit is abnormal, repair it after 3 minutes when power cord is unplugged. Be care of electric shock as high voltage (DC 310 V) is applied to the circuit.

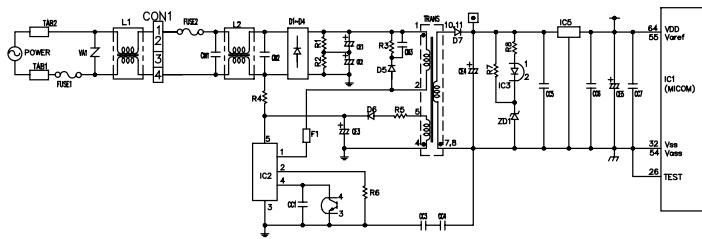

#### 2. GR-C247, GR-C207, GR-B247, GR-B207

In the trans secondary side is composed of power source (12 Vdc) for driving relay and power source (5 Vdc) which supplies power to MICOM and IC. Voltages in each part are as follows.

Position	VA1	CM1	CM2	CE2	CE4
Voltage	220 Vac	14 Vac	17 Vac	12 Vdc	5 Vdc

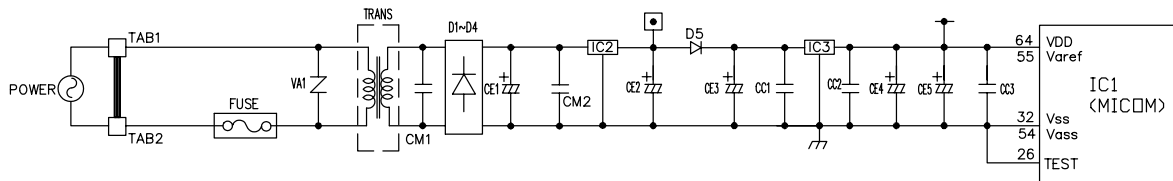

### 1-2. Oscillation Circuit

This is to generate basic time for synchronous clock and time calculation for internal logic element to send and receive information. Standard parts should be used as the time calculated by IC1 shall be changed or shall not work if OSC1 specification is changed.

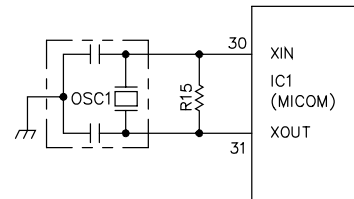

### 1-3. Reset Circuit

Reset circuit is to initialize RAM in MICOM (IC1) and make all functions to start from the initial conditions when power is initially applied or power is reapplied to MICOM after power cut. Low voltage is applied for 10 ms to the reset terminal of MICOM when power is applied. 5 voltage is applied to the reset terminal for general operation. (MICOM does not work when IC9(Reset IC) is failed)

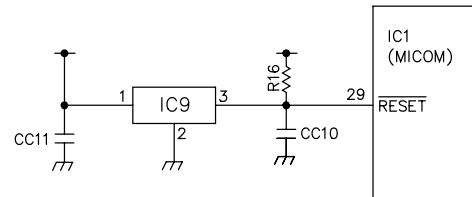

# MICOM CIRCUIT DESCRIPTION

## 1-4. Load/Dispenser Operation, Buzzer Driving, Door Opening Detecting Circuit

### 1. LOAD DRIVING CIRCUIT

\* Freezer fan motor shall stop when freezer or refrigerator door is open. Freezer fan motor shall immediately operate when freezer or refrigerator door is closed.

\* Door switches A, B, C, D, E, F of freezer and refrigerator are connected to the door opening detecting circuit in Micom.

\* Home bar door switch E, F is parallelly connected to the refrigerator door switch C, D. Therefore it can detect door opening when one of the door is open.

#### 1) GR-P247, GR-P207, GR-L247, GR-L207

Load Types	Machine Room	Defrost Heater	AC Converting Relay	Heater, Plate (W/TANK)	Refrigerator Fan Motor	
					High Speed	Standard Speed
Measuring Locations(IC 6)	No.10	No.11	No.12	No.16	No.13	No.14
Condition	ON	Below 1 V				
	OFF	12 V				

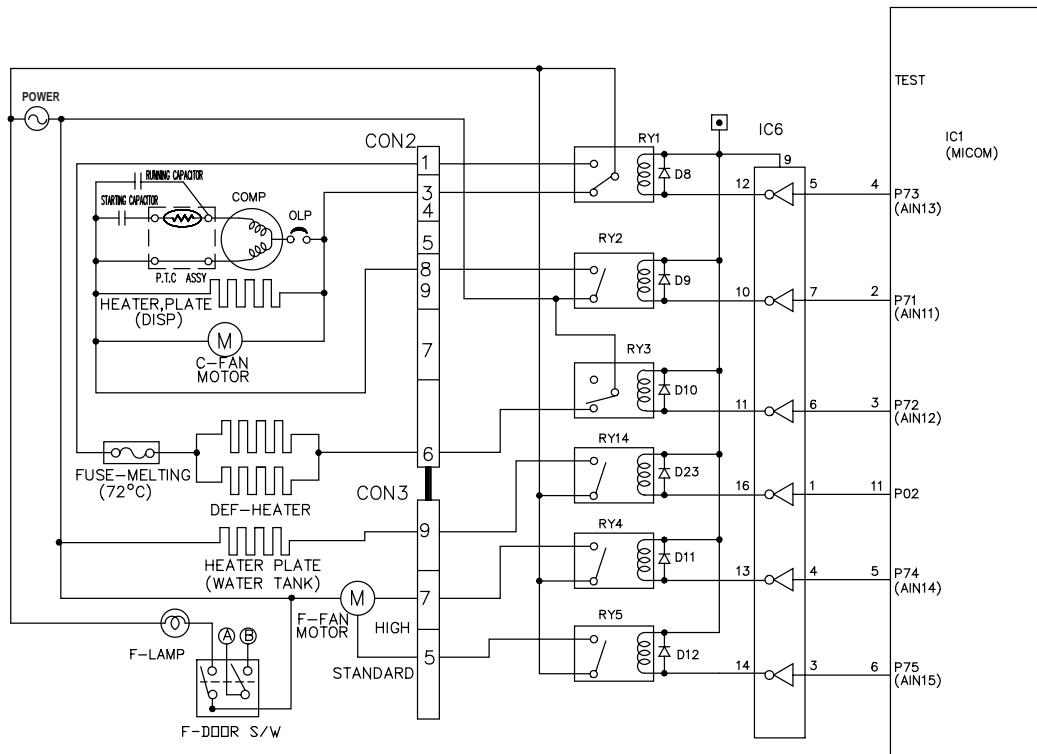



# MICOM CIRCUIT DESCRIPTION

## 2) GR-C247, GR-C207, GR-B247, GR-B207, GR-B197

- \* Freezer fan motor shall operate when freezer, refrigerator, or home bar door is open.
- \* Door switches A, B, C, D of freezer and refrigerator are connected to door opening detecting circuit in Micom.
- \* Home bar door switch E, F is parallelly connected to the refrigerator switch C, D. Therefore it can detect door opening when one of the door is open.

Load Types	Machine Room	Defrost Heater	AC Converting Relay	Refrigerator Compartment Lamp	Home Bar Heater	Refrigerator Fan Motor	
						High Speed	Standard Speed
Measuring Points(IC 4)	No.10	No.11	No.12	No.16	No.15	No.13	No.14
Conditions	ON	Below 1 V					
	OFF	12 V					

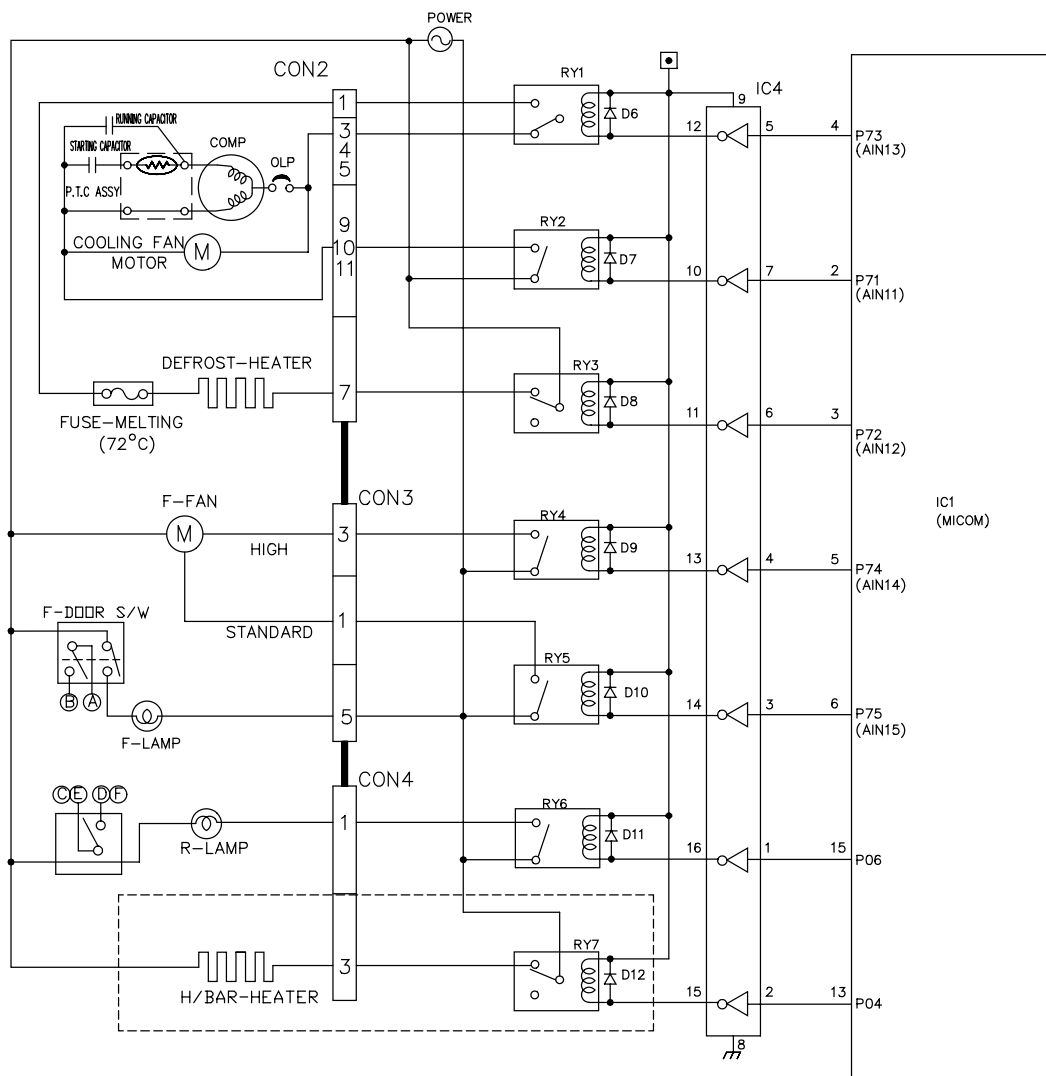

# MICOM CIRCUIT DESCRIPTION

## 2. Dispenser Operation Circuits GR-P247, GR-P207, GR-L247, GR-L207

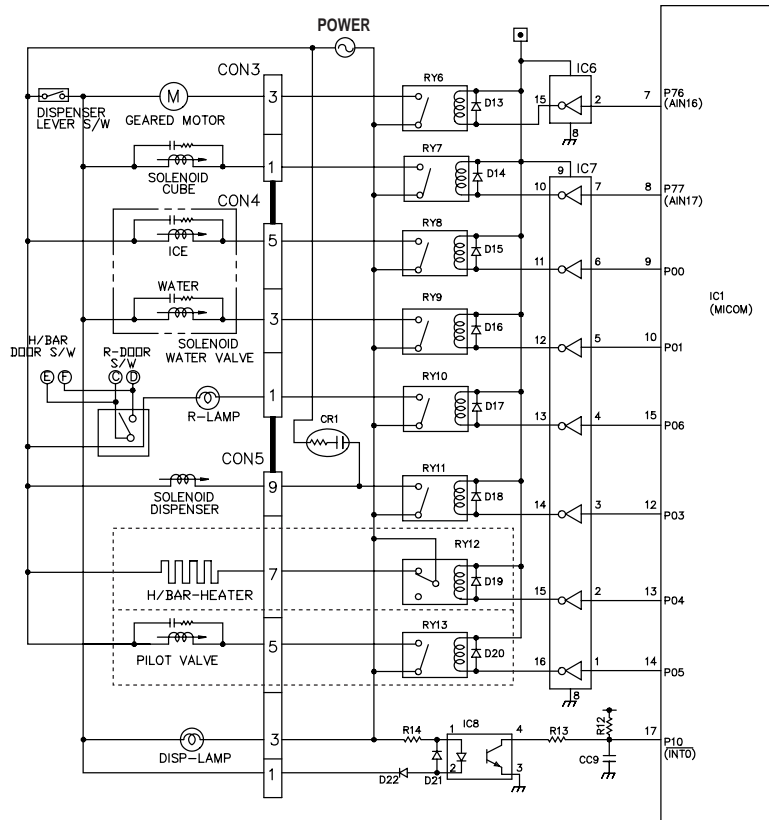

### 1) LOAD DRIVING CONDITION CHECK

LOAD TYPE	GEARED MOTOR	SOLENOID CUBE	WATER VALVE			SOLENOID DISPENSER	HOME BAR HEATER	Refrigerator Compartment Lamp
			ICE	WATER	PILOT			
Measuring Points	No.15(IC6)	No.10(IC7)	No.11(IC7)	No.12(IC7)	No.16(IC7)	No.14(IC7)	No.15(IC7)	No.13(IC7)
Conditions	ON	Below 1V						
	OFF	12V						

### 2) Lever Switch Detecting Circuit

Measuring Points	IC1(Micom) No. 17	
Lever S/W		
On(Press)	5V	0V
OFF	5V	

# MICOM CIRCUIT DESCRIPTION

## 3. Buzzer Driving Circuits

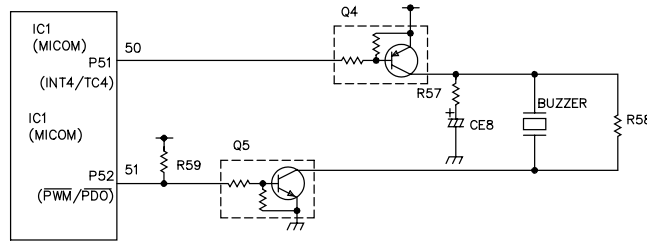

MEASURING POINTS	CONDITIONS	Bell sounds when button on display is pressed.	Beep sounds when warning door opening.	OFF
IC1 (No. 50 Pin)				0 V
IC1 (No. 51 Pin)				0 V

## 4. Door Opening Detecting Circuits

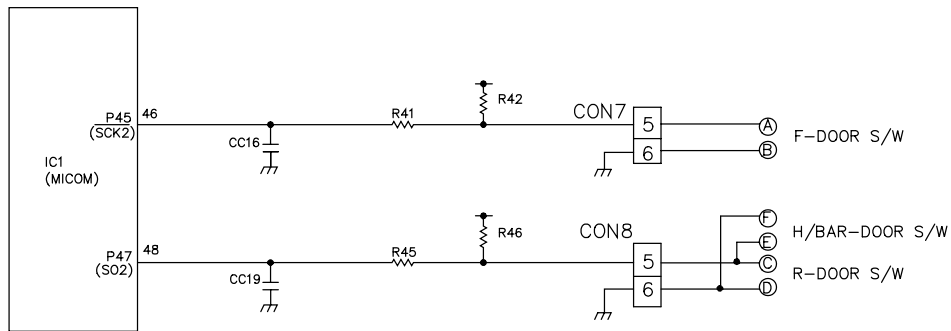

MEASURING POINTS	IC1 (MICOM) (Pin No. 46 and 48)
FREEZER / REFRIGERATOR DOOR	
CLOSED	5 V (A - B, C - D, E - F both ends S/W off conditions)
OPEN	0 V (A - B, C - D, E - F both ends S/W on conditions)

\* Door opening detecting switch ( A - B) can not detect door opening when switch ( A - B) or lead wire is failed even though freezer door switch is normal.

\* Refrigerator lamp shall not be on when refrigerator door switch can not detect door opening detecting switch ( C - D) or home bar door switch ( E - F).

# MICOM CIRCUIT DESCRIPTION

## 1-5. Temperature Detecting Circuit, Duct Door Heat Working Circuit

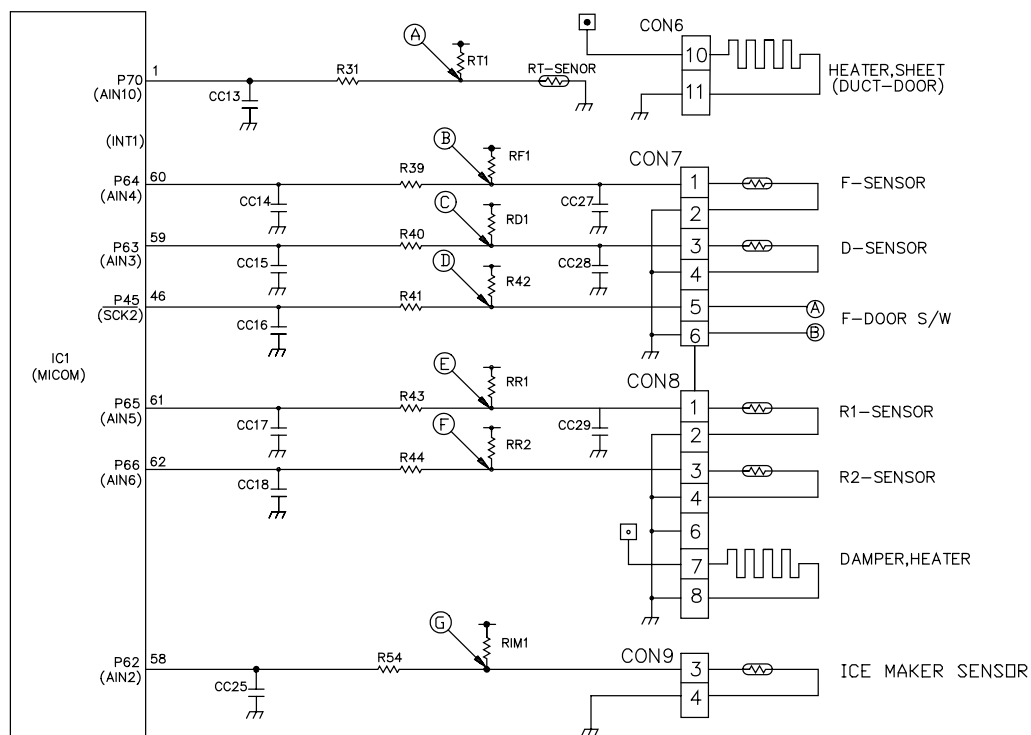

The above circuit is fixed in the freezer compartment sensor, refrigerator compartment sensor, ice making sensor, and defrost sensor. The condition of short or open of each temperature sensor is as follows.

SENSOR	CHECK POINT	NORMAL(-30 °C ~ 50 °C)	SHORT	OPEN
OPEN AIR SENSOR	POINT (A) Voltage	0.5 V~4.5 V	0 V	5 V
FREEZER SENSOR	POINT (B) Voltage			
DEFROST SENSOR	POINT (C) Voltage			
REFRIGERATOR SENSOR 1	POINT (E) Voltage			
REFRIGERATOR SENSOR 2	POINT (F) Voltage			
ICE MAKER SENSOR	POINT (G) Voltage			

\* 12 Vdc shall be applied to No. 10 and 11 terminals of CON6 as duct door heater is always on.

# MICOM CIRCUIT DESCRIPTION

## 1-6. Switch Input Circuits

The following circuit is an input circuit to detect the test switch for refrigerator detection and to detect the signal of electronic single motor damper reed switch.

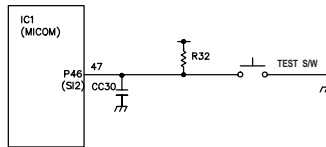

## 1-7. Option Designation Circuit (Model Classifying Function)

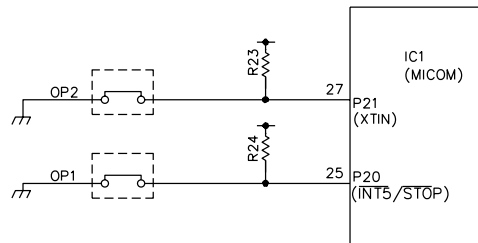

The above circuit is to designate model by option and inform it to MICOM. The option designation and application standard for each model is as follows.

Classification	Connection Conditions	Application Standard
OP1	Connection	Other area (Changable)
	Cut	Domestic
OP2	Connection	Model with dispenser
	Cut	Model without dispenser

► This circuit is fixed in the factory before shipment. Do not add or remove option at your discretion.

## 1-8. Stepping Motor Working Circuit

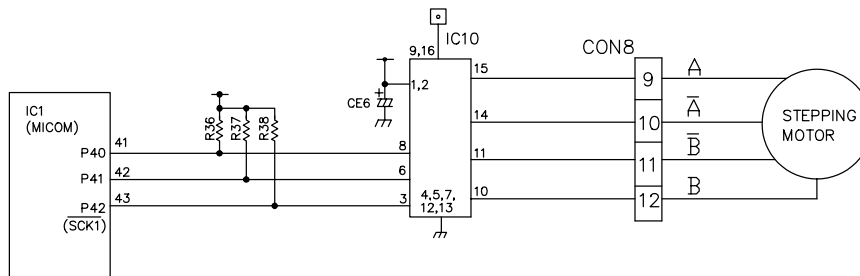

Motor rotates as rotating magnetic forms on the coils wound on each phase of stator when Micom pin No. 41 applies "High" signal to IC6 (TA774AP) and Micom pin No. 42 and 43 produces "High" and "Low" signals.

# MICOM CIRCUIT DESCRIPTION

Description) MICOM Pin No. 41, 42, and 43 terminals send signals of which wave form are shown on the right in 3.33 msec cycles. These signals pass through input terminals (No. 3, 6, and 8) of motor driving IC6 (TA7774AP) and are sent to the output terminal (No. 10, 11, 14, 15). These output signals form rotating magnetic on the coils wound on each phase of stator and motor rotates. When signals are input to INa and INb of motor driving IC (TA774AP), rotating magnetic forms on the coils wound on each phase of stator and stepping motor damper rotates.

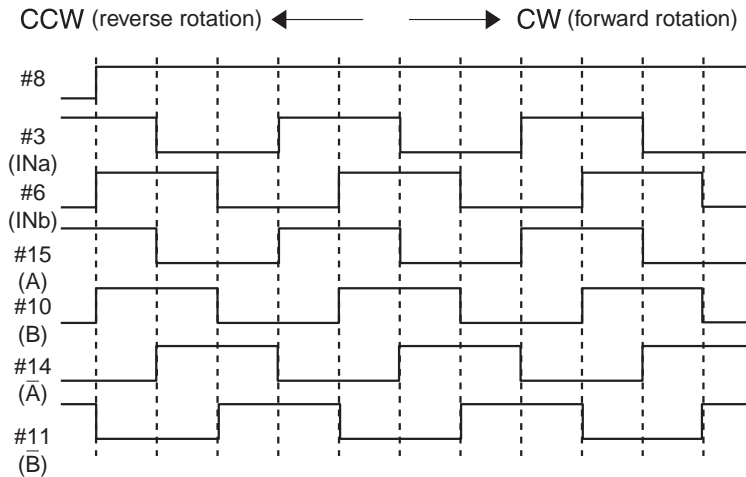

## 1-9. Temperature Compensation and Over Cooling/Weak Cooling Compensation Circuit

### 1. Freezer and refrigerator compartment temperature compensation

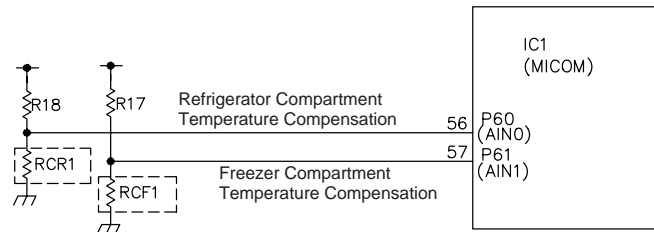

Freezer Compartment		Refrigerator Compartment		Remarks
Resistance value (RCF1)	Temperature Compensation	Resistance value (RCR1)	Temperature Compensation	
180 kΩ	+5 °C	180 kΩ	+2.5 °C	↑ Compensate to warm
56 kΩ	+4 °C	56 kΩ	+2.0 °C	
33 kΩ	+3 °C	33 kΩ	+1.5 °C	
18 kΩ	+2 °C	18 kΩ	+1.0 °C	
12 kΩ	+1 °C	12 kΩ	+0.5 °C	
10 kΩ	0 °C	10 kΩ	0 °C	Reference temperature
8.2 kΩ	-1 °C	8.2 kΩ	-0.5 °C	↓ Compensate to cool
5.6 kΩ	-2 °C	5.6 kΩ	-1.0 °C	
3.3 kΩ	-3 °C	3.3 kΩ	-1.5 °C	
2 kΩ	-4 °C	2 kΩ	-2.0 °C	
470 Ω	-5 °C	470 Ω	-2.5 °C	

- Temperature Compensation Table by Resistance Adjustment (the difference compared to the present temperature)  
 EX) The temperature of refrigerator increases by 1 °C if refrigerator compartment compensation resistance is changed from 10 kΩ to 18 kΩ.

# MICOM CIRCUIT DESCRIPTION

► Refrigerator compartment temperature compensation table is as shown below.

		Amended Resistance	470 Ω	2 kΩ	3.3 kΩ	5.6 kΩ	8.2 kΩ	10 kΩ	12 kΩ	18 kΩ	33 kΩ	56 kΩ	180 kΩ
		Present Resistance											
Refrigerator Compartment (RCR1)	470Ω	No change	0.5 °C Increase	1 °C Increase	1.5 °C Increase	2 °C Increase	2.5 °C Increase	3 °C Increase	3.5 °C Increase	4 °C Increase	4.5 °C Increase	5 °C Increase	
	2 kΩ	0.5 °C Decrease	No change	0.5 °C Increase	1 °C Increase	1.5 °C Increase	2 °C Increase	2.5 °C Increase	3 °C Increase	3.5 °C Increase	4 °C Increase	4.5 °C Increase	
	3.3 kΩ	1 °C Decrease	0.5 °C Decrease	No change	0.5 °C Increase	1 °C Increase	1.5 °C Increase	2 °C Increase	2.5 °C Increase	3 °C Increase	3.5 °C Increase	4 °C Increase	
	5.6 kΩ	1.5 °C Decrease	1 °C Decrease	0.5 °C Decrease	No change	0.5 °C Increase	1 °C Increase	1.5 °C Increase	2 °C Increase	2.5 °C Increase	3 °C Increase	3.5 °C Increase	
	8.2 kΩ	2 °C Decrease	1.5 °C Decrease	1 °C Decrease	0.5 °C Drop	No change	0.5 °C Increase	1 °C Increase	1.5 °C Increase	2 °C Increase	2.5 °C Increase	3 °C Increase	
	10 kΩ	2.5 °C Decrease	2 °C Decrease	1.5 °C Decrease	1 °C Decrease	0.5 °C Decrease	No change	0.5 °C Increase	1 °C Increase	1.5 °C Increase	2 °C Increase	2.5 °C Increase	
	12 kΩ	3 °C Decrease	2.5 °C Decrease	2 °C Decrease	1.5 °C Decrease	1 °C Decrease	0.5 °C Decrease	No change	0.5 °C Increase	1 °C Increase	1.5 °C Increase	2 °C Increase	
	18 kΩ	3.5 °C Decrease	3 °C Decrease	2.5 °C Decrease	2 °C Decrease	1.5 °C Decrease	1 °C Decrease	0.5 °C Decrease	No change	0.5 °C Increase	1 °C Increase	1.5 °C Increase	
	33 kΩ	4 °C Decrease	3.5 °C Decrease	3 °C Decrease	2.5 °C Decrease	2 °C Decrease	1.5 °C Decrease	1 °C Decrease	0.5 °C Decrease	No change	0.5 °C Increase	1 °C Increase	
	56 kΩ	4.5 °C Decrease	4 °C Decrease	3.5 °C Decrease	3 °C Decrease	2.5 °C Decrease	2 °C Decrease	1.5 °C Decrease	1 °C Decrease	0.5 °C Decrease	No change	0.5 °C Increase	
	180 kΩ	5 °C Decrease	4.5 °C Decrease	4 °C Decrease	3.5 °C Decrease	3 °C Decrease	2.5 °C Decrease	2 °C Decrease	1.5 °C Decrease	1 °C Decrease	0.5 °C Decrease	No change	

- Temperature adjustment of refrigerator compartment is conducted by the same way as that of refrigerator. The temperature compensation of freezer is twice of refrigerator.
- This circuit is to input the degree of temperature compensation to MICOM in order to adjust the temperature of refrigerator.

# MICOM CIRCUIT DESCRIPTION

## 2. Refrigerator Weak Cooling and Over Cooling Compensation Circuit

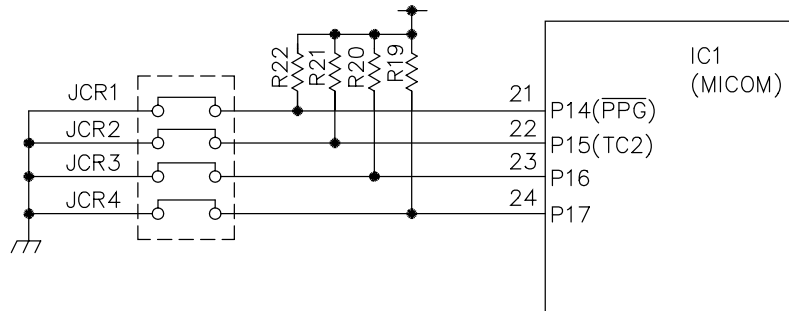

Temperature Compensation by Cutting		
JCR1	+1 °C	+2 °C
JCR2	+1 °C	
JCR3	-1 °C	-2 °C
JCR4	-1 °C	

WEAK COOLING COMPENSATION		OVER COOLING COMPENSATION		REFRIGERATOR COMPARTMENT TEMPERATURE COMPENSATION	REMARKS
JCR3	JCR4	JCR1	JCR2		
				0 °C (FACTORY SHIPPING)	
CUT				-1 °C	
	CUT			-1 °C	
		CUT		+1 °C	
			CUT	+1 °C	
CUT	CUT			-2 °C	
		CUT	CUT	+2 °C	
CUT		CUT		0 °C	
	CUT	CUT		0 °C	
	CUT		CUT	0 °C	
CUT	CUT	CUT		-1 °C	
	CUT	CUT	CUT	+1 °C	
CUT	CUT	CUT	CUT	0 °C	

- The above option circuit is to compensate the refrigerator compartment temperature by cutting during service.



# MICOM CIRCUIT DESCRIPTION

## 1-10. Key Button Input and Display Lighting Circuit

### 1. GR-P247, GR-P207, GR-L247, GR-L207

This circuit is to judge the work of function control button on the operation panel and to light each function indication led (LED module). It is driven by SCAN method.

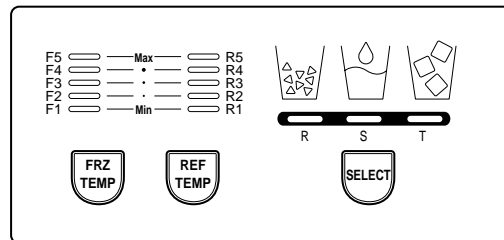
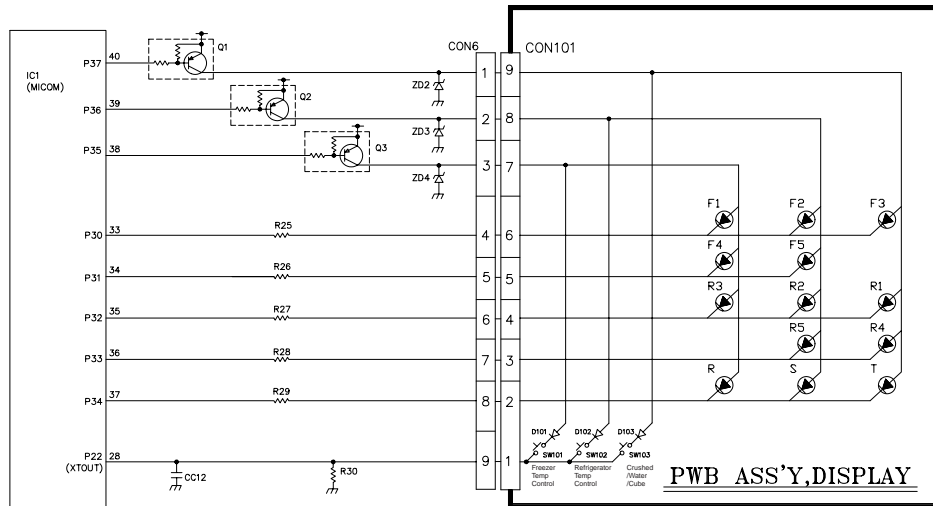

### 2. GR-C247, GR-C207, GR-B247, GR-B207, GR-B197

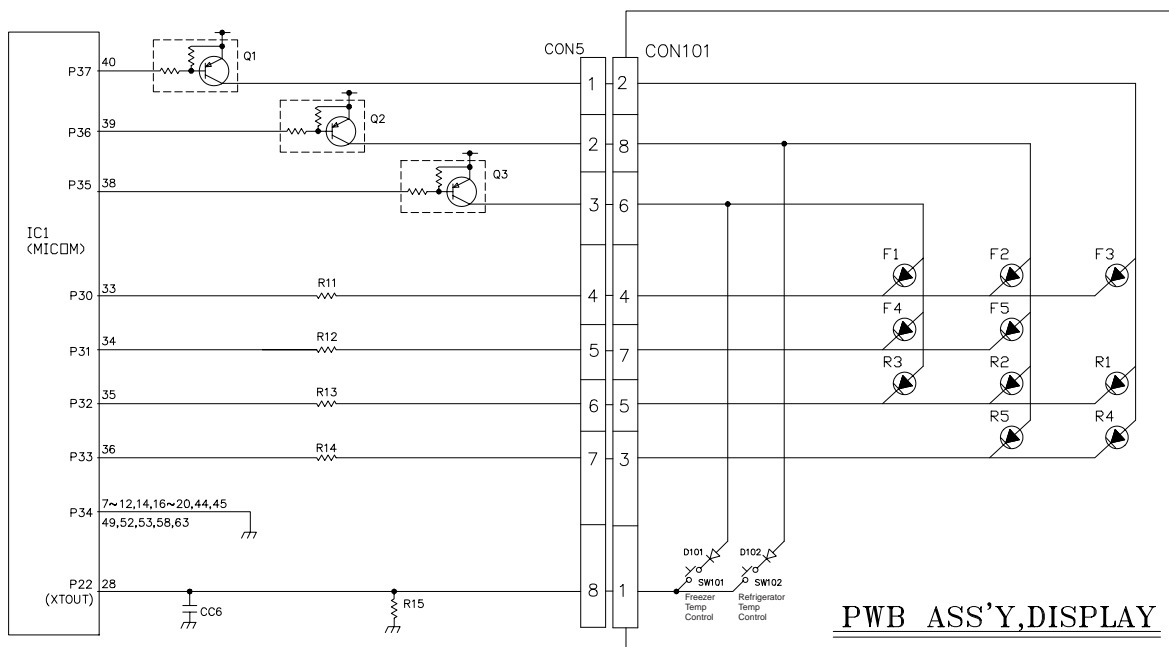

# MICOM CIRCUIT DESCRIPTION

---

## 2. Sensor Resistance Characteristic Table

Measured Temperature (°C)	Freezer Sensor	Refrigerator Sensor 1 and 2, Defrost Sensor and Open Air Sensor
-20 °C	22.3 kΩ	77 kΩ
-15 °C	16.9 kΩ	60 kΩ
-15 °C	13.0 kΩ	47.3 kΩ
-5 °C	10.1 kΩ	38.4 kΩ
0 °C	7.8 kΩ	30 kΩ
+5 °C	6.2 kΩ	24.1 kΩ
+10 °C	4.9 kΩ	19.5 kΩ
+15 °C	3.9 kΩ	15.9 kΩ
+20 °C	3.1 kΩ	13 kΩ
+25 °C	2.5 kΩ	11 kΩ
+30 °C	2.0 kΩ	8.9 kΩ
+40 °C	1.4 kΩ	6.2 kΩ
+50 °C	0.8 kΩ	4.3 kΩ

- Tolerance of sensor resistance is  $\pm 5\%$ .
- Leave the sensor at measuring temperature for more than 3 minutes when measuring sensor resistance. (necessary due to detecting speed)
- It is desirable to use digital tester as analogue tester has wider measuring temperature.
- Disassemble refrigerator sensor 1 and 2 from CON8 of main PWB assembly and measure it with digital tester.
- Disassemble freezer sensor from CON7 of main PWB assembly and measure it with digital tester.

# MICOM CIRCUIT DESCRIPTION

## 3. PWB Parts Drawings and List

### 3-1. PWB Assembly Main Parts Drawings

1 GR-P247, GR-P207, GR-L247, GR-L207

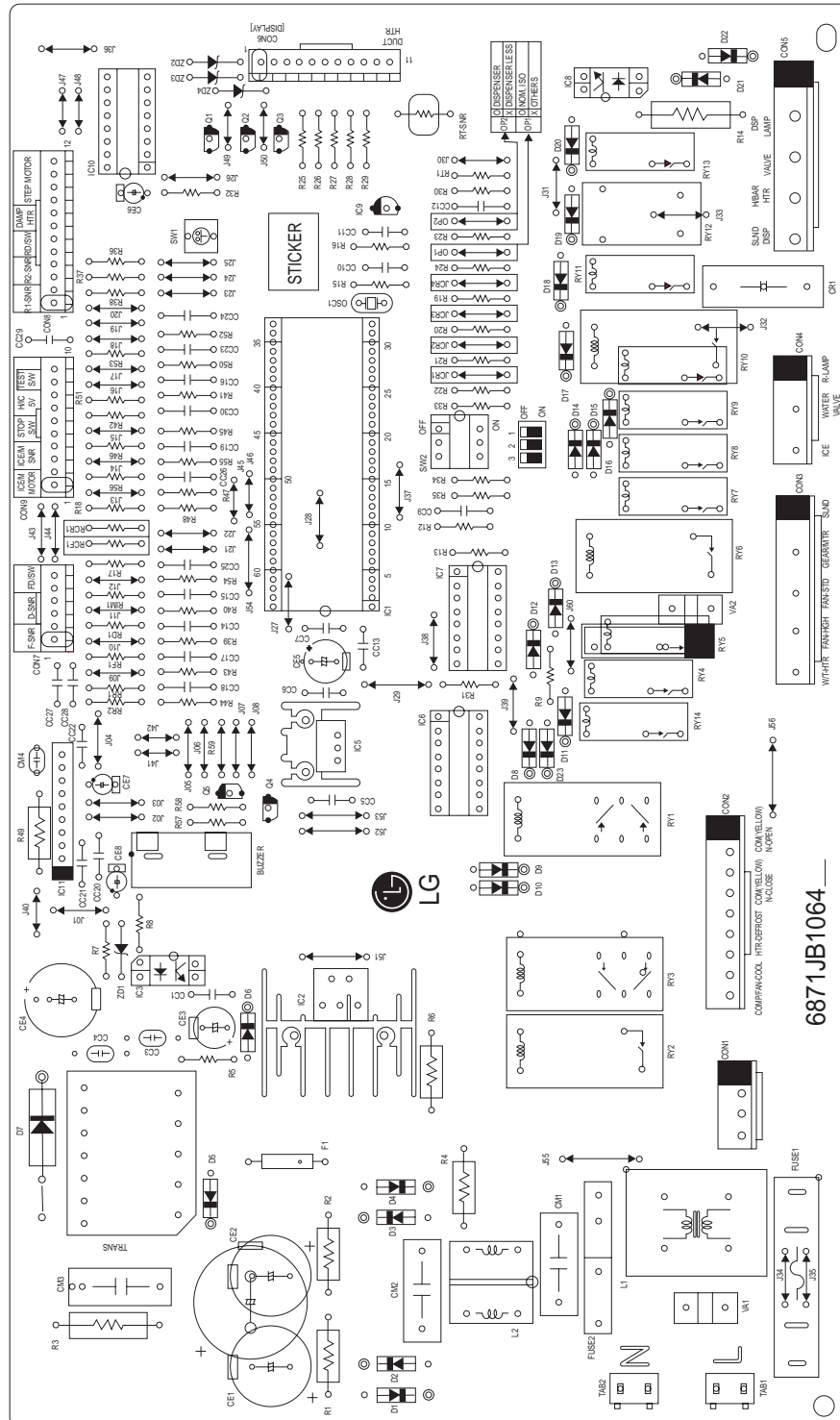



# MICOM CIRCUIT DESCRIPTION

## 3-2. Parts List

### 1. GR-P247, GR-P207 / GR-L247, GR-L207

GR-L247/207	GR-P247/207	WORK	QTY.	QTY.	NO.	DWG. NO.	DESCRIPTION	SPEC'	MAKER	REMARK
			1	1	1	6870.B2032A	PWB,MAIN	FR-(DS-1107A)	DOO SAN	t=1.6
			1A	1A	2	6170.B2007	TRANS,SMP(S(COIL))		UNION	TRANS
			1	1	3	6630.B8001G		JE202-1T-04		CON1
			1	1	4	6630.B8001Y		JE202-1T-09		CON2
			1	1	5	6630.B8001B		JE202-1T-03(SP-24)		CON4
					6				JAE EUN	
			1	1	7	6630.B8001D		JE202-1T-05(SP-24.6A)		CON3(RE.D)
					8					
			1	1	9	6630.B8001D		JE202-1T-05(SP-24.6A)		CON5
					10					
			1	1	11	6630.B8004E		SMW250-06		CON7
			1	1	12	6630.B8004J		SMW250-10	YEON HO	CON9
			1	1	13	6630.B8004L		SMW250-12		CON8
			1	1	14	6630.B8004K		SMW250-11		CON6
			1	1	15	D1ZZJB2003C	MICOM CHIP	TMP87C841N	TOSHIBA	IC1(=O1ZZJB2003C)
						D1ZZJB2003E		TMP87C841N		IC1(=O1ZZJB2003E)
						01NE780050A	REGULATOR	KIA78005AP	K.E.C	
			1	1	16	01RH178050B		BA17805T	ROHM	IC5
			1	1	17	01KD010100A	RESET IC	BMRO101D	KODENSHI	IC9
			2	2	18	01KE650030B	DRIVE IC	KID65003AP	K.E.C	IC6,7
			1	1	19	01T0777400A	DRIVE IC	TA7774AP	TOSHIBA (JAPAN)	IC10
			1	1	20	01RH622200A	DRIVE IC	BA6222	ROHM	IC11
			1	1	21	01SK615300A	DRIVE IC	STR-G6153T	SANKEN	IC2
					22					
			1	1	23	01T0721000A	PHOTO TR	TLP721	TOSHIBA	IC3 IC8
			1	1	24	J510-00005A		G2R-1A-E	OMRON	
			1	1	25	6920.B2005A		JW10FHN	NAIS	RY6
						6920.B2002A		VS-12MB	TAKAMISAWA	
			1	1	26	6920.B2005A		JW10FHN	NAIS	RY2
						6920.B2004A		DH12DI-O-C	JAEIL	
			2	2	27	6920.B2007A		VSB-12TB	TAKAMISAWA	RY1,3
			1	1	28	6920.B2003A		G5N-1A	OMRON	RY5
			6	6	29	6920.B2003A		G5N-1A	OMRON	RY4,7,8,9 RY11,13 RY14
			1	1	30	6920.B2003A		G5N-1A	OMRON	RY10
					31	6920.B2004A		DH12DI-O-C	JAEIL	(R-LAMP)
					32	6920.B2006B		UT205-12SC	YUYU	RY12(H/BAR)
			1	1	33	6212A09002B	RESONATOR	CST4.00MGW	MURATA	OSC1 (=6212A09002B)
						J570-00012B		CST4.00MGW-1F01		
			1	1	34	6102.B8001B		INR14D621	IL JIN	VA1
					35	J572-00001D	VARIATOR	INR14D271	IL JIN	VA1
					36	6102A09075E		INR10D471	IL JIN	VA2
			1	1	37	0DR107009AA		FR107		D5
			1	1	38	0DR302000BA	FAST RECOVER D	FR302	DELTA	D7
					39					
			5	5	40	00D400409AC	RECTIFIER DIODE	1N4004	DELTA	D8~10,13,17
			5	5	41	00D400709AB		1N4007		D1~4,22
			1	1	42					D12
			8	8	43	00D414809BB	SWITCHING DIODE	1N4148	ROHM	D6,11,14,15 16,18,20,21 D17(H/LAMP) D23
			1	1	44	00Z152419AA	ZENER DIODE	1N5241B/11V	DELTA	ZD1

GR-L247/207	GR-P247/207	WORK	QTY.	QTY.	NO.	DWG. NO.	DESCRIPTION	SPEC'		REMARK
			1	1	45	0CE2271F638		220uF/16V		CE5
			1	1	46	0CE687AH690		680uF/25V RX TYPE		CE4
			1	1	47	0CE1071H638		100uF/25V		CE7
			1	1	48	0CE4761H638		47uF/25V		CE8
			1	1	49	0CE1061K638		1uF/50V	SAM HWA RUBYCON	CE6
			1	1	50	0CE4761K638		47uF/50V		CE3
			1	1	51	0CE686AR630		68uF/250V RX TYPE		CE1,CE2
			1	1	52	0CE476AK638		47uF/450V HE TYPE		CE2
			1	1	53	0CC4732Y430		47.3/6.30V		CM3
			1	1	54	0CC2231N409		223/100V	SEIL	CM4
			1	1	55	0CK1020K519		102/50V		CC12
			6	6	56	0CK1040K919		104/50V		CC5~7,9~11
			18	18	57	0CK4710K519		471/50V	TAE YANG	CC13~30
					58					
					59					
					60					
					61					
			1	1	62	0CC10418670		104/275V	PILKOR	CM2
			1	1	63	0CC10418670		104/275V		CM1
			2	2	64	0CK22102510		221/2KV	SAM HWA	CC3,4
					65	0RS2701K600		2.7K /2W		
					66	0RS4702K600		47K/2W		
			2	2	67	0RS5602K600		56K /2W		R3,14
					68	0RS0151J609		1.5 /1W		
					69	0RS8202J609		82K /1W		R4
			1	1	70	0RS1503J609		150K /1W		R4
			1	1	71	0RD0221H609		2.2 1/2W		R6
			1	1	72	0RD0682H609		68J 1/2W		R49
					73	0RD2003H609		200K 1/2W		R1
					74	0RD2003H609		200K 1/2W		R2
			1	1	75	0RD5603H609		560K 1/2W		R2
			1	1	76	0RD0222G609		22 1/4W		R5
			1	1	77	0RD1000G609		100 1/4W		R13
			5	5	78	0RD1800G609		180J 1/4W		R25~R29
			1	1	79	0RD2000G609		220 1/4W		R57
					80	0RD6200G609		620 1/4W		R9
			1	1	81	0RD1001G609		1K 1/4W		R58
			1	1	82	0RD1201G609		1.2K 1/4W		R8
			1	1	83	0RD1801G609		1.8K 1/4W		R7
			9	9	84	0RD2001G609		2K 1/4W	(1)CHOYANG (2)SMART	R31,39~46 R50,52~56
			11	11	85	0RD4701G609		4.7K 1/4W		R16,19~24,32~35 R47,48,51,59
			4	4	86	0RD1002G609		10K 1/4W		R12,17,18 R30,36~38
			3	3	87	0RD1004G609		1M 1/4W		R15
			4	4	88	0RD1002G609		10K 1/4W		RCF1
			1	1	89	0RD1002G609		10K 1/4W		RCR1
					90	0RD0101J609		1 / 1 V		R6
					91					
					92					
					93					
					94					
					95					
			1	1	96	0RN1002G409		10KF 1/4W		RT1
			2	2	97	0RN1622G409		16.2KF 1/4W		RF1,RIM1
			3	3	98	0RN2612G409		26.1KF 1/4W		RD1,RR1,2

# MICOM CIRCUIT DESCRIPTION

## 1. GR-P247, GR-P207, GR-L247, GR-L207

GR-L247/207		GR-P247/207		WORK							
QTY.	QTY.	No.	DWG. NO.	DESCRIPTION	SPEC'					REMARK	
1	1	99	0TR106009AC	TRANSISTOR	KTA106M	K.E.C				Q4	
1	1	100	0TR106009AF		KTC106M					Q5	
1	1	101	6908JB3002A	BUZZER,PIZO CE	BM-20K	BUJEON				BUZZER	
1	1	102	6210JB8001A	CORE(CRC),HEADS	BFS3510A0	SAM HWA				F1	
1	1	103	6600JB8001A	TEST S/W	SKHV10910	LG				SW1	
1	1	104	6600JB8003A	DIP S/W	3P,DIP	OTAX				SW2	
10	10				0.6X7.5mm					J40~49	
34	34									J01~31,36~37,60	
										J32(R-LAMP)	
										J33(H/BAR)	
1	1	105	43607015	JUMP WIRE	0.6X10mm					J34,35(FUSE1)	
1	1									FUSE2	
1	1									JCR1	
1	1									JCR2	
1	1									JCR3	
1	1									JCR4	
1	1									OP1	
1	1									OP2	
1	1									R9	
7	7				0.6X12.5mm					J50~56	
1	1									R1	
1	1	106	6200JB8001A	RC FILTER	0.1uF+120/250VAC	PILKO				CR1	
1	1	107	4920JB3007A	HEAT SINK(STR)							
1	1	108	4920JB3001A	HEAT SINK(SV)	(=J572-00002A)						
1	1	109	6200JB3004A		2mH	TNC				L1	
		110								L1	
1	1	111	6200JB3005A	COMMON COIL	32mH	UNION				L2	
		112								L2	
		113									
1	1	114	3J02447C	FUSE	15A/250V					FUSE1	
2	2	115	6901JB8001A	FUSE HOLDER	FC61F	SAM JU					
		116	0FZZJB3001A	FUSE	2A/250V					FUSE2	
		117									
2	2	118	0Q01030F	250 TAB	GP881191-2	K.E.T				TAB1,2	
2	2	119	1SBF0302418	SCREW	ASSY H/SINK	TAE SUNG					
3.0g	3.0g	120	49111001	SOLDER	ALMIT KR-19RMA	DAE JIN					
25g	25g	121	49111004	SOLDER LEAD BAR	H63A						
1.5g	1.5g	122	59333105	FLUX AUTO	JS71	KOKI					
3	3	123	0TR226009AB	TRANSISTOR	KRA226M	K.E.C				Q1~Q3	
1	1	124	6500JB3001A	SENSOR	PBN-43	JAMES TEC				RT-SNR	
3	3	125	0DZ152349AA	ZENER DIODE	1N5234B	DELTA				ZD2~ZD4	
2	2	126	43607015	JUMP WIRE	0.6*10mm					J38,39	

# MICOM CIRCUIT DESCRIPTION

## 2. GR-C247, GR-C207, GR-B247, GR-B207, GR-B197

NO.	DWG. NO.	DESCRIPTION	SPEC'	MAKER	REMARK	NO.	DWG. NO.	DESCRIPTION	SPEC'	MAKER	REMARK	NO.	DWG. NO.	DESCRIPTION	SPEC'	MAKER	REMARK		
1	6870JB2031A	PWB,MAIN	FR-1(0S-1107A)	1 DOO SAN	t=1.6	34		0CE2286J618	2200uF/35V	1	CE1	73	0TR106009AC	TRANSISTOR	KTA106M	4	K.E.C	Q1~Q4	
2	6170JB2002H	TRANS	JE202-11-02	1 TAE SUNG	TRANS	35		0CE1081H618	1000uF/25V	1	CE2	74	0TR106009AF	TRANSISTOR	KTC106M	1		Q5	
3	6630JB8001X		JE202-11-02(3P-2)	1	CON1	36		0CE4771H618	470uF/25V	1	CE3	75	6908JB3002A	BUZZER/PIZO Q	BM-20K	1	BUJEON	BUZZER	
4	6630JB8001A		JE202-11-02(3P-2)	1	CON4							76	6806JB8001A	250 TAB	881206-2	2	KET	TAB1,2	
5	6630JB8001B		JE202-11-02(3P-2)	1 JAE EUN	CON3	37		0CE2271F638	220uF/16V	1	SAM HWA RUBYCON	CE5							
6	6630JB8001Q		JE202-11-11	1	CON2	38		0CE4761H638	47uF/25V	1		CE7							
7						39		0CE1051K638	1uF/50V	1		CE6							
8	6630JB8004E	WAFER	SMW250-06	1	CON6	40													
9	6630JB8004J		SMW250-10	1 YEON HO	CON5	41		0CQ2231N409	223/100V	2	SAM HWA	CM1,2	78	6901JB8001A	FUSE HOLDER	FC61F	2		
10	6630JB8004L		SMW250-12	1	CON7	42		0CK1020K519	102/50V	1		CC6	79	3J02447C	FUSE	15A/250V	1	SAM JU	FUSE
11						43		0CK2230K949	223/50V	7	TAE YANG	CC7~CC13							
12	01Z2JB2003C	MICOM CHIP	TMP87C841N	1 TOSHIBA	IC1(=01Z2JB2003D)	44		0CK1040K919	104/50V	5		CC1~CC5	80		0.6x7.5mm	2		J19,20	
13	01RH178050B	REGULATOR	BA17805T	1 ROHM	IC3			0RD1803G609	180K 1/4W									J29(R-LAMP)	
	01KE780050A	REGULATOR	KIA78005AP	1 K.E.C	IC3			0RD5602G609	56K 1/4W									J01~J18	
14	01KD010100A	RESET IC	EMR0101D	1 KODENSHI	IC5	45		0RD3302G609	33K 1/4W									J25, J26	
15	01KE650030B	DRIVE IC	KID65003AP	1 K.E.C	IC4			0RD1802G609	18K 1/4W									J28(H/BAR)	
16	01O6278330A	DRIVE IC	TD62783AP	1 TOSHIBA (JAPAN)				0RD1202G609	12K 1/4W									OP1	
17	01MI545630A	DRIVE IC	M54563P	1 MITSUBISHI				0RD1002G609	10K 1/4W	1								OP2	
18	01O620833A	DRIVE IC	KID65083AP	1 K.E.C				0RD8201G609	8.2K 1/4W									JCR1	
19	01O620833A	DRIVE IC	TD62083AP	1 TOSHIBA				0RD5601G609	5.6K 1/4W									JCR2	
20	01O777400A	DRIVE IC	TA7774AP	1 TOSHIBA (JAPAN)	IC6			0RD2001G609	20K 1/4W									JCR3	
21	01RH178120A	REGULATOR	BA17812T	1 ROHM	IC2	46		0RD4700G609	470 1/4W									JCR4	
22	6920JB2005A	RELAY	JW1oFHN	2 NAIS	RY2,RY3			0RD1803G609	180K 1/4W									J21~24	
23	6920JB2002A		VS-12MB	2 TAKAMISIMA				0RD5602G609	56K 1/4W										
24	6920JB2004A		DH12DI-O-Q	1 JAEIL	RY2			0RD3302G609	33K 1/4W										
25	6920JB2003A		G5N-1A	2 OMRON	RY4,5			0RD1802G609	18K 1/4W										
26	6920JB2006B		G5N-1A	1 OMRON	RY6			0RD1202G609	12K 1/4W										
27	6920JB2001Z	RESONATOR	UT205-12SC	1 YUYU	RY7			0RD1002G609	10K 1/4W	1									
28	6920JB2001Z	RESONATOR	CST4.00MGW	1 MURATA	OSC1(=6212A09002B)			0RD8201G609	8.2K 1/4W										
29	6920JB2001Z	RESONATOR	CST4.00MGW-TF01	1 MURATA				0RD5601G609	5.6K 1/4W										
30	6920JB2001Z	VARIATOR	SVC471D14A	1 SAMHWA	VA1	59		0RD3301G609	3.3K 1/4W										
31	6920JB2001Z	VARIATOR	INR14D471	1 IL JIN		60		0RD2001G609	20K 1/4W	9									
32	6920JB2001Z	VARIATOR	SVC621D14A	1 SAMHWA		61													
33	6920JB2001Z	VARIATOR	INR14D621	1 IL JIN		62													
34	6920JB2001Z	VARIATOR	SVC271D14A	1 SAMHWA		63													
35	6920JB2001Z	VARIATOR	INR14D271	1 IL JIN		64		0RD4701G609	4.7K 1/4W	9									
36	6920JB2001Z	VARIATOR				65													
37	6920JB2001Z	VARIATOR				66													
38	6920JB2001Z	VARIATOR				67		0RD1002G609	10K 1/4W	6									
39	6920JB2001Z	VARIATOR				68		0RD1004G609	1M 1/4W	1									
40	6920JB2001Z	VARIATOR				69													
41	6920JB2001Z	VARIATOR				70		0RN1622G409	16.2KF 1/4W	1									
42	6920JB2001Z	VARIATOR				71		0RN2612G409	26.1KF 1/4W	3									
43	6920JB2001Z	VARIATOR				72		0RN1002G409	10KF 1/4W	1									

# MICOM CIRCUIT DESCRIPTION

4. PWB circuit drawing- PWB circuit drawing may change depending on the conditions.

1 GR-P247, GR-P207,  
GR-L247, GR-L207

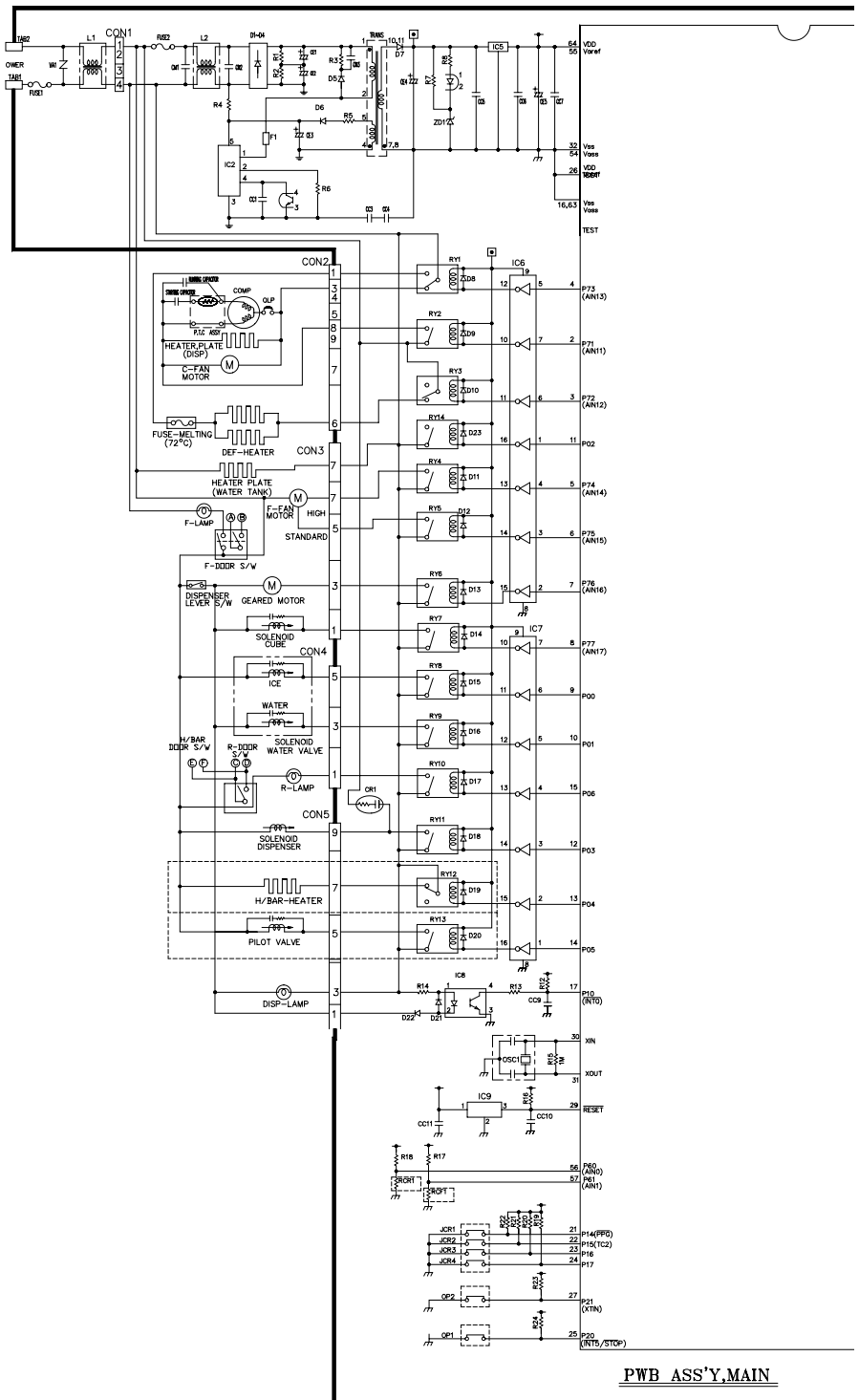



# MICOM CIRCUIT DESCRIPTION

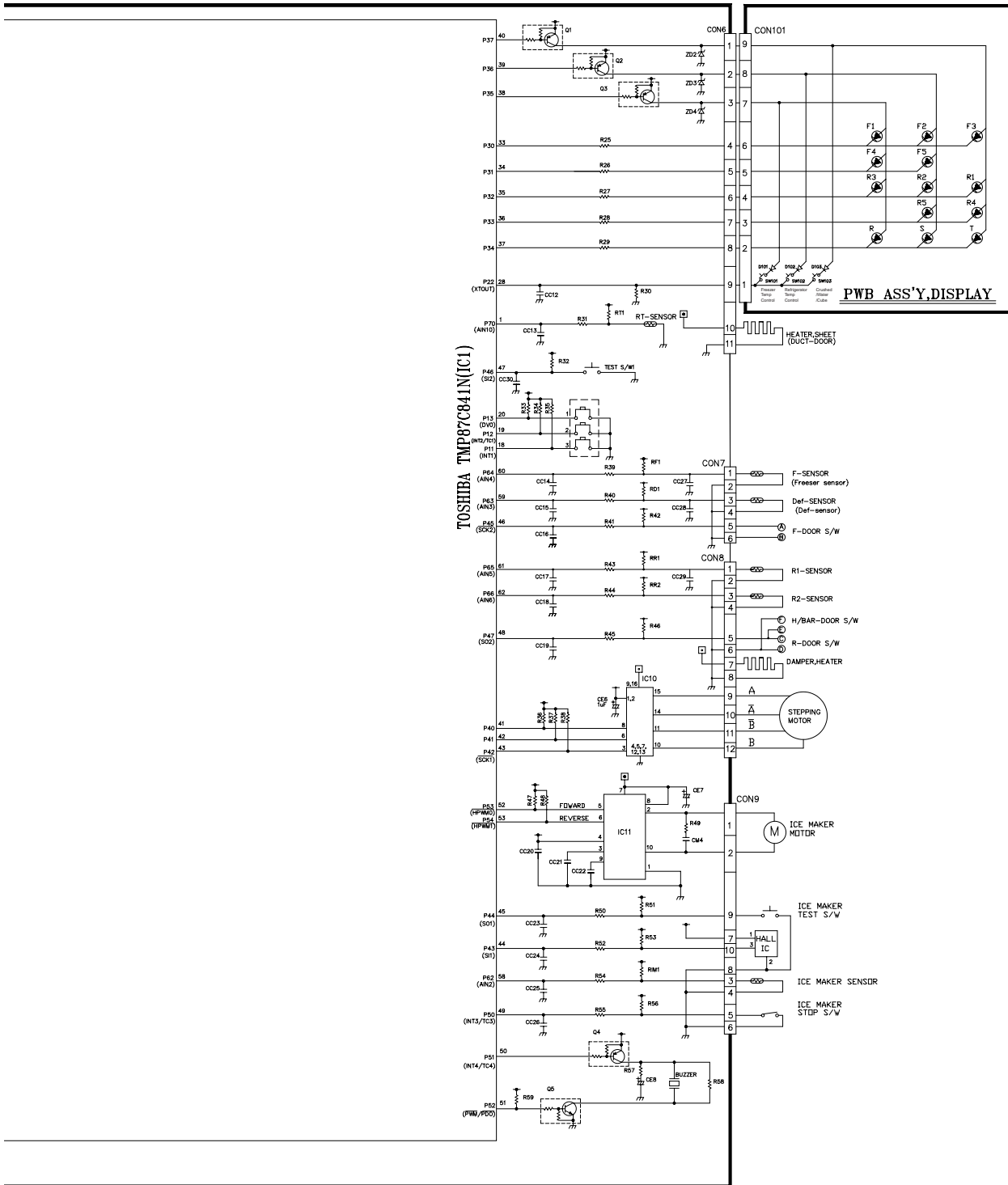

# MICOM CIRCUIT DESCRIPTION

## 2. GR-C247, GR-C207, GR-B247, GR-B207, GR-B197

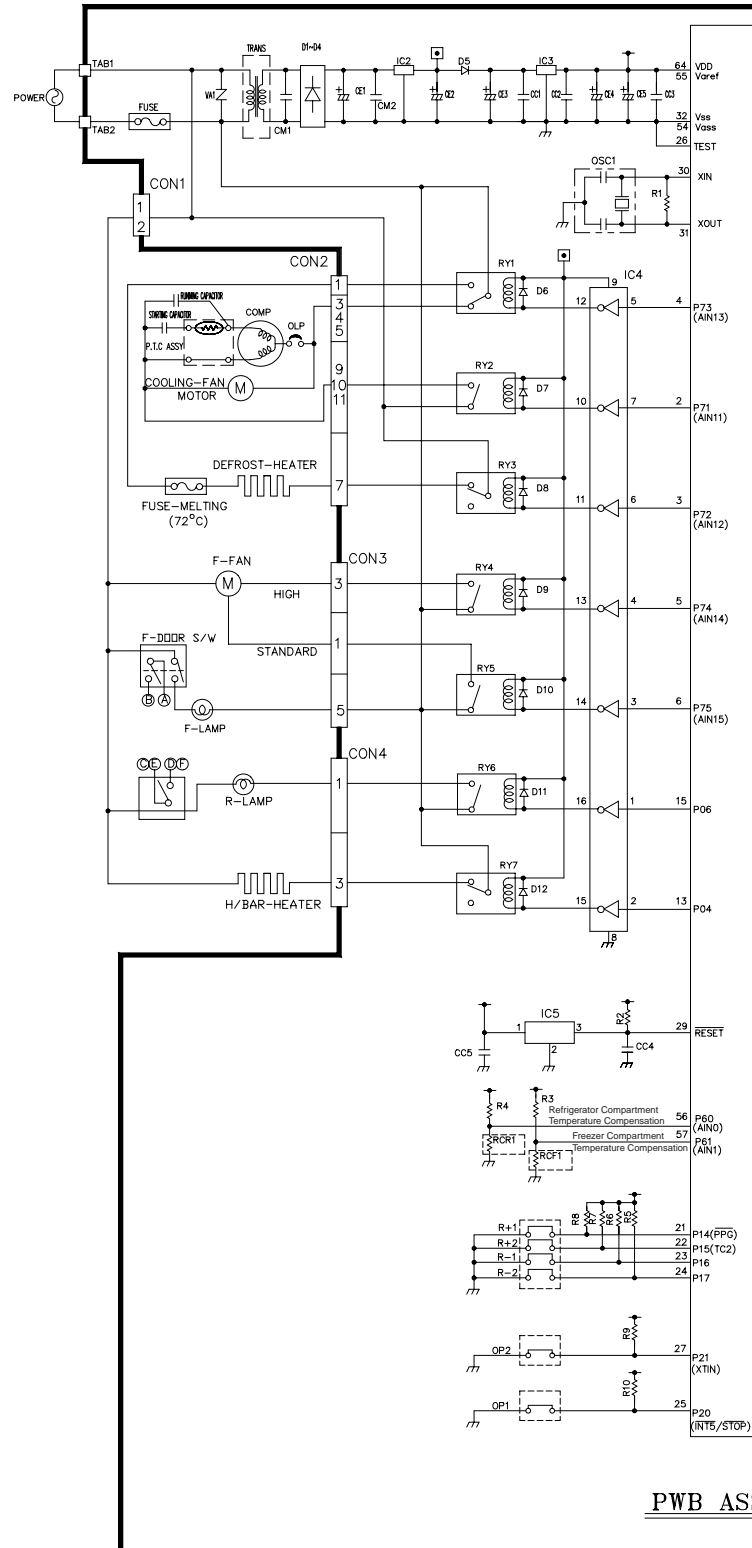



# ICE MAKER AND DISPENSER WORKING PRINCIPLES AND REPAIR

## 1. Working Principles

### 1-1. Ice Maker Working Principles

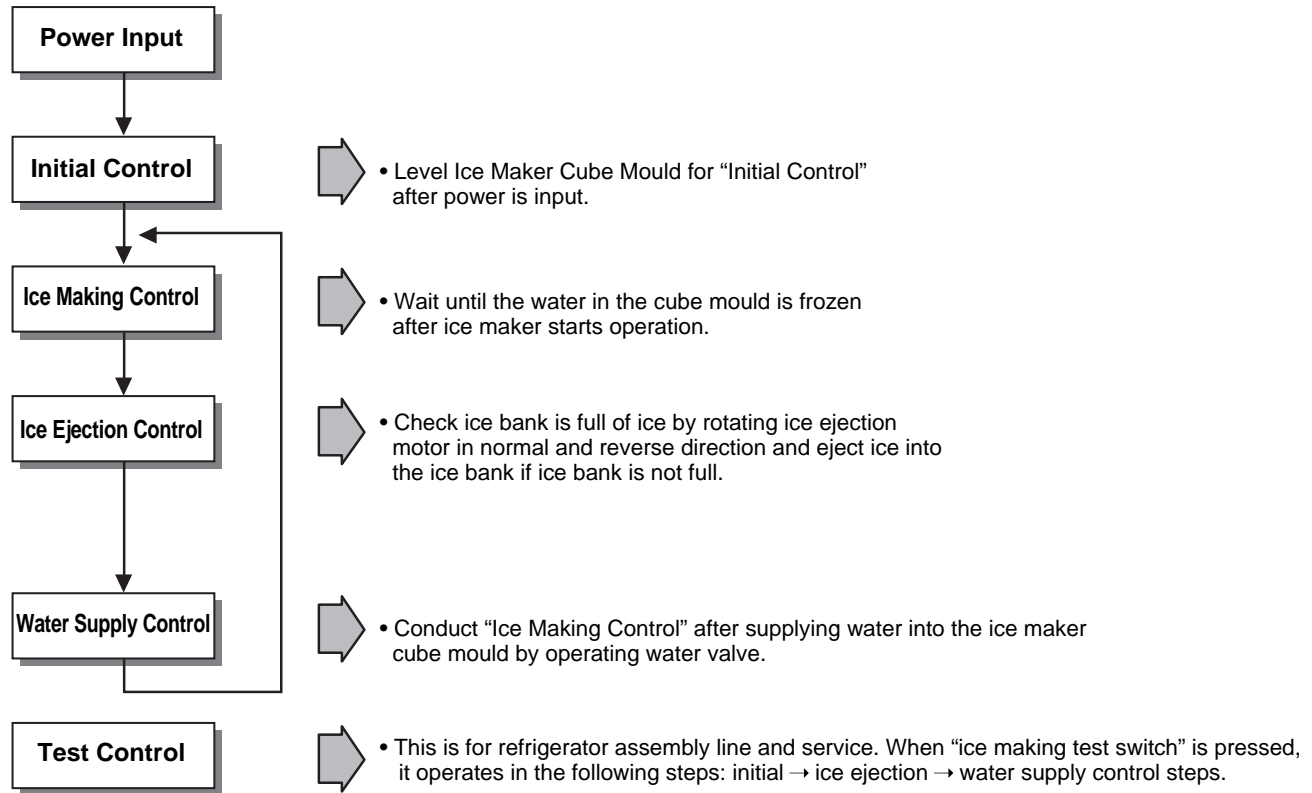

### 1-2. Dispenser Working Principles

1. This function is available in Model GR-P247, GR-P207 and GR-L247, GR-L207 where water and ice are available without opening freezer compartment door.
2. "Crushed Ice" is automatically selected when power is initially applied or reapplied after power cut.
3. When dispenser selection switch is continuously pressed, light is on in the following sequence: "Water" → "Cube Ice" → "Crushed Ice".
4. Lamp is on when dispenser rubber button is pressed and vice versa.
5. When dispenser crushed ice rubber button is pressed, dispenser solenoid and geared motor work so that crushed ice can be dispensed if there is ice in the ice bank.
6. When dispenser cube ice rubber button is pressed, dispenser solenoid, cube ice solenoid and geared motor work so that cube ice can be dispensed if there is ice in the ice bank.
7. When dispenser water rubber button is pressed, water valve opens and water is supplied if water valve is normally installed on the right side of the machine room.
8. Ice and water are not available when freezer door is open.

# ICE MAKER AND DISPENSER WORKING PRINCIPLES AND REPAIR

## 2. Function of Ice Maker

### 2-1. Initial Control Function

1. When power is initially applied or reapplied after power cut, it detects level of ice maker cube mould after completion of MICOM initialization. The detecting lever moves up and down.
2. The level of ice maker cube mould is judged by output signal, high and low signal, of Hall IC. Make the cube mould to be horizontal by rotating ice ejection motor in normal or reverse direction so that High/Low signal can be applied to MICOM Pin No. 44.
3. If there is no change in signals one minute after the geared motor starts to operate, it stops icemaker operation and check the signal every hour. It resets initialization of icemaker when it becomes normal.
4. It judges that the initial control is completed when it judges the ice maker cube mould is horizontal.
5. Ice ejection conducts for 1 cycle irrespective of ice in the ice bank when power is initially applied.

### 2-2. Water Supply Control Function

1. This is to supply water into the ice maker cube mould by operating water valve in the machine room when ice ejection control is completed and ice maker mould is even.
2. The quantity of water supplied is determined by DIP switch and time.

#### <Water Supply Quantity Table>

No	DIP SWITCH SETTING			WATER SUPPLY TIME	REMARKS
	S/W 1	S/W 2	S/W 3		
1	OFF	OFF	OFF	6.5 Sec.	* The quantity of water supplied depends on DIP switch setting conditions and water pressure as it is a direct tap water connection type. (the water supplied is generally 80 cc to 120 cc) * DIP switch is on the main PWB.
2	ON	OFF	OFF	5.5 Sec.	
3	OFF	ON	OFF	6 Sec.	
4	ON	ON	OFF	7 Sec.	
5	OFF	OFF	ON	7.5 Sec.	
6	ON	OFF	ON	8 Sec.	
7	OFF	ON	ON	9 Sec.	
8	ON	ON	ON	10 Sec.	

3. If water supply quantity setting is changed while power is on, water supplies for the amended time. If DIP switch is changed during water supply, water shall be supplied for the previous setting time. But it will supply for the amended time from the next supply.
4. When water supply signal is applied to water and ice valves at the same time during water supply, water shall be supplied to water valve. If water supply signal is applied to ice valve during water supply, water shall be supplied to both water and ice valves.

### 2-3. Ice Making Control Function

1. Ice making control is carried out from the completion of water supply to the completion of ice making in the cube mould. Ice making sensor detects the temperature of cube mould and completes ice making. (ice making sensor is fixed below ice maker cube mould)
2. Ice making control starts after completion of water supply control or initial control.
3. It is judged that ice making is completed when ice making sensor temperature reaches at -8°C after 100 minutes when water is supplied to ice maker cube mould.
4. It is judged that ice making is completed when ice maker sensor temperature reaches below -12 °C after 20 minutes in condition 3.

# ICE MAKER AND DISPENSER WORKING PRINCIPLES AND REPAIR

## 2-4. Ice Ejection Control Function

1. This is to eject ice from ice maker cube mould after ice making is completed.
2. If Hall IC signal is on within 3.6 seconds after ice ejection motor rotates in normal direction, it does not proceed ice ejection but waits. If the ice bank is full, ice ejection motor rotates in normal direction in every hour to check the condition of ice bank. If the ice bank is not full, the water supply control starts after completion of ice ejection control. If the ice bank is full, ice ejection motor rotates in reverse direction and sops under ice making or waiting conditions.
3. If ice bank is not full, ice ejection starts. The cube mould tilts to the maximum and ice is separated from the mould and ice checking lever raises.
4. Ice ejection motor stops for 1 second if Hall IC signal changes from OFF (low) to ON (high) after 3.6 seconds when ice ejection motor rotates in normal direction. If there is no change in Hall IC signals within 1 minute after ice ejection motor operates, ice ejection motor stops as ice ejection motor or hall IC is out of order.
5. If ice ejection motor or Hall IC is abnormal, ice ejection motor rotates in normal direction to exercise initial operation. It resets the ice maker if ice ejection motor or Hall IC is normal.
6. The mould stops for 1 second at maximum tilted conditions.
7. The mould returns to horizontal conditions as ice ejection motor rotates in reverse direction.
8. When the mould becomes horizontal, the cycle starts to repeat:  
Water Supply → Ice Making → Ice Ejection → Mould Returns to Horizontal

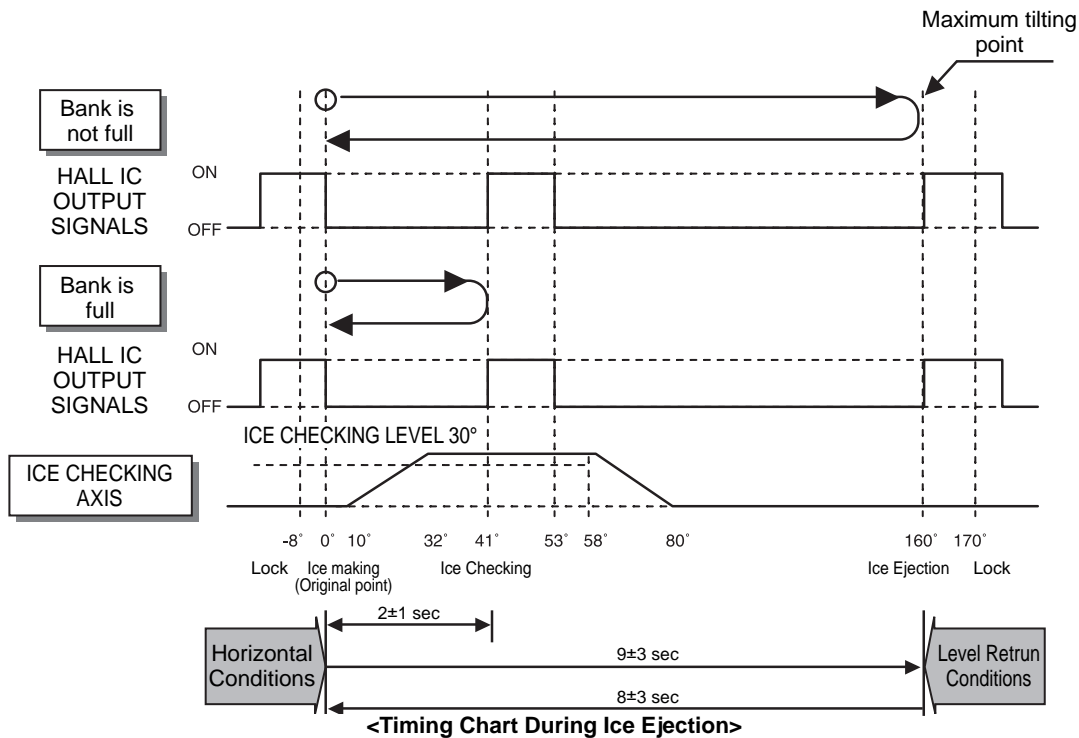

# ICE MAKER AND DISPENSER WORKING PRINCIPLES AND REPAIR

---

## 2-5 Test Function

1. It is to force the operation during operation test, service, and cleaning. The test switch is mounted under the automatic ice maker. The test function starts when the test switch is pressed for more than 0.5 second.
2. Test button does not work during ice ejection and water supply. It works when it is in the horizontal conditions. If mould is full of ice during test function operation, ice ejection control and water supply control do not work.
3. When test switch is pressed for more than 0.5 second in the horizontal conditions, ice ejection starts irrespect of the mould conditions. Water shall be splashed if test switch is pressed before the water in the mould freezes. Water shall be supplied while the mould returns to the horizontal conditions after ice ejection. Therefore the problems of ice ejection, returning to the horizontal conditions, and water supply can be checked by test switch. When test function performs normally, buzzer sounds and water supply shall carry out. Check it for repair if buzzer does not sound.
4. When water supply is completed, the cycle operates normally as follows: Ice making → Ice ejection → Returning to horizontal conditions → Water supply
5. Remove ice from the ice maker cube mould and press test switch when ice maker cube mould is full of ice as ice ejection and water supply control do not work when cube mould is full of ice.

## 2-6. Other functions relating to freezer compartment door opening

1. When freezer door is open, ice dispenser stops in order to reduce noise and ice drop.
2. When freezer door is open during ice ejection and cube mould returning to horizontal condition, ice ejection and cube mould level return proceed.
3. When freezer door is open, geared motor and cube ice solenoid immediately stop and duct door solenoid stops after 5 seconds.
4. Water dispenser stops in order to protect water drop when freezer door is open.
5. Test function operates normally irrespect of refrigearator compartment door opening.

# ICE MAKER AND DISPENSER WORKING PRINCIPLES AND REPAIR

## 3. Ice Maker Troubleshooting

\* **Troubleshooting:** it is possible to confirm by pressing freezer and refrigerator temperature control buttons for more than 1 second. (ice maker is normal if all leds are on): refer to trouble diagnosis function in MICOM function 2-8 (page 18)

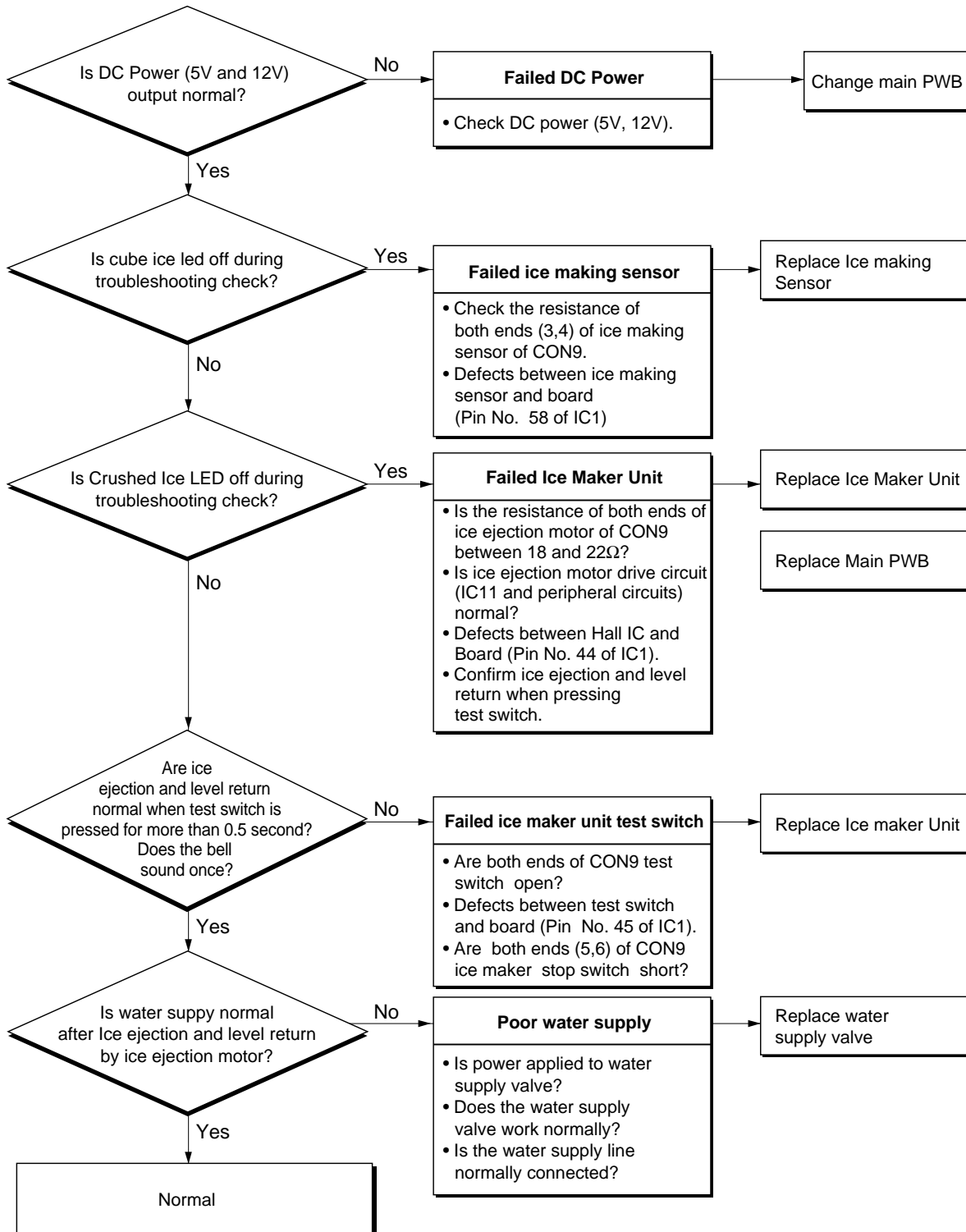



# ICE MAKER AND DISPENSER WORKING PRINCIPLES AND REPAIR

## 4. Ice Maker Circuits

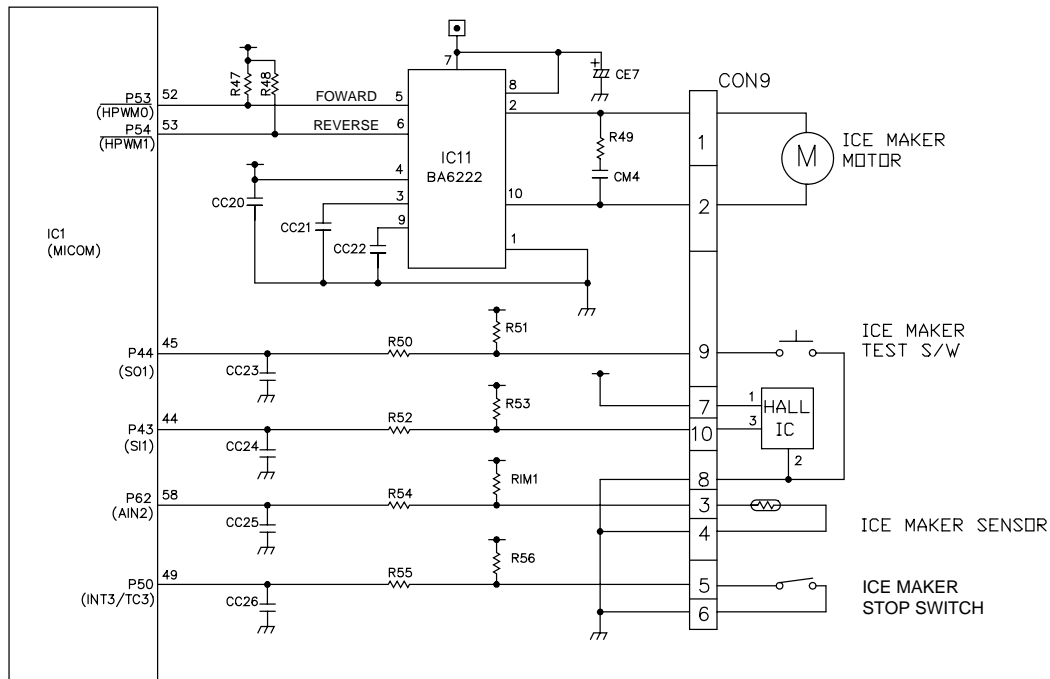

The above ice maker circuits are applied to GR-P247, GR-P207 and GR-L247, GR-L207 and composed of ice maker unit in the freezer and ice maker driving part of main PWB. Water is supplied to the ice maker cube mould through the solenoid relay for ice valve of solenoid valve in the machine room by opening valve for the set time. Water supply automatically stops when water supply time is elapsed. This circuit is to realize the functions such as ice ejection of ice maker cube mould, ice full detection, leveling, ice making temperature detection, etc. Refer to the temperature detecting circuits of Main PWB for ice making temperature detection. Ice maker test switch input detection is the same as the door switch input detection circuit of main PWB.

1. It is to force to operate during operation test, service, and cleaning. The test switch is mounted under the automatic ice maker. The test function starts when the test switch is pressed for more than 0.5 second.
2. Test button does not work during ice ejection and water supply. It works when it is in the horizontal conditions. If cube mould is full of ice during test function operation, ice ejection control and water supply control do not work.
3. Ice ejection carries out irrespect of ice formation in the ice making tray if test switch is pressed for more than 0.5 second. Water shall be splashed if test switch is pressed before the water in the mould is completely frozen. Water shall be supplied while the mould returns to the horizontal conditions after ice ejection. Therefore the problems of ice ejection, leveling, and water supply can be checked by test switch. When test function performs normally, buzzer sounds and water supply shall carry out. Check it for repair if buzzer does not sound.
4. When water supply is completed, normal cycle works: Ice Making → Ice Ejection → Level Return → Water Supply.
5. If ice maker stop switch is set to ON, normal cycle operates: Ice Making → Ice Ejection → Level Return → Water Supply. If it is set to OFF, ice making conducts but ice ejection, level return, and water supply do not work.

# CIRCUIT

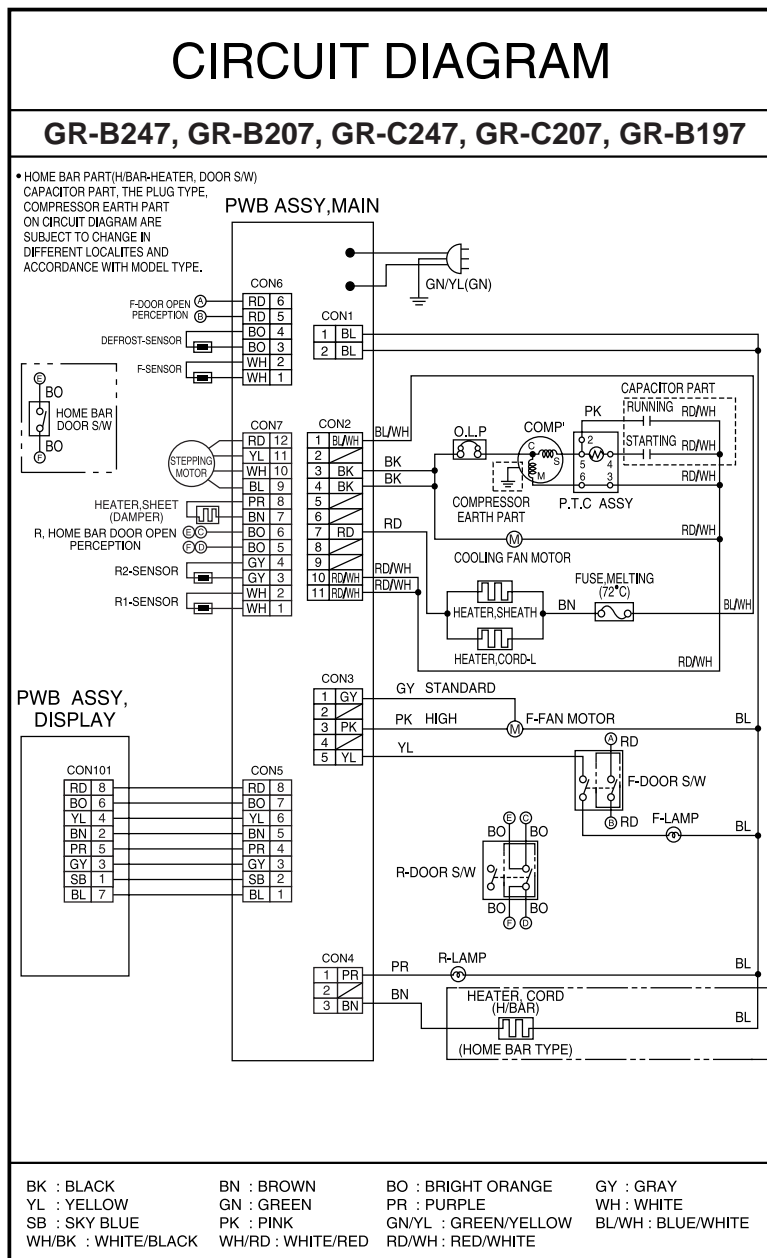

# CIRCUIT

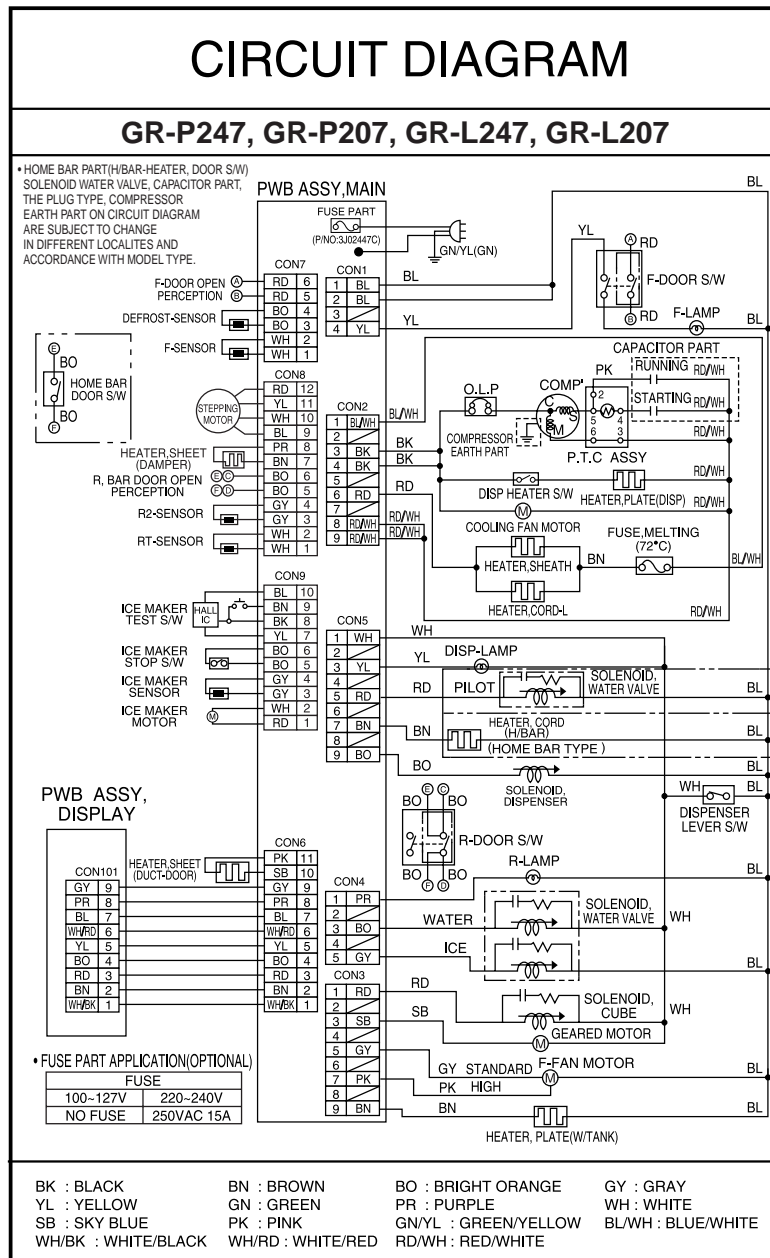

# TROUBLE DIAGNOSIS

## 1. TROUBLE SHOOTING

CLAIMS.	CAUSES AND CHECK POINTS.	HOW TO CHECK
<p>1. Faulty start</p>	<p>1) No power on outlet.            2) No power on cord.</p> <ul style="list-style-type: none"> <li>└ Bad connection between adapter and outlet. (faulty adapter)               <ul style="list-style-type: none"> <li>└ The Inner diameter of adapter.</li> <li>└ The distance between holes.</li> <li>└ The distance between terminals.</li> <li>└ The thickness of terminal.</li> </ul> </li> <li>└ Bad connection between plug and adapter (faulty plug).               <ul style="list-style-type: none"> <li>└ The distance between pins.</li> <li>└ Pin outer diameter.</li> </ul> </li> </ul> <p>3) Shorted start circuit.</p> <ul style="list-style-type: none"> <li>└ No power on power cord.               <ul style="list-style-type: none"> <li>└ Disconnected copper wire.                   <ul style="list-style-type: none"> <li>└ Power cord is disconnected.</li> <li>└ Faulty soldering.</li> </ul> </li> <li>└ Internal electrical short.</li> <li>└ Faulty terminal contact.                   <ul style="list-style-type: none"> <li>└ Loose contact.</li> <li>└ - Large distance between male terminal.</li> <li>└ - Thin female terminal.</li> <li>└ Terminal disconnected.</li> <li>└ Bad sleeve assembly.</li> </ul> </li> <li>└ Disconnected.                   <ul style="list-style-type: none"> <li>└ Weak connection.</li> <li>└ Short inserted cord length.</li> <li>└ Worn out tool blade.</li> </ul> </li> </ul> </li> <li>└ O.L.P is off.               <ul style="list-style-type: none"> <li>└ Capacity of O.L.P is small.</li> <li>└ Characteristics of O.L.P is bad.</li> <li>└ Bad connection.</li> <li>└ Power is disconnected.                   <ul style="list-style-type: none"> <li>└ Inner Ni-Cr wire blows out.</li> <li>└ Bad internal connection.</li> <li>└ Faulty terminal caulking (Cu wire is cut).</li> <li>└ Bad soldering.</li> </ul> </li> </ul> </li> <li>└ No electric power on compressor. - Faulty compressor.</li> <li>└ Faulty PTC.               <ul style="list-style-type: none"> <li>└ Power does not conduct. - Damage.</li> <li>└ Bad characteristics. - Initial resistance is big.</li> <li>└ Bad connection with compressor.                   <ul style="list-style-type: none"> <li>└ Too loose.</li> <li>└ Assembly is not possible.</li> </ul> </li> <li>└ Bad terminal connection.</li> </ul> </li> </ul> <p>4) During defrost.</p> <ul style="list-style-type: none"> <li>└ Start automatic defrost.</li> <li>└ Cycle was set at defrost when the refrigerator was produced.</li> </ul>	<p>* Measuring instrument :            Multi tester</p> <ul style="list-style-type: none"> <li>■ Check the voltage.              If the voltage is within <math>\pm 85\%</math> of the rated voltage, it is OK.</li> <li>■ Check the terminal movement.</li> <li>■ Check both terminals of power cord.              Power conducts : OK.              No power conducts : NG</li> <li>■ Check both terminals of O.L.P.              If power conducts : OK.              If not : NG.</li> <li>■ Check the resistance of both terminals.              At normal temperature <math>\theta</math> : OK.              If disconnected : <math>\infty</math>.</li> </ul>

# TROUBLE DIAGNOSIS

CLAIMS.	CAUSES AND CHECK POINTS.	HOW TO CHECK
<p>2. No cooling.</p>	<p>2) Refrigeration system is clogged.</p> <ul style="list-style-type: none"> <li>Moisture clogged.           <ul style="list-style-type: none"> <li>Residual moisture in the evaporator.               <ul style="list-style-type: none"> <li>Air Blowing.                   <ul style="list-style-type: none"> <li>Not performed.</li> <li>Too short.</li> <li>Impossible moisture confirmation.</li> <li>Low air pressure.</li> </ul> </li> <li>Leave it in the air.                   <ul style="list-style-type: none"> <li>During rest time.</li> <li>After work.</li> </ul> </li> <li>Caps are missed.</li> </ul> </li> <li>Residual moisture.               <ul style="list-style-type: none"> <li>Not dried in the compressor.</li> <li>Elapsed more than 6 months after drying</li> <li>Caps are missed.</li> <li>No pressure when it is open.</li> </ul> </li> </ul> </li> <li>No electric power on thermostat.           <ul style="list-style-type: none"> <li>Insufficient drier capacity.               <ul style="list-style-type: none"> <li>Dry drier - Drier temperature.</li> <li>Leave it in the air.                   <ul style="list-style-type: none"> <li>Check on package condition.</li> <li>Good storage after finishing.</li> </ul> </li> </ul> </li> <li>Residual moisture in pipes.               <ul style="list-style-type: none"> <li>Caps are missed.                   <ul style="list-style-type: none"> <li>During transportation.</li> <li>During work.</li> </ul> </li> <li>Air blowing.                   <ul style="list-style-type: none"> <li>Not performed.</li> <li>Performed.                       <ul style="list-style-type: none"> <li>Too short time.</li> <li>Low air pressure.</li> <li>Less dry air.</li> </ul> </li> </ul> </li> </ul> </li> <li>Moisture penetration - Leave it in the air. - Moisture penetration into the refrigeration oil.</li> </ul> </li> <li>Weld joint clogged.           <ul style="list-style-type: none"> <li>Short pipe insert.</li> <li>Pipe gaps.               <ul style="list-style-type: none"> <li>Too large.</li> <li>Damaged pipes.</li> </ul> </li> <li>Too much solder.</li> </ul> </li> <li>Drier doggeing.           <ul style="list-style-type: none"> <li>The capillary tube inserted depth. - Too much.</li> <li>Capillary tube melts. - Over heat.</li> <li>Clogged with foreign materials.               <ul style="list-style-type: none"> <li>Desiccant powder.</li> <li>Weld oxides.</li> <li>Drier angle.</li> </ul> </li> <li>Reduced cross section by cutting. - Squeezed.</li> </ul> </li> <li>Foreign material clogging.           <ul style="list-style-type: none"> <li>Compressor cap is disconnected.</li> <li>Foreign materials are in the pipe.</li> </ul> </li> </ul>	<ul style="list-style-type: none"> <li>■ Check the clogged evaporator by heating (as soon as the cracking sound begins, the evaporator start freezing)</li> <li>■ The evaporator does not cool from the beginnig (no evidede of misture attached). The evaporator is the same as before even heat is applied.</li> </ul>

# TROUBLE DIAGNOSIS

CLAIMS.	CAUSES AND CHECK POINTS.	HOW TO CHECK
<p>3. Refrigeration is weak.</p>	<p>1) Refrigerant Partly leaked. <span style="margin-left: 20px;">┌ Weld joint leak.</span>  <span style="margin-left: 40px;">└ Parts leak.</span></p> <p>2) Poor defrosting capacity.</p> <p style="margin-left: 20px;">┌ Drain path (pipe) clogged. <span style="margin-left: 20px;">┌ Inject P/U into drain hose. <span style="margin-left: 20px;">┌ Inject through the hole.</span>  <span style="margin-left: 40px;">└ Seal with drain.</span></span></p> <p style="margin-left: 60px;">└ Foreign materials penetration. <span style="margin-left: 20px;">┌ P/U lump input.</span>  <span style="margin-left: 40px;">└ Screw input.</span>  <span style="margin-left: 60px;">└ Other foreign materials input.</span></p> <p style="margin-left: 40px;">└ Cap drain is not disconnected.</p> <p style="margin-left: 20px;">└ Defrost heater does not generate heat. <span style="margin-left: 20px;">┌ Parts disconnected. <span style="margin-left: 20px;">┌ Plate heater <span style="margin-left: 20px;">┌ Wire is cut.</span>  <span style="margin-left: 40px;">└ Heating wire.</span>  <span style="margin-left: 60px;">└ Contact point between heating and electric wire.</span>  <span style="margin-left: 40px;">└ Dent by fin evaporator.</span>  <span style="margin-left: 60px;">└ Poor terminal contacts.</span></span></span></p> <p style="margin-left: 60px;">└ Cord heater <span style="margin-left: 20px;">┌ Wire is cut.</span>  <span style="margin-left: 40px;">└ Lead wire.</span>  <span style="margin-left: 60px;">└ Heating wire.</span>  <span style="margin-left: 80px;">└ Contact point between heating and electric wire.</span>  <span style="margin-left: 60px;">└ Heating wire is corroded</span>  <span style="margin-left: 80px;">└ Water penetration.</span>  <span style="margin-left: 60px;">└ Bad terminal connection.</span></p>	<p>■ Check visually.</p> <p>■ Check terminal Conduction: OK.          No conduction: NG.          If wire is not cut, refer to resistance.          P=Power          V=Voltage          R=Resistance</p> $P = \frac{V^2}{R}$ $R = \frac{V^2}{P}$

# TROUBLE DIAGNOSIS

CLAIMS.	CAUSES AND CHECK POINTS.	HOW TO CHECK
<p>3. Refrigeration is weak.</p>	<ul style="list-style-type: none"> <li>- Residual frost.               <ul style="list-style-type: none"> <li>- Weak heat from heater.                   <ul style="list-style-type: none"> <li>- Sheath Heater - rated.</li> <li>- Heater plate - rated.</li> <li>- Heater cord-L - rated.</li> </ul> </li> <li>- Bad heater assembly.                   <ul style="list-style-type: none"> <li>- Heater plate                       <ul style="list-style-type: none"> <li>- No contact to drain.</li> <li>- Loosened stopper cord.</li> </ul> </li> <li>- Heater cord-L                       <ul style="list-style-type: none"> <li>- Not contact to the evaporator pipe.</li> <li>- Location of assembly (top and middle).</li> </ul> </li> </ul> </li> <li>- Too short defrosting time.                   <ul style="list-style-type: none"> <li>- Defrost Sensor.</li> <li>- Faulty characteristics.</li> <li>- Seat-D(missing, location, thickness).</li> </ul> </li> <li>- Structural fault.                   <ul style="list-style-type: none"> <li>- Gasket gap.</li> <li>- Air inflow through the fan motor.</li> <li>- Bad insulation of case door.</li> </ul> </li> </ul> </li> <li>- No automatic defrosting.</li> <li>- Defrost does not return.</li> </ul> <p>3) Cooling air leak.</p> <ul style="list-style-type: none"> <li>- Bad gasket adhesion               <ul style="list-style-type: none"> <li>- Gap.</li> <li>- Bad attachment.</li> <li>- Contraction.</li> </ul> </li> <li>- Door sag.               <ul style="list-style-type: none"> <li>- Bad adhesion.</li> <li>- Weak binding force at hinge.</li> </ul> </li> </ul> <p>4) No cooling air circulation.</p> <ul style="list-style-type: none"> <li>- Faulty fan motor.               <ul style="list-style-type: none"> <li>- Fan motor.                   <ul style="list-style-type: none"> <li>- Self locked.</li> <li>- Wire is cut.</li> <li>- Bad terminal contact.</li> </ul> </li> <li>- Door switch.                   <ul style="list-style-type: none"> <li>- Faults.                       <ul style="list-style-type: none"> <li>- Contact distance.</li> <li>- Button pressure.</li> <li>- Melted contact.</li> <li>- Contact.</li> </ul> </li> <li>- Refrigerator and freezer switch reversed.</li> <li>- Button is not pressed.                       <ul style="list-style-type: none"> <li>- Poor door attachment.</li> <li>- Door liner (dimension).</li> <li>- Contraction inner liner.</li> <li>- Misalignment.</li> <li>- Bad terminal connection.</li> <li>- P/U liquid leak.</li> </ul> </li> </ul> </li> </ul> </li> </ul>	<p>■ Check the fan motor conduction: OK. No conduction: NG.</p>

# TROUBLE DIAGNOSIS

CLAIMS.	CAUSES AND CHECK POINTS.	HOW TO CHECK
<p>3. Refrigeration is weak.</p>	<p>4) No cooling air circulation.</p> <ul style="list-style-type: none"> <li>Faulty fan motor. — Fan is constrained.               <ul style="list-style-type: none"> <li>Fan shroud contact. - Clearance.</li> <li>Damping evaporator contact.</li> <li>Accumulated residual frost.</li> </ul> </li> <li>Small cooling air discharge.               <ul style="list-style-type: none"> <li>Insufficient motor RPM                   <ul style="list-style-type: none"> <li>Fan overload. - Fan misuse.</li> <li>Bad low temperature RPM characteristics.</li> <li>Rated power misuse.</li> <li>Low voltage.</li> </ul> </li> <li>Faulty fan.                   <ul style="list-style-type: none"> <li>Fan misuse.</li> <li>Bad shape.</li> <li>Loose connection. - Not tightly connected.</li> <li>Insert depth.</li> </ul> </li> <li>Shroud. — Bent.</li> <li>Ice and foreign materials on rotating parts.</li> </ul> </li> </ul> <p>5) Compressor capacity.           <ul style="list-style-type: none"> <li>Rating misuse.</li> <li>Small capacity.</li> <li>Low voltage.</li> </ul> </p> <p>6) Refrigerant too much or too little.           <ul style="list-style-type: none"> <li>Malfunction of charging cylinder.</li> <li>Wrong setting of refrigerant.</li> <li>Insufficient compressor. - Faulty compressor.</li> </ul> </p> <p>7) Continuous operation           <ul style="list-style-type: none"> <li>- No contact of temperature controller. - Foreign materials.</li> </ul> </p> <p>8) Damper opens continuously.           <ul style="list-style-type: none"> <li>Foreign materials jammed.               <ul style="list-style-type: none"> <li>P/U liquid dump.</li> <li>EPS water sediment.</li> <li>Screw.</li> </ul> </li> <li>Failed sensor. - Position of sensor.</li> <li>Characteristics of damper.               <ul style="list-style-type: none"> <li>Bad characteristics of its own temperature.</li> <li>Parts misuse.</li> <li>Change of temperature - Impact characteristics.</li> </ul> </li> </ul> </p> <p>9) Food storing place. - Near the outlet of cooling air.</p>	<p>■ Check visually after disassembly.</p> <p>■ Check visually after disassembly.</p>



# TROUBLE DIAGNOSIS

CLAIMS.	CAUSES AND CHECK POINTS.	HOW TO CHECK
<p>4. Warm refrigerator compartment temperature.</p>	<p>1) Colgged cooling path.</p> <ul style="list-style-type: none"> <li>└ P/U liquid leak.</li> <li>└ Foreign materials. — P/U dump liquid.</li> </ul> <p>2) Food storate.</p> <ul style="list-style-type: none"> <li>└ Store hot food.</li> <li>└ Store too much at once.</li> <li>└ Door open.</li> <li>└ Packages block air flow.</li> </ul>	
<p>5. No automatic operation. (faulty contacts.)</p>	<p>1) Faulty temperature sensor in freezer or refrigerator compartment.</p> <ul style="list-style-type: none"> <li>└ Faulty contact.</li> <li>└ Faulty temperature characteristics.</li> </ul> <p>2) Refrigeration load is too much.</p> <ul style="list-style-type: none"> <li>└ Food. <ul style="list-style-type: none"> <li>└ Too much food.</li> <li>└ Hot food.</li> </ul> </li> <li>└ Frequent opening and closing.</li> <li>└ Cool air leak.</li> <li>└ Poor door close. — Partly opens.</li> </ul> <p>3) Poor insulation.</p> <p>4) Bad radiation.</p> <ul style="list-style-type: none"> <li>└ High ambient temperature.</li> <li>└ Space is secluded.</li> </ul> <p>5) Refrigerant leak.</p> <p>6) Inadequate of refrigerant.</p> <p>7) Weak compressor discharging power.</p> <ul style="list-style-type: none"> <li>└ Different rating.</li> <li>└ Small capacity.</li> </ul> <p>8) Fan does not work.</p> <p>9) Button is positioned at "strong."</p>	<p>■ Inspect parts measurements and check visually.</p>
<p>6. Dew and ice formation.</p>	<p>1) Ice in freezer compartment.</p> <ul style="list-style-type: none"> <li>└ External air inflow. — Rubber motor assembly direction(reverse).</li> <li>└ Door opens but not closes. <ul style="list-style-type: none"> <li>└ Weak door closing power.</li> <li>└ Stopper malfunction.</li> <li>└ Door sag.</li> <li>└ Food hinders door closing.</li> </ul> </li> <li>└ Gap around gasket. — Contraction, distortion, loose, door twisted, corner not fully inserted.</li> <li>└ Food vapor. — Storing hot food. — Unsealed food.</li> </ul> <p>2) Condensation in the refrigerator compartment.</p> <ul style="list-style-type: none"> <li>└ Door opens but not closes. <ul style="list-style-type: none"> <li>└ Insufficient closing.</li> <li>└ Door sag.</li> <li>└ Food hinders door closing.</li> </ul> </li> <li>└ Gasket gap.</li> </ul> <p>3) Condensation on liner foam.</p> <ul style="list-style-type: none"> <li>└ Cool air leak and transmitted. <ul style="list-style-type: none"> <li>└ Not fully filled. <ul style="list-style-type: none"> <li>└ Toop table part.</li> <li>└ Out plate R/L part.</li> </ul> </li> <li>└ Flange gap. — Not sealed.</li> <li>└ Gasket gap.</li> </ul> </li> </ul>	

# TROUBLE DIAGNOSIS

CLAIMS.	CAUSES AND CHECK POINTS.	HOW TO CHECK
<p>6. Dew and ice formation.</p>	<p>4) Dew on door.</p> <ul style="list-style-type: none"> <li>— Dew on the duct door. - Duct door heater is cut.</li> <li>— Dew on the dispense recess.               <ul style="list-style-type: none"> <li>— Recess Heater is cut.</li> <li>— Duct door is open. / Foreign material clogging.</li> </ul> </li> <li>— Dew on the door surface.               <ul style="list-style-type: none"> <li>— Not fully filled.                   <ul style="list-style-type: none"> <li>— Surface. Liquid shortage.</li> <li>— Corner. Liquid leak.</li> </ul> </li> <li>— P/U liquid contraction.</li> </ul> </li> <li>— Dew on the gasket surface.               <ul style="list-style-type: none"> <li>— Bad wing adhesion.                   <ul style="list-style-type: none"> <li>— Wing sag(lower part).</li> <li>— Door liner shape mismatch.</li> </ul> </li> <li>— Corner.                   <ul style="list-style-type: none"> <li>— Too much notch.</li> <li>— Broken.</li> </ul> </li> <li>— Home Bar heater is cut.</li> </ul> </li> </ul> <p>5) Water on the floor.</p> <ul style="list-style-type: none"> <li>— Dew in the refrigerator compartment.</li> <li>— Defrosted water overflows. — Clogged discharging hose.</li> <li>— Discharging hose location. — Evaporation tray located at wrong place.</li> <li>— Tray drip.               <ul style="list-style-type: none"> <li>— Damaged.</li> <li>— Breaks, holes.</li> <li>— Small Capacity.</li> </ul> </li> <li>— Position of drain.</li> </ul>	
<p>7. Sounds</p>	<p>1) Compressor compartment operating sounds.</p> <ul style="list-style-type: none"> <li>— Compressor sound inserted.               <ul style="list-style-type: none"> <li>— Sound from machine itself.</li> <li>— Sound from vibration.                   <ul style="list-style-type: none"> <li>— Restrainer.</li> <li>— Rubber seat.                       <ul style="list-style-type: none"> <li>— Too hard.</li> <li>— Distorted.</li> <li>— Aged.</li> <li>— Burnt.</li> </ul> </li> <li>— Stopper.— Bad Stopper assembly.                       <ul style="list-style-type: none"> <li>— Not fit (inner diameter of stopper).</li> <li>— Tilted.</li> <li>— Not</li> </ul> </li> </ul> </li> <li>— Compressor base not connected.</li> <li>— Bad welding compressor stand(fallen).</li> <li>— Foreign materials in the compressor compartment.</li> </ul> </li> <li>— O.L.P. sound. — Chattering sound.</li> <li>— Capacitor noise. — Insulation paper vibration.</li> <li>— Pipe sound.               <ul style="list-style-type: none"> <li>— Pipe contacts each other. – Narrow interval.</li> <li>— No vibration damper.                   <ul style="list-style-type: none"> <li>— Damping rubber-Q.</li> <li>— Damping rubber-S.</li> </ul> </li> <li>— Capillary tube unattached.</li> </ul> </li> </ul>	

# TROUBLE DIAGNOSIS

CLAIMS.	CAUSES AND CHECK POINTS.	HOW TO CHECK
7. Sounds	<p>1) Compressor compartment operating sounds.</p> <ul style="list-style-type: none"> <li>Transformer sound.               <ul style="list-style-type: none"> <li>Its own fault. — Core gap.</li> <li>Bad connection. — Correct screw connection.</li> </ul> </li> <li>Drip tray vibration sound.               <ul style="list-style-type: none"> <li>Bad assembly.</li> <li>Distortion.</li> <li>Foreign materials inside.</li> </ul> </li> <li>Back cover machine sound.               <ul style="list-style-type: none"> <li>Bad connection.</li> <li>Partly damaged.</li> </ul> </li> <li>Condenser drain sound.               <ul style="list-style-type: none"> <li>Not connected.</li> <li>Bad pipe caulking.</li> </ul> </li> </ul> <p>2) Freezer compartment sounds.</p> <ul style="list-style-type: none"> <li>Fan motor sound.               <ul style="list-style-type: none"> <li>Normal operating sound.</li> <li>Vibration sound.                   <ul style="list-style-type: none"> <li>Aged rubber seat.</li> <li>Bad torque for assembling motor bracket.</li> </ul> </li> </ul> </li> <li>Sounds from fan contact.               <ul style="list-style-type: none"> <li>Fan guide contact.</li> <li>Shroud burr contact.</li> <li>Damping evaporator contact.</li> <li>Residual frost contact.                   <ul style="list-style-type: none"> <li>Poor treatment Cord heater.</li> <li>Narrow evaporator interval.</li> </ul> </li> </ul> </li> <li>Unbalance fan sounds.               <ul style="list-style-type: none"> <li>Unbalance.                   <ul style="list-style-type: none"> <li>Surface machining conditions.</li> <li>Fan distortion.</li> <li>Misshappen.</li> <li>Burr.</li> </ul> </li> <li>Ice on the fan. — Air intake (opposite to motor rubber assembly)</li> </ul> </li> <li>Motor shaft contact sounds.               <ul style="list-style-type: none"> <li>Supporter disorted.</li> <li>Tilted during motor assembly.</li> </ul> </li> <li>Resonance.</li> <li>Evaporator noise.               <ul style="list-style-type: none"> <li>Evaporator pipe contact. — No damping evaporator.</li> <li>Sound from refrigerant. — Stainless steel pipe shape in accumulator.</li> <li>Sound from fin evaporator and pipe during expansion and contraction.</li> </ul> </li> </ul> <p>3) Bowls and bottles make contact on top shelf.</p> <p>4) Refrigerator roof contact.</p> <p>5) Refrigerator side contact.</p> <p>6) Insufficient Lubricants on door hinge.</p>	

# TROUBLE DIAGNOSIS

CLAIMS.	CAUSES AND CHECK POINTS.	HOW TO CHECK
<p>8. Faulty lamp (freezer and refrigerator compartment).</p>	<p>1) Lamp problem. — Filament blows out. — Glass is broken.</p> <p>2) Bad lamp assembly. — Not inserted. — Loosened by vibration.</p> <p>3) Bad lamp socket.</p> <ul style="list-style-type: none"> <li>— Disconnection. — Bad soldering. — Bad rivet contact.</li> <li>— Short. — Water penetration. — Low water level in tray.</li> <li>— Bad elasticity of contact.</li> <li>— Bad contact (corrosion).</li> </ul> <p>4) Door switch. — Its own defect. — Refrigerator and freezer switch is reversed. — Travel distance. — Bad connection. — Bad terminal contact. — P/U liquid leak..</p>	
<p>9. Faulty internal voltage (short).</p>	<p>1) Lead wire is damaged.</p> <ul style="list-style-type: none"> <li>— Wire damage when assembling P.T.C. Cover.</li> <li>— Outlet burr in the bottom plate.</li> <li>— Pressed by cord heater. lead wire, evaporator pipe.</li> </ul> <p>2) Exposed terminal.</p> <ul style="list-style-type: none"> <li>— Compressor Compartment terminal. - Touching other components.</li> <li>— Freezer compartment terminal. - Touching evaporator pipe.</li> </ul> <p>3) Faulty parts.</p> <ul style="list-style-type: none"> <li>— Transformer. — Coil contacts cover. — Welded terminal parts contact cover.</li> <li>— Compressor. — Bad coil insulation.</li> <li>— Plate heater.</li> <li>— Melting fuse. — Sealing is broken. — Moisture penetration.</li> <li>— Cord heater. — Pipe damaged. — Moisture penetration. — Bad sealing.</li> <li>— Sheath heater.</li> </ul>	<p>■ Connect conduction and non-conduction parts and check with tester. Conduction: NG. Resistance: OK.</p>

# TROUBLE DIAGNOSIS

CLAIMS.	CAUSES AND CHECK POINTS.	HOW TO CHECK
<p>10. Structure, appearance and others.</p>	<p>1) Door foam.</p> <ul style="list-style-type: none"> <li>Sag.           <ul style="list-style-type: none"> <li>Weak torque of hinge connection.               <ul style="list-style-type: none"> <li>Bolt is loosened during transportaion.</li> <li>Not tightly fastened.</li> <li>Screw worn out .</li> </ul> </li> <li>Weak gasket adhesion.               <ul style="list-style-type: none"> <li>Adhesion surface.</li> </ul> </li> <li>Fixed tape.               <ul style="list-style-type: none"> <li>Not well fixed.</li> </ul> </li> </ul> </li> <li>Noise during operation.           <ul style="list-style-type: none"> <li>Hinge interference.               <ul style="list-style-type: none"> <li>Bigger door foam.</li> <li>Hinge-Pin tilted-Poor flatness.</li> <li>No washer.</li> <li>No grease and not enough quantity.</li> </ul> </li> </ul> </li> <li>Malfunction.           <ul style="list-style-type: none"> <li>Not closed Interference between door liner and inner liner.</li> <li>Refrigerator compartment is opened when freezer compartment is closed (faulty stopper).               <ul style="list-style-type: none"> <li>Stopper worn out.</li> <li>Bad freezer compartment door assembly.</li> <li>No stopper.</li> </ul> </li> </ul> </li> </ul> <p>2) Odor.</p> <ul style="list-style-type: none"> <li>Temperature of refrigerator compartment.           <ul style="list-style-type: none"> <li>High.               <ul style="list-style-type: none"> <li>Faulty damper control.</li> <li>Button is set at "weak".</li> <li>Door is open (interference by food).</li> </ul> </li> </ul> </li> <li>Deodorizer.           <ul style="list-style-type: none"> <li>No deodorizer.</li> <li>Poor capacity.</li> </ul> </li> <li>Food Storage.           <ul style="list-style-type: none"> <li>Seal condition.</li> <li>Store special odorous food.</li> <li>Long term storage.</li> </ul> </li> <li>Others.           <ul style="list-style-type: none"> <li>Odors from chemical procutcs.</li> </ul> </li> </ul>	

# TROUBLE DIAGNOSIS

## 2. Faults

### 2-1- Power

Problems	Causes	Checks	Measures	Remarks
No power on outlet.	<ul style="list-style-type: none"> <li>- Power cord cut.</li> <li>- Faulty connector insertion.</li> <li>- Faulty connection between plug and adapter.</li> </ul>	<ul style="list-style-type: none"> <li>- Check the voltage with tester.</li> <li>- Check visually.</li> <li>- Check visually.</li> </ul>	<ul style="list-style-type: none"> <li>- Replace the components.</li> <li>- Reconnect the connecting parts.</li> <li>- Reconnect the connecting parts.</li> </ul>	
Fuse blows out.	<ul style="list-style-type: none"> <li>- Short circuit by wrong connection.</li> <li>- Low voltage products are connected to high voltage.</li> <li>- Short circuit by insects.</li> <li>- Electricity leakage.</li> <li>- High voltage.</li> <li>- Short circuit of components (tracking due to moisture and dust penetration).</li> </ul>	<ul style="list-style-type: none"> <li>- Check the fuse with tester or visually.</li> <li>- Check the input volt are with tester (between power cord and products).</li> <li>- Check the resistance of power cord with tester (if it is 0Ω, it is shorted).</li> </ul>	<ul style="list-style-type: none"> <li>- Find and remove the cause of problem(ex. short, high voltage, low voltage).</li> <li>- Replace with rated fuse.</li> </ul>	<ul style="list-style-type: none"> <li>- Replace with rated fuse after confirming its specification.</li> <li>■ If fuse blows out frequently, reconfirm the cause and prevent.</li> </ul>

### 2-2. Compressor

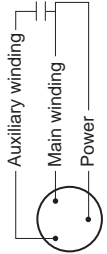
Problems	Causes	Checks	Measures	Remarks
Compressor does not operate.	<ul style="list-style-type: none"> <li>- Faulty PTC.</li> <li>- Compressor is frozen.</li> </ul>	<ul style="list-style-type: none"> <li>- Check the resistance. Value:∞ is defective.</li> </ul>	<ul style="list-style-type: none"> <li>- If resistance is infinite, replace it with new one.</li> <li>- If it is not infinite, it is normal.</li> <li>- Check other parts.</li> </ul>	
		<ul style="list-style-type: none"> <li>- If compressor assembly parts are normal(capacitor, PTC, OLP), apply power directly to the compressor to force operation.</li> </ul>  <p>OLP It starts as soon as it is contacted.</p>	<ul style="list-style-type: none"> <li>- During forced operation:</li> <li>- Operates: Check other parts.</li> <li>- Not operate: Replace the frozen compressor with new one, weld, evacuate, and recharge refrigerant.</li> </ul>	<ul style="list-style-type: none"> <li>• Refer to weld repair procedures.</li> </ul>

### 2-3. Temperature

Problems	Causes	Checks	Measures	Remarks
High temperature in the freezer compartment.	Poor cool air circulation due to faulty fan motor.	<ul style="list-style-type: none"> <li>- Lock — Check resistance with a tester. 0Ω: short. ∞Ω: cut.</li> <li>- Rotate rotor manually and check rotation.</li> <li>- Wire is cut.</li> <li>- Bad terminal contact: Check terminal visually.</li> <li>- Fan constraint. – Fan shroud contact: Confirm visually.</li> <li>– Fan icing: Confirm visually.</li> </ul>	<ul style="list-style-type: none"> <li>- Replace fan motor.</li> <li>- Reconnect and reinsert.</li> <li>- Maintain clearance and remove ice (Repair and/or replace shroud if fan is constrained by shroud deformation).</li> </ul>	
	Faulty fan motor due to faulty door switch operation.	<ul style="list-style-type: none"> <li>- Iced button (faulty) operation: Press button to check</li> <li>- Faulty button pressure and contact: Press button to check operation.</li> <li>- Door cannot press door switch button: Check visually.</li> </ul>	<ul style="list-style-type: none"> <li>- Confirm icing causes and repair.</li> <li>- Replace door switch.</li> <li>- Door sag: fix door.</li> <li>- Door liner bent: replace door or attach sheets.</li> </ul>	
	Bad radiation conditions in compressor compartment.	<ul style="list-style-type: none"> <li>- Check the clearance between the refrigerator and wall (50 mm in minimum).</li> <li>- Check dust on the grill in compressor compartment.</li> <li>- Check dust on the coils condenser.</li> </ul>	<ul style="list-style-type: none"> <li>- Keep clearance between refrigerator and walls (minimum 50mm).</li> <li>- Remove dust and contaminants from grill for easy heat radiation.</li> <li>- Remove the dust with vacuum cleaner from the coils condenser while the refrigerator is off.</li> </ul>	<ul style="list-style-type: none"> <li>- The fan may be broken if cleaning performs while the refrigerator is on.</li> </ul>

## 2-4. Cooling

Problems	Causes	Checks	Measures	Remarks
High temperature in the freezer compartment.	Refrigerant leak.	<p><u>Check sequence</u></p> <ol style="list-style-type: none"> <li>1. Check the welded parts of the drier inlet and outlet and drier auxiliary in the compressor compartment (high pressure side).</li> <li>2. Check the end of compressor sealing pipe (low pressure side).</li> <li>3. Check silver soldered parts. (Cu + Fe / Fe + Fe).</li> <li>4. Check bending area of wire condenser pipe in compressor compartment (cracks can happen during bending).</li> <li>5. Check other parts (compressor compartment and evaporators in freezer compartment).</li> </ol>	Weld the leaking part, recharge the refrigerant.	Drier must be replaced.
	Shortage of refrigerant.	<p>Check frost formation on the surface of evaporator in the freezer compartment.</p> <ul style="list-style-type: none"> <li>- If the frost forms evenly on the surface, it is OK.</li> <li>- If it does not, it is not good.</li> </ul>	<ul style="list-style-type: none"> <li>- Find out the leaking area, repair, evacuate, and recharge the refrigerant.</li> <li>- No leaking, remove the remaining refrigerant, and recharge new refrigerant.</li> </ul>	Drier must be replaced.



# TROUBLE DIAGNOSIS

Problems	Causes	Checks	Measures	Remarks
High temperature in the freezer compartment.	Cycle pipe is clogged.	<p>Check sequence.</p> <ol style="list-style-type: none"> <li>1. Check temperature of condenser manually. If it is warm, it is OK. If it is not, compressor discharging joints might be clogged.</li> <li>2. Manually check whether hot line pipe is warm. If it is warm, it's OK. If it is not, condenser outlet weld joints might be clogged.</li> </ol>	<ul style="list-style-type: none"> <li>- Heat up compressor discharging weld joints with touch, disconnect the pipes, and check the clogging. Remove the causes of clogging, weld, evacuate, and recharge the refrigerant.</li> <li>- If it's warm, it's OK. If it's not, condenser discharging line weld joints might be clogged. Disconnect with torch, remove the causes, evacuate, and recharge seal refrigerant.</li> </ul>	Drier must be replaced.
	Leak at loop pipe weld joint (discharge) in compressor.	<p>Check sequence.</p> <ol style="list-style-type: none"> <li>1. Manually check whether condenser is warm, it is not warm and the frost forms partly on the evaporator in the freezer compartment.</li> </ol>	<ul style="list-style-type: none"> <li>Replace the compressor, weld, evacuate, and recharge refrigerant.</li> </ul>	Drier must be replaced.
	Faulty cooling fan in the compressor compartment.	<p>Check sequence.</p> <ol style="list-style-type: none"> <li>1. Check cooling fan operation.</li> <li>2. Check that cooling fan is disconnected from the motor.</li> </ol>	<ul style="list-style-type: none"> <li>- Replace if motor does not operate.</li> <li>- If fan is disconnected, check fan damage and reassemble it.</li> <li>■ Refer to fan motor disassembly and assembly sequence.</li> </ul>	

## 2-5. Defrosting failure

Problems	Causes	Checks	Measures	Remarks
No defrosting.	<p>Heater does not generate heat as the heating wire is cut or the circuit is shorted.</p> <ol style="list-style-type: none"> <li>1) Heating wire is damaged when inserting into the evaporator.</li> <li>2) Lead wire of heater is cut.</li> <li>3) Heating wire at lead wire contacts is cut.</li> </ol>	<ol style="list-style-type: none"> <li>1. Check the resistance of heater. 0Ω: Short. ∞Ω: Cut. Tens to thousands Ω: OK.</li> <li>2. Check the resistance between housing terminal and heater surface. 0Ω: Short. ∞Ω: Cut. Tens to thousands Ω: Short.</li> </ol>	<p>Heating wire is short and wire is cut.</p> <ul style="list-style-type: none"> <li>• Parts replacement: Refer to parts explanations.</li> </ul>	<p>Seal the lead wire with insulation tape and heat contraction tube if the cut lead wire is accessible to repair.</p>
Sucking duct and discharging hole are clogged:	<ol style="list-style-type: none"> <li>1. Impurities.</li> <li>2. Ice.</li> </ol>	<ol style="list-style-type: none"> <li>1. Confirm foreign materials. In case of ice, insert the copper line through the hole to check.</li> <li>2. Put hot water into the drain (check drains outside).</li> </ol>	<ol style="list-style-type: none"> <li>1) Push out impurities by inserting copper wire. (Turn off more than 3 hours and pour in hot water if frost is severe.)</li> <li>2) Put in hot water to melt down frost.</li> <li>3) Check the water outlet.</li> <li>4) Push the heater plate to sucking duct manually and assemble the disconnected parts.</li> </ol>	
Gap between Sucking duct and Heater plate (ice in the gap).		<ol style="list-style-type: none"> <li>1. Confirm in the Sucking duct.</li> </ol>	<ol style="list-style-type: none"> <li>1) Turn off the power, confirm impurities and ice in the gap, and supply hot water until the ice in the gap melts down.</li> <li>2) Push the Heater plate to drain bottom with hand and assemble the disconnected parts.</li> </ol>	
Wrong heater rating (or wrong assembly).		<ol style="list-style-type: none"> <li>1. Check heater label.</li> <li>2. Confirm the capacity after substituting the resistance value into the formula.  <math display="block">P = \frac{V^2}{R}</math> <p>(V: Rated voltage of user country)  (R: Resistance of tester[Ω])</p> Compare P and level capacity.  Tolerance: ±7%</li> </ol>	<p>Faults: replace.  - How to replace: Refer to main parts.</p>	

# TROUBLE DIAGNOSIS

Problems	Causes	Checks	Measures	Remarks
No defrosting	<p>Melting fuse blows out.</p> <p>1) Lead wire is cut.</p> <p>2) Bad soldering.</p> <p>Ice in the Sucking duct.</p> <p>1) Icing by foreign materials in the duct.</p> <p>2) Icing by cool air inflow through the gap of heater plate.</p> <p>3) Icing by the gap of heater plate.</p>	<p>- Check melting fuse with tester. - If 0Ω: OK.</p> <p>If ∞Ω: wire is cut.</p> <p>1. Check the inner duct with mirror.</p> <p>2. Check by inserting soft copper wire into the duct (soft and thin copper not to impair heating wire).</p>	<p>Faulty parts: parts replacement.</p> <p>- Check wire color when measuring resistance with a tester.</p> <p>1) Turn power off.</p> <p>2) Raise the front side(door side), support the front side legs, and let the ice melt naturally. (If power is on, melt the frost by forced defrosting.)</p> <p>3) Reassemble the heater plate.</p>	
	<p>Bad cool air inflow and discharge, and bad defrosting due to faulty contact and insertion (bad connector insertion into housing of heater, melting, fuse and motor fan).</p>	<p>1. Turn on power, open or close the door, check that motor fan operates (If it operates, motor fan is OK).</p> <p>2. Disconnect parts in the refrigerator compartment, check the connection around the housing visually, defrost, and confirm heat generation on the heater. Do not put hands on the sheath heater.</p> <p>3. Check the parts which have faults described in 1, 2 (mechanical model: disconnect thermostat from the assembly).</p>	<p>1) Check the faulty connector of housing and reassemble wrongly assembled parts.</p> <p>2) If the parts are very damaged, remove the parts and replace it with a new one.</p>	

## 2-6. Icing

Problems	Causes	Checks	Measures	Remarks
Icing in the refrigerator compartment. - Damper icing. - Pipe icing. - Discharging pipe icing.	1) Bad circulation of cool air. - Clogged intake port in the refrigerator compartment. - Sealing is not good. - Too much food is stored and clogs the discharge port. - Bad defrosting.	- Check the food is stored properly (check discharge and intake port are clogged). - Check icing on the surface of baffle and cool air path (pipe) after disassembling the container box. - Check icing at intake ports of freezer and refrigerator compartment.	- Be acquainted with how to use. - Sealing on connecting parts. - Check the damper and replace it if it has defects. - Check defrost. (After forced defrosting, check ice in the evaporator and pipes.)	- Check the defrost related parts if problem is caused by faulty defrosting.
	2) Faulty door or refrigerator compartment. - Faulty gasket. - Faulty assembly.	- Check gasket attached conditions. - Check door assembly conditions.	- Correct the gasket attachment conditions and replace it. - Door assembly and replacement.	- Replacement should be done when it cannot be repaired.
	3) Overcooling in the refrigerator compartment. - Faulty damper in the refrigerator compartment. - Faulty MICOM (faulty sensor)	- Check refrigerator compartment is overcooled (when button pressed on "weak"). - Check parts are faulty.	- Replace faulty parts.	
	4) Bad defrosting - Heater wire is cut. - Defective defrost sensor. - Defrosting cycle.	- Check frost on the evaporator after disassembling shroud and fan grille. - Check ice on intake port of freezer and refrigerator compartment.	- Check parts related to defrosting. - Check defrosting. (Check ice on the evaporator and pipe.)	- Moisture cannot frost on the evaporator but can be sucked into the refrigerator, being condensed and iced, interferes with cool air circulation, and suppresses sublimation.
	5) Customers are not familiar with this machine. - Door opens. - High temperature, high moisture, and high load.	- Check food interferes with door closing. - Check ice on the ceilings.	- Be acquainted with how to use.	

# TROUBLE DIAGNOSIS

Problems	Causes	Checks	Measures	Remarks
Ice in the freezer compartment. - Surface of fan grille. - Wall of freezer compartment. - Cool air discharging port. - Basket(rack) area.	1) Bad cooling air circulation. - Intake port is clogged in the freezer compartment. - Discharging port is Clogged. - Too much food is stored. - Bad defrosting.	- Check food storage conditions visually.(Check clogging at intake and discharging port of cooling air.) - Check food occupation ratio in volume(Less than 75%). - Check frost on the evaporator after dissembling shroud and fan grille. - Check icing at intake port of refrigerator compartment.	- Be acquainted with how to use. - Check defrost (Check ice on the evaporator and pipes after forced defrosting).	- Check the parts related to defrosting if the problem is caused by the faulty defrosting.
- Food surface. - Icing in the shute.	2) Bad freezer compartment door - Faulty gasket - Faulty assembly	- Check gasket attachment conditions. - Check door assembly conditions.	- Correct the gasket attachment conditions and replace it. - Door assembly and replacement.	- Replace when it can not be repaired.
	3) Over freezing in the freezer compartment. - Faulty MICOM.	- Refrigerator operates pull down. (Check if it is operated intermittently) - The Temperature of freezer compartment is satisfactory, but over freezing happens in the refrigerator compartment even though the notch is set at "weak".	-Replace defective parts.	
	4) Bad defrosting. - Heater wire is cut. - Faulty defrost sensor. - Defrosting cycle	- Check frost on the evaporator after dissembling shroud and grille. - Check ice on the intake port in the refrigerator compartment.	- Check parts related to defrosting. - Check defrosting.(Check ice on the evaporator and pipes after forced defrosting.)	
	5) User is not familiar with how to use. - Door opens. - High moisture food(water) is stored.	- Check food holds door open. - Check ice on the ice tray.	- Be acquainted with how to use.	

## 2-7. Sound

Problems	Causes	Checks	Measures	Remarks
"Whizz" sound	1. Loud sound of compressor operation.	<p>1.1 Check the level of the refrigerator.</p> <p>1.2 Check the rubber seat conditions (sagging and aging).</p>	<p>1) Maintain horizontal level.</p> <p>2) Replace rubber and seat if they are sagged and aged.</p> <p>3) Insert rubber where hand contact reduces noise in the pipe.</p> <p>4) Avoid pipe interference.</p> <p>5) Replace defective fan and fan motor.</p> <p>6) Adjust fan to be in the center of bell mouth of the fan guide.</p> <p>7) Leave a clearance between interfering parts and seal gaps in the structures.</p> <p>8) Reassemble the parts which make sound.</p> <p>9) Leave a clearance if evaporator pipes and suction pipe touch freezer shroud.</p>	
	2. Pipes resonant sound which is connected to the compressor.	<p>2.1 Check the level of pipes connected to the compressor and their interference.</p> <p>2.2 Check rubber inserting conditions in pipes.</p> <p>2.3 Touch pipes with hands or screw -driver (check the change of sound).</p>		
	3. Fan operation sound in the freezer compartment.	<p>3.1 Check fan insertion depth and blade damage.</p> <p>3.2 Check the interference with structures.</p> <p>3.3 Check fan motor.</p> <p>3.4 Check fan motor rubber insertion and aging conditions.</p>		
	4. Fan operation sound in the compressor compartment.	<p>4.1 Same as fan confirmation in the refrigerator.</p> <p>4.2 Check drip tray leg insertion.</p> <p>4.3 Check the screw fastening conditions at condenser and drip tray.</p>		

# TROUBLE DIAGNOSIS

Problems	Causes	Checks	Measures	Remarks
Vibration sound. ("Cluck")	<ol style="list-style-type: none"> <li>1. Vibration of shelves and foods in the refrigerator.</li> <li>2. Pipes interference and capillary tube touching in the compressor compartment.</li> <li>3. Compressor stopper vibration.</li> <li>4. Moving wheel vibration.</li> <li>5. Other structure and parts vibration.</li> </ol>	<ol style="list-style-type: none"> <li>1-1. Remove and replace the shelves in the refrigerator</li> <li>1-2. Check light food and container on the shelves.</li> <li>2-1. Touch pipes in the compressor compartment with hands.</li> <li>2-2 Check capillary tube touches cover back.</li> <li>3-1 Check compressor stopper vibration.</li> <li>4-1 Check vibration of front and rear moving wheels.</li> <li>5-1 Touch other structures and parts.</li> </ol>	<ol style="list-style-type: none"> <li>1) Reassemble the vibrating parts and insert foam or cushion where vibration is severe.</li> <li>2) Leave a clearance where parts interfere with each other.</li> <li>3) Reduce vibration with rubber and restrainer if it is severe. (especially, compressor and pipe).</li> <li>4) Replace compressor stopper if it vibrates severely.</li> </ol>	
Irregular sound. ("Click").	<ol style="list-style-type: none"> <li>1. It is caused by heat expansion and contraction of evaporator, shelves, and pipes in the refrigerator.</li> </ol>	<ol style="list-style-type: none"> <li>1-1 Check time and place of sound sources.</li> </ol>	<ol style="list-style-type: none"> <li>1) Explain the principles of refrigeration and that the temperature difference between operation and defrosting can make sounds.</li> <li>2) If evaporator pipe contacts with other structures, leave a clearance between them (freezer shroud or inner case).</li> </ol>	

Problems	Causes	Checks	Measures	Remarks
Sound "Burping" (almost the same as animals crying sound).	It happens when refrigerant expands at the end of capillary tube.	<ul style="list-style-type: none"> <li>- Check the sound of refrigerant at the initial installation.</li> <li>- Check the sound when the refrigerator starts operation after forced defrosting.</li> <li>- Check the restrainer attachment conditions on the evaporator and capillary tube weld joints.</li> </ul>	<ul style="list-style-type: none"> <li>- Check the restrainer attached on the evaporator and capillary tube weld joints and attach another restrainer.</li> <li>- If it is continuous and severe, insert capillary tube again (depth: 15±3mm)</li> <li>- Fasten the capillary tube to suction pipes or detach in the compressor compartment.</li> <li>- Explain the principles of freezing cycles.</li> </ul>	
Water boiling or flowing sound.	It happens when refrigerant passes orifice in accumulator internal pipes by the pressure difference between condenser and evaporator.	<ul style="list-style-type: none"> <li>- Check the sound when compressor is turned on.</li> <li>- Check the sound when compressor is turned off.</li> </ul>	<ul style="list-style-type: none"> <li>- Explain the principles of freezing cycles and refrigerant flowing phenomenon by internal pressure difference.</li> <li>- If sound is severe, wrap the accumulator with foam and restrainer.</li> </ul>	
Sound of whistle when door closes.	When door closes, the internal pressure of the refrigerator decreases sharply below atmosphere and sucks air into the refrigerator, making the whistle sound.	<ul style="list-style-type: none"> <li>- Check the sound by opening and closing the refrigerator or freezer doors.</li> </ul>	<ul style="list-style-type: none"> <li>- Broaden the cap of discharge hose for defrosting in the compressor compartment.</li> <li>- Seal the gap with sealant between out and inner cases of hinge in door.</li> </ul>	



# TROUBLE DIAGNOSIS

## 2-8. Odor

Problems	Causes	Checks	Measures	Remarks
Food Odor.	Food (garlic, kimchi, etc)	<ul style="list-style-type: none"> <li>- Check the food is not wrapped.</li> <li>- Check the shelves or inner wall are stained with food juice.</li> <li>- Check the food in the vinyl wraps.</li> <li>- Check food cleanliness.</li> </ul>	<ul style="list-style-type: none"> <li>- Dry deodorizer in the shiny and windy place.</li> <li>- Store the food in the closed container instead of vinyl wraps.</li> <li>- Clean the refrigerator and set button at "strong" .</li> </ul>	
Plastic Odor.	Odors of mixed food and plastic odors.	<ul style="list-style-type: none"> <li>- Check wet food is wrapped with plastic bowl and bag.</li> <li>- It happens in the new refrigerator.</li> </ul>	<ul style="list-style-type: none"> <li>- Clean the refrigerator.</li> <li>- Persuade customers not to use plastic bag or wraps with wet food or odorous foods.</li> </ul>	
Odor from the deodorizer.	Odor from the old deodorizer.	<ul style="list-style-type: none"> <li>- Check the deodorizer odors.</li> </ul>	<ul style="list-style-type: none"> <li>- Dry the deodorizer with dryer and then in the shiny and windy place.</li> <li>- Remove and replace the deodorants.</li> </ul>	*Deodorizer : option

# TROUBLE DIAGNOSIS

## 2-9. Micom

Problems	Symptom	Causes	Checks	Measures	Remarks
Bad PCB electric power.	All display LEDS are off.	Bad connector connection from main PCB to display PCB.	Visual check on connector connection.	Reconnect connector.	
		Defective PCB trans.	Check resistance of PCB Trans input and output terminals with a tester. (If resistance is infinity, trans winding is cut).	Replace PCB Trans or PCB.	Applicable to model without dispenser.
Abnormal display LED operation	Defective LED module.	Defective regulator IC (7812, 7805).	Check voltage at input/output terminals.	Replace regulator.	Refer to electric circuit in circuit explanation.
		PCB electric terminal fuse is burnt out.	Check fuse in PCB electric terminal with a tester.	Replace PCB fuse.	
		STR Parts are damaged.	Check if STR No. 2 and 3 pins are cut when power is off.	Replace parts.	Applicable to model with dispenser.
		Lead Wire connecting main PCB and display PCB is cut or connector terminal connection is bad.	Check Lead Wire terminals connecting Main PCB and display PCB with a tester.	Reconnect Lead Wire and directly connect defective contact terminal to Lead Wire.	
		Defective LED.	Check if all LEDs are on when Main PCB Test switch is pressed (or when both freezer key and power freezer key are pressed at the same time for more than one second.)	Replace display PCB.	Refer to display circuit in circuit explanation.

# TROUBLE DIAGNOSIS

Problems	Symptom	Causes		Checks	Measures	Remarks
Bad cooling.	Freezer temperature is high.	Compressor does not start.	Compressor Lead Wire is cut.	Check compressor Lead Wire with a tester.	Reconnect Lead Wire.	
			Defective compressor driving relay.	Measure voltage at PCB CON5 (3&9) after pressing main PCB test switch once. It is OK if voltage is normal.	Replace relay(RY1 and RY14) or PCB.	Refer to load driving circuit in circuit explanation.
		Defective freezer sensor.	Defective Freezer sensor parts.	Check resistance of freezer sensor with a tester.	Replace freezer sensor.	Refer to resistance characteristics table of sensor in circuit explanation.
			Freezer sensor is substituted for other sensor.	Confirm the color of sensor in circuits (main PCB sensor housing).	Repair main PCB sensor housing	
Defective freezer fan motor.	Fan motor lead wire is cut.	Fan motor lead wire is cut.	Check fan motor lead wire with a tester.	Reconnect lead wire.		
		<ul style="list-style-type: none"> <li>Defective door switch (freezer, refrigerator, home bar).</li> <li>Defective fan motor.</li> <li>Defective fan motor driving relay.</li> </ul>	Measure the voltage between PCB power blue line and fan motor after pressing test switch of Main PCB. If the voltage is normal, it is OK.	<ul style="list-style-type: none"> <li>Replace door switch (freezer, refrigerator and home bar).</li> <li>Replace fan motor.</li> <li>Replace relay(RY5 &amp; RY6) or PCB.</li> </ul>	Refer to load driving circuits in circuit explanation.	
	Faulty defrost.		Refer to faulty defrost items in trouble diagnosis functions.			Refer to trouble diagnosis function.

# TROUBLE DIAGNOSIS

Problems	Symptom	Causes	Checks	Measures	Remarks	
Bad cooling	Wrong Refrigerator temperature.	Defective AC Damper.	Check AC damper motor and reed switch and lead wire are cut.	Reconnect lead wire.		
			Check AC damper part.	Refer to AC damper in parts repair guide.	Replace AC damper or refrigerator control box Assy.	
		Defective AC damper Motor driving relay in PCB.	Check AC damper	Refer to AC damper in parts repair guide.	Replace relay or PCB.	Refer to single motor damper driving circuits in circuit explanation.
			Motor driving relay in PCB.	Refer to AC damper in parts repair guide.		
		Foreign materials in AC damper baffles	Check AC damper	Check AC damper baffle visually.	Remove foreign materials.	
			Ice formation on AC damper baffles	Check if AC damper Heater wire is cut with a tester.	Replace AC damper or refrigerator control Box Assy.	
		Defective refrigerator sensor	Defective refrigerator sensor parts.	Check the resistance of refrigerator sensor with a tester.	Replace refrigerator sensor.	Refer to sensor resistance characteristic table in circuit explanation.
				Refrigerator sensor is substituted for other sensor.	Repair main PCB sensor housing.	
		Defective refrigerator sensor assembly condition.	Defective refrigerator sensor assembly condition.	Check if refrigerator sensor is not fixed at cover sensor but inner case visually.	Fix again the refrigerator sensor.	

# TROUBLE DIAGNOSIS

Problems	Symptom	Causes	Checks	Measures	Remarks
Bad defrost.	Defrost is not working.	Defrost lead wire is cut.	Check if defrost lead wire is cut with a tester.	Reconnect Lead Wire.	
		Defective defrost driving relay.	Check the voltage of CON5 (1 and 7) with a tester after pressing main PCB test switch twice. If the voltage is normal then it is OK.	Replace relay (RY 7 and RY 14) or PCB.	Refer to load driving conditions check in circuit explanation.
Defective buzzer	Buzzer continuously rings or door opening alarm does not work.	Defective defrost sensor parts.	Check the resistance of defrost sensor with a tester.	Replace defrost sensor.	Refer to sensor resistance characteristic table of circuit explanation.
		Defective connecting lead wire from main PCB to door switch. Defective door switch parts.	Check lead wire related to door switch with a tester. Refer to door switch in parts repair guide.	Repair lead wire. Replace door switch.	
Defective display button	Buzzer does not ring and key does not sense even button is pressed.	Key input wire is cut or bad connector terminal contact in main PCB and display PCB connecting lead wire.	Check input wire with a tester.	Reconnect lead wire and replace or directly connect bad contact terminal to lead wire.	Refer to display circuit in circuit explanation.
		Key is continuously depressed due to structural interference.	Disassemble frame display and confirm visually.	Adjust or replace interfering structures.	

# TROUBLE DIAGNOSIS

Problems	Symptom	Causes	Checks	Measures	Remarks
Defective display button.	Buzzer rings but key does not sense even button is pressed.	Trouble mode indication.	Check trouble diagnosis function.	Repair troubles	Refer to mode indication in function explanations.
Door Buzzer	Buzzer continuously rings or door opening alarm does not work.	Defective connecting lead wire from main PCB to door switch.	Check lead wire associated with door switch.	Repair lead wire.	Check model with dispenser.
		Defective freezer compartment door switch parts.	Refer to door switch in parts repair guide.	Replace Freezer compartment door switch.	
Bad water/ice dispenser.	Ice and water are not dispensed.	Defective connecting lead wire from Main PCB to lever switch.	Check Lead Wire associated with lever switch with a tester.	Repair lead wire.	
		Defective lever switch parts	Refer to door switch in parts repair guide.	Replace lever switch.	
		Defective photo coupler IC parts.	Check voltage change at photo coupler output terminals with lever switch pressed. It is OK if voltage change is between 0V - 5V.	Replace photo coupler IC or PCB.	
		Defective relay associated with ice dispense (gearing motor, cube and dispenser solenoid).	Check relay (RY9, RY11, RY12) with a tester.	Replace defective relay.	
		Defective parts associated with ice dispense (gearing motor, cube and dispenser solenoid).	Check resistance of parts with a tester.	Replace defective parts.	
		Defective relay associated with water dispense.	Check relay (RY10) with a tester	Replace defective relay.	
	Defective parts associated with water dispenser.	Check resistance of parts with a tester.	Replace defective parts with a tester.	Replace defective parts.	

# TROUBLE DIAGNOSIS

## 3. Cooling Cycle Heavy Repair









### 3-1. The Heavy Repair Standards for Refrigerator with R134a Refrigerant

NO.	Items	Unit	Standards	Purposes	Remarks	
1	Pipe and piping system opening time.	Min.	Pipe:within 1 hour. Comp:within 10 minutes. Drier:within 20 minutes.	To protect Moisture Penetration.	The opening time should be reduced to a half of the standards during rain and rainy seasons (the penetration of water into the pipe is dangerous).	
2	Welding.	Nitrogen Pressure.	Weld under Nitrogen atmosphere (N <sub>2</sub> pressure: 0.1~0.2 kg/cm <sup>2</sup> )	To protect oxide scale formation.	- Refet to repair note in each part. - R134a refrigerant is more susceptible to leaks than R12 and requires more care during welding. - Do not apply force to pipes before and after welding to protect pipe from cracking.	
3	N <sub>2</sub> sealed parts.	Confirm N <sub>2</sub> leak.	Confirm air leaking sounds when removing rubber cap. Sound:usable No sound:not usable	To protect moisture penetration.	- In case of evaporator parts, if it doesn't noise when removing rubber cap blow dry air or N <sub>2</sub> gas for more than 1 min use the parts.	
4	Refrigeration Cycle.	Evacuation time	Min.	More than 40 minutes.	To remove moisture.	Note:Only applicable to the model equipped with reverse flow protect plate.  Vaccum efficiency can be improved by operating compressor during evacuation.  The rubber pipes for R12 refrigerant shall be melted when they are used for R134a refrigerant(causes of leak).
		Vacuum degree	Torr	Below 0.03(ref)		
		Vacuum	EA	High and low Pressure sides are evacuated at the same time for models above 200ℓ		
		Vacuum piping	EA	Use R134a exclusive manifold.	To protect mixing of mineral and ester oils.	
		Pipe coupler	EA	Use R134a cxclusive.	To protect R12 Refrigerant mixing.	
		Outlet (Socket) Plug		R134a exclusive. R134a exclusive	" "	
5	Refrigerant weighing.	EA	Use R134a exclusively. Weighing allowance:±5g Note:Winter:-5g Summer:+5g	Do not mix with R12 refrigerant.	- Do not weight the refrigerant at too hot or too cold an area.(25°C is adequate.) - Use copper bombe Socket:2SV Plug: 2PV R134a Note:Do not burn O-ring (rubber) during welding.	
6	Drier replacement.		-Use R134a exclusively for R134a refrigerator -Use R12 exclusively for R12 refrigerator -Replace drier whenever repairing refrigerator cycle piping.	To remove the moisture from pipe.		
7	Leak check.		-Do not use soapy water for check. it may be sucked into the pipe by.	Detect refrigerant leak area.	-Check oil leak at refrigerant leak area. Use electronic leak detector if oil leak is not found. -The electronic leak detector is very sensitive to halogen gas in the air. It also can detect R141b in urethane. Please practice, therefore, many times before use.	

**NOTE)** Please contact Songso company on +82-53-554-2067 if you have inquiry on heavy repair special facility.

# TROUBLE DIAGNOSIS

## 3-2. Summary Of Heavy Repair

Process	Contents	Tools
		
	<ul style="list-style-type: none"> <li>- Cut charging pipe ends and discharge refrigerant from drier and compressor.</li> </ul>	Filter, side cutters
	<ul style="list-style-type: none"> <li>- Use R134a oil and refrigerant for compressor and drier</li> <li>- Confirm N<sub>2</sub> sealing and packing conditions before use. Use good one for welding and assembly.</li> <li>- Weld under nitrogen gas atmosphere.(N<sub>2</sub> gas pressure: 0.1-0.2kg/cm<sup>2</sup>).</li> <li>- Repair in a clean and dry place.</li> </ul>	Pipe Cutter, Gas welder, N <sub>2</sub> gas
	<ul style="list-style-type: none"> <li>- Evacuate for more than forty minutes after connecting manifold gauge hose and vacuum pump to high (drier) and low (compressor refrigerant discharging parts) pressure sides.</li> <li>- Evacuation Speed:113l/min.</li> </ul>	Vacuum pump(R134a exclusively), Manifold gauge.
	<ul style="list-style-type: none"> <li>- Weigh and control the allowance of R134a bombe in a vacuum conditions to be ±5 g with electronic scales and charge through compressor inlet (Charge while refrigerator operates).</li> <li>- Weld carefully after inlet pinching.</li> </ul>	R134a exclusive bombe(mass cylinder), refrigerant(R134a) manifold gauge, electronic scales, punching off flier, gas welding machine
	<ul style="list-style-type: none"> <li>- Check leak at weld joints.               <ul style="list-style-type: none"> <li>□ Minute leak: Use electronic leak detector</li> <li>□ Big leak: Check visually or fingers.</li> </ul> </li> <li>Note:Do not use soapy water for check.</li> <li>- Check cooling capacity               <ol style="list-style-type: none"> <li>① Check radiator manually to see if warm.</li> <li>② Check hot line pipe manually to see if warm.</li> <li>③ Check frost formation on the whole surface of the evaporator.</li> </ol> </li> </ul>	Electronic Leak Detector, Driver(Ruler).
	<ul style="list-style-type: none"> <li>- Remove flux from the silver weld joints with soft brush or wet rag.(Flux may be the cause of corrosion and leaks.)</li> <li>- Clean R134a exclusive tools and store them in a clean tool box or in their place.</li> </ul>	Copper brush, Rag, Tool box
	<ul style="list-style-type: none"> <li>- Installation should be conducted in accordance with the standard installation procedure.(Leave space of more than 5 cm from the wall for compressor compartment cooling fan mounted model.)</li> </ul>	



# TROUBLE DIAGNOSIS

## 3-3. Precautions During Heavy Repair

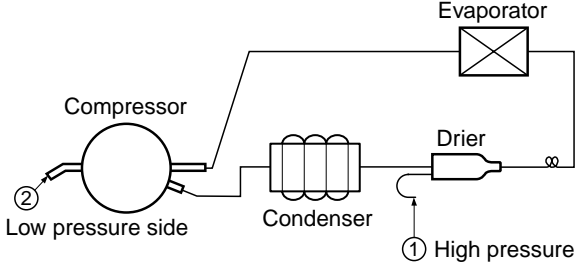
Items	Precautions
1. Use of tools.	1) Use special parts and tools for R134a.
2. Removal of retained refrigerant.	<p>1) Remove retained refrigerant more than 5 minutes after turning off a refrigerator. (If not, oil will leak inside.)</p> <p>2) Remove retained refrigerant by cutting first high pressure side (drier part) with a nipper and then cut low pressure side. (If the order is not observed, oil leak will happen.)</p>  <p>The diagram illustrates a refrigeration cycle with the following components and connections:         <ul style="list-style-type: none"> <li><b>Compressor:</b> A circular component on the left with two ports. The lower port is labeled 'Low pressure side' with a circled '2' and an arrow pointing to it.</li> <li><b>Condenser:</b> A coil of pipes located between the compressor and the drier.</li> <li><b>Drier:</b> A cylindrical component located between the condenser and the evaporator. The upper port is labeled 'High pressure side' with a circled '1' and an arrow pointing to it.</li> <li><b>Evaporator:</b> A rectangular component with an 'X' inside, located on the right side of the cycle.</li> </ul>         The pipes connect the compressor to the condenser, the condenser to the drier, the drier to the evaporator, and the evaporator back to the compressor.       </p>
3. Replacement of drier.	1) Be sure to replace drier with R134a only when repairing pipes and injecting refrigerant.
4. Nitrogen blowing welding.	1) Weld under nitrogen atmosphere in order to prevent oxidation inside a pipe. (Nitrogen pressure : 0.1~0.2 kg/cm <sup>2</sup> .)
5. Others.	<p>1) Nitrogen or refrigerant R134a only should be used when cleaning inside of cycle pipes inside and sealing.</p> <p>2) Check leakage with an electronic leakage tester.</p> <p>3) Be sure to use a pipe cutter when cutting pipes.</p> <p>4) Be careful not the water let intrude into the inside of the cycle.</p>

# TROUBLE DIAGNOSIS

## 3-4. Practical Work For Heavy Repair

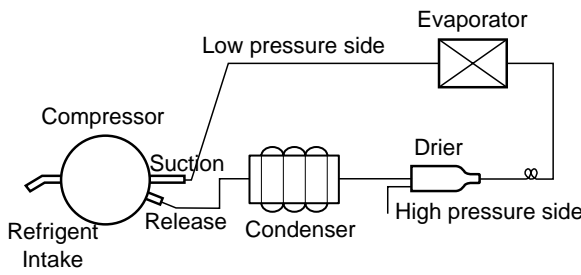
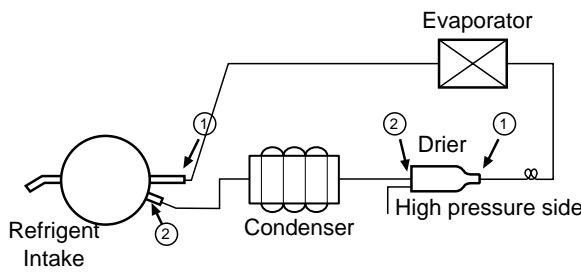
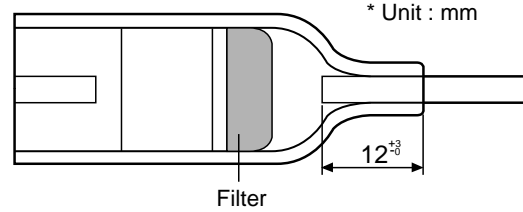
Items	Precautions
<p>1. Removal of residual refrigerant.</p>	 <p><b>KEYPOINTING</b> Observe the sequence for removal of refrigerant. (If not, compressor oil may leak.)</p> <ol style="list-style-type: none"> <li>1) Remove residual refrigerant more than 5 minutes later after turning off the refrigerator. (If not, compressor oil may leak inside.)</li> <li>2) Remove retained refrigerant slowly by cutting first high pressure side (drier part) with a nipper and then cut low pressure side.</li> </ol>
<p>2. Nitrogen blowing welding.</p>	 <p><b>KEYPOINTING</b> Welding without nitrogen blowing produces oxidized scales inside a pipe, which affect on performance and reliability of a product.</p> <p><b>When replacing a drier:</b> Weld ① and ② parts by blowing nitrogen (0.1~0.2kg/cm<sup>2</sup>) to high pressure side after assembling a drier.</p> <p><b>When replacing a compressor:</b> Weld ① and ② parts by blowing nitrogen to the low pressure side.</p> <p>Note) For other parts, nitrogen blowing is not necessary because it does not produce oxidized scales inside pipe because of its short welding time.</p>
<p>3. Replacement of drier.</p>	 <p><b>KEYPOINTING</b> Be sure to check the inserted length of capillary tube when it is inserted. (If too much inserted, a capillary tube is clogged by a filter.)</p> <p><b>Inserting a capillary tube</b> Measure distance with a ruler and put a mark (12<sup>+3/0</sup>) on the capillary tube. Insert tube to the mark, and weld it</p>

# TROUBLE DIAGNOSIS

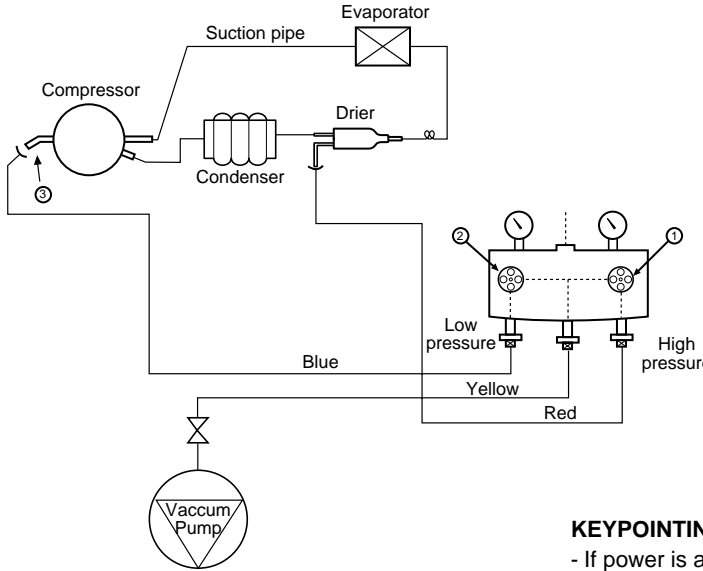
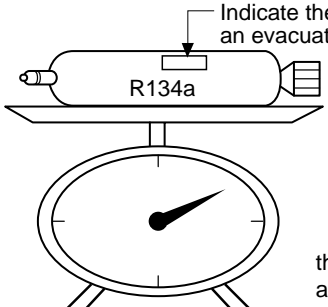
Items	Precautions
<p>4.Vacuum degassing.</p>	<div style="text-align: center;">  </div> <p><b>KEYPOINTING</b></p> <ul style="list-style-type: none"> <li>- If power is applied during vacuum degassing, vacuum degassing shall be more effective.</li> <li>- Operate compressor while charging refrigerant. (It is easier and more certain to do like this.)</li> </ul> <p><b>Pipe Connection</b> Connect a red hose to the high pressure side and a blue hose to the low pressure side.</p> <p><b>Vacuum Sequence</b> Open ①, ② valves and evacuate for 40 minutes. Close valve ①.</p>
<p>5.Refrigerant charging.</p>	<p><b>Charging sequence</b></p> <ol style="list-style-type: none"> <li>1) Check the amount of refrigerant supplied to each model after completing vacuum degassing.</li> <li>2) Evacuate bombe with a vacuum pump.</li> <li>3) Measure the amount of refrigerant charged. <ul style="list-style-type: none"> <li>- Measure the weight of an evacuated bombe with an electronic scale.</li> <li>- Charge refrigerant into a bombe and measure the weight. Calculate the weight of refrigerant charged into the bombe by subtracting the weight of an evacuated bombe.</li> </ul> </li> </ol> <div style="text-align: center;">  </div> <p><b>KEYPOINTING</b></p> <ul style="list-style-type: none"> <li>- Be sure to charge the refrigerant at around 25°C.</li> <li>- Be sure to keep -5g in the winter and +5g in summer</li> </ul> <div style="border: 1px solid black; padding: 5px; width: fit-content; margin: 10px auto;"> <p><b>Calculation of amount of refrigerant charged</b></p> </div> <p>the amount of refrigerant charged= a weight after charging - a weight before charging (a weight of an evacuated cylinder)</p>

# TROUBLE DIAGNOSIS

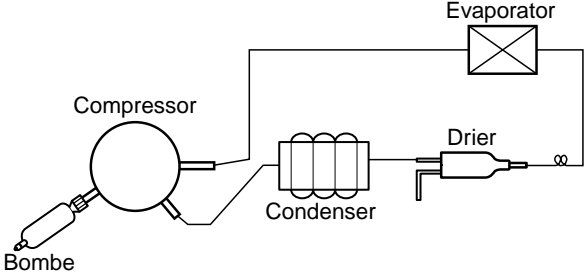
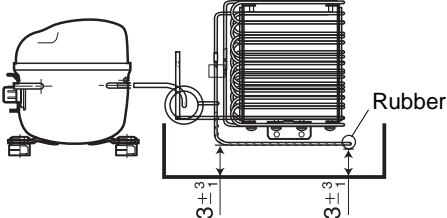
Items	Precautions
	<div style="text-align: center;">  </div> <p>4) Refrigerant Charging Charge refrigerant while operating a compressor as shown above.</p> <p>5) Pinch a charging pipe with a pinch-off plier after completion of charging.</p> <p>6) Braze the end of a pinched charging pipe with copper brazer and take a gas leakage test on the welded parts.</p>
6. Gas-leakage test	* Take a leakage test on the welded or suspicious area with an electronic leakage tester.
7. Pipe arrangement in each cycle	<p>Check each pipe is placed in its original place before closing a cover back-M/C after completion of work. Particularly control the size of Joint Drain Pipe</p> <div style="text-align: center;">  </div>

## 3-5. Standard Regulations For Heavy Repair

- 1) Observe the safety precautions for gas handling.
- 2) Use JIG (or wet towel) in order to prevent electric wires from burning during welding. (In order to prevent insulation break and accident.)
- 3) The inner case shall be melted and insulation material (polyurethane) shall be burnt if not cared during welding inner case parts.
- 4) The copper pipe shall be oxidized by overheating if not cared during welding.
- 5) Not allow the aluminum pipes to contact to copper pipes. (In order to prevent corrosion.)
- 6) Observe that the inserted length of a capillary tube into a drier should be  $12^{+3}$ mm.

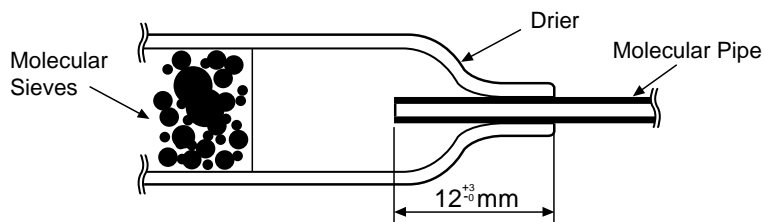

- 7) Make sure that the inner diameter should not be distorted while cutting a capillary tube.
- 8) Be sure that a suction pipe and a filling tube should not be substituted each other during welding. ( High efficiency pump.)

# TROUBLE DIAGNOSIS

## 3-6. Brazing Reference Drawings

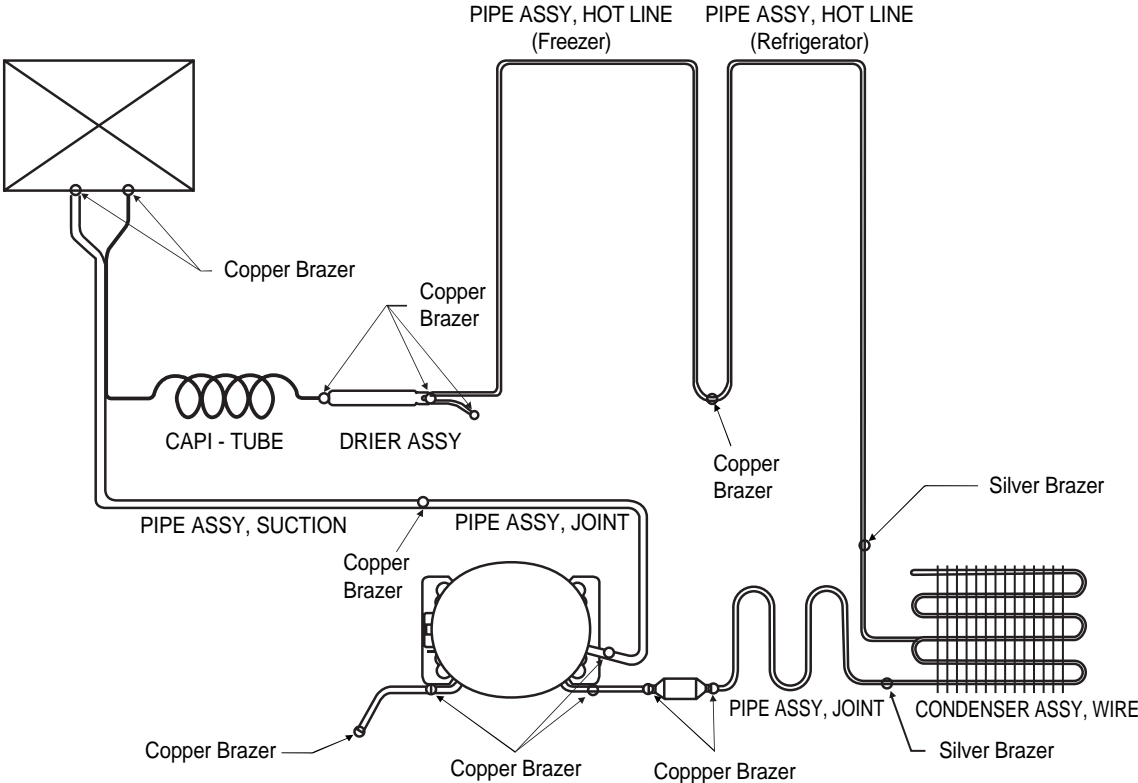

# TROUBLE DIAGNOSIS

## 4. HOW TO DEAL WITH CLAIMS

### 4-1. Sound

Problems	Checks and Measures
"Whizz" sounds	<p>■ <b>Explain general principles of sounds.</b></p> <ul style="list-style-type: none"> <li>• All refrigerator when functioning properly have normal operating sound. The compressor and fan produce sounds. There is a fan in the freezer compartment which blows cool air to freezer and refrigerator compartments. "Whizz" sounds are heard when the air passes through the narrow holes into the freezer and refrigerator compartments.</li> </ul> <p>■ <b>Cooling Fan sound in the compressor compartment.</b></p> <ul style="list-style-type: none"> <li>• There is a fan on the back of the refrigerator, which cools the compressor compartment. If there is a small space between the refrigerator and the wall, the air circulation sounds may be noticeable.</li> </ul> <p>■ <b>Noise of Compressor.</b></p> <ul style="list-style-type: none"> <li>• This operating sound happens when the compressor compresses the refrigerant. The compressor rotates at 3600RPM. The sound of compressor operation becomes louder as the refrigerator capacity increases.</li> </ul>
"Click" sounds	<p>■ <b>Explain the principles of temperature change.</b></p> <ul style="list-style-type: none"> <li>• The sounds happens when pipes and internal evaporator in the refrigerator compartment expand and contract as the temperature changes during the refrigerator operation. This sound also happens during defrosting, twice a day, when the ice on the evaporator melts.</li> </ul>
"Clunk" sound	<p>■ <b>Explain that it comes from the compressor when the refrigerator starts.</b></p> <ul style="list-style-type: none"> <li>• When the refrigerator operates, the piston and motor in the compressor rotate at 3600RPM. This sound is caused by the vibration of motor and piston when they start and finish their operation. This phenomena can be compared with that of cars. When the car engine ignites and starts to rotate, the loud sound becomes gradually quiet. When the engine stops, it stops with vibration.</li> </ul>
Vibration sound	<p>■ <b>Check the sound whether it comes from the pipes vibration and friction.</b></p> <ul style="list-style-type: none"> <li>• Insert rubber or leave a space between pipes to avoid the noise.</li> <li>• Fix the fan blade if the noise is due to the collision of fan and shroud.</li> <li>• Fix the drip tray if it is loosened.</li> </ul> <p>■ <b>Sound depends on the installation location.</b></p> <ul style="list-style-type: none"> <li>• Sound becomes louder if the refrigerator is installed on a wooden floor or near a wooden wall. Move it to the another location.</li> <li>• If the refrigerator is not leveled properly, a small vibration can make a loud sound. Please adjust the level of the refrigerator.</li> </ul>

# TROUBLE DIAGNOSIS

Problems	Checks and Measures
Sounds of water flowing	<p>■ <b>Explain the flow of refrigerant.</b></p> <ul style="list-style-type: none"> <li>• When the refrigerator stops, the water flowing sound happens. This sound happens when the liquid or vapor refrigerant flows from the evaporator to compressor.</li> </ul>
"Click" sounds	<p>■ <b>Explain the characteristics of moving parts.</b></p> <ul style="list-style-type: none"> <li>• This noise comes from the MICOM controller's switch on the top of the refrigerator when it is turned on and off.</li> </ul>
Noise of ice maker operation (applicable to model with ice maker). - Noise produced by ice dropping and hitting ice bank. - Noise from motor sounds "Whizz".	<p>■ <b>Explain the procedure and principles of ice maker operation.</b></p> <ul style="list-style-type: none"> <li>• Automatic ice maker repeats the cycle of water supplying → icemaking → ice ejection. When water is supplied, the water supply valve in the machine room makes sounds like "Whizz" and water flowing also makes sound. When water freezes to ice, freezing sounds such as "click, click" are heard. When ice is being ejected, sounds like "Whizz" produced by a motor to rotate an ice tray and ice dropping and hitting ice bank sounds are also heard.</li> </ul>
Noise when supplying water.	<p>■ <b>Explain the principles of water supplied to dispenser.</b></p> <ul style="list-style-type: none"> <li>• When the water supply button in the dispenser is pressed, the water supply valve in the compressor compartment opens and let the water flow to the water tank in the lower part of the refrigerator compartment. The water is dispensed by this pressure. When this happens, motor sound and water flowing sound are heard.</li> </ul>
Noise when supplying ice.	<p>■ <b>Explain the principles of ice supply and procedure of crushed ice making in a dispenser.</b></p> <ul style="list-style-type: none"> <li>• When ice cube button is pressed, ice stored in the ice bank is moved by a Helix Pusher and dispensed. If crushed ice button is pressed, the cube ice is crushed. When this happens, ice crushing and hitting ice bank sounds are heard.</li> </ul>

# TROUBLE DIAGNOSIS

## 4-2. Measures for Symptoms on Temperature

Problems	Checks and Measures
Refrigeration is weak.	<p>■ <b>Check temperature set in the temperature control knob.</b></p> <ul style="list-style-type: none"> <li>• Refrigerator is generally delivered with the button set at “normal use” (MID). But customer can adjust the temperature set depending on their habit and taste. If you feel the refrigeration is weak, then set the temperature control button at “strong” position. If you adjust the button in the freezer compartment as well, the refrigeration is stronger than adjusting refrigerator only.</li> </ul>
The food in the chilled drawer is . not frozen but defrosted	<p>■ <b>The chilled drawer does not freeze food.</b></p> <ul style="list-style-type: none"> <li>• Use chilled drawer for storing fresh meat or fish for short periods. For storing for a long periods or freezing food, use a freezer compartment. It is normal that frozen foods thaw above the freezing temperature (in the chilled drawer).</li> </ul>
Refrigerator water is not cool.	<p>■ <b>Check the water storage location.</b></p> <ul style="list-style-type: none"> <li>• If water is kept in the door rack, please ask to keep it in the refrigerator compartment shelf. It will then become cooler.</li> </ul>
Ice cream softens.	<p>■ <b>Explain the characteristics of ice cream.</b></p> <ul style="list-style-type: none"> <li>• The freezing point of ice cream is below -15°C. Therefore ice cream may melt if it is stored in the door rack.</li> <li>• Store ice cream in a cold place or set the temperature control button of a freezer at “strong” position.</li> </ul>
Refrigeration is too strong.	<p>■ <b>Check the position of temperature control button.</b></p> <ul style="list-style-type: none"> <li>• Check if refrigeration is strong in whole area of the refrigerator or partly near the outlet of the cooling air. If it is strong in whole area, set the control button at “weak”. If it is strong only near the outlet of cool air, keep food (particularly wet and easy to frozen such as bean curd and vegetables) away from the outlet.</li> </ul>
Vegetables are frozen.	<p>■ <b>Check the vegetables storage.</b></p> <ul style="list-style-type: none"> <li>• If vegetables are stored in the refrigerator shelf or chilled drawer instead of vegetable drawer, they will be frozen. Set the control button at “weak” if they are also frozen in the vegetable drawer.</li> </ul>
The food stored at inside of the shelf freezes even the control button is set at “MID”.	<p>■ <b>Check if food is stored near the outlet of the cooling air.</b></p> <ul style="list-style-type: none"> <li>• The temperature at cooling air outlet is always below the freezing point. Do not store food near the outlet of the cooling air as it block the air circulation. And do not block the outlet. If the outlet of the cooling air is blocked, the refrigerator compartment will not be cooled.</li> </ul>



# TROUBLE DIAGNOSIS

## 4-3. Odor and Frost

Problems	Checks and Measures
Odor in the refrigerator compartment.	<p>■ <b>Explain the basic principles of food odor.</b></p> <ul style="list-style-type: none"> <li>• Each food has its own peculiar odor. Therefore it is impossible to prevent or avoid food odor completely when food is stored in the completely sealed refrigerator compartment. Deodorizer can absorb some portions of the odor but not completely. The intensity of odor depends on refrigerator conditions and environments.</li> </ul> <p>■ <b>Check the temperature control button and set at “strong”.</b></p> <ul style="list-style-type: none"> <li>• Clean inside of the refrigerator with detergent and remove moisture. Dry inside the refrigerator by opening the door for about 3 or 4 hours and then set the temperature control button at “strong”.</li> </ul>
Frost in the freezer compartment	<p>■ <b>Explain the basic principles of frost formation.</b></p> <ul style="list-style-type: none"> <li>• The main causes for frosting:               <ul style="list-style-type: none"> <li>- Door was left open.</li> <li>- Air penetration through the gasket</li> <li>- Too frequent door opening. (parties. etc.)</li> <li>- Hot foods are stored before they are cooled down. The temperature of freezer is -19°C. if temperature is set at “MID”. If hot air comes into the refrigerator, fine frost forms as cold air mixes with hot air. If this happens quite often, much frost forms inside of the refrigerator. If the door is left open in Summer, ice may form inside of the refrigerator.</li> </ul> </li> </ul>
Frost in ice tray.	<p>■ <b>Explain basic principles of frost formation.</b></p> <ul style="list-style-type: none"> <li>• When ice tray with full of water is put into a freezer compartment, the water evaporates. If cool air fan operates, the moisture attached to the jaw (protruded part) of ice mold shall freeze and form frost. If warm water was put into the ice mold, the situation will become worse.</li> </ul>

# TROUBLE DIAGNOSIS

## 4-5. Others

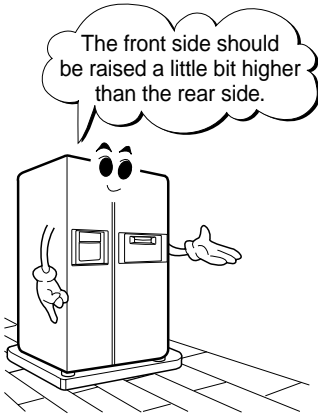
Problems	Checks and Measures
The refrigerator case is hot.	<ul style="list-style-type: none"> <li>■ Explain the principles of radiator.               <ul style="list-style-type: none"> <li>• The radiator pipes are installed in the refrigerator case and partition plate between the refrigerator and the freezer compartment in order to prevent condensation formation. Particularly in summer or after installation of refrigerator, it may feel hot but it is normal. If there is no enough space to dissipate heat, it can be hotter due to lack of heat radiation. Please install a refrigerator in a well-ventilated place and leave a clearance between refrigerator and wall:</li> </ul> </li> </ul>
Small holes in a door liner	<ul style="list-style-type: none"> <li>■ Explain that the hole is for releasing gas.               <ul style="list-style-type: none"> <li>• A small hole in the door liner is for releasing gas during insulation materials lining work. With a releasing hole, forming can be easily done .</li> </ul> </li> </ul>
Electric bills are too much.	<ul style="list-style-type: none"> <li>■ Check the use conditions.               <ul style="list-style-type: none"> <li>• Too frequent door opening and hot food storing cause the compressor to operate continuously and hence increase the electric consumption and bills.</li> </ul> </li> </ul>
Condensation on the inside wall of the refrigerator compartment and the cover of properly vegetable drawer.	<ul style="list-style-type: none"> <li>■ Explain how to store foods               <ul style="list-style-type: none"> <li>• Condensation forms when refrigerator is installed at damp area, door is frequently opened, and wet foods are not stored in the air tight container or wrapped. Be sure to store wet foods in the air tight container or in the wrap.</li> </ul> </li> </ul>
When is the power connected?	<ul style="list-style-type: none"> <li>■ When should the power be connected ?               <ul style="list-style-type: none"> <li>• You can connect the power right after the installation. But if the refrigerator was laid flat during transportation for a long period of time and the refrigerant and compressor oils are mixed up, then this will affect badly the performance of a refrigerator. Be sure to connect the power 2~3 hours after refrigerator is installed.</li> </ul> </li> </ul>
Door does not open properly. <div style="text-align: center; margin-top: 20px;">  </div>	<ul style="list-style-type: none"> <li>■ Refrigerator compartment door does not open properly.               <ul style="list-style-type: none"> <li>• When the door is open, warm open air comes into the compartment and is mixed up with cool air. This mixed air shall be compressed and increase the internal pressure when door is closed. This causes the door stucked closely to the refrigerator in a moment. (If the refrigerator is used for a long time, it will then open smoothly.)</li> </ul> </li> <li>■ When the refrigerator compartment door is open and close, the freezer compartment door moves up and down.               <ul style="list-style-type: none"> <li>• When the refrigerator compartment door is open and close, fresh air comes into the freezer compartment and moves up and down the freezer compartment door.</li> </ul> </li> <li>■ Door opens too easily.               <ul style="list-style-type: none"> <li>• There is a magnet in the gasket rubber so that it is ok. if door is securely closed without a gap. It can be open easily if the foods in the refrigerator or freezer compartments hold the door open.</li> </ul> </li> <li>■ A door does not close properly.               <ul style="list-style-type: none"> <li>• If the rear side of the refrigerator is raised higher than front side, door shall not be easily closed. Adjust the level of refrigerator with levelling screws.</li> </ul> </li> </ul>

# HOW TO DISASSEMBLE AND ASSEMBLE

## 1. DOOR

### 1) Remove lower cover and then disconnect water supply tube in the lower part of freezer door.

- Pull a water supply tube ② forward while pressing ① part to disconnect water supply tube as shown below.

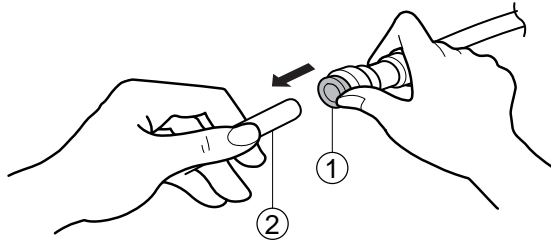

### 2) Remove a freezer door.

- (1) Loosen hinge cover screw of freezer door and remove cover.  
Disconnect all connecting lines except earthing cord.

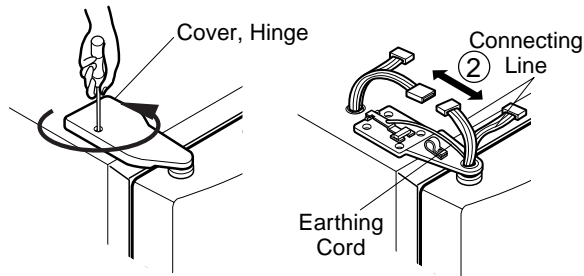

- (2) Turn hinge lever in arrow (A) direction until it is loosened and take it out in arrow B direction.

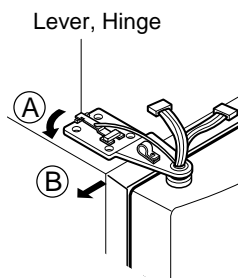

**Note :** • When disconnecting refrigerator door, turn hinge lever counterclockwise.

- If hinge lever or bracket hinge pin is deformed during assembling freezer and refrigerator doors, fix two screws (Tap Tite Screw, M6: Hinge, L fixing screw) in the hole of upper hinge.

- (3) Disconnect upper hinge ① from a hinge supporter ② by grasping the front part of upper hinge and lifting up (Hinge Assy, U) in arrow direction (A) and pull forward in arrow (B) direction. Be careful as the door may be fallen down.

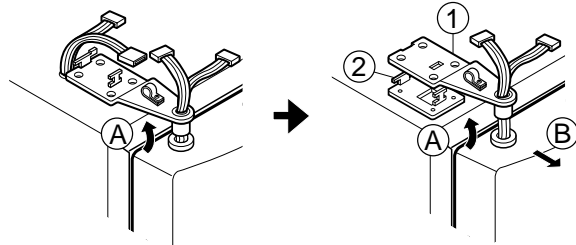

- (4) Lift up the freezer door ① in arrow direction and disconnect the door from the lower hinge ②. Don't pull a door forward.

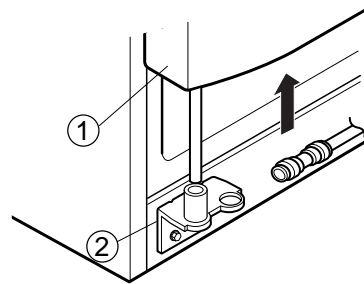

**Note :** • Lift up a freezer door until a water supply tube is fully taken out.

- (5) Assembly is the reverse order of disassembly

# HOW TO DISASSEMBLE AND ASSEMBLE

## 2. HANDLE

- 1) Put blade screwdriver into a groove on the side of a Deco handle and lift up a little bit in arrow ① direction and push up with hand in arrow ② direction and disconnect.

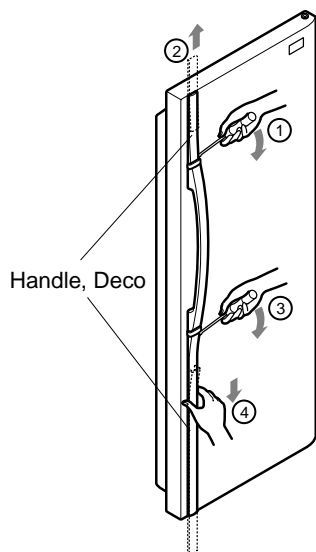

- 2) Put blade screwdriver into a groove on the side of a DECO handle and lift up in arrow direction ③ and push down with hand in arrow direction ④ and disconnect.
- 3) Push up a piece handle ③ in arrow direction with hand and disconnect.
- 4) Turn screw in arrow direction with a cross driver and disconnect.

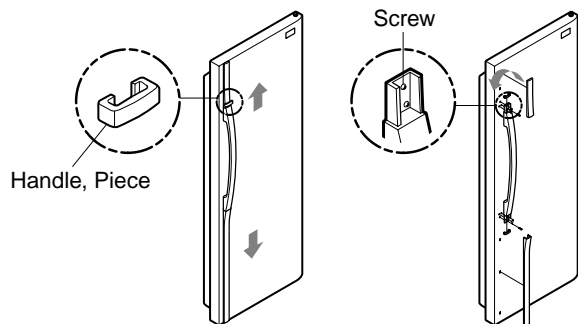

## 3. SHROUD, GRILLE FAN

- 1) Loosen two screws after disconnecting a cap screw of a grille fan(U) with a blade screwdriver.
- 2) Disassembly of a grille fan(U) : Pull forward after opening hook at → part with a blade screwdriver.
- 3) Disconnect housing A of a grille fan (L) from the main body.

- 4) Disassembly of a grille fan (L) : Hold upper part of a grille fan(L) and pull forward carefully.
- 5) Loosen two screws.
- 6) Disassembly of shroud. F(U) : Disconnect housing of B after removing two rail guides with a blade screwdriver.
- 7) Disassembly of shroud. F(U) : Hold upper part and pull forward.
- 8) Check foam PU sticking conditions around a shroud, F(U) and F(L) during assembling. If damaged, torn or badly stuck, assemble with a new one after sealing well.

## 4. ICEMAKER ASSY

### 1. Dispenser Model

- 1) How to disassemble:
  - (1) Remove ice bank from the freezer compartment.
  - (2) Loosen two screws on the upper part of icemaker bracket.
  - (3) Disconnect icemaker bracket so that it can slide forward.
  - (4) Disconnect icemaker housing and sensor housing.
  - (5) Disconnect icemaker horizontally by pressing bracket hook part. ( Don't disassemble further. The set value may be changed.)
- 2) How to assemble : The assembly is the reverse order of the above disassembly.

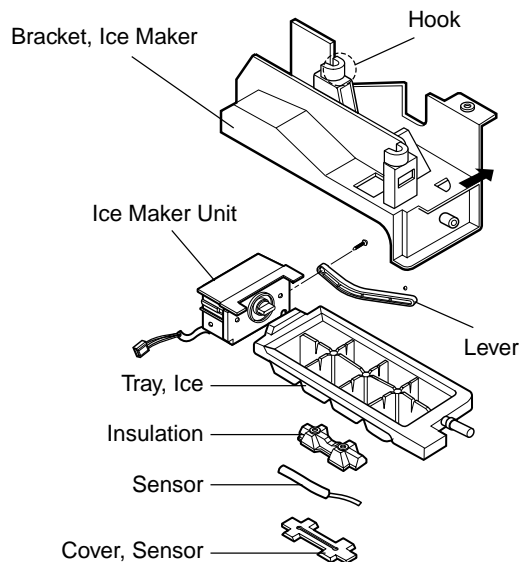

**Note :** When the ice tray is not horizontal after assembly, assembly must be wrong. Check and assemble again.

# HOW TO DISASSEMBLE AND ASSEMBLE

## 5. DISPENSER

- 1) Disconnect button assembly by pulling down until it stops and then pulling forward.

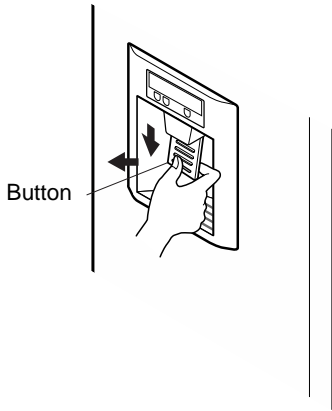

- 2) Remove display frame Assy by making a gap between a display frame Assy. and funnel Assy. with a blade screwdriver and pulling it forward. The cover dispenser is fixed with a hook.

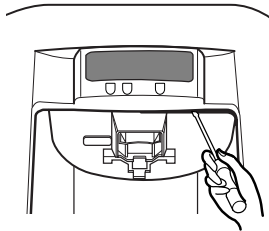

- 3) Display Assy can be disconnected by pressing the upper part of a cover dispenser and pushing a display Assy. after disconnecting display frame Assy. housing.

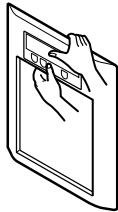

- 4) Loosen four screws with a phillips screwdriver and pull a funnel Assy to disconnect.

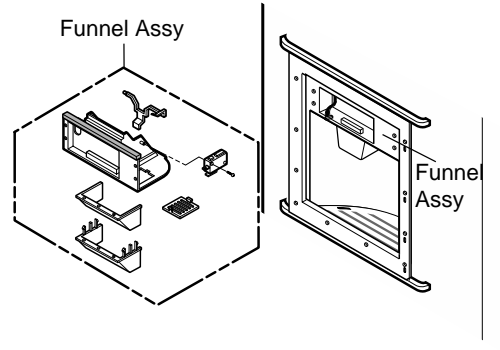

- 5) Duct cap Assy is disconnected if hold lever connecting screw is loosened with a phillips screwdriver.

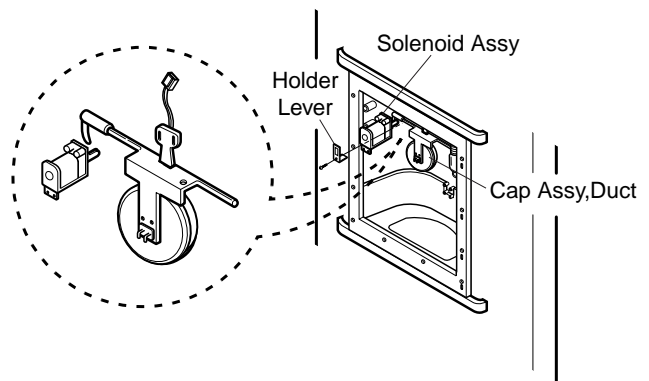

- 6) For assembling a duct cap Assy., insert one end of a spring into the right hole of dispenser lever, and insert the other end into the right hole in upper part of dispenser. And then assemble a holder lever after fixing a holder at a solenoid Assy working part.

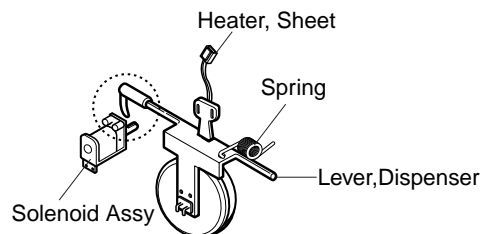

# HOW TO DISASSEMBLE AND ASSEMBLE

## 7) Dispenser Related Parts

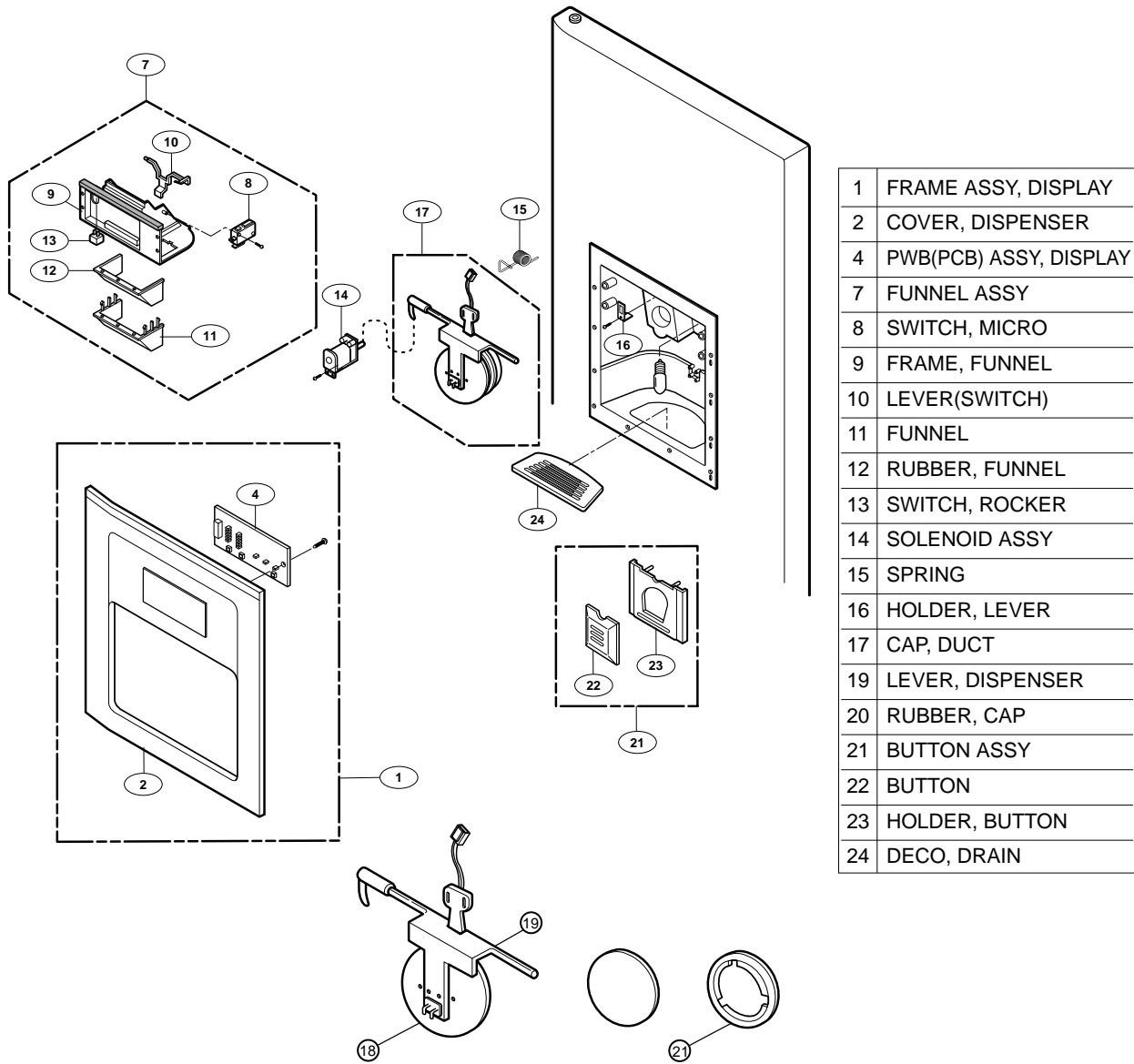

< 17 Cap Assy, Duct Detailed Drawings >

# HOW TO DISASSEMBLE AND ASSEMBLE

## 6. WATER TANK AND WATER LINE

► The water tank at back and lower part of a refrigerator is fixed by one screw and has a capacity containing 7 glasses (180cc per glass) of cold water. It will take time to make more cold water in the tank.

\* The first portion of dispensed water is not cold even though the refrigerator is working. In this case, dispense ice first in the cup and then water to make a cold water.

## 7. HOME BAR

### 7-1. Home Bar related parts

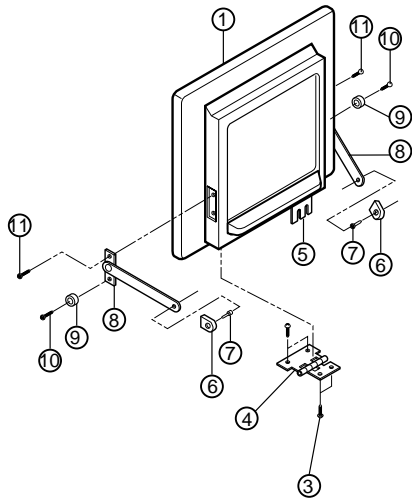

1 DOOR ASSY, H/BAR	7 SCREW TAP TITE(ARM)
2 SEREW, TAP TITE(HINGE-H/B)	8 ARM ASSY
3 SCREW MACHINE(HINGE-H/B)	9 STOPPER
4 HINGE ASSY H/BAR	10 SCREW, MACHINE(STOP ARM-H/B)
5 HINGE ASSY H/BAR	11 SCREW MACHINE(HINGE-H/B)
6 CAP, ARM	

### 7-2. Home Bar parts disassembly and assembly

- 1) Disconnect H/Bar Door Assy ①.
- 2) Loosen two screws ⑦ attached on the refrigerator compartment door with a phillips screwdriver. And loosen 4 screws ② and two screws ③. Pull H/Bar door Assy ①. forward to disassemble.
- 3) Loosen two screws ⑩, ⑨ fixed on H/Bar door Assy. and two screws ⑪ with a cross driver to disassemble arm Assy.
- 4) Assemble parts by performing the disassembly in reverse order.

Note : • Assemble carefully parts ⑦, ⑩, ⑪ until they are fixed firmly when assembling them.

• Adjust exterior gap by adjusting parts ②, ⑦ and when assembling.

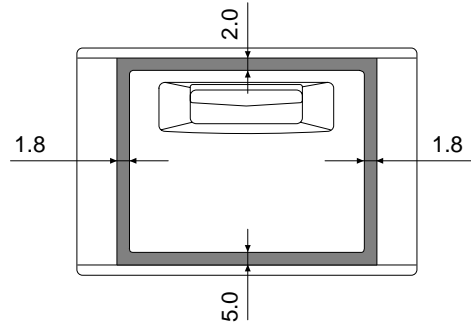

# EXPLODED VIEW

FREEZER DOOR PART: GR-P247, GR-P207, GR-L247, GR-L207

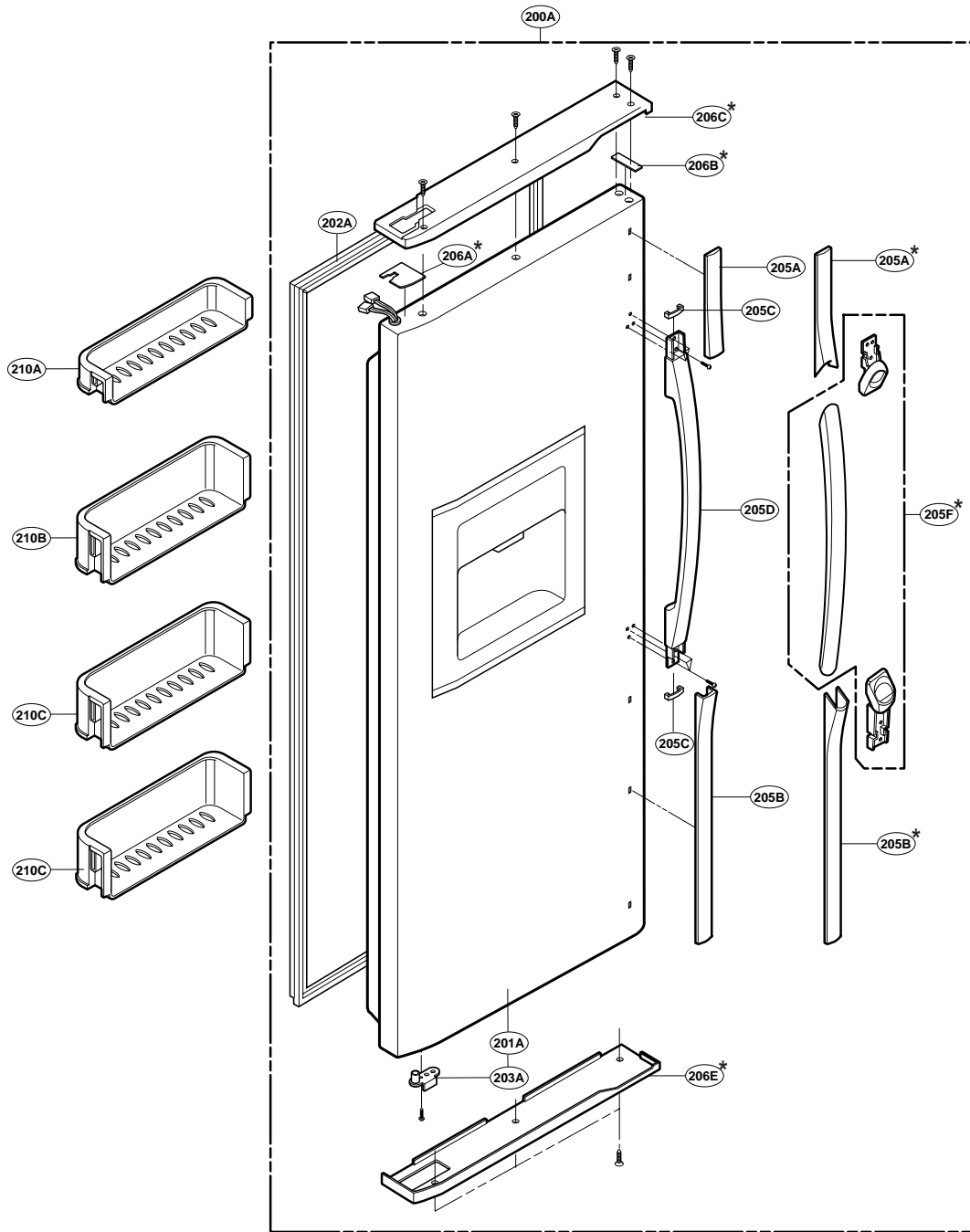



# EXPLODED VIEW

FREEZER DOOR PART: GR-C247, GR-C207, GR-B247, GR-B207, GR-B197

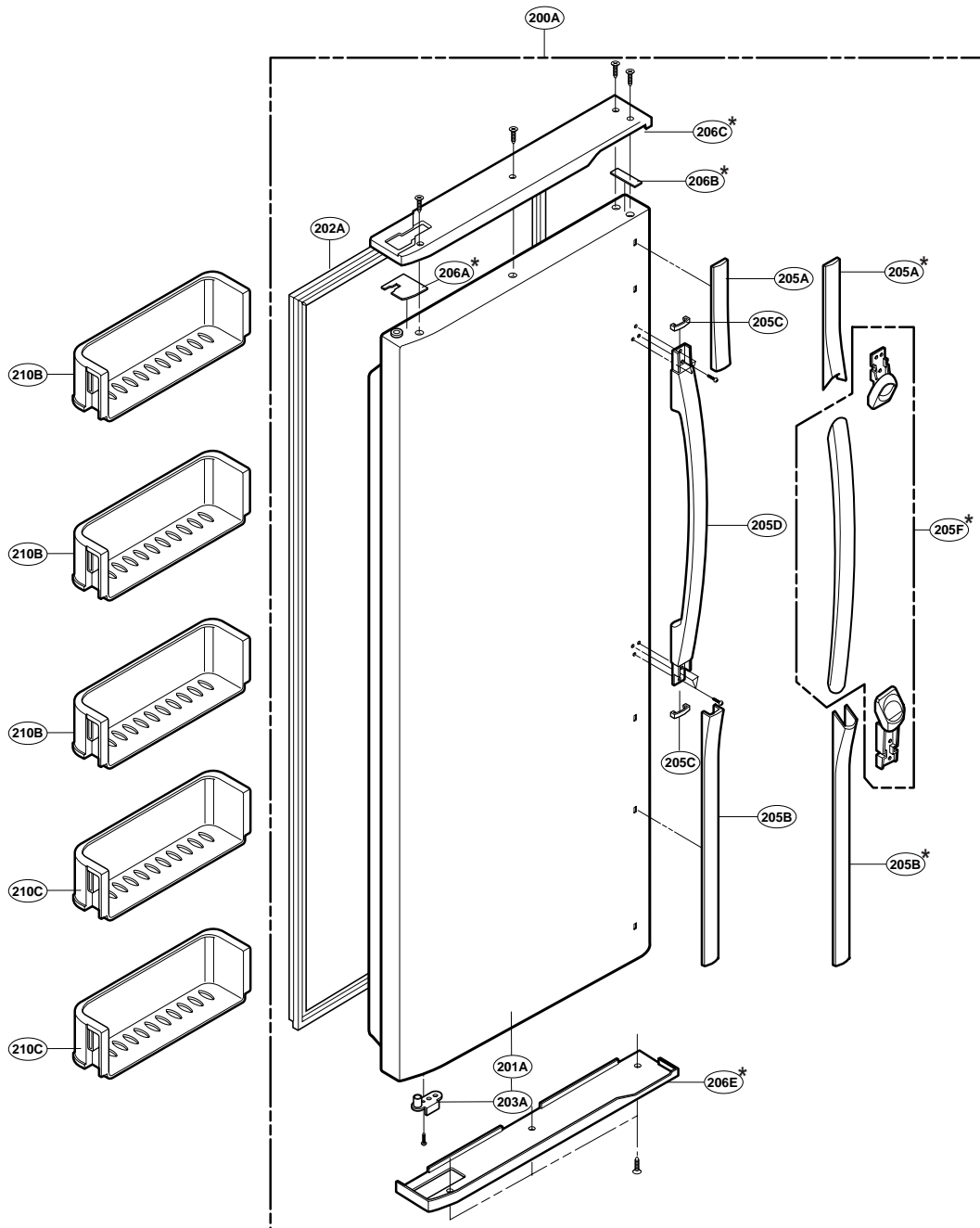

# EXPLODED VIEW

Ref No. : GR-P247, GR-P207, GR-C247, GR-C207

REFRIGERATOR DOOR PART

\* : Optional part

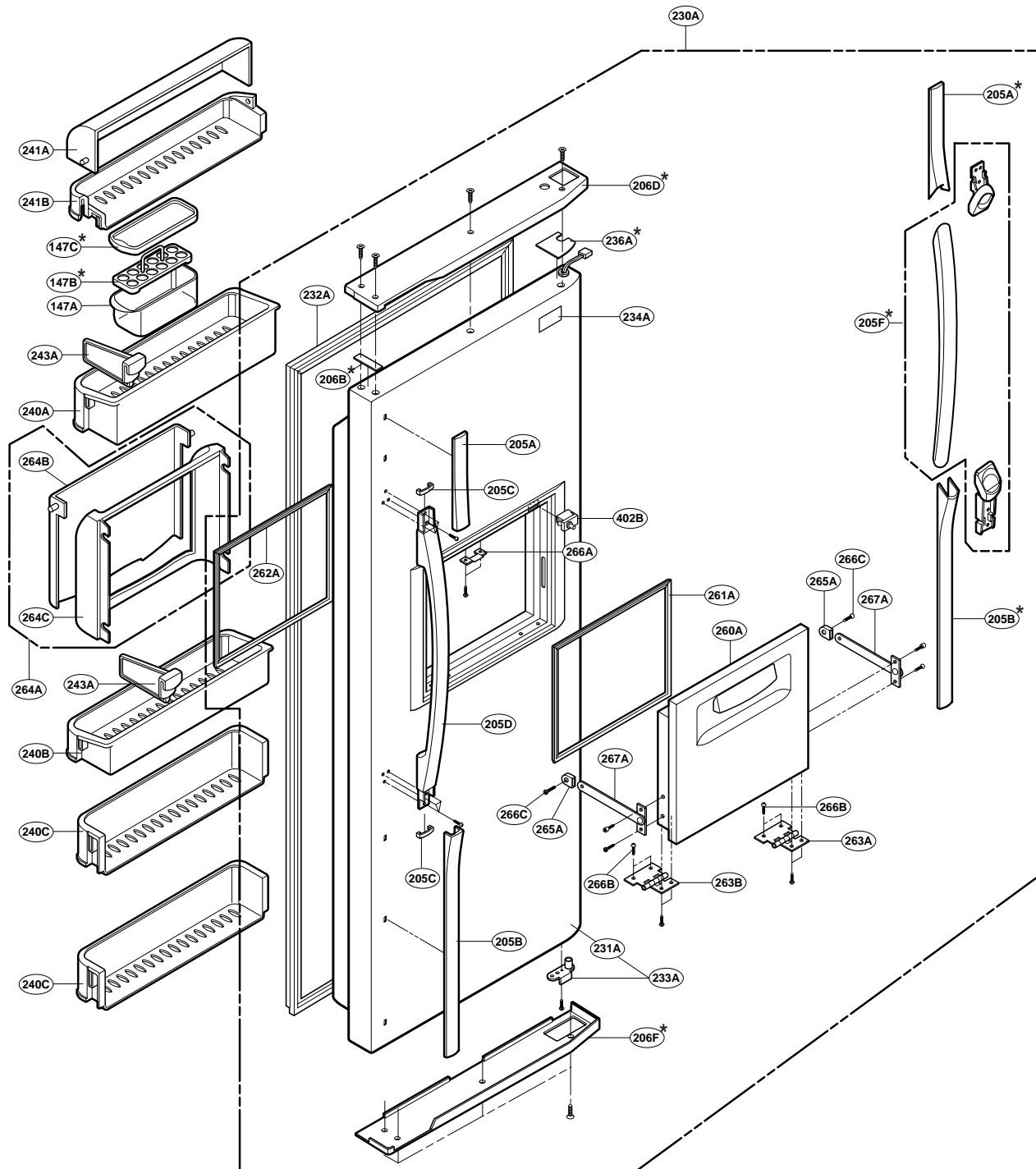

# EXPLODED VIEW

Ref No. : GR-L247, GR-L207, GR-B247, GR-B207, GR-B197

REFRIGERATOR DOOR PART

\* : Optional part

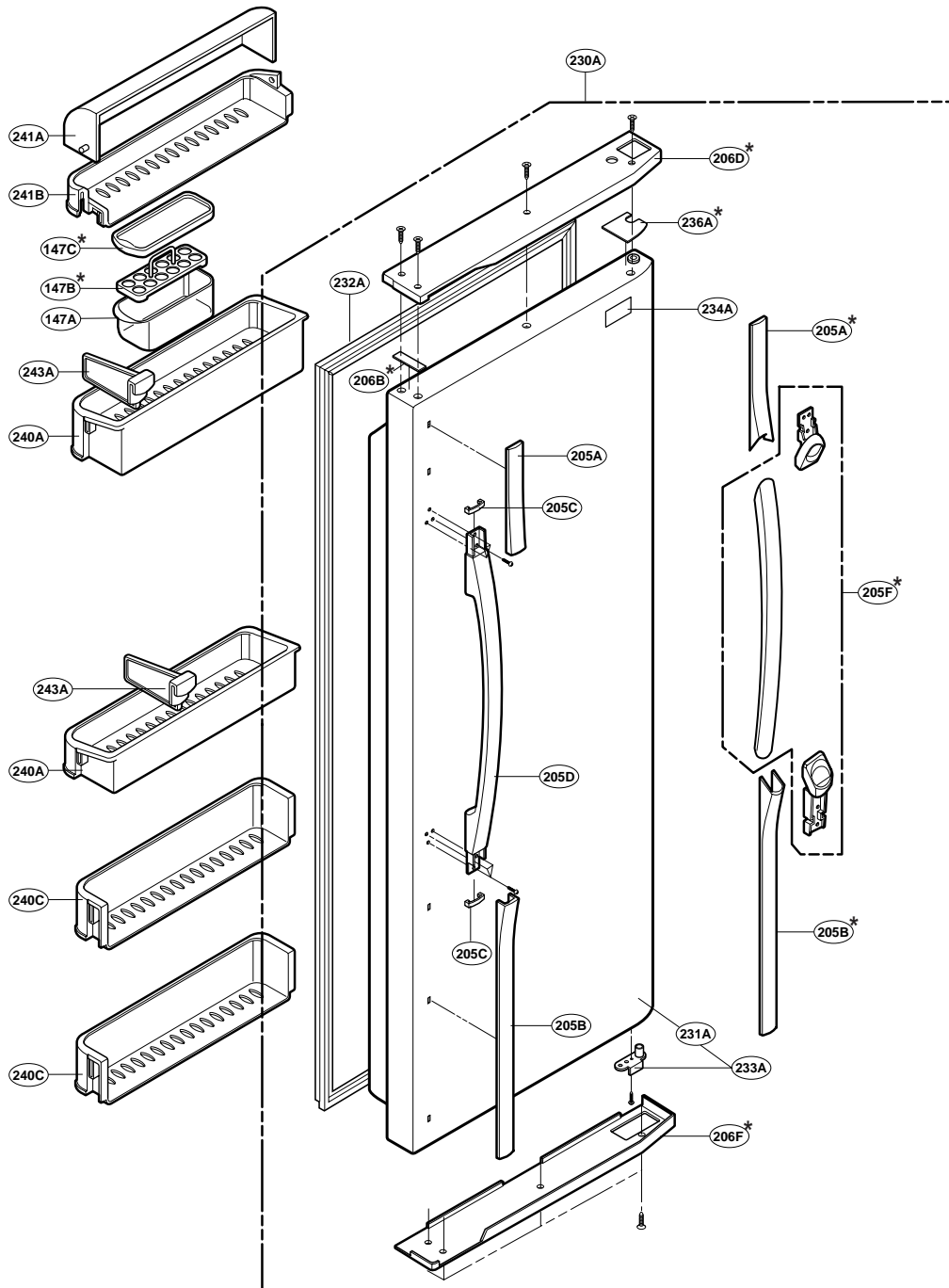

# EXPLODED VIEW

## FREEZER COMPARTMENT

\* : Optional part

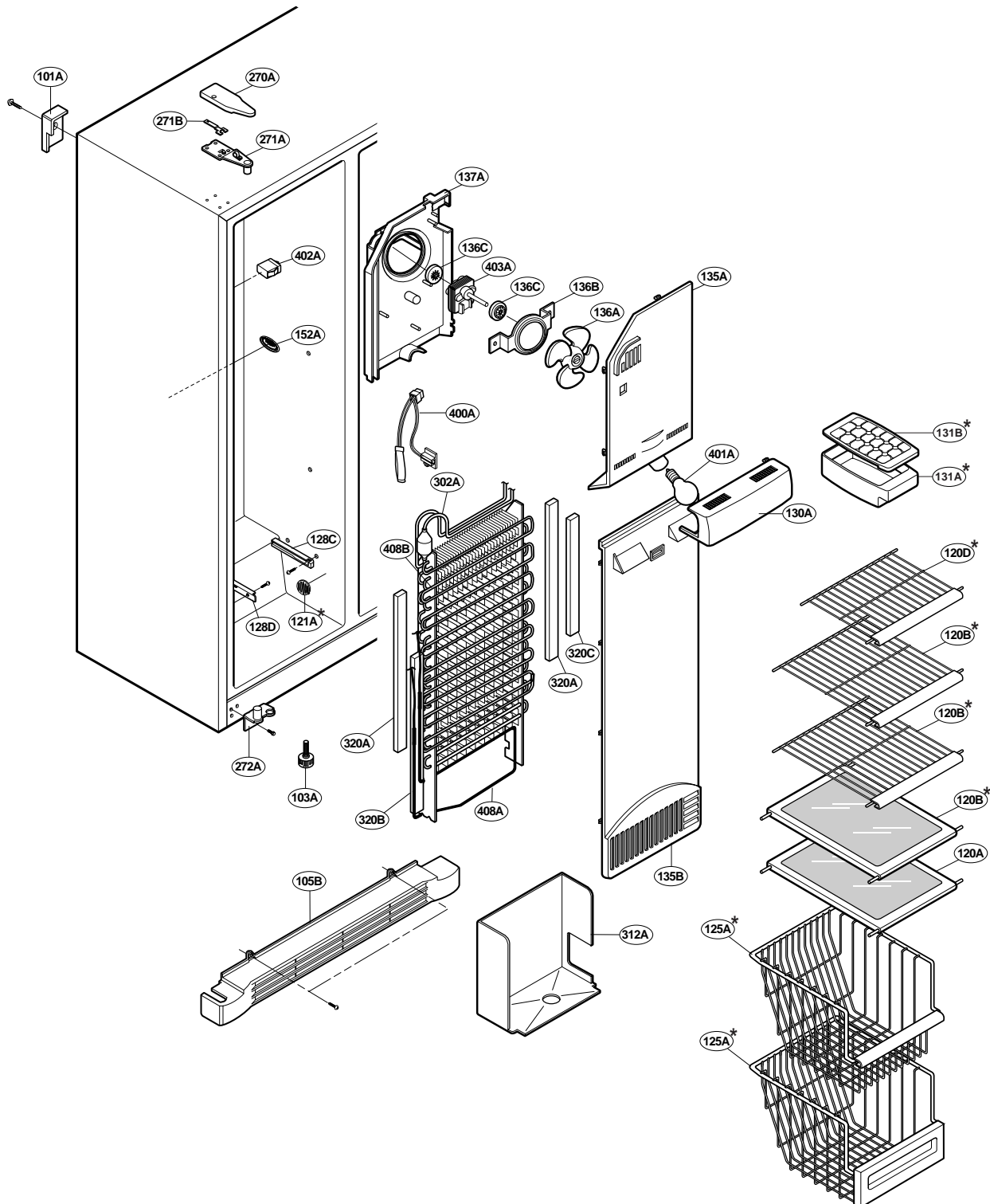

# EXPLODED VIEW

## REFRIGERATOR COMPARTMENT

\* : Optional part

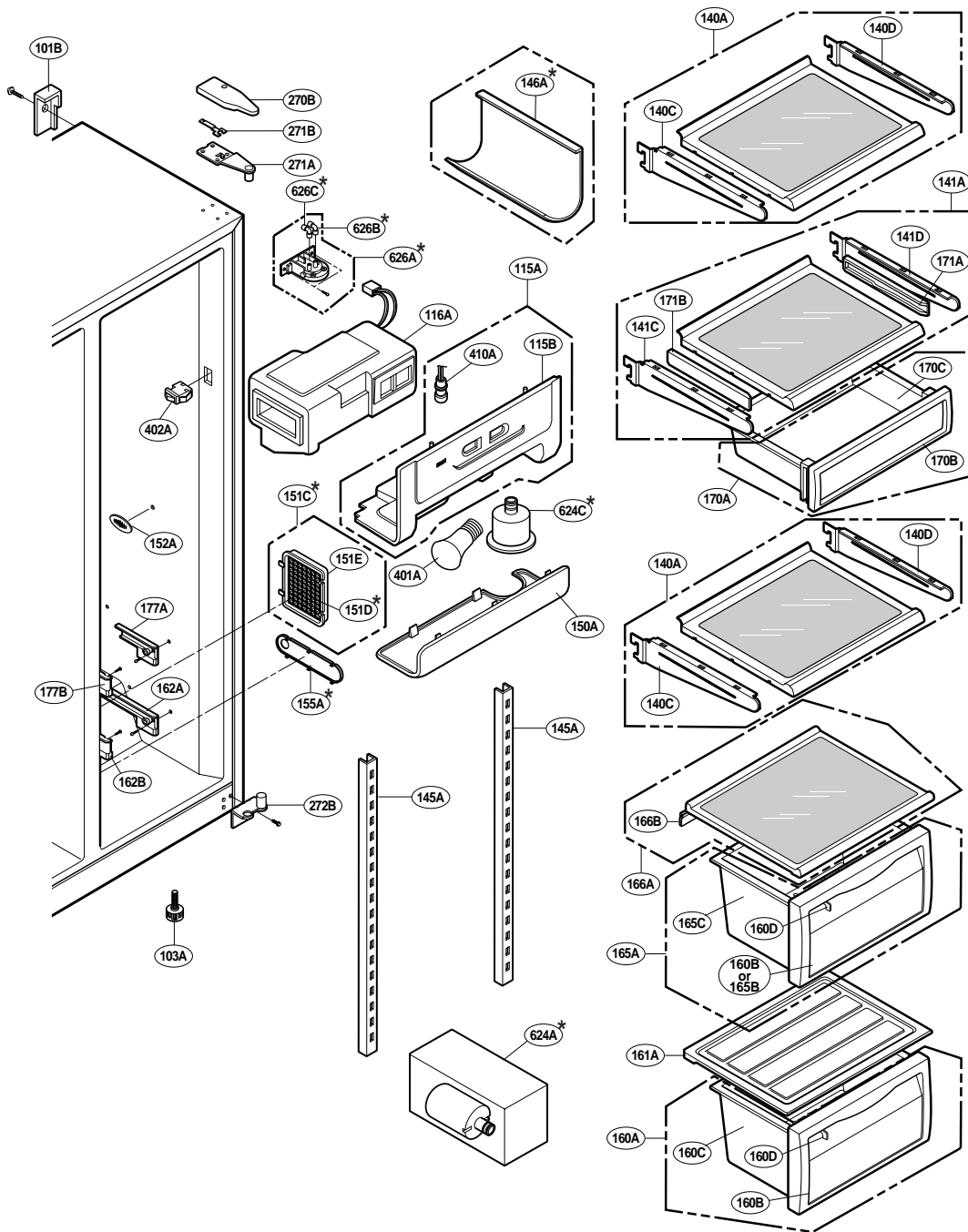

# EXPLODED VIEW

## ICE & WATER PART

\* : Optional part

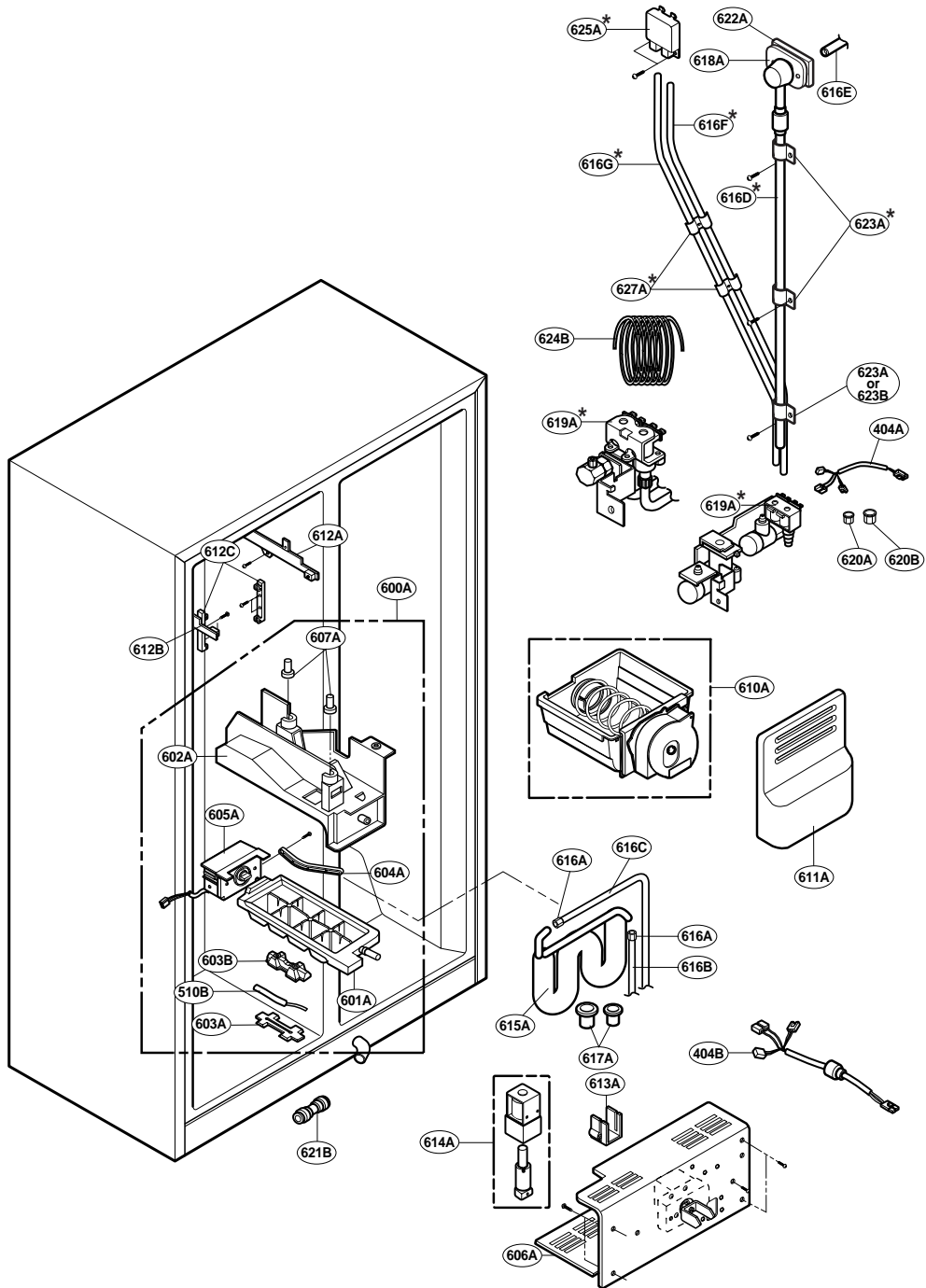

# EXPLODED VIEW

## MACHINE COMPARTMENT

\* : Optional part

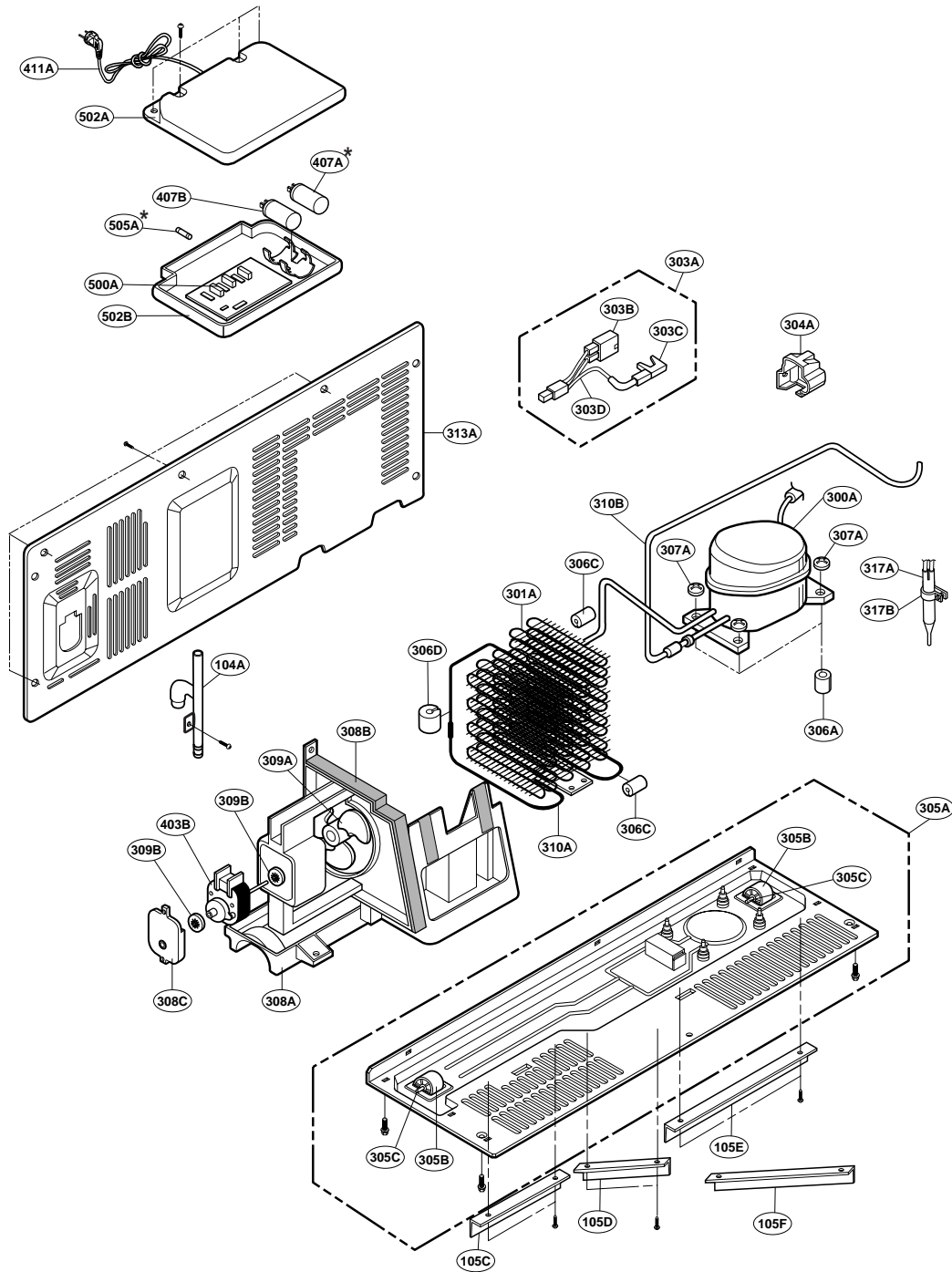

# EXPLODED VIEW

## DISPENSER PART

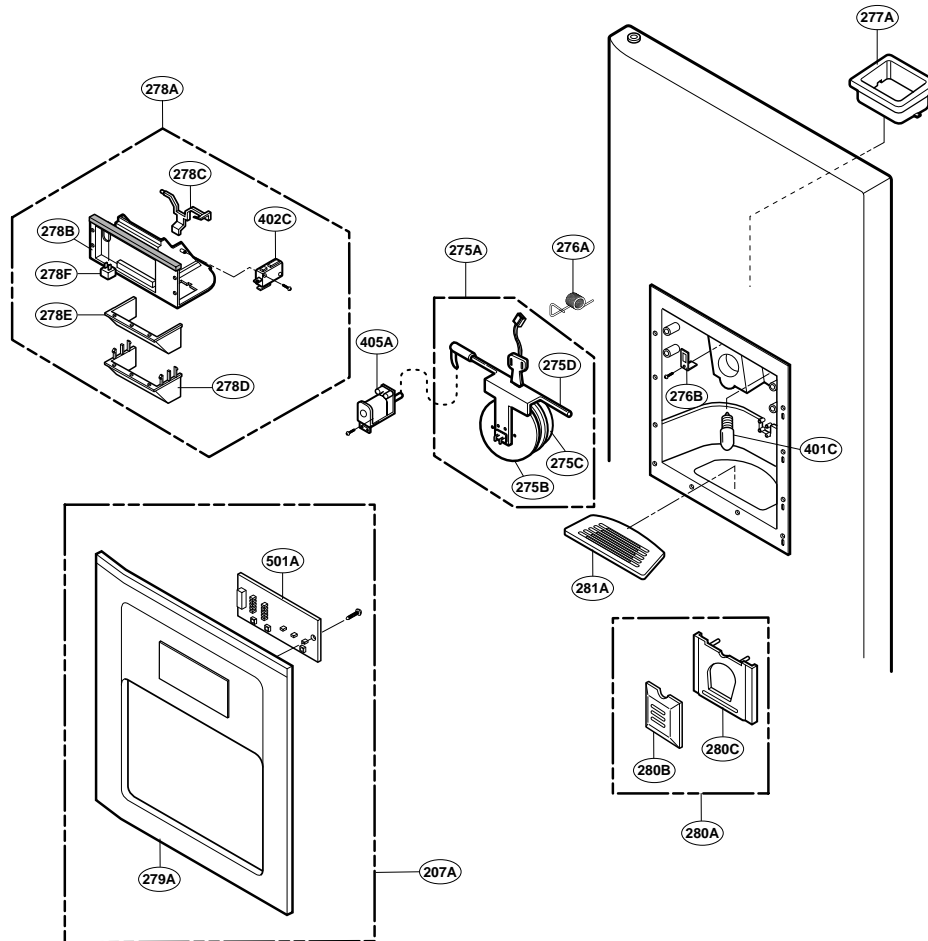





P/No. 3828JD8545H

OCT., 2003 Printed in Korea

