

Service Manual

M-CR603 /N1SG/N1B△/U1B△

CD Receiver

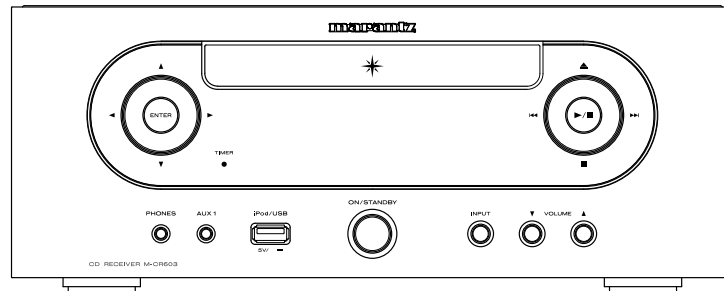

• For purposes of improvement, specifications and design are subject to change without notice.

• Please use this service manual with referring to the operating instructions without fail.

• Some illustrations using in this service manual are slightly different from the actual set.

marantz®

M-CR603

Ver. 8

Please refer to the
MODIFICATION NOTICE.

MARANTZ DESIGN AND SERVICE

Using superior design and selected high grade components, **MARANTZ** company has created the ultimate in stereo sound. Only original **MARANTZ** parts can insure that your **MARANTZ** product will continue to perform to the specifications for which it is famous.

Parts for your **MARANTZ** equipment are generally available to our National Marantz Subsidiary or Agent.

ORDERING PARTS :

Parts can be ordered either by mail or by Fax.. In both cases, the correct part number has to be specified.

The following information must be supplied to eliminate delays in processing your order :

1. Complete address
2. Complete part numbers and quantities required
3. Description of parts
4. Model number for which part is required
5. Way of shipment
6. Signature : any order form or Fax. must be signed, otherwise such part order will be considered as null and void.

USA

MARANTZ AMERICA, INC
100 CORPORATE DRIVE
MAHWAH, NEW JERSEY 07430
USA

EUROPE / TRADING

D&M EUROPE B. V.
P. O. BOX 8744, BUILDING SILVERPOINT
BEEEMDSTRAAT 11, 5653 MA EINDHOVEN
THE NETHERLANDS
PHONE : +31 - 40 - 2507844
FAX : +31 - 40 - 2507860

CANADA

D&M Canada Inc.
5-505 APPLE CREEK BLVD.
MARKHAM, ONTARIO L3R 5B1
CANADA
PHONE : 905 - 415 - 9292
FAX : 905 - 475 - 4159

JAPAN

D&M Holdings Inc.
D&M BUILDING, 2-1 NISSHIN-CHO,
KAWASAKI-KU, KAWASAKI-SHI,
KANAGAWA, 210-8569 JAPAN

株式会社 ディーアンドエムホールディングス

本 社 〒210-8569
神奈川県川崎市川崎区日進町2-1 D&Mビル

KOREA

D&M SALES AND MARKETING KOREA LTD.
2F, YEON BLDG.,
88-5, BANPO-DONG, SEOCHO-GU,
SEOUL KOREA
PHONE : +82 - 2 - 715 - 9041
FAX : +82 - 2 - 715 - 9040

CHINA

D&M SALES AND MARKETING SHANGHAI LTD.
ROOM.808 SHANGHAI AIRPORT CITY TERMINAL
NO.1600 NANJING (WEST) ROAD, SHANGHAI,
CHINA. 200040
TEL : 021 - 6248 - 5151
FAX : 021 - 6248 - 4434

NOTE ON SAFETY :

Symbol ⚠ Fire or electrical shock hazard. Only original parts should be used to replaced any part marked with symbol ⚠.

Any other component substitution (other than original type), may increase risk of fire or electrical shock hazard.

安全上の注意 :

⚠がついている部品は、安全上重要な部品です。必ず指定されている部品番号のものを使用して下さい。

SHOCK, FIRE HAZARD SERVICE TEST :

CAUTION : After servicing this appliance and prior to returning to customer, measure the resistance between either primary AC cord connector pins (with unit NOT connected to AC mains and its Power switch ON), and the face or Front Panel of product and controls and chassis bottom.

Any resistance measurement less than 1 Megohms should cause unit to be repaired or corrected before AC power is applied, and verified before it is return to the user/customer.

Ref. UL Standard No. 60065.

In case of difficulties, do not hesitate to contact the Technical Department at above mentioned address.

SAFETY PRECAUTIONS

The following check should be performed for the continued protection of the customer and service technician.

LEAKAGE CURRENT CHECK

Before returning the unit to the customer, make sure you make either (1) a leakage current check or (2) a line to chassis resistance check. If the leakage current exceeds 0.5 milliamps, or if the resistance from chassis to either side of the power cord is less than 460 kohms, the unit is defective.

Be sure to test for leakage current with the AC plug in both polarities, in addition, in each power ON, OFF and STANDBY mode, if applicable.

CAUTION Please heed the points listed below during servicing and inspection.

⊙ Heed the cautions!

Spots requiring particular attention when servicing, such as the cabinet, parts, chassis, etc., have cautions indicated on labels. Be sure to heed these cautions and the cautions indicated in the handling instructions.

⊙ Caution concerning electric shock!

- (1) An AC voltage is impressed on this set, so touching internal metal parts when the set is energized could cause electric shock. Take care to avoid electric shock, by for example using an isolating transformer and gloves when servicing while the set is energized, unplugging the power cord when replacing parts, etc.
- (2) There are high voltage parts inside. Handle with extra care when the set is energized.

⊙ Caution concerning disassembly and assembly!

Through great care is taken when manufacturing parts from sheet metal, there may in some rare cases be burrs on the edges of parts which could cause injury if fingers are moved across them. Use gloves to protect your hands.

⊙ Only use designated parts!

The set's parts have specific safety properties (fire resistance, voltage resistance, etc.). For replacement parts, be sure to use parts which have the same properties. In particular, for the important safety parts that are marked \triangle on wiring diagrams and parts lists, be sure to use the designated parts.

⊙ Be sure to mount parts and arrange the wires as they were originally!

For safety reasons, some parts use tape, tubes or other insulating materials, and some parts are mounted away from the surface of printed circuit boards. Care is also taken with the positions of the wires and clamps are used to keep wires away from heating and high voltage parts, so be sure to set everything back as it was originally.

⊙ Inspect for safety after servicing!

Check that all screws, parts and wires removed or disconnected for servicing have been put back in their original positions, inspect that no parts around the area that has been serviced have been negatively affected, conduct an insulation check on the external metal connectors and between the blades of the power plug, and otherwise check that safety is ensured.

(Insulation check procedure)

Unplug the power cord from the power outlet, disconnect the antenna, plugs, etc., and turn the power switch on. Using a 500V insulation resistance tester, check that the inplug and the externally exposed metal parts (antenna terminal, headphones terminal, input terminal, etc.) is 1M Ω or greater. If it is less, the set must be inspected and repaired.

CAUTION Concerning important safety parts

Many of the electric and structural parts used in the set have special safety properties. In most cases these properties are difficult to distinguish by sight, and using replacement parts with higher ratings (rated power and withstand voltage) does not necessarily guarantee that safety performance will be preserved. Parts with safety properties are indicated as shown below on the wiring diagrams and parts lists in this service manual. Be sure to replace them with parts with the designated part number.

- (1) Schematic diagrams Indicated by the \triangle mark.
- (2) Parts lists Indicated by the \triangle mark.

Using parts other than the designated parts could result in electric shock, fires or other dangerous situations.

NOTE FOR SCHEMATIC DIAGRAM

WARNING:

Parts marked with this symbol \triangle have critical characteristics. Use ONLY replacement parts recommended by the manufacturer.

CAUTION:

Before returning the unit to the customer, make sure you make either (1) a leakage current check or (2) a line to chassis resistance check. If the leakage current exceeds 0.5 milliamps, or if the resistance from chassis to either side of the power cord is less than 460 kohms, the unit is defective.

WARNING:

DO NOT return the unit to the customer until the problem is located and corrected.

NOTICE:

ALL RESISTANCE VALUES IN OHM. k=1,000 OHM / M=1,000,000 OHM

ALL CAPACITANCE VALUES IN MICRO FARAD. P=MICRO-MICRO FARAD EACH VOLTAGE AND CURRENT ARE MEASURED AT NO SIGNAL INPUT CONDITION. CIRCUIT AND PARTS ARE SUBJECT TO CHANGE WITHOUT PRIOR NOTICE.

NOTE FOR PARTS LIST

PARTS INFORMATION

RESISTORS

1) 00MGD05 xxx 140, Carbon film fixed resistor, $\pm 5\%$ 1/4W

2) 00MGD05 xxx 160, Carbon film fixed resistor, $\pm 5\%$ 1/6W

① Resistance value

Examples ;

① Resistance value

0.1 Ω001	10 Ω100	1k Ω102	100k Ω104
0.5 Ω005	18 Ω180	2.7k Ω272	680k Ω684
1 Ω010	100 Ω101	10k Ω103	1M Ω105
6.8 Ω068	390 Ω391	22k Ω223	4.7M Ω475

Note : Please distinguish 1/4W from 1/6W by the shape of parts used actually.

CAPACITORS

CERAMIC CAP.

3) 00MDD1 xxx 370,

② Ceramic capacitor
Disc type
Temp.coeff.P350 ~ N1000, 50V
Capacity value
Tolerance

Examples ;

② Tolerance (Capacity deviation)
 $\pm 0.25\text{pF}$ 0
 $\pm 0.5\text{pF}$ 1
 $\pm 5\%$ 5

* Tolerance of COMMON PARTS handled here are as follows :

0.5pF ~ 5pF $\pm 0.25\text{pF}$
6pF ~ 10pF $\pm 0.5\text{pF}$
12pF ~ 560pF $\pm 5\%$

③ Capacity value

0.5pF005	3pF030	100pF101
1pF010	10pF100	220pF221
1.5pF015	47pF470	560pF561

CERAMIC CAP.

4) 00MDK16 xxx 300,

④ High dielectric constant ceramic capacitor
Disc type
Temp.chara. 2B4, 50V
Capacity value

Examples ;

④ Capacity value

100pF101	1000pF102	10000pF103
470pF471	2200pF222	

ELECTROLY CAP. (Z)

5) 00MEA xxx 10,

⑤ Electrolytic capacitor
One-way lead type, Tolerance $\pm 20\%$
Working voltage
Capacity value

Examples ;

⑤ Capacity value

0.1 μF104	4.7 μF475	100 μF ... 107
0.33 μF334	10 μF106	330 μF ... 337
1 μF105	22 μF226	1100 μF ... 118
		2200 μF ... 228

⑥ Working voltage

6.3V.....006	25V.....025
10V.....010	35V.....035
16V.....016	50V.....050

FILM CAP. (Z)

6) 00MDF15 xxx 350

⑦ Plastic film capacitor
One-way type, Mylar $\pm 5\%$ 50V
00MDF15 xxx 310
Plastic film capacitor
One-way type, Mylar $\pm 10\%$ 50V
Capacity value

Examples ;

⑦ Capacity value

0.001 μF (1000pF)102	0.1 μF 104
0.0018 μF182	0.56 μF 564
0.01 μF103	1 μF 105
0.015 μF153	

NOTE ON SAFETY FOR FUSIBLE RESISTOR :

The suppliers and their type numbers of fusible resistors are as follows;

1. KOA Corporation

Part No. (MJI)	Type No. (KOA)	Description
00MNH05 xxx 140	RF25S xxx Ω J	($\pm 5\%$ 1/4W)
00MNH05 xxx 120	RF50S xxx Ω J	($\pm 5\%$ 1/2W)
00MNH85 xxx 110	RF73B2A xxx Ω J	($\pm 5\%$ 1/10W)
00MNH95 xxx 140	RF73B2E xxx Ω J	($\pm 5\%$ 1/4W)

* Resistance value Resistance value (0.1 - 10k Ω)

2. Matsushita Electronic Components Co., Ltd

Part No. (MJI)	Type No. (MEC)	Description
00MNF05 xxx 140	ERD-2FCJ xxx	($\pm 5\%$ 1/4W)
00MRF05 xxx 140		
00MNF02 xxx 140	ERD-2FCG xxx	($\pm 2\%$ 1/4W)
00MRF02 xxx 140		

* Resistance value * Resistance value

Examples ;

* Resistance value

0.1 Ω001	10 Ω100	1k Ω102	100k Ω104
0.5 Ω005	18 Ω180	2.7k Ω272	680k Ω684
1 Ω010	100 Ω101	10k Ω103	1M Ω105
6.8 Ω068	390 Ω391	22k Ω223	4.7M Ω475

ABBREVIATION AND MARKS

ANT. : ANTENNA	BATT. : BATTERY
CAP. : CAPACITOR	CER. : CERAMIC
CONN. : CONNECTING	DIG. : DIGITAL
HP : HEADPHONE	MIC. : MICROPHONE
μ -PRO : MICROPROCESSOR	REC. : RECORDING
RES. : RESISTOR	SPK : SPEAKER
SW : SWITCH	TRANSF. : TRANSFORMER
TRIM. : TRIMMING	TRS. : TRANSISTOR
VAR. : VARIABLE	X'TAL : CRYSTAL

NOTE ON FUSE :

Regarding to all parts of parts code **00MFS20xxx2xx**, replace only with Wickmann-Werke GmbH, Type 372 non glass type fuse.

NOTE ON SAFETY :

Symbol \triangle Fire or electrical shock hazard. Only original parts should be used to replaced any part marked with symbol \triangle . Any other component substitution (other than original type), may increase risk of fire or electrical shock hazard.

安全上の注意 :

\triangle がついている部品は、安全上重要な部品です。必ず指定されている部品番号の部品を使用して下さい。

WARNING AND LASER SAFETY INSTRUCTIONS

(GB) WARNING

All ICs and many other semi-conductors are susceptible to electrostatic discharges (ESD). Careless handling during repair can reduce life drastically.

When repairing, make sure that you are connected with the same potential as the mass of the set via a wrist wrap with resistance.

Keep components and tools also at this potential.

ESD



(NL) WAARSCHUWING

Alle IC's en vele andere halfgeleiders zijn gevoelig voor elektrostatische ontladingen (ESD).

Onzorgvuldig behandelen tijdens reparatie kan de levensduur drastisch doen verminderen.

Zorg ervoor dat u tijdens reparatie via een polsband met weerstand verbonden bent met hetzelfde potentiaal als de massa van het apparaat.

Houd componenten en hulpmiddelen ook op hetzelfde potentiaal.

(F) ATTENTION

Tous les IC et beaucoup d'autres semi-conducteurs sont sensibles aux décharges statiques (ESD).

Leur longévité pourrait être considérablement écourtée par le fait qu'aucune précaution n'est prise à leur manipulation.

Lors de réparations, s'assurer de bien être relié au même potentiel que la masse de l'appareil et enfiler le braceleterti d'une résistance de sécurité.

Veiller à ce que les composants ainsi que les outils que l'on utilise soient également à ce potentiel.

(D) WARNUNG

Alle IC und viele andere Halbleiter sind empfindlich gegen elektrostatische Entladungen (ESD).

Unvorsichtige Behandlung bei der Reparatur kann die Lebensdauer drastisch vermindern. Sorgen sie dafür, das Sie im Reparaturfall über ein Pulsarmband mit Widerstand mit dem Massepotential des Gerätes verbunden sind.

Halten Sie Bauteile und Hilfsmittel ebenfalls auf diesem Potential.

(I) AVVERTIMENTO

Tutti IC e parecchi semi-conduttori sono sensibili alle scariche statiche (ESD).

La loro longevità potrebbe essere fortemente ridatta in caso di non osservazione della più grande cauzione alla loro manipolazione.

Durante le riparazioni occorre quindi essere collegato allo stesso potenziale che quello della massa dell'apparecchio tramite un braccialetto a resistenza.

Assicurarsi che i componenti e anche gli utensili con quali si lavora siano anche a questo potenziale.

(GB)

Safety regulations require that the set be restored to its original condition and that parts which are identical with those specified be used.

(NL)

Veiligheidsbepalingen vereisen, dat het apparaat in zijn oorspronkelijke toestand wordt terug gebracht en dat onderdelen, identiek aan de gespecificeerde worden toegepast.

(D)

Bei jeder Reparatur sind die geltenden Sicherheitsvorschriften zu beachten. Der Originalzustand des Geräts darf nicht verändert werden. Für Reparaturen sind Original-Ersatzteile zu verwenden.

(I)

Le norme di sicurezza esigono che l'apparecchio venga rimesso nelle condizioni originali e che siano utilizzati pezzi di ricambiaggio identici a quelli specificati.

(F)

Les normes de sécurité exigent que l'appareil soit remis à l'état d'origine et que soient utilisées les pièces de rechange identiques à celles spécifiées.

Pour votre sécurité, ces documents doivent être utilisés par des spécialistes agréés, seuls habilités à réparer votre appareil en panne.

LASER SAFETY

This unit employs a laser. Only a qualified service person should remove the cover or attempt to service this device, due to possible eye injury.



USE OF CONTROLS OR ADJUSTMENTS OR PERFORMANCE OF PROCEDURE OTHER THAN THOSE SPECIFIED HEREIN MAY RESULT IN HAZARDOUS RADIATION EXPOSURE.

AVOID DIRECT EXPOSURE TO BEAM

WARNING

The use of optical instruments with this product will increase eye hazard.

Repair handling should take place as much as possible with a disc loaded inside the player

WARNING LOCATION: INSIDE ON LASER COVERSIELD

CAUTION VISIBLE AND INVISIBLE LASER RADIATION WHEN OPEN AVOID EXPOSURE TO BEAM
ADVVARSEL SYNLIG OG USYNLIG LASERSTRÅLING VED ÅBNING UNDGÅ UDSÆTTELSE FOR STRÅLING
ADVVARSEL SYNLIG OG USYNLIG LASERSTRÅLING NÅR DEKSEL Å PNES UNNGÅ EKSPONERING FOR STRÅLEN
VARNING SYNLIG OCH OSYNLIG LASERSTRÅLNING NÅR DENNA DEL ÅR ÖPPNAD BETRAKTA EJ STRÅLEN
VARO! AVATT AESSA OLET ALTTIINA NÄKYVÄLLE JA NÄKYMÄTTÖMÄLLE LASER SÄTEILYLLE. ÄLÄ KATSO SÄTEESEEN
VORSICHT SICHTBARE UND UNSICHTBARE LASERSTRAHLUNG WENN ABDECKUNG GEÖFFNET NICHT DEM STRAHL AUSSETSEN
DANGER VISIBLE AND INVISIBLE LASER RADIATION WHEN OPEN AVOID DIRECT EXPOSURE TO BEAM
ATTENTION RAYONNEMENT LASER VISIBLE ET INVISIBLE EN CAS D'OUVERTURE EXPOSITION DANGEREUSE AU FAISCEAU

INSTRUCTIONS FOR HANDLING SEMI-CONDUCTORS AND OPTICAL UNIT

Electrostatic breakdown of the semi-conductors or optical pickup may occur due to a potential difference caused by electrostatic charge during unpacking or repair work.

1. Ground for Human Body

Be sure to wear a grounding band ($1\text{ M}\Omega$) that is properly grounded to remove any static electricity that may be charged on the body.

2. Ground for Workbench

Be sure to place a conductive sheet or copper plate with proper grounding ($1\text{ M}\Omega$) on the workbench or other surface, where the semi-conductors are to be placed. Because the static electricity charge on clothing will not escape through the body grounding band, be careful to avoid contacting semi-conductors with your clothing

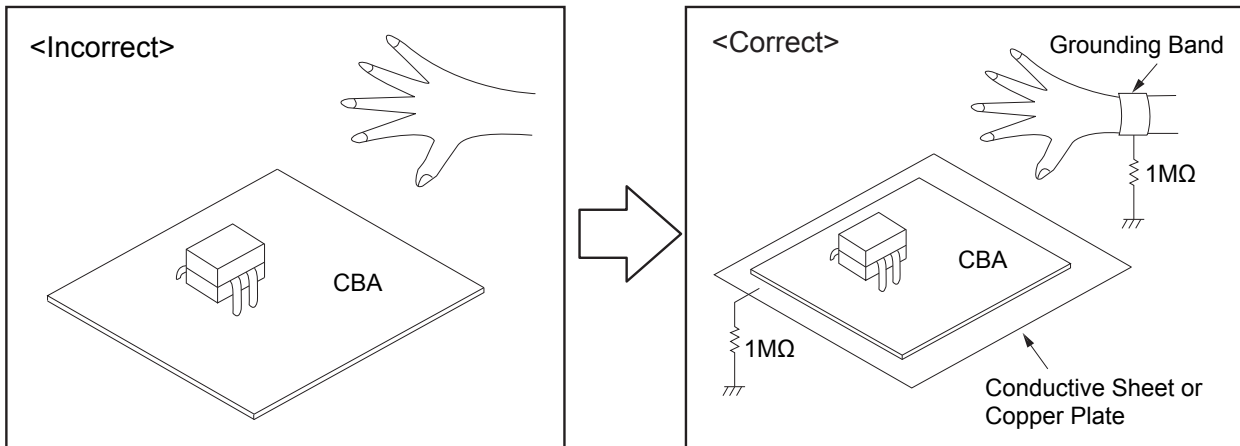

SPECIFICATIONS

CD player

• Audio performance

S/N ratio (1 kHz)	100 dB
Dynamic range (1 kHz)	100 dB
Total harmonic distortion (1 kHz)	0.01 %

S/N ratio (mono)

65 dB

Sensitivity (S/N 30 dB)

9 dB μ V (IHF)

• AM tuner

Range of receivable frequencies

522 to 1611 kHz

S/N ratio

40 dB

Sensitivity (S/N 20 dB)

55 dB μ V/m

Audio AMP

Rated output

(1 kHz, total harmonic distortion 0.7 %, 8 Ω) 40 W + 40 W

(1 kHz, total harmonic distortion 0.7 %, 6 Ω) 50 W + 50 W

Effective maximum output

(1 kHz, total harmonic distortion 10 %, 8 Ω) 50 W + 50 W

(1 kHz, total harmonic distortion 10 %, 6 Ω) 60 W + 60 W

Input sensitivity/impedance

AUX1 110 mV/24 k Ω

AUX2, AUX3 200 mV/32 k Ω

Frequency response (5 W, 8 Ω)

AUX input 5 Hz to 20 kHz (\pm 3 dB)

Total harmonic distortion (1 kHz, 5 W, 8 Ω)

AUX input 0.05 %

S/N ratio (10 W, 8 Ω , IHF-A)

AUX input 86 dB

Clock

Clock method

Within 1 – 2 minutes per month

DAB tuner section

Frequency range

174.928(5A)~239.200(13F)MHz (BAND III)

Sensitivity

-90 dBm

Signal-to-noise ratio

95 dB

THD+N

0.025 % (1 kHz)

Channel separation

70 dB (1 kHz)

Power supply

Power supply voltage/frequency

AC 230 V, 50/60 Hz

Power consumption

50W

Power consumption in standby mode

0.4 W

Tuner

• FM tuner

Range of receivable frequencies 87.5 to 108.0 MHz

Miscellaneous

External dimensions (width x height x depth)

280 x 111 x 302 mm

Weight

4.3 kg

DIMENSION

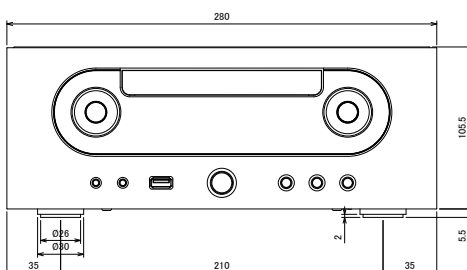
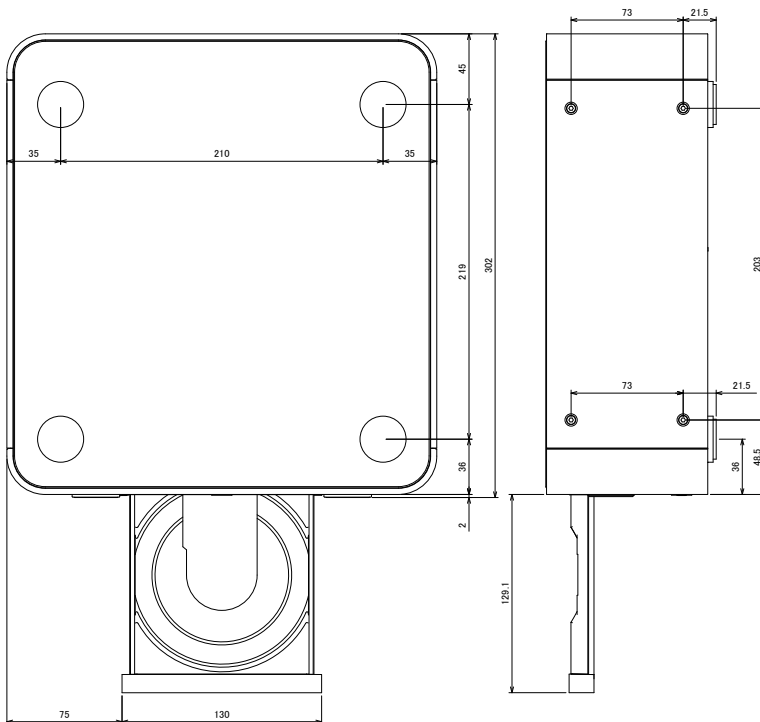
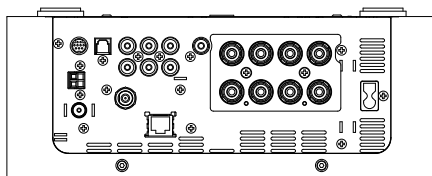

CAUTION IN SERVICING

About replace the ETHERNET PCB ASS'Y with a new one

- When you replace the ETHERNET PCB ASS'Y (8U-310055S), you need software updates.
 - (1) Replace the ETHERNET PCB ASS'Y with the 8U-310055S (MAC Address was written).
 - (2) After the M-CR603 built, DISC using firmware DM860 (Net (IMG)) to change the F Version. Refer to [**VERSION UPGRADE PROCEDURE OF FIRMWARE "1. How to update by disc"**] for the details of the Version up with disc.
 - (3) MAC Address Label pasted to Bottom is pasted to Mac Address Label (GEN8341; MAC ADDRESS SUB ASSY) of exchanged ETHERNET PCB ASS'Y and it substitutes it.
 - (4) The firmware is updated by DPMS. Refer to [**VERSION UPGRADE PROCEDURE OF FIRMWARE "2. How to update by DPMS"**] for the details of the Version up.

Initializing CD RECEIVER (Factory Reset)

CD RECEIVER initialization should be performed when the μ com, peripheral parts of μ com, and Digital PCB. are replaced.

1. Turn off the power using ON/STANDBY button, unplug the power cord.
2. Plug the power cord into a power outlet while pressing VOLUME▲ and ■ button simultaneously.
 - * Initialize.

Note: •All user settings will be lost and this factory setting will be recovered when this initialization mode. So make sure to memorize your setting for restoring after the initialization.

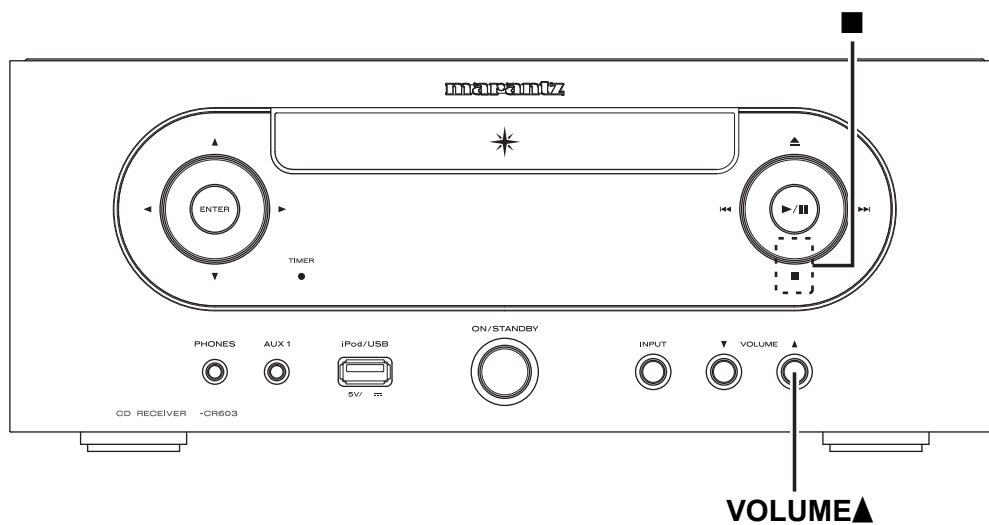

Service tools

Measuring Disc: CD/TCD-784
CD-R/TCD-R082W
CD-RW/TCD-W082W

* Refer to "MEASURING METHOD AND WAVEFORMS".

DISASSEMBLY



- Disassemble in order of the arrow of the figure of following flow.
- In the case of the re-assembling, assemble it in order of the reverse of the following flow.
- In the case of the re-assembling, observe "attention of assembling" it.
- If wire bundles are untied or moved to perform adjustment or parts replacement etc., be sure to rearrange them neatly as they were originally bundled or placed afterward.
Otherwise, incorrect arrangement can be a cause of noise generation.

CAUTION: Through great care is taken when manufacturing parts from sheet metal, there may in some rare cases be burrs on the edges of top cover which could cause injury if fingers are moved across them. Use gloves to protect your hands.

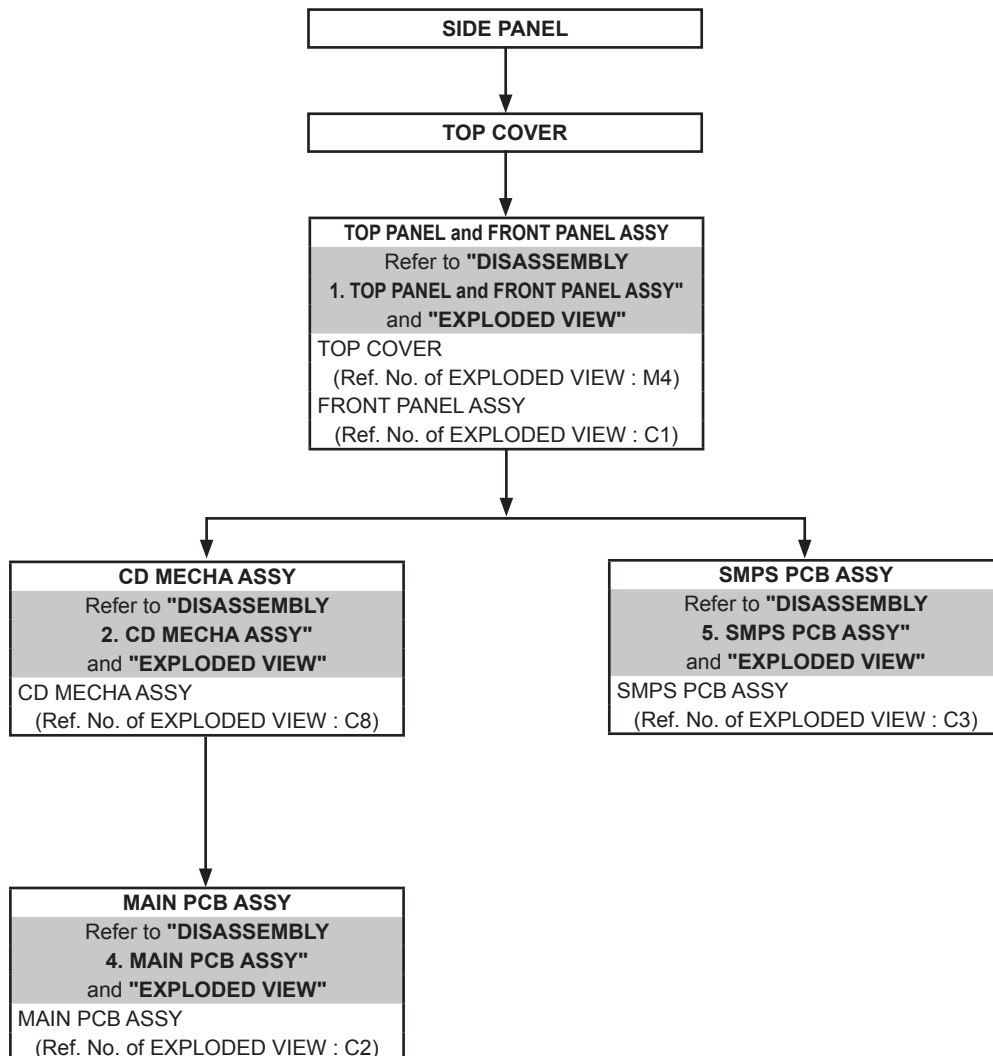

About the photos used for descriptions in the DISASSEMBLY" section.

- The direction from which the photographs used herein were photographed is indicated at "Direction of photograph: ****" at the left of the respective photographs.
- Refer to the table below for a description of the direction in which the photos were taken.
- Photographs for which no direction is indicated were taken from above the product.

The viewpoint of each photograph (Photography direction)

[View from above]

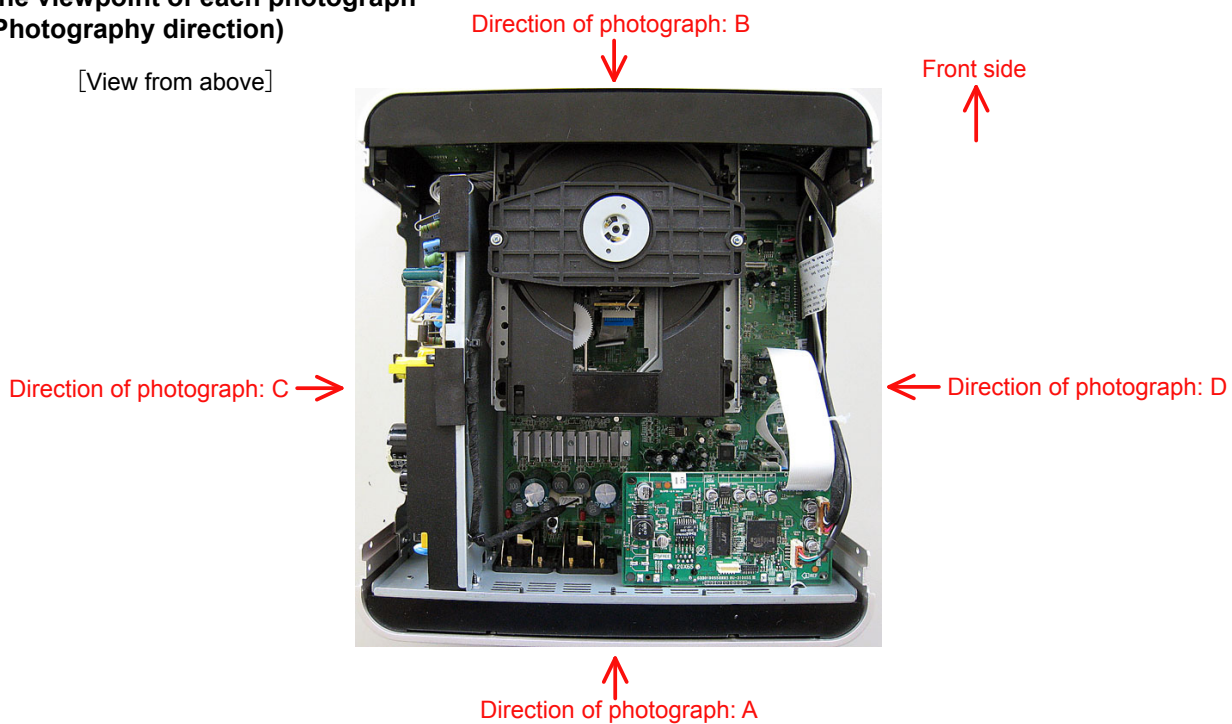

1. TOP COVER and FRONT PANEL ASSY

Proceeding : **SIDE PANEL** → **TOP COVER and FRONT PNAEL ASSY**

(1) Remove the screws.

View from bottom

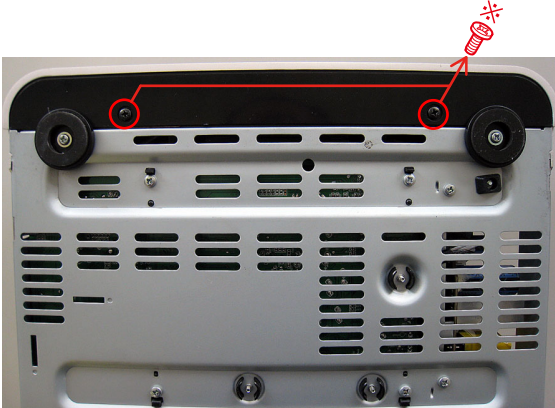

Direction of photograph: A



Direction of photograph: C

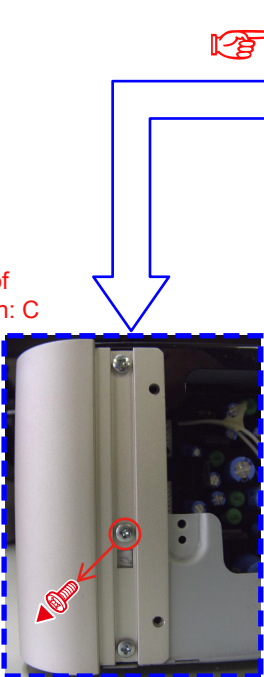

Direction of photograph: D

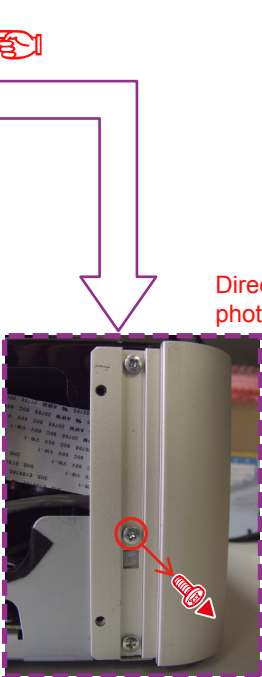

(2) Cut the wire clamp band, then disconnect the connector wires and the FFC Cable.

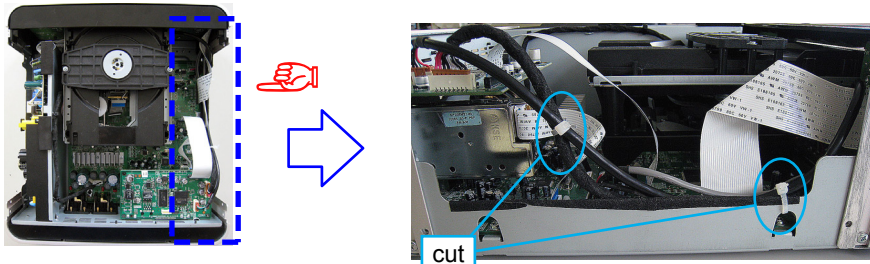

Direction of photograph: D

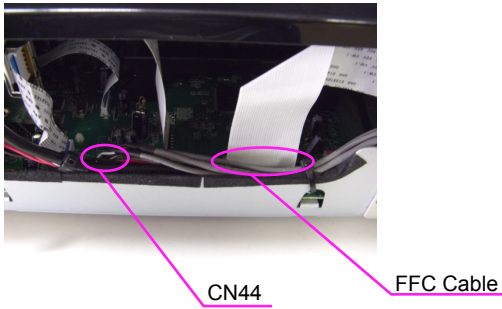

(3) Remove the TOP COVER and FRONT PANEL ASSY.

TOP COVER
and
FRONT PANEL ASSY

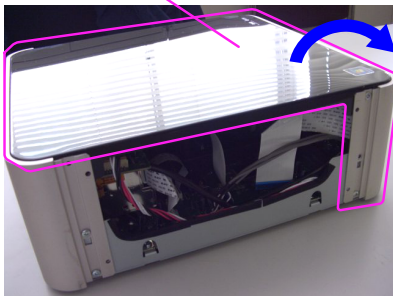

TOP COVER
and
FRONT PANEL ASSY

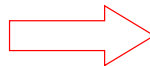

(4) Disconnect the connector wire.

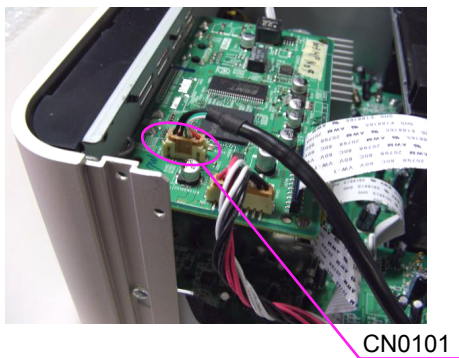

(4) Remove the TOP COVER.

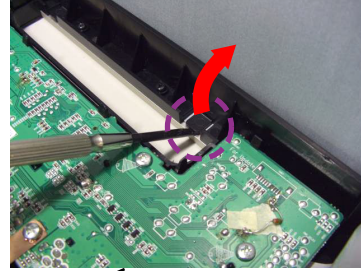
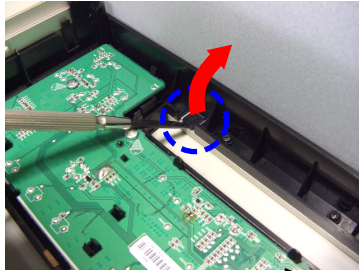
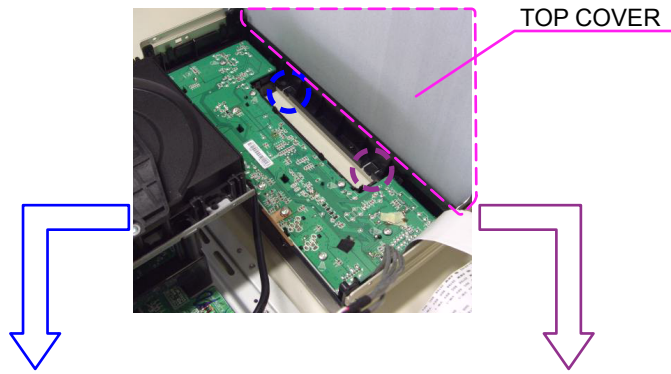

Please remove TOP COVER while lifting the hook.

Please refer to "EXPLODED VIEW" for the disassembly method of each PCB included in FRONT PANEL ASSY.

2. CD MECHA ASSY

Proceeding : **SIDE PANEL** → **TOP COVER and FRONT PNAEL ASSY** → **CD MECHA ASSY**

(1) Remove the screws.

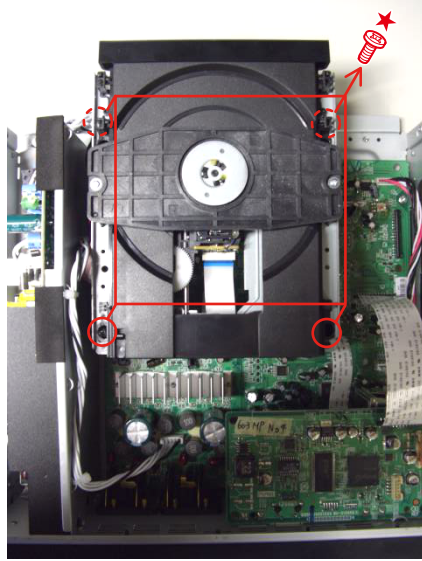

(2) Laser short-circuit in Pick-up of CD MECHANISM ASS'Y, then disconnect the connector wires and FFC cable. Be sure to wear a grounding band.

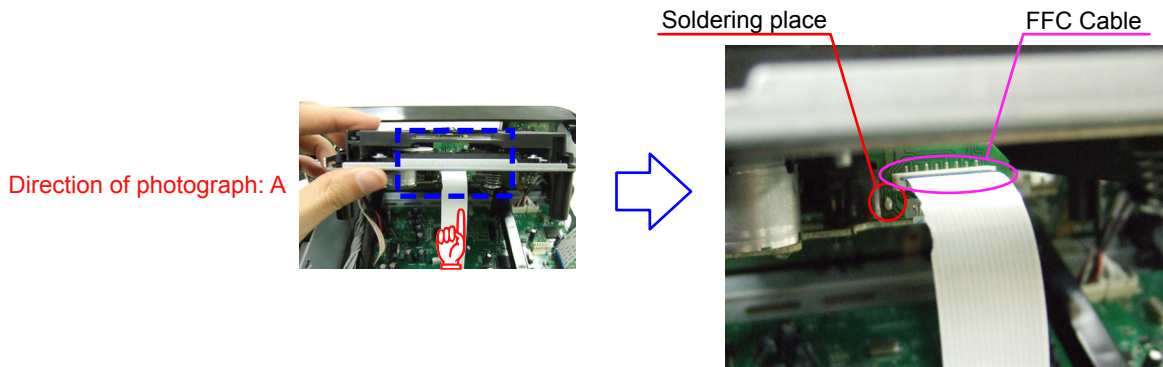

(3) Disconnect the connector wires.

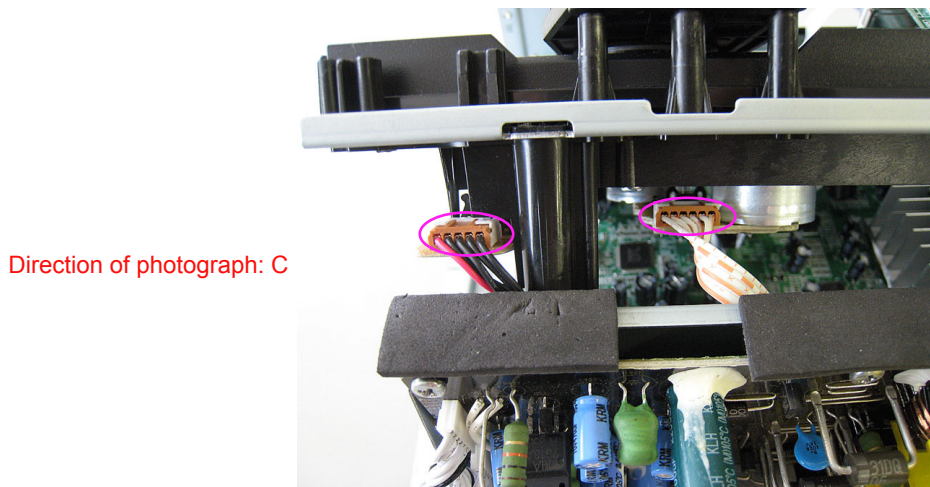

Please refer to "EXPLODED VIEW" for the disassembly method of each PCB included in ETHERNET PCB ASSY and DAB PCB ASSY, TUNER MODULE.

3. MAIN PCB ASSY

Proceeding : **SIDE PANEL** → **TOP COVER and FRONT PNAEL ASSY** → **CD MECHA ASSY**
→ **MAIN PCB ASSY**

(1) Remove the SHEET COVER.



Direction of photograph: A

(2) Remove the screws.

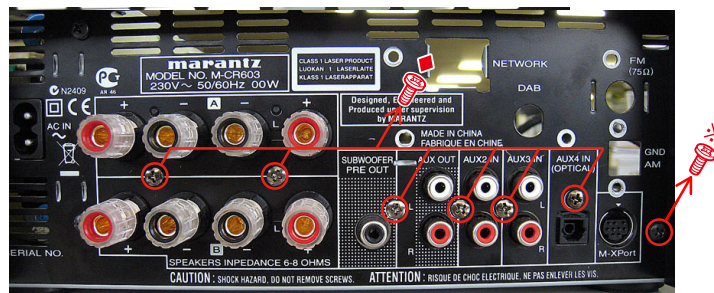

Direction of photograph: A

(3) Remove the screws

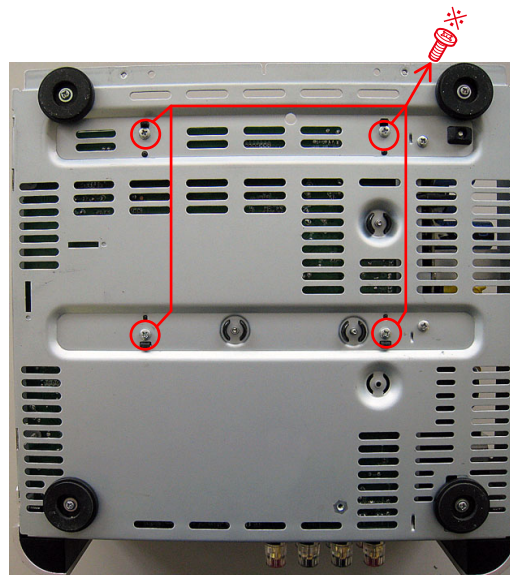

View from bottom

(4) Remove the SUPPORT MECHA.

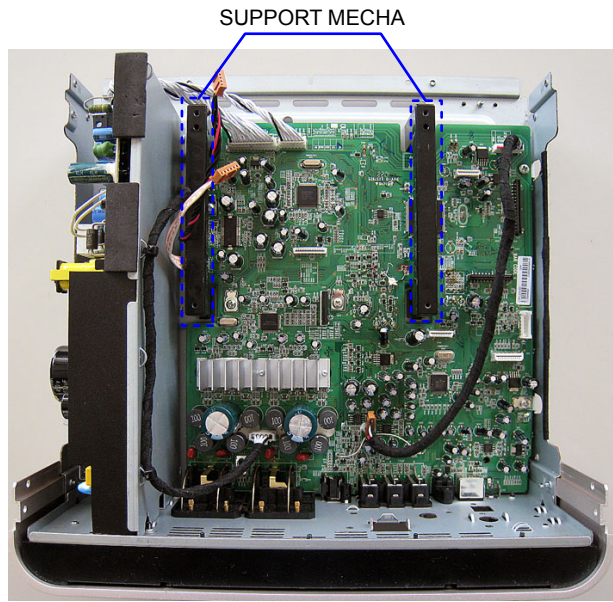

(5) Remove the screws, then disconnect the FFC cable and the connector wire.

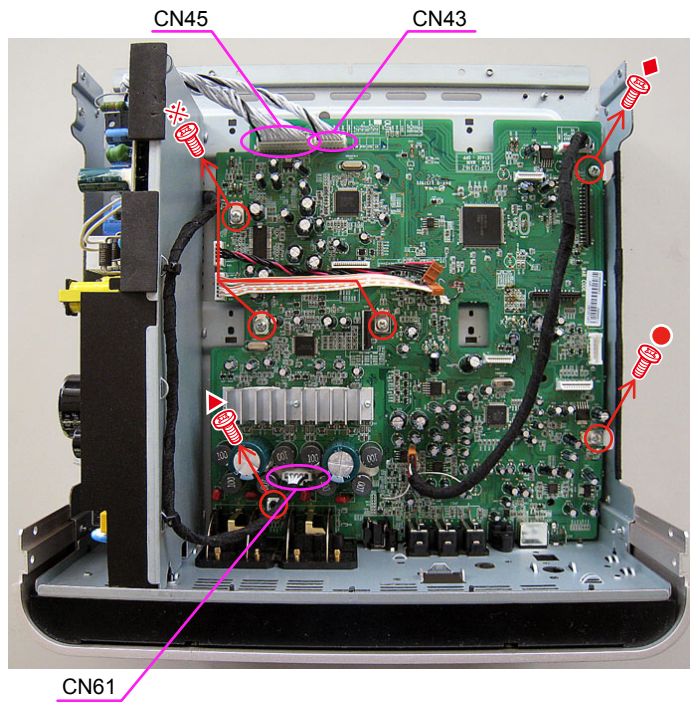

4. SMPS PCB ASSY

Proceeding : **SIDE PANEL** → **TOP COVER and FRONT PNAEL ASSY** → **CD MECHA ASSY**
→ **SMPC PCB ASSY**

(1) Remove the screws.

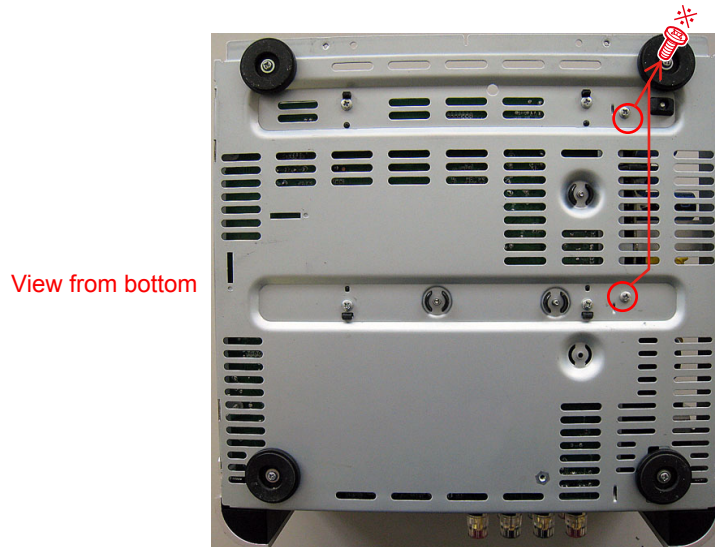

(2) Cut the wire clamp band, then disconnect the connector wires. Remove the screws.

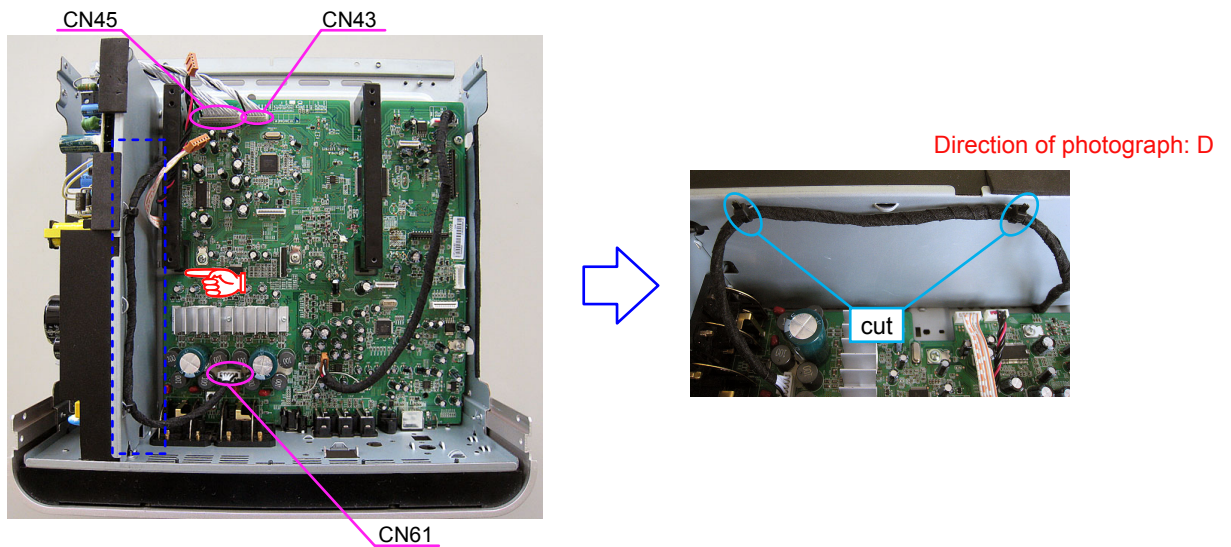

(3) Remove the screws.

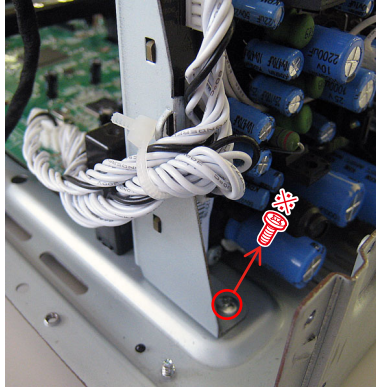
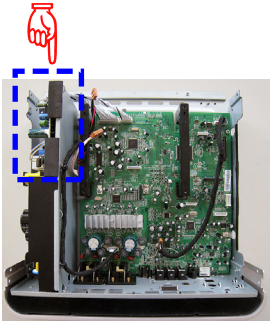

Direction of photograph: B

(4) Remove the screws.



Direction of photograph: A

NOTE HANDLING AND REPLACEMENT OF THE LASER PICK-UP

1. Protection of the LD

Short a part of the LD circuit by soldering. After connection to a circuit, remove the short solder.

2. Precautions when handling the laser CD mechanism

- Handle the laser pick-up so that it is not exposed to dust.
- Do not leave the laser pick-up bare. Be sure to cover it.
- If dust adheres on lens of the pick-up, blow it off with a blower brush.
- Do not shock the laser pick-up.
- Do not watch the light of the laser pick-up.

3. Cautions on assembling and adjustment

- Be sure that to the bench, jig, head of soldering iron (with ceramic) and measuring instruments are well grounded.
- Workers who handle the laser pick-up must be grounded.
- The finished mechanism (prior to anchoring in the set) should be protected against static electricity and dust. The mechanism must be stored that damaging outside forces are not received.
- When carrying the finished mechanism, hold it by the chassis body
- For proper operation, storage and operating environment should not contain corrosive gases. For example H₂S, SO₂, NO₂, Cl₂ etc. In addition storage environment should not have materials that emit corrosive gases especially from silicic, cyanic, formalin and phenol group. I the mechanism or the set, existence of corrosive gases may cause no rotation in motor.

4. Determining whether the laser pick-up is defective

- Check the Iop(Laser drive current). Check Iop in "SERVICE MODE". (Refer to 26 page.)
- If the present Iop (current) value becomes more than 50mA, replace the Traverse unit with a new one.
- No mechanical adjustment is necessary after the replacement.

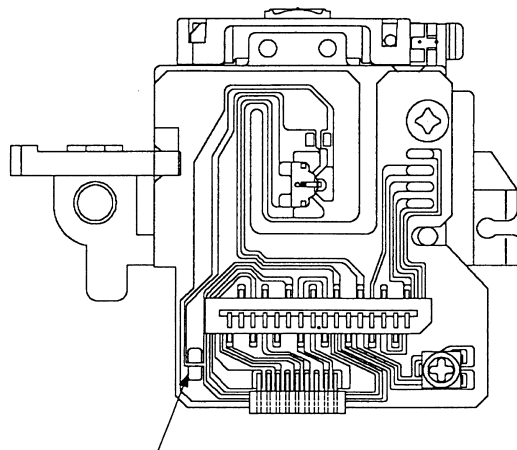

Protective soldering place for laser diode.

SPECIAL MODE



Special mode setting

Plug AC cord into power outlet while pressing buttons A and B.

Each button continue to press until the lit of ENTER and **▶/||**.

No.	Mode	Button A	Button B	Contents
1	Initialization mode (Factory Reset)	VOLUME UP	STOP	Initializing. Factory Reset
2	Initialization mode (User Reset)	VOLUME UP	VOLUME DOWN	Initializing. (Contents User's Guide is published)
3	Version display	CURSOR UP	-	Version Display
4	CD test mode	ON/STANDBY	VOLUME DOWN	Servo adjustment, Laser current, ON time
5	Heat Run mode	ON/STANDBY	INPUT	Heat run
6	Product mode 1	STOP	INPUT	Factory use.
7	Product mode 2	VOLUME UP	REVERSE-SKIP	Factory use.
8	Protection history mode	ENTER	CURSOR UP	Protection history view and reset
9	Hidden serial number mode	-	-	Factory use.
10	Update mode (by disc)	VOLUME DOWN	REVERSE-SKIP	Development/Factory use. The details cannot be disclosed.
11	DPMS compulsion update mode	VOLUME DOWN	FORWARD-SKIP	DPMS Up date Mode
12	Compulsion update mode (by RS232C)	PLAY/ PAUSE	REVERSE-SKIP	Development/Factory use. The details cannot be disclosed.
13	MAC Address rewrite mode	INPUT	FORWARD-SKIP	Development/Factory use. The details cannot be disclosed.
14	Update mode (display μ-com)	VOLUME UP	INPUT	Development/Factory use. The details cannot be disclosed.
15	Access to development server mode	INPUT	FORWARD-SKIP	Development/Factory use. The details cannot be disclosed.

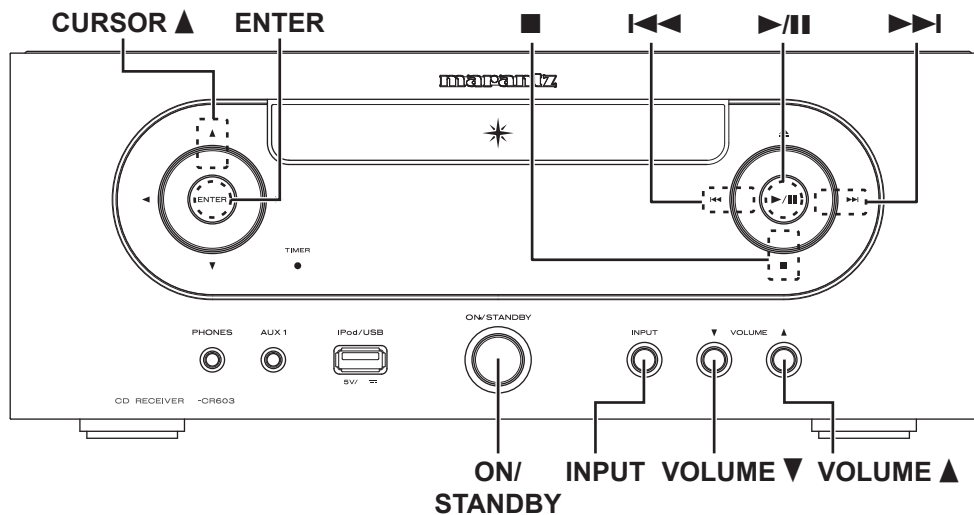

1. Initialization mode (Factory Reset)

Backup data initialization is carried out. Refer to Initialization Items.

After initialization, move on to normal mode.

CAUTION

Version information (such as rewriting failed log) Clear.

Clear the history of protection.

"Initial value of laser current"and"The accumulated laser on time"not cleared.

Power failure flag is not cleared.

Startup display

All lights display(2 seconds) - All off display(2 seconds)

All LED lighting (4 seconds)

Enter(white), (white), Timer LED(red)

"Factory Reset" displayed for 5 seconds.



Initialization Items (Default setting)

	Default
source	Internet Radio
TUNER(band)	FM(without DAB), DAB(with DAB)
DBB	OFF
BASS	0 dB
TREBLE	0 dB
BALANCE	CENTER
DIMMER	100%
VOLUME	0
TUNER Preset	Clear all
Favorite list	Clear all
Clock	00:00 (JP/EU), 12:00AM (NA)
TIMER (EVERYDAY/ONCE)	Timer function CD/Disc
	ON TIME 0:00 (JP/EU), 12:00AM (NA)
	OFF TIME 0:00
SPK Response	Flat
iPod mode	Direct mode
AUTO STANDBY	OFF
DAB Module	Module Initialization
Protection history	NO PROTECT
Auto Adjust	Time Zone : 1h /Summer Time : 0h
Network setting	DHCP (On)
PC Language	chinese(simplified)
Screen Saver	Off
IR Setting	Enable

2. Initialization mode (User Reset)

Backup data initialization is carried out. Refer to Initialization Items.

After initialization, move on to normal mode.

CAUTION

The difference is the following two points.

Version information (such as rewriting failed log) not cleared.

History of protection not cleared.

Startup display

"Initialized" displayed for 5 seconds.



All lights display(2 seconds) - All off display(2 seconds)

All LED lighting (4 seconds)

Enter(white), (white), Timer LED(red)

3. Version display

Menu items appear in the Add Version. Otherwise, normal operation.

To exit this mode, unplug the power cord.

Startup display

"Version" displayed for 5 seconds.



How to Display Version

Press INPUT and Cursor ◀, Cursor ▶ to select the Menu.

Press ENTER button.

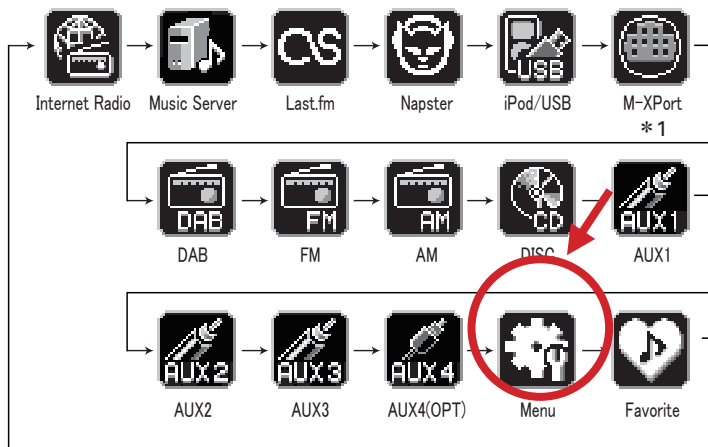

Pressing the ENTER button will be displayed below.

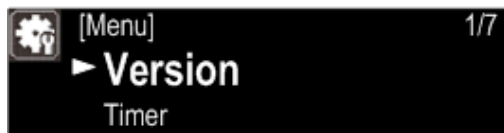

Press Cursor ▶



The version of the system-uP.

Press Cursor ▼



The version of the boot loader(system-uP).

Press Cursor ▼



The version of the display-uP.

Press Cursor ▼



The version of the boot loader(network-uP).

Press Cursor ▼



The version of the image(network-uP).

Press Cursor ▼



Serial number displayed.

(Serial: MZ_bccddddd, MZ: Fixed, b: One digit of the year, cc: Week number, dddddd: Serial number)

4. CD test mode

Startup display

"CD Test Mode" displayed for 5 seconds.



CDCD TEST MODE display

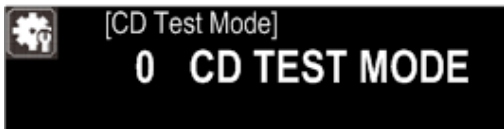

To exit this mode, unplug the power cord.

4.1. Before starting the test

Open the tray and disc.

Even if the disk is, the tray must let OPEN → CLOSE.

Press the ■ button to return to "0 CD TEST MODE".

4.2. Servo check

Press ►/ ■ button. Execute the following steps.

* ►/ ■ button continuously for over 1 second to switch directly to SUB CODE readout in step①.

Press the ■ button to return to "0 CD TEST MODE".

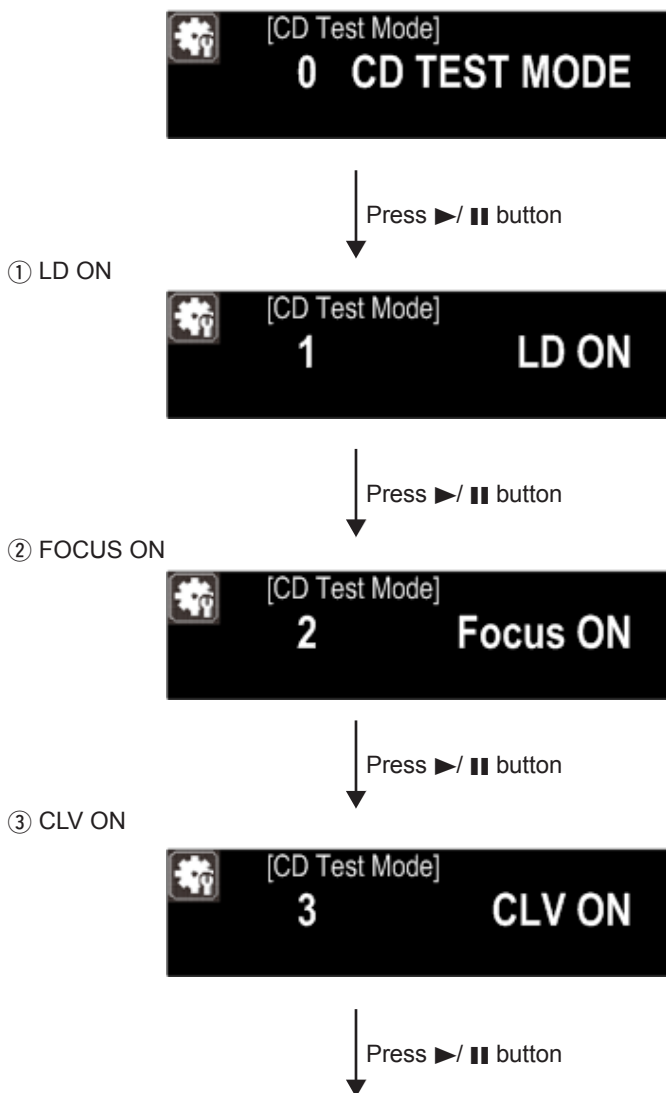

④ TRACKING ON

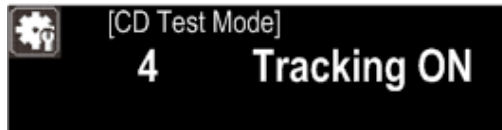

↓ Press ▶/|| button

⑤ SUB CODE readout (playback sound output)

The BER (Block Error Rate) generated in 1second's time is displayed of the display.

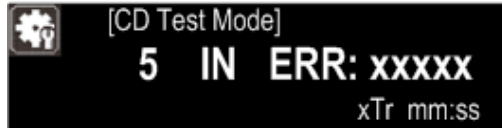

Press ◀◀ button ↑ ↓ Press ▶▶ button



Press ◀◀ button ↑ ↓ Press ▶▶ button

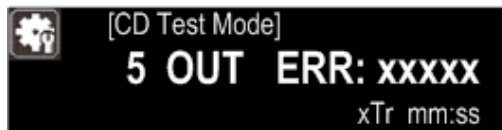

Inner (IN), Ataru Amane (MID), outer (OUT) to play go to three places, make the error count.

4.3. Pickup movement

In the stop mode, pickup moves in FWD (outwards) or REV (inwards) direction when ▶▶ or ◀◀ button pressed. Pickup movement stops when button released.(Pickup moves while button is pressed.)
When ◀◀ button pressed, move to stop operation after detection that inner switch has turned on.

4.4. All servo on and auto adjustment.

When Cursor ▲ button is pressed, all servos turn on, auto adjustment is performed and switch to playback operation.
(Playback sound output)

Stop (stop to the playback state after auto adjustment)

When ■ button is pressed, play operation and servo stop. The following will be displayed.
After stopping, conduct reading of auto adjust values.

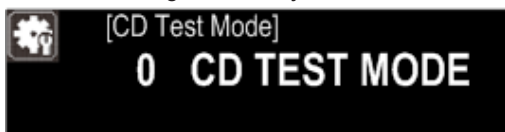

Stop (stop to the playback state after auto adjustment)

When Cursor ▲/ ▼ button is pressed, the adjustment values are displayed in the following order.

- ① FOCUS BALANCE
- ② FOCUS GAIN
- ③ TRACKING BALANCE
- ④ TRACKING GAIN
- ⑤ FOCUS OFFSET
- ⑥ TRACKING OFFSET
- ⑦ RFRP

(Caution) If you have not completed the adjustment, the value is not correct.

4.5. All servo on and auto adjustment.

When Volume ▲ button is pressed for over 1 second while the M-CR603 is in the CD TEST MODE, the laser turns on and the laser current is measured.

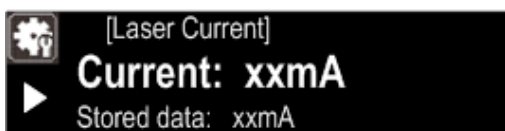

The laser drive current undergoes A/D conversion for calculation.

The current value is updated every 3 seconds.

Press the ■ button, CD TEST MODE display reappears.

Stored data is not cleared, even when the M-CR603 is reset(Factory/User).

Overwriting the stored data

When the ►/ || button is pressed for over 5 seconds while the laser current is displayed, the current value is stored in the EEPROM (overwriting the stored data).



Once rewriting is completed, the display in "Laser current display" reappears.

Rewriting is performed upon shipment from the factory and when the mechanism is replaced.

4.6. Accumulated laser on time display

When the Volume ▼ button is pressed while the M-CR603 is in the "CD TEST MODE" displayed, the accumulated laser on time is displayed.

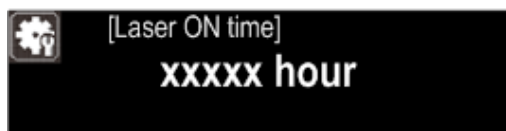

The laser drive times are added and the result is displayed. One count corresponds to 10 minutes. The accumulated laser on time is displayed in hours. Displays up to 10922 hours. Press the ■ button, CD TEST MODE display reappears. The count values are not cleared, even when the set is reset (Factory/User).

Count value is reset

When the ►/|| button is pressed for over 5 seconds while the accumulated laser on time is displayed, the count value is reset.



Count value is reset upon shipment from the factory and when the mechanism is replaced.

5. CD heat run mode

Startup display

"Heatrun Mode" displayed for 5 seconds. CD heat run mode



Press the Cursor ▲/▼ button to switch the mode. (H.R. Normal, H.R. Short, H.R. Chacking)

After loading the disc, press Enter button.

While heat run, the operation of each button is not valid

If an error occurs, display the error and stop operation at that point. Refer to Heat run error code table.

To exit this mode, unplug the power cord.

5.1. Normal heat run mode

Playing from the first track to last track on disc. After disc playback has finished, then tray open and close. And playback again.

The heat run repetition no. is incremented (increased by 1) when the tray is opened.

Repeat this operation.

[H.R. Normal] displayed.



Select "H.R.Normal", and press ENTER button.

Press the Cursor ▲ button to display the count.

5.2. Heat run Short mode

Playing last track on disc. After disc playback has finished, then tray open and close. And playback again. The heat run repetition no. is incremented (increased by 1) when the tray is opened. Repeat this operation.
[H.R. Short] displayed.

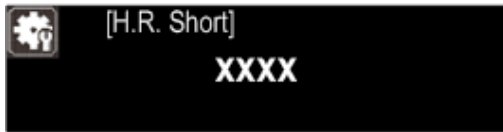

Select "H.R.Short", and press ENTER button.
Press the Cursor ▲ button to display the count.

5.3. Heat run chacking mode

TOC read the CD, the first song disk search, open / closed later, and again read TOC. The heat run repetition no. is incremented (increased by 1) when the tray is opened. Repeat this operation.
[H.R. Chacking] displayed.

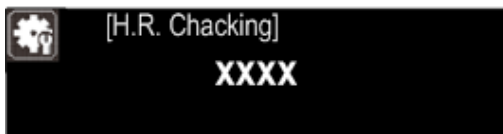

Select "H.R.Chacking", and press ENTER button.
Press the Cursor ▲ button to display the count.

5.4. Error display

Press the Cursor ▲/▼ to display the error information.



Heat run error code table

Error Code	Details of Error code
E1-00	Disc cannot be detected
E1-01	Tracking offset adjustment not possible
E1-02	Focus offset adjustment not possible
E2-00	Focus servo dropped during playback.
E2-01	Focus servo dropped during searching.
E2-03	Focus servo dropped during TOC reading.
E2-05	Focus servo dropped during manual search.
E2-10	Subcode can no longer be read during playback
E2-11	Subcode can no longer be read during searching
E2-12	Subcode can no longer be read during TOC reading
E2-14	Subcode cannot be read during pause
E2-15	Subcode cannot be read during manual search
E3-00	TOC could not be read within specified time
E3-01	PVD/SVD analysis could not be completed within specified time
E4-04	Search time out (The search was not completed within the stipulated time)
E4-05	Decoder bus error (Error in communications with CD decoder)
E5-00	Inner switch not on
E6-00	Inner switch not off
E8-00	Tray is not opened by the specified time.
E8-01	Tray is not closed by the specified time.
E9-00	CD Microprocessor error
E9-01	Other error

6. Product Mode 1

Startup display

"Product Mode1" displayed for 5 seconds.



Tested during production to perform the following settings automatically.

Tuner Preset

To exit this mode, unplug the power cord.

7. Product Mode 2

Startup display

"Product Mode2" displayed for 5 seconds.



Tested during production to perform the following settings automatically.

Sleep setting : 1 minutes

Auto Standby :1 minutes

Sleep setting and timer started.

Auto Standby to set up and will stand under the following conditions.

Auto Standby Conditions

CD/Disc : No Disc, Tray Open, Unsupported Disc or continue no operation and Stop state.

USB/iPod : No Connection or Unsupported Disc or continue no operation and Stop state.

Network : No Connection or Unsupported Disc or continue no operation and Stop state.

Digital In : No Input(unlock)

Portable In, M-XPort : No Input

To exit this mode, unplug the power cord.

8. Protection history display mode

Startup display

"Detect Protection" displayed for 5 seconds.



To exit this mode, unplug the power cord.

No history found



Thermal protection



Speaker short protection



Potential difference across the terminal detects that the speaker was more than DC9V

DC protect 1



Overvoltage of +B/-B

DC protect 2



Short of '+B/-B

Over current



Over-current detection digital amplifier

SubWoofer DC protect



Over voltage



Supply voltage is detected beyond the provisions

Protection history is reset.

When the Cursor ▲ button is pressed for over 5 seconds while the protection history is displayed, the count value is reset.



After the reset is complete, the display "No Protection".



Protection history is not cleared, even when the set is reset (Factory/User).

9. Hidden serial number mode

Serial number writing mode.
This mode is for production only, not described in detail.

10. Update mode (by disc)

Firmware update disc by.
When you replace the ETHERNET PCB ASS'Y (8U-310055S), you need software updates.
Refer to [**VERSION UPGRADE PROCEDURE OF FIRMWARE** "1. How to update by disc"].
Upgrade by DPMS. This mode describes a display only.
To exit this mode, unplug the power cord.

Startup display

"Disc Update Mode" displayed for 5 seconds.



The tray will open.

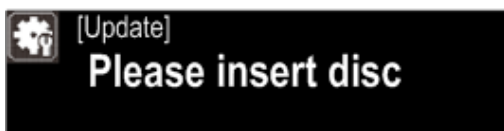

Insert disc.



The following states are displayed

Display update file.

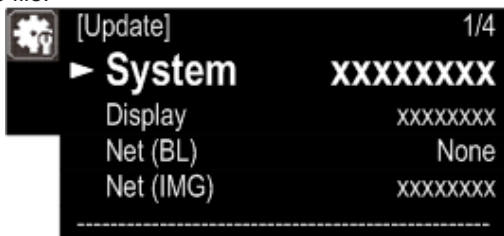

Updating display



Error code table

Error Code	Details of Error code
01	Tray Open/Close failure
02	No Disc
03	Disc error(TOC not read)
04	No update file
05	Update file read error
10	Update file check sum error
11	Erase failure
12	Write failure
13	Verify incorrect
20	Update file check sum error
21	Erase failure
22	Write failure
23	Verify incorrect
24	Communication error
30	Update failure check sum error
31	Erase failure
32	Write failure
33	Verify failure
34	Communication error
B2	DM8x0 firmware rewrite error information received

11. DPMS compulsion update mode

Update the firmware of DPMS.

Refer to [**VERSION UPGRADE PROCEDURE OF FIRMWARE "2. How to update by DPMS"**].

Error code table

- Preparation operation rewritten, Update error code checking. (Check ETHERNET unit)

Error Code	Details of Error code	Coping strategies
01	Login failed(DPMS Access Login Incorrect notification)	Reset and update again. Carry out the update in an environment that has little network load.
02	Login failed(DPMS Access Server Busy information)	Carry out the update in an environment that has little network load.
03	Login failed(DPMS Access link failure information)	Check the network connection. Carry out the update in an environment that has little network load.
04	Firm Info response acquisition error recieved	Check the network connection. Carry out the update in an environment that has little network load.
05	Firm Info response acquisition TimeOut	Check the network connection. Carry out the update in an environment that has little network load.
06	All Firm Info response acquisition error recieved	Check the network connection. Carry out the update in an environment that has little network load.
07	All Firm Info response acquisitionTimeOut	Check the network connection. Carry out the update in an environment that has little network load.
08	Main Firm Info response acquisition error recieved	Check the network connection. Carry out the update in an environment that has little network load.
09	Main Firm Info response acquisition TimeOut	Check the network connection. Carry out the update in an environment that has little network load.
0A	DownLoad failed ((NG)information recieved)	Check the network connection. Carry out the update in an environment that has little network load.
0B	DownLoad failed((ServerBusy) information recieved)	Check the network connection. Carry out the update in an environment that has little network load.
0C	DownLoad failed((connection failed)information recieved)	Check the network connection. Carry out the update in an environment that has little network load.

• Firm error codes at the main microprocessor rewritten. (Check main microprocessor)

Error Code	Details of Error code	Coping strategies
10	Firm Info response acquisition TimeOut(Main rewrite Firmware recived failure(TimeOut))	Turn off and on the power. Updating starts automatically.
11	Firm Info response acquisition recived error(Main rewrite Firmware recived failure(Error))	Turn off and on the power. Updating starts automatically.
12	Firm Info response acquisition recived error (Main rewrite Firmware recived data incorrect(CheckSumError))	Turn off and on the power. Updating starts automatically.
13	Rewrite failure (BlockErase failed before Main rewriting)	Turn off and on the power. Updating starts automatically.
14	Rewrite failure (BlockWrite failed before Main rewriting)	Turn off and on the power. Updating starts automatically.
15	Rewrite failure (Verify incorrect after Main rewriting)	Turn off and on the power. Updating starts automatically.
36	Login failure(DPMSAccess Login incorrect infomation)	Carry out the update in an environment that has little network load.
37	Login failure(DPMSAccess Server busy infomation)	Carry out the update in an environment that has little network load.
38	Login failure(DPMSAccess connection failed infomation)	Check the network connection. Carry out the update in an environment that has little network load.
39	Login failure(DPMSAccess access TimeOut)	Check the network connection. Carry out the update in an environment that has little network load.
3A	DownLoad failure(Download error (NG)information recieved)	Turn off and on the power. Updating starts automatically. Carry out the update in an environment that has little network load.
3B	DownLoad failure(Download error (ServerBusy) information recieved)	Turn off and on the power. Updating starts automatically. Carry out the update in an environment that has little network load.
3C	DownLoad failure(Download error (connection failed) information recieved)	Turn off and on the power. Updating starts automatically. Carry out the update in an environment that has little network load.

• Firm error codes at the display microprocessor rewritten. (Check display microprocessor)

Error Code	Details of Error code	Coping strategies
50	After download request, Login Failed	Carry out the update in an environment that has little network load.
51	After download request, Login Failed	Carry out the update in an environment that has little network load.
52	After download request, Login Failed	Check the network connection. Carry out the update in an environment that has little network load.
54	Error receiving response FirmInfo acquisition	Turn off and on the power. Updating starts automatically. Carry out the update in an environment that has little network load.
55	FirmInfo Get Response TimeOut	Turn off and on the power. Updating starts automatically. Carry out the update in an environment that has little network load.
56	Failure of DownLoad	Turn off and on the power. Updating starts automatically. Carry out the update in an environment that has little network load.
57	Failure of DownLoad	Turn off and on the power. Updating starts automatically. Carry out the update in an environment that has little network load.
58	Failure of DownLoad	Turn off and on the power. Updating starts automatically. Carry out the update in an environment that has little network load.
5A	C command error	Turn off and on the power. Updating starts automatically.
5B	L command error	Turn off and on the power. Updating starts automatically.
5C	Receive error update data	Turn off and on the power. Updating starts automatically.
5D	Receive error update data	Turn off and on the power. Updating starts automatically.
5E	Receive error update data	Turn off and on the power. Updating starts automatically.
5F	Receive error update data	Turn off and on the power. Updating starts automatically.
60	P command error	Turn off and on the power. Updating starts automatically.
61	I command error	Turn off and on the power. Updating starts automatically.
62	Launch failure	Turn off and on the power. Updating starts automatically.
70	T command error	Turn off and on the power. Updating starts automatically.

- DM8x0 system Firm error codes when rewriting. (Check ETHERNET unit)

Error Code	Details of Error code	Coping strategies
A0	Net not connected	Check the network connection. Carry out the update in an environment that has little network load.
A1	Net Connection TimeOut can not get status	Check the network connection. Carry out the update in an environment that has little network load.
A2	Login failed	Check the network connection. Carry out the update in an environment that has little network load.
A3	Login failed	Check the network connection. Carry out the update in an environment that has little network load.
A4	Login failed	Check the network connection. Carry out the update in an environment that has little network load.
A6	Error receiving response FirmInfo acquisition	Turn off and on the power. Updating starts automatically. Carry out the update in an environment that has little network load.
A7	FirmInfo Get Response TimeOut	Turn off and on the power. Updating starts automatically. Carry out the update in an environment that has little network load.
A8	Net not connected	Check the network connection. Carry out the update in an environment that has little network load.
A9	Net Connection TimeOut can not get status	Check the network connection. Carry out the update in an environment that has little network load.
AA	After download request, Login Failed	Check the network connection. Carry out the update in an environment that has little network load.
AB	After download request, Login Failed	Check the network connection. Carry out the update in an environment that has little network load.
AC	After download request, Login Failed	Check the network connection. Carry out the update in an environment that has little network load.
AE	Failure of DownLoad	Turn off and on the power. Updating starts automatically. Carry out the update in an environment that has little network load.
AF	Failure of DownLoad	Turn off and on the power. Updating starts automatically. Carry out the update in an environment that has little network load.
B0	Failure of DownLoad	Turn off and on the power. Updating starts automatically. Carry out the update in an environment that has little network load.
B2	Update error	Turn off and on the power. Updating starts automatically. Carry out the update in an environment that has little network load.

Failure to update, After the move again 8x0 self display retry processing

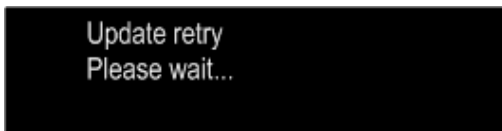

12.Compulsion update mode (by RS232C)

Firmware update using PC via RS232C
 Upgrade by DPMS. No display.
 To exit this mode, unplug the power cord.

13.MAC Address rewrite mode

Rewriting the MAC address mode.
 Production / development for, there is no detailed description.
 To exit this mode, unplug the power cord.

14.Update mode (display μ -com)

Rewriting of display microprocessor.
 Production / development for, there is no detailed description.
 To exit this mode, unplug the power cord.

15.Access to development server mode

Production / development for, there is no detailed description.
 To exit this mode, unplug the power cord.

ABOUT REPLACE THE MICROPROCESSOR WITH A NEW ONE

When replaced of the U-PRO (Microprocessor) or the Flash ROM, confirm contents of the following.

PWB Name	Ref. No.	Description	After replaced	Remark
DISPLAY	IC81	R5F64169DFD	B	
MAIN	IC11	R5F64169DFD	B	

After replaced

- A** : Mask ROM (With software). No need write-in of software to the microprocessor.
- B** : Flash ROM (With software). Usually, no need write-in of software. But, when the software was updated, you should be write-in of the new software to the microprocessor or flash ROM. Please check the software version.
- C** : Empty Flash ROM (Without software). You should be write-in of the software to the microprocessor or flash ROM. Refer to "Update procedure" or "writing procedure", when you should be write-in the software.

VERSION UPGRADE PROCEDURE OF FIRMWARE

NOTE: When you replace the ETHERNET PCB ASS'Y (8U-310055S), you need software updates. Refer to [CAUTION IN SERVICING "About replace the ETHERNET PCB ASS'Y with a new one"].



1. How to update by DISC

1.1. Procedure of making CD-R

- (1) Please download zipped file, and unzip on your PC.
 For EU : MCR603EU_XXXXXXXXXX-xxxx.zip
 For NA : MCR603NA_XXXXXXXXXX-xxxx.zip

- (2) The following 3-file will be appeared.
 M_CR603_SYS_000xxx.BIN
 M_CR603_OEL_0000xx.BIN
 and
 M_CR603_BCI_CREUNM.BIN(EU)
 or
 M_CR603_BCI_CRNANM.BIN(NA)
 or
 M_CR603_BCI_CRJPNM.BIN(JP)

- (3) Please burn 3-file to CD-R with the following conditions.
 - ① Multi Session : No
 - ② File System : ISO9660+Joliet
 - ③ Mode: MODE1
 - ④ Writing speed: 8~16 speed (according ability of CD-R)
 - ⑤ Writing method: Disc at Once (Finalize(Close))

1.2. Procedure of updating

Pressing the VOLUME▼ and ◀▶ buttons for simultaneously, plug the AC cord into a power outlet.

- (1) "Disc Update Mode" is indicated approximately 5 seconds.



- (2) Open the Tray.



(3) Please put CD-R on Tray, and press ▲ button.



(4) After loading CD-R, version number of firmware will be indicated.

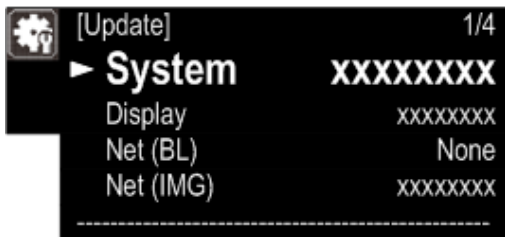

xxxxxx : Version number

(5) If there is no any firmware of updating, [xxxxxx="None"] will be indicated.

Please confirm version of each firmware by Cursor ▲ / ▼ buttons.

(6) Press "Enter" button, unit will update firmware automatically.

Display will be indicated procedure of updating firmware.

First line : Version of updating firmware/ a number of firmware

Second line : Rest time and progress of updating (...%)

Third line : Name of Microprocessor and Version

※ while updating firmware, any buttons of R/C and Front panel are not worked.

---Order of updating---

- ① Network microprocessor (Boot Loader)
- ② Network microprocessor (Image)
- ③ Microprocessor for indication
- ④ Microprocessor for system

(7) After 27 minutes, unit will be updated completely, and open the tray automatically.

(8) Remove CD-R, and pull out AC cord from AC wall socket.

(9) Please initialize unit after updating.



① Please insert AC cord to AC wall socket while pressing Volume▲ button and Volume▼ button.

② After power LED is indicated, remove your finger.

③ "Initialize" will be indicated 5 seconds.

④ Pull out AC cord from AC wall socket.

(10) Updated unit completely.

1.3. Trouble Shooting

If you find the following Error codes, please solve root cause of malfunction.

(1) If updating is failed, the following ERROR indication is displayed.

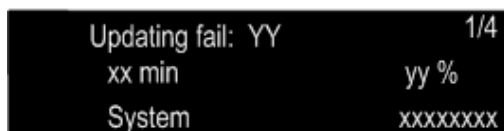

First line (Error number): "Updating fail: YY, n/N"YY: Error number

Second line (Time on error): "xx min yy%"

Third line (name of firmware)

Error code table

Error Code	Details of Error code
① Error before updating	
01	Tray Open/Close failure
02	No Disc
03	Disc error(TOC not read)
04	No update file
05	Update file read error
② Error at writing System Microprocessor	
10	Update file check sum error
11	Erase failure
12	Write failure
13	Verify incorrect
③ Error at writing Display Microprocessor	
20	Update file check sum error
21	Erase failure
22	Write failure
23	Verify incorrect
24	Communication error
④ Error at writing DM8x0	
30	Update failure check sum error
31	Erase failure
32	Write failure
33	Verify incorrect
34	Communication error
B2	DM8x0 firmware rewrite error information received

1.4. Notice of updating firmware

(1) When unit is updating firmware on item "1.2. Procedure of updating (6)", do not turn off the power, or pull out AC cord from AC wall socket.

(2) **If power supply stop to supply microprocessor, unit will be broken.**

- ① When AC cord is pulled while updating System firmware.
⇒ System microprocessor will be broken. Please replace it.
- ② When AC cord is pulled while updating Display firmware.
⇒ Display microprocessor will be broken. Please replace it.
- ③ When AC cord is pulled while updating DM870Net (IMG) firmware.
⇒ Please update firmware by CD-R again.

(3) When updating is not finished (not 100%), but tray opens automatically over 27 minutes. Probably unit will be updated firmware completely, therefore please confirm version of firmware. If no, please update again.

(4) After 35 minutes, try does not open or try does open with error indication, please update firmware of unit with CD-R again.

2. How to update by DPMS

You can update by downloading the latest firmware from the Internet.

1. Connecting to the Network

- (1) System Requirement
 - Internet Connection by Broadband Circuit
 - Modem
 - Router
 - Ethernet cable (CAT-5 or greater recommended)
- (2) Setting

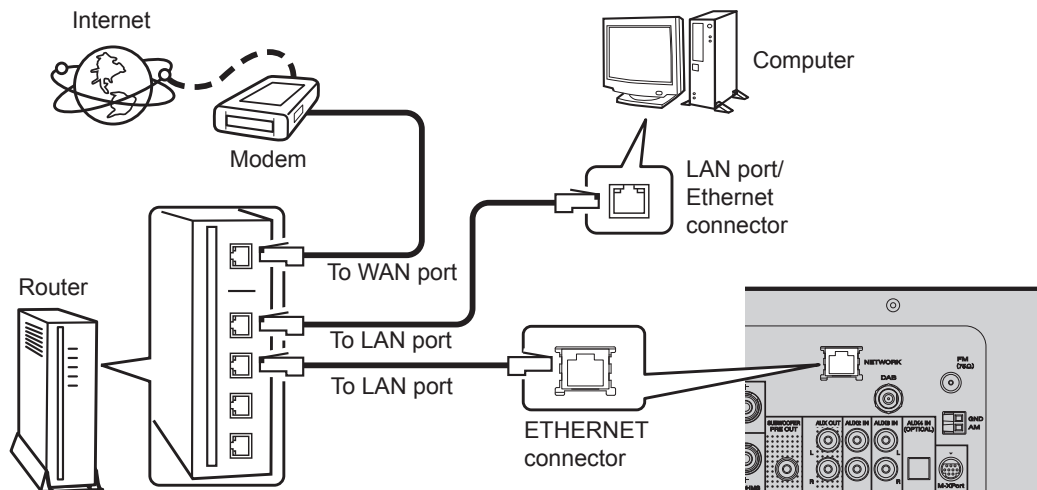

2. Check for Update and Update

Check if the latest firmware exists. You can also check approximately how long it will take to complete an update.

- (1) Press ON/STANDBY button to turn on power.
- (2) Press INPUT and Cursor ◀ / ▶ buttons to select the Menu. Press the ENTER button.
 - Press Cursor ▲ / ▼ buttons select to Others. Press <ENTER>.
 - Press Cursor ▲ / ▼ buttons select to Firmware Update. Press <ENTER>.
 - Press Cursor ▲ / ▼ buttons select to CHECK For UPDATE.
- (3) Press the ENTER button.
 - The latest version of the firmware uploaded to the web is displayed.
 - If the latest firmware version is on the web, proceed to (4).
 - If the latest firmware is already installed, press the MENU button to close the Update menu.
- (4) Press ENTER button. Select YES, then press ENTER button.
- (5) To start the update.

--- Cautions on Firmware Update ---

- In order to use these functions, you must have the correct system requirements and settings for a broadband Internet connection.
- Do not turn off the power until updating is completed.
Even with a broadband connection to the Internet, approximately about 1 hour is required for the updating procedure to be completed.
Once updating starts, normal operations on the M-CR603 cannot be performed until updating is completed.
Also, setting items of the image adjustment may be initialized.
Make a note of the settings before updating, and set them again after updating.

TROUBLE SHOOTING

1. OLED dosen't light

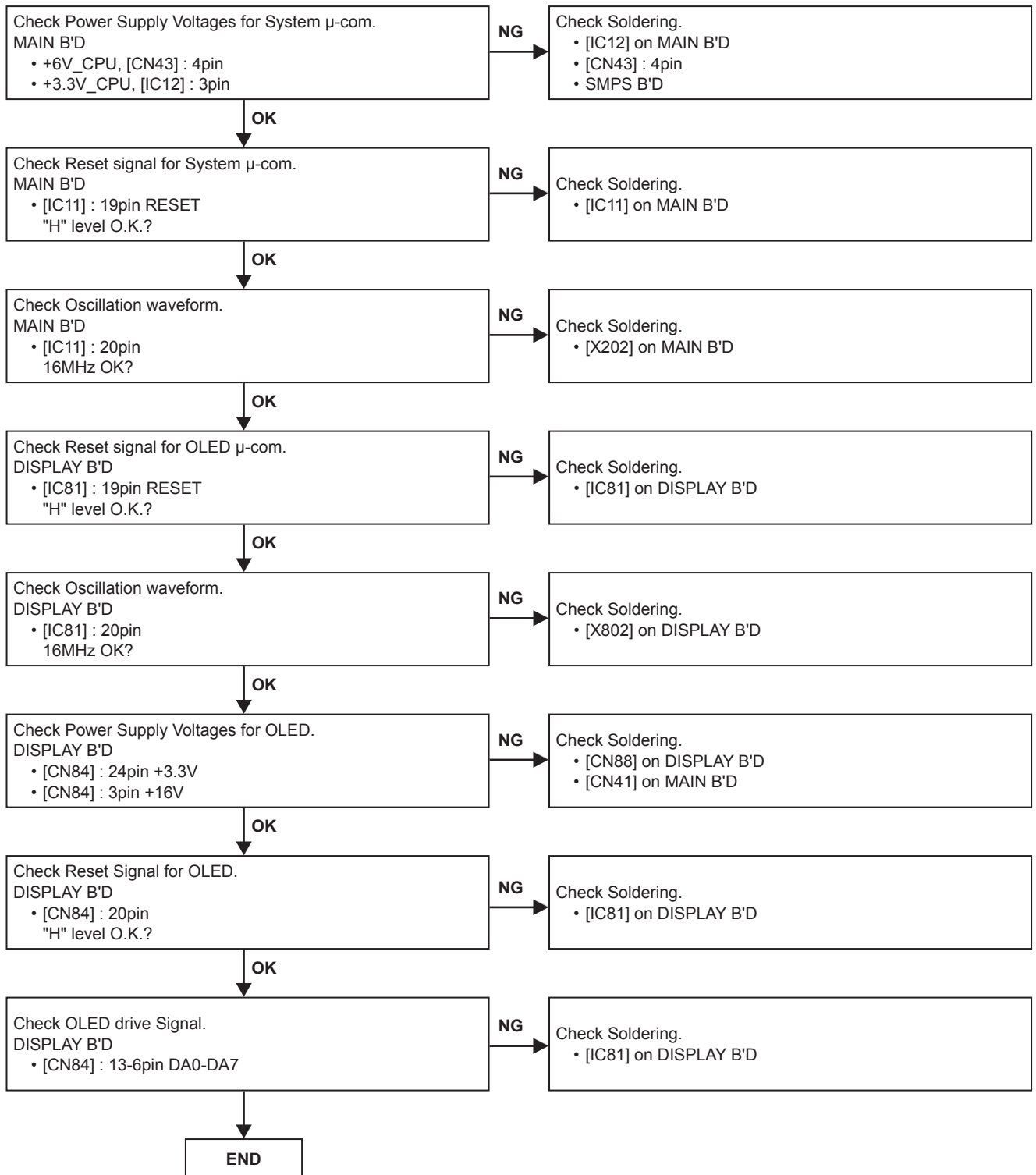

2. No Sound, Noise generated

2.1. COMMON

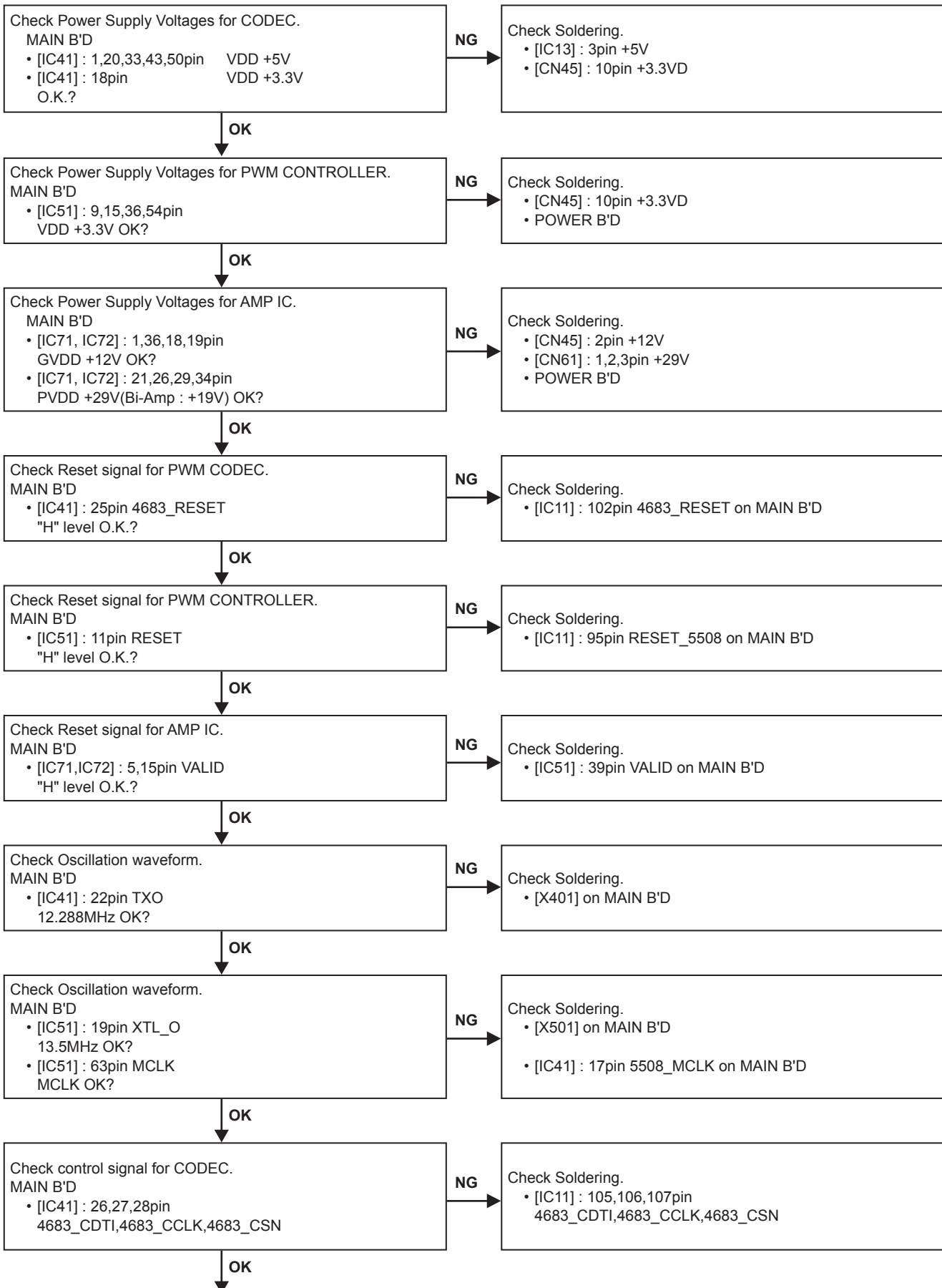

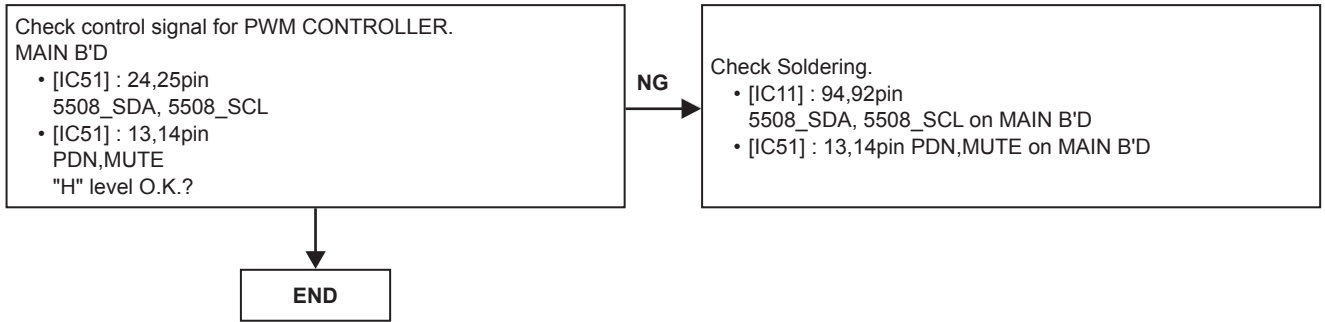

2.2. CD PLAY

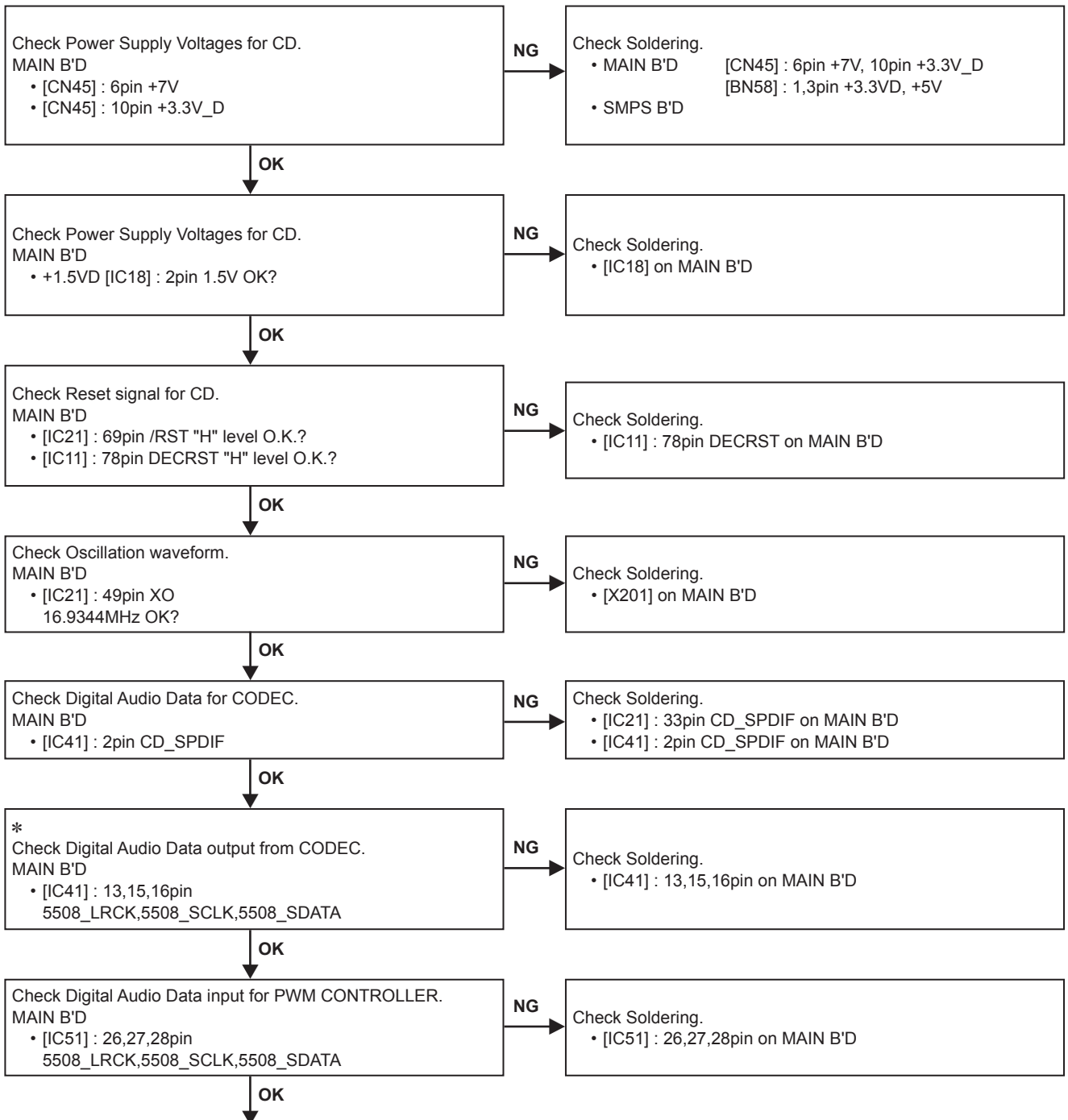

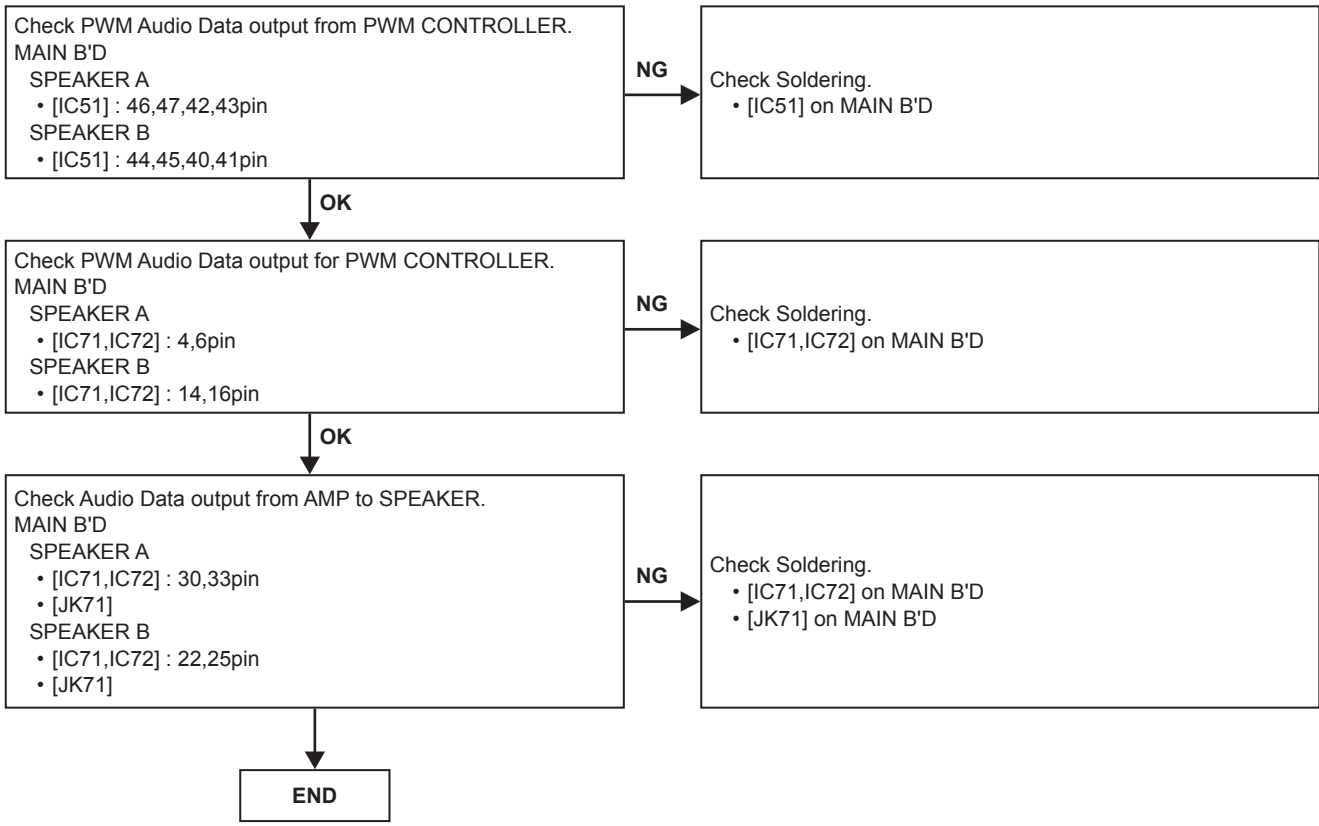

2.3 . AM/FM TUNER-in

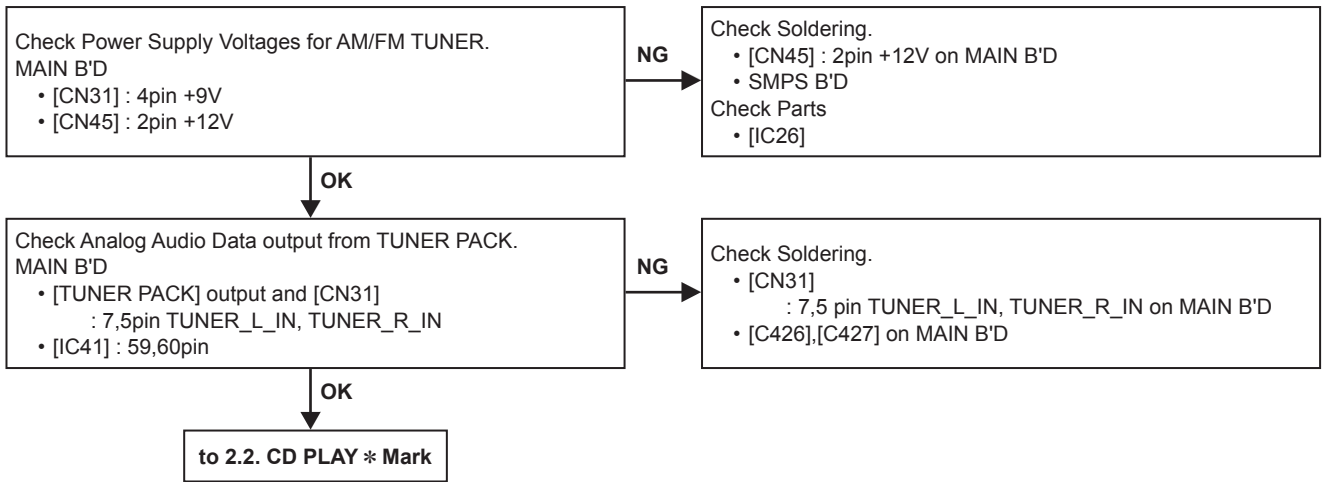

2.4 . DAB TUNER-in (N Version)

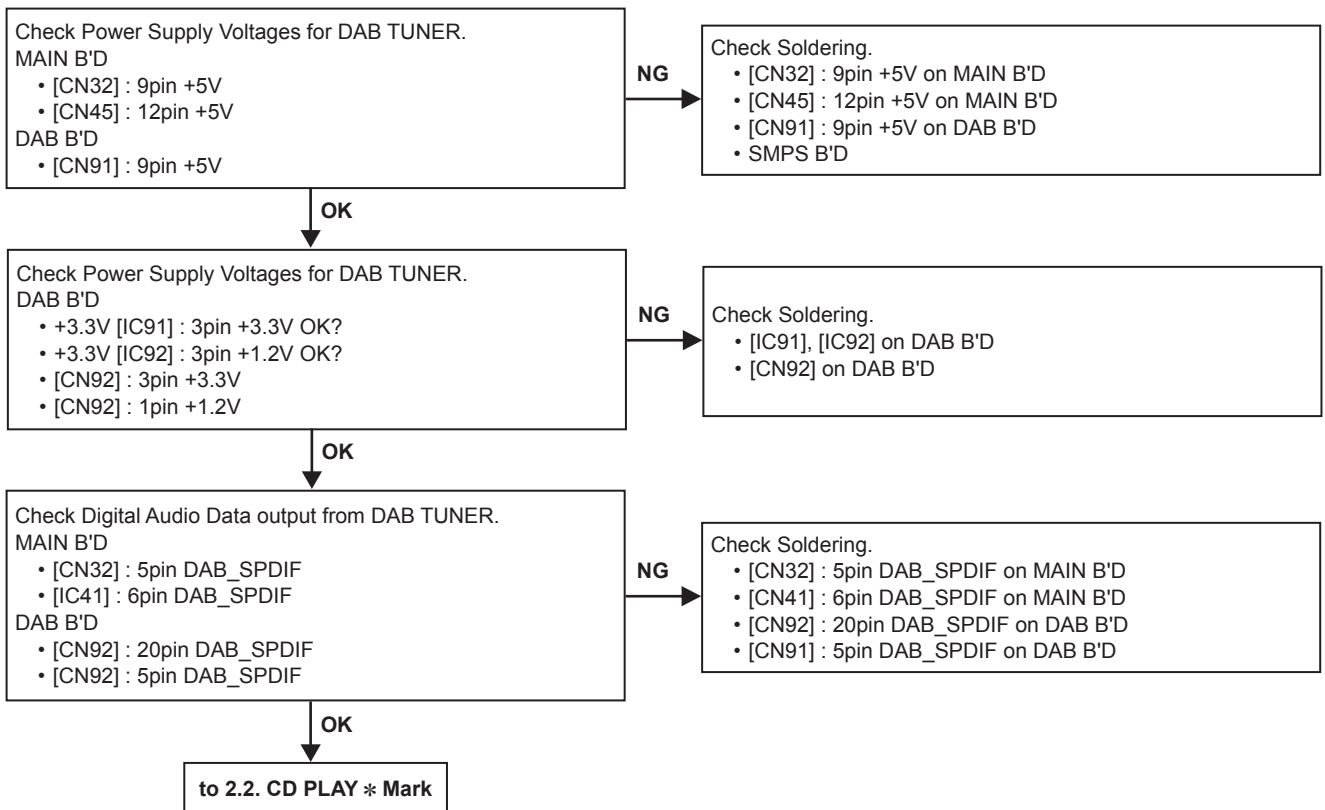

2.5. AUX1 (Front-in)

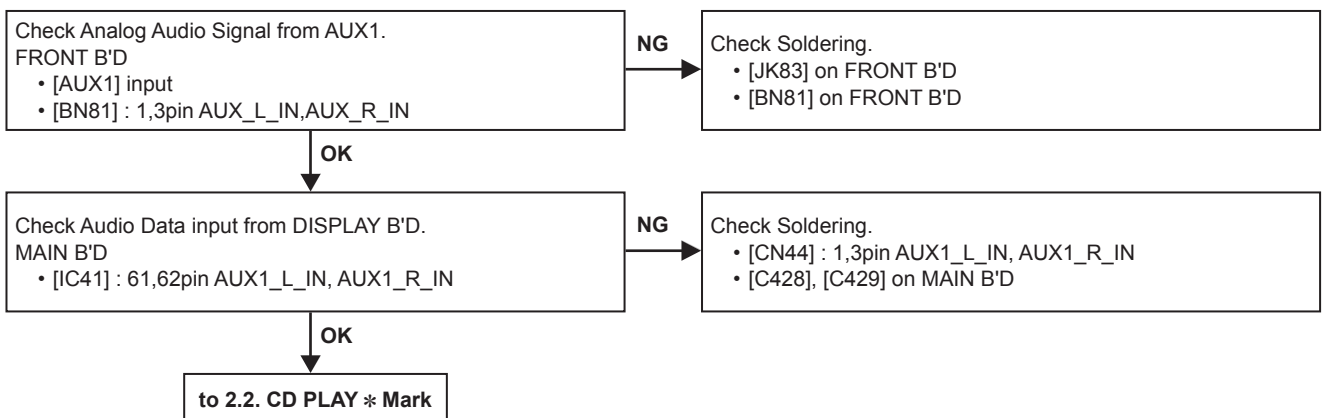

2.6 . AUX2/AUX3

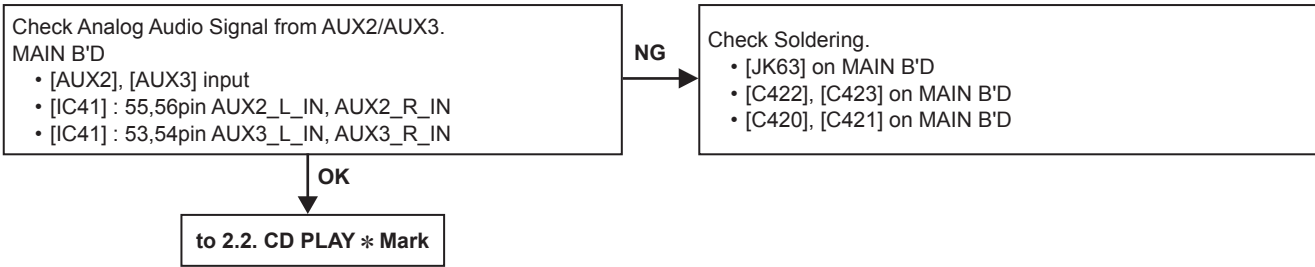

2.7. AUX4 (OPTICAL-in)

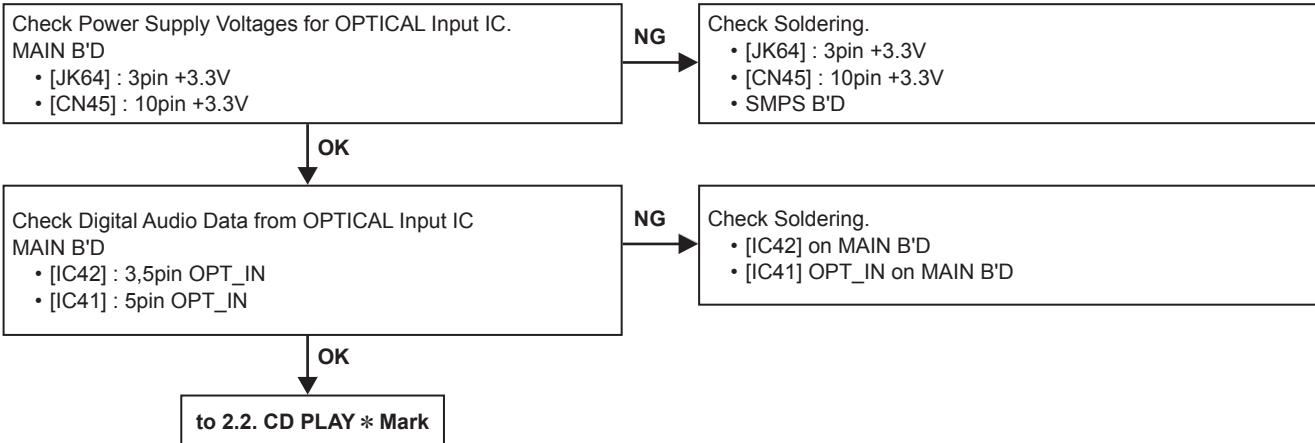

2.8 . USB/ETHERNET

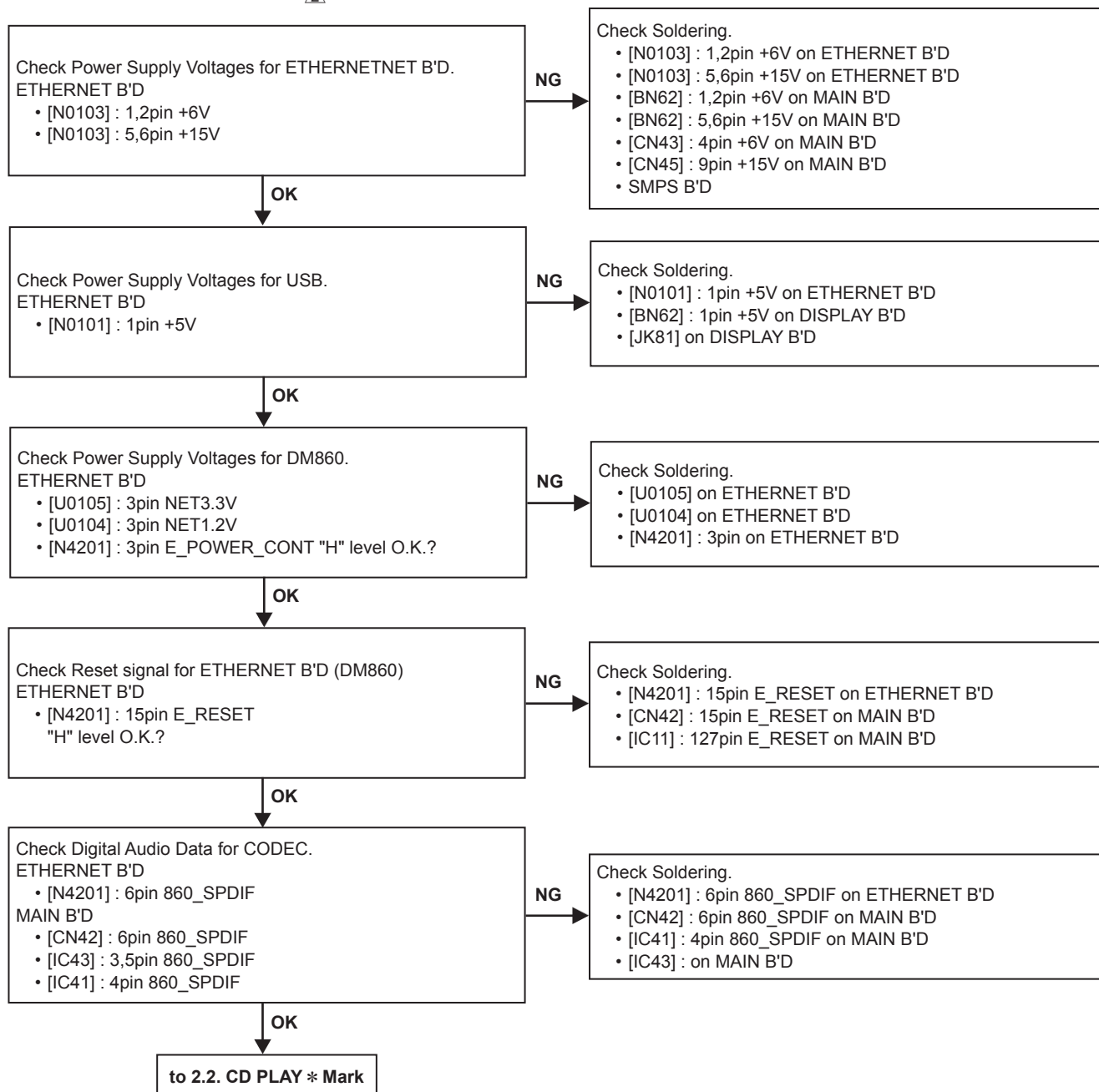

MEASURING METHOD AND WAVEFORMS

To check the waveforms, the GND (-) probe of the oscilloscope to specified reference voltage.
(Except for inner SW, TRVSW)

NOTES

Measuring Disc: CD/TCD-784
CD-R/TCD-R082W
CD-RW/TCD-W082W

(It is better to use wires for extending between the probe and test points.)

- When watching the HF waveform, use the extending wire as short as possible.
- When HF waveform is noisy or cannot discriminate the eye-pattern, replace the Traverse Unit after measuring the top.
- Point ① ~ ⑮ is measured with the point shown below.

1. MAIN PCB : TEST POINT

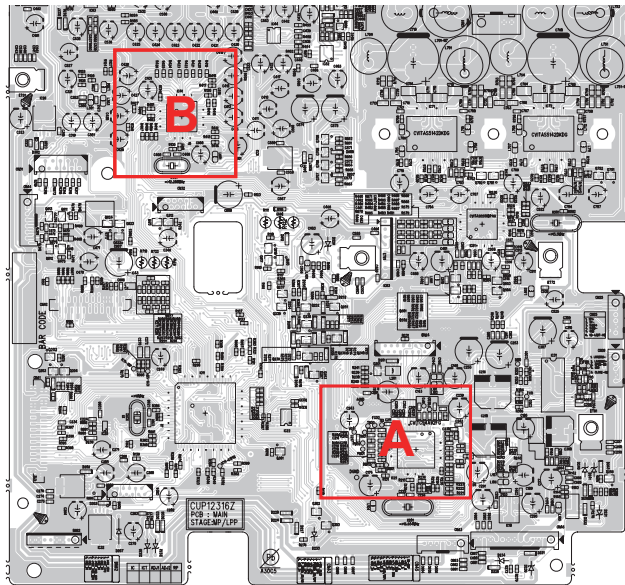

Component side

Detail A

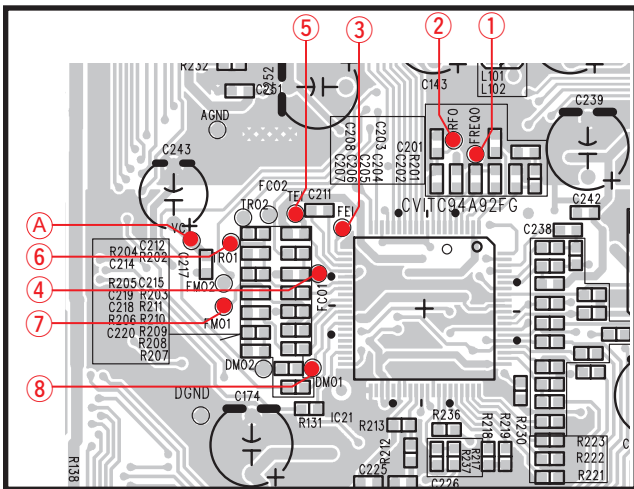

Detail B

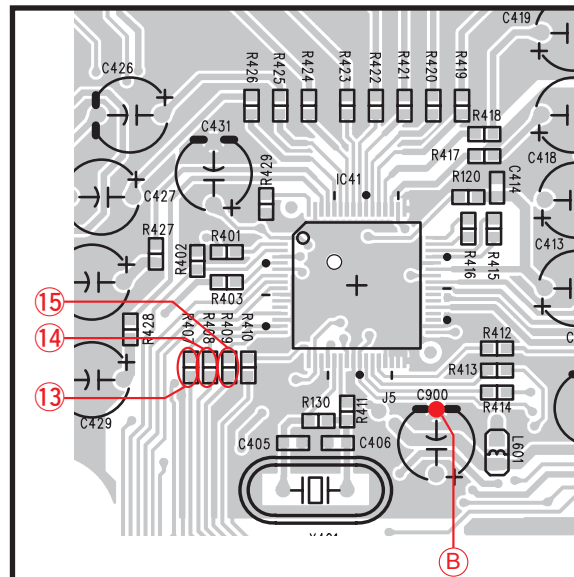

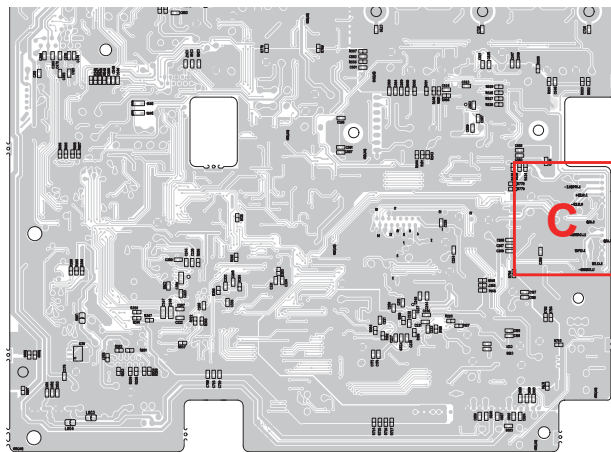

Foil side

Detail C

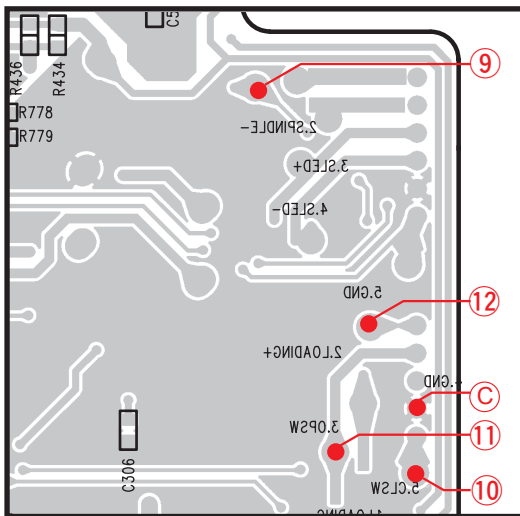

No.	Symbol	
①	TP	RFEQO
②	TP	RFO
③	TP	FEI
④	TP	FOC1
⑤	TP	TEI
⑥	TP	TRO1
⑦	TP	FMO1
⑧	TP	DMO1
⑨	CN26(3)	OPSW
⑩	CN26(5)	CLSW
⑪	CN26(2)	LOAD+
⑫	CN26(1)	LOAD-
⑬	R407	LRCK
⑭	R408	SCLK
⑮	R409	SDATA

No.	Symbol	Reference voltage
Ⓐ	TP	VC : ① ~ ⑧
Ⓑ	C900 -	DGND : ⑬ ~ ⑮
Ⓒ	CN26(4)	GND_DRV : ⑨ ~ ⑫

2. WAVEFORMS

1. DISC PLAY RF WAVEFORM (EYE-PATTERN)

CD(TCD784) PLAY

①RFEQO

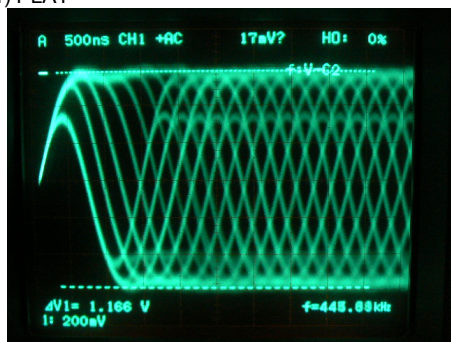

2. DISC DETECTION

CD(TCD784) DETECTION

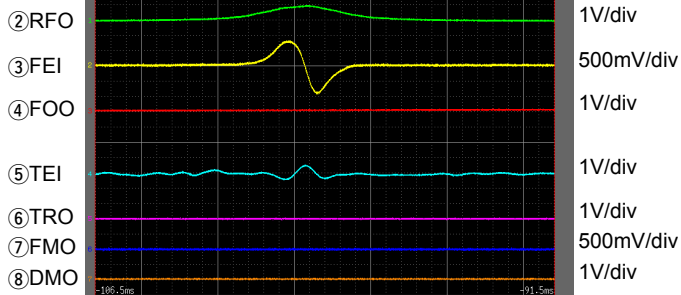

3. TOC READ

CD(TCD784) READ

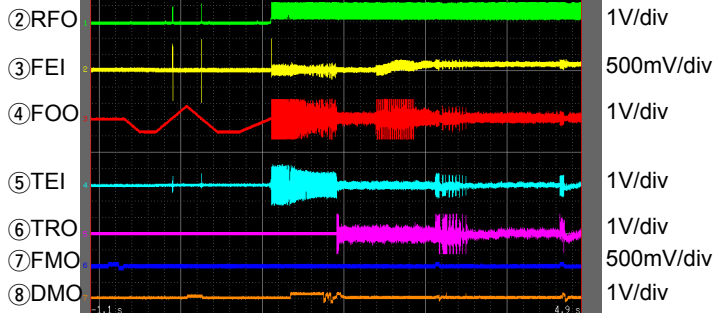

4. FOCUS ADJUSTMENT

CD(TCD784) FOCUS ADJUSTMENT

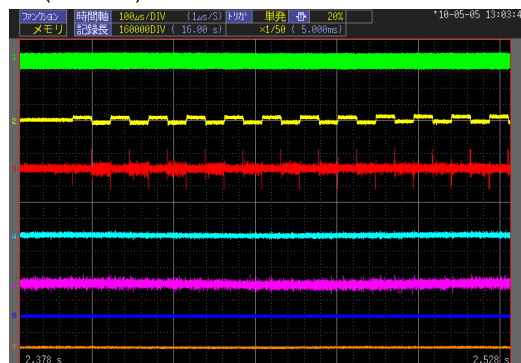

5. CD Playback

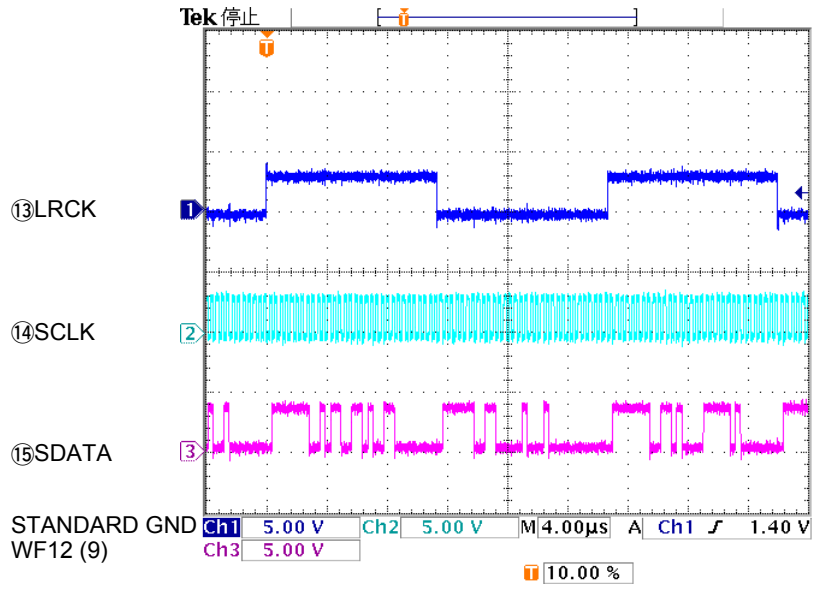

6. LOADER OPEN-CLOSE

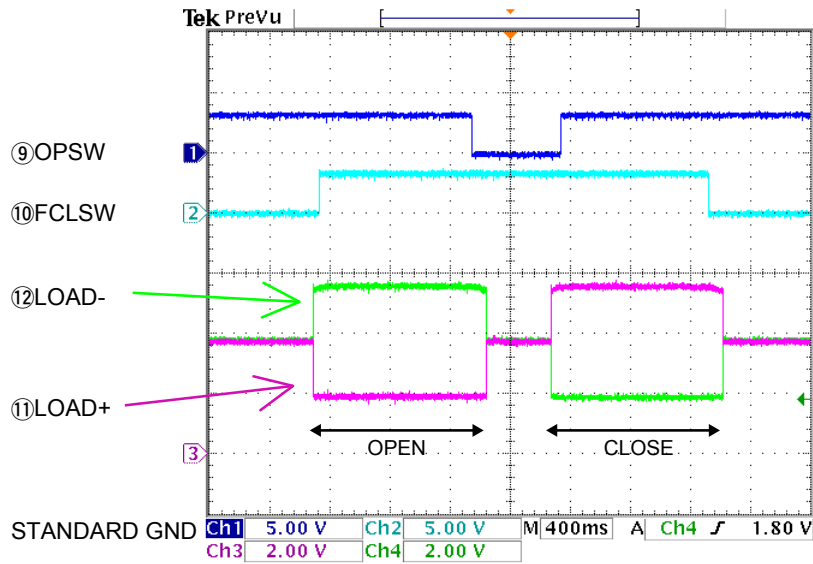

BLOCK DIAGRAM

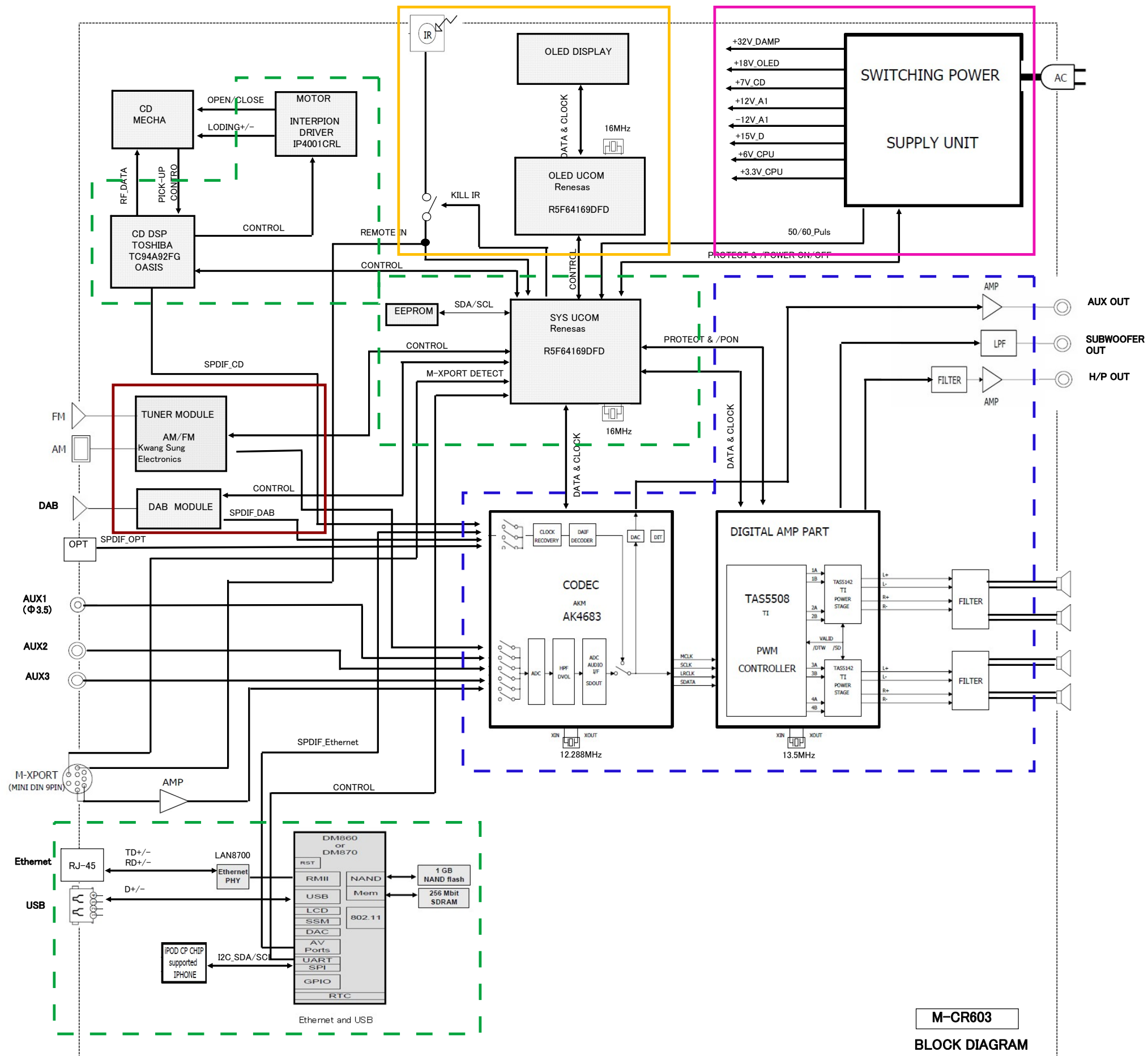

M-CR603
BLOCK DIAGRAM

POWER DIAGRAM

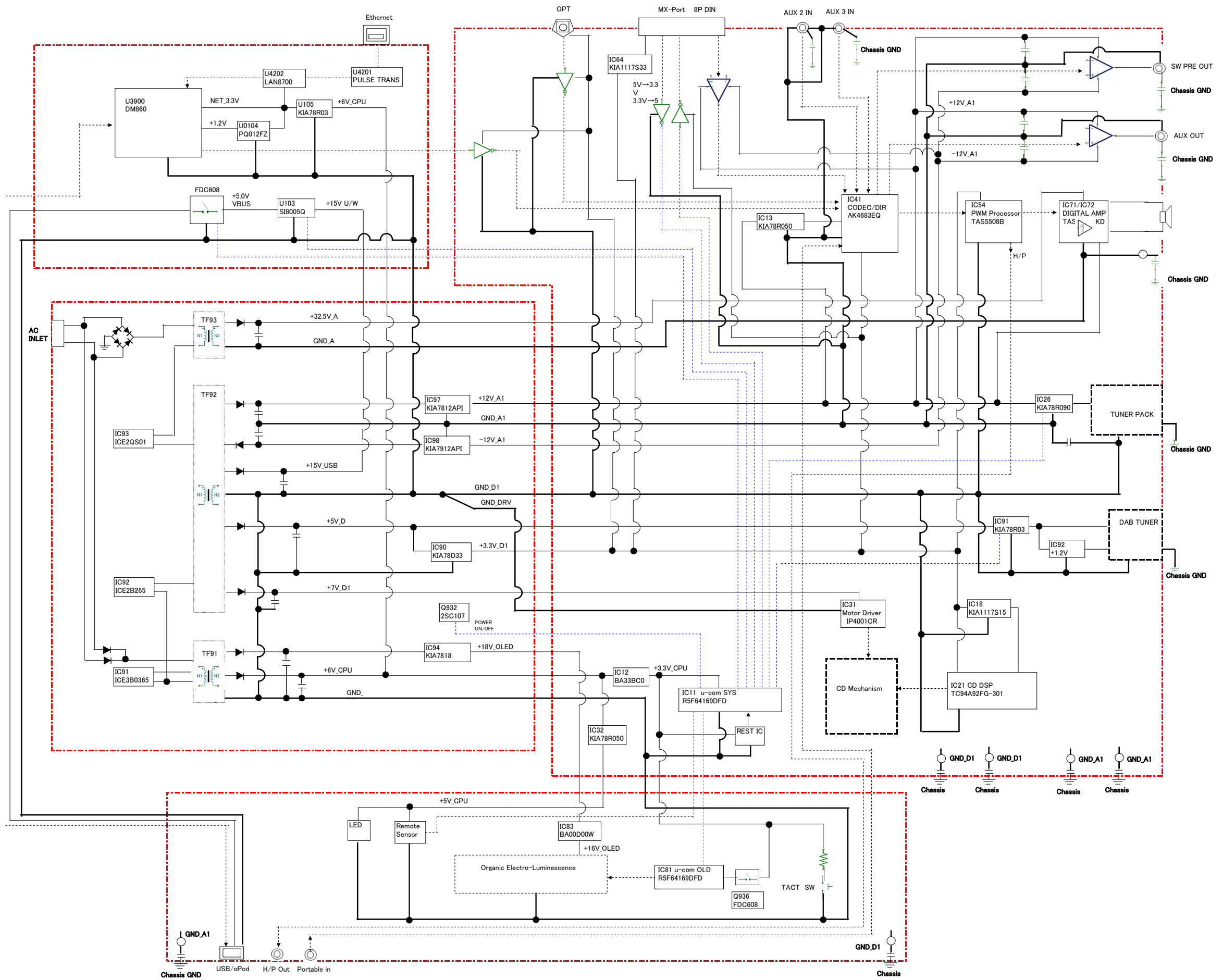

LEVEL DIAGRAM

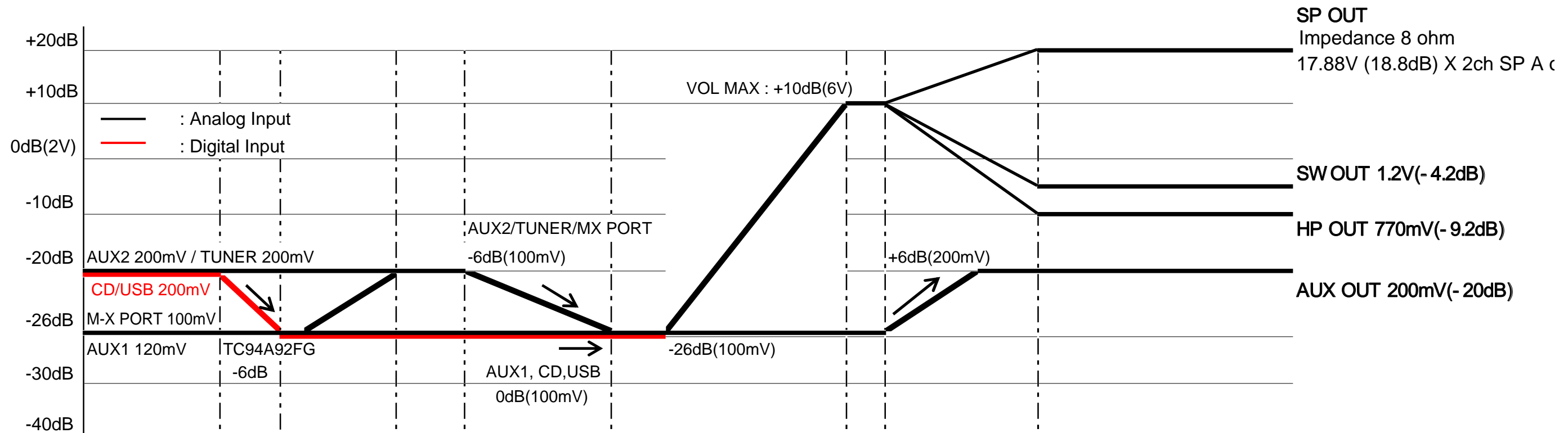
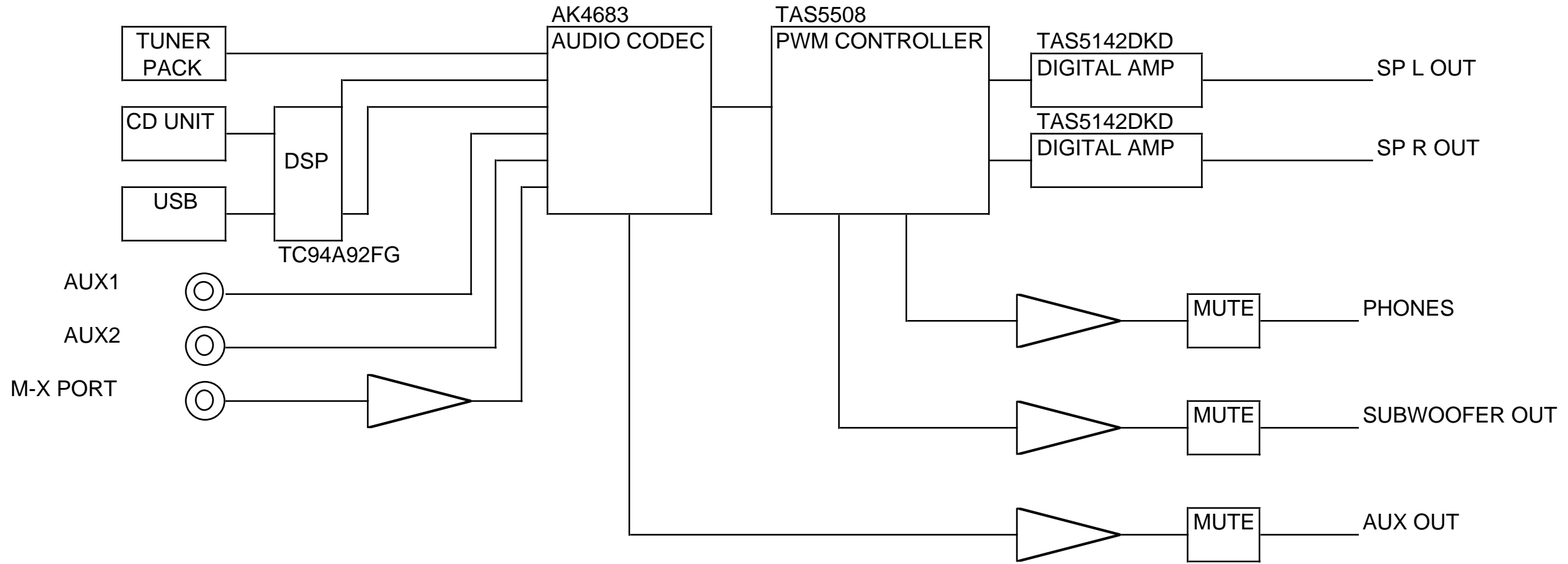

WIRING DIAGRAM

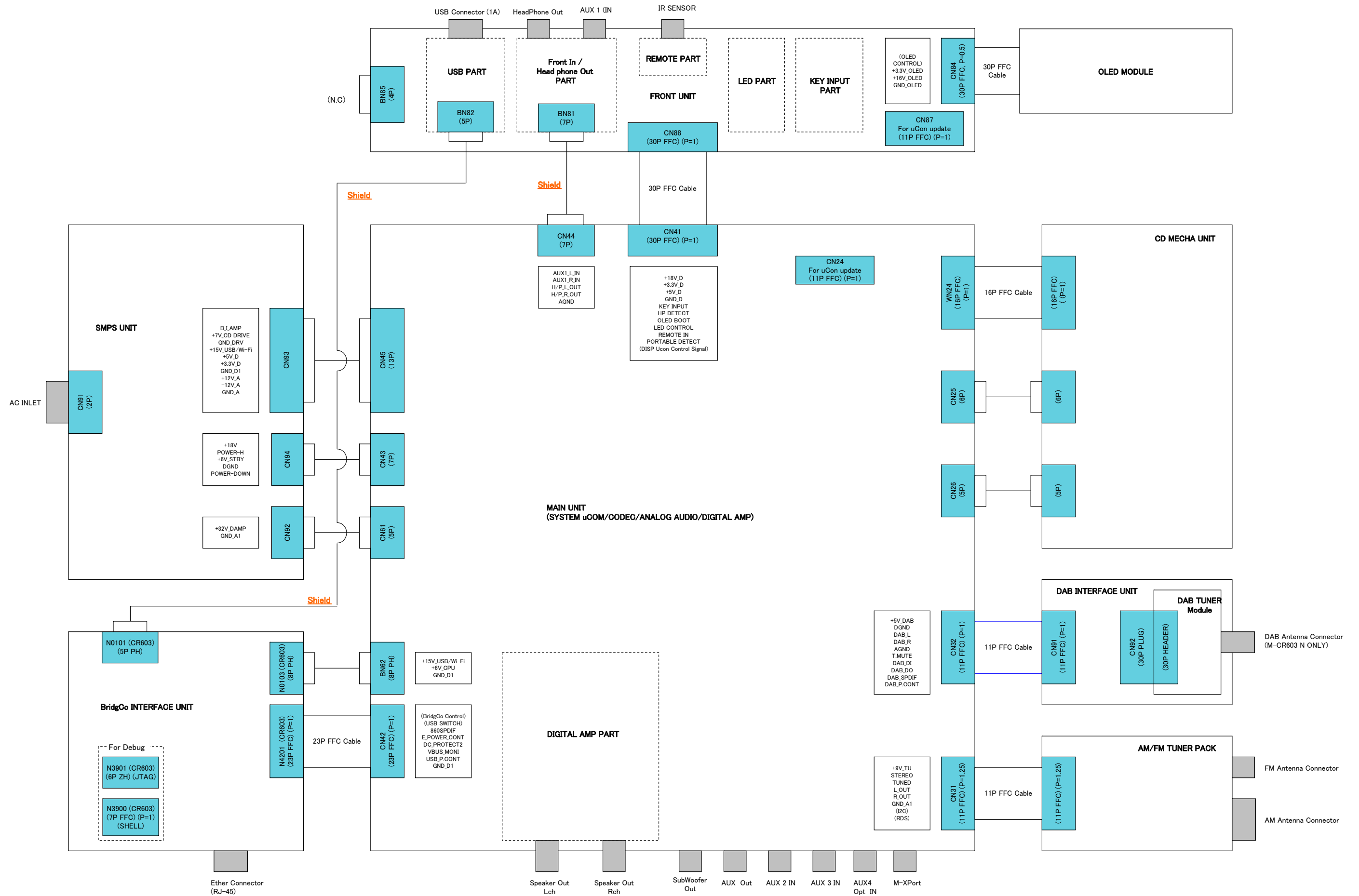

PRINTED WIRING BOARDS

1 2 3 4 5 6 7 8 9 10 11 12

A
B
C
D
E
F
G
H
I
J
K
L
M

MAIN PCB (COMPONENT SIDE)

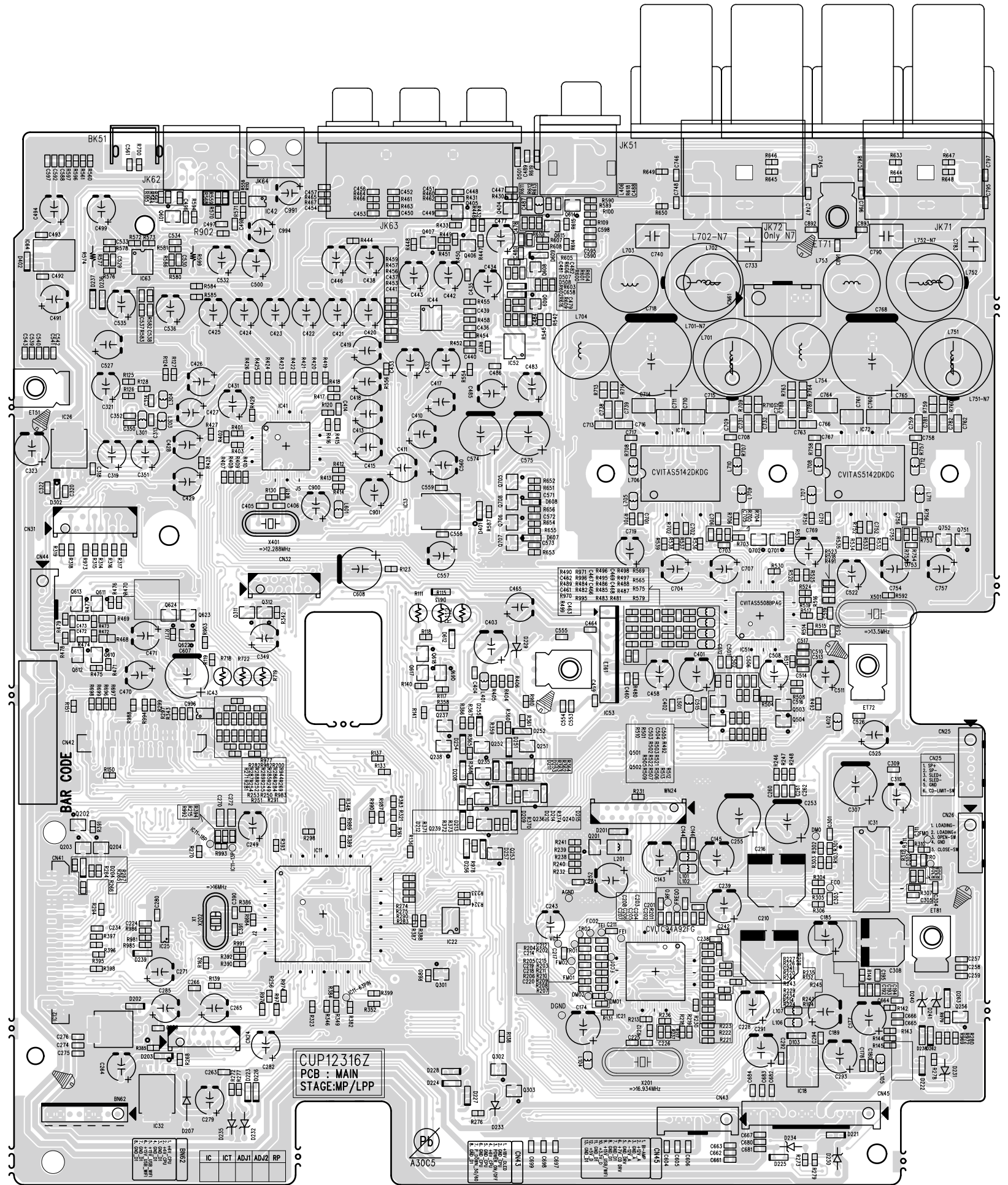

CUP12316Z
PCB : MAIN
STAGE:MP/LPP

鉛フリー半田
半田付けには、鉛フリー半田 (Sn-Ag-Cu) を使用してください。

Lead-free Solder
When soldering, use the Lead-free Solder (Sn-Ag-Cu).

12 11 10 9 8 7 6 5 4 3 2 1

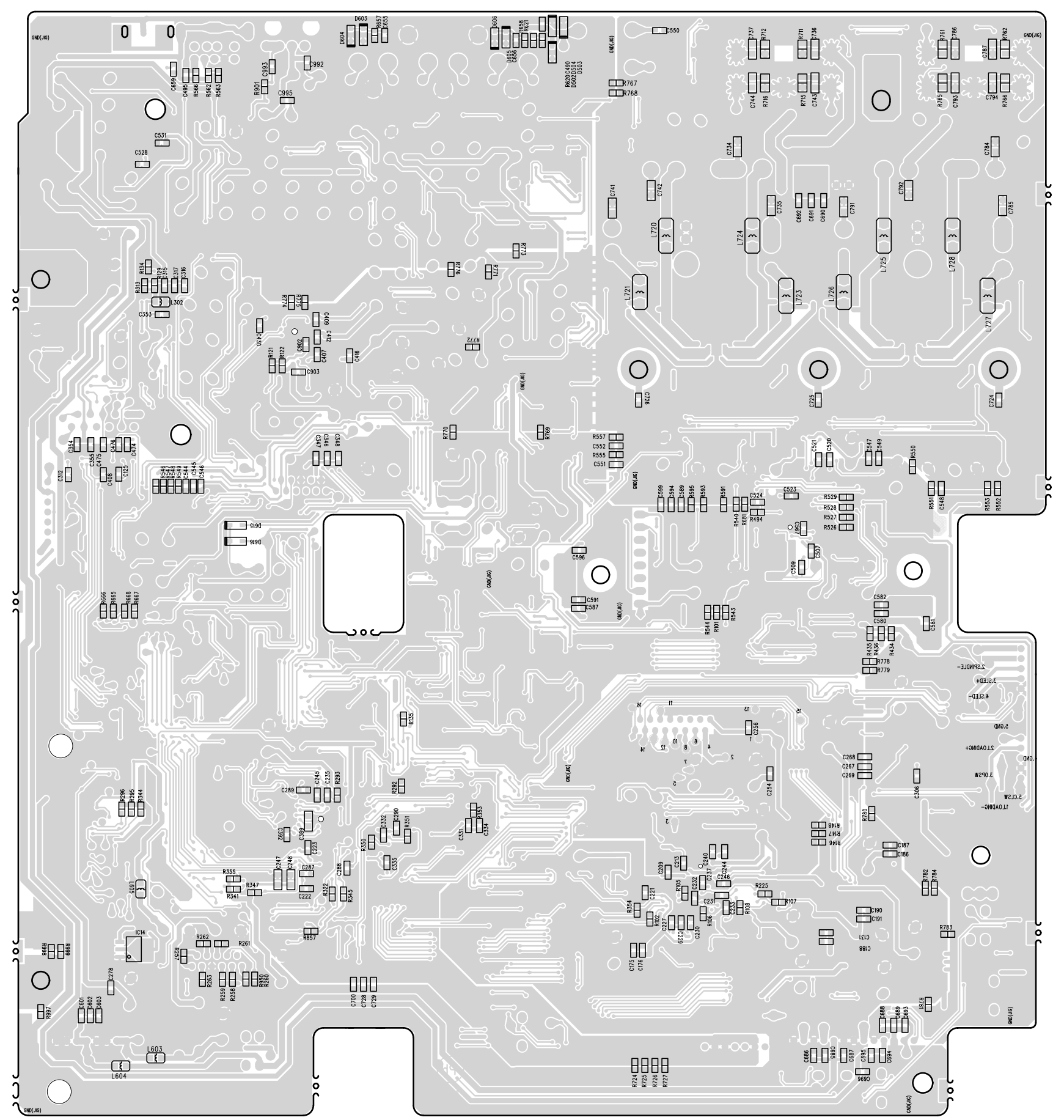

A
B
C
D
E
F
G
H
I
J
K
L
M

MAIN PCB (FOIL SIDE)

鉛フリー半田
半田付けには、鉛フリー半田 (Sn-Ag-Cu) を使用してください。

Lead-free Solder
When soldering, use the Lead-free Solder (Sn-Ag-Cu).

DISPLAY PCB (COMPONENT SIDE)

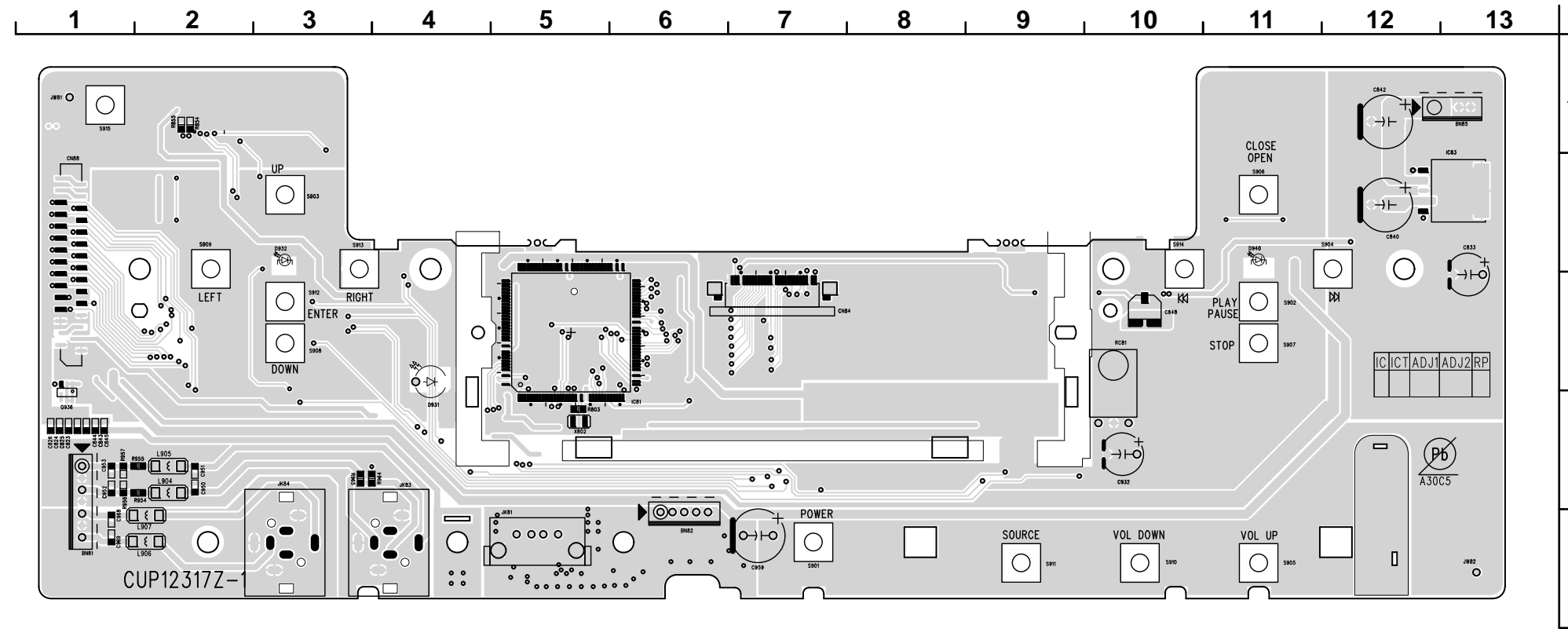

DAB PCB (COMPONENT SIDE)

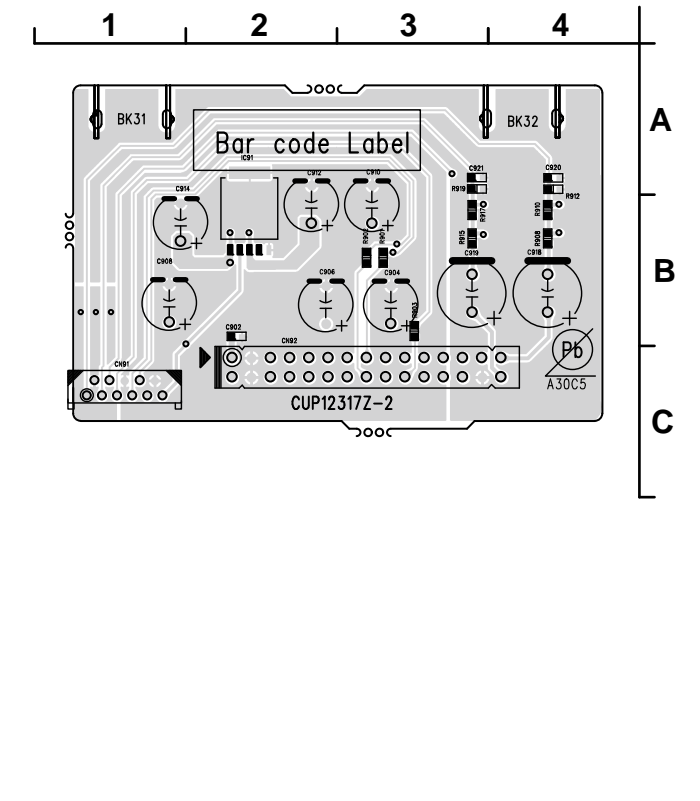

DISPLAY PCB (FOIL SIDE)

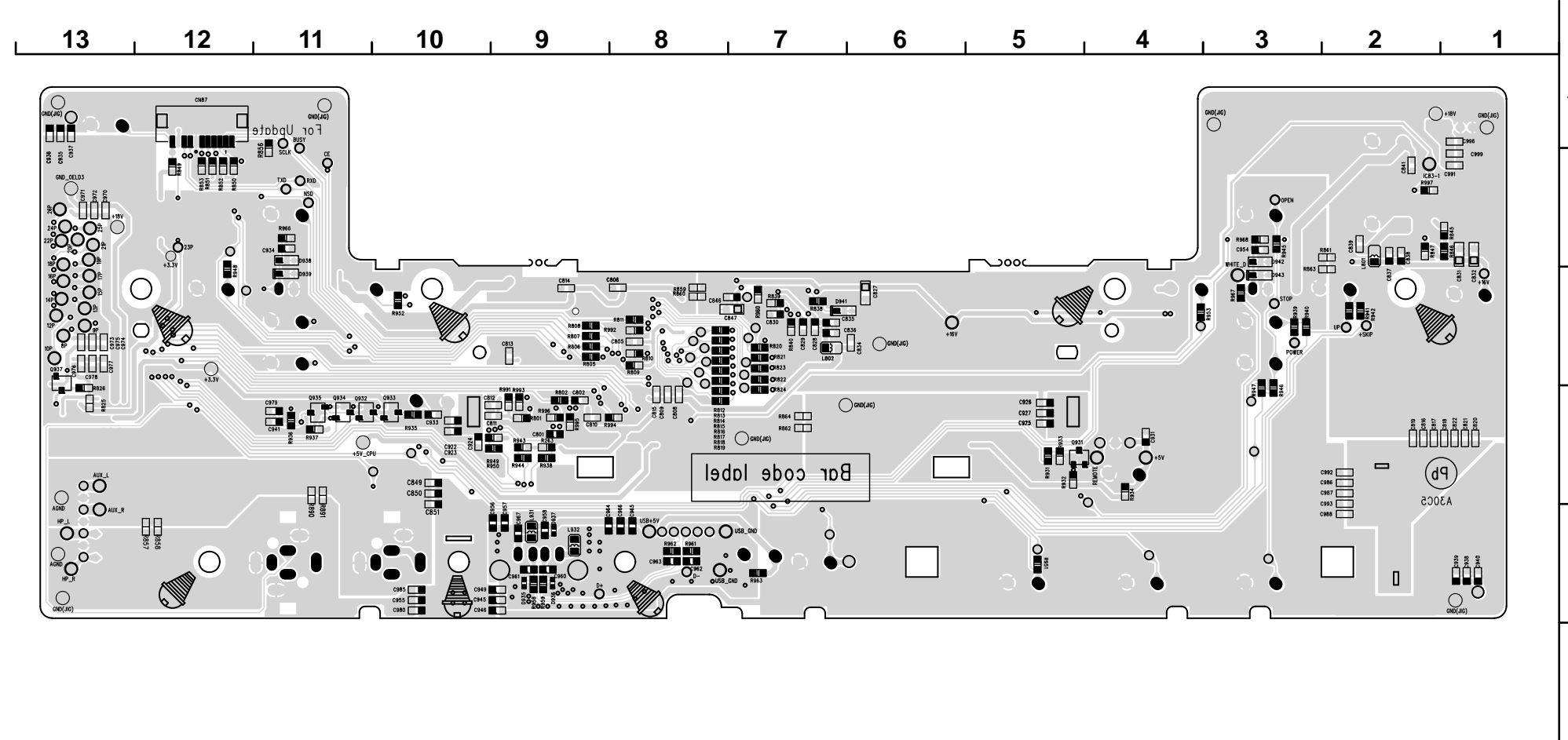

DAB PCB (FOIL SIDE)

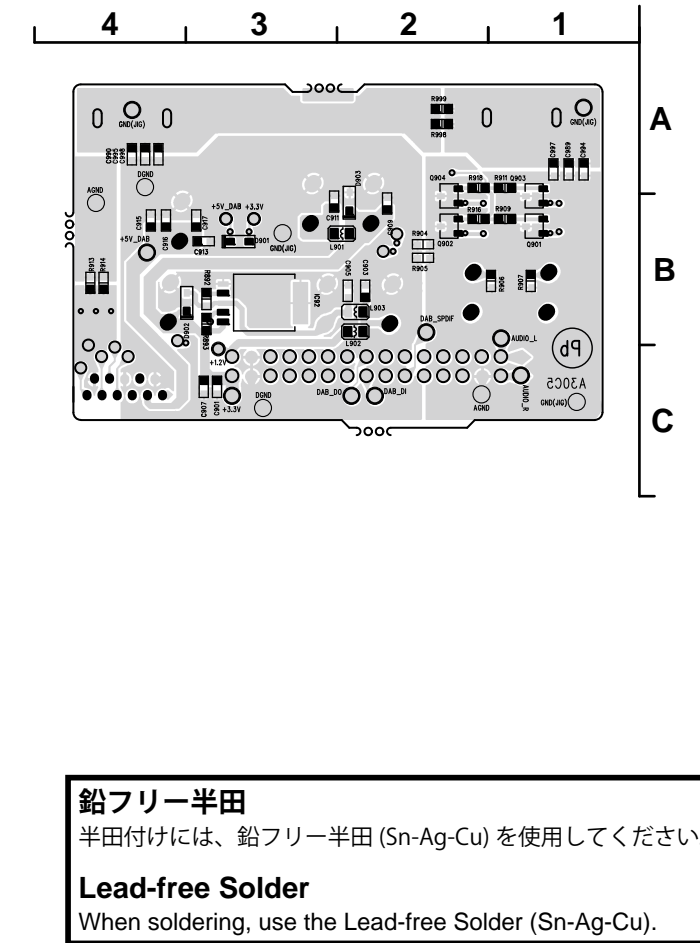

鉛フリー半田
半田付けには、鉛フリー半田 (Sn-Ag-Cu) を使用してください。
Lead-free Solder
When soldering, use the Lead-free Solder (Sn-Ag-Cu).

ETHERNET PCB (COMPONENT SIDE)

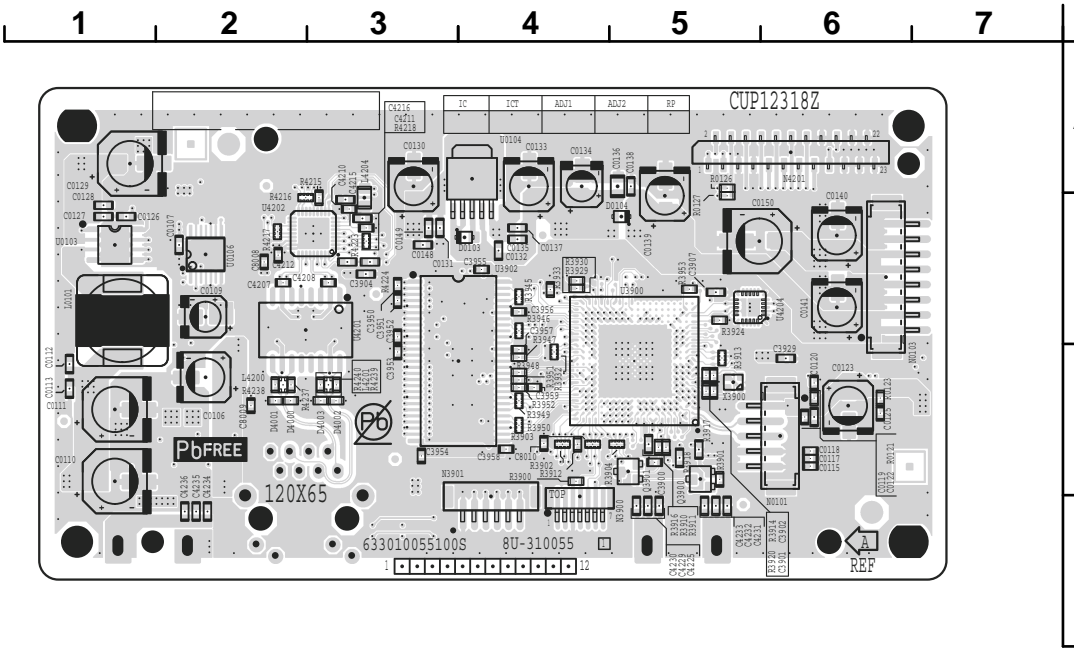

ETHERNET PCB (FOIL SIDE)

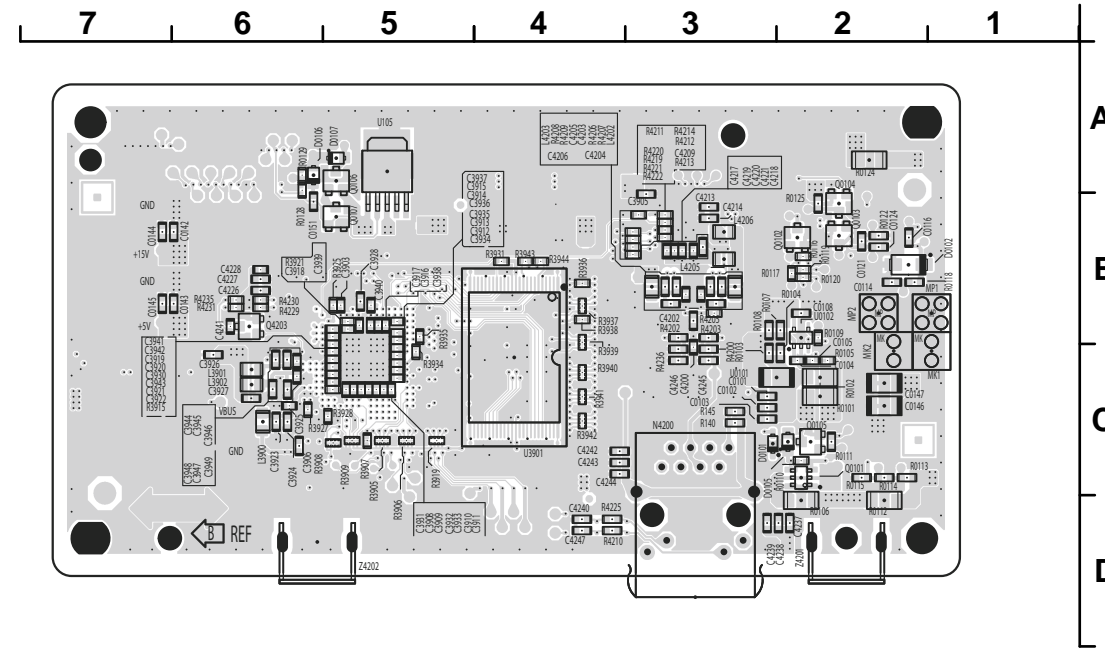

SMPS PCB (COMPONENT SIDE)

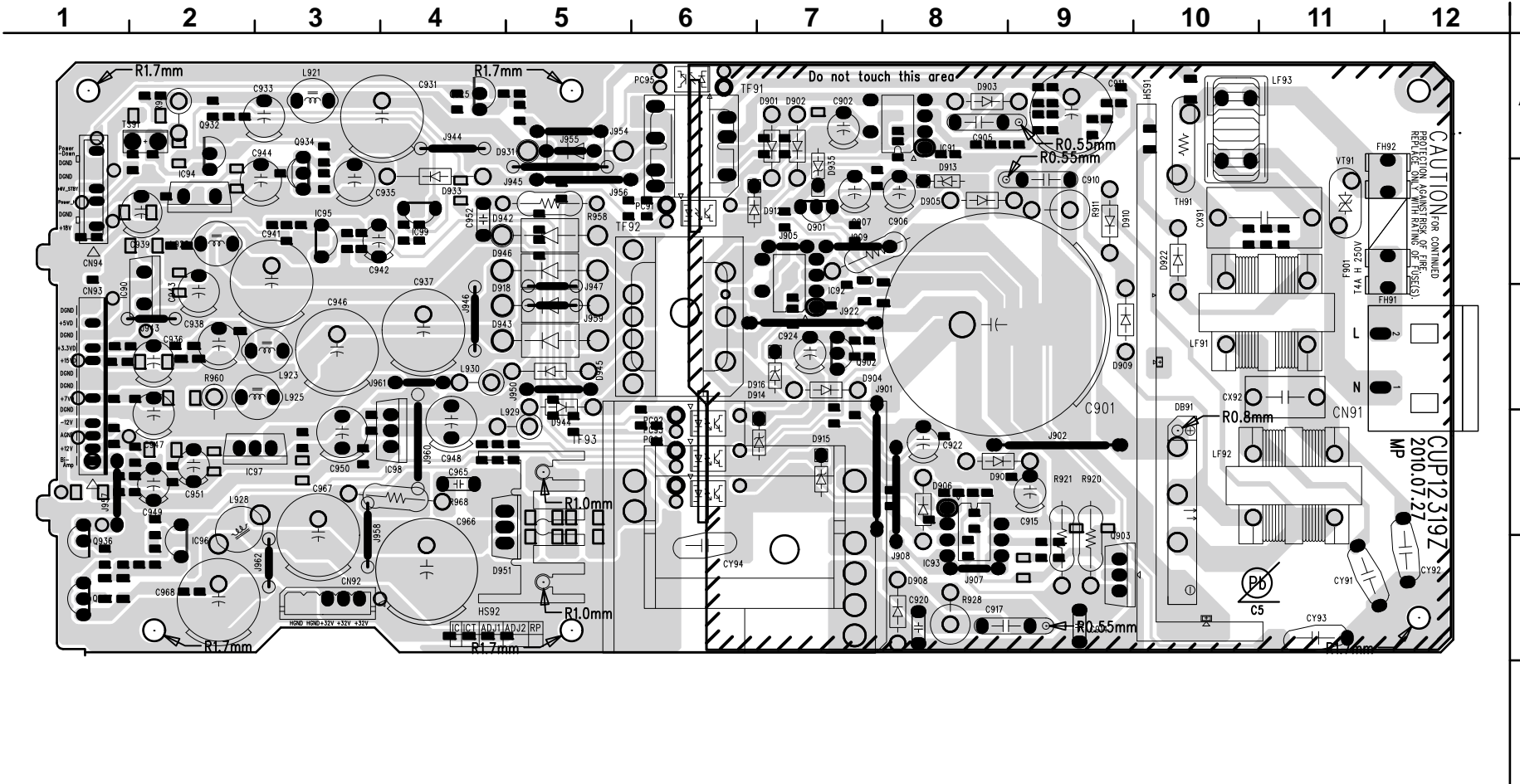

鉛フリー半田
半田付けには、鉛フリー半田 (Sn-Ag-Cu) を使用してください。

Lead-free Solder
When soldering, use the Lead-free Solder (Sn-Ag-Cu).

TUNER BLOCK SHEET 001

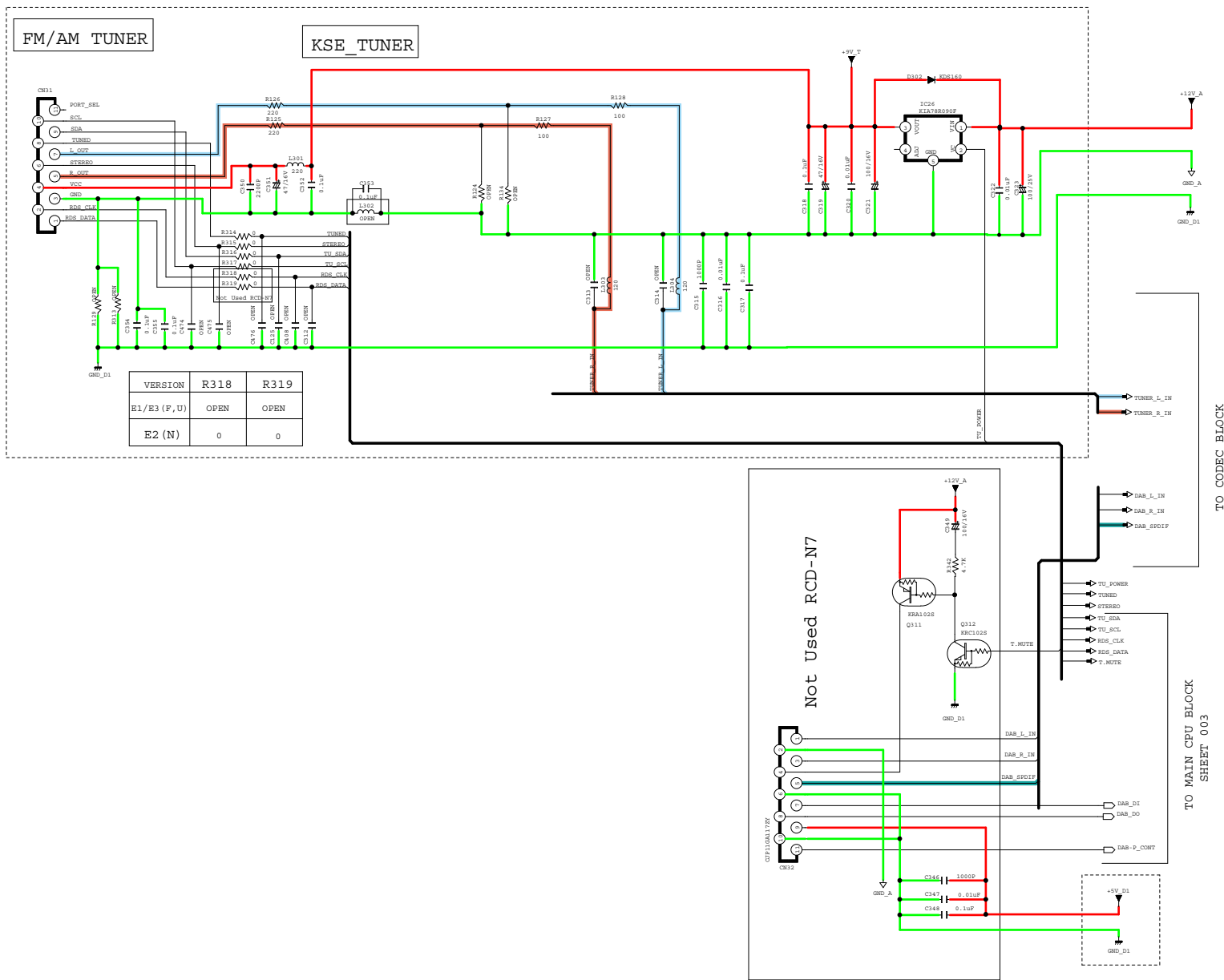

— GND
 — POWER +
 — POWER -

— ANALOG L SIGNAL LINE
— ANALOG R SIGNAL LINE
— DIGITAL SIGNAL LINE
— SW SIGNAL LINE

SCHMATIC DIAGRAMS (1/9)

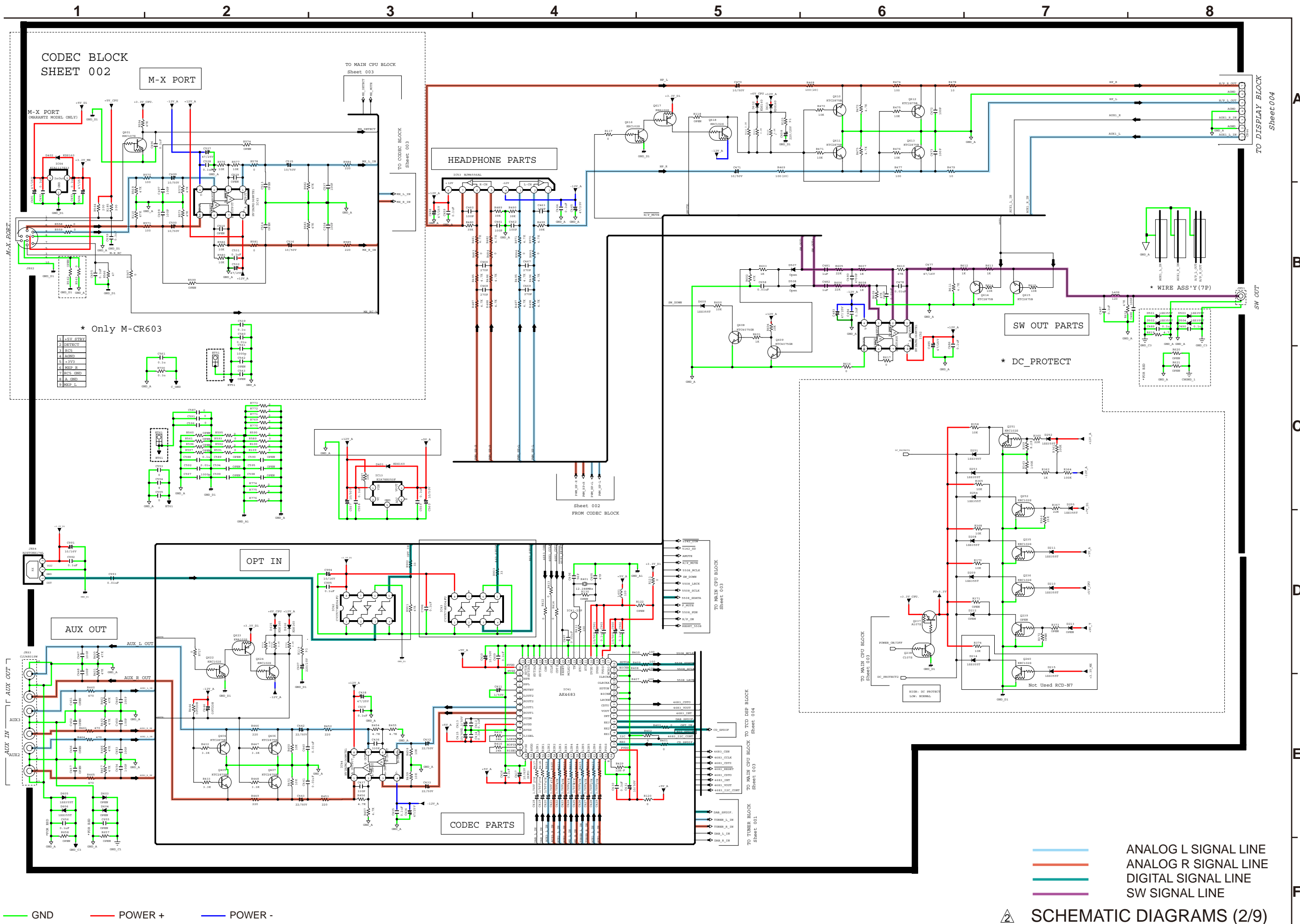

MAIN CPU BLOCK
SHEET 003

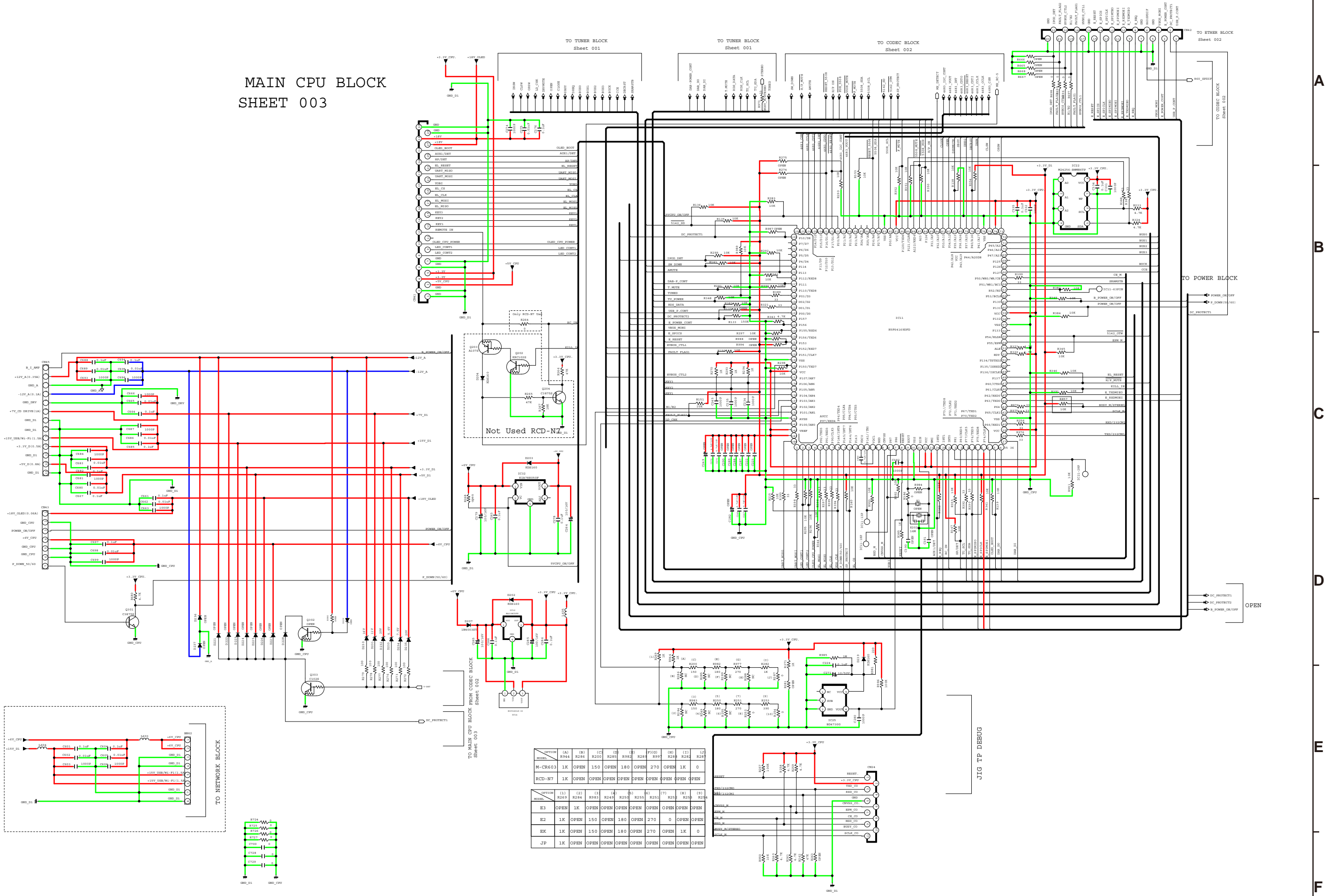

REF	VALUE	(A)	(B)	(C)	(D)	(E)	(F)	(G)	(H)	(I)	(J)	(K)
M-CR603	1K	OPEN	150	OPEN	180	OPEN	270	OPEN	1K	0		
RCD-N7	1K	OPEN	OPEN	OPEN	DPEN	OPEN	OPEN	OPEN	OPEN	OPEN		
E3	OPEN	1K	OPEN	OPEN	OPEN	OPEN	OPEN	OPEN	OPEN	OPEN		
E2	1K	OPEN	150	OPEN	180	OPEN	270	0	OPEN	OPEN		
EK	1K	OPEN	150	OPEN	180	OPEN	270	OPEN	1K	0		
JP	1K	OPEN	OPEN	OPEN	OPEN	OPEN	OPEN	OPEN	OPEN	OPEN		

— GND — POWER + — POWER -

CD DSP BLOCK
SHEET 004

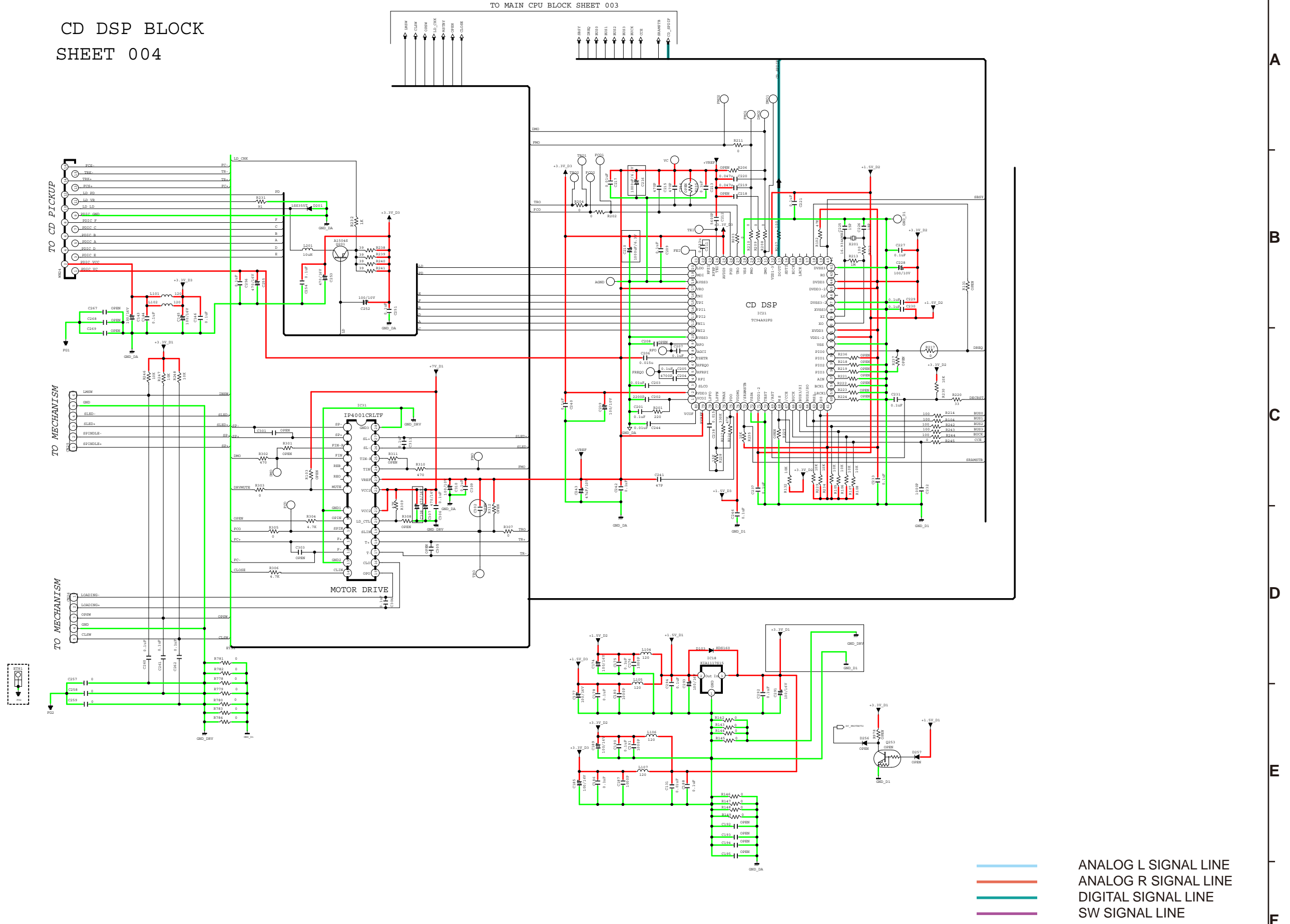

— GND — POWER + — POWER -

— ANALOG L SIGNAL LINE
— ANALOG R SIGNAL LINE
— DIGITAL SIGNAL LINE
— SW SIGNAL LINE

△ SCHEMATIC DIAGRAMS (4/9)

PWM/AMP BLOCK
SHEET 005

PWM CONTROLLER
PARTS

AMP PARTS

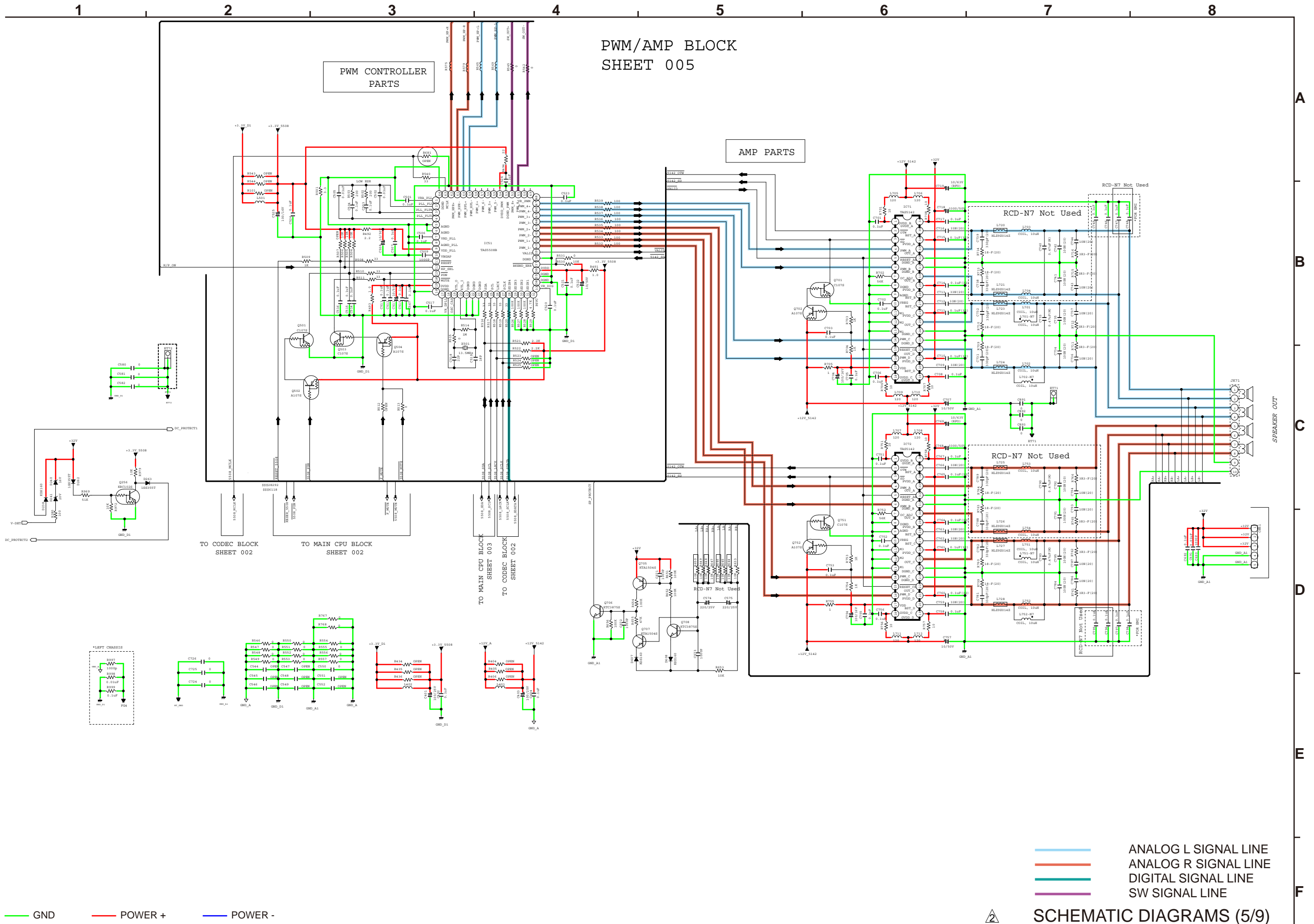

ANALOG L SIGNAL LINE
ANALOG R SIGNAL LINE
DIGITAL SIGNAL LINE
SW SIGNAL LINE

SCHMATIC DIAGRAMS (5/9)

GND POWER + POWER -

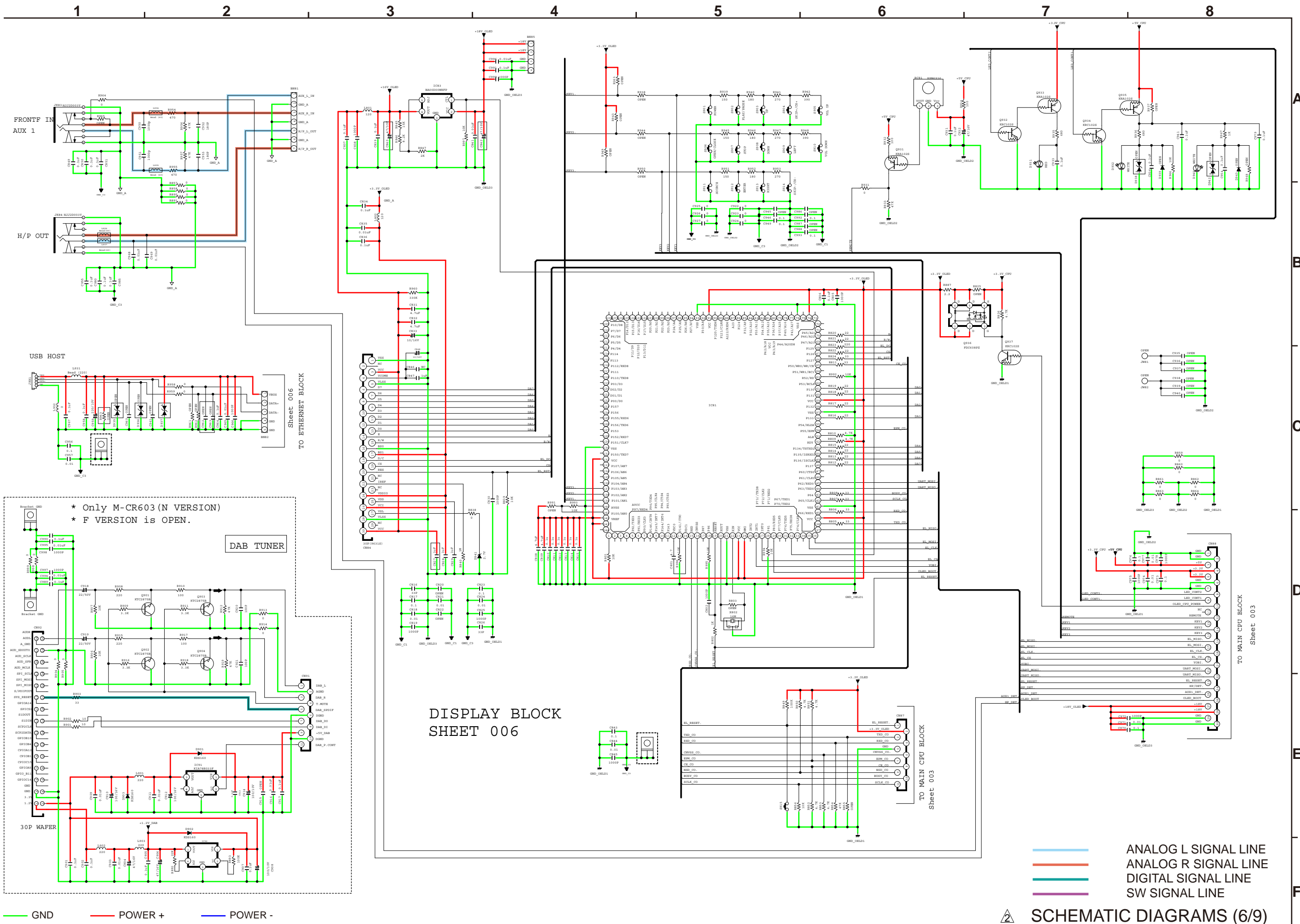

— GND
— POWER +
— POWER -

— ANALOG L SIGNAL LINE
— ANALOG R SIGNAL LINE
— DIGITAL SIGNAL LINE
— SW SIGNAL LINE
 SCHEMATIC DIAGRAMS (6/9)

SMPS SCHEMATIC DIAGRAM

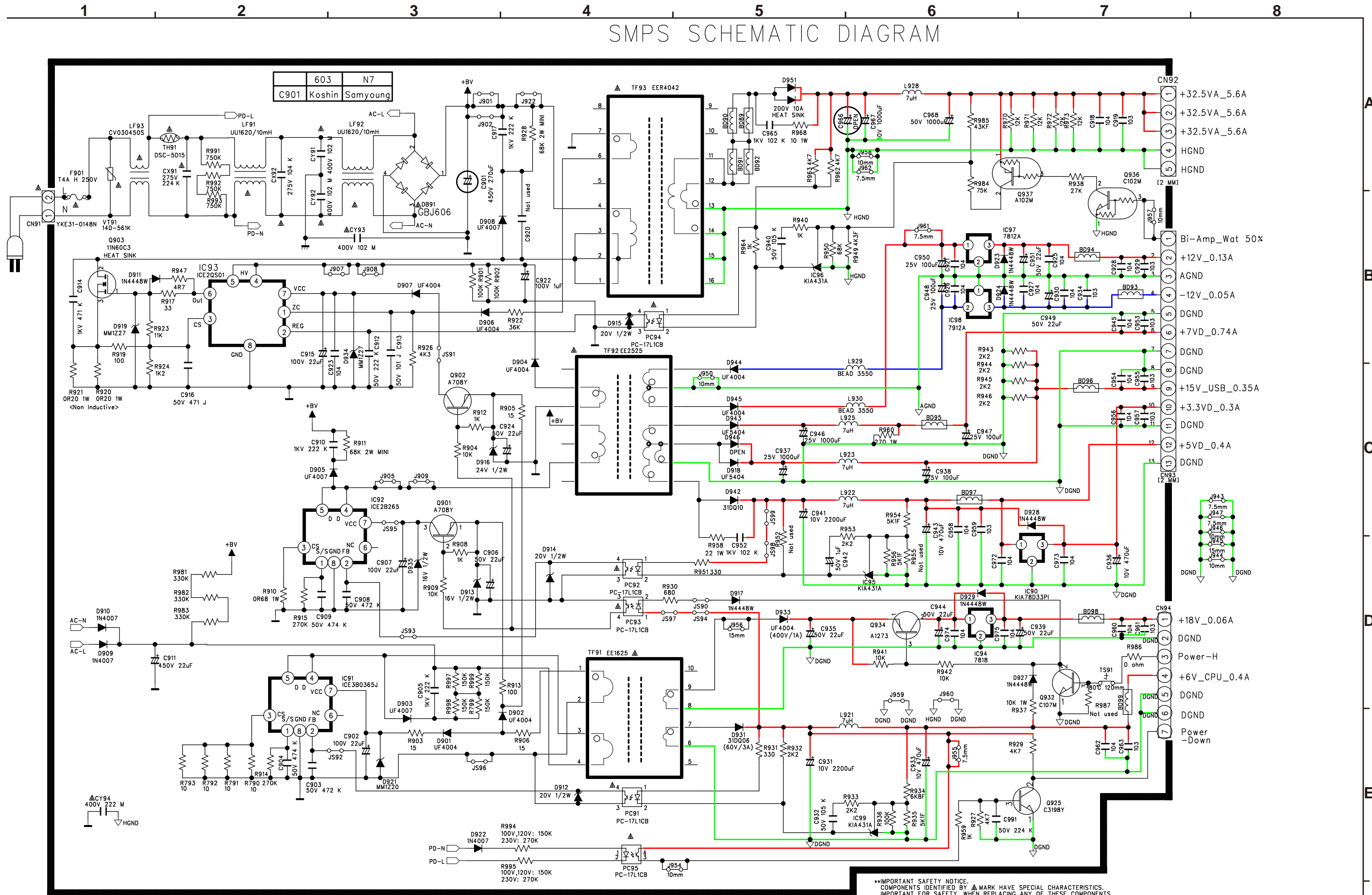

***IMPORTANT SAFETY NOTICE:
COMPONENTS IDENTIFIED BY MARK HAVE SPECIAL CHARACTERISTICS.
IMPORTANT FOR SAFETY, WHEN REPLACING ANY OF THESE COMPONENTS,
USE ONLY MANUFACTURER'S SPECIFIED PARTS.
*THE UNIT OF RESISTANCE IS OHM.
K=1000 OHM, M=1000 KOHM
*THE UNIT OF CAPACITANCE IS MICROFARAD (uF)
pF=10^-6 uF
*THIS SCHEMATIC DIAGRAM MAY MODIFIED AT ANY TIME WITH THE
IMPROVEMENT OF PERFORMANCE

— GND — POWER + — POWER -

SCHEMATIC DIAGRAMS (7/9)

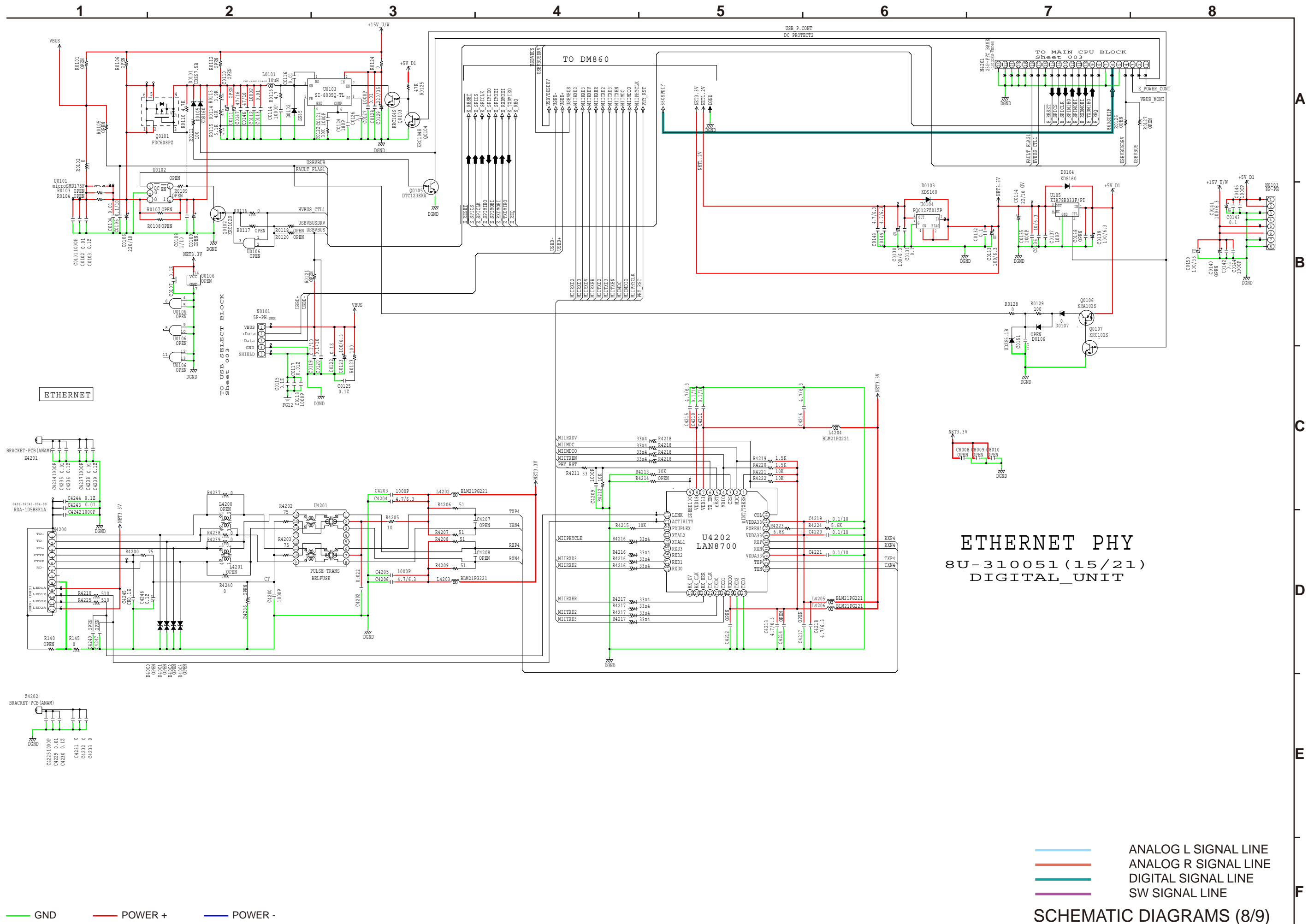

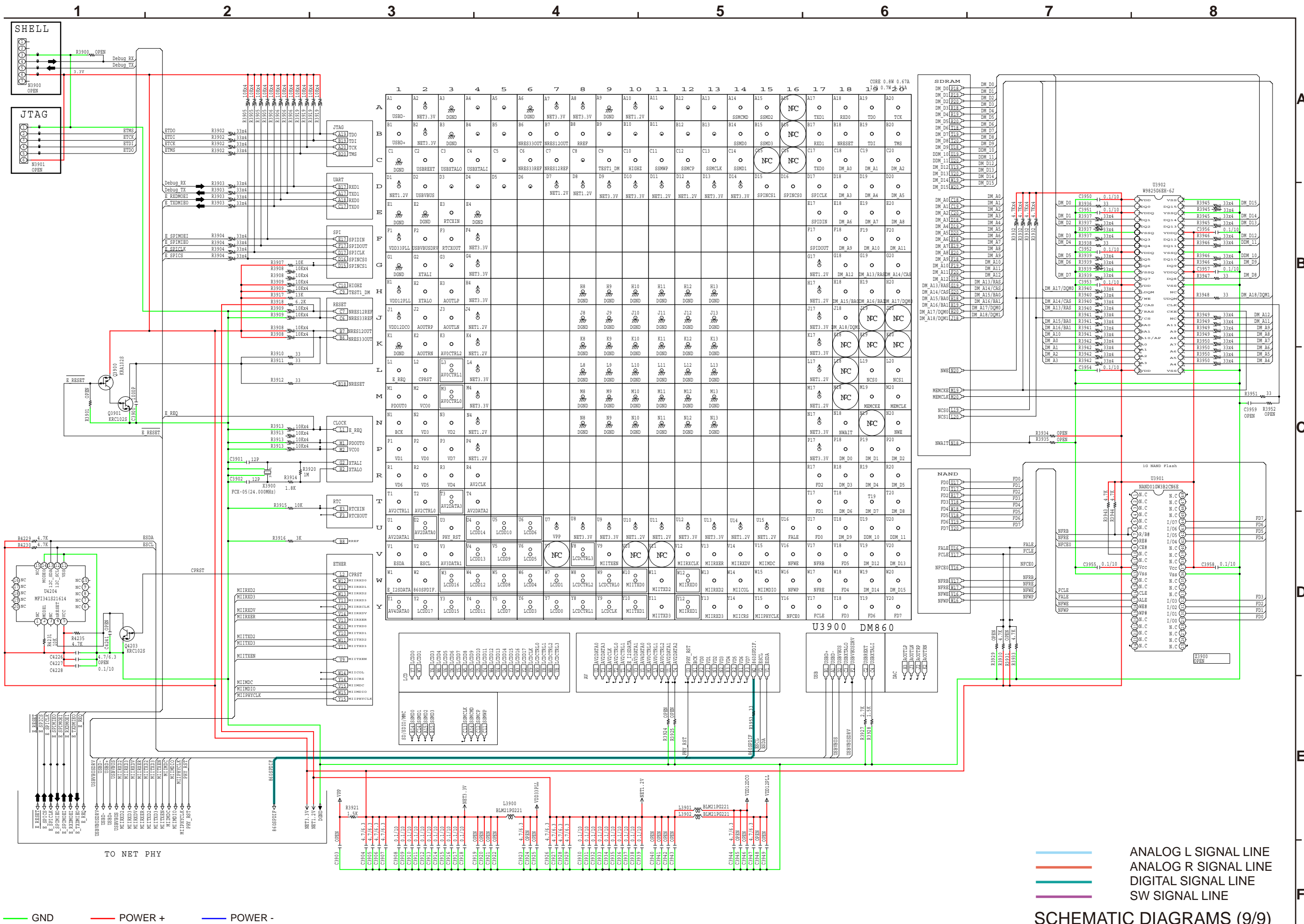

EXPLODED VIEW

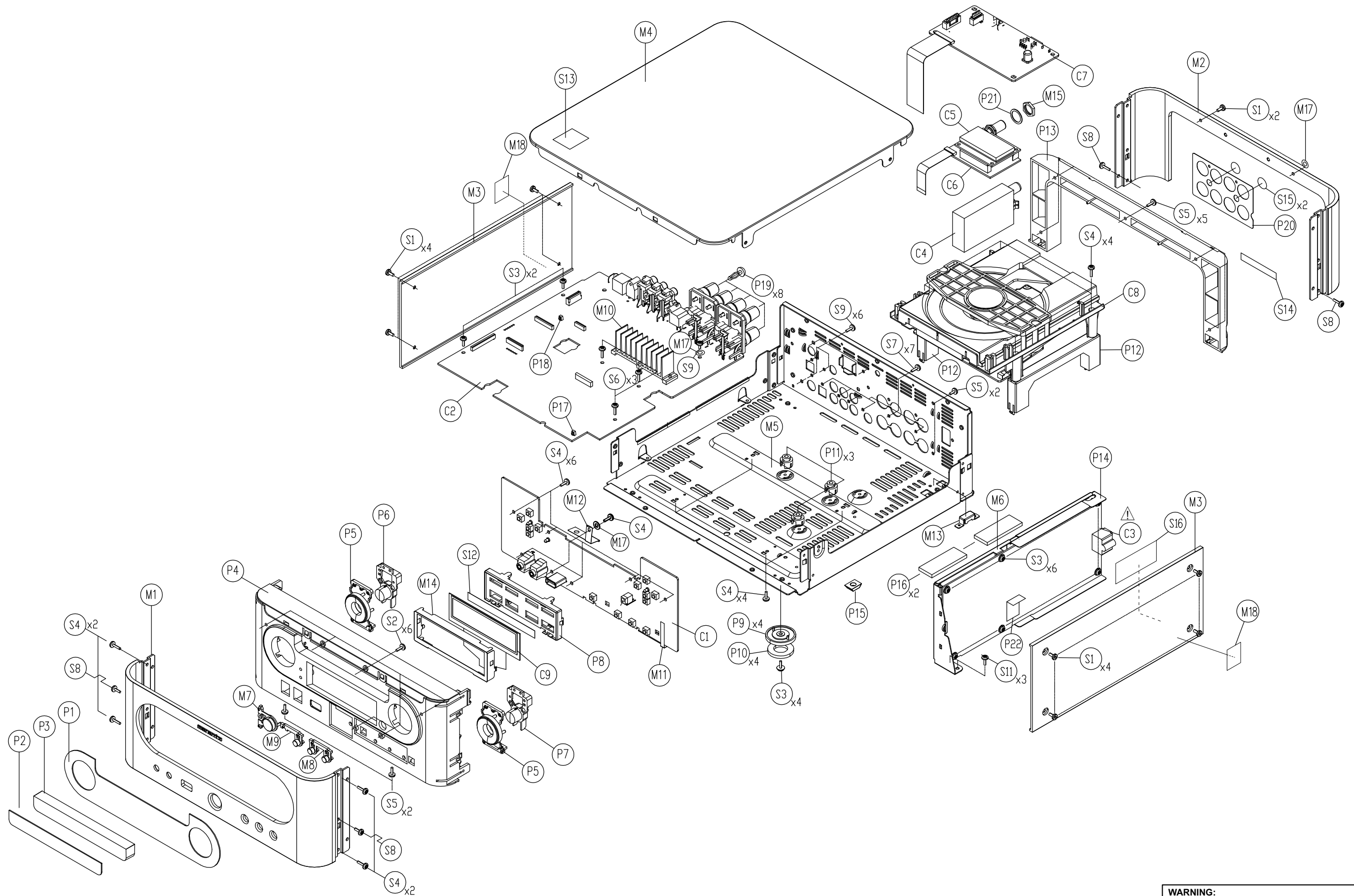

WARNING:
 Parts marked with this symbol have critical characteristics.
 Use ONLY replacement parts recommended by the manufacturer.

PARTS LIST OF EXPLODED VIEW

*Parts for which "nsp" is indicated on this table cannot be supplied.

*P.W.B. ASS'Y for which "nsp" is indicated on this table cannot be supplied. When repairing the P.W.B. ASS'Y, check the board parts table and order replacement parts.

*Part indicated with the mark "★" is not illustrated in the exploded view.

*The parts listed below are for maintenance only, might differ from the parts used in the unit in appearances or dimensions.

Ref. No.	Part No.	Part Name	Remarks	Q'ty	New	
	C1	nsp	M-CR603/NISG DISPLAY PCB ASS'Y	COP12317B	1	*
	C2	nsp	M-CR603/NISG MAIN PCB ASS'Y	COP12316B	1	*
	C3	nsp	M-CR603/NISG SMPS PCB ASS'Y	COP12319B	1	*
	C4	943183009250S	MODULE , TUNER (EUR)	CNVMT104MS1-80A	1	
	C5	943189012720M	MODULE DAB (DAB7.0)	CNVFS2027B0291	1	*
	C6	nsp	DAB PCB ASS'Y	COP12317B	1	*
	C7	8U-310055S	M-CR603/NISG ETHERNET PCB ASS'Y	COP12318B	1	*
	C8	943302009630S	MECHANISM ASS'Y (CJDL2130BZ)	CJDMCR503ZA	1	
	C9	943179011170S	OLED MODULE	CFLMXS4003-A	1	*
	M1	943402011120M	FRONT ASS'Y	N1SG CKMMCR603	1	*
	M1	402410176001S	FRONT ASS'Y	N1B,U1B CKMMCR603BLACK	1	*
	M2	406410040036M	PANEL , REAR M-CR502/N1SG	N1SG CKM1A198C62	1	
	M2	406410109003S	PANEL , REAR	N1B,U1B CKM1A198C32	1	
	M3	404410003031M	PANEL , SIDE M-CR502/N1SG	N1SG CKM1A199C62	2	
	M3	404410036000S	PANEL , SIDE	N1B,U1B CKM1A199C23	2	
	M4	943403011180S	COVER, TOP(EUR)	CKC1A185ZS61	1	*
	M5	nsp	CHASSIS, BOTTOM	N1SG,N1B CUA4A287Z	1	*
	M5	nsp	CHASSIS, BOTTOM(U)	U1B CUA6A287Y	1	*
	M6	nsp	COVER , SHIELD	CMD1A678	1	
	M7	411010039032M	BUTTON , POWER	N1SG CGK1A135ZA	1	
	M7	411010126004S	BUTTON , POWER	N1B,U1B CGK1A135YA	1	
	M8	411010040032M	BUTTON , VOLUME	N1SG CGK1A136ZA	1	
	M8	411010128000S	BUTTON , VOLUME	N1B,U1B CGK1A136XA	1	
	M9	943411011190S	BUTTON, VOLUME	N1SG CGK1A136YA	1	*
	M9	411010127007S	BUTTON , VOLUME	N1B,U1B CGK1A136WA	1	*
	M10	nsp	HEAT SINK	CMY1A304	1	
	M11	nsp	PLATE, EARTH A	CMC1A407	1	*
	M12	nsp	PLATE, EARTH B	CMC1A408	1	*
	M13	nsp	COVER , SCREW	CMD1A495	1	
	M14	nsp	COVER, SHIED OLED	CMC1A405	1	*
	M15	nsp	NUT, DAB			
	M17	nsp	WASHER , GROUND	CNW1A035	2	
	M18	nsp	LABEL , DENERGIOUS MARK	U1B CQB1A1052Z	2	
	P1	943416011220S	WINDOW, OLED	CGU1A452Z	1	*
	P2	943416011350S	WINDOW, DOOR	CGU1A420X	1	*
	P3	418510006007M	DOOR , CD	CGR1A451	1	
	P4	nsp	PANEL, SUB	CGW1A502	1	*
	P5	943411011230S	FUNCTION BUTTON ASS'Y	CBT1A1076YA	2	*
	P6	411510038003M	BUTTON , ENTER	CBT1A1077ZK92	1	
	P7	411510038010M	BUTTON , PLAY	CBT1A1089ZK92	1	
	P8	nsp	HOLDER, OLED	CMH1A309	1	*
	P9	407010002000M	FOOT	CKL1A102	4	
	P10	943407002950M	RUBBER ,FOOT	CHG1A297	4	
	P11	nsp	HOLDER , PCB	CHE170	3	
	P12	nsp	SUPPORT , MECHA	CMH1A289	2	
	P13	nsp	SUPPORT , REAR CR502/N	CMH1A288	1	
	P14	nsp	INSULATOR	CMX1A284	1	
	P15	nsp	RUBBER	CHG1A113	1	
	P16	nsp	CUSHION , SUPPORT	CHG1A305	2	
	P17	nsp	SUPPROT, PCB(MC-5)	CRE1A097	1	
	P18	nsp	SUPPORT, PCB(MC-10)	CRE1A098	1	
	P19	nsp	LOCKER	CRE1A037	8	
	P20	nsp	SHEET, PROTECTION	CGX1A454Z	1	
	★ P21	nsp	PLATE, EARTH C	CMC1A413	1	*
	★ P22	nsp	PLATE, EARTH D	CMC1A415	2	*
	S12	nsp	TAPE , BOTH SIDE	C4FA101	-	
	S13	nsp	LABEL , WINDOW7	CQB1A1011Z	1	*
	S14	nsp	SHIPPING LABEL	CQB2A323Z	2	

Ref. No.	Part No.	Part Name	Remarks		Q'ty	New
S15	nsp	SHEET, COVER		CHS1A154	2	
S16	nsp	SHEET		CMX1A180Z	1	*
SCREWS						
S1	nsp	SCREW , SPECIAL	N1SG	CHD1A063	10	
S1	nsp	SCREW , SPECIAL	N1B,U1B	CHD1A063ZR	10	
S2	nsp	SCREW		CTB26+8JFZR	6	
S3	nsp	SCREW		CTW3+8JR	12	
S4	nsp	SCREW		CTB3+10JR	19	
S5	nsp	SCREW		CTB3+8JFZR	12	
S6	nsp	SCREW		CTW3+12JR	3	
S7	nsp	SCREW		CTB3+10JFZR	5	
S8	nsp	SCREW		CTB3+8JR	2	
S9	nsp	SCREW		CTB3+6FFZR	7	
S10	nsp	SCREW		CTB3+6JR	3	
S11	nsp	SCREW		CTB3+6JR	3	
WIRES						
★ 101	943606010880S	CABLE , CARD(16P, 180mm CD MECHA)		CWC4F1A16A180A08	1	*
★ 102	943606011320S	CABLE , CARD(1.0MM, 11P, 100MM, B TYPE)		CWC4F4A11A100B08	1	*
★ 103	943606011340S	CABLE , CARD(1.25MM, 11P, 80MM, B TYPE)		CWC4F4A11B080B08	1	*
★ 104	943606011330S	CABLE , CARD(1.0MM, 23P, 150MM, B TYPE)		CWC4F4A23A150B08	1	*
★ 105	943606011480S	CABLE , CARD(1.0MM, 30P, 180MM, B TYPE)		CWC4F4A30A180B08	1	*

PACKING VIEW

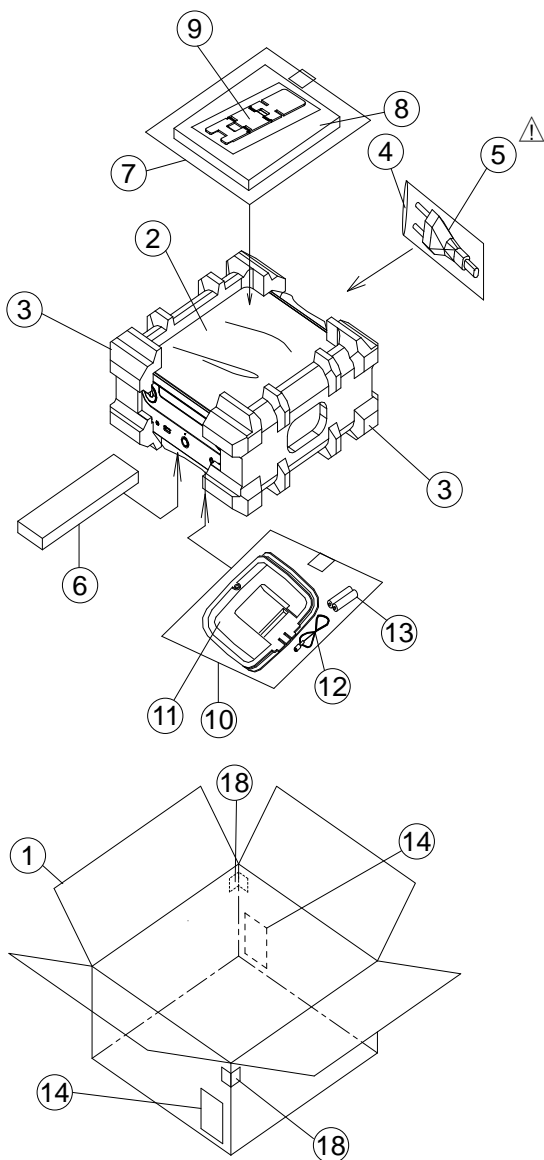

PARTS LIST OF PACKING & ACCESSORIES



*Parts for which "nsp" is indicated on this table cannot be supplied.

*The parts listed below are for maintenance only, might differ from the parts used in the unit in appearances or dimensions.

*Part indicated with the mark "★" is not illustrated in the exploded view.

Ref. No.	Part No.	Part Name	Remarks	Q'ty	New	
	1	531210163004M	BOX, OUT CARTON	CPG1A867V	1	*
	2	943535006230S	BAG , POLY(SET)	CPB1A184Z	1	
	3	533610022006M	PAD , SNOW	CPS1A822	2	
	4	nsp	BAG , POLY	CPB1A008Z	1	
⚠	5	943611000190S	CORD , POWER EUR(H03VVH2-F 2X0.75MM NM)	N1SG,N1B	1	
⚠	5	943611000230S	POWER CORD UL CJA2A107ZV	U1B	1	
	6	307010079001M	REMOCON TRANSMITER ASS'Y (M-CR603)	CARTMCR603	1	*
	7	943535001070D	BAG , POLY(ENGLISH/FRANCH)	CPB1061W	1	
	8	541110506005M	MANUAL, INSTRUCTION(E2)	N1SG,N1B	1	*
	8	541110611006M	MANUAL, INSTRUCTION(E3)	U1B	1	*
	9	943425100030M	IPOD STAND ASS'Y	CMH1A310ZA	1	
	10	943535001070D	BAG , POLY(ENGLISH/FRANCH)	CPB1061W	1	
	11	90M-ZA000240R	ANT , AM LOOP	CSA1A020Z	1	
	12	90M-ZA000220R	FM 1 POLE ANT	CSA1A018Z	1	
	13	nsp	BATTERY , AAA 2PCS IN PACK	CABR03PPB	2	
	14	nsp	SHIPPING LABEL	CQB2A323Z	2	*
	★ 15	nsp	LABEL LAST FM		1	*
	★ 16	943429007990S	ANT , DAB	CSA1A036Z	1	
	★ 17	nsp	LABEL MAC ADRESS		1	*
	18	nsp	BLACK LABEL	N1B,U1B	2	*

SEMICONDUCTORS

Only major semiconductors are shown, general semiconductors etc. are omitted to list.
The semiconductor which described a detailed drawing in a schematic diagram are omitted to list.

1. IC's

R5F64169DFD (MAIN : IC11, DISPLAY : IC81)

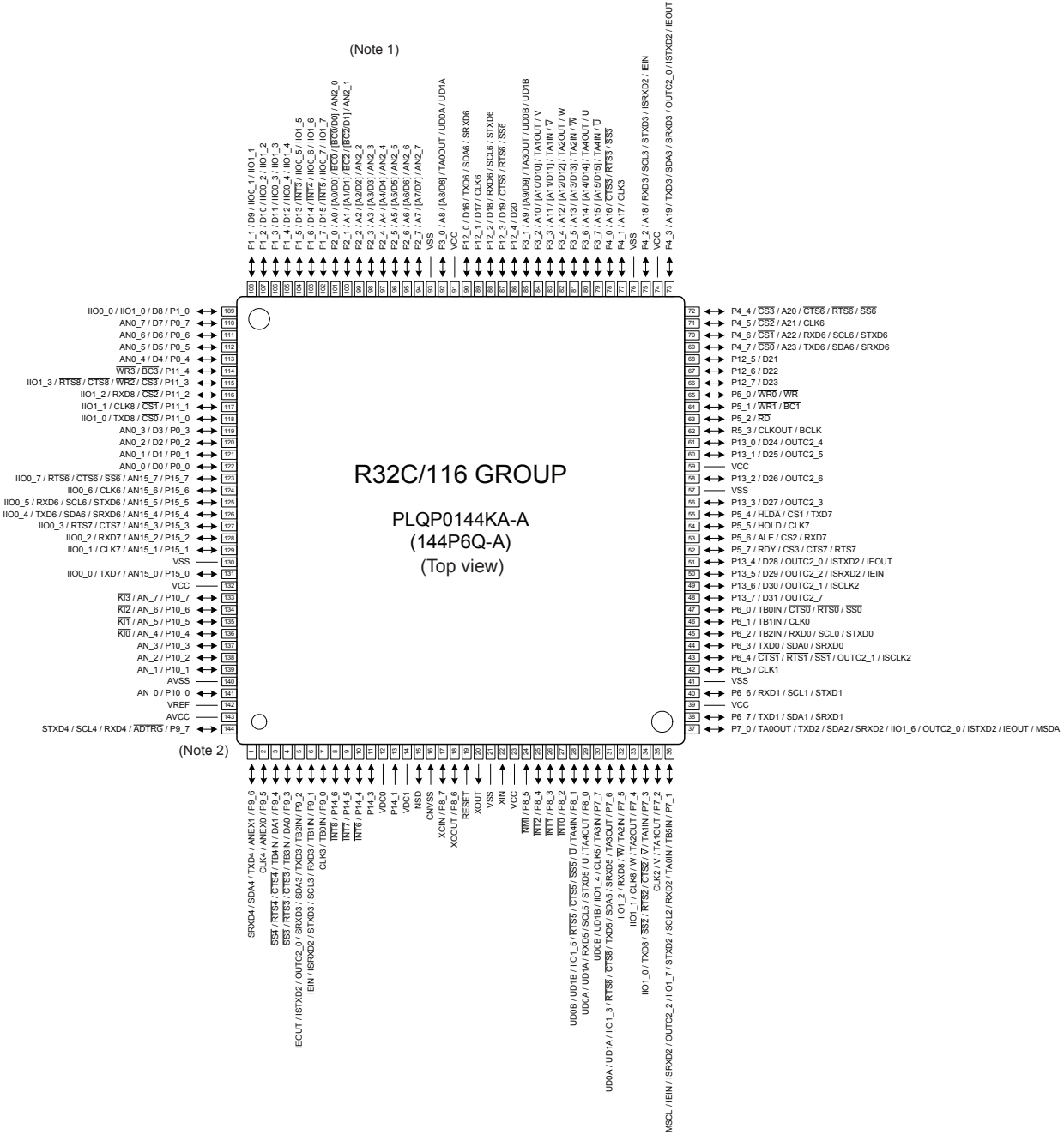

5F64169DFD (MAIN : IC11) Terminal Function

Pin No	Pin Name	Port Name	PU/ PD	I/O	STBY	Network STBY	Note
1	P96/(TXD4)	UART_MOSI	-	O	O/L	O/L	Transfer Data for Display ucom at Updating
2	(P95)/CLK4	LED_CONT1	PD	O	O/L	O/L	LED Control1
3	P94/(CTS4)	LED_CONT2	PD	O	O/L	O/L	LED Control2
4	P93/(CTS3)	OLED_CPU_POWER	PD	O	O/L	O/L	Power Control for Display ucom
5	P92/TXD3	EL_MOSI	-	O	O/L	O/L	Display Data for Display ucom
6	P91/RXD3	EL_MISO	PD	I	I	I	Display Data from Display ucom
7	P90/(CLK3)	EL_CLK	-	O	O/L	O/L	Clock of Display Data for Display ucom
8	(P146)/INT8	RDS_CLK	PD	I	I	I	RDS Clock input(interrupt)
9	P145/INT7	P_DOWN_50/60	PU	I	I	I	Power Down Detection/signal for Clock
10	P144/INT6	SP_PROTECT	PU	I	I	I	DC Protection Detection
11	P143	EL_CS	-	O	O/H	O/H	Chip Select of Display Data for Display ucom
12	VDC0	VDC0	-	-	-	-	Smoothing capacitor connection terminal
13	P141(INPUT ONLY)	CHECK-1	PD	I	I	I	NC
14	VDC1	VDC1	-	-	-	-	Smoothing capacitor connection terminal
15	NSD	NSD_M	PU	I	-	-	Emulator communication pin
16	CNVSS(INPUT ONLY)	CNVSS	PD	I	-	-	Single-chip / Micro-processor mode switching (Normal single-chip : L, Rewrite boot program start : H input set)
17	P87/(XCIN)	YOBI	-	O	O/L	O/L	Not Use
18	P86/(XCOUT)	CHECK-2	PD	I	I	I	NC
19	RESET	RESET	PU	I	-	-	Reset
20	XOUT	X2	-	-	-	-	Clock(Output)
21	VSS	VSS	-	-	-	-	GND
22	XIN	X1	-	-	-	-	Clock(Input)
23	VCC	VCC1	-	-	-	-	+3V
24	P85/NMI(INPUT ONLY)	NMI	PU	I	-	-	NC
25	P84/INT2	AUX1/DET	PU	I	I	I	AUX1(Portable In) Insertion detection
26	P83/INT1	E_REQ	PD	I	I	I	DM870/860 Interrupt
27	P82/INT0	RC_IN	PU	I	I	I	IR Interrupt
28	P81	CHECK-3	PD	I	I	I	NC
29	P80/RXD5	HP/DET	PU	I	I	I	H/P Detection
30	(P77)/CLK5	TU_SCL	PU	O	O/L	O/L	Clock for TUNER (I2C)
31	(P76)/TXD5	TU_SDA	PU	O	O/L	O/L	Data for TUNER (I2C)
32	P75/RXD8	E_SPIMIEO	PU	I	I	I	Data from ETHERNET (SPI)
33	P74/CLK8	E_SPICLK	PU	O	O/L	O/L	Clock for ETHERNET (SPI)
34	P73/TXD8	E_SPIMOEI	PU	O	O/L	O/L	Data for ETHERNET (SPI)
35	P72/CLK2	OLED_BOOT	PD	O	O/L	O/L	Boot for Display ucom
36	P71/RXD2/(MSCL)	DAB_DI	-	SI	I	I	Data from DAB (TX)
37	P70/TXD2/(MSDA)	DAB_DO	-	SO	O/L	O/L	Data for DAB (RX)
38	P67/TXD1	TXD/232CMO	-	SO	O/L	O/L	Data transfer to external terminal(AMX)/MITSUBISHI writer
39	VCC	VCC1	-	-	-	-	+3V
40	P66/RXD1	RXD/232CMI	PD	SI	I	I	Data received from the external terminal(AMX)/MITSUBISHI writer
41	VSS	VSS	-	-	-	-	GND
42	P65/CLK1/SCLK(L)	SCLK_M	PD	O	O/L	O/L	Writing Mode Select
43	P64/BUSY	BUSY_M/STEREO	-	I	I	I	STEREO Indicator input/BUSY at Updating
44	P63/TXD0	E_RXDMOEI	PU	SO	O/L	O/L	Network Serial Data Output (DM870/860 RXD)
45	P62/RXD0	E_TXDMIEO	PU	SI	I	I	Network Serial Data Input (DM870/860 TXD)
46	P61/CLK0	KILL_IR	PU	O	O/H	O/H	Control terminal for Front IR Disable
47	P60/CTS0	/H/P_MUTE	PD	O	O/L	O/L	H/P MUTE
48	P137	EL_RESET	PD	O	O/L	O/L	Reset for Display ucom
49	P136/ISCLK2	NC	-	O	O/L	O/L	NC
50	P135/ISRXD2	NC	-	O	O/L	O/L	NC
51	P134/ISTXD2	NC	-	O	O/L	O/L	NC
52	P57/RDY	RDY	PU	I	I	I	NC
53	P56/ALE	ALE	PD	O	O/L	O/L	NC
54	P55/HOLD/EPM	EPM_M	PU	I	I	I	Rewrite boot program start : L input set
55	P54/HLDA	/5142_OTW	PU	I	I	I	TAS5508 Overtemperature warning signal
56	P133	NC	-	O	O/L	O/L	NC
57	VSS	VSS	-	-	-	-	GND
58	P132	NC	-	O	O/L	O/L	NC
59	VCC	VCC2	-	-	-	-	+3V
60	P131	POWER_ON/OFF	PD	O	O/L	O/L	ON/STANDBY Control H:ON/L:STANDBY
61	P130	B_POWER_ON/OFF	PD	O	O/L	O/L	Bi-Amp Select for Power

Pin No	Pin Name	Port Name	PU/ PD	I/O	STBY	Network STBY	Note
62	P53/BCLK	NC	-	O	O/L	O/L	NC
63	P52/RD	CHECK-4	PD	I	I	I	NC
64	P51/(WR1)/BC1	SRAMSTB	PU	O	O/L	O/L	Control for TC94A92FG SRAMSTB
65	P50/(WR0)/WR/CE	CE_M	PD	I	I	I	Rewrite boot program start : H input set
66	P127	CCE	PU	O	O/L	O/L	Chip Enable for CD DSP
67	P126	BUCK	PU	O	O/L	O/L	BUS Clock for CD DSP
68	P125	NC	-	O	O/L	O/L	NC
69	P47/CS0/(A23)	BUS3	PU	O	O/L	O/L	BUS3 for CD DSP
70	P46/CS1/A22	BUS2	PU	O	O/L	O/L	BUS2 for CD DSP
71	P45/CS2/A21	BUS1	PU	O	O/L	O/L	BUS1 for CD DSP
72	P44/CS3/A20	BUS0	PU	O	O/L	O/L	BUS0 for CD DSP
73	P43/A19	OPSW	PU	I	I	I	Open SW from CD Mecha
74	VCC	VCC	-	-	-	-	+3V
75	P42/A18	CLSW	PU	I	I	I	Close SW from CD Mecha
76	VSS	VSS	-	-	-	-	GND
77	P41/A17	INSW	PU	I	I	I	Limit SW from CD Mecha
78	P40/A16	DECRST	PU	O	O/L	O/L	Reset for TC94A92FG
79	P37/A15	DREQ	-	I	I	I	TC94A92FG DREQ
80	P36/A14	SBSY	PU	I	I	I	CD Monitor3 (Default: SBSY) from TC94A92FG
81	P35/A13	DRVMUTE	PD	O	O/L	O/L	Motor stanby
82	P34/A12	OPEN	-	O	O/L	O/L	Tray Open
83	P33/A11	CLOSE	-	O	O/L	O/L	Tray Close
84	P32/A10	MX_DETECT	PU	I	I	I	M-XPort Detection
85	P31/A9	/H/P_ON	PU	O	O/L	O/L	TAS5508 Headphone in/out selector
86	P124	/PDN_5508	PD	I	I	I	TAS5508 Power down
87	P123	/5508_MUTE	PD	O	O/L	O/L	TAS5508 Soft mute of outputs
88	P122/(RXD6)	E2PROMSCL	PU	I/O	I	I	Serial Clock for EEPROM (Default:O/L)
89	P121/(CLK6)	E2PROMSDA	PU	I/O	I	I	Serial Data for EEPROM (Default:O/L)
90	P120/(TXD6)	/F_MUTE	PD	O	O/L	O/L	TAS5508 Soft mute of outputs
91	VCC	VCC	-	-	-	-	+3V
92	P30/A8	5508_SCL	PU	I/O	I	I	I2C serial Clock for TAS5508
93	VSS	VSS	-	-	-	-	GND
94	P27/A7	5508_SDA	PU	I/O	I	I	I2C serial data for TAS5508
95	P26/A6	/RESET_5508	PD	O	O/L	O/L	System Reset for TAS5508
96	P25/A5	NC	-	O	O/L	O/L	NC
97	P24/A4	NC	-	O	O/L	O/L	NC
98	P23/A3	NC	-	O	O/L	O/L	NC
99	P22/A2	4683_VOUT	-	I	I	I	AK4683 VOUT Monitor
100	P21/A1	4683_I2C_CONT	GND	I	O/L	O/L	AK4683 Communication format Select
101	P20/A0	5VCPU_ON/ OFF	PD	O	O/H	O/H	5V Control
102	P17/D15	/4683_RESET	PD	O	O/L	O/L	AK4683 Reset Signal
103	P16/D14	4683_CDTO	-	I	I	I	AK4683 SCI Data Input
104	P15/D13	4683_INT	-	I	I	I	AK4683 Request Signal
105	P14/D12	4683_CDTI	-	O	O/L	O/L	AK4683 SCI Data Output
106	P13/D11	4683_CCLK	-	O	O/L	O/L	AK4683 SCI Clock
107	P12/D10	4683_CSN	-	O	O/L	O/L	AK4683 Chip Enable Signal
108	P11/D9	/5142_SD	PU	I	I	I	TAS5508 Shutdown signal
109	P10/D8	DC_PROTECT1	PU	I	I	I	Power Protection Detect for USB
110	P07/D7	NC	-	O	O/L	O/L	NC
111	P06/D6	NC	-	O	O/L	O/L	NC
112	P05/D5	NC	-	O	O/L	O/L	NC
113	P04/D4	IPOD_DET	PU	I	I	I	iPod Detect (RCD-N7)
114	P114	SW_DOWN	PU	I	I	I	SW LEVEL Detect
115	P113	AMUTE	PD	O	O/L	O/L	AUX/SW MUTE
116	P112/(RXD8)	MX_MUTE	PD	O	O/L	O/L	NC
117	P111/	DAB-P_CONT	PD	O	O/L	O/L	Power Control for DAB
118	P110/(TXD8)	T.MUTE	PD	O	O/L	O/L	Mute for TUNER
119	P03/D3	TUNED	PU	I	I	I	Tuned
120	P02/D2	TU_POWER	PD	O	O/L	O/L	Power Control for TUNER
121	P01/D1	RDS_DATA	PD	I	I	I	RDS DATA for Eur Version
122	P00/D0	USB_P.CONT	PD	O	O/L	O/L	USB Power Control
123	P157	DC_PROTECT2	PU	I	I	I	Power Down Detect
124	P156	E_POWER_CONT	PD	O	O/L	O/H	Power Control for DM870/860
125	P155/RXD6	VBUS_MONI	PD	O	O/L	O/L	USB Data Output Enable (RCD-N7)
126	P154/TXD6	/E_SPICS	PU	O	O/L	O/L	DM870/860 SCI Chip Select
127	P153	/E_RESET	PU	O	O/L	O/H	DM870/860 Reset

Pin No	Pin Name	Port Name	PU/ PD	I/O	STBY	Network STBY	Note
128	P152/RXD7	HVBUS_CTL1	PD	O	O/L	O/L	USB1 VBUS Control
129	P151/(CLK7)	FAULT_FLAG1	PU	I	I	I	USB1 VBUS Current Limit Signal
130	VSS	VSS	-	-	-	-	GND
131	P150/TXD7	/B1/B2	PD	O	O/L	O/L	USB BUS Switch Control (RCD-N7)
132	VCC	VCC	-	-	-	-	+3V
133	P107/(AN7)/(K13)	HVBUS_CTL2	PD	O	O/L	O/L	USB2 VBUS Control (RCD-N7)
134	P106/AN6/K12	KEY3	PU	I	I	I	Key Input3
135	P105/AN5/K11	KEY2	PU	I	I	I	Key Input2
136	P104/AN4/K10	KEY1	PU	I	I	I	Key Input1
137	P103/AN3	FAULT_FLAG2	PU	I	I	I	USB2 VBUS Current Limit Signal (RCD-N7)
138	P102/AN2	LD_CHK	-	I	I	I	Laser Current Check
139	P101/(AN1)	MODEL_1	PU	I	I	I	Version Select
140	AVSS	AVSS	-	-	-	-	GND
141	P100/AN0	MODEL_2	PU	I	I	I	Model Select
142	VREF	VREF	-	-	-	-	+3V
143	AVCC	AVCC	-	-	-	-	+3V
144	(P97)/RXD4	UART_MISO	-	I	I	I	Receive Data for Display ucom at Updating

R5F64169DFD (DISPLAY : IC81) Terminal Function

Pin No	Port Name	Symbol	I/O	Pull-U/D	Note
1	P96/(TXD4)	NC	O	PD(OPEN)	NC
2	(P95)/CLK4	NC	O	-	NC
3	P94/(CTS4)	NC	O	-	NC
4	P93/(CTS3)	NC	O	-	NC
5	P92/TXD3	NC	O	-	NC
6	P91/RXD3	NC	O	-	NC
7	P90/(CLK3)	NC	O	-	NC
8	(P146)/INT8	NC	O	-	NC
9	P145/INT7	NC	O	-	NC
10	P144/INT6	NC	O	-	NC
11	P143	NC	O	-	NC
12	VDC0	VDC0	-	-	Smoothing capacitor connection terminal
13	P141(INPUT ONLY)	NC	I	PD	NC
14	VDC1	VDC1	-	-	Smoothing capacitor connection terminal
15	NSD	NSD	-	PU	Emulator communication pin
16	CNVSS(INPUT ONLY)	CNVSS	I	PD	Single-chip / Micro-processor mode switching (Normal single-chip : L, Rewrite boot program start : H input set)
17	P87/(XCIN)	NC	O	-	NC
18	P86/(XCOUT)	NC	I	PD	NC
19	RESET	OLED_RESET	I	PU	Reset input(Reset ="L")
20	XOUT	X2	-	-	Clock output
21	VSS	VSS	-	-	GND
22	XIN	X1	-	-	Clock input
23	VCC	VCC1	-	-	+3V
24	P85/NMI	NMI	I	PU	NC
25	P84/INT2	NC	O	-	NC
26	P83/INT1	YOB1	O	-	Not use
27	P82/INT0	OLED_CS	O	-	Chip Select of Display Data for Display ucom
28	P81	NC	I	PD	NC
29	P80/RXD5	BOOT	I	PD	Boot signal
30	(P77)/CLK5	NC	O	-	NC
31	(P76)/TXD5	NC	O	-	NC
32	P75/RXD8	OLED_POWER	O	PD	OLED Power On/Off
33	P74/CLK8	NC	O	-	NC
34	P73/TXD8	NC	O	-	NC
35	P72/CLK2	OLED_CLK	O	-	Clock of Display Data for Display ucom
36	P71/RXD2/(MSCL)	OLED_TX	O	-	Display Data for Display ucom
37	P70/TXD2/(MSDA)	OLED_RX	O	-	Not use
38	P67/TXD1	TXD CO	O	PD	Data transfer to external terminal(AMX)/MITSUBISHI writer
39	VCC	VCC1	-	-	+3V
40	P66/RXD1	RXD CO	I	PD	Data received from the external terminal(AMX)/MITSUBISHI writer
41	VSS	VSS	-	-	GND
42	P65/CLK1/SCLK(L)	SCLK_CO	O	PD	Writing Mode Select
43	P64/BUSY	BUSY_CO	O	-	BUSY Output at updating
44	P63/TXD0	OLED_UART_RX	O	-	Transfer Data for Display ucom at Updating
45	P62/RXD0	OLED_UART_TX	I	-	Receive Data for Display ucom at Updating
46	P61/CLK0	NC	O	-	NC
47	P60/CTS0	NC	O	-	NC
48	P137	D7	O	-	Data Bus for OLED
49	P136/ISCLK2	D6	O	-	Data Bus for OLED
50	P135/ISRXD2	D5	O	-	Data Bus for OLED
51	P134/ISTXD2	D4	O	-	Data Bus for OLED
52	P57/RDY	NC	O	-	NC
53	P56/ALE	NC	O	-	NC
54	P55/HOLD/EPM	EPM	I	PU	Rewrite boot program start : L input set
55	P54/HLDA	NC	O	-	NC
56	P133	D3	O	-	Data Bus for OLED
57	VSS	VSS	-	-	GND
58	P132	D2	O	-	Data Bus for OLED
59	VCC	VCC2	-	-	+3V
60	P131	D1	O	-	Data Bus for OLED
61	P130	D0	O	-	Data Bus for OLED
62	P53/BCLK	NC	O	-	NC
63	P52/RD	NC	I	PD	NC
64	P51/(WR1)/BC1	NC	O	-	NC

Pin No	Port Name	Symbol	I/O	Pull-U/D	Note
65	P50/(WR0)/WR/CE	CE_M	I	PD	Rewrite boot program start : H input set
66	P127	RES#	O	-	Reset, Active "L" for OLED
67	P126	CS#	O	-	Chip select : "L" for OLED (I/F communicate possible)
68	P125	RES#	O	-	Reset, Active : "L" for OLED
69	P47/(CS0)/(A23)	R/W#,WR#	O	-	Write (This pin stays "L"(low) in Serial Interface Mode) for OLED
70	P46/(CS1)/A22	E,RD#	O	-	Read (This pin stays "L"(low) in Serial Interface Mode) for OLED
71	P45/(CS2)/A21	NC	O	-	NC
72	P44/(CS3)/A20	NC	O	-	NC
73	P43/A19	NC	O	-	NC
74	VCC	VCC	-	-	+3V
75	P42/A18	NC	O	-	NC
76	VSS	VSS	-	-	GND
77	P41/A17	NC	O	-	NC
78	P40/A16	NC	O	-	NC
79	P37/A15	NC	O	-	NC
80	P36/A14	NC	O	-	NC
81	P35/A13	NC	O	-	NC
82	P34/A12	NC	O	-	NC
83	P33/A11	NC	O	-	NC
84	P32/A10	NC	O	-	NC
85	P31/A9	NC	O	-	NC
86	P124	NC	O	-	NC
87	P123	NC	O	-	NC
88	P122/(RXD6)	NC	O	-	NC
89	P121/(CLK6)	NC	O	-	NC
90	P120/(TXD6)	NC	O	-	NC
91	VCC	VCC	-	-	+3V
92	P30/A8	NC	O	-	NC
93	VSS	VSS	-	-	GND
94	P27/A7	NC	O	-	NC
95	P26/A6	NC	O	-	NC
96	P25/A5	NC	O	-	NC
97	P24/A4	NC	O	-	NC
98	P23/A3	NC	O	-	NC
99	P22/A2	NC	O	-	NC
100	P21/A1	NC	O	-	NC
101	P20/A0	NC	O	-	NC
102	P17/D15	NC	O	-	NC
103	P16/D14	NC	O	-	NC
104	P15/D13	NC	O	-	NC
105	P14/D12	NC	O	-	NC
106	P13/D11	NC	O	-	NC
107	P12/D10	NC	O	-	NC
108	P11/D9	NC	O	-	NC
109	P10/D8	NC	O	-	NC
110	P07/D7	NC	O	-	NC
111	P06/D6	NC	O	-	NC
112	P05/D5	NC	O	-	NC
113	P04/D4	NC	O	-	NC
114	P114	NC	O	-	NC
115	P113	NC	O	-	NC
116	P112/(RXD8)	NC	O	-	NC
117	P111/	NC	O	-	NC
118	P110/(TXD8)	NC	O	-	NC
119	P03/D3	NC	O	-	NC
120	P02/D2	NC	O	-	NC
121	P01/D1	NC	O	-	NC
122	P00/D0	NC	O	-	NC
123	P157	NC	O	-	NC
124	P156	NC	O	-	NC
125	P155/RXD6	NC	O	-	NC
126	P154/TXD6	NC	O	-	NC
127	P153	NC	O	-	NC
128	P152/RXD7	NC	O	-	NC
129	P151/(CLK7)	NC	O	-	NC
130	VSS	VSS	-	-	GND
131	P150/TXD7	NC	O	-	NC

Pin No	Port Name	Symbol	I/O	Pull-U/D	Note
132	VCC	VCC	-	-	+3V
133	P107/(AN7)/(KI3)	NC	O	-	NC
134	P106/AN6/KI2	NC	O	-	NC
135	P105/AN5/KI1	NC	O	-	NC
136	P104/AN4/KI0	NC	O	-	NC
137	P103/AN3	NC	O	-	NC
138	P102/AN2	NC	O	-	NC
139	P101/(AN1)	NC	O	-	NC
140	AVSS	AVSS	-	-	GND
141	P100/AN0	NC	I	PD	Not use
142	VREF	VREF	-	-	+3V
143	AVCC	AVCC	-	-	+3V
144	(P97)/RXD4	NC	O	-	NC

TC94A92FG (MAIN : IC21)

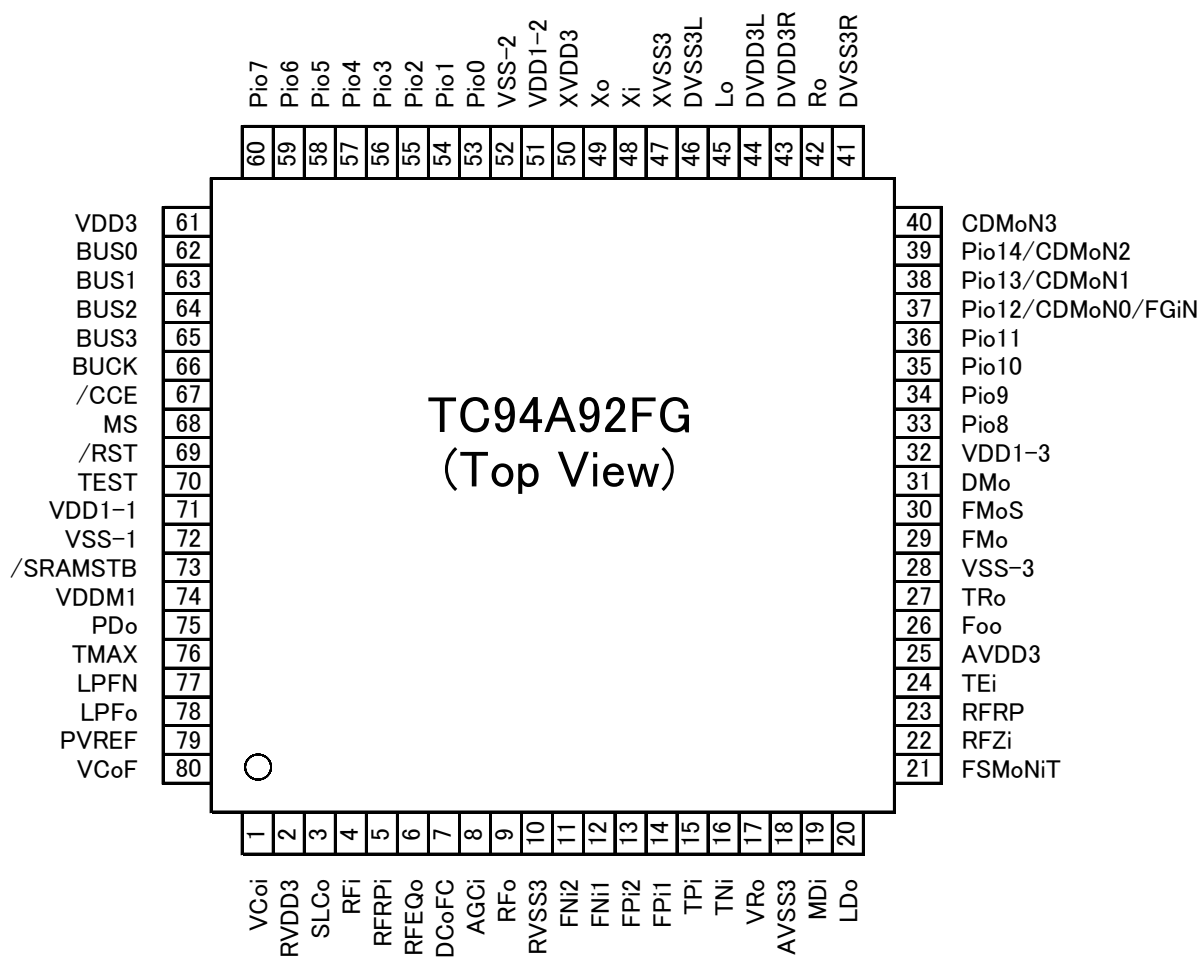

TC94A92FG Block Diagram

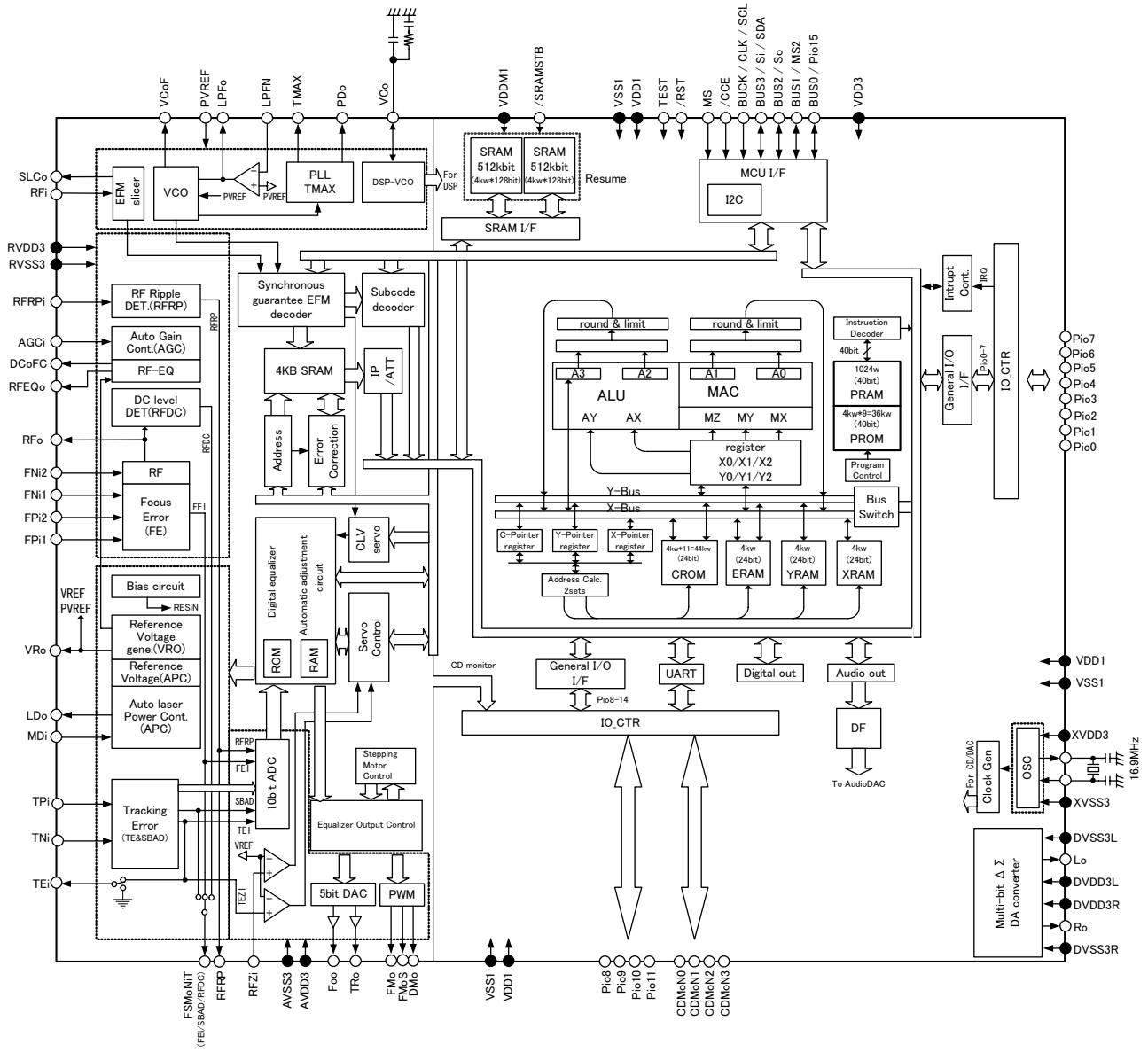

TC94A92FG Terminal Function

Pin No.	Symbol	I/O	Description	Default	Remarks
1	VCoi	O 3A/I/F	DSP VCO - EFM and PLCK Phase difference signal output pin. (DSP VCO control voltage input pin.)	O	3 state output
2	RVDD3	-	CD-DSP-Power supply for 3.3V RF amplifier core and PLL circuit	-	
3	SLCo	O 3A/I/F	EFM slice level output pin	O	Connect capacitor according with servo frequency band.
4	RFi	I 3A/I/F	RF signal input pin	I	Selectable Zin 20/10 kΩ
5	RFRPi	I 3A/I/F	RF ripple signal input pin	I	
6	RFEQo	O 3A/I/F	RF equalizer circuit output pin.	O	Connect to RFRPi by 0.1uF, to RFi by 4700pF.
7	DCoFC	O 3A/I/F	RFEQo offset compensation LPF output	O	Connect to Vro by more than 0.015uF
8	AGCi	I 3A/I/F	RF signal AGC amplifier input pin	I	
9	RFo	O 3A/I/F	RF signal generation amplifier output pin	O	
10	RVSS3	-	Grounding pin for 3.3 RF amplifier core and PLL circuit	-	
11	FNI2	I 3A/I/F	Main beam signal input pin. To be connected to PIN diode C.	I	
12	FNI1	I 3A/I/F	Main beam signal input pin. To be connected to PIN diode A.	I	
13	FPI2	I 3A/I/F	Main beam signal input pin. To be connected to PIN diode D.	I	
14	FPI1	I 3A/I/F	Main beam signal input pin. To be connected to PIN diode B.	I	
15	TPI	I 3A/I/F	Sub beam signal input pin. To be connected to PIN diode F.	I	
16	TNi	I 3A/I/F	Sub beam signal input pin. To be connected to PIN diode E.	I	
17	VRo	O 3A/I/F	1.65 V reference voltage output pin.	O	Connected to PVREF, And connect to GNG by 0.1uF+100uF.
18	AVSS3	-	Grounding pin for 3.3V CD analog circuits.	-	
19	MDi	I 3A/I/F	Monitor photodiode amplifier input pin.	I	Reference Voltage=178mVtyp.
20	LDo	O 3A/I/F	Laser diode amplifier output pin	O	

Pin No.	Symbol	I/O	Description	Default	Remarks
21	FSMoNiT	O 3A/I/F	Focus Error signal / Sub beam add signal output pin(monitor pin/GND)	O	
22	RFZi	I 3A/I/F	RF ripple zero-cross signal Input pin	I	
23	RFRP	O 3A/I/F	RF ripple signal output pin.	O	
24	TEi	O 3A/I/F	Tracking error signal output pin.	O	Built-in series R=500Ω. Connect to VRo by capacitor.
25	AVDD3	-	Power supply pin for 3.3 V CD analog circuits.	-	
26	FOo	O 3A/I/F	Focus servo equalizer output pin.	O	Built-in series R=3.3 kΩ
27	TRo	O 3A/I/F	Tracking servo equalizer output pin.	O	Built-in output R=3.3 kΩ
28	VSS-3	-	Grounding pin for 1.5V Decoder-DSP CD circuit	-	
29	FMo	O 3A/I/F	Feed servo equalizer output pin.	O	Built-in output R=3.3 kΩ
30	FMoS	O 3A/I/F	Feed servo equalizer output pin. (Stepper motor application)	O	Built-in output R=3.3 kΩ
31	DMo	O 3A/I/F	Disc servo equalizer output pin	O	Built-in output R=3.3 kΩ
32	VDD1-3	I/O 3I/F	Power supply pin for 1.5V Decoder-DSP /CD circuit	-	
33	Pio8	I/O 3I/F	Port 8 (General Input/Output Port)	I	CMOS Port Schmitt input Refer to [1.2 Pin Assinment Table]
34	Pio9	I/O 3I/F	Port 9 (General Input/Output Port)	I	CMOS Port Schmitt input Refer to [1.2 Pin Assinment Table]
35	Pio10	I/O 3I/F	Port 10 (General Input/Output Port)	I	CMOS Port Schmitt input Refer to [1.2 Pin Assinment Table]
36	Pio11	I/O 3I/F	Port 11 (General Input/Output Port)	I	CMOS Port Schmitt input Refer to [1.2 Pin Assinment Table]
37	Pio12/ CDMoN0/ FGiN	I/O 3I/F	Port 12 (General Input/Output Port) / CD Monitor 0 / FG signal input	I	CMOS Port Schmitt input Refer to [1.2 Pin Assinment Table]
38	Pio13/ CDMoN1	I/O 3I/F	Port 13 (General Input/Output Port) / CD Monitor1	I	CMOS Port Schmitt input Refer to [1.2 Pin Assinment Table]
39	Pio14/ CDMoN2	I/O 3I/F	Port 14 (General Input/Output Port) / CD Monitor 2	I	CMOS Port Schmitt input Refer to [1.2 Pin Assinment Table]
40	CDMoN3	O 3I/F	CD Monitor3 (Default output : SBSY)	O	CMOS Port Refer to [1.2 Pin Assinment Table]

Pin No.	Symbol	I/O	Description	Default	Remarks
41	DVSS3R	-	Grounding pin for 3.3V Multi-Bit DAC circuit	-	
42	Ro	O 3A/I/F	R channel audio output pin of Audio DAC.	O	
43	DVDD3R	-	Power supply pin for 3.3V Audio DAC circuit.	-	
44	DVDD3L	-	Power supply pin for 3.3V Audio DAC circuit.	-	
45	Lo	O 3A/I/F	L channel audio output pin of Audio DAC	O	
46	DVSS3L	-	Grounding pin for 3.3V Multi-Bit DAC Circuit	-	
47	XVSS3	-	Grounding pin for 3.3V clock oscillator circuit	-	
48	Xi	I 3A/I/F	System clock Input pin	I	Xtal oscillation circuit. Connect feedback resistor 1 M Ω between Xo and Xi
49	Xo	O 3A/I/F	System clock Output pin	O	
50	XVDD3	-	Power Supply pin for 3.3V clock oscillator circuit	-	
51	VDD1-2	-	Power Supply pin for 1.5V Digital circuit	-	
52	VSS-2	-	Grounding pin for 1.5V digital circuit	-	
53	Pio0	I/O 3I/F	Port 0 (General Input/Output Port)	I	CMOS Port Schmitt input Refer to [1.2 Pin Assinment Table]
54	Pio1	I/O 3I/F	Port 1 (General Input/Output Port)	I	CMOS Port Schmitt input Refer to [1.2 Pin Assinment Table]
55	Pio2	I/O 3I/F	Port 2 (General Input/Output Port)	I	CMOS Port Schmitt input Refer to [1.2 Pin Assinment Table]
56	Pio3	I/O 3I/F	Port 3 (General Input/Output Port)	I	CMOS Port Schmitt input Refer to [1.2 Pin Assinment Table]
57	Pio4	I/O 3I/F	Port 4 (General Input/Output Port)	I	CMOS Port Schmitt input Refer to [1.2 Pin Assinment Table]
58	Pio5	I/O 3I/F	Port 5 (General Input/Output Port)	I	CMOS Port Schmitt input Refer to [1.2 Pin Assinment Table]
59	Pio6	I/O 3I/F	Port 6 (General Input/Output Port)	I	CMOS Port Schmitt input Refer to [1.2 Pin Assinment Table]
60	Pio7	I/O 3I/F	Port 7 (General Input/Output Port)	I	CMOS Port Schmitt input Refer to [1.2 Pin Assinment Table]

Pin No.	Symbol	I/O	Description	Default	Remarks
61	VDD3	-	Power Supply pin for 3.3V Digital circuit	-	
62	BUS0	I/O 3I/F	Microprocessor I/F data input/output pin 0	I	CMOS Port Schmitt input Refer to [1.2 Pin Assinment Table]
63	BUS1	I/O 3I/F	Microprocessor I/F data input/output pin 1	I	CMOS Port Schmitt input Refer to [1.2 Pin Assinment Table]
64	BUS2	I/O 3I/F	Microprocessor I/F data input/output pin 2	I	CMOS Port Schmitt input Refer to [1.2 Pin Assinment Table]
65	BUS3	I/O 3I/F	Microprocessor I/F data input/output pin 3	I	CMOS Port Schmitt input Refer to [1.2 Pin Assinment Table]
66	BUCK	I 3I/F	Microprocessor I/F BUS clock Input pin	I	Schmitt input Refer to [1.2 Pin Assinment Table]
67	/CCE	I 3I/F	Microprocessor I/F chip enable input pin	I	Schmitt input Refer to [1.2 Pin Assinment Table]
68	MS	I 3I/F	Microprocessor I/F mode selection pin. "H": Parallel I/F, "L": Serial I/F	I	Refer to [1.2 Pin Assinment Table]
69	/RST	I 3I/F	Reset Input pin	I	Schmitt input
70	Test	I 3I/F	Test pin ("L" fixed)	I	Connect to GND for normal operation
71	VDD1-1	-	Power Supply pin for 1.5V Digital circuit	-	
72	VSS-1	-	Grounding pin for 1.5V Digital circuit	-	
73	/SRAMSTB	I 3I/F	1Mbit SRAM stand by pin (/SRAMSTB="L")	I	
74	VDDM1	-	Power Supply for 1.5V 1Mbit SRAM circuit	-	
75	PDo	O 3AI/F	EFM and PLCK Phase difference signal output pin.	O	4-state output (RVDD3, RVSS3,PVREF, Hiz)
76	TMAX	O 3AI/F	TMAX detection result output pin	O	3-state output (RVDD3, RVSS3, Hiz)
77	LPFN	I 3AI/F	PLL circuit LPF amplifier inversion input pin	I	
78	LPFo	O 3AI/F	PLL circuit LPF amplifier Output pin	O	
79	PVREF	-	PLL circuit 1.65 V reference voltage pin.	-	Connected to VRO. Connect to GND by 0.1uF and 100uF.
80	VCoF	O 3AI/F	VCO filter pin	O	Connect to GND by 0.01uF

3A I/F : 3 V analog circuit input/output pin.

1.5 I/F : 1.5Vdigital input/output pin.

3 I/F : 3 V digital input/output pin.

IP4001CRLTF (MAIN : IC31)

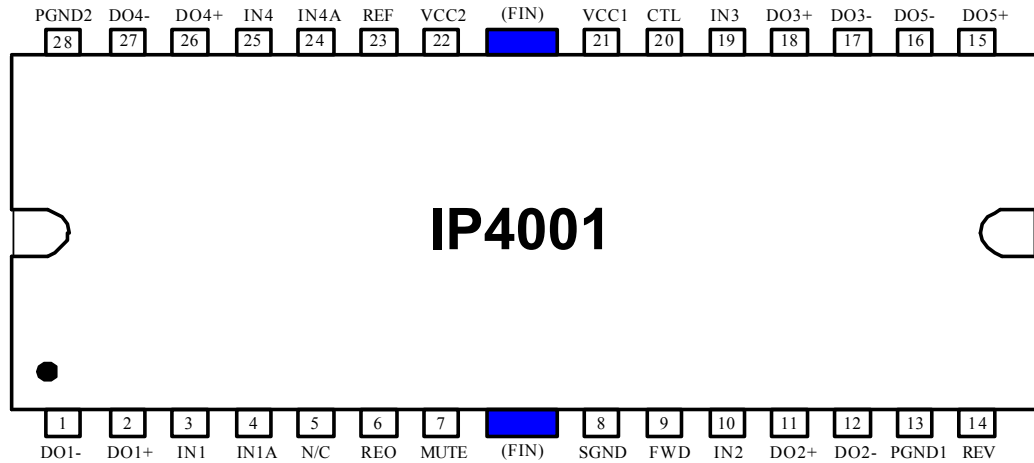

IP4001CRLTF Block Diagram

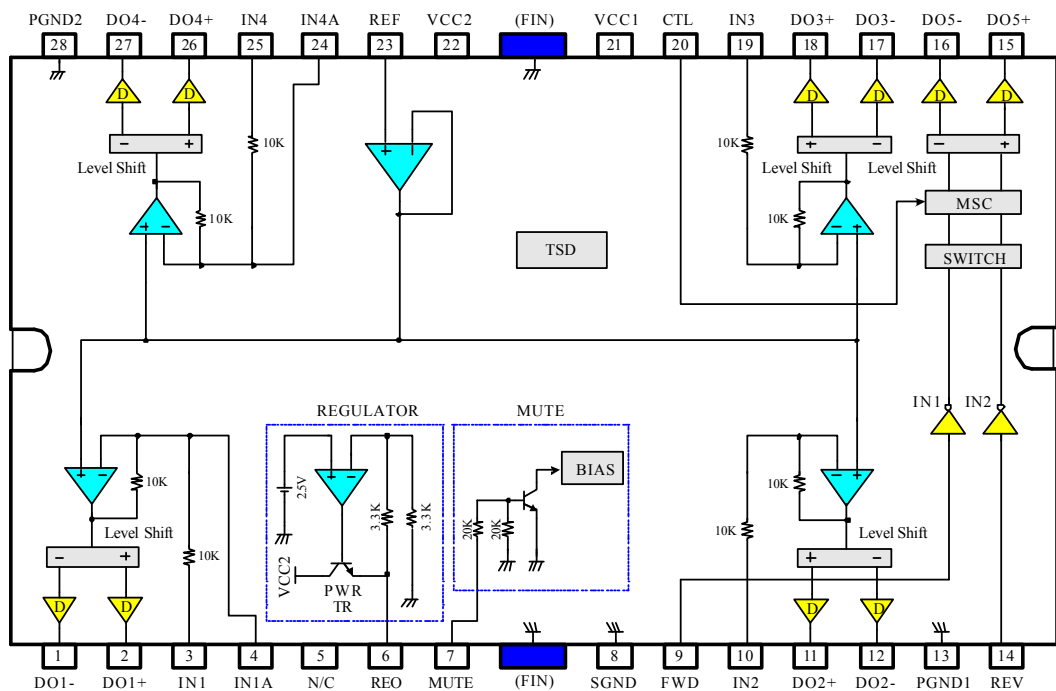

IP4001CRLTF Pin Discriptions

NO	SYMBOL	I/O	DESCRIPTION	NO	SYMBOL	I/O	DESCRIPTION
1	DO1-	O	CH1 OUTPUT (-)	15	DO5+	O	CH5 OUTPUT (+)
2	DO1+	O	CH1 OUTPUT (+)	16	DO5-	O	CH5 OUTPUT (-)
3	IN1	I	CH1 INPUT 1	17	DO3-	O	CH3 OUTPUT (-)
4	IN1A	I	CH1 INPUT 2	18	DO3+	O	CH3 OUTPUT (+)
5	N / C	-	NO-CONNECTION	19	IN3	I	CH3 INPUT
6	REO	O	REGULATOR OUTPUT	20	CTL	I	CH5 MOTOR SPEED CONTROL
7	MUTE	I	MUTE INPUT	21	VCC1	I	SUPPLY VOLTAGE 1 (CH2,CH3,CH5)
8	SGND	-	SIGNAL GROUND	22	VCC2	I	SUPPLY VOLTAGE 2 (CH1,CH4,SIGNAL,REG)
9	FWD	I	CH5 INPUT 1	23	REF	I	CH BIAS INPUT
10	IN2	I	CH2 INPUT	24	IN4A	I	CH4 INPUT 1
11	DO2+	O	CH2 OUTPUT (+)	25	IN4	I	CH4 INPUT 2
12	DO2-	O	CH2 OUTPUT (-)	26	DO4+	O	CH4 OUTPUT (+)
13	PGND1	-	POWER GROUND 1	27	DO4-	O	CH4 OUTPUT (-)
14	REV	I	CH5 INPUT 2	28	PGND2	-	POWER GROUND 2

AK4683 (MAIN : IC41)

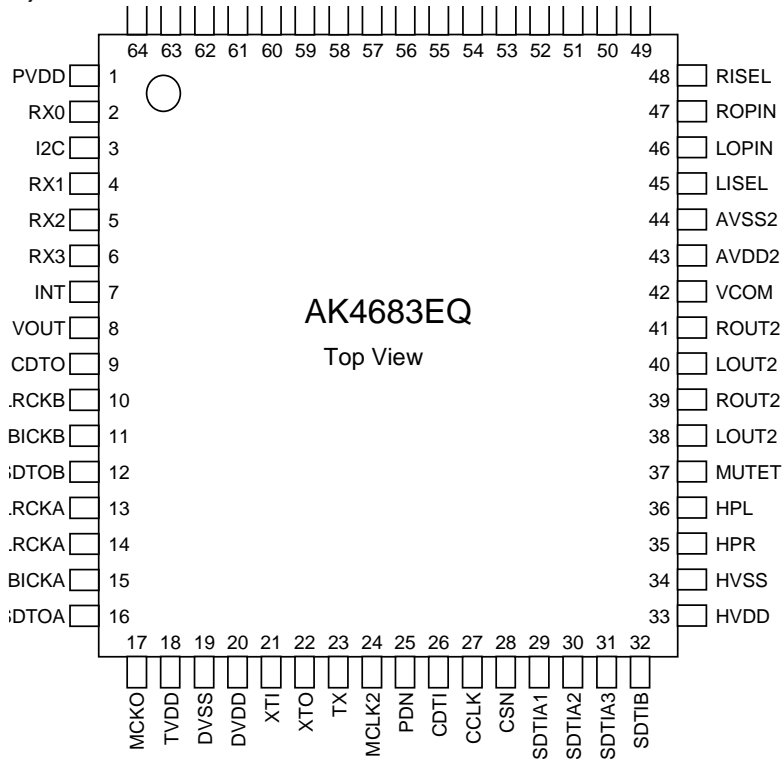

AK4683 Block Diagram

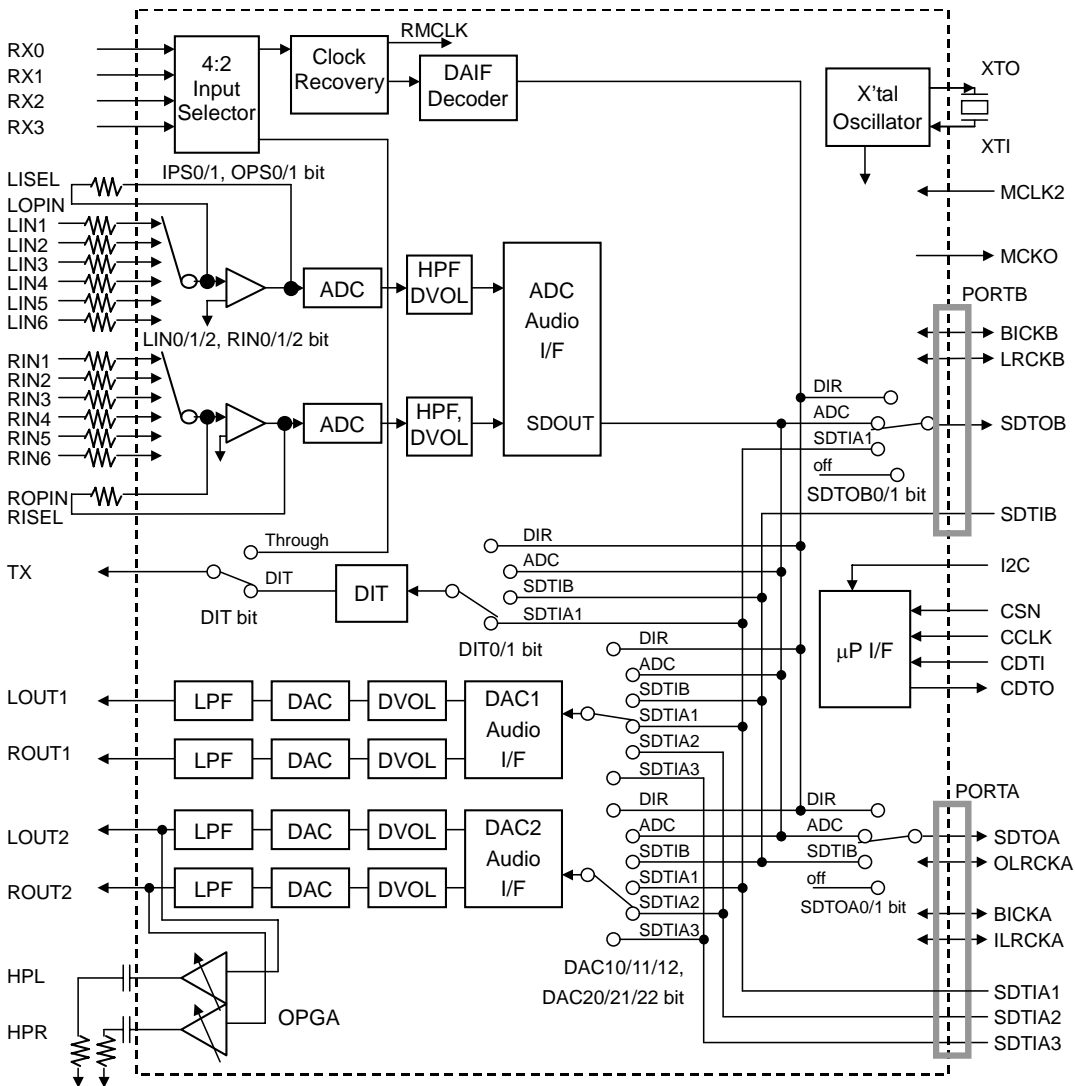

AK4683 Pin Discriptions

No.	Pin Name	I/O	Function
1	PVDD	-	PLL Power supply Pin, 4.5V~5.5V
2	RX0	I	Receiver Channel 0 Pin (Internal biased pin. Internally biased at PVDD/2)
3	I2C	I	Control Mode Select Pin. “L”: 4-wire Serial, “H”: I ² C Bus
4	RX1	I	Receiver Channel 1 Pin
5	RX2	I	Receiver Channel 2 Pin
6	RX3	I	Receiver Channel 3 Pin
7	INT	O	Interrupt Pin
8	VOUT	O	V-bit Output Pin for Receiver Input
	DZF	O	Zero Input Detect Pin When the input data of DAC follow total 8192 LRCK cycles with “0” input data, this pin goes to “H”. And when RSTN1 bit is “0”, PWDA bit is “0”, this pin goes to “H”.
	OVF	O	Analog Input Overflow Detect Pin This pin goes to “H” if the analog input of Lch or Rch overflows.
9	CDTO	O	Control Data Output Pin in Serial Mode and I2C pin = “L”.
10	LRCKB	I/O	Channel Clock B Pin
11	BICKB	I/O	Audio Serial Data Clock B Pin
12	SDTOB	O	Audio Serial Data Output B Pin
13	OLRCKA	I/O	Output Channel Clock A Pin
14	ILRCKA	I/O	Input Channel Clock A Pin
15	BICKA	I/O	Audio Serial Data Clock A Pin
16	SDTOA	O	Audio Serial Data Output A Pin
17	MCKO	O	Master Clock Output Pin
18	TVDD	-	Output Buffer Power Supply Pin, 2.7V~5.5V
19	DVSS	-	Digital Ground Pin, 0V
20	DVDD	-	Digital Power Supply Pin, 4.5V~5.5V
21	XTI	I	X’tal Input Pin
22	XTO	O	X’tal Output Pin
23	TX	O	Transmit Channel Output pin When DIT bit = “0”, RX0~3 Through. When DIT bit = “1”, Internal DIT Output.
24	MCLK2	I	Master Clock Input Pin
25	PDN	I	Power-Down Mode & Reset Pin When “L”, the AK4683 is powered-down, all registers are reset. And then all digital output pins go “L”. The AK4683 must be reset once upon power-up.
26	CDTI	I	Control Data Input Pin in Serial Mode and I2C pin = “L”.
	SDA	I/O	Control Data Pin in Serial Mode and I2C pin = “H”.
27	CCLK	I	Control Data Clock Pin in Serial Mode and I2C pin = “L”
	SCL	I	Control Data Clock Pin in Serial Mode and I2C pin = “H”
28	CSN	I	Chip Select Pin in Serial Mode and I2C pin = “L”.
	TEST	I	This pin should be connected to DVSS in Serial Mode and I2C pin = “H”.
29	SDTIA1	I	Audio Serial Data Input A1 Pin
30	SDTIA2	I	Audio Serial Data Input A2 Pin
31	SDTIA3	I	Audio Serial Data Input A3 Pin
32	SDTIB	I	Audio Serial Data Input B Pin
33	HVDD	-	HP Power Supply Pin, 4.5V~5.5V
34	HVSS	-	HP Ground Pin, 0V
35	HPR	O	HP Rch Output Pin
36	HPL	O	HP Lch Output Pin
37	MUTET	-	HP Common Voltage Output Pin 1μF capacitor should be connected to HVSS externally.

No.	Pin Name	I/O	Function
38	LOUT2	O	DAC2 Lch Positive Analog Output Pin
39	ROUT2	O	DAC2 Rch Positive Analog Output Pin
40	LOUT1	O	DAC1 Lch Positive Analog Output Pin
41	ROUT1	O	DAC1 Rch Positive Analog Output Pin
42	VCOM	-	DAC/ADC Common Voltage Output Pin 2.2 μ F capacitor should be connected to AVSS2 externally.
43	AVDD2	-	DAC Power Supply Pin, 4.5V~5.5V
44	AVSS2	-	DAC Ground Pin, 0V
45	LISEL	O	Lch Feedback Resistor Output Pin
46	LOPIN	O	Lch Feedback Resistor Input Pin, 0.5xAVDD1
47	ROPIN	O	Rch Feedback Resistor Input Pin. 0.5xAVDD1
48	RISEL	O	Rch Feedback Resistor Output Pin
49	AVSS1	-	ADC Ground Pin, 0V
50	AVDD1	-	ADC Power Supply Pin, 4.5V~5.5V
51	LIN1	I	Lch Input 1 Pin
52	RIN1	I	Rch Input 1 Pin
53	LIN2	I	Lch Input 2 Pin
54	RIN2	I	Rch Input 2 Pin
55	LIN3	I	Lch Input 3 Pin
56	RIN3	I	Rch Input 3 Pin
57	LIN4	I	Lch Input 4 Pin
58	RIN4	I	Rch Input 4 Pin
59	LIN5	I	Lch Input 5 Pin
60	RIN5	I	Rch Input 5 Pin
61	LIN6	I	Lch Input 6 Pin
62	RIN6	I	Rch Input 6 Pin
63	PVSS	-	PLL Ground pin
64	R	-	External Resistor Pin 12k Ω +/-1% resistor should be connected to PVSS externally.

TAS5142 (MAIN : IC71,72)

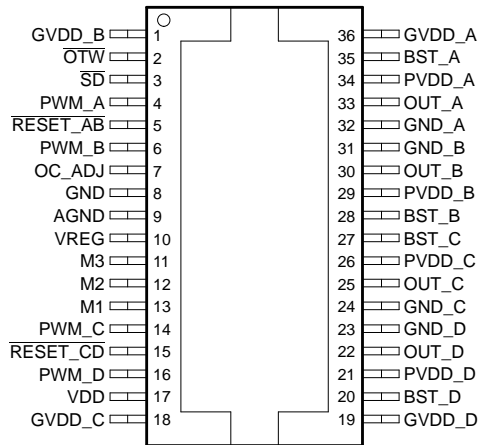

TAS5142 Pin Discriptions

TERMINAL			FUNCTION (1)	DESCRIPTION
NAME	DKD NO.	DDV NO.		
AGND	9	11	P	Analog ground
BST_A	35	43	P	HS bootstrap supply (BST), external capacitor to OUT_A required
BST_B	28	34	P	HS bootstrap supply (BST), external capacitor to OUT_B required
BST_C	27	33	P	HS bootstrap supply (BST), external capacitor to OUT_C required
BST_D	20	24	P	HS bootstrap supply (BST), external capacitor to OUT_D required
GND	8	10	P	Ground
GND_A	32	38	P	Power ground for half-bridge A
GND_B	31	37	P	Power ground for half-bridge B
GND_C	24	30	P	Power ground for half-bridge C
GND_D	23	29	P	Power ground for half-bridge D
GVDD_A	36	44	P	Gate-drive voltage supply requires 0.1-μF capacitor to AGND
GVDD_B	1	1	P	Gate-drive voltage supply requires 0.1-μF capacitor to AGND
GVDD_C	18	22	P	Gate-drive voltage supply requires 0.1-μF capacitor to AGND
GVDD_D	19	23	P	Gate-drive voltage supply requires 0.1-μF capacitor to AGND
M1	13	15	I	Mode selection pin
M2	12	14	I	Mode selection pin
M3	11	13	I	Mode selection pin
NC	–	3, 4, 19, 20, 25, 42	–	No connect. Pins may be grounded.
OC_ADJ	7	9	O	Analog overcurrent programming pin requires resistor to ground
OTW	2	2	O	Overtemperature warning signal, open-drain, active-low
OUT_A	33	39	O	Output, half-bridge A
OUT_B	30	36	O	Output, half-bridge B
OUT_C	25	31	O	Output, half-bridge C
OUT_D	22	28	O	Output, half-bridge D
PVDD_A	34	40, 41	P	Power supply input for half-bridge A requires close decoupling of 0.1-μF capacitor to GND_A.
PVDD_B	29	35	P	Power supply input for half-bridge B requires close decoupling of 0.1-μF capacitor to GND_B.
PVDD_C	26	32	P	Power supply input for half-bridge C requires close decoupling of 0.1-μF capacitor to GND_C.
PVDD_D	21	26, 27	P	Power supply input for half-bridge D requires close decoupling of 0.1-μF capacitor to GND_D.
PWM_A	4	6	I	Input signal for half-bridge A
PWM_B	6	8	I	Input signal for half-bridge B
PWM_C	14	16	I	Input signal for half-bridge C
PWM_D	16	18	I	Input signal for half-bridge D
RESET_AB	5	7	I	Reset signal for half-bridge A and half-bridge B, active-low
RESET_CD	15	17	I	Reset signal for half-bridge C and half-bridge D, active-low
SD	3	5	O	Shutdown signal, open-drain, active-low
VDD	17	21	P	Power supply for digital voltage regulator requires 0.1-μF capacitor to GND.
VREG	10	12	P	Digital regulator supply filter pin requires 0.1-μF capacitor to AGND.

(1) I = input, O = output, P = power

TAS5142 Block Diagram

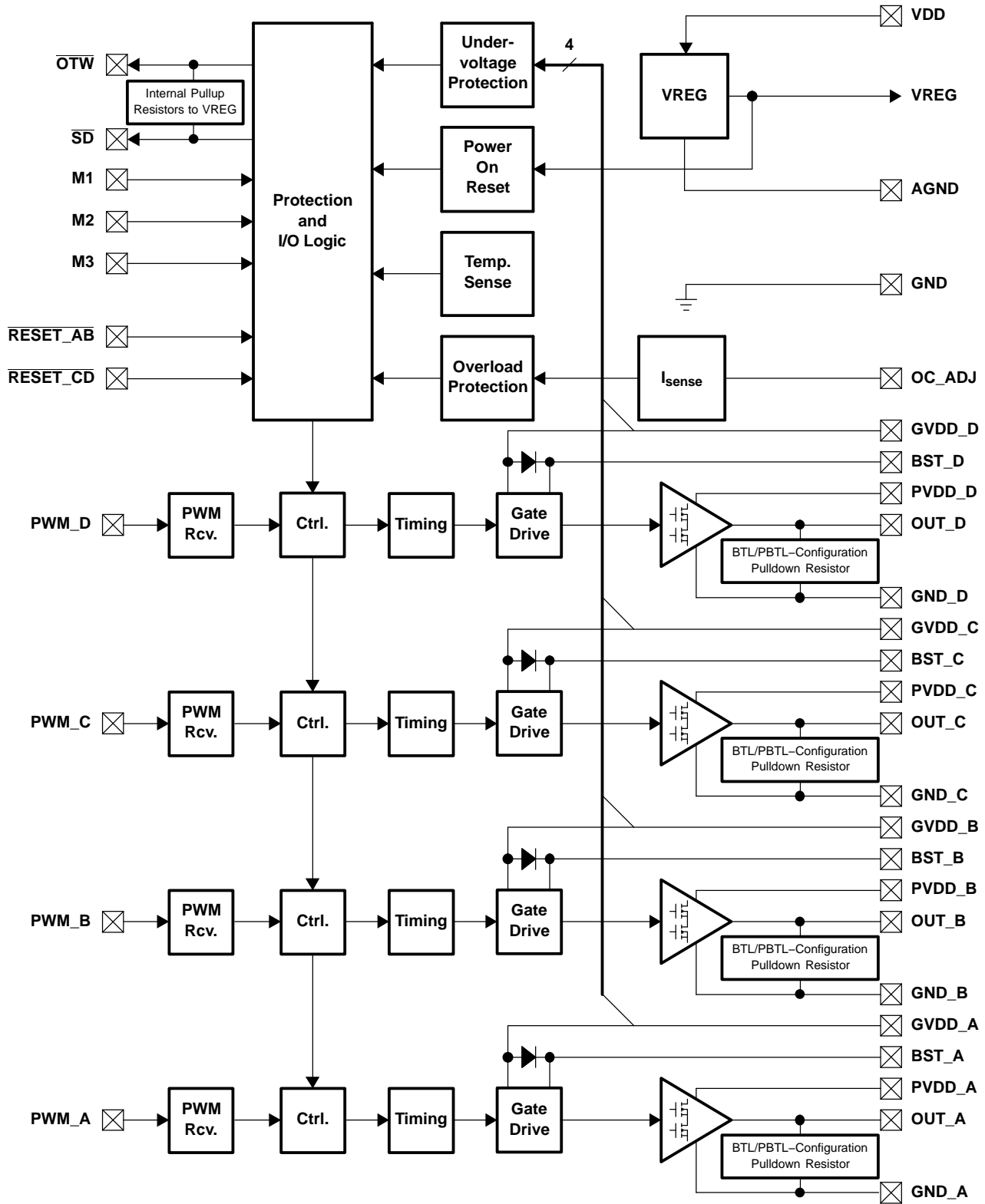

TAS5508 (MAIN : IC51)

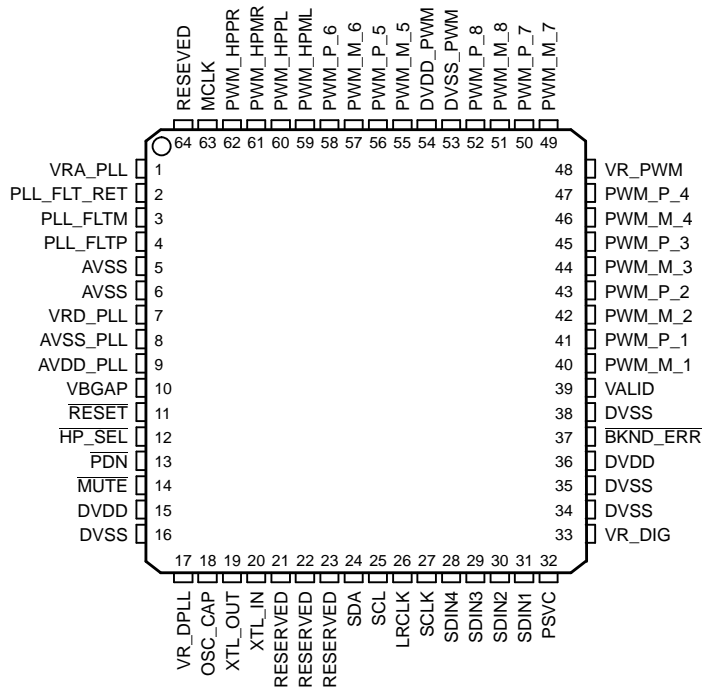

P0010-01

TAS5508 Pin Discriptions

TERMINAL		TYPE ⁽¹⁾	5-V TOLERANT	TERMINATION ⁽²⁾	DESCRIPTION
NAME	NO.				
AVDD_PLL	9	P			3.3-V analog power supply for PLL. This terminal can be connected to the same power source used to drive power terminal DVDD, but to achieve low PLL jitter, this terminal should be bypassed to AVSS_PLL with a 0.1-µF low-ESR capacitor.
AVSS	5, 6	P			Analog ground
AVSS_PLL	8	P			Analog ground for PLL. This terminal should reference the same ground as terminal DVSS, but to achieve low PLL jitter, ground noise at this terminal must be minimized. The availability of the AVSS terminal allows a designer to use optimizing techniques such as star ground connections, separate ground planes, or other quiet ground-distribution techniques to achieve a quiet ground reference at this terminal.
BKND_ERR	37	DI		Pullup	Active-low. A back-end error sequence is generated by applying logic low to this terminal. The BKND_ERR results in no change to any system parameters, with all H-bridge drive signals going to a hard-mute (M) state.
DVDD	15, 36	P			3.3-V digital power supply
DVDD_PWM	54	P			3.3-V digital power supply for PWM
DVSS	16, 34, 35, 38	P			Digital ground
DVSS_PWM	53	P			Digital ground for PWM
HP_SEL	12	DI	5 V	Pullup	Headphone in/out selector. When a logic low is applied, the headphone is selected (speakers are off). When a logic high is applied, speakers are selected (headphone is off).
LRCLK	26	DI	5 V		Serial-audio data left/right clock (sampling-rate clock)
MCLK	63	DI	5 V	Pulldown	MCLK is a 3.3-V master clock input. The input frequency of this clock can range from 4 MHz to 50 MHz.
MUTE	14	DI	5 V	Pullup	Soft mute of outputs, active-low (muted signal = a logic low, normal operation = a logic high). The mute control provides a noiseless volume ramp to silence. Releasing mute provides a noiseless ramp to previous volume.
OSC_CAP	18	AO			Oscillator capacitor
PDN	13	DI	5 V	Pullup	Power down, active-low. PDN powers down all logic and stops all clocks whenever a logic low is applied. The internal parameters are preserved through a power-down cycle, as long as RESET is not active. The duration for system recovery from power down is 100 ms.
PLL_FLT_RET	2	AO			PLL external filter return
PLL_FLTM	3	AO			PLL negative input. Connected to PLL_FLT_RTIN via an RC network
PLL_FLTP	4	AI			PLL positive input. Connected to PLL_FLT_RTIN via an RC network
PSVC	32	O			Power-supply volume control PWM output
PWM_HPML	59	DO			PWM left-channel headphone (differential -)
PWM_HPMR	61	DO			PWM right-channel headphone (differential -)
PWM_HPPL	60	DO			PWM left-channel headphone (differential +)
PWM_HPPR	62	DO			PWM right-channel headphone (differential +)
PWM_M_1	40	DO			PWM 1 output (differential -)
PWM_M_2	42	DO			PWM 2 output (differential -)
PWM_M_3	44	DO			PWM 3 output (differential -)
PWM_M_4	46	DO			PWM 4 output (differential -)
PWM_M_5	55	DO			PWM 5 output (differential -)
PWM_M_6	57	DO			PWM 6 output (differential -)
PWM_M_7	49	DO			PWM 7 (lineout L) output (differential -)
PWM_M_8	51	DO			PWM 8 (lineout R) output (differential -)
PWM_P_1	41	DO			PWM 1 output (differential +)
PWM_P_2	43	DO			PWM 2 output (differential +)

(1) Type: A = analog; D = 3.3-V digital; P = power/ground/decoupling; I = input; O = output
 (2) All pullups are 200-mA weak pullups and all pulldowns are 200-mA weak pulldowns. The pullups and pulldowns are included to ensure proper input logic levels if the terminals are left unconnected (pullups => logic-1 input; pulldowns => logic-0 input). Devices that drive inputs with pullups must be able to sink 200 mA, while maintaining a logic-0 drive level. Devices that drive inputs with pulldowns must be able to source 200 mA, while maintaining a logic-1 drive level.

TERMINAL		TYPE ⁽¹⁾	5-V TOLERANT	TERMINATION ⁽²⁾	DESCRIPTION
NAME	NO.				
PWM_P_3	45	DO			PWM 3 output (differential +)
PWM_P_4	47	DO			PWM 4 output (differential +)
PWM_P_5	56	DO			PWM 5 output (differential +)
PWM_P_6	58	DO			PWM 6 output (differential +)
PWM_P_7	50	DO			PWM 7 (lineout L) output (differential +)
PWM_P_8	52	DO			PWM 8 (lineout R) output (differential +)
RESERVED	21, 22, 23, 64				Connect to digital ground
RESET	11	DI	5 V	Pullup	System reset input, active-low. A system reset is generated by applying a logic low to this terminal. RESET is an asynchronous control signal that restores the TAS5508 to its default conditions, sets the valid output low, and places the PWM in the hard mute (M) state. Master volume is immediately set to full attenuation. On the release of RESET, if PDN is high, the system performs a 4- to 5-ms device initialization and sets the volume at mute.
SCL	25	DI	5 V		I ² C serial-control clock input/output
SCLK	27	DI	5 V		Serial-audio data clock (shift clock) input
SDA	24	DIO	5 V		I ² C serial-control data-interface input/output
SDIN1	31	DI	5 V	Pulldown	Serial-audio data input 1 is one of the serial-data input ports. SDIN1 supports four discrete (stereo) data formats and is capable of inputting data at 64 Fs.
SDIN2	30	DI	5 V	Pulldown	Serial-audio data input 2 is one of the serial-data input ports. SDIN2 supports four discrete (stereo) data formats and is capable of inputting data at 64 Fs.
SDIN3	29	DI	5 V	Pulldown	Serial-audio data input 3 is one of the serial-data input ports. SDIN3 supports four discrete (stereo) data formats and is capable of inputting data at 64 Fs.
SDIN4	28	DI	5 V	Pulldown	Serial-audio data input 4 is one of the serial-data input ports. SDIN4 supports four discrete (stereo) data formats and is capable of inputting data at 64 Fs.
VALID	39	DO			Output indicating validity of PWM outputs, active-high
VBGAP	10	P			Band-gap voltage reference. A pinout of the internally regulated 1.2-V reference. Typically has a 1-nF low-ESR capacitor between VBGAP and AVSS_PLL. This terminal must not be used to power external devices.
VR_DIG	33	P			Voltage reference for 1.8-V digital core supply. A pinout of the internally regulated 1.8-V power used by digital core logic. A 4.7- μ F low-ESR capacitor ⁽³⁾ should be connected between this terminal and DVSS. This terminal must not be used to power external devices.
VR_DPLL	17	P			Voltage reference for 1.8-V digital PLL supply. A pinout of the internally regulated 1.8-V power used by digital PLL logic. A 0.1- μ F low-ESR capacitor ⁽³⁾ should be connected between this terminal and DVSS_CORE. This terminal must not be used to power external devices.
VR_PWM	48	P			Voltage reference for 1.8-V digital PWM core supply. A pinout of the internally regulated 1.8-V power used by digital PWM core logic. A 0.1- μ F low-ESR capacitor ⁽³⁾ should be connected between this terminal and DVSS_PWM. This terminal must not be used to power external devices.
VRA_PLL	1	P			Voltage reference for 1.8-V PLL analog supply. A pinout of the internally regulated 1.8-V power used by PLL logic. A 0.1- μ F low-ESR capacitor ⁽³⁾ should be connected between this terminal and AVSS_PLL. This terminal must not be used to power external devices.
VRD_PLL	7	P			Voltage reference for 1.8-V PLL digital supply. A pinout of the internally regulated 1.8-V power used by PLL logic. A 0.1- μ F low-ESR capacitor ⁽³⁾ should be connected between this terminal and AVSS_PLL. This terminal must not be used to power external devices.
XTL_IN	20	AI			XTL_OUT and XTL_IN are the only LVCMOS terminals on the device. They provide a reference clock for the TAS5508 via use of an external fundamental-mode crystal. XTL_IN is the 1.8-V input port for the oscillator circuit. A 13.5-MHz crystal (HCM49) is recommended.
XTL_OUT	19	AO			XTL_OUT and XTL_IN are the only LVCMOS terminals on the device. They provide a reference clock for the TAS5508 via use of an external fundamental-mode crystal. XTL_OUT is the 1.8-V output drive to the crystal. A 13.5-MHz crystal (HCM49) is recommended.

- (3) If desired, low-ESR capacitance values can be implemented by paralleling two or more ceramic capacitors of equal value. Paralleling capacitors of equal value provides an extended high-frequency supply decoupling. This approach avoids the potential of producing parallel resonance circuits that have been observed when paralleling capacitors of different values.

TAS5508 Block Diagram

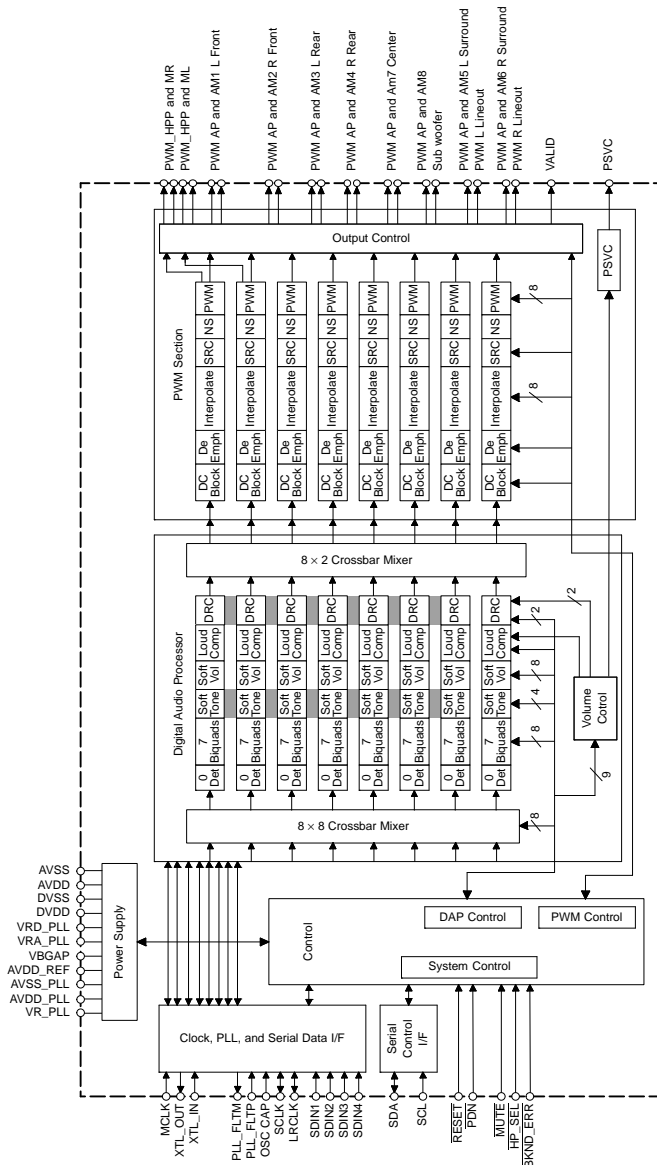

B0011-01

ICE3B0365J (SMPS : IC91)

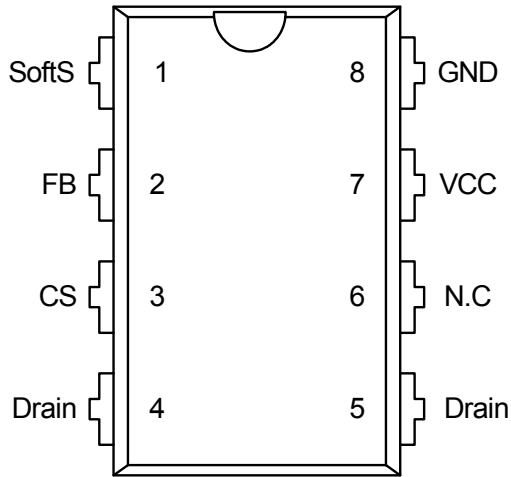

Pin	Symbol	Function
1	SoftS	Soft-Start
2	FB	Feedback
3	CS	Current Sense/ 650V ¹⁾ Depl. CoolMOS™ Source
4	Drain	650V ¹⁾ Depl. CoolMOS™ Drain
5	Drain	650V ¹⁾ Depl. CoolMOS™ Drain
6	N.C.	Not Connected
7	VCC	Controller Supply Voltage
8	GND	Controller Ground

1) at T_J = 110°C

ICE3B0365J Block Diagram

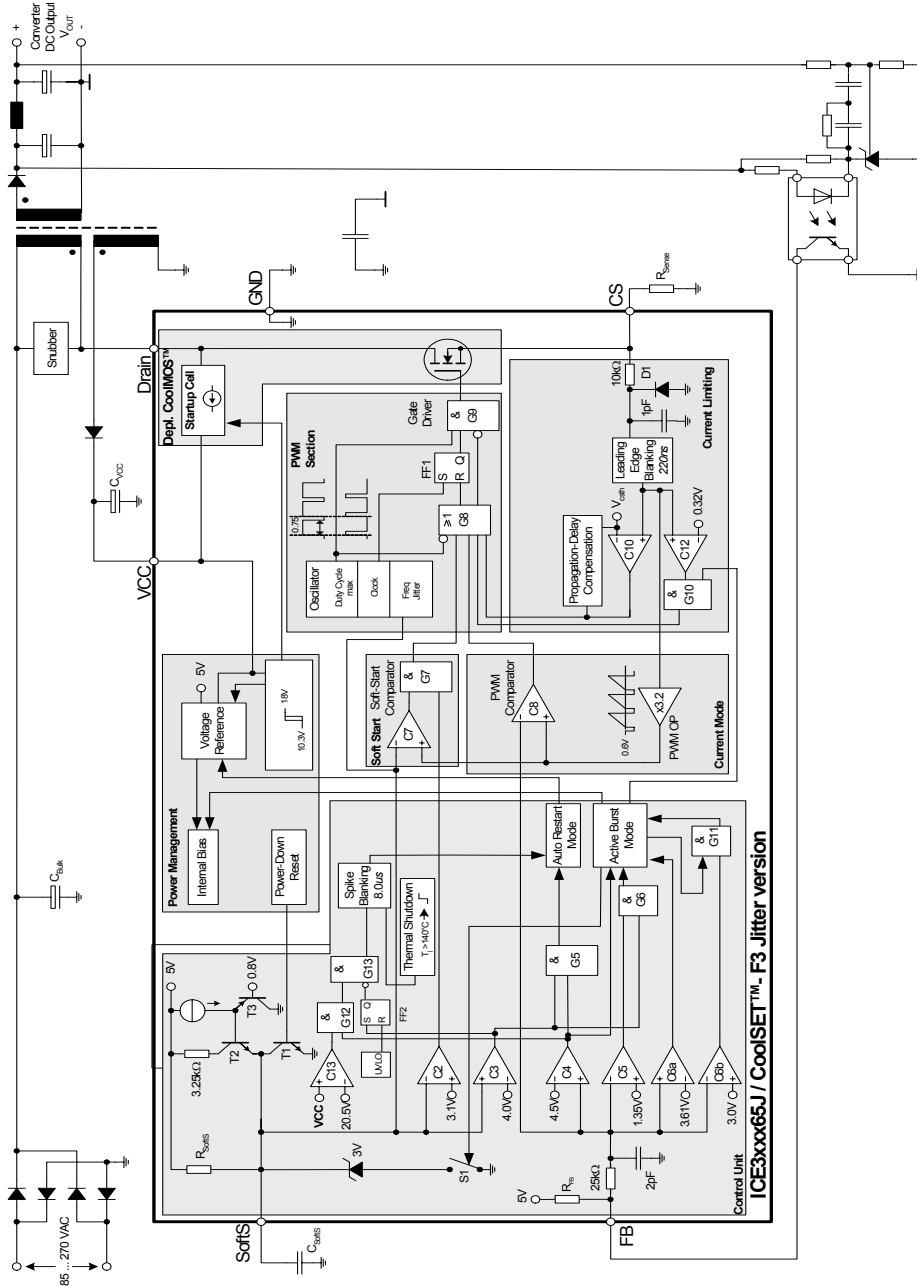

ICE2B265 (SMPS : IC92)

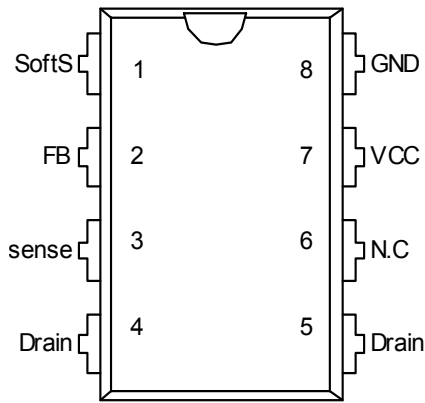

Pin	Symbol	Function
1	SoftS	Soft-Start
2	FB	Feedback
3	Isense	Controller Current Sense Input, CoolMOS™ Source Output
4	Drain	650V ¹⁾ /800V ²⁾ CoolMOS™ Drain
5	Drain	650V ¹⁾ /800V ²⁾ CoolMOS™ Drain
6	N.C	Not connected
7	VCC	Controller Supply Voltage
8	GND	Controller Ground

1) at $T_j = 110^\circ\text{C}$

2) at $T_j = 25^\circ\text{C}$

ICE2B265 Block Diagram

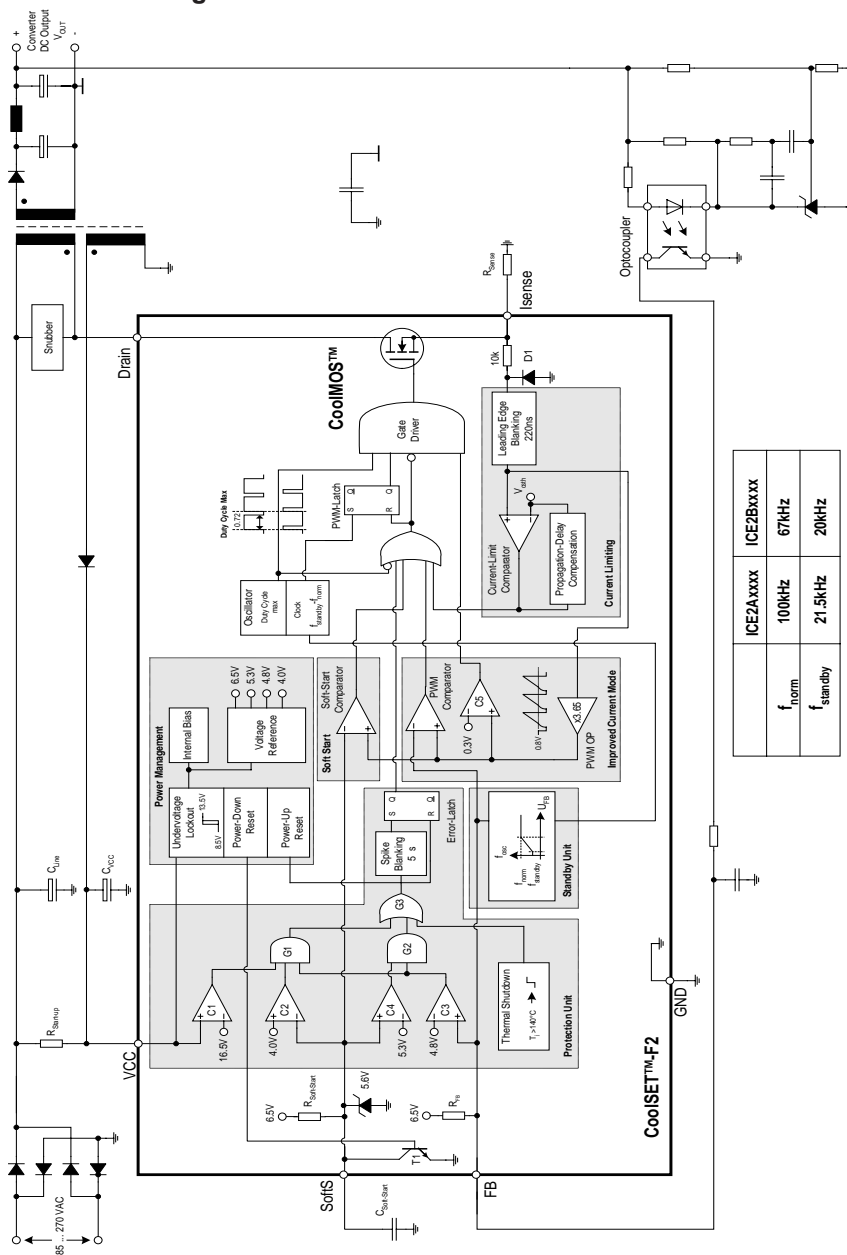

ICE2QS01 (SMPS : IC93)

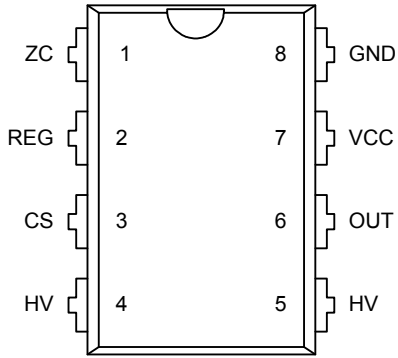

Pin	Symbol	Function
1	ZC	Zero Crossing
2	REG	Regulation
3	CS	Primary Current Sensing
4, 5	HV	High Voltage input
6	OUT	gate driver output
7	VCC	IC supply voltage
8	GND	Common ground

ICE2QS01 Block Diagram

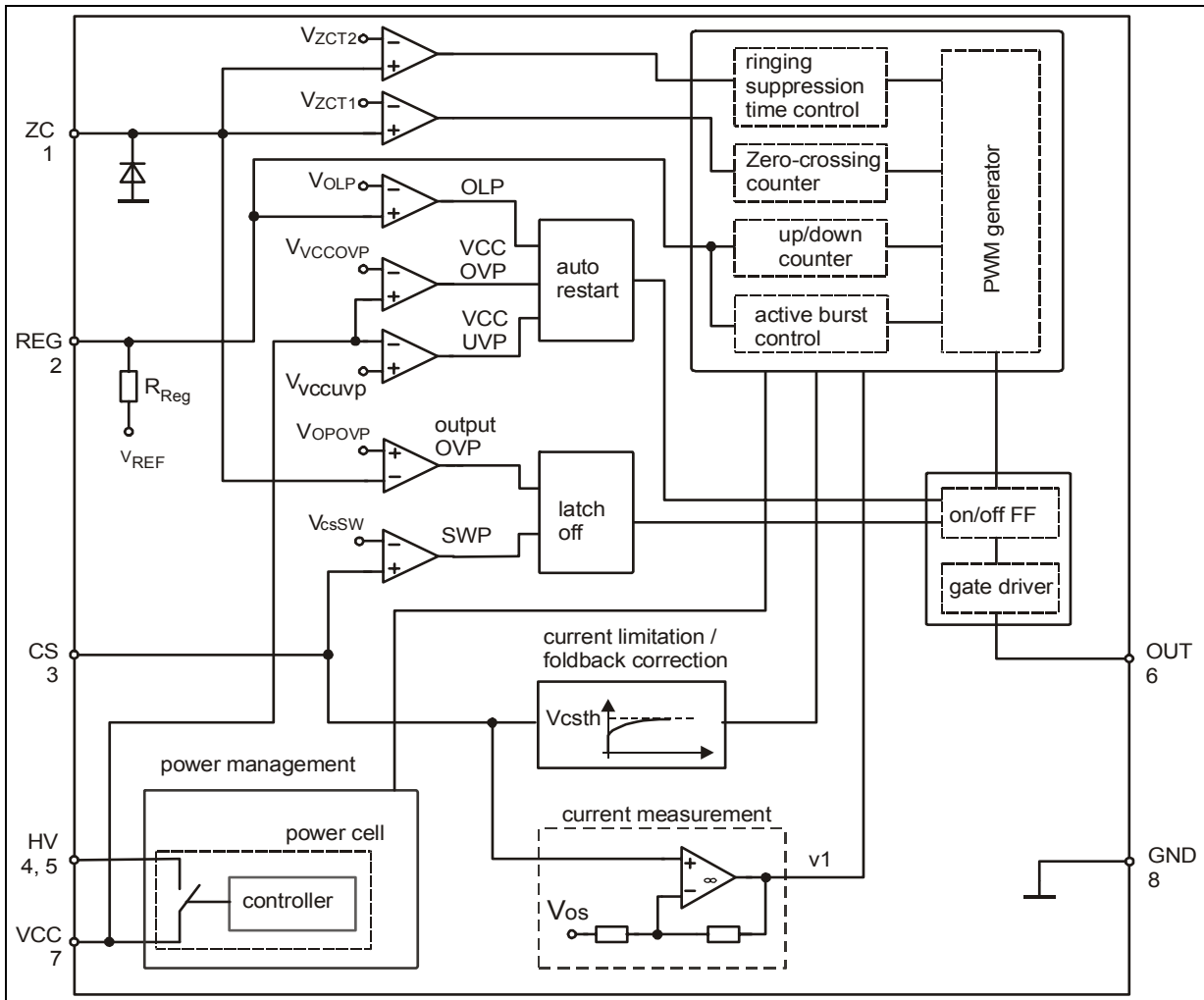

W9825G6EH-6J (ETHERNET : U3902)

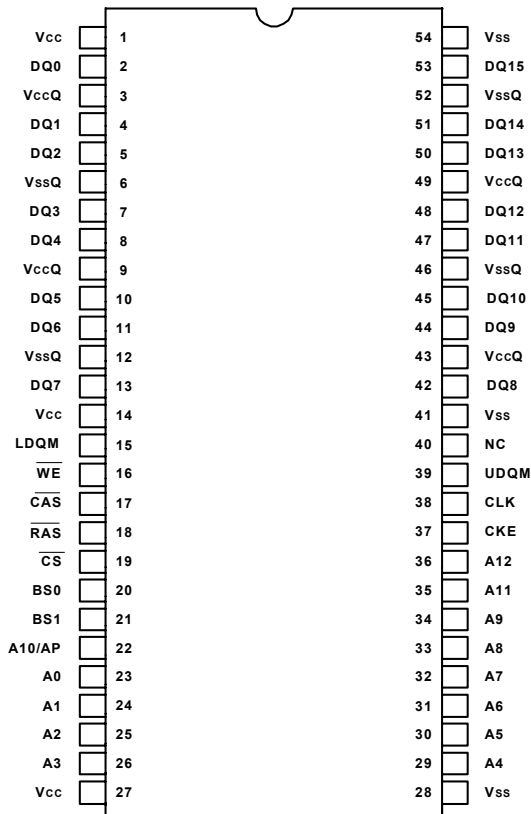

W9825G6EH-6J Block Diagram

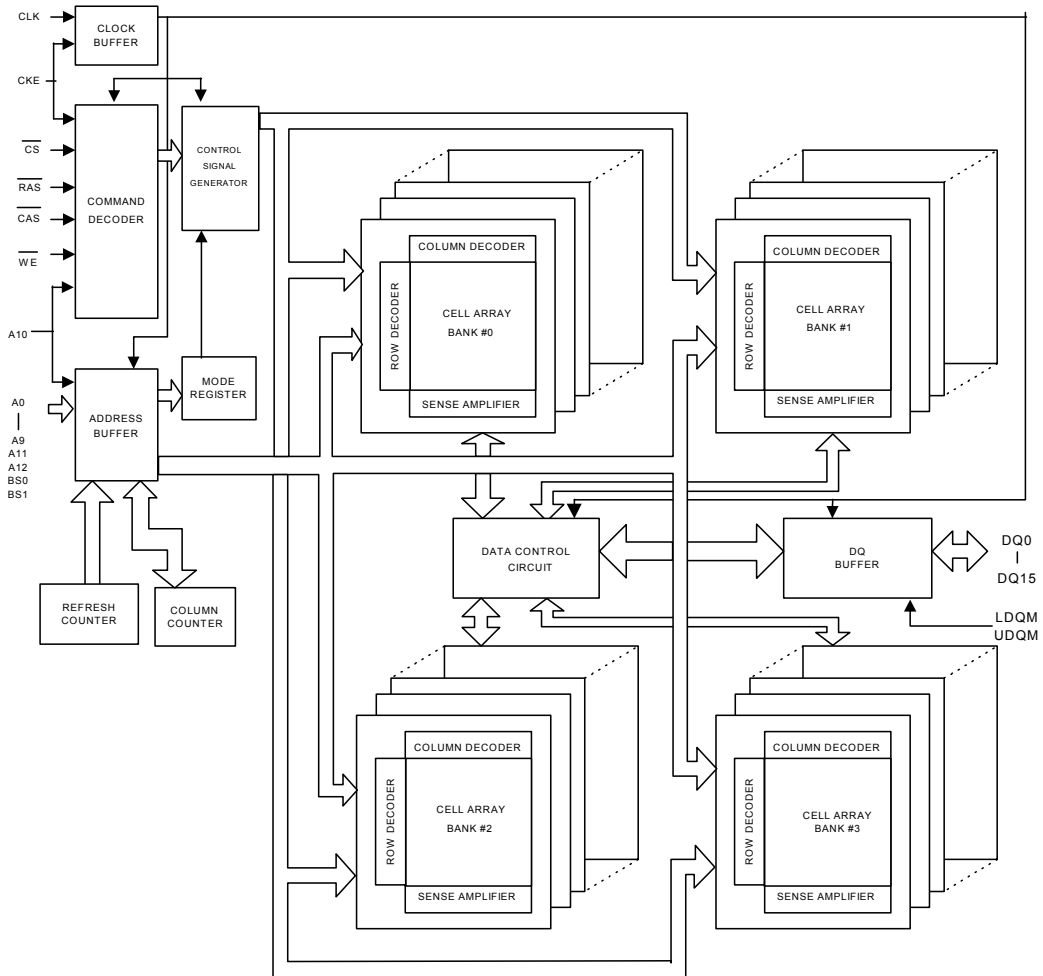

W9825G6EH-6J Pin Description

PIN NUMBER	PIN NAME	FUNCTION	DESCRIPTION
23–26, 22, 29–36	A0–A12	Address	Multiplexed pins for row and column address. Row address: A0–A12. Column address: A0–A8.
20, 21	BS0, BS1	Bank Select	Select bank to activate during row address latch time, or bank to read/write during address latch time.
2, 4, 5, 7, 8, 10, 11, 13, 42, 44, 45, 47, 48, 50, 51, 53	DQ0–DQ15	Data Input/Output	Multiplexed pins for data output and input.
19	$\overline{\text{CS}}$	Chip Select	Disable or enable the command decoder. When command decoder is disabled, new command is ignored and previous operation continues.
18	$\overline{\text{RAS}}$	Row Address Strobe	Command input. When sampled at the rising edge of the clock, $\overline{\text{RAS}}$, $\overline{\text{CAS}}$ and $\overline{\text{WE}}$ define the operation to be executed.
17	$\overline{\text{CAS}}$	Column Address Strobe	Referred to $\overline{\text{RAS}}$
16	$\overline{\text{WE}}$	Write Enable	Referred to $\overline{\text{RAS}}$
15, 39	LDQM, UDQM	Input/Output Mask	The output buffer is placed at Hi-Z(with latency of 2) when DQM is sampled high in read cycle. In write cycle, sampling DQM high will block the write operation with zero latency.
38	CLK	Clock Inputs	System clock used to sample inputs on the rising edge of clock.
37	CKE	Clock Enable	CKE controls the clock activation and deactivation. When CKE is low, Power Down mode, Suspend mode, or Self Refresh mode is entered.
1, 14, 27	VCC	Power (+3.3V)	Power for input buffers and logic circuit inside DRAM.
28, 41, 54	VSS	Ground	Ground for input buffers and logic circuit inside DRAM.
3, 9, 43, 49	VCCQ	Power (+3.3V) for I/O Buffer	Separated power from VCC, to improve DQ noise immunity.
6, 12, 46, 52	VSSQ	Ground for I/O Buffer	Separated ground from VSS, to improve DQ noise immunity.
40	NC	No Connection	No connection. (NC pin should be connected to GND or floating)

LAN8700 (HDMI : U4202)

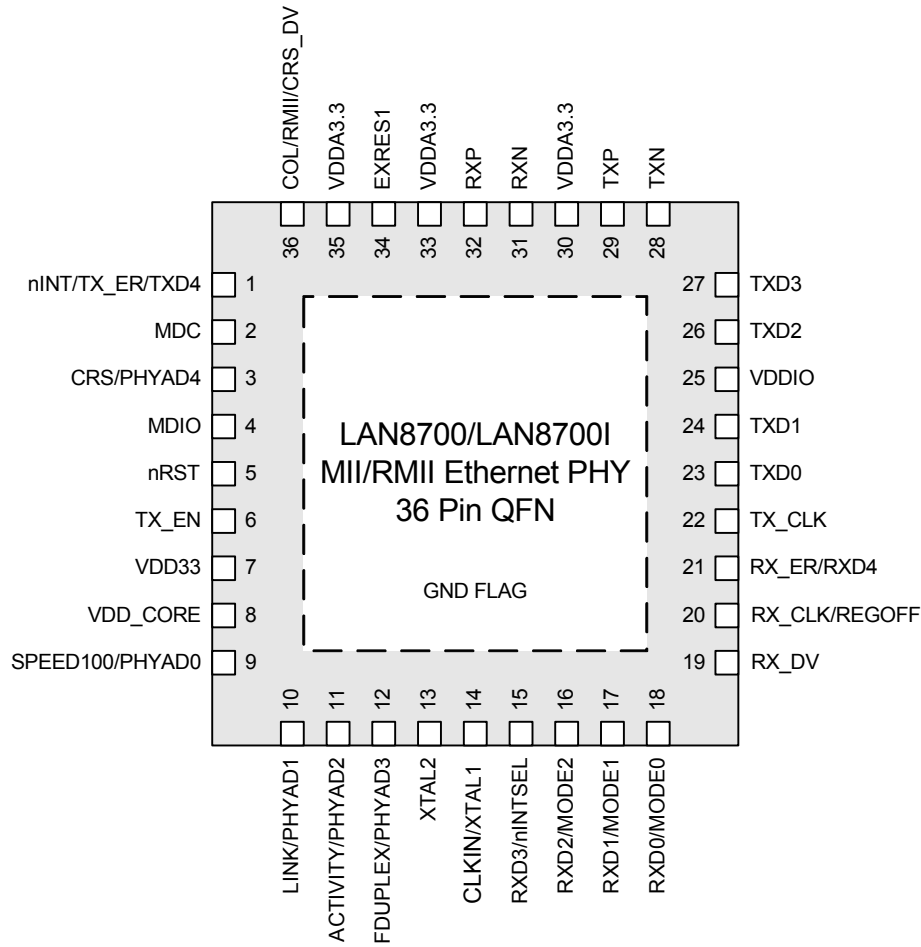

LAN8700 Block Diagram

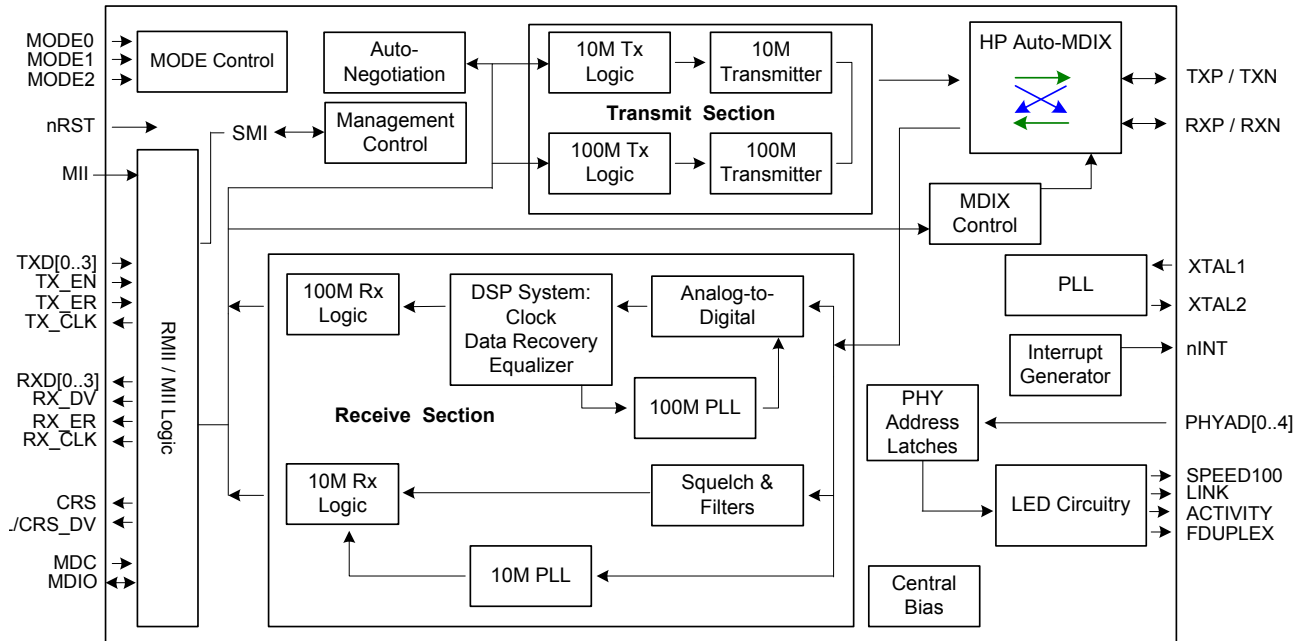

LAN8700 Pin Description

PIN NO.	PIN NAME	PIN NO.	PIN NAME
1	nINT/TX_ER/TXD4	19	RX_DV
2	MDC	20	RX_CLK/REGOFF
3	CRS/PHYAD4	21	RX_ER/RXD4
4	MDIO	22	TXCLK
5	nRST	23	TXD0
6	TX_EN	24	TXD1
7	VDD33	25	VDDIO
8	VDD_CORE	26	TXD2
9	SPEED100/PHYAD0	27	TXD3
10	LINK/PHYAD1	28	TXN
11	ACTIVITY/PHYAD2	29	TXP
12	FDUPLEX/PHYAD3	30	VDDA3.3
13	XTAL2	31	RXN
14	CLKIN/XTAL1	32	RXP
15	RXD3/nINTSEL	33	VDDA3.3
16	RXD2/MODE2	34	EXRES1
17	RXD1/MODE1	35	VDDA3.3
18	RXD0/MODE0	36	COL/RMII/CRS_DV

2. DISPLAY

MXS4003A (DISPLAY : CN84)

端子番号 Pin No.	端子名 Pin Name	入出力 IO	機能 Functions
1	VSS	P	グラウンド GND
2	NC	-	
3	VCC	P	ドライバー系陽極電源 Power supply for Anode Driver
4	VCOMH	O	ドライバー系陰極電源 Power supply for Cathode Driver
5	VLSS	P	アナロググラウンド Analog system ground
6	D7	I	データバス Data Bus
7	D6	I	データバス Data Bus
8	D5	I	データバス Data Bus
9	D4	I	データバス Data Bus
10	D3	I	データバス Data Bus
11	D2	I	データバス Data Bus
12	D1 (SDIN)	I	データバス、またはシリアルデータ入力 Data Bus or Serial Date Input
13	D0 (SCLK)	I	データバス、またはシリアルクロック入力 Data Bus or Serial Clock Input
14	E, RD#	I	読み出し (シリアルインターフェース時、内部で "L" 固定になる) Read (This pin stays "L"(low) in Serial Interface Mode)
15	R/W#, WR#	I	書き込み (シリアルインターフェース時、内部で "L" 固定になる) Write (This pin stays "L"(low) in Serial Interface Mode)
16	BS0	I	インターフェース選択子 Select MCU bus interface setting
17	BS1	I	<ul style="list-style-type: none"> ・BS0=0, BS1=0 : 4 line SPI ・BS0=1, BS1=0 : 3 line SPI ・BS0=0, BS1=1 : 8bit 8080 Parallel ・BS0=1, BS1=1 : 8bit 6800 Parallel
18	D/C#	I	データ/コマンド切替制御 "H":データ, "L":コマンド Data/Command Control. "H": Data, "L": Command
19	CS#	I	チップセレクト "L" でI/F通信可能 Chip Select, Active "L"
20	RES#	I	リセット "L" でリセット Reset, Active "L"
21	Reserved	O	NCとしてください Please No Connect.
22	IREF	O	陽極出力基準電流設定端子 Reference current setting
23	NC	-	
24	VDDIO	P	インターフェイス系電源 Power supply for Interface logic level
25	VDD	O	内部ロジック系電源 Power supply for Core logic operation
26	VCI	P	外部ロジック系電源 Low voltage power supply
27	VSL	P	陽極基準電位 Segment Reference voltage
28	VLSS	P	アナロググラウンド Analog system ground
29	NC	-	
30	VCC	P	ドライバー系陽極電源 Power supply for Anode Driver

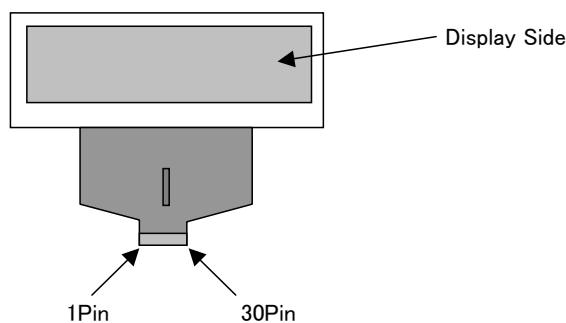

PARTS LIST OF P.C.B. UNIT

*Parts for which "nsp" is indicated on this table cannot be supplied.

*The parts listed below are for maintenance only, might differ from the parts used in the unit in appearances or dimensions.

DISPLAY PCB ASSY

Ref. No.	Part No.	Part Name	Remarks	Q'ty	New
SEMICONDUCTORS GROUP					
IC81	8R2431005500S	MCU, IC (R32C/100, 144P6Q-A)			*
IC83	943231011200S	2A Low Drop Regulator (HRP-5)			*
IC91	943239007760S	I.C , REGULATOR (3.3V, DPAK-5)			
IC92	943239008020S	I.C , REGULATOR (ADJ, DPAK-5)			
Q901-904	90M-HT300970R	T.R , CHIP	NOTE : When update Firmware, please confirm a last version in SDI. Use the service board after updating it.		
Q931	90M-HX600010R	T.R , CHIP , SOT-23			
Q932	90M-HX800010R	T.R , CHIP , SOT-23			
Q933	90M-HX600010R	T.R , CHIP , SOT-23			
Q934	90M-HX800010R	T.R , CHIP , SOT-23			
Q935	90M-HX600010R	T.R , CHIP , SOT-23			
Q936	00D2757001907	MOSFET (P-CH, 2.5V POWER TRENCH)			
Q937	90M-HX800010R	T.R , CHIP , SOT-23			
D901-903	00D2760794900	DIODE , CHIP			
D931	90M-HI101040R	L.E.D , RED			
D932	943263003130S	L.E.D , WHITE			
D937	nsp	ESD SUPPRESSOR (ASQS 12U 02 0R2, 0.2pF/12V 1005)			
D940	943263003130S	L.E.D , WHITE			
D941	nsp	DIODE , ZENER(CHIP,2.7V)			
CAPACITORS GROUP					
C801	nsp	CAP, CHIP (4.7uF/6.3V, 1608, MURATA GRM18)			
C802	nsp	CAP , CHIP (1608, 50V/1000pF)			
C805	nsp	CAP , CHIP (1608, 50V/1000pF)			
C806	nsp	CAP , CHIP (1608, 50V/0.1uF)			
C808,809	nsp	CAP, CHIP (4.7uF/6.3V, 1608, MURATA GRM18)			
C810-815	nsp	CAP , CHIP (1608, 50V/0.1uF)			
C816	nsp	CAP , CHIP (1608, 50V/33pF)			
C817	nsp	CAP , CHIP (1608, 50V/0.1uF)			
C818	nsp	CAP , CHIP (1608, 50V/0.01uF)			
C819	nsp	CAP , CHIP (1608, 50V/1000pF)			
C823	nsp	CAP , CHIP (1608, 50V/0.1uF)			
C824	nsp	CAP , CHIP (1608, 50V/0.01uF)			
C825	nsp	CAP , CHIP (1608, 50V/1000pF)			
C826	nsp	CAP , CHIP (1608, 50V/33pF)			
C827	nsp	CAP, CHIP 1UF/25V/2012/Y5V			
C828,829	nsp	CAP , CHIP (1608, 10V/1uF)			
C830	nsp	CAP , CHIP (1608, 50V/1000pF)			
C831,832	nsp	CAP , CHIP (25V/4.7uF, 2125 SIZE)			
C833	nsp	CAP , ELECT			
C834	nsp	CAP , CHIP (1608, 50V/0.1uF)			
C835	nsp	CAP , CHIP (1608, 50V/0.01uF)			
C836,837	nsp	CAP , CHIP (1608, 50V/0.1uF)			
C838	nsp	CAP , CHIP (1608, 50V/1000pF)			
C839	nsp	CAP , CHIP (1608, 50V/0.1uF)			
C840	nsp	CAP , ELECT (47uF/50V)			
C841	nsp	CAP , CHIP (1608, 50V/0.01uF)			
C842	nsp	CAP , ELECT (47uF/50V)			
C843	nsp	CAP , CHIP (1608, 50V/0.1uF)			
C844	nsp	CAP , CHIP (1608, 50V/0.01uF)			
C845	nsp	CAP , CHIP (1608, 50V/1000pF)			
C847	nsp	CAP, CHIP (1uF/25V, 2012, MURATA GRM21)			
C848	nsp	CAP , CHIP (3216, 100V/1uF)			
C849-851	nsp	CAP , CHIP (1608, 50V/0.1uF)			
C901,902	nsp	CAP , CHIP (1608, 50V/0.1uF)			
C903	nsp	CAP , CHIP (1608, 50V/0.01uF)			
C904	nsp	CAP , ELECT			
C905	nsp	CAP , CHIP (1608, 50V/0.1uF)			

Ref. No.	Part No.	Part Name	Remarks	Q'ty	New
C906	nsp	CAP , ELECT		CCEA1CKS470T	
C907	nsp	CAP , CHIP (1608, 50V/0.1uF)		CCUS1H104KC	
C908	nsp	CAP , ELECT		CCEA1AKS101T	
C909	nsp	CAP , CHIP (1608, 50V/0.01uF)		CCUS1H103KC	
C910	nsp	CAP , ELECT		CCEA1CKS101T	
C911	nsp	CAP , CHIP (1608, 50V/0.01uF)		CCUS1H103KC	
C912	nsp	CAP , ELECT		CCEA1CKS101T	
C913	nsp	CAP , CHIP (1608, 50V/0.1uF)		CCUS1H104KC	
C914	nsp	CAP , ELECT		CCEA1AKS101T	
C915	nsp	CAP , CHIP (1608, 50V/1000pF)		CCUS1H102KC	
C916	nsp	CAP , CHIP (1608, 50V/0.01uF)		CCUS1H103KC	
C917	nsp	CAP , CHIP (1608, 50V/0.1uF)		CCUS1H104KC	
C918,919	nsp	CAP , ELECT		CCEA1HKS220T	
C920,921	nsp	CAP , CHIP (1608, 50V/100pF)		CCUS1H101JA	
C931	nsp	CAP , CHIP (1608, 50V/0.1uF)		CCUS1H104KC	
C932	nsp	CAP , ELECT		CCEA1CKS470T	
C933,934	nsp	CAP , CHIP (1608, 50V/0.1uF)		CCUS1H104KC	
C941	nsp	CAP , CHIP (1608, 50V/0.1uF)		CCUS1H104KC	
C946	nsp	CAP , CHIP (1608, 50V/0.1uF)		CCUS1H104KC	
C949	nsp	CAP , CHIP (1608, 50V/0.1uF)		CCUS1H104KC	
C950,951	nsp	CAP , CHIP (1608, 50V/1000pF)		CCUS1H102KC	
C952,953	nsp	CAP , CHIP (1608, 50V/180pF)		CCUS1H181JA	
C954-956	nsp	CAP , CHIP (1608, 50V/0.1uF)		CCUS1H104KC	
C957	nsp	CAP , CHIP (1608, 50V/0.01uF)		CCUS1H103KC	
C958	nsp	CAP , CHIP (1608, 50V/0.1uF)		CCUS1H104KC	
C959	nsp	CAP , ELECT		CCEA1AKS221T	
C964	nsp	CAP , CHIP (1608, 50V/0.1uF)		CCUS1H104KC	
C965	nsp	CAP , CHIP (1608, 50V/0.01uF)		CCUS1H103KC	
C966	nsp	CAP , CHIP (1608, 50V/1000pF)		CCUS1H102KC	
C967	nsp	CAP , CHIP (1608, 50V/0.1uF)		CCUS1H104KC	
C968,969	nsp	CAP , CHIP (1608, 50V/0.01uF)		CCUS1H103KC	
C970	nsp	CAP , CHIP (1608, 50V/0.1uF)		CCUS1H104KC	
C971	nsp	CAP , CHIP (1608, 50V/0.01uF)		CCUS1H103KC	
C972	nsp	CAP , CHIP (1608, 50V/1000pF)		CCUS1H102KC	
C973	nsp	CAP , CHIP (1608, 50V/0.1uF)		CCUS1H104KC	
C974	nsp	CAP , CHIP (1608, 50V/0.01uF)		CCUS1H103KC	
C975	nsp	CAP , CHIP (1608, 50V/1000pF)		CCUS1H102KC	
C976	nsp	CAP , CHIP (1608, 50V/0.1uF)		CCUS1H104KC	
C977	nsp	CAP , CHIP (1608, 50V/0.01uF)		CCUS1H103KC	
C978	nsp	CAP , CHIP (1608, 50V/1000pF)		CCUS1H102KC	
C979,980	nsp	CAP , CHIP (1608, 50V/0.1uF)		CCUS1H104KC	
C985	nsp	CAP , CHIP (1608, 50V/0.1uF)		CCUS1H104KC	
C989-993	nsp	CAP , CHIP (1608, 50V/0.1uF)		CCUS1H104KC	
C994-996	nsp	CAP , CHIP (1608, 50V/0.01uF)		CCUS1H103KC	
C997-999	nsp	CAP , CHIP (1608, 50V/1000pF)		CCUS1H102KC	
OTHER PATRS GROUP					
BN81	nsp	WIRE ASS'Y (SHIELD, 7P, 2MM, 200MM)		CWB1C90720047001	
BN82	nsp	WIRE ASS'Y (SHIELD, 5P, 2MM, 400MM)		CWB1C905400NG003	
BR91,92	nsp	BRACKET , PCB		CMD1A569	
CN84	nsp	WAFER, SMD (30P, 0.5mm, FRONT FLIP)		CJP30GB278ZY	
CN87	nsp	WAFER , CARD CABLE (10008HR-NNL1mm PITCH, ANGLE)		CJP11GB210ZY	
CN88	nsp	WAFER, STRSIGHT, 1MM, SMD		CJP30GA193ZY	
CN91	nsp	WAFER , CARD CABLE		CJP11GB113ZY	
CN92	nsp	2.54mm 30PIN WAFER		CJP30GA221ZB	
JK81	943643001320S	JACK , USB STRAIGHT(BLACK)		CJJ9X006Z	
JK83,84	90M-YT004320R	JACK , HEADPHONE		HJJ2D003Z	
L801,802	nsp	BEAD , FERRITE (FCM2012KF-121T08 , 120 OHM)		CLZ9R010Z	
L802	nsp	BEAD , FERRITE (FCM2012KF-121T08 , 120 OHM)		CLZ9R010Z	
L901-903	nsp	FERRITE , CHIP BEAD(220ohm, 2012)		CLZ9R006Z	
L904-907	nsp	CHIP , BEAD		HLZ9Z014Z	
L931	nsp	FERRITE , CHIP BEAD(220ohm, 2012)		CLZ9R006Z	

Ref. No.	Part No.	Part Name	Remarks		Q'ty	New
L932	nsp	RES , CHIP , 0 OHM, 5% , 1/8W , 2012		CRJ18AJ0R0T		
RC81	00MHW10004210	SENSOR , REMOCON		CRVRPM6936V4		
S901-915	90M-SP001210R	SW , TACT		CST1A012ZT		
X802	943142011280S	16M Resonator		COXCSTCE16M0V51		*

MAIN PCB ASS'Y

Ref. No.	Part No.	Part Name	Remarks	Q'ty	New
SEMICONDUCTORS GROUP					
IC11	8R2431005400S	MCU, IC (R32C/100, 144P6Q-A)		CVIR5F64169DFD	*
IC12	943231011000S	I,C , REGULATOR(3.3V SMD Type)		BVIBA33BC0FP	
IC13	943231011210S	I.C , REGULATOR (SWITCH LOW DROP,5V,DPAK-5)		CVIKIA78R050F	*
IC18	90M-HC900160R	I.C , REGULATOR(SOT-223)		CVIKIA1117S15	
IC21	943245006980S	I.C , CD DSP (SERVO,AMPLIFIER,DSP,LQFP-80P)		CVITC94A92FG	
IC22	943249011290S	I.C EEPROM(256K, 32-kword x 8 bit)		CVIR1EX24256ASAS0A	*
IC25	943239011300S	Reset IC (3V, SSOP5)		CVIBD4730G	*
IC26	943231011220S	I.C , REGULATOR (9V, DPAK-5)		CVIKIA78R09F	*
IC31	943239006900S	I.C , 5-CH MOTOR DRIVE IC (WITH REG,SSOP-28P)		CVIIP4001CRLTF	
IC32	943231011210S	I.C , REGULATOR (SWITCH LOW DROP,5V,DPAK-5)		CVIKIA78R050F	*
IC41	00D2623762008	I.C , AUDIO CODEC(64PIN_LQFP, 0.5MM)		CVIAK4683EQ	
IC42,43	00MHC008005K0	I.C , INVERTER(CMOS)	<div style="border: 1px solid black; border-radius: 10px; padding: 5px; width: fit-content;"> NOTE : When update Firmware, please confirm a last version in SDI. Use the service board after updating it. </div>	CVITC7WHU04FU	
IC44	00MHC10102090	I.C , OP AMP (JRC)		HVINJM2068MDTE1	
IC51	00MHC12273370	I.C , PWM PROCESSOR		CVITAS5508BPAG	
IC52	00MHC10102090	I.C , OP AMP (JRC)		HVINJM2068MDTE1	
IC53	00MHC10200090	I.C , HEADPHONE (JRC)		HVINJM4556AL	
IC63	00MHC10102090	I.C , OP AMP (JRC)		HVINJM2068MDTE1	
IC64	90M-HC900150R	I.C , REGULATOR(SOT-223)		CVIKIA1117S33	
IC71,72	00D2623503911	I.C , STEREO DIGITAL AMP		CVITAS5142DKDG4	
Q201	90M-HX600020R	T.R , CHIP		HVTKTA1504SYRTK	
Q202	90M-HX800010R	T.R , CHIP , SOT-23		HVTKRC102S	
Q203	90M-BA001600R	T.R , CHIP , SOT-23		HVTKRA107S	
Q204	90M-HX800100R	T.R , CHIP		HVTKTC3875SYRTK	
Q235,236	90M-HX800010R	T.R , CHIP , SOT-23		HVTKRC102S	
Q237	90M-BA001600R	T.R , CHIP , SOT-23		HVTKRA107S	
Q238	90M-HX800080R	T.R , CHIP , SOT-23		HVTKRC107S	
Q240	90M-HX800010R	T.R , CHIP , SOT-23		HVTKRC102S	
Q251,252	90M-HX800010R	T.R , CHIP , SOT-23		HVTKRC102S	
Q256	90M-HX800010R	T.R , CHIP , SOT-23		HVTKRC102S	
Q301	90M-HX800100R	T.R , CHIP		HVTKTC3875SYRTK	
Q303	90M-HX800010R	T.R , CHIP , SOT-23		HVTKRC102S	
Q311	90M-HX600010R	T.R , CHIP , SOT-23		HVTKRA102S	
Q312	90M-HX800010R	T.R , CHIP , SOT-23		HVTKRC102S	
Q404-407	90M-HT300970R	T.R , CHIP		HVTKTC2875B	
Q501	90M-HX800080R	T.R , CHIP , SOT-23		HVTKRC107S	
Q502	90M-BA001600R	T.R , CHIP , SOT-23		HVTKRA107S	
Q503	90M-HX800080R	T.R , CHIP , SOT-23		HVTKRC107S	
Q504	90M-BA001600R	T.R , CHIP , SOT-23		HVTKRA107S	
Q601	90M-HX800080R	T.R , CHIP , SOT-23		HVTKRC107S	
Q608,609	90M-HT800110R	T.R , CHIP		HVTKTC4075GR	
Q610-615	90M-HT300970R	T.R , CHIP		HVTKTC2875B	
Q616	90M-HX800010R	T.R , CHIP , SOT-23		HVTKRC102S	
Q617	90M-HX600010R	T.R , CHIP , SOT-23		HVTKRA102S	
Q618	90M-HX800010R	T.R , CHIP , SOT-23		HVTKRC102S	
Q622	90M-HX800010R	T.R , CHIP , SOT-23		HVTKRC102S	
Q623	90M-HX600010R	T.R , CHIP , SOT-23		HVTKRA102S	
Q624	90M-HX800010R	T.R , CHIP , SOT-23		HVTKRC102S	
Q701	90M-HX800080R	T.R , CHIP , SOT-23		HVTKRC107S	
Q702	90M-BA001600R	T.R , CHIP , SOT-23		HVTKRA107S	
Q705	90M-HX600020R	T.R , CHIP		HVTKTA1504SYRTK	
Q706	90M-HX800100R	T.R , CHIP		HVTKTC3875SYRTK	
Q707	90M-HX600020R	T.R , CHIP		HVTKTA1504SYRTK	
Q708	90M-HX800100R	T.R , CHIP		HVTKTC3875SYRTK	
Q751	90M-HX800080R	T.R , CHIP , SOT-23		HVTKRC107S	
Q752	90M-BA001600R	T.R , CHIP , SOT-23		HVTKRA107S	
D103	00D2760794900	DIODE , CHIP		CVDKDS160RTKP	
D201	00MHZ21303210	DIODE , CHIP		HVD1SS355T	
D202-204	00D2760794900	DIODE , CHIP		CVDKDS160RTKP	
D207	nsp	DIODE , RECT		CVD1N4003T	
D208-211	00MHZ21303210	DIODE , CHIP		HVD1SS355T	
D214,215	00MHZ21303210	DIODE , CHIP		HVD1SS355T	
D230	nsp	DIODE , ZENER		HVDMTZJ16BT	

Ref. No.	Part No.	Part Name	Remarks	Q'ty	New
D231	nsp	DIODE , ZENER			
D232	nsp	DIODE , ZENER			
D233	nsp	DIODE , ZENER			
D234	nsp	DIODE , ZENER			
D235	nsp	DIODE , ZENER			
D238,239	00D2760794900	DIODE , CHIP			
D240	nsp	DIODE , ZENER			
D241	nsp	DIODE , ZENER			
D251-255	00MHZ21303210	DIODE , CHIP			
D262,263	00MHZ21303210	DIODE , CHIP			
D302	00D2760794900	DIODE , CHIP			
D401,402	00D2760794900	DIODE , CHIP			
D501-504	00MHZ21303210	DIODE , CHIP			
D605,606	00MHZ21303210	DIODE , CHIP			
D607,608	00D2760794900	DIODE , CHIP			
D609	00MHZ21303210	DIODE , CHIP			
D612,613	00D2760794900	DIODE , CHIP			
D615,616	00D2760794900	DIODE , CHIP			
CAPACITORS GROUP					
C131	nsp	CAP , CHIP (1608, 50V/0.01uF)			
C143	nsp	CAP , ELECT			
C144	nsp	CAP , CHIP (1608, 50V/0.1uF)			
C145	nsp	CAP , ELECT			
C146	nsp	CAP , CHIP (1608, 50V/0.1uF)			
C174	nsp	CAP , ELECT			
C175	nsp	CAP , CHIP (1608, 50V/0.1uF)			
C176	nsp	CAP , CHIP (1608, 50V/1000pF)			
C177	nsp	CAP , ELECT			
C178	nsp	CAP , CHIP (1608, 50V/0.1uF)			
C180	nsp	CAP , CHIP (1608, 50V/1000pF)			
C185	nsp	CAP , ELECT			
C186	nsp	CAP , CHIP (1608, 50V/0.1uF)			
C187	nsp	CAP , CHIP (1608, 50V/1000pF)			
C188	nsp	CAP , CHIP (1608, 50V/0.1uF)			
C189	nsp	CAP , ELECT			
C190	nsp	CAP , CHIP (1608, 50V/0.1uF)			
C191	nsp	CAP , CHIP (1608, 50V/1000pF)			
C201	nsp	CAP , CHIP (1608, 50V/0.1uF)			
C202	nsp	CAP , CHIP (1608, 50V/2200pF)			
C203	nsp	CAP , CHIP (1608, 50V/0.01uF)			
C204	nsp	CAP , CHIP (1608, 50V/4700pF)			
C205	nsp	CAP , CHIP (1608, 50V/0.1uF)			
C206	nsp	CAP , CHIP (1608, 50V/0.015uF)			
C207	nsp	CAP , CHIP (1608, 50V/0.1uF)			
C209	nsp	CAP , CHIP (1608, 50V/0.1uF)			
C210	nsp	CAP , CHIP ELECT			
C211	nsp	CAP , CHIP (1608, 50V/0.033uF)			
C212	nsp	CAP , CHIP (1608, 50V/5600pF)			
C213	nsp	CAP , CHIP (1608, 50V/0.1uF)			
C214,215	nsp	CAP , CHIP (1608, 50V/470pF)			
C216	nsp	CAP , CHIP ELECT			
C217	nsp	CAP , CHIP (1608, 50V/0.01uF)			
C219,220	nsp	CAP , CHIP (1608, 50V/0.047uF)			
C221	nsp	CAP , CHIP (1608, 50V/0.1uF)			
C224	nsp	CAP , CHIP (1608, 50V/0.1uF)			
C225	nsp	CAP , CHIP (1608, 50V/15pF)			
C226	nsp	CAP , CHIP (1608, 50V/18pF)			
C227	nsp	CAP , CHIP (1608, 50V/0.1uF)			
C228	nsp	CAP , ELECT			
C229-231	nsp	CAP , CHIP (1608, 50V/0.1uF)			
C232	nsp	CAP , CHIP (1608, 50V/1000pF)			
C233	nsp	CAP , CHIP (1608, 50V/0.1uF)			
C234,235	nsp	CAP , CHIP (1608, 50V/1000pF)			
C237	nsp	CAP , CHIP (1608, 50V/0.1uF)			
C238	nsp	CAP , CHIP (1608, 50V/0.015uF)			

Ref. No.	Part No.	Part Name	Remarks	Q'ty	New
C239	nsp	CAP , ELECT		CCEA1AKS101T	
C240	nsp	CAP , CHIP (1608, 50V/0.1uF)		CCUS1H104KC	
C241	nsp	CAP , CHIP (1608, 50V/47pF)		CCUS1H470JA	
C242	nsp	CAP , CHIP (1608, 50V/0.1uF)		CCUS1H104KC	
C243	nsp	CAP , ELECT		CCEA1AKS470T	
C244	nsp	CAP , CHIP (1608, 50V/0.01uF)		CCUS1H103KC	
C245	nsp	CAP , CHIP (1608, 50V/1000pF)		CCUS1H102KC	
C246	nsp	CAP , CHIP (1608, 50V/0.1uF)		CCUS1H104KC	
C247,248	nsp	CAP , CHIP(2012 SIZE)		CCUC1A475ZF	
C251	nsp	CAP , CHIP (1608, 50V/0.1uF)		CCUS1H104KC	
C252	nsp	CAP , ELECT		CCEA1AKS101T	
C253	nsp	CAP , ELECT		CCEA1CH471T	
C254	nsp	CAP , CHIP (1608, 50V/0.1uF)		CCUS1H104KC	
C255	nsp	CAP , ELECT		CCEA1CH471T	
C256,257	nsp	CAP , CHIP (1608, 50V/0.1uF)		CCUS1H104KC	
C258	nsp	CAP , CHIP (1608, 50V/0.01uF)		CCUS1H103KC	
C259	nsp	CAP , CHIP (1608, 50V/1000pF)		CCUS1H102KC	
C260-263	nsp	CAP , CHIP (1608, 50V/0.1uF)		CCUS1H104KC	
C264,265	nsp	CAP , ELECT		CCEA1CH101T	
C266	nsp	CAP , CHIP (1608, 50V/0.1uF)		CCUS1H104KC	
C270	nsp	CAP , CHIP(2012 SIZE)		CCUC1A475ZF	
C271	nsp	CAP , ELECT		CCEA1HH100T	
C272	nsp	CAP , CHIP(2012 SIZE)		CCUC1A475ZF	
C274	nsp	CAP , CHIP (1608, 50V/1000pF)		CCUS1H102KC	
C275	nsp	CAP , CHIP (1608, 50V/0.01uF)		CCUS1H103KC	
C276	nsp	CAP , CHIP (1608, 50V/0.1uF)		CCUS1H104KC	
C278	nsp	CAP , CHIP (1608, 50V/0.1uF)		CCUS1H104KC	
C279	nsp	CAP , ELECT		CCEA1CH101T	
C280	nsp	CAP , CHIP (1608, 50V/1000pF)		CCUS1H102KC	
C285	nsp	CAP , ELECT		CCEA1CH101T	
C286	nsp	CAP , CHIP (1608, 50V/0.1uF)		CCUS1H104KC	
C291	nsp	CAP , ELECT		CCEA1CKS101T	
C292	nsp	CAP , CHIP (1608, 50V/0.1uF)		CCUS1H104KC	
C293	nsp	CAP , ELECT		CCEA1CKS101T	
C294	nsp	CAP , CHIP (1608, 50V/0.1uF)		CCUS1H104KC	
C304	nsp	CAP , CHIP (1608, 50V/0.1uF)		CCUS1H104KC	
C306	nsp	CAP , CHIP (1608, 50V/0.1uF)		CCUS1H104KC	
C307	nsp	CAP , ELECT		CCEA1CH471T	
C308	nsp	CAP , SMD ELECT(MANLEX RV, 16V/470, 10X10)		CCEC1CRV471T	
C309	nsp	CAP , CHIP (1608, 50V/0.1uF)		CCUS1H104KC	
C310	nsp	CAP , ELECT		CCEA1AH101T	
C311	nsp	CAP , CHIP (1608, 50V/0.1uF)		CCUS1H104KC	
C315	nsp	CAP , CHIP (1608, 50V/1000pF)		CCUS1H102KC	
C316	nsp	CAP , CHIP (1608, 50V/0.01uF)		CCUS1H103KC	
C317,318	nsp	CAP , CHIP (1608, 50V/0.1uF)		CCUS1H104KC	
C319	nsp	CAP , ELECT		CCEA1CH470T	
C320	nsp	CAP , CHIP (1608, 50V/0.01uF)		CCUS1H103KC	
C321	nsp	CAP , ELECT		CCEA1CH101T	
C322	nsp	CAP , CHIP (1608, 50V/0.01uF)		CCUS1H103KC	
C323	nsp	CAP , ELECT		CCEA1EH101T	
C331,332	nsp	CAP , CHIP (1608, 50V/1000pF)		CCUS1H102KC	
C334,335	nsp	CAP , CHIP (1608, 50V/0.1uF)		CCUS1H104KC	
C346	nsp	CAP , CHIP (1608, 50V/1000pF)		CCUS1H102KC	
C347	nsp	CAP , CHIP (1608, 50V/0.01uF)		CCUS1H103KC	
C348	nsp	CAP , CHIP (1608, 50V/0.1uF)		CCUS1H104KC	
C349	nsp	CAP , ELECT		CCEA1CH101T	
C350	nsp	CAP , CHIP (1608, 50V/2200pF)		CCUS1H222KC	
C351	nsp	CAP , ELECT		CCEA1CH470T	
C352-355	nsp	CAP , CHIP (1608, 50V/0.1uF)		CCUS1H104KC	
C389	nsp	CAP , CHIP(2012 SIZE)		CCUC1A475ZF	
C392	nsp	CAP , CHIP (1608, 50V/1000pF)		CCUS1H102KC	
C401	nsp	CAP , ELECT		CCEA1EH101T	
C402	nsp	CAP , CHIP (1608, 50V/0.1uF)		CCUS1H104KC	
C403	nsp	CAP , ELECT		CCEA1EH101T	
C404	nsp	CAP , CHIP (1608, 50V/0.1uF)		CCUS1H104KC	
C405	nsp	CAP , CHIP (1608, 50V/47pF)		CCUS1H470JA	
C406	nsp	CAP , CHIP (1608, 50V/56pF)		CCUS1H560JA	

Ref. No.	Part No.	Part Name	Remarks		Q'ty	New
C407	nsp	CAP , CHIP (1608, 50V/0.01uF)			CCUS1H103KC	
C409	nsp	CAP , CHIP (1608, 50V/0.1uF)			CCUS1H104KC	
C410	nsp	CAP , ELECT			CCEA1HH100T	
C411	nsp	CAP , ELECT			CCEA1HH1R0T	
C412	nsp	CAP , CHIP (1608, 50V/0.1uF)			CCUS1H104KC	
C413	nsp	CAP , ELECT			CCEA1HH2R2T	
C414	nsp	CAP , CHIP (1608, 50V/0.1uF)			CCUS1H104KC	
C415	nsp	CAP , ELECT			CCEA1HH100T	
C416	nsp	CAP , CHIP (1608, 50V/0.1uF)			CCUS1H104KC	
C417	00D2544692901	CE04W1J100MT(RFO)			CCEA1HH100T	
C418-429	nsp	CAP , ELECT			CCEA1HH1R0T	
C430	nsp	CAP , CHIP (1608, 50V/0.1uF)			CCUS1H104KC	
C431	nsp	CAP , ELECT			CCEA1HH100T	
C432,433	nsp	CAP , ELECT			CCEA1HH220T	
C434	nsp	CAP , ELECT			CCEA1EH470T	
C435	nsp	CAP , CHIP (1608, 50V/0.1uF)			CCUS1H104KC	
C436,437	nsp	CAP , CHIP (1608, 50V/330pF)			CCUS1H331JA	
C438	nsp	CAP , ELECT			CCEA1EH470T	
C439	nsp	CAP , CHIP (1608, 50V/0.1uF)			CCUS1H104KC	
C440,441	nsp	CAP , CHIP (1608, 50V/0.01uF)			CCUS1H103KC	
C442,443	nsp	CAP , ELECT			CCEA1HH220T	
C447-450	nsp	CAP , CHIP (1608, 50V/100pF)			CCUS1H101JA	
C453,454	nsp	CAP , CHIP (1608, 50V/100pF)			CCUS1H101JA	
C458	nsp	CAP , ELECT			CCEA1EH470T	
C459	nsp	CAP , CHIP (1608, 50V/0.1uF)			CCUS1H104KC	
C460-463	nsp	CAP , CHIP (1608, 50V/100pF)			CCUS1H101JA	
C464	nsp	CAP , CHIP (1608, 50V/0.1uF)			CCUS1H104KC	
C465	nsp	CAP , ELECT			CCEA1EH470T	
C466-469	nsp	CAP , CHIP (1608, 50V/270pF)			CCUS1H271JA	
C470,471	nsp	CAP , ELECT			CCEA1HH100T	
C472,473	nsp	CAP , CHIP (1608, 50V/100pF)			CCUS1H101JA	
C477	nsp	CAP , ELECT			CCEA1CH470T	
C478,479	nsp	CAP , CHIP (1608, 50V/0.01uF)			CCUS1H103KC	
C480	nsp	CAP , CHIP (1608, 50V/4700pF)			CCUS1H472KC	
C481,482	nsp	CAP , CHIP (1608, 10V/1uF)			CCUS1A105KC	
C483	nsp	CAP , ELECT			CCEA1EH470T	
C484	nsp	CAP , CHIP (1608, 50V/0.1uF)			CCUS1H104KC	
C485	nsp	CAP , ELECT			CCEA1EH470T	
C486,487	nsp	CAP , CHIP (1608, 50V/0.1uF)			CCUS1H104KC	
C488	nsp	CAP , CHIP (1608, 50V/100pF)			CCUS1H101JA	
C489,490	nsp	CAP , CHIP (1608, 50V/0.1uF)			CCUS1H104KC	
C491	nsp	CAP , ELECT			CCEA1EH470T	
C492,493	nsp	CAP , CHIP (1608, 50V/0.1uF)			CCUS1H104KC	
C494	nsp	CAP , ELECT			CCEA1EH470T	
C495,496	nsp	CAP , CHIP (1608, 50V/0.1uF)			CCUS1H104KC	
C497,498	nsp	CAP , CHIP (1608, 50V/100pF)			CCUS1H101JA	
C499,500	nsp	CAP , ELECT			CCEA1HH100T	
C501	nsp	CAP , CHIP (1608, 50V/0.1uF)			CCUS1H104KC	
C502	nsp	CAP , CHIP (1608, 50V/0.01uF)			CCUS1H103KC	
C503,504	nsp	CAP , CHIP (1608, 50V/0.1uF)			CCUS1H104KC	
C505	nsp	CAP , CHIP (1608, 50V/0.01uF)			CCUS1H103KC	
C506,507	nsp	CAP , CHIP (1608, 50V/0.1uF)			CCUS1H104KC	
C508	nsp	CAP , ELECT			CCEA1HH100T	
C509	nsp	CAP , CHIP (1608, 50V/1000pF)			CCUS1H102KC	
C510	nsp	CAP , CHIP (1608, 50V/0.1uF)			CCUS1H104KC	
C511	nsp	CAP , ELECT			CCEA1HH100T	
C512-517	nsp	CAP , CHIP (1608, 50V/0.1uF)			CCUS1H104KC	
C518	nsp	CAP , CHIP (1608, 50V/22pF)			CCUS1H220JA	
C519	nsp	CAP , CHIP (1608, 50V/18pF)			CCUS1H180JA	
C520,521	nsp	CAP , CHIP (1608, 50V/0.1uF)			CCUS1H104KC	
C522	nsp	CAP , ELECT			CCEA1HH100T	
C523,524	nsp	CAP , CHIP (1608, 50V/0.1uF)			CCUS1H104KC	
C525	nsp	CAP , ELECT			CCEA1CH101T	
C526	nsp	CAP , CHIP (1608, 50V/0.1uF)			CCUS1H104KC	
C527	nsp	CAP , ELECT			CCEA1EH470T	
C528	nsp	CAP , CHIP (1608, 50V/0.1uF)			CCUS1H104KC	
C531	nsp	CAP , CHIP (1608, 50V/0.1uF)			CCUS1H104KC	

Ref. No.	Part No.	Part Name	Remarks	Q'ty	New
C532	nsp	CAP , ELECT		CCEA1EH470T	
C535,536	nsp	CAP , ELECT		CCEA1HH100T	
C537,538	nsp	CAP , CHIP (1608, 50V/100pF)		CCUS1H101JA	
C539-543	nsp	RES , CHIP(0 OHM , 5% , 1608)		CRJ10DJ0R0T	
C550	nsp	RES , CHIP(0 OHM , 5% , 1608)		CRJ10DJ0R0T	
C553-555	nsp	RES , CHIP(0 OHM , 5% , 1608)		CRJ10DJ0R0T	
C557	nsp	CAP , ELECT		CCEA1HH100T	
C558,559	nsp	CAP , CHIP (1608, 50V/0.1uF)		CCUS1H104KC	
C560	nsp	CAP , ELECT		CCEA1HH100T	
C561	nsp	RES , CHIP(0 OHM , 5% , 1608)		CRJ10DJ0R0T	
C567	nsp	CAP , CHIP (1608, 50V/0.1uF)		CCUS1H104KC	
C571-573	nsp	CAP , CHIP (1608, 50V/1000pF)		CCUS1H102KC	
C574,575	nsp	CAP , ELECT		CCEA1EH221T	
C580	nsp	CAP , CHIP (1608, 50V/0.1uF)		CCUS1H104KC	
C580-582	nsp	RES , CHIP(0 OHM , 5% , 1608)		CRJ10DJ0R0T	
C587	nsp	RES , CHIP(0 OHM , 5% , 1608)		CRJ10DJ0R0T	
C591	nsp	RES , CHIP(0 OHM , 5% , 1608)		CRJ10DJ0R0T	
C596	nsp	RES , CHIP(0 OHM , 5% , 1608)		CRJ10DJ0R0T	
C601	nsp	CAP , CHIP (1608, 50V/0.1uF)		CCUS1H104KC	
C602	nsp	CAP , CHIP (1608, 50V/0.01uF)		CCUS1H103KC	
C603	nsp	CAP , CHIP (1608, 50V/1000pF)		CCUS1H102KC	
C604	nsp	CAP , CHIP (1608, 50V/0.1uF)		CCUS1H104KC	
C605	nsp	CAP , CHIP (1608, 50V/0.01uF)		CCUS1H103KC	
C606	nsp	CAP , CHIP (1608, 50V/1000pF)		CCUS1H102KC	
C607,608	nsp	CAP , ELECT		CCEA1EH221T	
C656	nsp	CAP , CHIP (1608, 50V/0.1uF)		CCUS1H104KC	
C658	nsp	CAP , CHIP (1608, 50V/0.01uF)		CCUS1H103KC	
C659	nsp	CAP , CHIP (1608, 50V/0.1uF)		CCUS1H104KC	
C661	nsp	CAP , CHIP (1608, 50V/0.1uF)		CCUS1H104KC	
C662	nsp	CAP , CHIP (1608, 50V/0.01uF)		CCUS1H103KC	
C663	nsp	CAP , CHIP (1608, 50V/1000pF)		CCUS1H102KC	
C664	nsp	CAP , CHIP (1608, 50V/0.1uF)		CCUS1H104KC	
C665	nsp	CAP , CHIP (1608, 50V/0.01uF)		CCUS1H103KC	
C666	nsp	CAP , CHIP (1608, 50V/1000pF)		CCUS1H102KC	
C667	nsp	CAP , CHIP (1608, 50V/0.1uF)		CCUS1H104KC	
C680	nsp	CAP , CHIP (1608, 50V/0.01uF)		CCUS1H103KC	
C681	nsp	CAP , CHIP (1608, 50V/1000pF)		CCUS1H102KC	
C682	nsp	CAP , CHIP (1608, 50V/0.1uF)		CCUS1H104KC	
C683	nsp	CAP , CHIP (1608, 50V/0.01uF)		CCUS1H103KC	
C684	nsp	CAP , CHIP (1608, 50V/1000pF)		CCUS1H102KC	
C685	nsp	CAP , CHIP (1608, 50V/0.1uF)		CCUS1H104KC	
C686	nsp	CAP , CHIP (1608, 50V/0.01uF)		CCUS1H103KC	
C687	nsp	CAP , CHIP (1608, 50V/1000pF)		CCUS1H102KC	
C688	nsp	CAP , CHIP (1608, 50V/0.1uF)		CCUS1H104KC	
C689	nsp	CAP , CHIP (1608, 50V/0.01uF)		CCUS1H103KC	
C690	nsp	CAP , CHIP (1608, 50V/1000pF)		CCUS1H102KC	
C691	nsp	CAP , CHIP (1608, 50V/0.01uF)		CCUS1H103KC	
C692	nsp	CAP , CHIP (1608, 50V/0.1uF)		CCUS1H104KC	
C693	nsp	CAP , CHIP (1608, 50V/1000pF)		CCUS1H102KC	
C694	nsp	CAP , CHIP (1608, 50V/0.1uF)		CCUS1H104KC	
C695	nsp	CAP , CHIP (1608, 50V/0.01uF)		CCUS1H103KC	
C696	nsp	CAP , CHIP (1608, 50V/1000pF)		CCUS1H102KC	
C697	nsp	CAP , CHIP (1608, 50V/0.1uF)		CCUS1H104KC	
C698	nsp	CAP , CHIP (1608, 50V/0.01uF)		CCUS1H103KC	
C699	nsp	CAP , CHIP (1608, 50V/1000pF)		CCUS1H102KC	
C701-703	nsp	CAP , CHIP (1608, 50V/0.1uF)		CCUS1H104KC	
C704	nsp	CAP , ELECT		CCEA1CH101T	
C705,706	nsp	CAP , CHIP (1608, 50V/0.1uF)		CCUS1H104KC	
C707	nsp	CAP , ELECT		CCEA1HH100T	
C708	nsp	CAP , CHIP (1608, 50V/0.1uF)		CCUS1H104KC	
C709	00MDK56333300	CAP , CHIP(2012, 33nF/50V)		CCUC1H333KC	
C710,711	943132003120S	CAP , CHIP (3216, 100V/0.1uF)		CCUP2A104KC	
C712,713	00MDK56333300	CAP , CHIP(2012, 33nF/50V)		CCUC1H333KC	
C714,715	943132003120S	CAP , CHIP (3216, 100V/0.1uF)		CCUP2A104KC	
C716	00MDK56333300	CAP , CHIP(2012, 33nF/50V)		CCUC1H333KC	
C717	nsp	CAP , CHIP (1608, 50V/0.1uF)		CCUS1H104KC	
C718	943134003040S	CAP , ELECT		CCET1HKLH332KK8	

Ref. No.	Part No.	Part Name	Remarks	Q'ty	New
C719	00D2544692901	CE04W1J100MT(RFO)		CCEA1HH100T	
C724-726	nsp	RES , CHIP(0 OHM , 5% , 1608)		CRJ10DJ0R0T	
C731,732	00MDD95331300	CAP , CHIP		CCUC1H331JA	
C733	nsp	CAP , METALIZED FILM(100V/0.47UF, 5%)		CCME2A474JR08T	*
C734,735	943132003110S	CAP , CHIP (2012, 100V/0.1uF)		CCUC2A104KC	
C736,737	943132003100S	CAP , CHIP (2012, 100V/0.01uF)		CCUC2A103KC	
C738,739	00MDD95331300	CAP , CHIP		CCUC1H331JA	
C740	nsp	CAP , METALIZED FILM(100V/0.47UF, 5%)		CCME2A474JR08T	*
C741,742	943132003110S	CAP , CHIP (2012, 100V/0.1uF)		CCUC2A104KC	
C743,744	943132003100S	CAP , CHIP (2012, 100V/0.01uF)		CCUC2A103KC	
C745-748	nsp	CAP , CHIP (1608, 50V/0.1uF)		CCUS1H104KC	
C751-753	nsp	CAP , CHIP (1608, 50V/0.1uF)		CCUS1H104KC	
C754	nsp	CAP , ELECT		CCEA1CH101T	
C755,756	nsp	CAP , CHIP (1608, 50V/0.1uF)		CCUS1H104KC	
C757	nsp	CAP , ELECT		CCEA1HH100T	
C758	nsp	CAP , CHIP (1608, 50V/0.1uF)		CCUS1H104KC	
C759	00MDK56333300	CAP , CHIP(2012, 33nF/50V)		CCUC1H333KC	
C760,761	943132003120S	CAP , CHIP (3216, 100V/0.1uF)		CCUP2A104KC	
C762,763	00MDK56333300	CAP , CHIP(2012, 33nF/50V)		CCUC1H333KC	
C764,765	943132003120S	CAP , CHIP (3216, 100V/0.1uF)		CCUP2A104KC	
C766	00MDK56333300	CAP , CHIP(2012, 33nF/50V)		CCUC1H333KC	
C767	nsp	CAP , CHIP (1608, 50V/0.1uF)		CCUS1H104KC	
C768	943134003040S	CAP , ELECT		CCET1HKLH332KK8	
C769	00D2544692901	CE04W1J100MT(RFO)		CCEA1HH100T	
C781,782	00MDD95331300	CAP , CHIP		CCUC1H331JA	
C783	nsp	CAP , METALIZED FILM(100V/0.47UF, 5%)		CCME2A474JR08T	*
C784,785	943132003110S	CAP , CHIP (2012, 100V/0.1uF)		CCUC2A104KC	
C786,787	943132003100S	CAP , CHIP (2012, 100V/0.01uF)		CCUC2A103KC	
C788,789	00MDD95331300	CAP , CHIP		CCUC1H331JA	
C790	nsp	CAP , METALIZED FILM(100V/0.47UF, 5%)		CCME2A474JR08T	*
C791,792	943132003110S	CAP , CHIP (2012, 100V/0.1uF)		CCUC2A104KC	
C793,794	943132003100S	CAP , CHIP (2012, 100V/0.01uF)		CCUC2A103KC	
C795-798	nsp	CAP , CHIP (1608, 50V/0.1uF)		CCUS1H104KC	
C891-893	nsp	RES , CHIP(0 OHM , 5% , 1608)		CRJ10DJ0R0T	
C900,901	nsp	CAP , ELECT		CCEA1HH100T	
C902,903	nsp	CAP , CHIP (1608, 50V/0.1uF)		CCUS1H104KC	
C991	nsp	CAP , ELECT		CCEA1CH100T	
C992	nsp	CAP , CHIP (1608, 50V/0.1uF)		CCUS1H104KC	
C993	nsp	CAP , CHIP (1608, 50V/0.01uF)		CCUS1H103KC	
C994	nsp	CAP , ELECT		CCEA1CH100T	
C995,996	nsp	CAP , CHIP (1608, 50V/0.1uF)		CCUS1H104KC	
RESISTOR GROUP					
R111,112	nsp	RES , METAL OXIDE FILM		CRG1SANJ222RT	
R115	nsp	RES , METAL OXIDE FILM		CRG1SANJ222RT	
R429	nsp	RES , CHIP 1%		CRJ10DF1202T	
R709,710	943124003380S	RES , CHIP , 18 OHM, 1% , 1/8W , 2012		CRJ18AF18R0T	
R711,712	943124003360S	RES , CHIP , 3.3 OHM, 1% , 1/8W , 2012		CRJ18AF3R30T	
R713,714	943124003380S	RES , CHIP , 18 OHM, 1% , 1/8W , 2012		CRJ18AF18R0T	
R715,716	943124003360S	RES , CHIP , 3.3 OHM, 1% , 1/8W , 2012		CRJ18AF3R30T	
R718,719	nsp	RES , METAL OXIDE FILM		CRG1SANJ222RT	
R722	nsp	RES , METAL OXIDE FILM		CRG1SANJ222RT	
R759,760	943124003380S	RES , CHIP , 18 OHM, 1% , 1/8W , 2012		CRJ18AF18R0T	
R761,762	943124003360S	RES , CHIP , 3.3 OHM, 1% , 1/8W , 2012		CRJ18AF3R30T	
R763,764	943124003380S	RES , CHIP , 18 OHM, 1% , 1/8W , 2012		CRJ18AF18R0T	
R765,766	943124003360S	RES , CHIP , 3.3 OHM, 1% , 1/8W , 2012		CRJ18AF3R30T	
R997	nsp	CAP , CHIP (1608, 50V/1000pF)		CCUS1H102KC	
R998	nsp	CAP , CHIP (1608, 50V/0.01uF)		CCUS1H103KC	
R999	nsp	CAP , CHIP (1608, 50V/0.1uF)		CCUS1H104KC	
OTHER PATRS GROUP					
BK51	nsp	BRACKET , PCB		CMD1A569	
BN62	nsp	WIRE ASS'Y (8P, 2MM, 250MM)		CWB1C008250NG	
CN24	nsp	WAFER		CJP11GA117ZY	

Ref. No.	Part No.	Part Name	Remarks	Q'ty	New
CN25	nsp	WAFER , STRAIGHT(DVD LOADER)		CJP06GA19ZY	
CN26	nsp	WAFER , STRAIGHT		CJP05GA19ZY	
CN31	nsp	WAFER(11P, ST 1.25MM)		CJP11GA115ZY	
CN32	nsp	WAFER		CJP11GA117ZY	
CN41	nsp	WAFER, STRSIGHT, 1MM, SMD		CJP30GA193ZY	
CN42	nsp	WAFER , CARD CABLE (SMD, 1MM)		CJP23GA193ZY	
CN43,44	nsp	LOCKING TYPE , STRAIGHT WAFER , 2MM		CJP07GI236ZW	
CN45	nsp	LOCKING TYPE , STRAIGHT WAFER , 2MM		CJP13GI236ZW	
CN61	nsp	LOCKING TYPE , STRAIGHT WAFER , 2.5MM		CJP05GI237ZW	
ET51	nsp	PALTE , EARTH		HJT1A025	
ET61	nsp	PALTE , EARTH		HJT1A025	
ET71	nsp	PALTE , EARTH		HJT1A025	
ET81	nsp	PALTE , EARTH		HJT1A025	
JK51	943643002710S	JACK , BOARD		CJJ4M046Z	
JK62	943643008490S	JACK , DIN 9P		CJS6V001Z	
JK63	90M-YT004010R	TERMINAL , IN/OUT		CJJ4R019W	
JK64	262010004005S	MODULE , OPTICAL (RX,3.3V)		HJSTORX147L	
JK71	943643003280S	TERMINAL , 8P SPEAKER(SCREW, RD/BK/BK/RD)		CJJ5Q020Z	
L101,102	nsp	BEAD , FERRITE (FCM2012KF-121T08 , 120 OHM)		CLZ9R010Z	
L104-107	nsp	BEAD , FERRITE (FCM2012KF-121T08 , 120 OHM)		CLZ9R010Z	
L201	nsp	INDUCTOR CHIP 10UH (3225 PKG)		HLQ10E100KRZ	
L301	nsp	FERRITE , CHIP BEAD(220ohm, 2012)		CLZ9R006Z	
L303,304	nsp	BEAD , FERRITE (FCM2012KF-121T08 , 120 OHM)		CLZ9R010Z	
L401,402	nsp	BEAD , FERRITE (FCM2012KF-121T08 , 120 OHM)		CLZ9R010Z	
L406	nsp	BEAD , FERRITE (FCM2012KF-121T08 , 120 OHM)		CLZ9R010Z	
L501	nsp	BEAD , FERRITE (FCM2012KF-121T08 , 120 OHM)		CLZ9R010Z	
L601	nsp	BEAD , FERRITE (FCM2012KF-121T08 , 120 OHM)		CLZ9R010Z	
L603-605	nsp	BEAD , FERRITE (FCM2012KF-121T08 , 120 OHM)		CLZ9R010Z	
L701-704	nsp	COIL , CHOKE(10UH)		CLZ9Z089Z	
L705-712	nsp	BEAD , FERRITE (FCM2012KF-121T08 , 120 OHM)		CLZ9R010Z	
L720,721	nsp	CHIP , BEAD		HLZ9Z014Z	
L723-728	nsp	CHIP , BEAD		HLZ9Z014Z	
L751-754	nsp	COIL , CHOKE(10UH)		CLZ9Z089Z	
WN24	nsp	WAFER , CD MECHA		CJP16GA117ZY	
X201	943141001190S	CRYSTAL, 16.934MHz, HC-49/SMD, 12pF, 25PPM		COX16934E120S	
X202	943142011280S	16M Resonator		COXCSTCE16M0V51	*
X401	90M-JX001070R	CRYSTAL, 12.288MHz, HC-49/S, 32pF, 50PPM		HOX12288E320C	
X501	943141003490S	CRYSTAL, 13.500MHz, HC-49/SMD, 16pF, 30PPM		COX13500E160S	
	nsp	HEAT SINK		CMY1A304	
	nsp	MICA		KMKCM08A	

ETHER NET PCB ASS'Y

Ref. No.	Part No.	Part Name	Remarks	Q'ty	New
SEMICONDUCTORS GROUP					
D0101	nsp	DIODE , ZENER (CHIP,7.5V)		HVDUDZS7.5BSR	
D0102	nsp	DIODE , SCHOTTKY (40V,3A, DO-214AC) DELTA		CVDSS34SR	
D0103-0105	nsp	DIODE , CHIP		CVDKDS160RTKP	
Q0101	nsp	MOSFET (P-CH, 2.5V POWER TRENCH)		CVTFDC608PZ	
Q0102	nsp	T.R , CHIP , SOT-23		HVTKRC102S	
Q0103	nsp	T.R , CHIP , SOT-23		HVTKRC104S	
Q0104	nsp	T.R , CHIP , SOT-23		CVTKRC104S	
Q0105	nsp	T.R , CHIP , SOT-23		HVTKRC102S	
Q3900	nsp	T.R , CHIP , SOT-23		HVTKRA102S	
Q3901	nsp	T.R , CHIP , SOT-23		HVTKRC102S	
Q4203	nsp	T.R , CHIP , SOT-23		HVTKRC102S	
CAPACITORS GROUP					
C0101	nsp	CAP , CHIP (1608, 50V/1000pF)		CCUS1H102KC	
C0102	nsp	CAP , CHIP (1608, 50V/0.01uF)		CCUS1H103KC	
C0103	nsp	CAP , CHIP (1608, 50V/0.1uF)		CCUS1H104KC	
C0104	nsp	CAP , CHIP (1005, 25V/0.01uF)		CCUI1E103KC	
C0105	nsp	CAP , CHIP (1005, 10V/0.1uF)		CCUI1A104KC	
C0106	nsp	CAP , CHIP ELECT(220UF/6.3V)		HCEC0JRV2221T	
C0107	nsp	CAP , CHIP (1608, 50V/0.1uF)		CCUS1H104KC	
C0108	nsp	CAP , CHIP (1608, 10V/1uF)		CCUS1A105KC	
C0112	nsp	CAP , CHIP (1608, 50V/1000pF)		CCUS1H102KC	
C0113	nsp	CAP , CHIP (1608, 50V/0.01uF)		CCUS1H103KC	
C0114	nsp	CAP , CHIP (1608, 50V/1000pF)		CCUS1H102KC	
C0115	nsp	CAP , CHIP (1005, 16V/0.1uF)		CCUI1C104KC	
C0116	nsp	CAP , CHIP (1608, 50V/0.01uF)		CCUS1H103KC	
C0117	nsp	CAP , CHIP (1005, 50V/0.01uF)		CCUI1H103KC	
C0118	nsp	CAP , CHIP (1005, 50V/1000pF)		CCUI1H102KC	
C0119,0120	nsp	CAP , CHIP (1005, 10V/0.1uF)		CCUI1A104KC	
C0121	nsp	CAP , CHIP (1608, 50V/1000pF)		CCUS1H102KC	
C0122	nsp	CAP , CHIP (1608, 50V/0.1uF)		CCUS1H104KC	
C0123	nsp	CAP , CHIP ELECT		HCEC0JRV2101T	
C0124	nsp	CAP , CHIP (1608, 50V/180pF)		CCUS1H181JA	
C0125	nsp	CAP , CHIP (1005, 16V/0.1uF)		CCUI1C104KC	
C0126	nsp	CAP , CHIP (1608, 50V/0.1uF)		CCUS1H104KC	
C0127	nsp	CAP , CHIP (1608, 50V/1000pF)		CCUS1H102KC	
C0128	nsp	CAP , CHIP (1608, 50V/0.01uF)		CCUS1H103KC	
C0129	nsp	CAP, ELECT, SMD, 220UF/35V, RV2		CCEC1VRV2221T	
C0130	nsp	CAP , CHIP ELECT		HCEC0JRV2101T	
C0131,0132	nsp	CAP , CHIP (1608, 50V/0.1uF)		CCUS1H104KC	
C0133	nsp	CAP , CHIP ELECT		HCEC0JRV2101T	
C0134	nsp	CAP , CHIP ELECT		HCEC1CRV2220T	
C0135	nsp	CAP , CHIP (1608, 50V/1000pF)		CCUS1H102KC	
C0136	nsp	CAP , CHIP (10UF/6.3V K X5R 2012)		CCUC0J106KC	
C0137	nsp	CAP , CHIP (1608, 50V/100pF)		CCUS1H101JA	
C0139	nsp	CAP , CHIP ELECT		HCEC0JRV2101T	
C0141	nsp	CAP , CHIP ELECT		HCEC0JRV2101T	
C0142,0143	nsp	CAP , CHIP (1608, 50V/0.1uF)		CCUS1H104KC	
C0144,0145	nsp	CAP , CHIP (1608, 50V/1000pF)		CCUS1H102KC	
C0146,0147	nsp	CAP , CHIP (3225, 16V/47uF)		CCUR1C476KC	
C0148,0149	nsp	CAP, CHIP (4.7uF/6.3V, 1608, MURATA GRM18)		CCUS0J475KC	
C0150	nsp	CAP, ELECT, SMD, 100UF/35V, RV2		CCEC1VRV2101T	
C3900	nsp	CAP , CHIP (1005, 50V/1000pF)		CCUI1H102KC	
C3901,3902	nsp	CAP , CHIP (1005, 50V/12pF)		CCUI1H120JA	
C3904-3907	nsp	CAP, CHIP (4.7uF/6.3V, 1608, MURATA GRM18)		CCUS0J475KC	
C3908-3918	nsp	CAP , CHIP (1005, 10V/0.1uF)		CCUI1A104KC	
C3923	nsp	CAP, CHIP (4.7uF/6.3V, 1608, MURATA GRM18)		CCUS0J475KC	
C3926-3929	nsp	CAP, CHIP (4.7uF/6.3V, 1608, MURATA GRM18)		CCUS0J475KC	
C3930-3939	nsp	CAP , CHIP (1005, 10V/0.1uF)		CCUI1A104KC	
C3944	nsp	CAP, CHIP (4.7uF/6.3V, 1608, MURATA GRM18)		CCUS0J475KC	
C3947	nsp	CAP, CHIP (4.7uF/6.3V, 1608, MURATA GRM18)		CCUS0J475KC	
C3950-3958	nsp	CAP , CHIP (1005, 10V/0.1uF)		CCUI1A104KC	

Ref. No.	Part No.	Part Name	Remarks	Q'ty	New
C4200	nsp	CAP , CHIP (1005, 50V/1000pF)		CCUI1H102KC	
C4202	nsp	CAP , CHIP (1608, 50V/0.022uF)		CCUS1H223KC	
C4203	nsp	CAP , CHIP (1005, 50V/1000pF)		CCUI1H102KC	
C4204	nsp	CAP, CHIP (4.7uF/6.3V, 1608, MURATA GRM18)		CCUS0J475KC	
C4205	nsp	CAP , CHIP (1005, 50V/1000pF)		CCUI1H102KC	
C4206	nsp	CAP, CHIP (4.7uF/6.3V, 1608, MURATA GRM18)		CCUS0J475KC	
C4209	nsp	CAP , CHIP (1005, 50V/1000pF)		CCUI1H102KC	
C4210,4211	nsp	CAP , CHIP (1005, 10V/0.1uF)		CCUI1A104KC	
C4213	nsp	CAP, CHIP (4.7uF/6.3V, 1608, MURATA GRM18)		CCUS0J475KC	
C4215,4216	nsp	CAP, CHIP (4.7uF/6.3V, 1608, MURATA GRM18)		CCUS0J475KC	
C4218	nsp	CAP, CHIP (4.7uF/6.3V, 1608, MURATA GRM18)		CCUS0J475KC	
C4219-4221	nsp	CAP , CHIP (1005, 10V/0.1uF)		CCUI1A104KC	
C4225	nsp	CAP , CHIP (1608, 50V/1000pF)		CCUS1H102KC	
C4226	nsp	CAP, CHIP (4.7uF/6.3V, 1608, MURATA GRM18)		CCUS0J475KC	
C4228	nsp	CAP , CHIP (1005, 10V/0.1uF)		CCUI1A104KC	
C4229	nsp	CAP , CHIP (1608, 50V/0.01uF)		CCUS1H103KC	
C4230	nsp	CAP , CHIP (1608, 50V/0.1uF)		CCUS1H104KC	
C4231-4233	nsp	RES , CHIP(0 OHM , 5% , 1608)		CRJ10DJ0R0T	
C4234	nsp	CAP , CHIP (1608, 50V/1000pF)		CCUS1H102KC	
C4235	nsp	CAP , CHIP (1608, 50V/0.01uF)		CCUS1H103KC	
C4236	nsp	CAP , CHIP (1608, 50V/0.1uF)		CCUS1H104KC	
C4237	nsp	CAP , CHIP (1608, 50V/1000pF)		CCUS1H102KC	
C4238	nsp	CAP , CHIP (1608, 50V/0.01uF)		CCUS1H103KC	
C4239	nsp	CAP , CHIP (1608, 50V/0.1uF)		CCUS1H104KC	
C4242	nsp	CAP , CHIP (1608, 50V/1000pF)		CCUS1H102KC	
C4243	nsp	CAP , CHIP (1608, 50V/0.01uF)		CCUS1H103KC	
C4244-4246	nsp	CAP , CHIP (1608, 50V/0.1uF)		CCUS1H104KC	
RESISTORS GROUP					
R0113	nsp	RES, CHIP 3.9KOHM/1608/1%		CRJ10DF3901T	
R0114	nsp	RES , CHIP(1608, 1% , 43K OHM)		CRJ10DF4302T	
R0115	nsp	RES, CHIP (5.1K 1%)		CRJ10DF5101T	
R3916	nsp	RES , CHIP(1608, 1% , 3K OHM)		CRJ10DF3001T	
R3917	nsp	RES , CHIP 1%		CRJ10DF1302T	
R3918	nsp	RES, CHIP 6.2KOHM/1608/1%		CRJ10DF6201T	
R4200	nsp	RES, CHIP 1% 75 OHM		CRJ10DF75R0T	
R4202,4203	nsp	RES, CHIP 1% 75 OHM		CRJ10DF75R0T	
R4206-4209	nsp	RES , CHIP(1608, 1% , 51 OHM)		CRJ10DF51R0T	
R4223	nsp	RES, CHIP 6.8KOHM/1608/1%		CRJ10DF6801T	
R4224	nsp	RES, CHIP 5.6KOHM/1608/1%		CRJ10DF5601T	
OTHER PATRS GROUP					
L0101	nsp	COIL , SMD POWER (22UH/3A)		CLQ13E220MRZ	
L3900-3902	nsp	FERRITE , CHIP BEAD(220ohm, 2012)		CLZ9R006Z	
L4202-4206	nsp	FERRITE , CHIP BEAD(220ohm, 2012)		CLZ9R006Z	
N0101	nsp	WAFER , SMD (2MM PITCH)		CJP05GA208ZY	
N0103	nsp	WAFER, 2mm, SMD, Vertical, 8P		CJP08GA208ZY	
N4200	nsp	RJ45 with LED		CJJ9L019Z	
N4201	nsp	WAFER , CARD CABLE (SMD, 1MM)		CJP23GA193ZY	
U0101	nsp	POLY SWITCH (1.6A, 8V)		CBA5H1600PSUYT	
U0103	nsp	IC , DCDC Converter (3.5A, SOP8) SANKEN		CVISI8005QTL	
U0104	nsp	REGULATOR (SHARP)		HVIPQ012FZ01ZP	
U105	943239007760S	I.C , REGULATOR (3.3V, DPAK-5)		CVIKIA78R033F	
U3900	nsp	Network Media processor		CVIDM860	
U3901	nsp	1G NAND Flash		CVINAND01GW3B2CN6E	
U3902	nsp	IC, SDRAM (4M x 16Bit x 4Banks, 166Mhz, DRAM)		CVIM12L2561616A6TG2K	
U4201	nsp	Pulse-Trans (HIGH SPEED LAN MAGNETICS)		CVIS558-5999U7F	
U4202	nsp	I.C, ETHERNET PHY		CVILAN8700CAEZGTR	
U4204	nsp	I.C , IPOD AUTHENTICATION CHIP FROM MARANTZ		CVI236710076509S-DM	
X3900	nsp	X-tal (SMD, 24Mhz, FCX-05)		COX240001060SD	
Z4201,4202	nsp	BRACKET , PCB		CMD1A569	

SMPS PCB ASS'Y

Ref. No.	Part No.	Part Name	Remarks	Q'ty	New
SEMICONDUCTORS GROUP					
IC90	90M-HC300960R	I.C , REGULATOR(TO220IS-4)		CVIKIA78D33PI	
IC91	943235003220S	IC, CoolSET ICE3B0365J		CVIICE3B0365J	
IC92	943235003200S	IC , COOLSET		CVIICE2B265	
IC93	943235003210S	I.C , PWM CONTROLLER(PG-DIP-8)		CVIICE2QS01	
IC94	00MHC3891899F	I.C , VOL REGULATOR(18V, TO-220IS)		CVIKIA7818API	
IC95,96	90M-HC300770R	I.C , REGULATOR		HVIKIA431BAT	
IC97	00MHC3891299F	I.C , REGULATOR		HVIKIA7812API	
IC98	00D2631099022	I.C , REGULATOR		HVIKIA7912PI	
IC99	90M-HC300770R	I.C , REGULATOR		HVIKIA431BAT	
D901,902	90M-HD201860R	DIODE , SCHOTTKY		HVDUF4004T	
D903	90M-HD201870R	DIODE , SCHOTTKY		HVDUF4007T	
D904	90M-HD201860R	DIODE , SCHOTTKY		HVDUF4004T	
D905	90M-HD201870R	DIODE , SCHOTTKY		HVDUF4007T	
D906,907	90M-HD201860R	DIODE , SCHOTTKY		HVDUF4004T	
D908	90M-HD201870R	DIODE , SCHOTTKY		HVDUF4007T	
D909,910	943203003150S	DIODE		HVD1N4007T	
D911	nsp	DIODE , FAST SWITCHING(0.5W, SOD-123)		CVD1N4448W	
D912	nsp	DIODE , ZENER		HVDMTZJ20BT	
D913	nsp	DIODE , ZENER		HVDMTZJ16BT	
D914,915	nsp	DIODE , ZENER		HVDMTZJ20BT	
D916	nsp	DIODE , ZENER		HVDMTZJ24BT	
D917	nsp	DIODE , FAST SWITCHING(0.5W, SOD-123)		CVD1N4448W	
D918	90M-HD201890R	DIODE , ULTRA FAST (DELTA)		HVDUF5404H	
D919	nsp	DIODE , ZENER(27V/0.5W, SOD-123)		CVDMM1Z27	
D921	nsp	DIODE , ZENER(20V/0.5W, SOD-123)		CVDMM1Z20	
D922	943203003150S	DIODE		HVD1N4007T	
D923,924	nsp	DIODE , FAST SWITCHING(0.5W, SOD-123)		CVD1N4448W	
D927-929	nsp	DIODE , FAST SWITCHING(0.5W, SOD-123)		CVD1N4448W	
D931	90M-HD201990R	DIODE		HVD31DQ06H	
D933	90M-HD201860R	DIODE , SCHOTTKY		HVDUF4004T	
D934	nsp	DIODE , ZENER(27V/0.5W, SOD-123)		CVDMM1Z27	
D935	nsp	DIODE , ZENER		HVDMTZJ16BT	
D942	943204003160S	DIODE , SCHOTTKY (100V/3A)		HVD31DQ10FC5	
D943	90M-HD201890R	DIODE , ULTRA FAST (DELTA)		HVDUF5404H	
D944,945	90M-HD201860R	DIODE , SCHOTTKY		HVDUF4004T	
D951	943203003140S	DIODE , SCHOTTKY(20A, 200V)		CVDFCH20A20	
Q901,902	90M-HT600060R	T.R		HVTKSA708YT	
Q903	943235003230S	I.C		CVISPP11N60C3	
Q925	90M-HT800050R	T.R		HVTKTC3198YT	
Q932	90M-BA001460R	T.R , TO-92M		HVTKRC107MT	
Q934	00D2710323907	T.R		HVTKTA1273YT	
Q936	00MBA20001000	T.R , TO-92M		HVTKRC102MT	
Q937	00MBA10001000	T.R , TO-92M		HVTKRA102MT	
CAPACITORS GROUP					
C901	nsp	CAP , ELECT(K3J, 450V/270UF, 105C, 35X40)		CCET450VK3J271AK	*
C902	943134010940S	CAP, ELECT(22uF/100V, 6X11)		CCEA2AH220TS	
C903	00MDK96472300	CAP , CHIP		CCUC1H472KC	
C904	943132003090S	CAP , CHIP		CCUC1H474KC	
C905	nsp	CAP , CERAMIC		CCKT3A222KBL	
C906	90M-OA000320R	CAP , ELECT		CCEA1HH220TS	
C907	943134010940S	CAP, ELECT(22uF/100V, 6X11)		CCEA2AH220TS	
C908	00MDK96472300	CAP , CHIP		CCUC1H472KC	
C909	943132003090S	CAP , CHIP		CCUC1H474KC	
C910	nsp	CAP , CERAMIC		CCKT3A222KBL	
C911	943134003060S	CAP , ELECT(KRH, 450V/22UF, 12.5X25)		CCET450VKRH220KS	
C912	00MDK56222300	CAP , CHIP(2012, 2200PF/50V)		CCUC1H222KC	
C913	00MDD95101300	CAP , CHIP		CCUC1H101JA	
C914	nsp	CAP , CERAMIC		CCKT3A471KBL	
C915	943134010940S	CAP, ELECT(22uF/100V, 6X11)		CCEA2AH220TS	
C916	nsp	CAP , CHIP		CCUC1H471JA	

Ref. No.	Part No.	Part Name	Remarks	Q'ty	New
C917	nsp	CAP , CERAMIC		CCKT3A222KBL	
C918	943132002470S	CHIP, CAP 0.1UF/50V/2012		CCUC1H104KC	
C919	nsp	CAP , CHIP		CCUC1H103KC	
C921	943132002470S	CHIP, CAP 0.1UF/50V/2012		CCUC1H104KC	
C922	943134003030S	CAP , ELECT(KRM, 100V/1UF, 105C, 5X11)		CCEA2AH1R0TS	
C923	943132002470S	CHIP, CAP 0.1UF/50V/2012		CCUC1H104KC	
C924	90M-OA000320R	CAP , ELECT		CCEA1HH220TS	
C925-928	943132002470S	CHIP, CAP 0.1UF/50V/2012		CCUC1H104KC	
C929	nsp	CAP , CHIP		CCUC1H103KC	
C930	943132002470S	CHIP, CAP 0.1UF/50V/2012		CCUC1H104KC	
C931	nsp	CAP , ELECT (105°C, 10X25) 10V 2200uF, KLH SERIES		CCEA1AKLH222EKS	*
C932	nsp	CAP , CHIP(2012, 1uF/50V)		CCUC1H105KC	
C933	00MOA47701020	CAP , ELECT		CCEA1AH471TS	
C934	nsp	CAP , CHIP		CCUC1H103KC	
C935	90M-OA000320R	CAP , ELECT		CCEA1HH220TS	
C936	00MOA47701020	CAP , ELECT		CCEA1AH471TS	
C937	nsp	CAP , ELECT		CCEA1EH102ES	
C938	943134003000S	CAP , ELECT		CCEA1EH101TS	
C939	90M-OA000320R	CAP , ELECT		CCEA1HH220TS	
C940	nsp	CAP , CHIP(2012, 1uF/50V)		CCUC1H105KC	
C941	943134007810S	CAP , ELECT(10V/2200UF, 105C, 10X20)		CCEA1AH222ES	
C942	90M-OA000310R	CAP , ELECT		CCEA1HH1R0TS	
C943	00MOA47701020	CAP , ELECT		CCEA1AH471TS	
C944	90M-OA000320R	CAP , ELECT		CCEA1HH220TS	
C945	943132002470S	CHIP, CAP 0.1UF/50V/2012		CCUC1H104KC	
C946	nsp	CAP , ELECT		CCEA1EH102ES	
C947,948	943134003000S	CAP , ELECT		CCEA1EH101TS	
C949	90M-OA000320R	CAP , ELECT		CCEA1HH220TS	
C950	943134003000S	CAP , ELECT		CCEA1EH101TS	
C951	nsp	CAP , ELECT		CCEA1EH220TS	
C952	nsp	CAP , CERAMIC		CCKT3A102KBL	
C953	nsp	CAP , CHIP		CCUC1H103KC	
C954	nsp	CHIP, CAP 0.1UF/50V/2012		CCUC1H104KC	
C955	nsp	CAP , CHIP		CCUC1H103KC	
C956	nsp	CHIP, CAP 0.1UF/50V/2012		CCUC1H104KC	
C957	nsp	CAP , CHIP		CCUC1H103KC	
C958	nsp	CHIP, CAP 0.1UF/50V/2012		CCUC1H104KC	
C959	nsp	CAP , CHIP		CCUC1H103KC	
C960	nsp	CHIP, CAP 0.1UF/50V/2012		CCUC1H104KC	
C961	nsp	CAP , CHIP		CCUC1H103KC	
C962	nsp	CHIP, CAP 0.1UF/50V/2012		CCUC1H104KC	
C963	nsp	CAP , CHIP		CCUC1H103KC	
C965	nsp	CAP , CERAMIC		CCKT3A102KBL	
C967,968	nsp	CAP , ELECT		CCEA1HH102ES	
C972-975	nsp	CHIP, CAP 0.1UF/50V/2012		CCUC1H104KC	
C991	nsp	CAP , CHIP		CCUC1H224KC	
RESISTORS GROUP					
R910	nsp	RES , WIRE WOUND (1W/0.68 OHM)		CRW1PJ0R68V	
R911	nsp	RES , METAL OXIDE FILM		CRG2ANJ683R	
R920,921	nsp	RES , WIRE WOUND (1 W/ 0.2 OHM)		CRW1PJR20V	
R928	nsp	RES , METAL OXIDE FILM (2W, 68K)		CRG2SANJ683RT	
R934	nsp	RES, CHIP, 6.8K OHM, 1%, 1/8W, 2012		CRJ18AF6801T	
R937	nsp	RES , METAL OXIDE FILM (1W, 10K OHM)		CRG1ANJ103R	
R958	nsp	RES , METAL OXIDE FILM(1W, 20ohm V)		CRG1ANJ220R	
R960	nsp	RES , METAL OXIDE(270/1W)		CRG1ANJ271H	
R968	nsp	RES , METAL OXIDE FILM		CRG1ANJ100H	
R985	nsp	RES, CHIP, 43K OHM, 1%, 1/4W, 3216		CRJ14CF4302T	
OTHER PATRS GROUP					
BD89-99	90M-FC900340R	CHIP , BEAD		HLZ9Z014Z	
BN25	nsp	WIRE ASS'Y		CWB5A906120EG	
BN26	nsp	WIRE ASS'Y		CWB1B005120EG	

Ref. No.	Part No.	Part Name	Remarks	Q'ty	New
△ CN91	943641009280S	INLET , AC (250V/2.5A PCB MOUNT TYPE)		CJJ8A012Z	
CN92	nsp	WIRE ASS'Y (5P, 2.5MM, 350MM, WITH HEMELON)		CWB1D90535058001	
CN93	nsp	WIRE ASS'Y (13P, 2MM, 120MM)		CWB1C91312047	
CN94	nsp	WIRE ASS'Y (7P, 2MM, 150MM)		CWB1C90715047	
△ CX91	943133003080S	CAP , POLYPROPYLENE FILM		CCQF2E224KZE	
△ CX92	90M-OF100550R	CAP , X2		CCQF2E104KZC	
△ CY91-93	90M-DK100930R	CAP , CERAMIC (400V Y-CAP)		CCKDHS102ME	
△ CY94	90M-DK100870R	CAP , CERAMIC (400V Y-CAP)		CCKDHS222ME	
△ DB91	943203003170S	DIODE , BRIDGE		HVDGBJ606	
△ F901	00D2061090060	FUSE, 215 SERIES, 4A, 250V		CBA2C4000TLHEY	
FH91,92	nsp	HOLDER , FUSE		KJCF5S	
HS91	nsp	PROTECTOR , THERMAL (80'C, 100mm) ST-22 SEIRES		CRTST22080100W	
JS91-99	00MNI05000110	RES , CHIP , 0 OHM, 5% , 1/8W , 2012		CRJ18AJOR0T	
L921-923	943111003320S	COIL , CHOCK(6.8uH)		CLZ9Z040Y	
L925	943111003320S	COIL , CHOCK(6.8uH)		CLZ9Z040Y	
L928	943111003330S	COIL , CHOKE(7UH)		CLZ9Z090Z	
L929,930	nsp	CORE , BEAD		HLZ93001Z	
△ LF91,92	943149003340S	LINE FILTER(10MH)		CLZ9Z086Z	
△ PC91-95	90M-HW100710R	I.C , PHOTO COUPLER		HVIPC17L1CB	
△ TF91	943102011250S	TRANS , SWITCHING (EE1625, M-CR603)		CLT9Z064ZE	*
△ TF92	943102011260S	TRANS , SWITCHING (EE2525, M-CR603)		CLT9Z065ZE	*
△ TF93	943102011270S	TRANS , SWITCHING (EER4042, M-CR603)		CLT9Z066ZE	*
△ TH91	90M-HH000110R	NTC , THERMISTOR (10MM PITCH)		KRT5D15MSFC	
△ VT91	943251011310S	VARISTOR(560V, 14mm)		CRVSVC561D14A	*
	nsp	HOLDER, IC		CMH1A251	
	nsp	BRACKET , THERMAL SENSOR		CMD1A720	
	nsp	HEAT SINK		CMY2A283	
	nsp	HEAT, SINK		CMY3A222X	
	nsp	SCREW		CTB3+10JR	
	nsp	SCREW		CTB3+10JR	
	nsp	SCREW		CTB3+8JR	