

Service  
Service  
Service



# Service Manual



## TABLE OF CONTENTS

	Page
Location of pc boards & Version variations .....	1-2
Technical Specifications .....	1-3
Measurement setup .....	1-4
Service Aids, Safety Instruction, etc. ....	1-5
Disassembly Instructions & Service positions .....	2
Service Test Programs .....	3-1
Set Block diagram .....	4-1
Set Wiring diagram .....	5-1
Front Board .....	6
ECO6 Tuner Board : Systems Non-Cenelec .....	7A
Systems Cenelec .....	7B
5DTC Module (MP3 Version) .....	10
Power 2003 Module (100W Class D) .....	11
Set Mechanical Exploded view & parts list .....	12

© Copyright 2003 Philips Consumer Electronics B.V. Eindhoven, The Netherlands  
 All rights reserved. No part of this publication may be reproduced, stored in a retrieval system or transmitted, in any form or by any means, electronic, mechanical, photocopying, or otherwise without the prior permission of Philips.

Published by BB 0313 Service Audio Printed in The Netherlands Subject to modification



3139 785 30290

Version 1.0



# PHILIPS

**SPECIFICATIONS****GENERAL:**

Mains voltage : 110-127V/220-240V Switchable for /21/21M  
 120V for /37  
 220V for /33  
 220-230V for /22  
 230-240V for /30

Mains frequency : 50/60Hz  
 Clock accuracy : < 4 seconds per day  
 Dimension centre unit : 175 x 268 x 316mm

**Power consumption**

Active : 80W for /22/33/37  
 Active : 90W for /21/21M  
 Standby : < 15W (DEMO mode off)  
 ECO Power Standby : < 0.5W for /22/33/37  
 ECO Power Standby : < 1W for /21/21M

**TUNER:****FM**

Tuning range : 87.5-108MHz  
 Grid : 50kHz  
 100kHz for /37  
 IF frequency : 10.7MHz  $\pm$  25kHz  
 Aerial input : 75 ohm coaxial  
 300 ohm click fit for /37  
 Sensitivity at 26dB S/N : < 7 $\mu$ V  
 Selectivity at 600kHz bandwidth : > 25dB  
 Image rejection : > 25dB [> 75dB]  
 Distortion at RF=1mV, dev. 75kHz : < 3%  
 -3dB Limiting point : < 8 $\mu$ V  
 Crosstalk at RF=1mV, dev. 40kHz : > 18dB

**MW**

Tuning range : 531-1602kHz  
 530-1700kHz for /21/21M/37  
 Grid : 9kHz  
 10kHz for /21/21M/37  
 IF frequency : 450kHz  $\pm$  1kHz  
 Aerial input : Frame aerial  
 Sensitivity at 26dB S/N : < 4.4mV/M  
 Selectivity at 18kHz bandwidth : > 18dB  
 IF rejection : > 45dB  
 Image rejection : > 28dB  
 Distortion at RF=50mV, M=80% : < 5%

**AMPLIFIER:**

Output power (6 ohm, 1kHz, 10% THD)  
 L & R : 2 x 100W RMS

Output power (6 ohm, 60Hz-12.5kHz, 10% THD)  
 L & R : 2 x 95W FTC /37

Frequency response within -3dB : 50Hz-16kHz  
 MAX Sound : On / Off  
 Digital Sound Control (DSC) : Jazz / Rock / Pop / Optimal  
 Virtual Environment Control (VEC) : Cyber Hall / Concert /  
 Cinema / Off

**Input sensitivity**

Aux in (at 1kHz) : 500mV at 600 ohm  
 CDR in (at 1kHz) : 1000mV at 600 ohm  
 USB (at 1kHz) : 830mV at 600 ohm

**Output sensitivity**

Headphone output at 32 ohm : 15mW  $\pm$  2dB (Max. vol.)

**5DTC:**

Measurement done directly at the connector on the board.

Output Resistance : < 100 ohm  
 Output Voltage (0dB, 1kHz) : 0.5Vrms  $\pm$  1dB (unloaded)  
 Channel Unbalance : <  $\pm$ 1dB  
 Channel Separation (1kHz) : > 60dB  
 Frequency Response ( $\pm$ 3dB) : 20Hz-20kHz  
 Signal to Noise Ratio : > 76dBA  
 MP3-CD Bit Rate : 32-256 kbps  
 Sampling Frequencies : 32, 44.1, 48 kHz

**USB:**

Measurement done directly at the connector on the board.

Output Resistance : < 1.5 kohm  
 Output Voltage (0dB, 1kHz) : 830mVrms  $\pm$  1.5dB  
 ( $R_L = 33$  kohm)  
 Channel Unbalance : <  $\pm$ 1dB  
 THD + Noise (0dB, 1kHz) : < 0.3%  
 Channel Separation (0dB, 1kHz) : > 40dB  
 Frequency Response ( $\pm$ 3dB) : 20Hz-20kHz  
 Signal to Noise Ratio : > 75dBA

[...] Values indicated are for "ECO6 Cenelec Board" only.

## DISMANTLING INSTRUCTIONS

### Dismantling of the 5DTC Module

- 1) Loosen 4 screws and remove the Cover Top (pos 255) by sliding it out towards the rear before lifting up.
  - 2 screws on the rear
  - 1 screw each on the left & right side
- 2) Loosen 3 screws each to remove the Panel Left (pos 253) and Panel Right (pos 254). The Panels are removed by sliding it towards the rear and outwards.
  - 1 screw on the side
  - 2 screws on the rear
- 3) Take a paper clip or any stiff wire diameter of 1mm-1.5mm. Place the set in position and insert the paper clip or stiff wire as shown in Figure 1.
- 4) To remove the Cover CD Orn (pos 111), you have to feel and give a push in the correct direction (see Figure 1) and correct position (see Figure 2) to release the catch of the Cover CD Orn before removing it out.
- 5) Loosen 4 screws A (see Figure 3 and Figure 9) to remove the 5DTC Module (pos 1103).
  - 2 screws on the front
  - 2 screws on the rear

*Note : For information on the 'Emergency opening of the trays' of the 5DTC Module, refer to Chapter 10 (Page 10-7).*

Figure 1

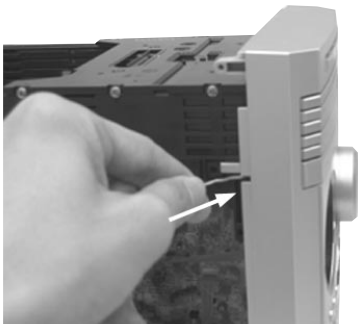

Figure 2

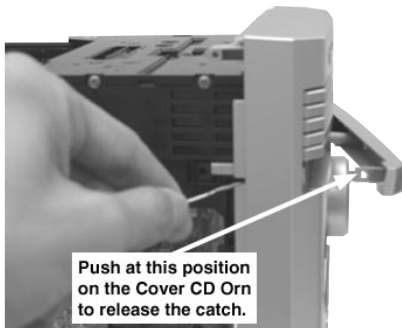
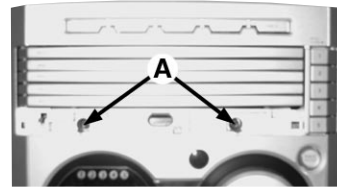

Figure 3



### Detaching the Front Panel assembly from the Bottom/Rear assembly

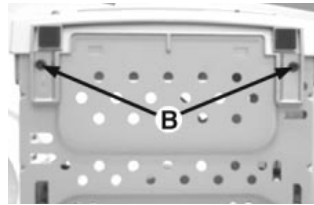

Figure 4

- 1) Remove 2 screws B (pos 282) as shown in Figure 4 from the bottom of the Cabinet Front (pos 101).
- 2) Release the fixation of the Combi Board (pos 1102-1001) to Bracket Combi (pos 252) by releasing the 2 catches C1 (see Figure 5) and pulling the Combi Board outwards as shown in Figure 6.
- 3) Uncatch 2 catches C2 (see Figure 5) on the left & right sides of the Cabinet Front (pos 101) and slides the Front Panel assembly out towards the front.

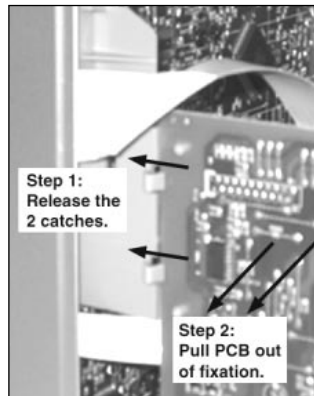

Figure 6

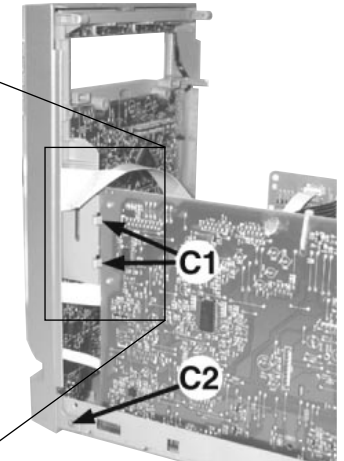

Figure 5

## DISMANTLING INSTRUCTIONS

**Dismantling of the Front Panel assembly**

- 1) The Knob Volume (pos 136) can be removed by pulling it out in the direction as shown in Figure 7.
- 2) Loosen 4 screws D (see Figure 8) to remove the Bracket Top (pos 251) and CDC Key Board (pos 1105B).
- 3) Loosen 2 screws E (see Figure 8) to remove the Bracket Combi (pos 252).
- 4) Loosen 9 screws F (see Figure 8) to remove the Front Board (pos 1105A).
- 5) Loosen 3 screws G (see Figure 8) to remove the USB PC LINK Board (pos 1106).

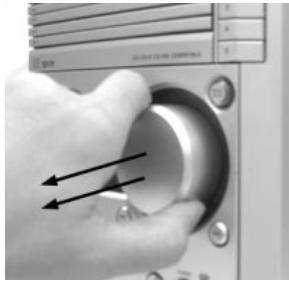
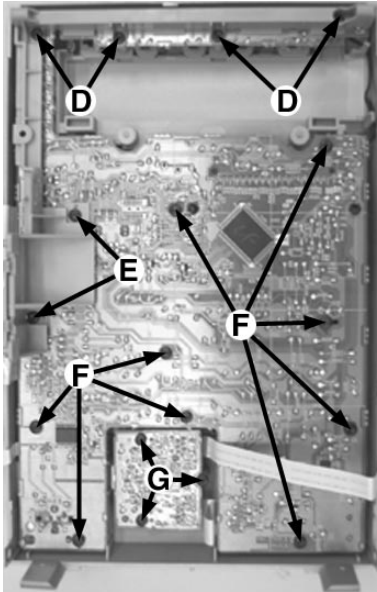

Figure 7

Figure 8

**Dismantling of the Rear Panel assembly**

- 1) Loosen 3 screws H and 2 catches C3 (see Figure 9) to remove the Tuner Board assembly.
- 2) Loosen 1 screw K (see Figure 9) to free the Mains Socket Board (pos 1102-1002B).
- 3) Loosen 4 screws J and 2 catches C4 (see Figure 9) to remove the Cabinet Rear (pos 256) by sliding it out towards the rear (see Figure 10).  
*Note: Tuner Board assembly and Mains Socket Board can also be removed together with the Cabinet Rear.*
- 4) Loosen 4 screws L (see Figure 9) to remove the Fan (pos 1104) from the Cabinet Rear.

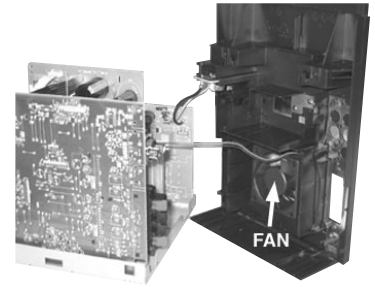
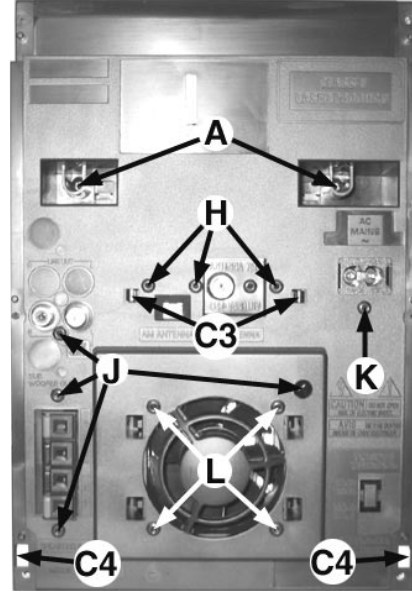

Figure 10

Figure 9



### DISMANTLING INSTRUCTIONS

#### Repair Hints & Service Positions

1) During repair it is possible to disconnect the ECO6 Tuner board and/or 5DTC Module completely unless the fault is suspected to be in that area. This will not affect the performance of the rest of the set.

Note: The flex cables are very fragile, care should be taken not to damage them during repair. After repair, be very sure that the flex cables are inserted properly into the flex sockets before encasing, otherwise faults may occur.

Service position A

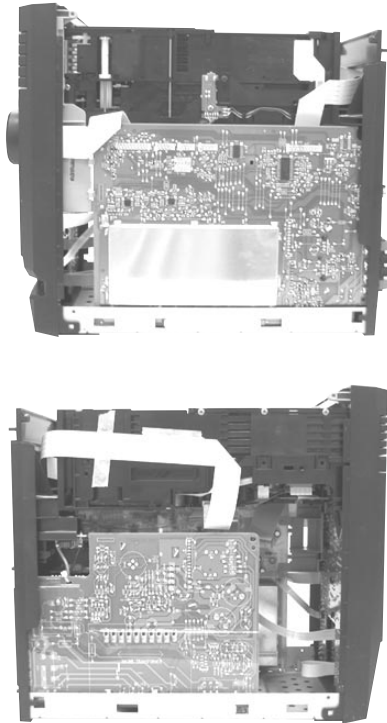

Service position B

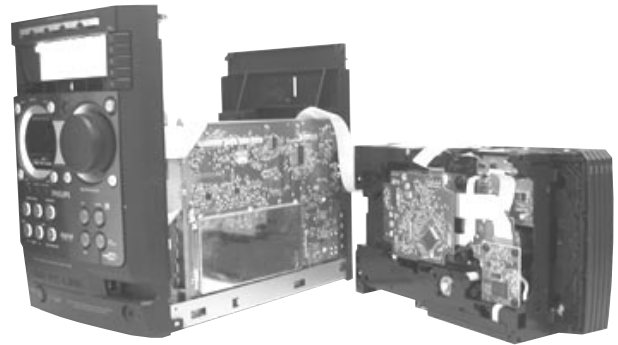

Service position C

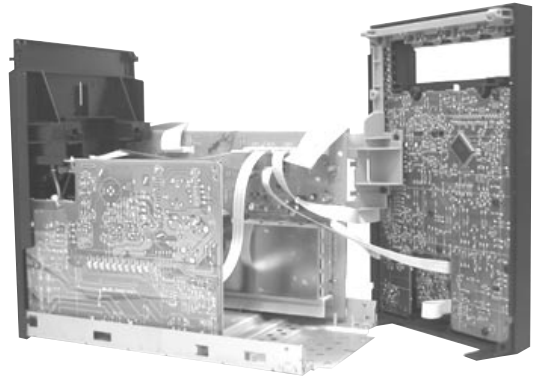

SERVICE TEST PROGRAM

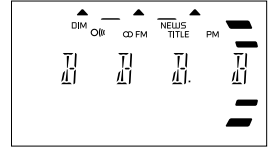
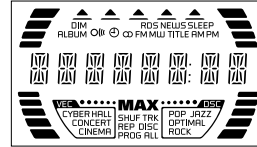
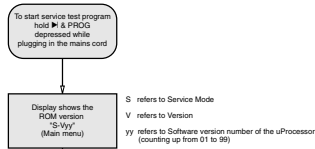
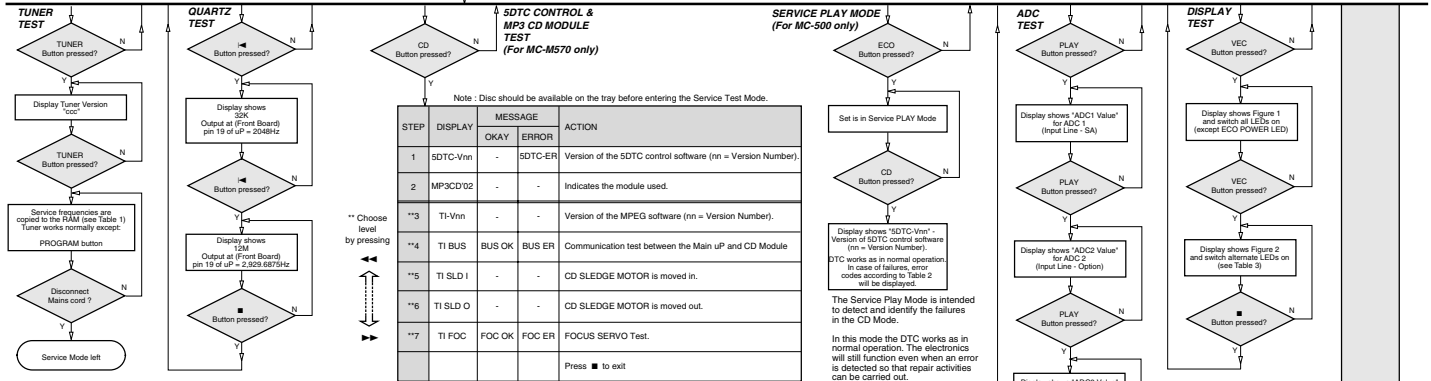

Figure 1

Figure 2



PRESET	Europe "EUR"	East Europe "EAS"	East Eur. Extended-band "EAS"	USA "USA"	Oversea "OSE"
1	87.5MHz	87.5MHz	65.81MHz	87.5MHz	87.5MHz
2	108MHz	108MHz	108MHz	108MHz	108MHz
3	531kHz	531kHz	74MHz	530kHz	531/530kHz*
4	1602kHz	1602kHz	87.5MHz	1700kHz	1602/1700kHz*
5	558kHz	558kHz	531kHz	560kHz	558/560kHz*
6	1494kHz	1494kHz	1602kHz	1500kHz	1494/1500kHz*
7	87.5MHz	87.5MHz	558kHz	98MHz	87.5/98MHz*
8	87.5MHz	87.5MHz	1494kHz	87.5MHz	87.5MHz
9	87.5MHz	87.5MHz	98MHz	87.5MHz	87.5MHz
10	87.5MHz	87.5MHz	70.01MHz	87.5MHz	87.5MHz
11	98MHz	98MHz	65.81MHz	87.5MHz	98/87.5MHz**

Table 1

Note: \* Depending on the selected grid frequency (9 or 10kHz).  
 By holding the PROG and ►► buttons depressed while switching on the Mains supply, one of the undermentioned features will be activated:  
 - the tuning grid frequency is toggled between 9kHz and 10kHz for the Oversea (21) version.  
 - the extended FM1 (65.81MHz - 74MHz) is toggled on and off for East Eur. (34) version.

Error code	Error Description
E1000	Focus Error Triggered when the focus cannot be found within a certain time when starting up the CD, or if the focus is lost for more than a certain time during playing of CD.
E1001	Radial Error Triggered when the radial servo is off-track for a certain time during playing of CD.
E1002	Sledge In Error The sledge did not reach its inner position (inner-switch is still close) before approximately 6 seconds have passed by. Inner-switch or sledge motor problem.
E1003	Sledge Out Error The sledge did not come out of its inner position (inner-switch is still open) before approximately 250ms have passed by. Inner-switch or sledge motor problem.
E1005	Jump Error Triggered in normal play when the jump destination could not be found within a certain time.
E1006	Subcode Error Triggered when a new subcode was missing for a certain time during playing of CD.
E1007	PLL Error The Phase Lock Loop could not lock within a certain time.
E1008	Turntable Motor Error Generated when the CD could not reach 75% of speed during start-up within a certain time. Disc motor problem.
E1020	Focus Search Error The focus point has not been found within a certain time.
E1061	The tray could not enter the inside position and is opening again. This can happen if the tray is blocked such that it cannot go fully inside, or if the SDTC control module is defective and never closes.
E1079	The tray could not reach the outside position and is stopped at its blocked position. This can happen if the tray is blocked such that it cannot go fully outside, or if the SDTC control module is defective and never opens.

Table 2

ADC Test is used for checking the ADC inputs to the microprocessor.

The display shows an ADC value between 0 and 255 for an input signal between 0 and 5V.

LEDs	MC-M570	MC-500
CD	OFF	-
TUNER	ON	-
AUX	OFF	-
USB PC LINK	ON	-
MAX SOUND	OFF	OFF
USB Indicator	ON	ON

Table 3

TEST	Activated with	ACTION
EEPROM TEST	►► ■ to Exit	A test pattern will be sent to the EEPROM. "PASS" is displayed if the uProcessor read back the test pattern correctly, otherwise "FAIL" will be displayed.
EEPROM FORMAT TEST	◄◄	Load default data. Display shows "NEW" for 1 second. <b>Caution! All presets from the customer will be lost!</b>
DEMO TOGGLE	MAX SOUND	Pressing this button will toggle between DEMO ON and DEMO OFF. The DEMO status will scroll once across the Display.
ROTARY ENCODER TEST	Rotary Volume Knob	Display shows value for 2 seconds. Values increases or decreases until Volume Maximum (0dB) or Volume Minimum (VOL MUTE) is reached.
MICRONAS FIRMWARE VERSION	USB PC LINK ■ to Exit	To read out the Firmware Version of IC UAC3553 on the USB PC LINK Board. Display shows "xxxxx" (xxxxx = Firmware version number).
LEAVE SERVICE TEST PROGRAM	Disconnected mains cord	

SET BLOCK DIAGRAM

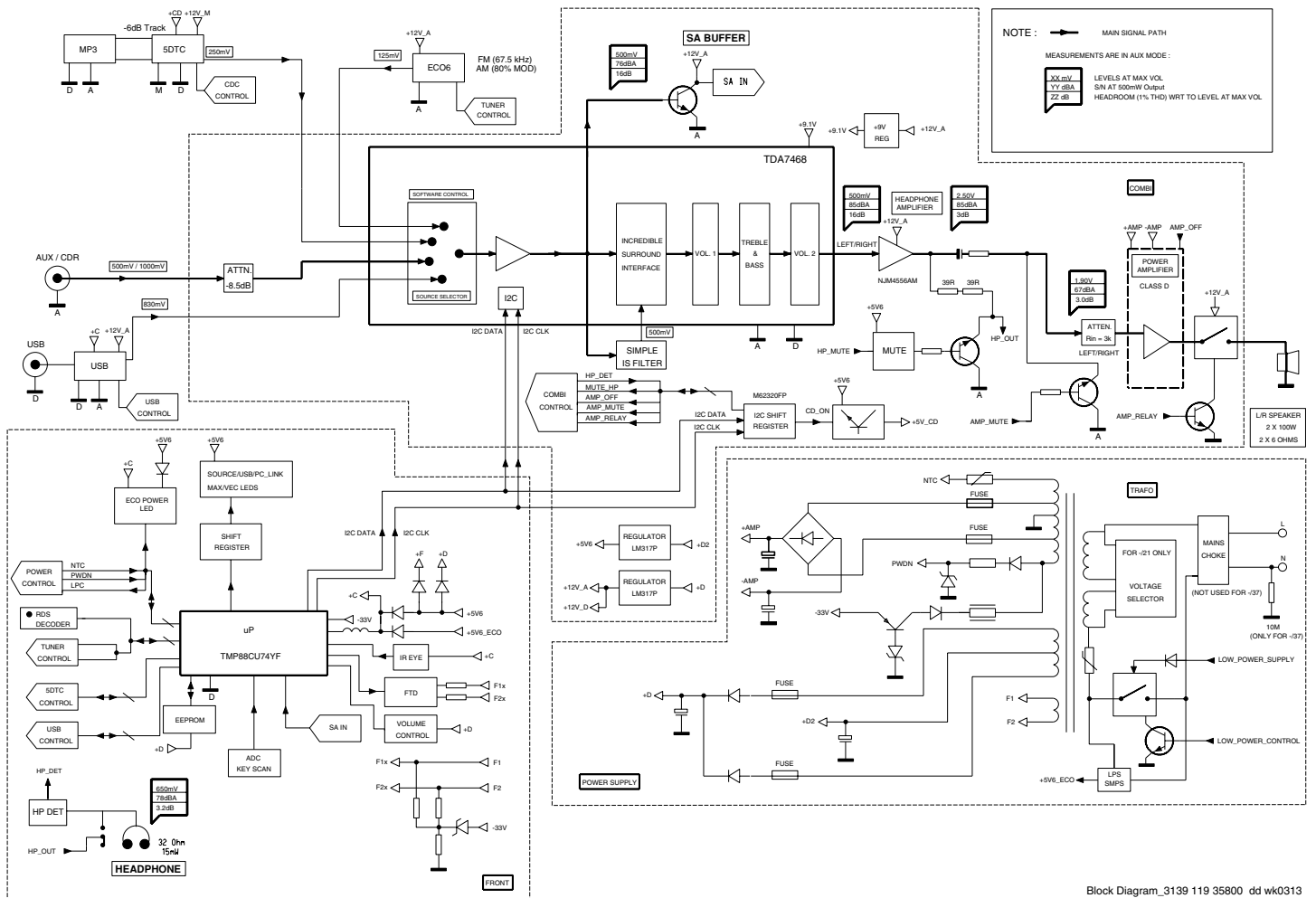

Block Diagram\_3139 119 35800 dd wk0313

SET WIRING DIAGRAM

5-1

5-1

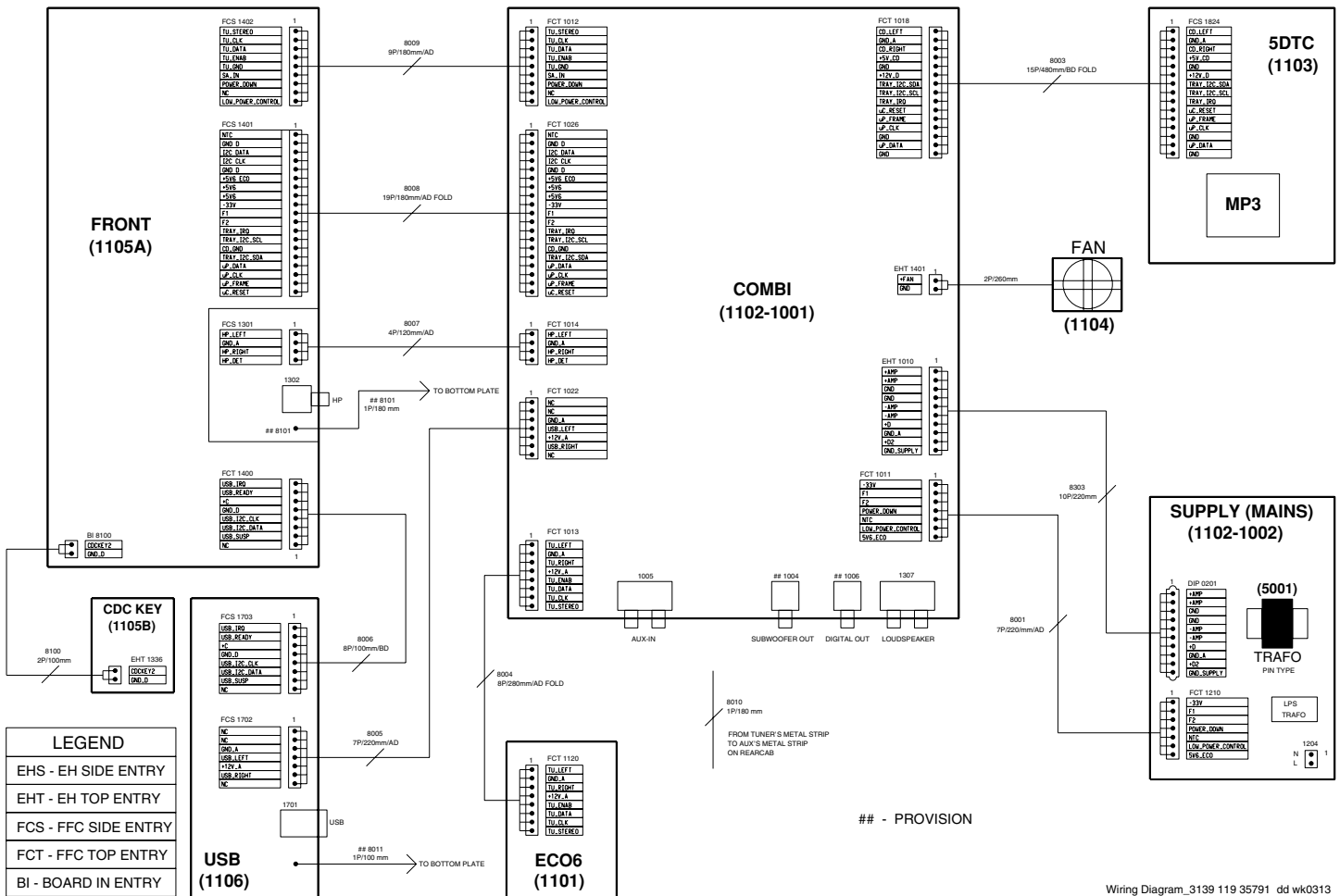



# FRONT BOARD

## TABLE OF CONTENTS

FTD Display Pin Connection ..... 6-1  
 Front Board - Component layout ..... 6-2  
 Front Board - Chip layout ..... 6-3  
 Front Board - Circuit diagram (Part 1) ..... 6-4  
 Front Board - Circuit diagram (Part 2) ..... 6-5  
 Front Board - Circuit diagram (Part 3) ..... 6-6  
 CDC Key Part - Layout & Circuit diagram ..... 6-7  
 Variant Table ..... 6-7  
 Electrical parts list ..... 6-8

## FTD DISPLAY PIN CONNECTION

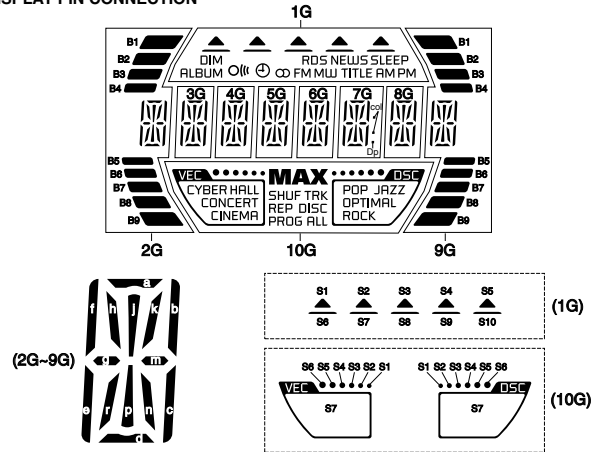

	1G	2G	3G	4G	5G	6G	7G	8G	9G	10G
P1	S1	a	a	a	a	a	a	a	a	S1
P2	S2	h	h	h	h	h	h	h	h	S2
P3	S3	J, P	J, P	J, P	J, P	J, P	J, P	J, P	J, P	S3
P4	S4	k	k	k	k	k	k	k	k	S4
P5	S5	b	b	b	b	b	b	b	b	S5
P6	S6	f	f	f	f	f	f	f	f	S6
P7	S7	m	m	m	m	m	m	m	m	S7
P8	S8	g	g	g	g	g	g	g	g	<b>MAX</b>
P9	S9	c	c	c	c	c	c	c	c	SHUF
P10	S10	e	e	e	e	e	e	e	e	TRK
P11	DIM	r	r	r	r	r	r	r	r	REP
P12	ALBUM	n	n	n	n	n	n	n	n	DISC
P13	O(k)	d	d	d	d	d	d	d	d	PROG
P14	Ⓞ	B1	-	-	-	-	col	-	B1	ALL
P15	Ⓞ	B2	-	-	-	-	Dp	-	B2	CYBER
P16	RDS	B3	-	-	-	-	-	-	B3	HALL
P17	NEWS	B4	-	-	-	-	-	-	B4	CONCERT
P18	SLEEP	B5	-	-	-	-	-	-	B5	CINEMA
P19	FM	B6	-	-	-	-	-	-	B6	POP
P20	MW	B7	-	-	-	-	-	-	B7	JAZZ
P21	TITLE	B8	-	-	-	-	-	-	B8	OPTIMAL
P22	AM	B9	-	-	-	-	-	-	B9	ROCK
P23	PM	-	-	-	-	-	-	-	-	-

FRONT BOARD - CIRCUIT DIAGRAM (Part 1)

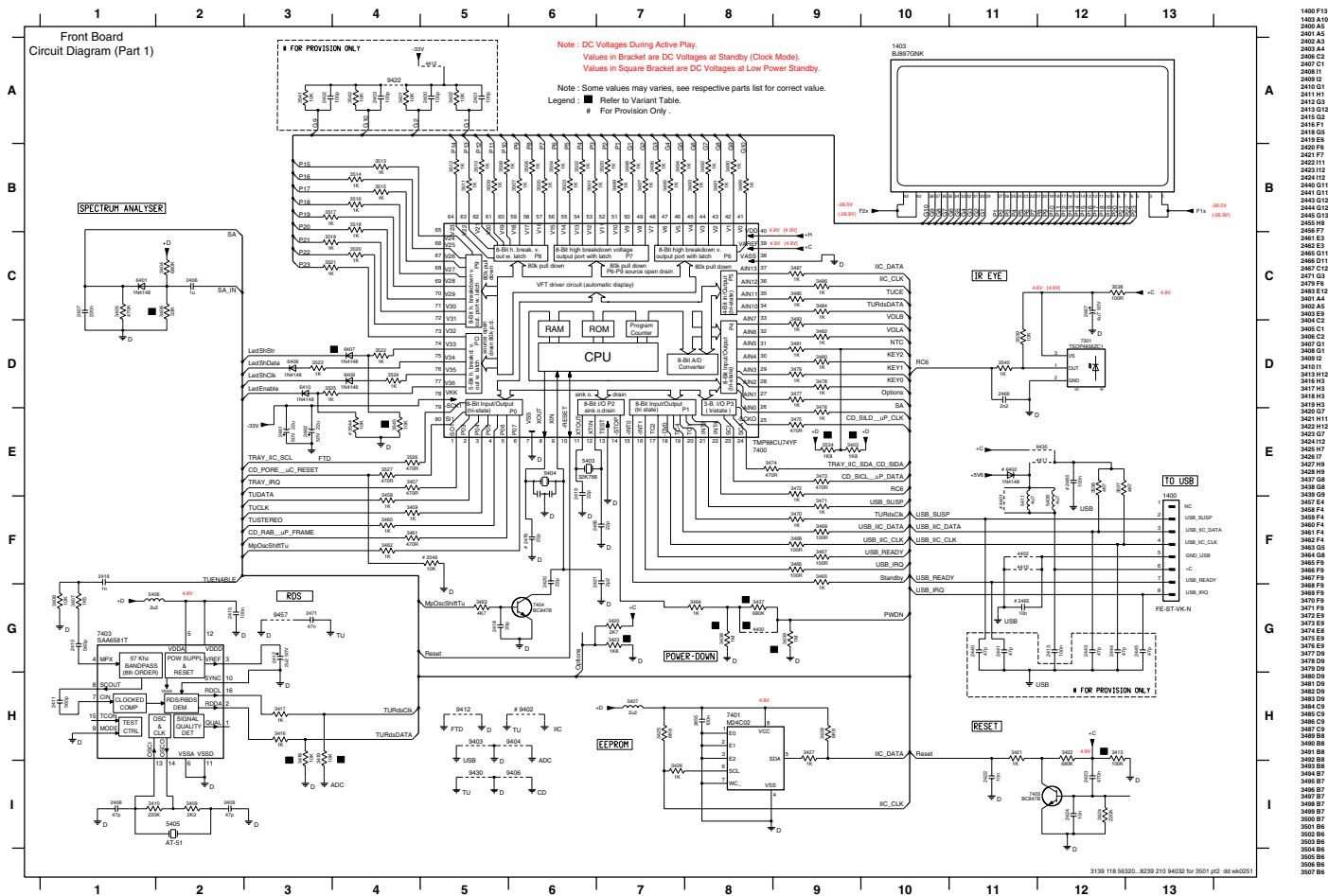

1400 F13	3008 B5
1401 B10	3009 B5
2400 A3	3010 B5
2401 A5	3011 B5
2402 A3	3012 B5
2403 A4	3013 B4
2404 C2	3014 B4
2405 C1	3015 B4
2406 B1	3016 B4
2407 B2	3017 B4
2410 G1	3018 B4
2411 H2	3019 C3
2412 G3	3020 C4
2413 G2	3021 C3
2414 G2	3022 D4
2415 E5	3023 D3
2416 G5	3024 D4
2417 E5	3025 E4
2420 F5	3026 E4
2421 F7	3027 E4
2422 H1	3028 E9
2423 H2	3029 E9
2424 H2	3030 E12
2441 G1	3030 D11
2442 G1	3040 D12
2443 G1	3040 D11
2444 G1	3041 A3
2445 G1	3042 A4
2450 H8	3044 E4
2451 F7	3045 E4
2452 E5	3046 F5
2453 E5	3046 F5
2454 G1	3046 F5
2455 G1	3046 F5
2456 G1	3046 F5
2457 G1	3046 F5
2458 G1	3046 F5
2459 G1	3046 F5
2460 G1	3046 F5
2461 G1	3046 F5
2462 G1	3046 F5
2463 G1	3046 F5
2464 G1	3046 F5
2465 G1	3046 F5
2466 G1	3046 F5
2467 G1	3046 F5
2468 G1	3046 F5
2469 G1	3046 F5
2470 G1	3046 F5
2471 G1	3046 F5
2472 G1	3046 F5
2473 G1	3046 F5
2474 G1	3046 F5
2475 G1	3046 F5
2476 G1	3046 F5
2477 G1	3046 F5
2478 G1	3046 F5
2479 G1	3046 F5
2480 G1	3046 F5
2481 G1	3046 F5
2482 G1	3046 F5
2483 G1	3046 F5
2484 G1	3046 F5
2485 G1	3046 F5
2486 G1	3046 F5
2487 G1	3046 F5
2488 G1	3046 F5
2489 G1	3046 F5
2490 G1	3046 F5
2491 G1	3046 F5
2492 G1	3046 F5
2493 G1	3046 F5
2494 G1	3046 F5
2495 G1	3046 F5
2496 G1	3046 F5
2497 G1	3046 F5
2498 G1	3046 F5
2499 G1	3046 F5
2500 G1	3046 F5

FRONT BOARD - CIRCUIT DIAGRAM (Part 2)

1301 A7	1306 D7	1311 F8	1316 F9	1321 F7	1326 D8	2303 B6	2308 F5	2459 B4	3300 A1	3307 E2	3312 E3	3317 A6	3322 C7	3328 C8	3334 F9	3339 F7	3344 F8	3529 C2	4406 D1	5401 B3	6303 F1	7406 A2	8101 B7
1302 A9	1307 D6	1312 E6	1317 E9	1322 F7	1327 D8	2304 B8	2309 D5	2460 B4	3301 B1	3308 E2	3313 E3	3318 C5	3323 D5	3329 D7	3335 E5	3340 F7	3345 C6	3530 C2	4407 D1	5410 A3	6304 F2	7407 B3	8105 B3
1303 A5	1308 D6	1313 F6	1318 E9	1323 F8	1328 F9	2305 B6	2310 D8	2460 F4	3304 E1	3309 E2	3314 E4	3319 C6	3324 D6	3330 D8	3336 F6	3341 F7	3346 E3	3531 C3	5300 A8	6305 F1	7408 F3		
1304 D7	1309 F6	1314 E7	1319 E9	1324 F7	1330 E6	2306 B8	2457 D2	2470 F3	3305 E1	3310 E2	3315 E4	3320 C7	3325 D6	3331 D8	3337 F6	3342 F8	3347 E4	4403 F3	5301 B8	6301 B2	6306 E3	7409 F4	
1305 D7	1310 F6	1315 F8	1320 E8	1325 E7	2302 B6	2307 E5	2458 D2	2473 C1	3306 E1	3311 E3	3316 A6	3321 C7	3326 D7	3332 D9	3338 F6	3343 F8	3528 C1	4404 F4	5302 B8	6302 F1	6307 E4	8100 C9	

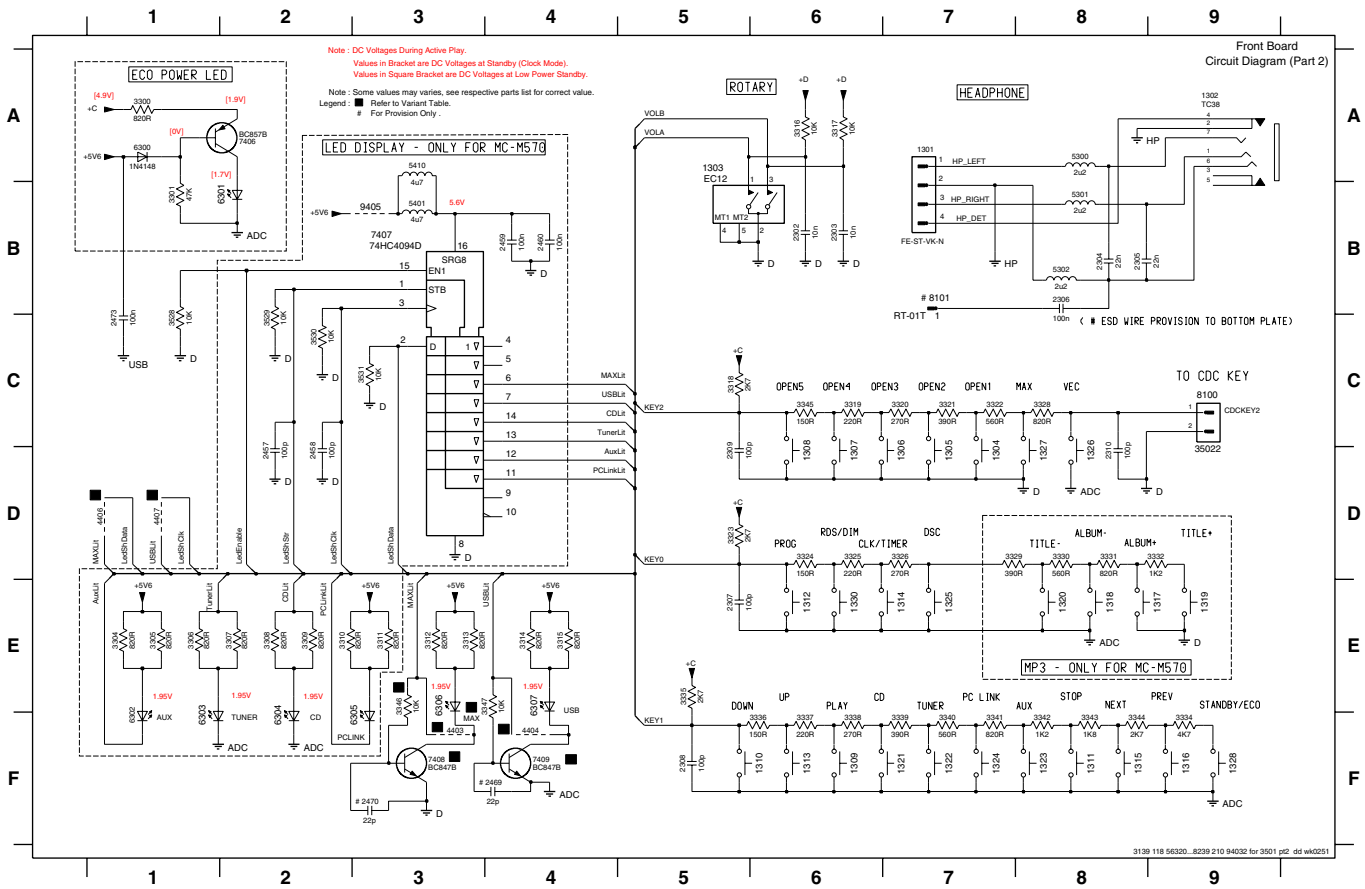



**CDC KEY BOARD - COMPONENT LAYOUT**

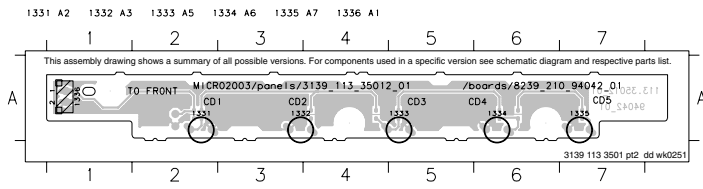

**CDC KEY BOARD - CHIP LAYOUT**

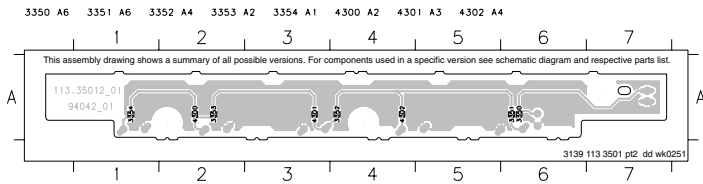

**CDC KEY BOARD - CIRCUIT DIAGRAM**

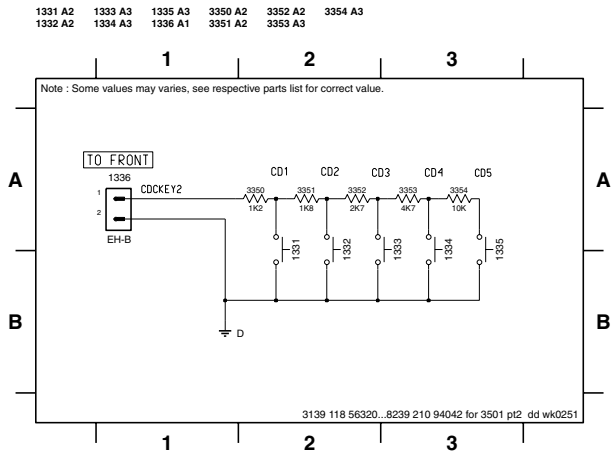

**VARIANT TABLE**

Model / Version Item No.	MC-500/22 MC-500/25	MC-500/30 MC-500/33 MC-500/37	MC-M570/22	MC-M570/21 MC-M570/33 MC-M570/37
3346	10K	10K	—	—
3347	10K	10K	—	—
3413	100K	—	100K	100K
3403 / 3534	1K8	1K8	—	—
3406	33K	33K	15K	15K
3418	—	10K	—	10K
3419	—	10K	—	10K
3423	1K8	—	1K8	1K8
3437	680K	680K	—	—
3438	1M	1M	2M2	2M2
3439	1M	1M	—	—
3452	—	—	470R	470R
3545	10K	10K	—	—
3547	39K	—	—	—
4400	—	—	X	X
4403	—	—	X	X
4404	—	—	X	X
4406	X	X	—	—
4407	X	X	—	—
4408	X	X	—	—
6405	X	—	X	X
6407	—	—	X	X
7408	X	X	—	—
7409	X	X	—	—

X - Item in use.

## ELECTRICAL PARTS LIST - FRONT BOARD

## MISCELLANEOUS

1301	4822 265 11183	Flex Connector 4P
1302	2422 026 05059	Headphone Socket
1303	2422 129 16708	Rotary Encoder 24P
1304	4822 276 13775	Tact Switch
1305	4822 276 13775	Tact Switch
1306	4822 276 13775	Tact Switch
1307	4822 276 13775	Tact Switch
1308	4822 276 13775	Tact Switch
1309	4822 276 13775	Tact Switch
1310	4822 276 13775	Tact Switch
1311	4822 276 13775	Tact Switch
1312	4822 276 13775	Tact Switch
1313	4822 276 13775	Tact Switch
1314	4822 276 13775	Tact Switch
1315	4822 276 13775	Tact Switch
1316	4822 276 13775	Tact Switch
1317	4822 276 13775	Tact Switch
1318	4822 276 13775	Tact Switch
1319	4822 276 13775	Tact Switch
1320	4822 276 13775	Tact Switch
1321	4822 276 13775	Tact Switch
1322	4822 276 13775	Tact Switch
1323	4822 276 13775	Tact Switch
1324	4822 276 13775	Tact Switch
1325	4822 276 13775	Tact Switch
1326	4822 276 13775	Tact Switch
1327	4822 276 13775	Tact Switch
1328	4822 276 13775	Tact Switch
1330	4822 276 13775	Tact Switch
1331	4822 276 13775	Tact Switch
1332	4822 276 13775	Tact Switch
1333	4822 276 13775	Tact Switch
1334	4822 276 13775	Tact Switch
1335	4822 276 13775	Tact Switch
1400	4822 265 11535	Flex Connector 8P
1401	4822 265 11545	Flex Connector 19P
1402	4822 265 11531	Flex Connector 9P
1403	3139 110 53291	FTD (BJ897GNK)

## CAPACITORS

2302	5322 126 11583	10nF 10% 50V
2303	5322 126 11583	10nF 10% 50V
2304	4822 126 14494	22nF 10% 25V
2305	4822 126 14494	22nF 10% 25V
2306	2238 586 59812	100nF 50V
2307	2020 552 94427	100pF 5% 50V
2308	2020 552 94427	100pF 5% 50V
2309	2020 552 94427	100pF 5% 50V
2310	2020 552 94427	100pF 5% 50V
2406	3198 017 41050	1uF 10V
2407	4822 126 13879	220nF +80/-20% 16V
2408	4822 126 11785	47pF 5% 50V /22

2409	4822 126 11785	47pF 5% 50V /22
2410	4822 126 14249	560pF 10% 50V /22
2411	4822 126 14249	560pF 10% 50V /22
2412	4822 124 22652	2,2uF 20% 50V /22
2413	2238 586 59812	100nF 50V
2415	2238 586 59812	100nF 50V /22
2416	5322 126 11578	1nF 10% 50V /22
2418	2222 867 15339	33pF 5% 50V
2419	4822 122 33761	22pF 5% 50V
2420	4822 122 33761	22pF 5% 50V
2421	4822 126 14223	2,2pF 50V
2422	5322 126 11583	10nF 10% 50V
2423	3198 017 44740	470nF 10V
2424	5322 126 11583	10nF 10% 50V
2425	4822 124 81286	47uF 20% 16V
2426	4822 124 12032	4,7uF 20% 50V
2427	4822 124 12032	4,7uF 20% 50V
2428	4822 124 12032	4,7uF 20% 50V
2429	4822 124 12032	4,7uF 20% 50V
2432	2020 552 94427	100pF 5% 50V
2437	2238 586 59812	100nF 50V
2438	4822 124 81286	47uF 20% 16V
2439	4822 124 81286	47uF 20% 16V
2455	2238 586 59812	100nF 50V
2456	4822 122 33761	22pF 5% 50V
2457	2020 552 94427	100pF 5% 50V
2458	2020 552 94427	100pF 5% 50V
2459	2238 586 59812	100nF 50V
2460	2238 586 59812	100nF 50V
2461	3198 028 52290	22uF 20% 50V
2462	3198 028 52290	22uF 20% 50V
2463	2238 586 59812	100nF 50V
2464	2238 586 59812	100nF 50V
2466	4822 126 14238	2,2nF 50V
2467	4822 124 12032	4,7uF 20% 50V
2468	2238 586 59812	100nF 50V
2471	3198 017 34730	47nF 16V /22
2473	2238 586 59812	100nF 50V
2478	2238 586 59812	100nF 50V
2482	2238 586 59812	100nF 50V

## RESISTORS

3300	4822 116 52231	820R 5% 0,5W
3301	4822 117 12925	47k 1% 0,063W
3304	4822 117 12968	820R 5% 0,62W
3305	4822 117 12968	820R 5% 0,62W
3306	4822 117 12968	820R 5% 0,62W
3307	4822 117 12968	820R 5% 0,62W
3308	4822 117 12968	820R 5% 0,62W
3309	4822 117 12968	820R 5% 0,62W
3310	4822 117 12968	820R 5% 0,62W
3311	4822 117 12968	820R 5% 0,62W

## ELECTRICAL PARTS LIST - FRONT BOARD

3312	4822 117 12968	820R 5% 0,62W
3313	4822 117 12968	820R 5% 0,62W
3314	4822 117 12968	820R 5% 0,62W
3315	4822 117 12968	820R 5% 0,62W
3316	4822 051 30103	10k 5% 0,062W
3317	4822 051 30103	10k 5% 0,062W
3318	4822 051 30272	2k7 5% 0,062W
3319	4822 051 30221	220R 5% 0,062W
3320	4822 051 30271	270R 5% 0,062W
3321	4822 051 30391	390R 5% 0,062W
3322	4822 051 30561	560R 5% 0,062W
3323	4822 051 30272	2k7 5% 0,062W
3324	4822 051 30151	150R 5% 0,062W
3325	4822 051 30221	220R 5% 0,062W
3326	4822 116 83876	270R 5% 0,5W
3328	4822 117 12968	820R 5% 0,62W
3329	4822 051 30391	390R 5% 0,062W
3330	4822 116 52226	560R 5% 0,5W
3331	4822 116 52231	820R 5% 0,5W
3332	4822 116 52207	1k2 5% 0,5W
3334	4822 116 52283	4k7 5% 0,5W
3335	4822 051 30272	2k7 5% 0,062W
3336	4822 051 30151	150R 5% 0,062W
3337	4822 051 30221	220R 5% 0,062W
3338	4822 116 83876	270R 5% 0,5W
3339	4822 051 30391	390R 5% 0,062W
3340	4822 051 30561	560R 5% 0,062W
3341	4822 117 12968	820R 5% 0,62W
3342	4822 117 11817	1k2 1% 1/16W
3343	4822 117 12903	1k8 1% 0,063W
3344	4822 051 30272	2k7 5% 0,062W
3345	4822 051 30151	150R 5% 0,062W
3350	4822 117 11817	1k2 1% 1/16W
3351	4822 117 12903	1k8 1% 0,063W
3352	4822 051 30272	2k7 5% 0,062W
3353	4822 051 30472	4k7 5% 0,062W
3354	4822 051 30103	10k 5% 0,062W
3404	4822 051 30684	680k 5% 0,062W
3405	4822 051 30474	470k 5% 0,062W
3406	4822 051 30153	15k 5% 0,062W
3407	4822 051 30152	1k5 5% 0,062W /22
3408	4822 051 30103	10k 5% 0,062W /22
3409	4822 051 30222	2k2 5% 0,062W /22
3410	4822 117 12891	220k 1% /22
3413	4822 117 13632	100k 1% 0,62W
3416	4822 051 30102	1k 5% 0,062W /22
3417	4822 051 30102	1k 5% 0,062W /22
3418	4822 050 21003	10k 1% 0,6W /21/21M/37
3419	4822 051 30103	10k 5% 0,062W /21/21M/37
3420	4822 051 30272	2k7 5% 0,062W
3421	4822 051 30102	1k 5% 0,062W
3422	4822 051 30684	680k 5% 0,062W
3423	4822 116 52249	1k8 5% 0,5W
3424	4822 117 12891	220k 1%
3425	4822 051 30682	6k8 5% 0,062W
3426	4822 051 30102	1k 5% 0,062W
3427	4822 051 30102	1k 5% 0,062W
3428	4822 051 30682	6k8 5% 0,062W
3429	4822 116 83872	220R 5% 0,5W
3430	4822 052 10688	Δ 6R8 5% 0,33W
3431	4822 116 83872	220R 5% 0,5W
3432	4822 052 10109	Δ 10R 5% 0,33W
3433	4822 116 52257	22k 5% 0,5W
3438	3198 021 32250	2M2 5%
3440	4822 051 30103	10k 5% 0,062W
3441	4822 051 30103	10k 5% 0,062W
3442	4822 051 30103	10k 5% 0,062W
3443	4822 051 30102	1k 5% 0,062W
3444	4822 051 30102	1k 5% 0,062W
3445	4822 051 30102	1k 5% 0,062W
3447	4822 051 30103	10k 5% 0,062W
3448	4822 116 83872	220R 5% 0,5W
3449	4822 116 83872	220R 5% 0,5W
3450	4822 051 30471	470R 5% 0,062W
3451	4822 051 30471	470R 5% 0,062W
3452	4822 051 30471	470R 5% 0,062W
3453	4822 116 83883	470R 5% 0,5W
3454	4822 116 83883	470R 5% 0,5W
3455	4822 051 30471	470R 5% 0,062W
3456	4822 051 30471	470R 5% 0,062W
3457	4822 051 30471	470R 5% 0,062W
3458	4822 051 30102	1k 5% 0,062W
3459	4822 051 30102	1k 5% 0,062W
3460	4822 051 30102	1k 5% 0,062W
3461	4822 051 30471	470R 5% 0,062W
3462	4822 051 30102	1k 5% 0,062W
3463	4822 051 30472	4k7 5% 0,062W
3464	4822 051 30102	1k 5% 0,062W
3465	4822 051 30102	1k 5% 0,062W
3466	4822 116 52175	100R 5% 0,5W
3467	4822 116 52175	100R 5% 0,5W
3468	4822 116 52175	100R 5% 0,5W
3469	4822 116 52175	100R 5% 0,5W
3470	4822 050 11002	1k 1% 0,4W
3471	4822 050 11002	1k 1% 0,4W
3472	4822 051 30102	1k 5% 0,062W
3473	4822 051 30471	470R 5% 0,062W
3474	4822 051 30471	470R 5% 0,062W
3475	4822 051 30471	470R 5% 0,062W
3476	4822 051 30102	1k 5% 0,062W
3477	4822 051 30102	1k 5% 0,062W
3478	4822 051 30102	1k 5% 0,062W
3479	4822 051 30102	1k 5% 0,062W
3480	4822 051 30102	1k 5% 0,062W

**ELECTRICAL PARTS LIST - FRONT BOARD****RESISTORS**

3481	4822 051 30102	1k 5% 0,062W	3533	4822 052 10109	△ 10R 5% 0,33W
3482	4822 050 11002	1k 1% 0,4W	3536	4822 051 30472	4k7 5% 0,062W
3483	4822 050 11002	1k 1% 0,4W	3537	4822 051 30472	4k7 5% 0,062W
3484	4822 051 30102	1k 5% 0,062W	3538	4822 116 52175	100R 5% 0,5W
3485	4822 051 30102	1k 5% 0,062W	3539	4822 051 30103	10k 5% 0,062W
3486	4822 051 30102	1k 5% 0,062W	3540	4822 051 30102	1k 5% 0,062W
3487	4822 051 30102	1k 5% 0,062W	3543	4822 051 30102	1k 5% 0,062W
3489	4822 051 30102	1k 5% 0,062W	4300	4822 051 30008	0R Jumper 0603
3490	4822 051 30102	1k 5% 0,062W	4301	4822 051 30008	0R Jumper 0603
3491	4822 051 30102	1k 5% 0,062W	4302	4822 051 30008	0R Jumper 0603
3492	4822 051 30102	1k 5% 0,062W	4400	4822 051 30008	0R Jumper 0603
3493	4822 051 30102	1k 5% 0,062W	4402	4822 051 30008	0R Jumper 0603
3494	4822 051 30102	1k 5% 0,062W	4403	4822 051 30008	0R Jumper 0603
3495	4822 051 30102	1k 5% 0,062W	4404	4822 051 30008	0R Jumper 0603
3496	4822 051 30102	1k 5% 0,062W	4410	4822 051 30008	0R Jumper 0603
3497	4822 051 30102	1k 5% 0,062W	4411	4822 051 30008	0R Jumper 0603
3498	4822 051 30102	1k 5% 0,062W	4420	4822 051 30008	0R Jumper 0603
3499	4822 051 30102	1k 5% 0,062W	4421	4822 051 30008	0R Jumper 0603
3500	4822 051 30102	1k 5% 0,062W	4422	4822 051 30008	0R Jumper 0603
3501	4822 051 30102	1k 5% 0,062W	4423	4822 051 30008	0R Jumper 0603
3502	4822 051 30102	1k 5% 0,062W	4424	4822 051 30008	0R Jumper 0603
3503	4822 051 30102	1k 5% 0,062W	4425	4822 051 30008	0R Jumper 0603
3504	4822 051 30102	1k 5% 0,062W	4426	4822 051 30008	0R Jumper 0603
3505	4822 051 30102	1k 5% 0,062W	4427	4822 051 30008	0R Jumper 0603
3506	4822 051 30102	1k 5% 0,062W	4428	4822 051 30008	0R Jumper 0603
3507	4822 051 30102	1k 5% 0,062W	4429	4822 051 30008	0R Jumper 0603
3508	4822 051 30102	1k 5% 0,062W	4430	4822 051 30008	0R Jumper 0603
3509	4822 051 30102	1k 5% 0,062W	4431	4822 051 30008	0R Jumper 0603
3510	4822 051 30102	1k 5% 0,062W	4432	4822 051 30008	0R Jumper 0603
3511	4822 051 30102	1k 5% 0,062W	4433	4822 051 30008	0R Jumper 0603
3512	4822 051 30102	1k 5% 0,062W	4434	4822 051 30008	0R Jumper 0603
3513	4822 051 30102	1k 5% 0,062W	4435	4822 051 30008	0R Jumper 0603
3514	4822 051 30102	1k 5% 0,062W	4436	4822 051 30008	0R Jumper 0603
3515	4822 051 30102	1k 5% 0,062W	4437	4822 051 30008	0R Jumper 0603
3516	4822 051 30102	1k 5% 0,062W	4438	4822 051 30008	0R Jumper 0603
3517	4822 051 30102	1k 5% 0,062W	4439	4822 051 30008	0R Jumper 0603
3518	4822 051 30102	1k 5% 0,062W	4440	4822 051 30008	0R Jumper 0603
3519	4822 051 30102	1k 5% 0,062W	4441	4822 051 30008	0R Jumper 0603
3520	4822 051 30102	1k 5% 0,062W	4442	4822 051 30008	0R Jumper 0603
3521	4822 051 30102	1k 5% 0,062W	4443	4822 051 30008	0R Jumper 0603
3522	4822 051 30102	1k 5% 0,062W	4444	4822 051 30008	0R Jumper 0603
3523	4822 051 30102	1k 5% 0,062W	4445	4822 051 30008	0R Jumper 0603
3524	4822 051 30102	1k 5% 0,062W	4446	4822 051 30008	0R Jumper 0603
3525	4822 051 30102	1k 5% 0,062W	4447	4822 051 30008	0R Jumper 0603
3526	4822 051 30471	470R 5% 0,062W	4448	4822 051 30008	0R Jumper 0603
3527	4822 051 30471	470R 5% 0,062W	4449	4822 051 30008	0R Jumper 0603
3528	4822 051 30103	10k 5% 0,062W	4450	4822 051 30008	0R Jumper 0603
3529	4822 051 30103	10k 5% 0,062W	4451	4822 051 30008	0R Jumper 0603
3530	4822 051 30103	10k 5% 0,062W	4452	4822 051 30008	0R Jumper 0603
3531	4822 051 30103	10k 5% 0,062W	4453	4822 051 30008	0R Jumper 0603
3532	4822 052 10688	△ 6R8 5% 0,33W	4454	4822 051 30008	0R Jumper 0603

**ELECTRICAL PARTS LIST - FRONT BOARD**

---

**RESISTORS**

---

4455	4822 051 30008	0R Jumper 0603	7406	4822 130 60373	BC857B
4456	4822 051 30008	0R Jumper 0603	7407	4822 209 15449	74HC4094D
4457	4822 051 30008	0R Jumper 0603			
4458	4822 051 30008	0R Jumper 0603			
4459	4822 051 30008	0R Jumper 0603			
4460	4822 051 30008	0R Jumper 0603			
4461	4822 051 30008	0R Jumper 0603			
4462	4822 051 30008	0R Jumper 0603			

Note : Only the parts mentioned in this list are normal service spare parts.

**COILS & FILTERS**

---

5300	3198 018 52280	Coil 2,2uH 10%
5301	3198 018 52280	Coil 2,2uH 10%
5302	3198 018 52280	Coil 2,2uH 10%
5401	3198 018 54780	Coil 4,7uH 10%
5402	3198 018 54780	Coil 4,7uH 10%
5403	2422 543 01069	RES XTL 32,768kHz
5404	5322 242 73686	RES CER 12MHz
5405	4822 242 11033	RES XTL 4,332MHz /22
5406	3198 018 52280	Coil 2,2uH 10% /22
5407	3198 018 52280	Coil 2,2uH 10%
5408	3198 018 54780	Coil 4,7uH 10%
5409	3198 018 54780	Coil 4,7uH 10%
5410	3198 018 54780	Coil 4,7uH 10%
5411	3198 018 54780	Coil 4,7uH 10%

**DIODES**

---

6300	4822 130 30621	1N4148
6301	9322 179 76676	LED VS LTL-816EELC
6302	9322 178 15676	LED VS LTL-8166FTNN
6303	9322 178 15676	LED VS LTL-8166FTNN
6304	9322 178 15676	LED VS LTL-8166FTNN
6305	9322 178 15676	LED VS LTL-8166FTNN
6306	9322 178 15676	LED VS LTL-8166FTNN
6307	9322 178 15676	LED VS LTL-8166FTNN
6401	4822 130 30621	1N4148
6403	4822 130 31878	1N4003G
6404	4822 130 34278	BZX79-B6V8
6405	4822 130 31878	1N4003G
6406	4822 130 31878	1N4003G
6407	4822 130 30621	1N4148
6408	4822 130 30621	1N4148
6409	4822 130 30621	1N4148
6410	4822 130 30621	1N4148

**TRANSISTORS & INTEGRATED CIRCUITS**

---

7301	9322 185 97667	IR Receiver TSOP4836ZC1
7400	3139 110 53371	TMP88CU74YF - '570S53371'
7401	9322 145 26668	M24C02-WMN6
7403	9352 686 05118	SAA6581T /22
7404	5322 130 60159	BC847B
7405	5322 130 60159	BC847B



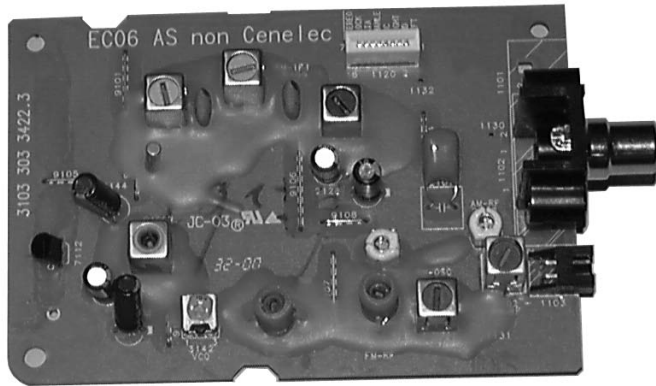

# ECO6 Tuner Board

version: **SYSTEMS non-CENELEC**

## BLOCK DIAGRAM

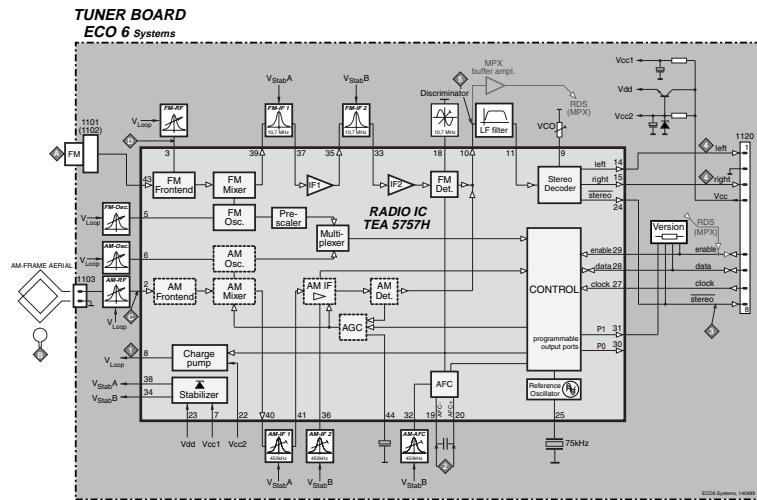

### TABLE OF CONTENTS

Blockdiagram .....	7A-1
Schematic Diagram .....	7A-2
Component Layout .....	7A-3
Adjustment table .....	7A-3
Electrical Partlist .....	7A-4

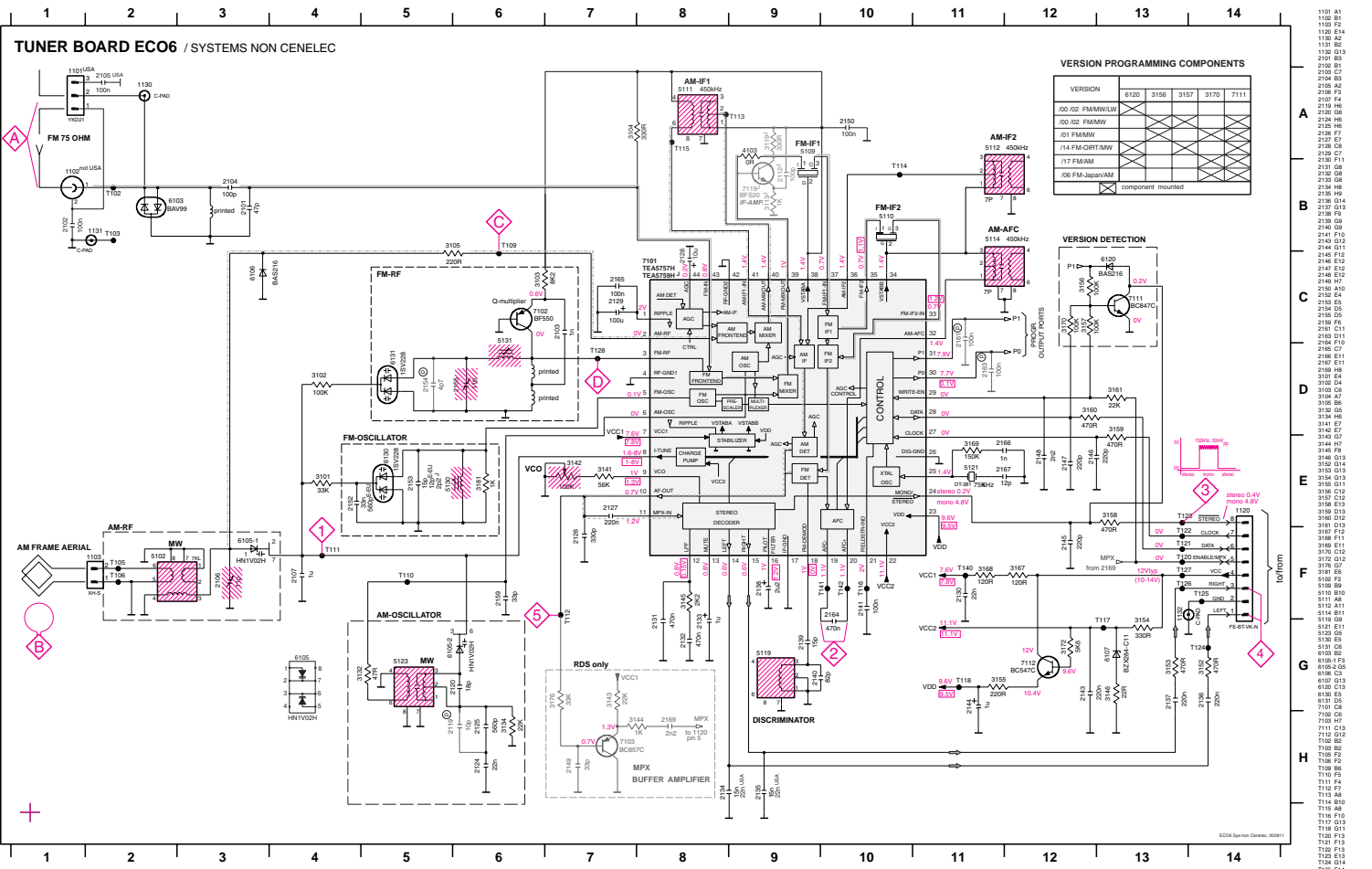

VERSION PROGRAMMING COMPONENTS

VERSION	6120	3156	3157	3170	7111
100.02 FM/AM/LW					
100.02 FM/MW					
101 FM/MW					
114 FM-CR/AM					
117 FM/AM					
126 FM-AM/AM					

component mounted

VERSION DETECTION

VERSION	6120	3156	3157	3170	7111
100.02 FM/AM/LW					
100.02 FM/MW					
101 FM/MW					
114 FM-CR/AM					
117 FM/AM					
126 FM-AM/AM					

**LEGEND**  
 Ⓞ for provision only  
 USA ... for USA version only  
 E-EU ... for East European version only  
 J ... for Japanese version only

~V FM mode stereo  
 ~V MW mode  
 ~V LW mode  
 voltages measured while set is tuned to a strong transmitter

**Signal path**  
 --- FM  
 --- AM  
 --- (Audio Frequency)  
 ⇨ AF - left/right

- 1101 A1
- 1102 F2
- 1103 A2
- 1104 B3
- 1105 B5
- 1106 G3
- 1107 B3
- 1108 E1
- 1109 E2
- 1110 A2
- 1111 B2
- 1112 F4
- 1113 F4
- 1114 B2
- 1115 B6
- 1116 B6
- 1117 F4M
- 1118 C7
- 1119 C8
- 1120 B8
- 1121 B8
- 1122 F11
- 1123 C8
- 1124 B8
- 1125 F2
- 1126 F2
- 1127 F4
- 1128 F4
- 1129 F4
- 1130 F4
- 1131 F4
- 1132 F4
- 1133 F4
- 1134 F4
- 1135 F4
- 1136 F4
- 1137 F4
- 1138 F4
- 1139 F4
- 1140 F4
- 1141 F4
- 1142 F4
- 1143 F4
- 1144 F4
- 1145 F4
- 1146 F4
- 1147 F4
- 1148 F4
- 1149 F4
- 1150 F4
- 1151 F4
- 1152 F4
- 1153 F4
- 1154 F4
- 1155 F4
- 1156 F4
- 1157 F4
- 1158 F4
- 1159 F4
- 1160 F4
- 1161 F4
- 1162 F4
- 1163 F4
- 1164 F4
- 1165 F4
- 1166 F4
- 1167 F4
- 1168 F4
- 1169 F4
- 1170 F4
- 1171 F4
- 1172 F4
- 1173 F4
- 1174 F4
- 1175 F4
- 1176 F4
- 1177 F4
- 1178 F4
- 1179 F4
- 1180 F4
- 1181 F4
- 1182 F4
- 1183 F4
- 1184 F4
- 1185 F4
- 1186 F4
- 1187 F4
- 1188 F4
- 1189 F4
- 1190 F4
- 1191 F4
- 1192 F4
- 1193 F4
- 1194 F4
- 1195 F4
- 1196 F4
- 1197 F4
- 1198 F4
- 1199 F4
- 1200 F4

©2006 Philips Consumer Electronics

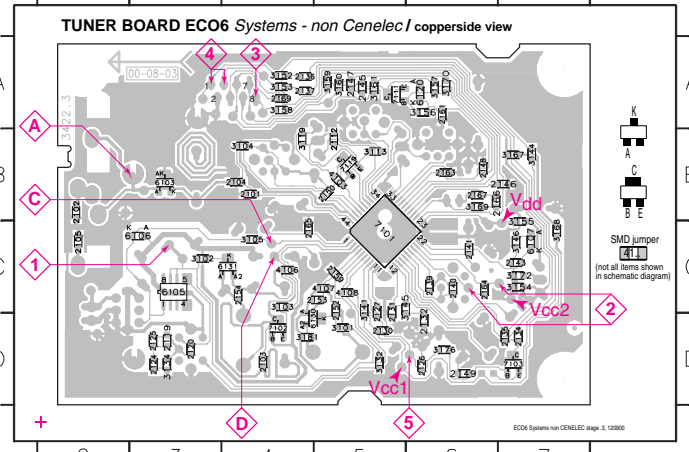
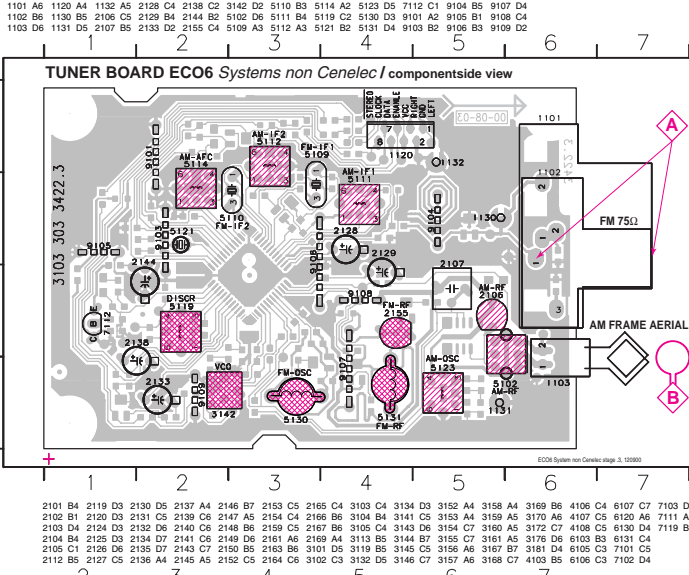

These assembly drawings show a summary of all possible versions.  
For components used in a specific version see schematic diagram respectively partslist.

TUNER ADJUSTMENT TABLE (ECO6 FM/MW- and FM/MW/LW - versions with AM-frame aerial)

Waverange	Input frequency	Input	Tuned to	Adjust	Output	Scope/Voltmeter
<b>VARICAP ALIGNMENT</b>						
<b>FM</b> 87.5 - 108MHz (65.81 - 74, 87.5 - 108MHz)			108MHz	5130		8V ±0.2V
			87.5MHz (65.81MHz)	check		4.3V ±0.5V (1.2V ±0.5V)
<b>MW</b> FM/AM-version, 10kHz grid 530 - 1700kHz			1700kHz	5123		8V ±0.2V
			530kHz	check		1.1V ±0.4V
<b>FM/MW-version</b> , 9kHz grid 531 - 1602kHz			1602kHz	5123	1	6.9V ±0.2V
			531kHz	check		1.1V ±0.4V
<b>LW</b> 153 - 279kHz			279kHz	5122		8V ±0.2V
			153kHz	check		1.1V ±0.4V
<b>MW</b> FM/MW/LW-version, 9kHz grid 531 - 1602kHz			1602kHz	5123		8V ±0.2V
			531kHz	check		1.1V ±0.4V
<b>FM IF</b>						
<b>FM</b>	10.7MHz, 45mV continuous wave	D	IC 7101 21 shortcircuit to block AFC IC 7101 21 IC 7101 21	5119	2	0 ± 3 mV DC
<b>FM RF</b>						
<b>FM</b> 87.5 - 108MHz (65.81 - 74, 87.5 - 108MHz)	108MHz	A	108MHz	2155	4	MAX
	87.5MHz (65.81MHz)	mod=1kHz Δf=±22.5kHz	87.5MHz (65.81MHz)	5131		
<b>VCO</b>						
<b>FM</b>	98MHz, 1mV continuous wave	A	98MHz	3142	3	152kHz ±1kHz <sup>1)</sup>
<b>AM IF</b>						
<b>MW</b>	450kHz connect pin 6 of IC 7101 (AM Osc.) with 3.3kΩ to Vcc	C	IC 7101 36 100nF IC 7101 36 100nF see remark 2)	5111	5	symmetric
		C	IC 7101 36 100nF IC 7101 36 100nF see remark 2)	5112		
<b>AM AFC</b>		C	continuous wave V <sub>RF</sub> = 2mV	5114	2	0 ± 2 mV DC
<b>AM RF<sup>3)</sup></b>						
<b>MW<sup>4)</sup></b> FM/MW/LW- and FM/MW-version (9kHz grid)	1494kHz	B	1494kHz	2106	5	symmetric
	531 - 1602kHz		558kHz	5102		
<b>LW</b>	198kHz		198kHz	5103		
<b>MW</b> FM/AM-version, 10kHz grid	1500kHz		1500kHz	2106		
	530 - 1700kHz		560kHz	5102		

Use Service Testprogram. By selecting the TUNER TEST test frequencies will be stored as preset frequencies automatically.  
<sup>1)</sup> If sensitivity of frequency counter is too low adjust to max. channel separation (input signal: stereo left 90% + 9%, adjust output on right channel to minimum)  
<sup>2)</sup> RC network serves for damping the IF-filter while adjusting the other one.  
<sup>3)</sup> For AM RF adjustments the original frame antenna has to be used!  
<sup>4)</sup> MW has to be aligned before LW.

Repeat

**Electrical Partslist ECO6** SYSTEMS NON-CENELEC

MISCELLANEOUS				RESISTORS				
1101	2422 015 19376	SOCKET 2P CLICKFIT	USA only	3143	4822 051 20223	22kΩ	5% 0,1W	RDS only
1102	4822 267 10283	SOCKET COAX, IEC 75Ω	not USA	3144	4822 051 10102	1kΩ	2% 0,25W	RDS only
1103	4822 265 31184	JST CONNECTOR 2 POLE		3145	4822 117 11449	2,2kΩ	1% 0,1W	
1120	4822 265 11515	FFC SOCKET, 8P		3146	4822 051 20229	22Ω	5% 0,1W	
				3152	4822 051 20471	470Ω	5% 0,1W	
CAPACITORS				RESISTORS				
2101	4822 126 13692	47pF	1% 63V	3153	4822 051 20471	470Ω	5% 0,1W	
2102	4822 126 13838	100nF	10% 50V	3154	4822 117 13577	330Ω	1% 0,1W	
2103	5322 122 31647	1nF	10% 63V	3155	4822 117 11503	220Ω	5% 0,1W	
2104	5322 122 32531	100pF	5% 50V	3156	4822 117 10837	100kΩ	1% 0,1W	
2105	4822 126 13838	100nF	10% 50V	3157	4822 117 10837	100kΩ	1% 0,1W	
			USA only	3158	4822 051 20471	470Ω	5% 0,1W	
2106	2020 800 00191	3-11pF TRIMCAP, N450		3159	4822 051 20471	470Ω	5% 0,1W	
2107	4822 121 51319	1μF	20% 50V	3160	4822 051 20471	470Ω	5% 0,1W	
2120	4822 126 13689	18pF	1% 63V	3161	4822 051 20223	22kΩ	5% 0,1W	
2124	5322 122 32654	22nF	10% 63V	3167	4822 051 20121	120Ω	5% 0,1W	
2125	2020 552 96199	560pF	1% 50V					
				3168	4822 051 20121	120Ω	5% 0,1W	
2126	5322 122 31863	330pF	5% 50V	3169	4822 051 20154	150kΩ	5% 0,1W	
2127	4822 126 14076	220nF	20% 25V	3170	4822 117 10837	100kΩ	1% 0,1W	
2128	4822 124 40248	10μF	20% 63V	3172	4822 051 20562	5,6kΩ	5% 0,1W	
2129	4822 124 41584	100μF	20% 10V	3176	4822 051 20333	33kΩ	5% 0,1W	RDS only
2130	5322 122 32654	22nF	10% 63V					
				3181	4822 051 10102	1kΩ	2% 0,25W	
2131	4822 126 13482	470nF	20% 16V	4103	4822 051 20008	CHIP JUMPER 0805		
2132	4822 126 13482	470nF	20% 16V	4106	4822 051 20008	CHIP JUMPER 0805		
2133	4822 124 21913	1μF	20% 63V	4107	4822 051 20008	CHIP JUMPER 0805		
2134	4822 126 13188	15nF	5% 63V	4108	4822 051 20008	CHIP JUMPER 0805		
2134	5322 122 32654	22nF	10% 63V					
			not USA	COILS				
2135	4822 126 13188	15nF	5% 63V	5102	4822 157 71634	RF-COIL MW		
2135	5322 122 32654	22nF	10% 63V	5109	4822 242 70665	FM-IF FILTER 10,7MHz		
2136	4822 126 14076	220nF	20% 25V	5110	4822 242 70665	FM-IF FILTER 10,7MHz		
2137	4822 126 14076	220nF	20% 25V	5111	2422 549 44023	AM-IF FILTER 450kHz		
2138	4822 124 22652	2,2μF	20% 50V	5112	4822 157 70302	AM-IF FILTER 450kHz		
				5114	4822 157 70302	AM-IF FILTER 450kHz		
2139	4822 126 14236	15pF	5% 50V	5119	4822 157 11443	DISCRIMINATOR COIL		
2140	4822 126 13695	82pF	1% 63V	5121	4822 242 10261	QUARTZ 75kHz		
2141	4822 126 13838	100nF	10% 50V	5123	2422 549 44108	RF-COIL, AM-OSCILLATOR		
2143	4822 126 14076	220nF	20% 25V	5130	4822 157 11843	RF COIL 1,5 TURNS		
2144	4822 124 21913	1μF	20% 63V					
				5131	4822 157 11843	RF COIL 1,5 TURNS		
2145	4822 122 33575	220pF	5% 50V	DIODES				
2146	4822 122 33575	220pF	5% 50V	6103	5322 130 34337	BAV99		
2147	4822 122 33575	220pF	5% 50V	6105	4822 130 83075	HN1V02H		
2148	4822 122 33127	2,2nF	10% 63V	6106	4822 130 83757	BAS216		
2149	5322 122 32659	33pF	5% 50V	6107	9340 386 90115	BZX284-C11		
			RDS only	6120	4822 130 83757	BAS216		
2150	4822 126 13838	100nF	10% 50V	6130	4822 130 82833	1SV228		
2152	4822 126 12105	33nF	5% 63V	6131	4822 130 82833	1SV228		
2152	5322 116 80853	560pF	5% 63V					
2153	4822 126 13486	15pF	2% 63V	TRANSISTORS				
2153	4822 122 33926	12pF	2% 50V	7102	4822 130 42131	BF550		
			not for East Europe only	7103	5322 130 42756	BC857C		RDS only
2155	2020 800 00191	3-11pF TRIMCAP, N450		7111	5322 130 42755	BC847C		
2159	5322 122 32659	33pF	5% 50V	7112	4822 130 44503	BC547C		
2164	4822 126 13482	470nF	20% 16V	INTEGRATED CIRCUITS				
2165	4822 126 13838	100nF	10% 50V	7101	9351 740 80557	TEA5757H/V1, RADIO IC		
2166	5322 122 31647	1nF	10% 63V					
				3101	4822 051 20333	33kΩ	5% 0,1W	
2167	4822 122 33926	12pF	5% 50V	3102	4822 117 10837	100kΩ	1% 0,1W	
2169	4822 122 33127	2,2nF	10% 63V	3103	4822 051 20822	8,2kΩ	5% 0,1W	
			RDS only	3104	4822 117 13577	330Ω	1% 0,1W	
RESISTORS				3105	4822 117 11503	220Ω	5% 0,1W	
3101	4822 051 20333	33kΩ	5% 0,1W	3132	4822 051 20479	47Ω	5% 0,1W	
3102	4822 117 10837	100kΩ	1% 0,1W	3134	4822 051 20223	22kΩ	5% 0,1W	
3103	4822 051 20822	8,2kΩ	5% 0,1W	3141	4822 117 11148	56kΩ	1% 0,1W	
3104	4822 117 13577	330Ω	1% 0,1W	3142	4822 100 12159	TRIMPOT, 100kΩ		
3105	4822 117 11503	220Ω	5% 0,1W					

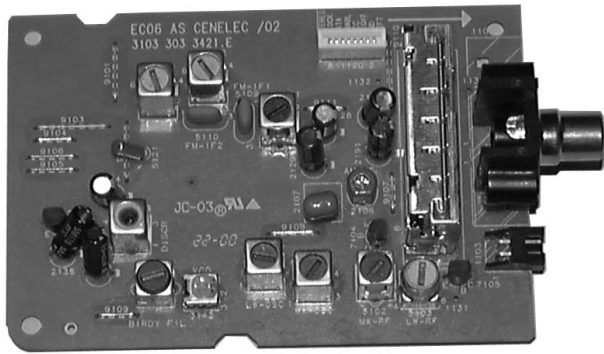

# ECO6 Tuner Board

version: **SYSTEMS CENELEC**

## TABLE OF CONTENTS

Blockdiagram .....7B-1  
 Schematic Diagram .....7B-2  
 Component Layout .....7B-3  
 Adjustment table .....7B-3  
 Electrical Partlist .....7B-4

## BLOCK DIAGRAM

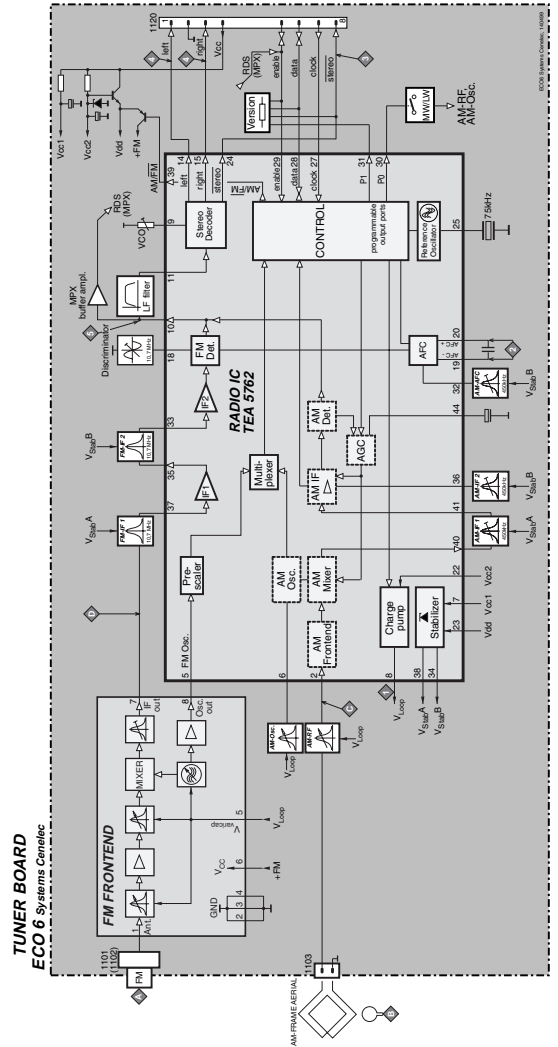

TUNER BOARD ECO6 / SYSTEMS-CENELEC

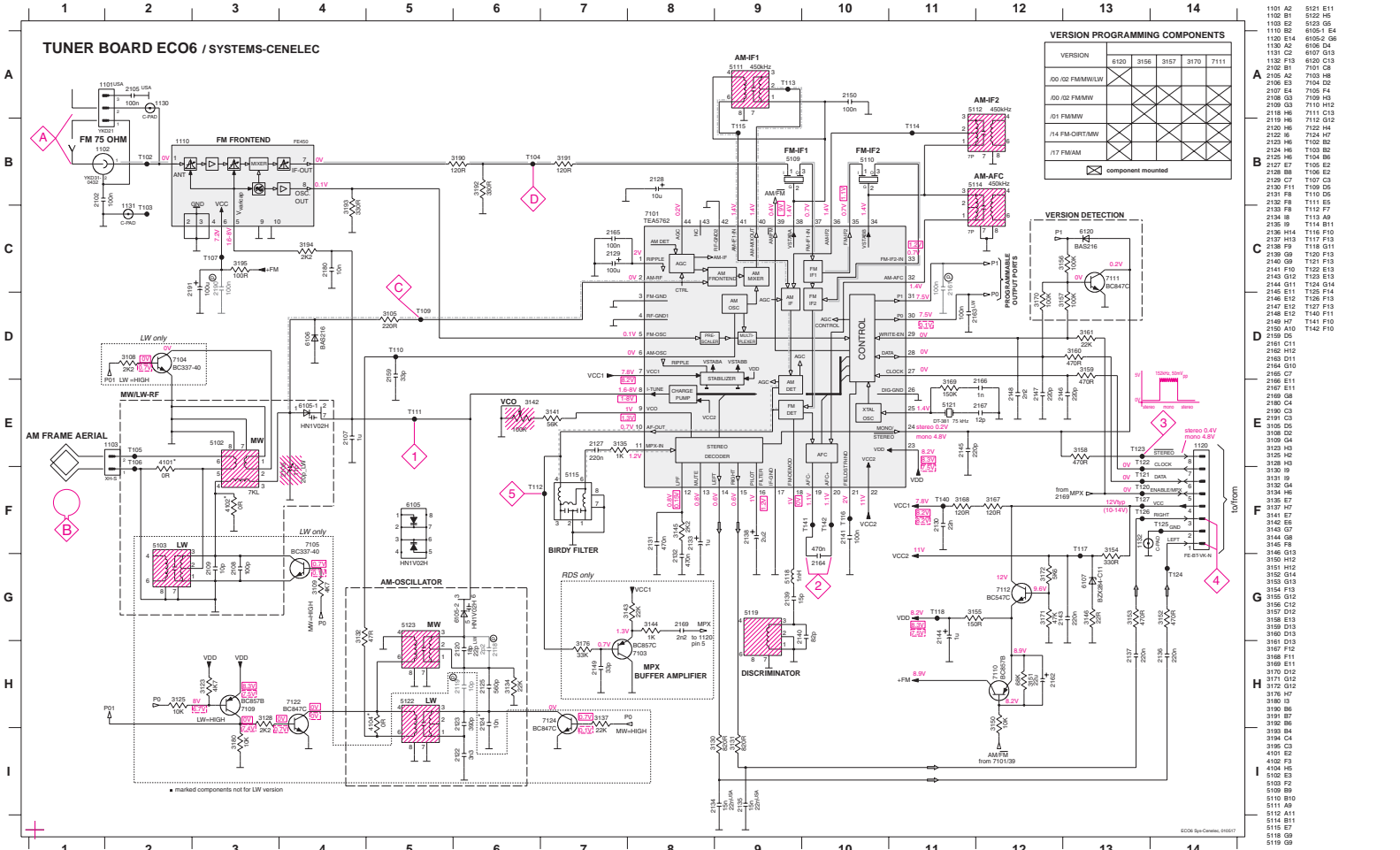

**VERSION PROGRAMMING COMPONENTS**

VERSION	6120	3156	3157	3170	7111
00/02 FM/MW/LW					
00/02 FM/MW					
01 FM/MW					
1/4 FM/ORTAM					
1/7 FM/AM					

☒ component mounted

**VERSION DETECTION**

VERSION	6120	3156	3157	3170	7111
00/02 FM/MW/LW					
00/02 FM/MW					
01 FM/MW					
1/4 FM/ORTAM					
1/7 FM/AM					

- 1101 A2
- 1102 B1
- 1103 B4
- 1110 B2
- 1131 C1
- 1132 F13
- 1133 B1
- 2105 A2
- 2106 E3
- 2107 E4
- 2108 G3
- 2109 G3
- 2120 H6
- 2121 H6
- 2122 H4
- 2123 H6
- 2124 H7
- 2125 H6
- 2126 H7
- 2127 H7
- 2128 B8
- 2129 C7
- 2130 F11
- 2131 F9
- 2132 F8
- 2133 F8
- 2134 B
- 2135
- 2136 H14
- 2137 H13
- 2138 F9
- 2139 G9
- 2140 G9
- 2141 F10
- 2142 H11
- 2143 E12
- 2144 G11
- 2145 H11
- 2146 E12
- 2147 E12
- 2148 E12
- 2149 F10
- 2150 A10
- 2151 C11
- 2152 C7
- 2153 H11
- 2154 B11
- 2155 B11
- 2156 H11
- 2157 H11
- 2158 C4
- 2159 C3
- 2160 C3
- 2161 C3
- 2162 C3
- 2163 C3
- 2164 C3
- 2165 C3
- 2166 C3
- 2167 C3
- 2168 C3
- 2169 C3
- 2170 C3
- 2171 C3
- 2172 C3
- 2173 C3
- 2174 C3
- 2175 C3
- 2176 C3
- 2177 C3
- 2178 C3
- 2179 C3
- 2180 C3
- 2181 C3
- 2182 C3
- 2183 C3
- 2184 C3
- 2185 C3
- 2186 C3
- 2187 C3
- 2188 C3
- 2189 C3
- 2190 C3
- 2191 C3
- 2192 C3
- 2193 C3
- 2194 C3
- 2195 C3
- 2196 C3
- 2197 C3
- 2198 C3
- 2199 C3
- 2200 C3

**LEGEND**

- ... only assembled in FM/AM version
- ⊙ ... for precision only
- USA ... for USA version only
- LW ... for LW version only
- SMD jumper
- FM mode stereo
- MW mode
- LW mode
- voltages measured while set is tuned to a strong transmitter
- Signal path
- FM
- AM
- MPX (Audio Frequency)
- AP - left/right

©2004 RayCircuit, 090017

1101 B5 1110 B4 1131 C5 2107 B3 2133 C1 2162 A4 5102 C4 5110 A2 5114 A2 5121 B2 7104 C4 9101 A2 9104 B1 9107 B4 9110 A4  
 1102 B5 1120 A4 1132 A4 2128 A3 2138 B1 2191 B4 5103 C4 5111 A3 5115 C2 5122 C3 7105 C5 9102 B2 9105 B1 9108 B3 9111 A3  
 1103 C5 1130 A5 2106 B4 2129 B3 2144 B1 3142 C2 5109 B3 5112 A2 5119 B2 5123 C3 7112 B1 9103 A1 9106 B1 9109 C2

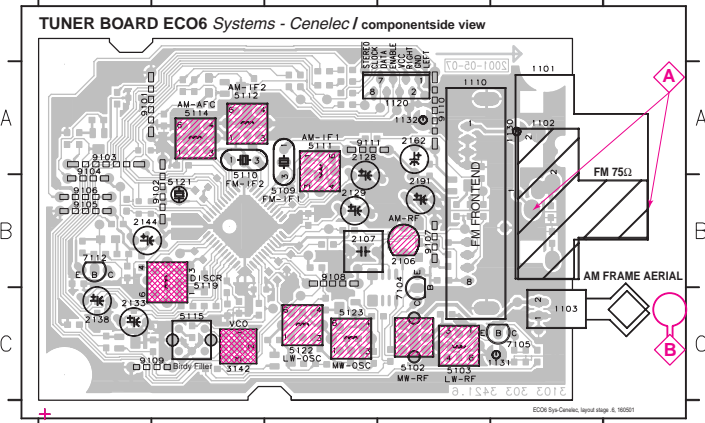

2102 B1 2120 C3 2130 B3 2137 A3 2146 B5 2161 A4 2169 A3 3123 A5 3134 C3 3145 C4 3154 B5 3160 A3 3171 B5 3182 A2 4104 C3 6106 B2 7110 B2  
 2106 B1 2122 C3 2131 C4 2139 B4 2147 A5 2163 A4 2180 B2 3125 A5 3135 C4 3146 B5 3155 B5 3161 A4 3172 B5 3183 B2 4105 B2 6107 B5 7111 A4  
 2108 C1 2123 C3 2132 C4 2140 B4 2148 B4 2164 B4 2190 B2 3128 C2 3137 C4 3150 B3 3156 A4 3167 A5 3176 C4 3194 B2 4106 B3 6120 A4 7122 C3  
 2109 C1 2124 C3 2134 C5 2141 B5 2149 C4 2165 B3 3105 B3 3130 C4 3141 B3 3151 A2 3157 A4 3168 C5 3180 A5 3185 B2 4107 C4 7101 B4 7124 C3  
 2118 C3 2125 C3 2135 C5 2143 B5 2159 B3 2166 B5 3109 C2 3131 C4 3143 C5 3152 A3 3158 A3 3169 B4 3180 B2 4101 C2 5118 C4 7103 C5  
 2119 C3 2127 C4 2136 A3 2145 B5 2159 B3 2167 B4 3109 C1 3132 B3 3144 A5 3153 A3 3159 A3 3170 A4 3191 A3 4102 C2 6105 B2 7109 A5

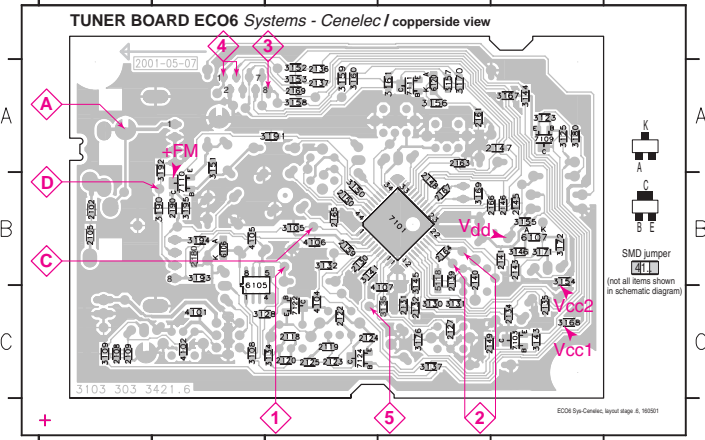

These assembly drawings show a summary of all possible versions.  
 For components used in a specific version see schematic diagram respectively partlist.

**TUNER ADJUSTMENT TABLE ( ECO6 Cenelec FM/MW - and FM/MW/LW - versions with AM-frame aerial )**

Waverange	Input frequency	Input	Tuned to	Adjust	Output	Scope/Voltmeter
<b>VARICAP ALIGNMENT</b>						
FM 87.5 - 108MHz (50kHz grid)			108MHz	check		8V ±1.2V
			87.5MHz	check		1.6V ±0.5V
MW 531 - 1602kHz (9kHz grid)			1602kHz	5123	1	8V ±0.2V 3-band 6.9V ±0.2V 2-band
			531kHz	check		1.1V ±0.4V
LW 153 - 279kHz (3kHz grid)			279kHz	5122		8V ±0.2V
			153kHz	check		1.1V ±0.4V
<b>FM - IF</b>						
FM	10.7MHz, 45mV continuous wave	D		5119	2	0mV ±3mV
<b>FM - VCO</b>						
FM	98MHz, 1mV continuous wave	A	98MHz	3142	3	152kHz ±1kHz <sup>1)</sup>
<b>FM RF (channel separation)</b> Note: The FM-frontend unit has already been adjusted by the factory and needs therefore no further adjustments for service purposes.						
FM	98MHz, 1mV 90% Left + 9% pilot mod=1kHz	A	98MHz	IF coil inside FM frontend 1110	4	right channel min.
<b>AM IF</b>						
MW	450kHz connect pin 6 of IC 7101 (AM Osc.) with 3.3kΩ to Vcc	C	$\Delta f = \pm 10\text{kHz}$ $V_{RF} = 0.5\text{mV}$ (as low as possible)	 5111 5112	5	
AM AFC MW		C	continuous wave $V_{RF} = 2\text{mV}$	5114	2	0mV ±2mV
<b>AM RF<sup>3)</sup></b>						
MW	1494kHz	B	1494kHz	2106	5	
	558kHz		558kHz	5102		
LW	198kHz		$\Delta f = \pm 30\text{kHz}$ $V_{RF}$ as low as possible	198kHz	5103	

Use Service Testprogram. By selecting the TUNER TEST test frequencies will be stored as preset frequencies automatically.  
<sup>1)</sup> If sensitivity of frequency counter is too low adjust to max. channel separation (input signal: stereo left 90% + 9%, adjust output on right channel to minimum)  
<sup>2)</sup> RC network serves for damping the IF-filter while adjusting the other one.  
<sup>3)</sup> For AM RF adjustments the original frame antenna has to be used!  
 MW has to be aligned before LW.  
 ↑ Repeat





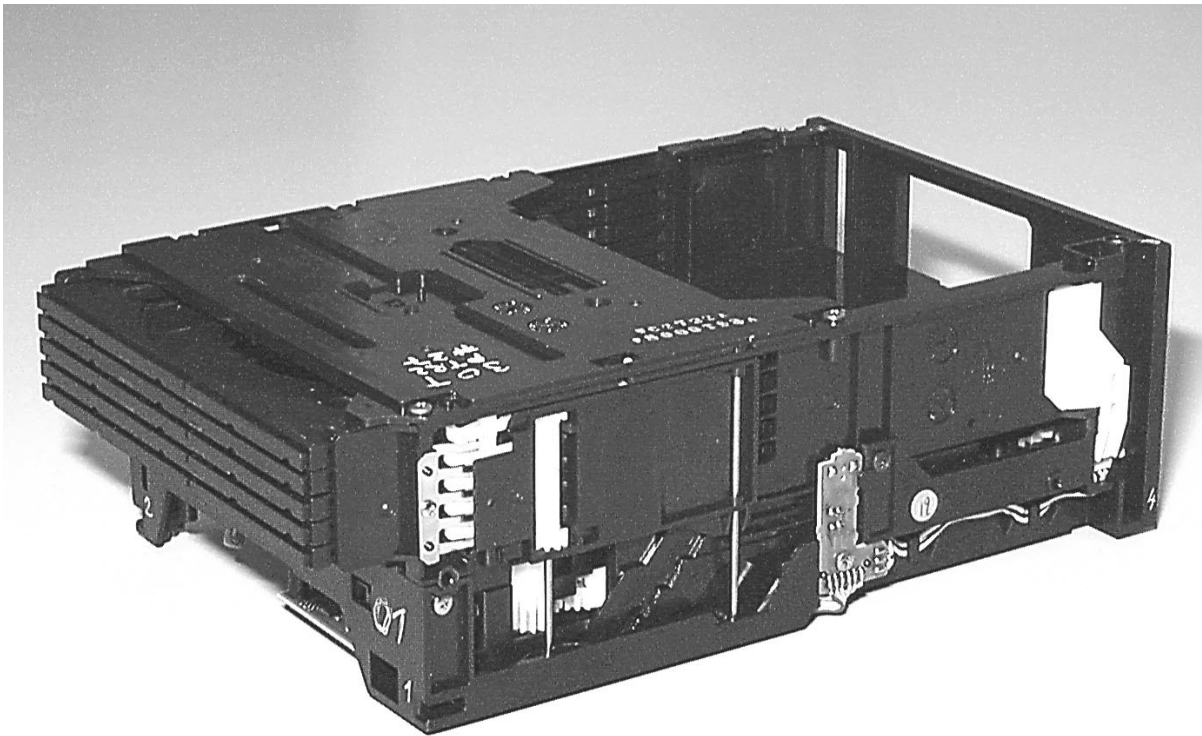

# **5DTC Module**

## **(MP3 version)**

Layout stage .4

### TABLE OF CONTENTS

Service hints .....	10-2
Location of Printed Circuit Boards .....	10-5
Wiring .....	10-6
Emergency opening .....	10-7
Location of switches .....	10-8
Blockdiagram .....	10-9
<b>CD BOARD</b>	
Circuit Diagram .....	10-10
Component Layout side A .....	10-11
Component Layout side B .....	10-12
<b>CONTROL BOARD</b>	
Circuit Diagram .....	10-13
Component Layout .....	10-13
<b>MP3 BOARD</b>	
Circuit Diagram .....	10-14
Component Layout .....	10-15
Exploded view loader .....	10-16
Partslist .....	10-17

# Service Hints

In case of symptom „skipping tracks“ perform following actions:

## 1. VERIFY THE COMPLAINT

### PLAYABILITY CHECK

- Use CDDA SBC 444A: . . . . . 4822 397 30245
  - TR 14 (600µ black dot) maximum at 01:15
  - TR 19 (fingerprint)
  - TR 10 (1000µ wedge)

- Use CD-RW Printed Audio Disk . . . . . 7104 099 96611
  - TR 3 (Fingerprint)
  - TR 8 (600µ black dot) maximum at 01:00

- playback of all these tracks without audible disturbance
- jump forward/backward within a reasonable time

## 2. CLEAN THE LENS

### CD DRIVE – LENS CLEANING

Before touching the lens it is advised to clean the surface of the lens by blowing clean air over it in order to avoid that little particles make scratches on the lens.

Because the material of the lens is synthetic and coated with a special anti-reflectivity layer, cleaning must be done with a non-aggressive cleaning fluid. It is advised to use "KODAK LENS CLEANER CAT 176 71 36", available in normal photo shops.

The actuator is a very precise mechanical component and may not be damaged in order to guarantee its full function. It is advised to clean the lens gently (don't press too hard) with a soft and clean cotton bud moistened with the special lens cleaner.

The direction of cleaning must be in the way as indicated in the picture below.

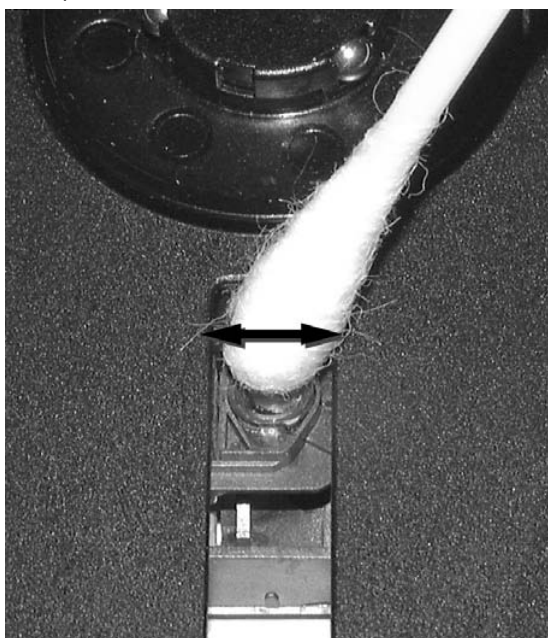

## 3. MEASURE THE EYE-PATTERN SIGNAL

### EYE-PATTERN SIGNAL – JITTER MEASUREMENT

Measure the signal direct on resistor 3898 using an oscilloscope (see also chapter 10-9).

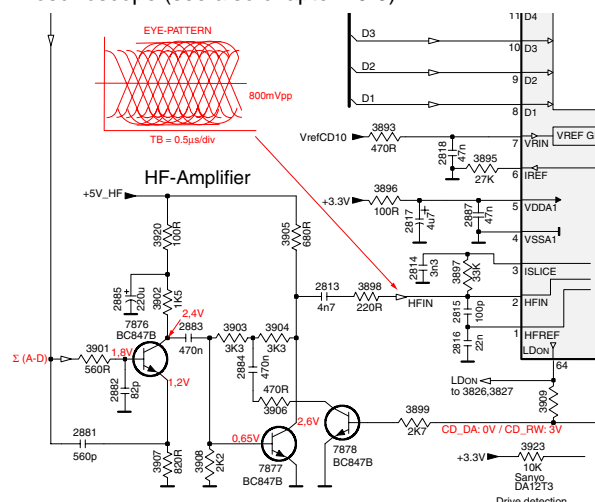

See below examples of the signal. Amplitude should read at least 700mVpp using SBC444A.

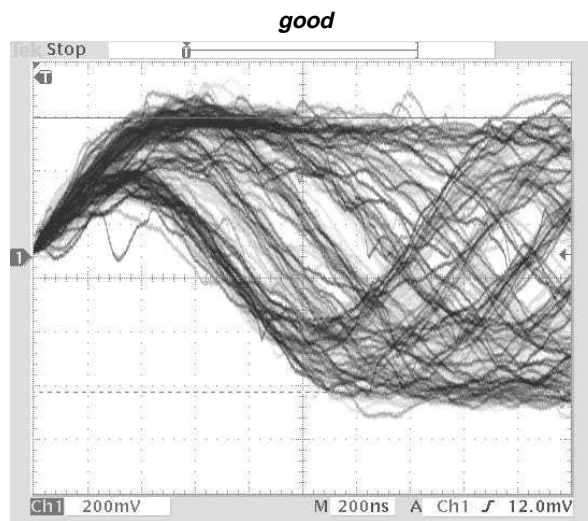
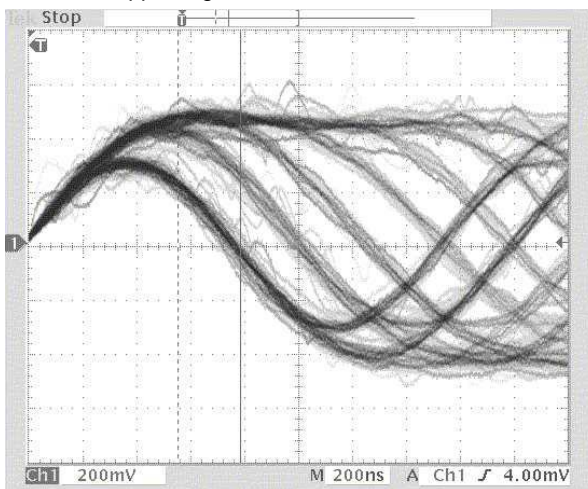

If the oscilloscope shows a signal like the 'bad' one, and/or the amplitude decreases within 1minute - the CD drive has to be replaced.

## Service Hints

### 4. MEASURE THE LASER CURRENT

#### CD DRIVE – LASER CURRENT MEASUREMENT

The laser current can be measured as a voltage drop on resistor 3820. Typical value 170 - 190mV for CD-DA respectively 200 - 220mV for CD-RW.

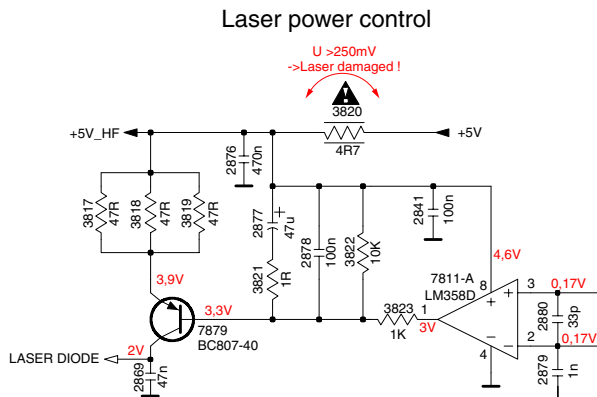

### 5. MEASURE THE OFFSETS OF THE CD-DRIVE

#### CD DRIVE – OFFSET MEASUREMENT

Each photodiode of the CD-drive may have an offset. This offset has to be compensated by the signal processor. A high offset of the CD-drive leads to poor playability of some CDs (skipping tracks).

Start the **Service Test Program** - section „Focus Test“ without a CD. Focus sensitivity = CD-RW.

Use a DC Millivoltmeter for measurement. The offsets can be measured direct on the connector. See drawing below.

The values from diode A-D should read  $0 \pm 10\text{mV}$ . Diodes E and F are less critical.

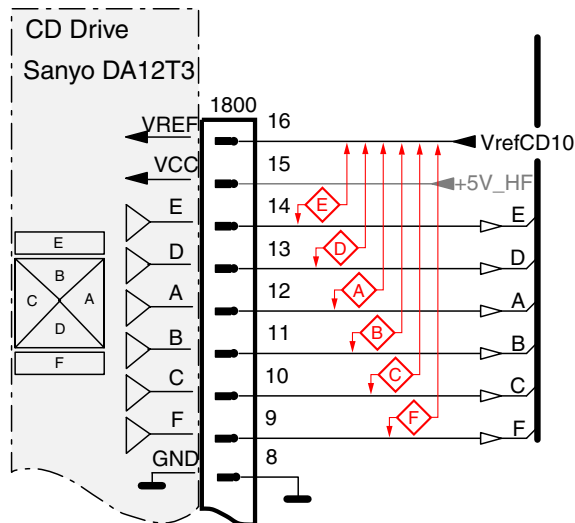

If one of the offsets is higher than  $\pm 10\text{mV}$  the CD drive has to be replaced.

### 6. MEASURE THE OFFSETS OF THE CD10

#### SIGNAL PROCESSOR – OFFSET MEASUREMENT

Each ADC input of the CD10 may have an offset too. Also this offset leads (together with the offsets of the CD Drive) to poor playability of some CDs (skipping tracks).

Start the **Service Test Program** - section „Focus Test“ using a CD-RW disc.

Use a DC Millivoltmeter for measurement. The offsets can be measured on capacitors near the signal processor. See drawing below.

The value should read  $0\text{mV} \pm 10\text{mV}$ .

#### CD Board side A view

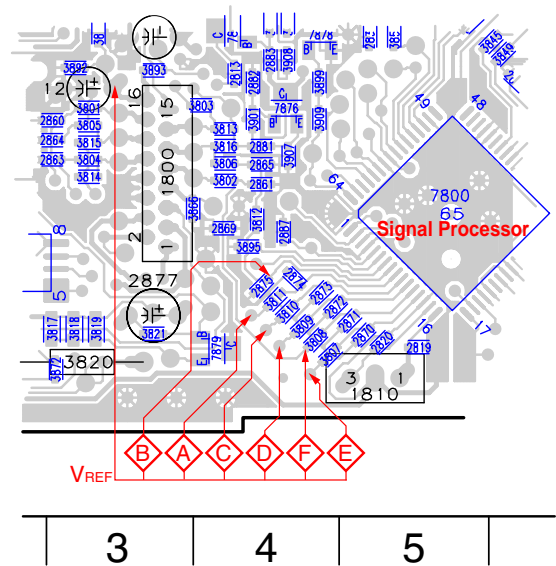

If one of the offsets is higher than  $\pm 10\text{mV}$  the signal processor has to be replaced.

If none of the measured offsets is higher than  $\pm 10\text{mV}$  - replace the part with the higher value.

**WARNING**

**CHARGED CAPACITORS ON THE SERVO BOARD MAY DAMAGE THE CD DRIVE ELECTRONICS WHEN CONNECTING A NEW CDM MECHANISM. THAT'S WHY, BESIDES THE SAFETY MEASURES LIKE**

- **SWITCH OFF POWER SUPPLY**
- **ESD PROTECTION**

**ADDITIONAL ACTIONS MUST BE TAKEN BY THE REPAIR TECHNICIAN.**

The CD drive forms a compact building block with the CD Board.

The following steps have to be done when replacing the CD mechanism:

1. Desolder disc and slide motor
2. Loosen 2x screw
  1. Disconnect flexfoil from old CD drive
  2. Put a paperclip over contacts of flexfoil to short-circuit the contacts (fig.1)
  3. Remove old CD drive
  4. Mount new CD drive to CD board
  5. Solder disc and slide motor **after** fixing the drive to the board
  5. Move slide outside
  6. Remove paperclip from flexfoil
  7. Connect flexfoil to new CD drive
  8. Remove ESD-protection (solder joint) from laserunit (see picture below)

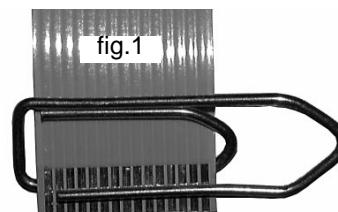

**Attention:** The laser diode of this CD drive is protected against ESD by a solder joint which shortcircuits the laserdiode to ground. For proper functionality of the CD drive this solder joint must be removed **after** connection the drive to the set.

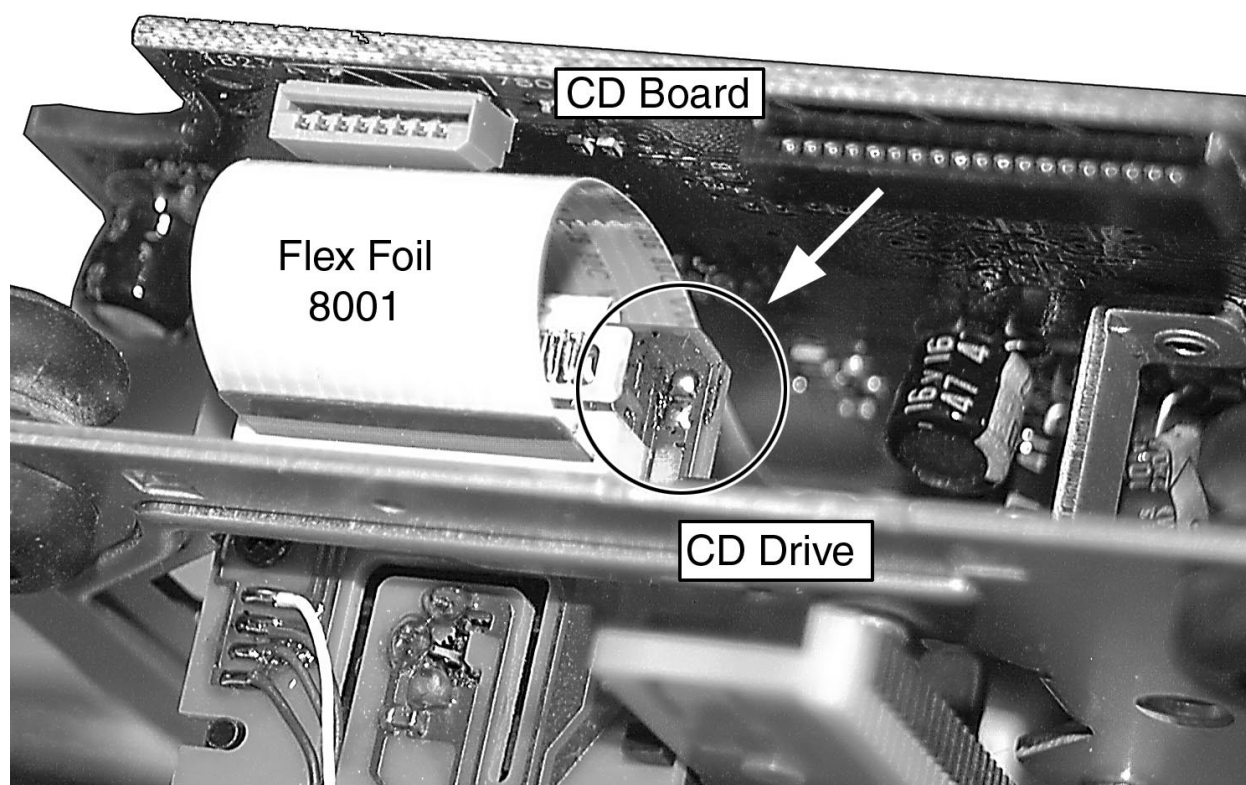

# Location of Printed Circuit Boards

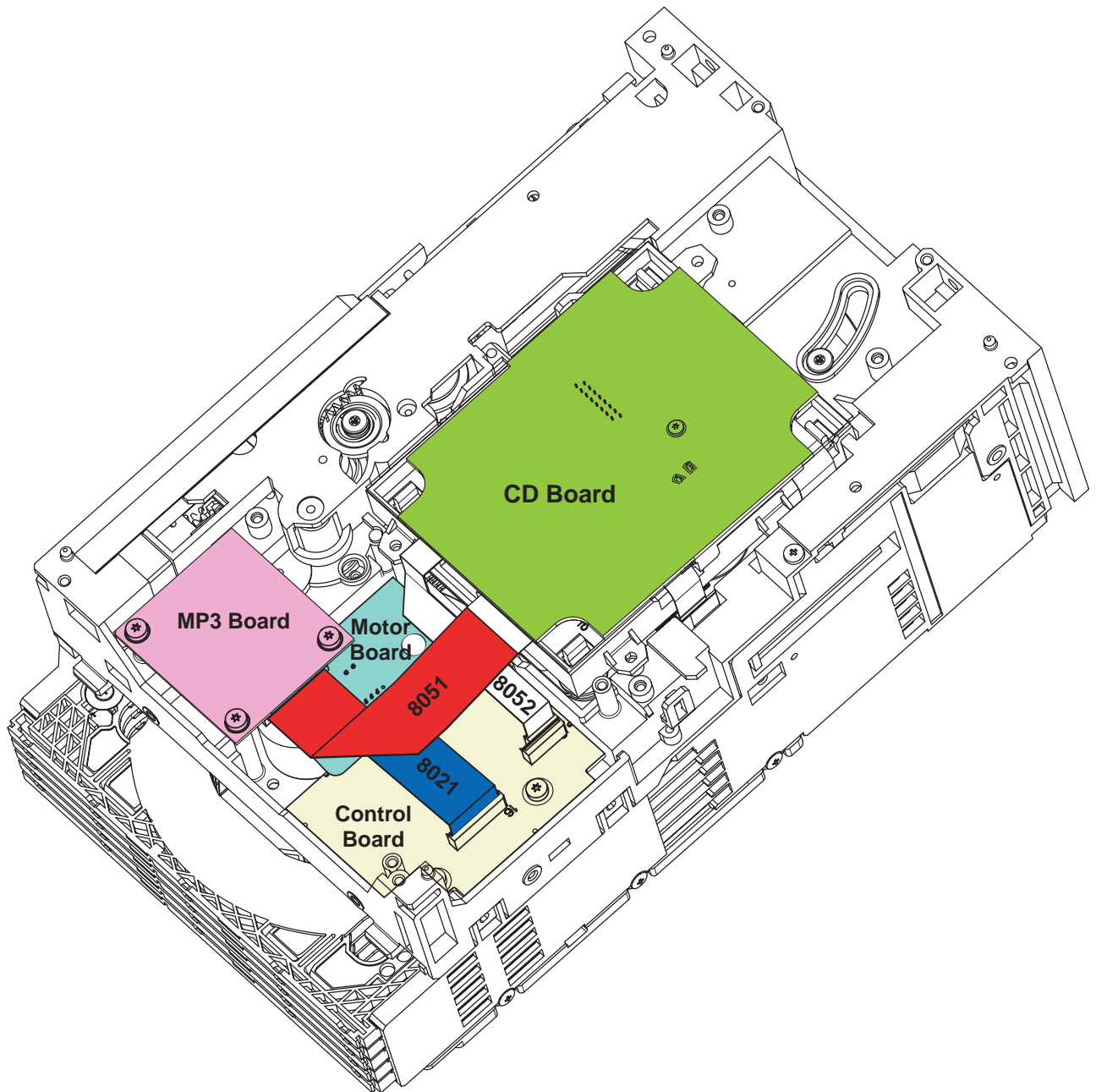

SDTC Location of PCBs 2002 08 29

## Wiring Diagram 5DTC Module

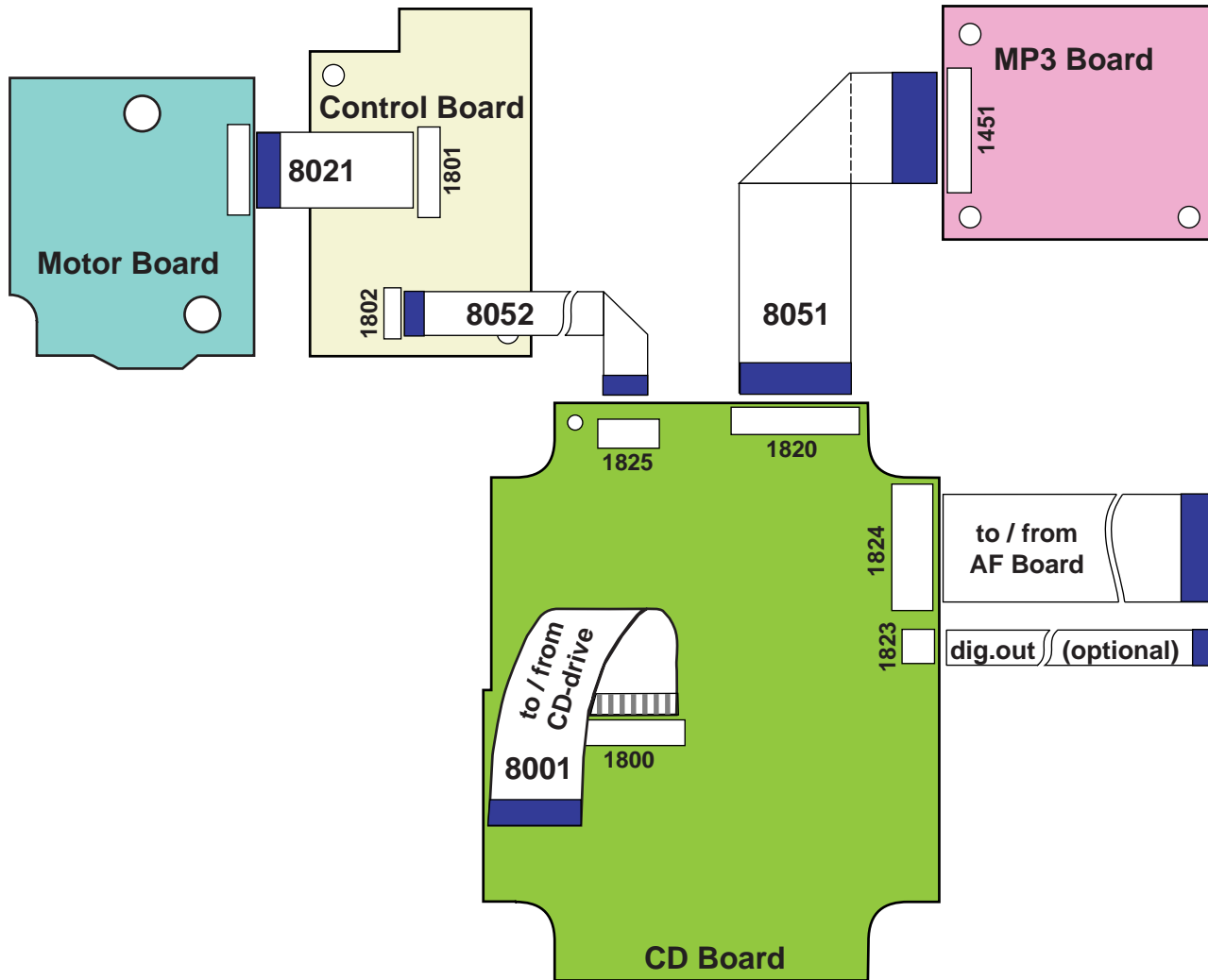

5DTC Wiring Diagram 2002 08 30

The FFC-Cables are available as sparepart.

8001	3103 308 93090	FFC CABLE 16Pin 80mm BD	Connection from CD Board to CD Drive
8051	3103 308 93100	FFC-CABLE 19Pin 90mm AD	Connection from CD Board to MP3 Board
8052	3103 308 93120	FFC CABLE 8Pin 80mm BD	Connection from CD Board to Control Board
8021	3103 308 93110	FFC-CABLE 16Pin 60mm AD	Connection from Control Board to Motor Board

## Emergency opening of the trays

The trays of the 5DTC are mechanically locked.

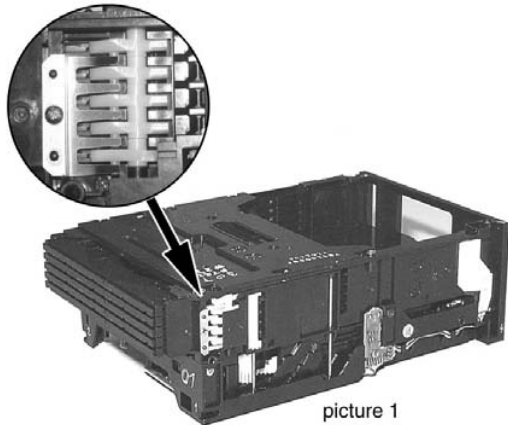

picture 1

To open tray 1, 2 and 3 move lever (pos 29) backwards (e.g. with a screwdriver - see picture 2) to its endposition.

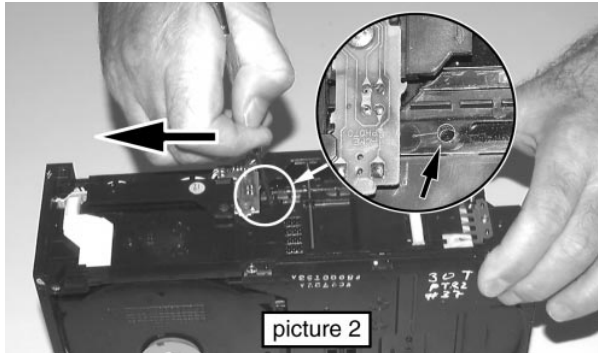

picture 2

Release the locking mechanism and pull out the tray (see picture 3).

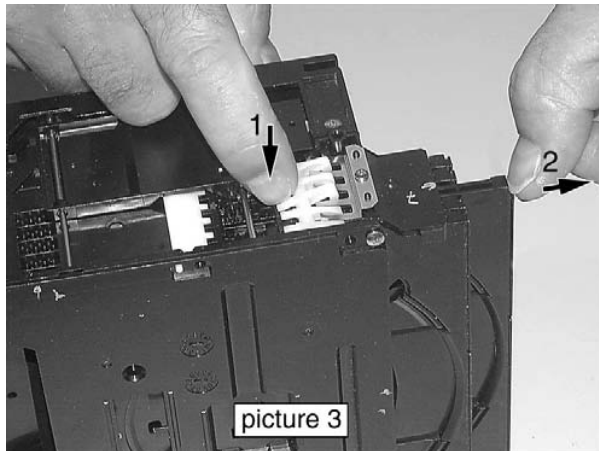

picture 3

To open tray 4 and 5 move lever (pos 29) forward to its endposition (see picture 4).

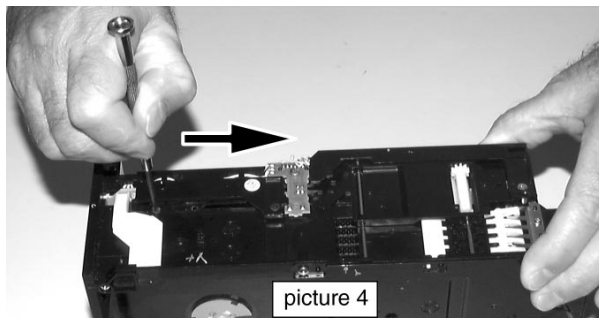

picture 4

Release snap as shown in picture 5 and pull tray out.

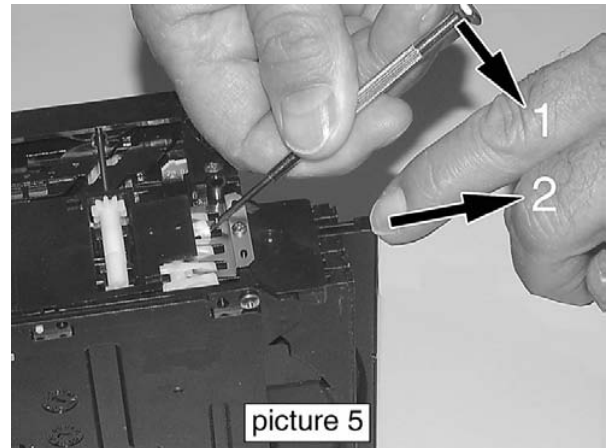

picture 5

To remove a CD from Play Position perform following steps:

1. Open tray 1 as described before.
2. Tear the tray out with speed (see picture 6). The tray can be inserted afterwards without any alignment.

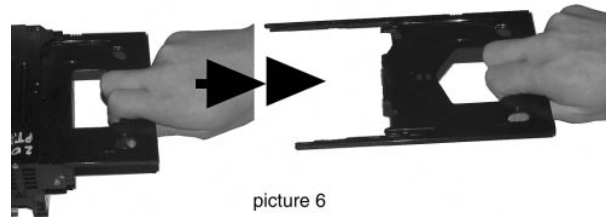

picture 6

3. Move lever (pos 29) forward to its endposition (see picture 4).
4. Push lever (pos 31) forward (see picture 7).

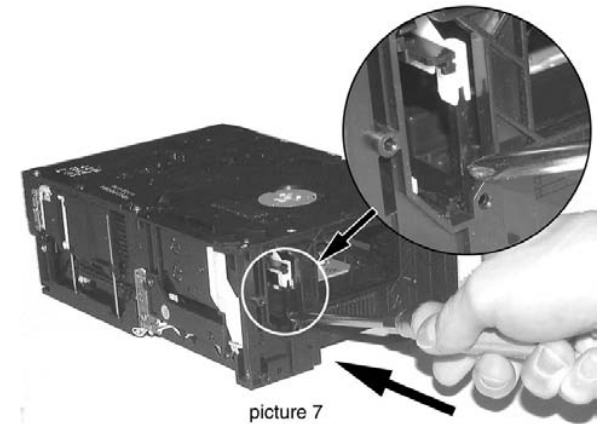

picture 7

5. Remove CD.

### Location of switches

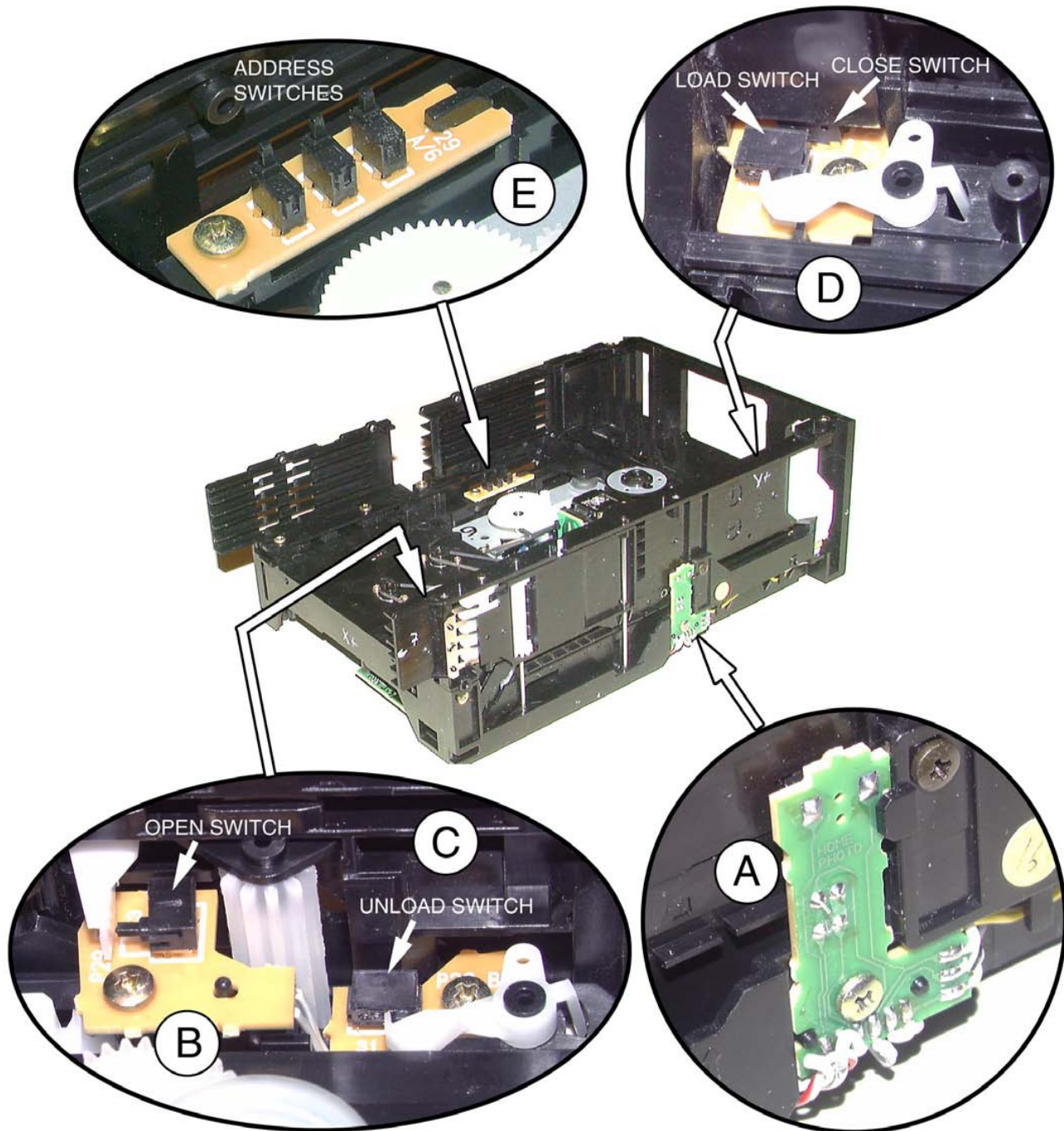



### BLOCK DIAGRAM 5DTC MP3 Version

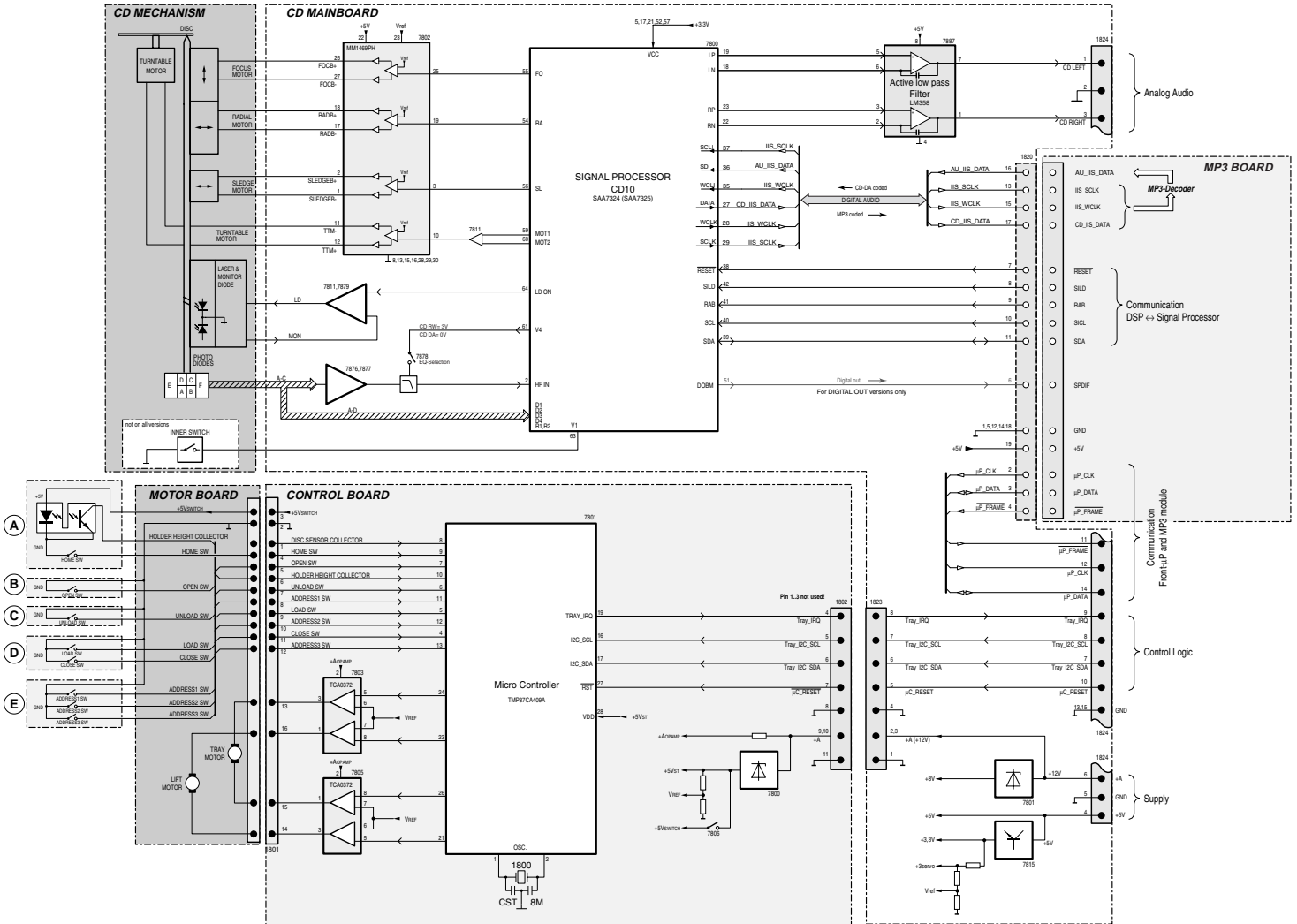

5DTC CD BOARD

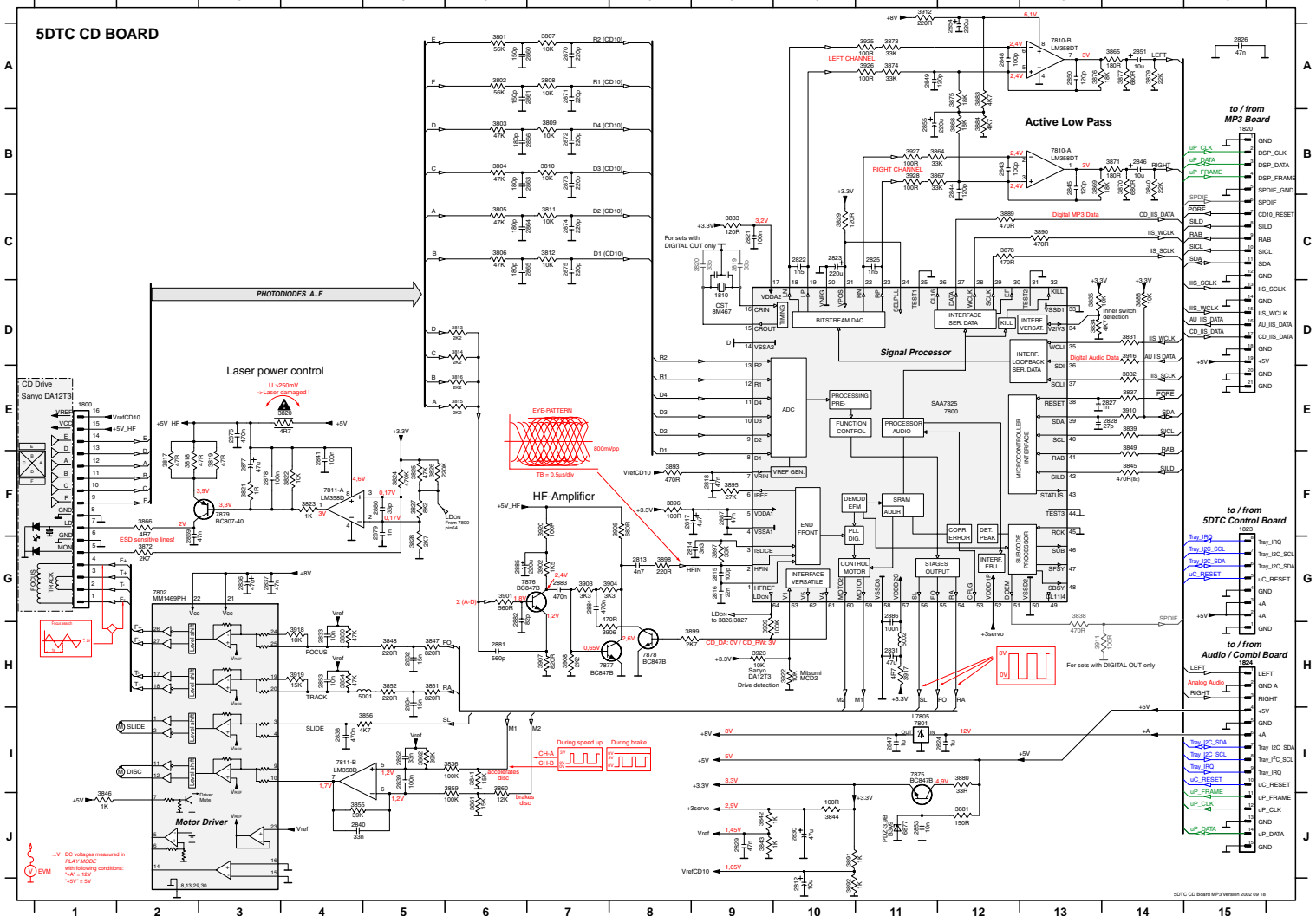

5DTC CD Board MP3 Version 2002.09.10

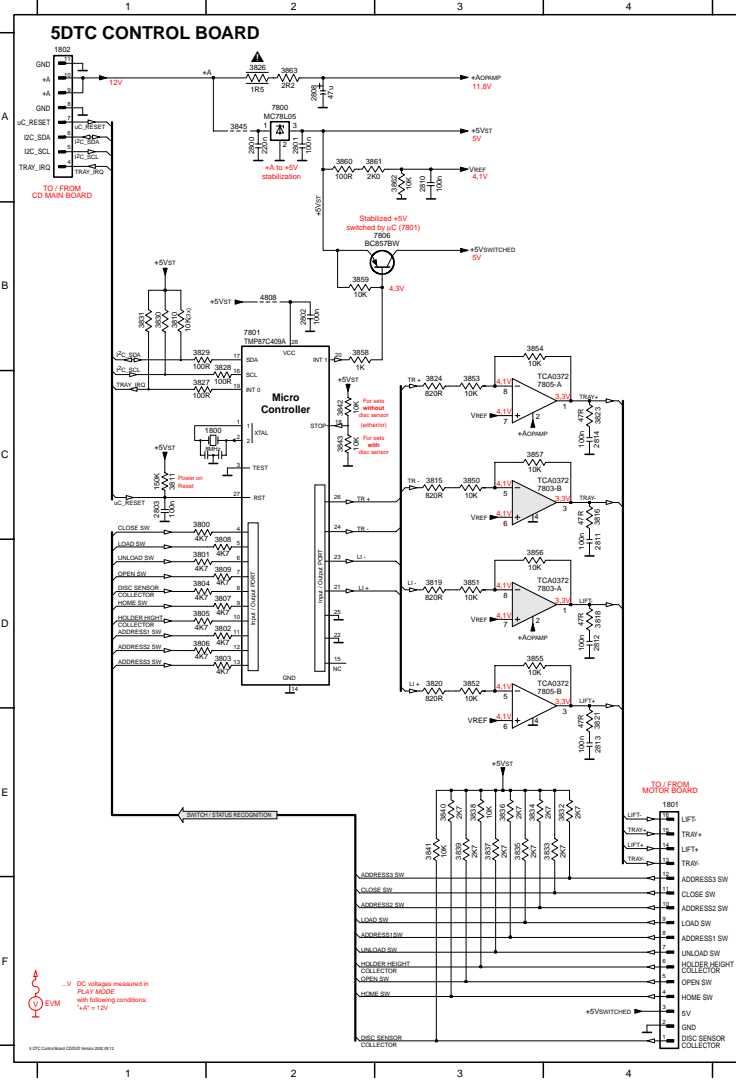

MAPPING FOR CIRCUIT DIAGRAM

1800	C2	2810	A3	3804	D1	3811	C1	3824	C3	3833	E4	3841	E3	3854	B3	3862	A3	7805-B	D3
1801	E4	2811	D4	3805	D1	3815	C3	3826	A2	3834	E2	3842	C2	3855	D3	3863	A2	7805-B	B3
1802	A1	2812	D4	3806	D1	3816	C4	3827	C1	3835	E3	3843	C2	3856	D3	3864	B2	7805-B	D3
2800	A2	2813	E4	3807	D2	3818	D4	3828	C2	3836	E3	3845	A2	3857	C3	3865	A2	7805-B	B3
2801	A2	2814	C4	3808	D1	3819	D3	3829	B1	3837	E3	3850	C3	3858	B2	3866	A2	7805-B	B3
2802	B2	3800	C1	3808	D2	3820	D3	3830	B1	3838	E3	3851	D3	3859	B3	3867	A2	7805-B	C3
2803	C1	3802	D2	3809	D2	3821	E4	3831	B1	3839	E3	3852	D3	3860	A2	3868	A2	7805-B	C3
2808	A2	3803	D2	3810	B1	3823	C4	3832	E4	3840	E3	3853	C3	3861	A2	3869	A2	7805-B	C3

MAPPING FOR COMPONENT LAYOUT

1800	B2	2810	A5	3806	C4	3819	A4	3832	C4	3843	A2	3857	A5	4804	A2	4816	D2	7803	A5
1801	C4	2811	A5	3807	C3	3820	A4	3833	B2	3845	D2	3858	B5	4805	C1	4817	A5	7803	B2
1802	C2	2812	A6	3808	B2	3821	B5	3834	C4	3847	B1	3859	C5	4806	A2	4818	C5	7803	C5
2800	D2	2813	B5	3809	C3	3823	B6	3835	C2	3848	B1	3860	C5	4807	C1	4819	A6	7803	C5
2801	D2	2814	B6	3810	C2	3824	A4	3836	C4	3850	A4	3861	B5	4808	C2	4820	B5	7803	B2
2802	A2	3800	B2	3811	A2	3826	B6	3837	C3	3851	A4	3862	A5	4809	C5	4821	C3	7803	A5
2803	B1	3801	C3	3812	A1	3827	B2	3838	C4	3852	A4	3863	B6	4810	B2	4822	C3	7803	B2
2804	C2	3802	C4	3813	B2	3828	C2	3839	C3	3853	A4	4800	C2	4811	C1	4823	B1	7803	B2
2805	C1	3803	C4	3815	A4	3829	B2	3840	C4	3854	B5	4801	C2	4812	B2	4824	D2	7803	D2
2806	A6	3804	C3	3816	A5	3830	C2	3841	C3	3855	B5	4802	C2	4813	B6	4825	B4	7803	B4
2808	C2	3805	C4	3818	A6	3831	C1	3842	A2	3856	A6	4803	D1	4814	A4	4826	A2	7803	A2

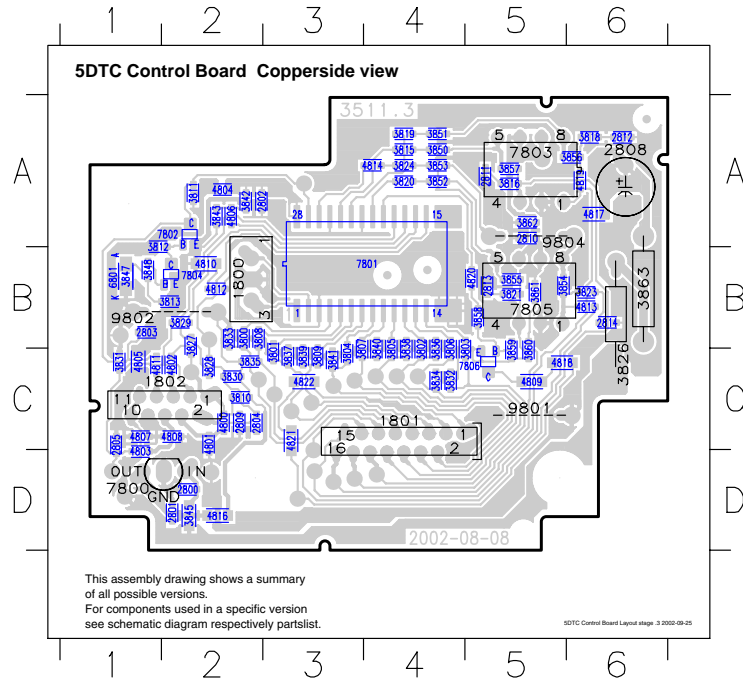

MP3 BOARD - CIRCUIT DIAGRAM

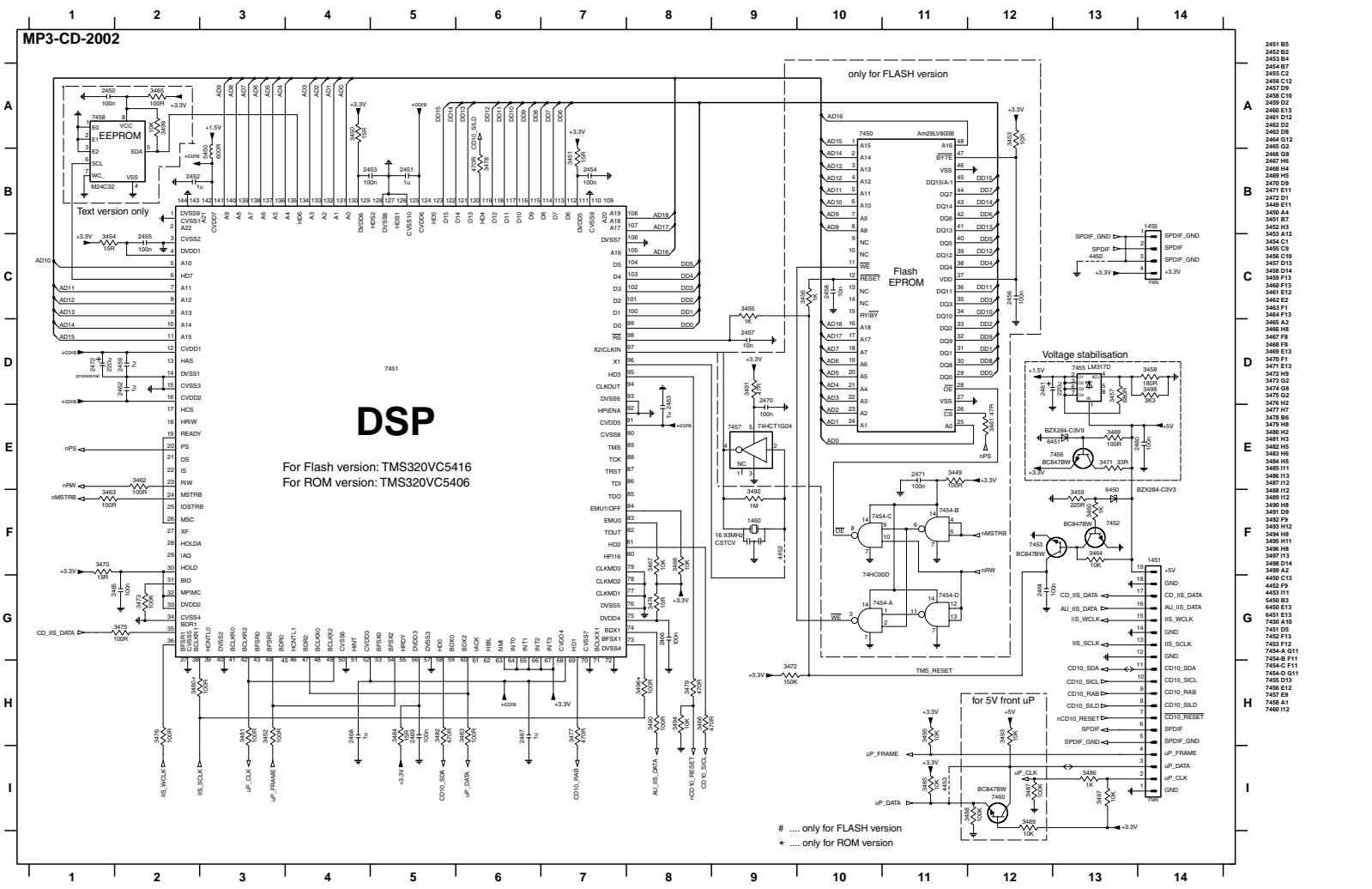

# ..... only for FLASH version  
 \* ..... only for ROM version

Exploded view 5DTC mechanic - for orientation only

Sketch-1

TRAY(SUB)	③	④②	④②	④②	④②
TRAY No.	TRAY 1	TRAY 2	TRAY 3	TRAY 4	TRAY 5
Part A	①	HOLE	①	HOLE	①
Part B	②	②	HOLE	HOLE	②
Part C	③	③	③	③	HOLE

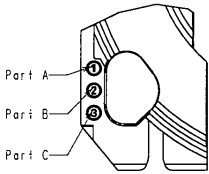

Sketch-2

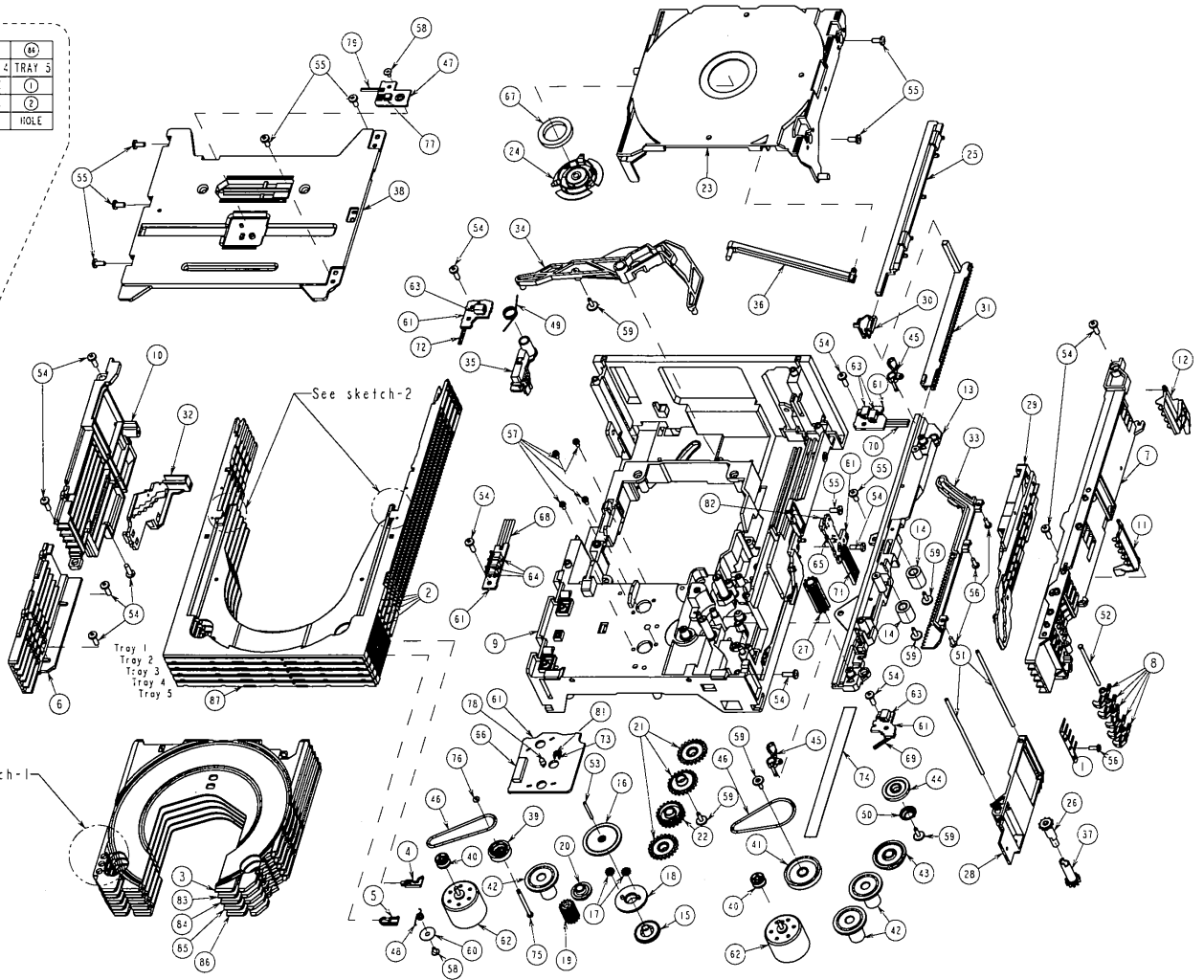
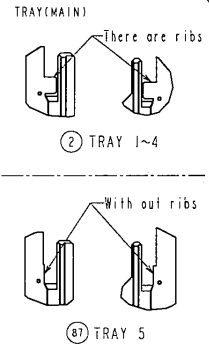

See sketch-1

See sketch-2

Tray 1  
Tray 2  
Tray 3  
Tray 4  
Tray 5

**ELECTRICAL PARTSLIST 5DTC MODULE MP3CD Version CD Board****MECHANICAL PARTS**

	<b>3103 308 54710</b>	<b>5DTC Module</b> (mechanic w/o electronic)
201	3103 309 05390	CD DRIVE DA12T3
252	4822 529 10387	Rubber damper CD DRIVE, FRONT
253	4822 529 10386	Rubber damper CD DRIVE, REAR

**MISCELLANEOUS**

	<b>3103 308 67020</b>	<b>MP3 Board</b>
1800	4822 267 11028	FFC-CONNECTOR 16P, Side entry
1820	2422 025 17303	FFC-CONNECTOR 19P, Side entry
1823	2422 025 16371	FFC-CONNECTOR 8P, Side entry
1824	4822 265 10979	FFC-CONNECTOR, 15P, Side entry
8001	3103 308 93090	FFC CABLE 16Pin 80mm BD
8051	3103 308 93100	FFC-CABLE 19Pin 90mm AD
8052	3103 308 93120	FFC CABLE 8Pin 80mm BD

**CAPACITORS**

2812	4822 124 11947	10µF	20%	16V
2813	4822 126 13193	4,7nF	10%	63V
2814	5322 126 11579	3,3nF	10%	63V
2815	2020 552 94427	100pF	5%	50V
2816	3198 017 42230	22nF	10%	50V

2817	4822 124 22726	4,7µF	20%	35V
2818	3198 024 44730	47nF	5%	50V
2821	2238 586 59812	100nF	10%	50V
2822	4822 126 13344	1,5nF	5%	63V
2823	4822 124 42383	220µF	20%	4V

2824	4822 126 14043	1µF	20%	16V
2825	4822 126 13344	1,5nF	5%	63V
2826	3198 017 34730	47nF	10%	16V
2827	5322 126 11578	1nF	10%	63V
2828	4822 126 11669	27pF	10%	50V

2829	3198 017 34730	47nF	10%	16V
2830	4822 124 81286	47µF	20%	16V
2831	4822 124 81286	47µF	20%	16V
2832	3198 017 31530	15nF	10%	50V
2833	5322 126 11583	10nF	10%	63V

2834	3198 017 31530	15nF	10%	50V
2835	5322 126 11583	10nF	10%	63V
2836	4822 124 40433	47µF	20%	25V
2837	3198 017 34730	47nF	10%	16V
2838	3198 017 44740	470nF	20%	10V

2839	2238 586 59812	100nF	10%	50V
2840	4822 126 14549	33nF	10%	16V
2841	2238 586 59812	100nF	10%	50V
2843	2020 552 94427	100pF	5%	50V
2844	5322 122 33861	120pF	5%	NPO

2845	5322 122 33861	120pF	5%	NPO
2846	4822 124 40248	10µF	20%	63V
2847	3198 017 41050	1µF	20%	10V
2848	2020 552 94427	100pF	5%	50V
2849	5322 122 33861	120pF	5%	NPO

2850	5322 122 33861	120pF	5%	NPO
2851	4822 124 40248	10µF	20%	63V
2852	4822 126 14549	33nF	10%	16V
2853	5322 126 11583	10nF	10%	63V
2854	4822 124 12245	220µF	20%	16V

2855	4822 124 11912	220µF	20%	6,3V
2860	4822 122 33753	150pF	5%	50V
2861	4822 122 33753	150pF	5%	50V
2863	4822 126 14508	180pF	5%	50V
2864	4822 126 14508	180pF	5%	50V

2865	4822 126 14508	180pF	5%	50V
2866	4822 126 14508	180pF	5%	50V

**CAPACITORS**

2869	3198 017 34730	47nF	10%	16V
2870	4822 126 13883	220pF	5%	50V
2871	4822 126 13883	220pF	5%	50V
2872	4822 126 13883	220pF	5%	50V
2873	4822 126 13883	220pF	5%	50V

2874	4822 126 13883	220pF	5%	50V
2875	4822 126 13883	220pF	5%	50V
2876	3198 017 44740	470nF	20%	10V
2877	4822 124 40433	47µF	20%	25V
2878	2238 586 59812	100nF	10%	50V

2879	5322 126 11578	1nF	10%	63V
2880	2222 867 15339	33pF	5%	50V
2881	4822 126 14249	560pF	10%	50V
2882	4822 126 14226	82pF		50V
2883	3198 017 44740	470nF	20%	10V

2884	3198 017 44740	470nF	20%	10V
2885	4822 124 40196	220µF	20%	16V
2886	2238 586 59812	100nF	10%	50V
2887	3198 017 34730	47nF	10%	16V

**RESISTORS**

3801	4822 051 30563	56kΩ	5%	0,06W
3802	4822 051 30563	56kΩ	5%	0,06W
3803	4822 117 12925	47kΩ	1%	0,06W
3804	4822 117 12925	47kΩ	1%	0,06W
3805	4822 117 12925	47kΩ	1%	0,06W

3806	4822 117 12925	47kΩ	1%	0,06W
3807	4822 051 30103	10kΩ	5%	0,06W
3808	4822 051 30103	10kΩ	5%	0,06W
3809	4822 051 30103	10kΩ	5%	0,06W
3810	4822 051 30103	10kΩ	5%	0,06W

3811	4822 051 30103	10kΩ	5%	0,06W
3812	4822 051 30103	10kΩ	5%	0,06W
3813	4822 051 30222	2,2kΩ	5%	0,06W
3814	4822 051 30222	2,2kΩ	5%	0,06W
3815	4822 051 30222	2,2kΩ	5%	0,06W

3816	4822 051 30222	2,2kΩ	5%	0,06W
3817	4822 051 30479	47Ω	5%	0,06W
3818	4822 051 30479	47Ω	5%	0,06W
3819	4822 051 30479	47Ω	5%	0,06W
3820	4822 052 10478	4,7Ω	5%	NFR25

3821	4822 117 12917	1Ω	5%	0,06W
3822	4822 051 30103	10kΩ	5%	0,06W
3823	4822 051 30102	1kΩ	5%	0,06W
3824	4822 051 30474	470kΩ	5%	0,06W
3825	5322 117 13029	47kΩ	1%	0,06W

3826	4822 117 12891	220kΩ	1%	0,06W
3827	5322 117 13056	8,2kΩ	1%	0,06W
3828	5322 117 13052	2,7kΩ	1%	0,06W
3829	4822 051 30121	120Ω	5%	0,06W
3831	4822 051 30471	470Ω	5%	0,06W

3832	4822 051 30471	470Ω	5%	0,06W
3833	4822 051 30121	120Ω	5%	0,06W
3834	4822 051 30472	4,7kΩ	5%	0,06W
3836	4822 117 13632	100kΩ	1%	0,06W
3837	4822 051 30471	470Ω	5%	0,06W

3839	4822 051 30471	470Ω	5%	0,06W
3840	4822 051 30223	22kΩ	5%	0,06W
3841	4822 051 30153	15kΩ	5%	0,06W
3842	4822 051 30102	1kΩ	5%	0,06W
3843	4822 051 30102	1kΩ	5%	0,06W

3844	4822 051 30101	100Ω	5%	0,06W
3845	4822 051 30471	470Ω	5%	0,06W

## ELECTRICAL PARTSLIST 5DTC MODULE MP3CD Version CD Board

## RESISTORS

3846	4822 051 30102	1k $\Omega$	5%	0,06W
3847	4822 117 12968	820 $\Omega$	5%	0,06W
3848	4822 051 30221	220 $\Omega$	5%	0,06W
3849	4822 051 30471	470 $\Omega$	5%	0,06W
3850	4822 117 12925	47k $\Omega$	1%	0,06W
3851	4822 117 12968	820 $\Omega$	5%	0,06W
3852	4822 051 30221	220 $\Omega$	5%	0,06W
3854	4822 117 12925	47k $\Omega$	1%	0,06W
3855	4822 051 30393	39k $\Omega$	5%	0,06W
3856	4822 051 30472	4,7k $\Omega$	5%	0,06W
3857	4822 051 30008	CHIP JUMPER 0603		
3859	4822 117 13632	100k $\Omega$	1%	0,06W
3860	4822 051 30123	12k $\Omega$	5%	0,06W
3861	4822 051 30153	15k $\Omega$	5%	0,06W
3862	4822 051 30393	39k $\Omega$	5%	0,06W
3864	4822 051 30333	33k $\Omega$	5%	0,06W
3865	4822 051 30181	180 $\Omega$	5%	0,06W
3866	4822 117 13608	4,7 $\Omega$	5%	0,06W
3867	4822 051 30333	33k $\Omega$	5%	0,06W
3868	4822 051 30183	18k $\Omega$	5%	0,06W
3869	4822 051 30183	18k $\Omega$	5%	0,06W
3870	4822 051 30681	680 $\Omega$	5%	0,06W
3871	4822 051 30181	180 $\Omega$	5%	0,06W
3872	4822 051 30272	2,7k $\Omega$	5%	0,06W
3873	4822 051 30333	33k $\Omega$	5%	0,06W
3874	4822 051 30333	33k $\Omega$	5%	0,06W
3875	4822 051 30183	18k $\Omega$	5%	0,06W
3876	4822 051 30183	18k $\Omega$	5%	0,06W
3877	4822 051 30681	680 $\Omega$	5%	0,06W
3878	4822 051 30471	470 $\Omega$	5%	0,06W
3879	4822 051 30223	22k $\Omega$	5%	0,06W
3880	4822 051 30339	33 $\Omega$	5%	0,06W
3881	4822 051 30151	150 $\Omega$	5%	0,06W
3883	4822 051 30472	4,7k $\Omega$	5%	0,06W
3884	4822 051 30472	4,7k $\Omega$	5%	0,06W
3888	4822 051 30103	10k $\Omega$	5%	0,06W
3889	4822 051 30471	470 $\Omega$	5%	0,06W
3890	4822 051 30471	470 $\Omega$	5%	0,06W
3891	4822 051 30102	1k $\Omega$	5%	0,06W
3892	4822 051 30102	1k $\Omega$	5%	0,06W
3893	4822 051 30471	470 $\Omega$	5%	0,06W
3895	4822 051 30273	27k $\Omega$	5%	0,06W
3896	4822 051 30101	100 $\Omega$	5%	0,06W
3897	4822 051 30333	33k $\Omega$	5%	0,06W
3898	4822 051 30221	220 $\Omega$	5%	0,06W
3899	4822 051 30272	2,7k $\Omega$	5%	0,06W
3901	4822 051 30561	560 $\Omega$	5%	0,06W
3902	4822 117 11139	1,5k $\Omega$	1%	0,1W
3903	4822 051 30332	3,3k $\Omega$	5%	0,06W
3904	4822 051 30332	3,3k $\Omega$	5%	0,06W
3905	4822 051 30681	680 $\Omega$	5%	0,06W
3906	4822 051 30471	470 $\Omega$	5%	0,06W
3907	4822 117 12968	820 $\Omega$	5%	0,06W
3908	4822 051 30222	2,2k $\Omega$	5%	0,06W
3909	4822 117 13632	100k $\Omega$	1%	0,06W
3910	4822 051 30471	470 $\Omega$	5%	0,06W
3912	4822 051 30221	220 $\Omega$	5%	0,06W
3916	4822 051 30471	470 $\Omega$	5%	0,06W
3917	4822 117 13608	4,7 $\Omega$	5%	0,06W
3918	4822 051 30103	10k $\Omega$	5%	0,06W
3919	4822 051 30153	15k $\Omega$	5%	0,06W
3920	4822 051 30101	100 $\Omega$	5%	0,06W
3923	4822 051 30103	10k $\Omega$	5%	0,06W

## RESISTORS

3925	4822 051 30101	100 $\Omega$	5%	0,06W
3926	4822 051 30101	100 $\Omega$	5%	0,06W
3927	4822 051 30101	100 $\Omega$	5%	0,06W
3928	4822 051 30101	100 $\Omega$	5%	0,06W
4807	4822 051 30008	CHIP JUMPER 0603		
4809	4822 051 30008	CHIP JUMPER 0603		
4820	4822 051 30008	CHIP JUMPER 0603		
4824	4822 051 30008	CHIP JUMPER 0603		
4835	4822 051 20008	CHIP JUMPER 0805		
4836	4822 051 20008	CHIP JUMPER 0805		
4837	4822 051 20008	CHIP JUMPER 0805		
4838	4822 051 20008	CHIP JUMPER 0805		
4840	4822 051 20008	CHIP JUMPER 0805		
4841	4822 051 20008	CHIP JUMPER 0805		
4843	4822 051 20008	CHIP JUMPER 0805		

## COILS

1810	2422 540 98519	RESONATOR 8,467MHZ
5001	2422 549 44607	FERRITE BEAD
5002	2422 549 44607	FERRITE BEAD

## DIODES

6877	9322 129 34685	BZX284-C3V9
------	----------------	-------------

## TRANSISTORS

7875	5322 130 42755	BC847C
7876	5322 130 42755	BC847C
7877	5322 130 42755	BC847C
7878	5322 130 42755	BC847C
7879	5322 130 60123	BC807-40

## INTEGRATED CIRCUITS

7800	9352 684 20557	SAA7325H/T/M2B, Signal Processor
7801	4822 209 72554	MC7808CT 8V Regulator
7802	9322 181 79668	MM1469PH Motor Driver
7810	5322 209 82941	LM358D, Dual Opamp
7811	5322 209 82941	LM358D, Dual Opamp

**ELECTRICAL PARTSLIST 5DTC MODULE MP3CD Version Control Board****MECHANICAL PARTS****3103 308 54710 5DTC Module** (mechanic w/o electronic)**MISCELLANEOUS**

1801 2422 025 17065 FFC-CONNECTOR 16P, top entry  
 1802 2422 025 17788 FFC-CONNECTOR 8P, top entry  
 8021 3103 308 93110 FFC-CABLE 16Pin 60mm AD

**CAPACITORS**

2800© 4822 126 13879 220nF 20% 16V  
 2801© 2238 586 59812 100nF 10% 50V  
 2802© 2238 586 59812 100nF 10% 50V  
 2803© 2238 586 59812 100nF 10% 50V  
 2808 4822 124 40433 47µF 20% 25V

2810© 3198 017 34730 47nF 10% 16V  
 2811© 2238 586 59812 100nF 10% 50V  
 2812© 2238 586 59812 100nF 10% 50V  
 2813© 2238 586 59812 100nF 10% 50V  
 2814© 2238 586 59812 100nF 10% 50V

**RESISTORS**

3800© 4822 051 30472 4,7kΩ 5% 0,06W  
 3801© 4822 051 30472 4,7kΩ 5% 0,06W  
 3802© 4822 051 30472 4,7kΩ 5% 0,06W  
 3803© 4822 051 30472 4,7kΩ 5% 0,06W  
 3804© 4822 051 30472 4,7kΩ 5% 0,06W

3805© 4822 051 30472 4,7kΩ 5% 0,06W  
 3806© 4822 051 30472 4,7kΩ 5% 0,06W  
 3807© 4822 051 30472 4,7kΩ 5% 0,06W  
 3808© 4822 051 30472 4,7kΩ 5% 0,06W  
 3809© 4822 051 30472 4,7kΩ 5% 0,06W

3810© 4822 051 30103 10kΩ 5% 0,06W  
 3811© 4822 051 30154 150kΩ 5% 0,0625W  
 3815© 5322 117 13057 820Ω 1% 0,06W  
 3816© 4822 051 30479 47Ω 5% 0,06W  
 3818© 4822 051 30479 47Ω 5% 0,06W

3819© 5322 117 13057 820Ω 1% 0,06W  
 3820© 5322 117 13057 820Ω 1% 0,06W  
 3821© 4822 051 30479 47Ω 5% 0,06W  
 3823© 4822 051 30479 47Ω 5% 0,06W  
 3824© 5322 117 13057 820Ω 1% 0,06W

3826▲ 4822 117 12148 1,5Ω 5% 0,33W  
 3827© 4822 051 30101 100Ω 5% 0,06W  
 3828© 4822 051 30101 100Ω 5% 0,06W  
 3829© 4822 051 30101 100Ω 5% 0,06W  
 3830© 4822 051 30103 10kΩ 5% 0,06W

3831© 4822 051 30103 10kΩ 5% 0,06W  
 3832© 4822 051 30272 2,7kΩ 5% 0,06W  
 3833© 4822 051 30272 2,7kΩ 5% 0,06W  
 3834© 4822 051 30272 2,7kΩ 5% 0,06W  
 3835© 4822 051 30272 2,7kΩ 5% 0,06W

3836© 4822 051 30272 2,7kΩ 5% 0,06W  
 3837© 4822 051 30272 2,7kΩ 5% 0,06W  
 3838© 4822 051 30103 10kΩ 5% 0,06W  
 3839© 4822 051 30272 2,7kΩ 5% 0,06W  
 3840© 4822 051 30272 2,7kΩ 5% 0,06W

3841© 4822 051 30103 10kΩ 5% 0,06W  
 3842© 4822 051 30103 10kΩ 5% 0,06W  
 3845© 4822 051 20159 15Ω 5% 0,1W  
 3850© 4822 117 12706 10kΩ 1% 0,06W  
 3851© 4822 117 12706 10kΩ 1% 0,06W

3852© 4822 117 12706 10kΩ 1% 0,06W  
 3853© 4822 117 12706 10kΩ 1% 0,06W  
 3854© 4822 117 12706 10kΩ 1% 0,06W

**RESISTORS**

3855© 4822 117 12706 10kΩ 1% 0,06W  
 3856© 4822 117 12706 10kΩ 1% 0,06W  
 3857© 4822 117 12706 10kΩ 1% 0,06W  
 3858© 4822 051 30102 1kΩ 5% 0,06W  
 3859© 4822 051 30103 10kΩ 5% 0,06W

3860© 5322 117 13017 100Ω 1% 0,06W  
 3861© 2322 704 62002 2kΩ 1% 0,06W  
 3862© 4822 117 12706 10kΩ 1% 0,06W  
 3863 4822 053 10228 2,2Ω 5% 1W  
 4800© 4822 051 30008 CHIP JUMPER 0603

4802© 4822 051 30008 CHIP JUMPER 0603  
 4803© 4822 051 30008 CHIP JUMPER 0603  
 4804© 4822 051 30008 CHIP JUMPER 0603  
 4805© 4822 051 20008 CHIP JUMPER 0805  
 4806© 4822 051 30008 CHIP JUMPER 0603

4807© 4822 051 30008 CHIP JUMPER 0603  
 4808© 4822 051 30008 CHIP JUMPER 0603  
 4809© 4822 051 20008 CHIP JUMPER 0805  
 4810© 4822 051 20008 CHIP JUMPER 0805  
 4811© 4822 051 30008 CHIP JUMPER 0603

4812© 4822 051 30008 CHIP JUMPER 0603  
 4813© 4822 051 30008 CHIP JUMPER 0603  
 4814© 4822 051 30008 CHIP JUMPER 0603  
 4816© 4822 051 20008 CHIP JUMPER 0805  
 4817© 4822 051 20008 CHIP JUMPER 0805

4818© 4822 051 20008 CHIP JUMPER 0805  
 4819© 4822 051 30008 CHIP JUMPER 0603  
 4820© 4822 051 30008 CHIP JUMPER 0603  
 4821© 4822 051 20008 CHIP JUMPER 0805  
 4822© 4822 051 20008 CHIP JUMPER 0805

**COILS**

1800 4822 242 72066 CERAMIC FILTER 8,0MHz

**TRANSISTORS**

7806© 3198 010 42320 BC857BW

**INTEGRATED CIRCUITS**

7800 4822 209 72042 MC78L05ACP, STABILIZER  
 7801© 3103 307 01640 TMP87P809M Microcontroller  
 7803 4822 209 62059 TCA0372DP1, 2-FOLD OP-AMP.  
 7805 4822 209 62059 TCA0372DP1, 2-FOLD OP-AMP.



**ELECTRICAL PARTSLIST 5DTC MODULE MP3CD Version MP3 Board****MISCELLANEOUS**

1451	2422 025 17303	FFC-CONNECTOR 19P,side entry
------	----------------	------------------------------

**CAPACITORS**

2450	2238 586 59812	100nF	10%	50V
2451	3198 017 41050	1µF	20%	10V
2452	3198 017 41050	1µF	20%	10V
2453	2238 586 59812	100nF	10%	50V
2454	2238 586 59812	100nF	10%	50V

2455	2238 586 59812	100nF	10%	50V
2456	2238 586 59812	100nF	10%	50V
2457	5322 126 11583	10nF	10%	63V
2458	5322 126 11583	10nF	10%	63V
2459	3198 017 41050	1µF	20%	10V

2460	2238 586 59812	100nF	10%	50V
2461	4822 124 81059	220µF	20%	4V
2462	3198 017 41050	1µF	20%	10V
2463	3198 017 41050	1µF	20%	10V
2464	2238 586 59812	100nF	10%	50V

2465	2238 586 59812	100nF	10%	50V
2466	2238 586 59812	100nF	10%	50V
2467	3198 017 41050	1µF	20%	10V
2468	3198 017 41050	1µF	20%	10V
2469	2238 586 59812	100nF	10%	50V

2470	2238 586 59812	100nF	10%	50V
2471	2238 586 59812	100nF	10%	50V

**RESISTORS**

3449	4822 051 30101	100Ω	5%	0,06W
3450	4822 117 12971	15Ω	5%	0,06W
3451	4822 117 12971	15Ω	5%	0,06W
3452	4822 051 30101	100Ω	5%	0,06W
3453	4822 051 30109	10Ω	5%	0,06W

3454	4822 117 12971	15Ω	5%	0,06W
3455	4822 051 30102	1kΩ	5%	0,06W
3456	4822 051 30102	1kΩ	5%	0,06W
3457	5322 117 13051	680Ω	1%	0,06W
3458	5322 117 13061	180Ω	1%	0,06W

3459	4822 051 30221	220Ω	5%	0,06W
3460	4822 051 30102	1kΩ	5%	0,06W
3461	4822 051 30479	47Ω	5%	0,06W
3462	4822 051 30101	100Ω	5%	0,06W
3463	4822 051 30101	100Ω	5%	0,06W

3464	4822 051 30103	10kΩ	5%	0,06W
3465	4822 051 30101	100Ω	5%	0,06W
3466	4822 051 30471	470Ω	5%	0,06W
3467	4822 051 30103	10kΩ	5%	0,06W
3468	4822 051 30103	10kΩ	5%	0,06W

3469	4822 051 30101	100Ω	5%	0,06W
3470	4822 117 12971	15Ω	5%	0,06W
3471	4822 051 30339	33Ω	5%	0,06W
3472	4822 051 30154	150kΩ	5%	0,06W
3473	4822 117 13632	100kΩ	1%	0,06W

3474	4822 117 12971	15Ω	5%	0,06W
3475	4822 051 30101	100Ω	5%	0,06W
3476	4822 051 30101	100Ω	5%	0,06W
3477	4822 051 30471	470Ω	5%	0,06W
3478	4822 051 30471	470Ω	5%	0,06W

3479	4822 051 30471	470Ω	5%	0,06W
3480	4822 051 30101	100Ω	5%	0,06W
3481	4822 051 30101	100Ω	5%	0,06W
3482	4822 051 30471	470Ω	5%	0,06W
3483	4822 051 30101	100Ω	5%	0,06W

**RESISTORS**

3484	4822 117 12971	15Ω	5%	0,06W
3486	4822 051 30101	100Ω	5%	0,06W
3488	4822 117 13632	100kΩ	1%	0,06W
3489	4822 051 30103	10kΩ	5%	0,06W
3490	4822 051 30101	100Ω	5%	0,06W

3491	4822 051 30479	47Ω	5%	0,06W
3492	4822 051 30105	1MΩ	5%	0,06W
3493	4822 051 30103	10kΩ	5%	0,06W
3494	4822 051 30103	10kΩ	5%	0,06W
3495	4822 051 30103	10kΩ	5%	0,06W

3497	4822 051 30103	10kΩ	5%	0,06W
3498	4822 051 30332	3,3kΩ	5%	0,06W
3499	4822 051 30103	10kΩ	5%	0,06W
4450	4822 051 30008			CHIP JUMPER 0603

**COILS**

1460	4822 242 10989	CER.RES. 16,9MHz
5450	4822 157 11074	100µH

**DIODES**

6450	4822 130 11411	BZX284-C3V3
6451	4822 130 11366	BZX284-C3V9
7454	4822 130 34174	BZX79-B4V7

**TRANSISTORS**

7452	3198 010 42310	BC847BW
7453	3198 010 42310	BC847BW
7456	3198 010 42310	BC847BW
7460	3198 010 42310	BC847BW

**INTEGRATED CIRCUITS**

7451	not available	please order complete MP3 Board
7455	4822 209 17108	LM317LD Voltage Regulator
7457	9352 456 50115	HC1G04, Inverter
7458	9322 130 41668	M24C64, EEPROM

**3103 308 67020 MP3 Board**

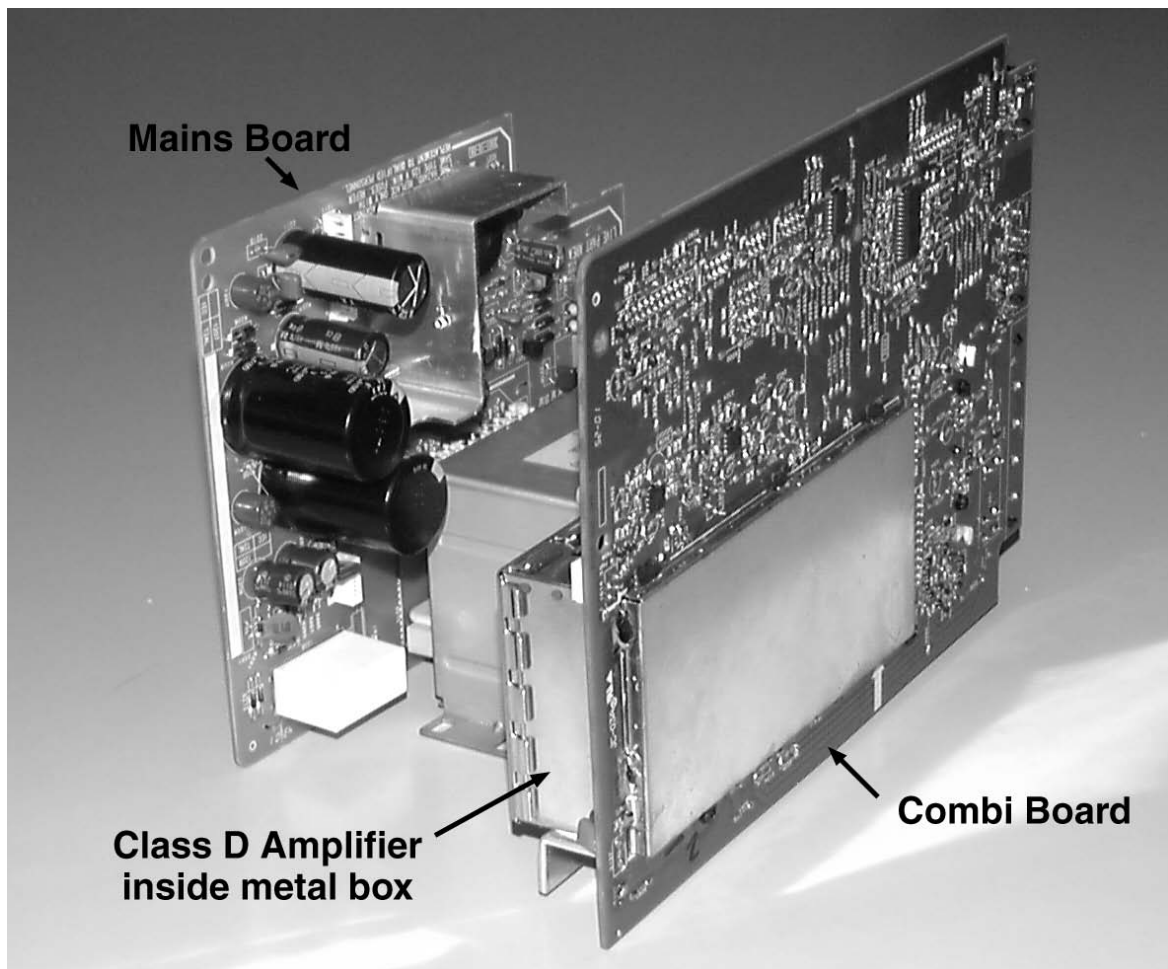

# ***Power 2003 Module***

## ***(100W Class D)***

stage M.5/C.2

### **TABLE OF CONTENTS**

Brief Circuit Description .....	11-2
Service Hints .....	11-4
<b>COMBI BOARD</b>	
<b>Circuit Diagram</b>	
Overview .....	11-7
Source Selector part .....	11-8
Audio Frequency & Logic part.....	11-9
Oscillator & Pre-Amplifier part.....	11-10
Amplifier part Left Channel .....	11-11
Amplifier part Right Channel .....	11-12
<b>Component Layout</b>	
Copperside view .....	11-13
Componentside view.....	11-14
<b>MAINS BOARD</b>	
Component Layout .....	11-15
Circuit Diagram .....	11-16
Partslist.....	11-17

## Class-D Circuit Description (BASED ON POWER 2003 MODULE -100W CLASS D)

Basically Class-D works by transforming the LF audio input to a square wave signal with a fixed frequency and a variable duty cycle. See simplified drawing below.

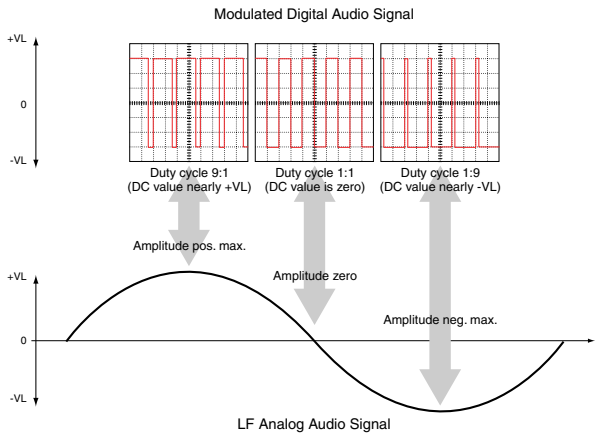

The amplitude of the square wave signal is equal to the supply voltage of the amplifier. With the audio signal the square wave signal is pulse-width modulated.

Compared to a conventional power amplifier the benefits of the Class D amplifier are:

- higher efficiency
- lower power dissipation
- smaller cooling fin
- smaller mains transformer

Disadvantage of this concept is:

- 500kHz square wave signal with high current requires a shielding box to suppress radiation.

### Required Circuitries:

#### • 500kHz square wave oscillator.

The oscillator frequency is created by 7312-C; it is a dual-frequency oscillator with ceramic resonators 5300 and 5302, which resonate at 500kHz and 425kHz respectively. The resonators are switched by transistors 7309 and 7316, controlled by the "OZ\_SW" line from the port expander 7406.

The reason for 2 frequencies is to avoid tuner disturbances in the AM-band.

The oscillator signal is shaped to square wave with 7312-B, afterwards buffered and fed to the amplifier modulators (ROZ to the right channel, LOZ to the left). One channel gets inverted clock to balance supply loading.

#### • Modulator

The modulator forms the pulse width modulated signal. For each channel a separate modulation is required.

#### • Power FETs

The FETs require drivers which supply the gates. One for the high-side-FET and one for the low-side-FET. Because of the different supply voltages also an additional level shifter is necessary per driver.

#### • Output filter

The output filter is necessary to block the 500kHz square wave signal from the speaker.

It consists of a series-mode coil 5101 and a capacity of approx. 550nF (2116, 2134), which forms a Chebycheff filter with 40kHz cut-off frequency at 6Ω load. For EMC reasons both, the speaker output and the return ground are fed through a common mode coil 5102, the filter is further improved by splitting the output capacity into 2116 before and 2134 after the common mode coil.

### Blockdiagram Class D

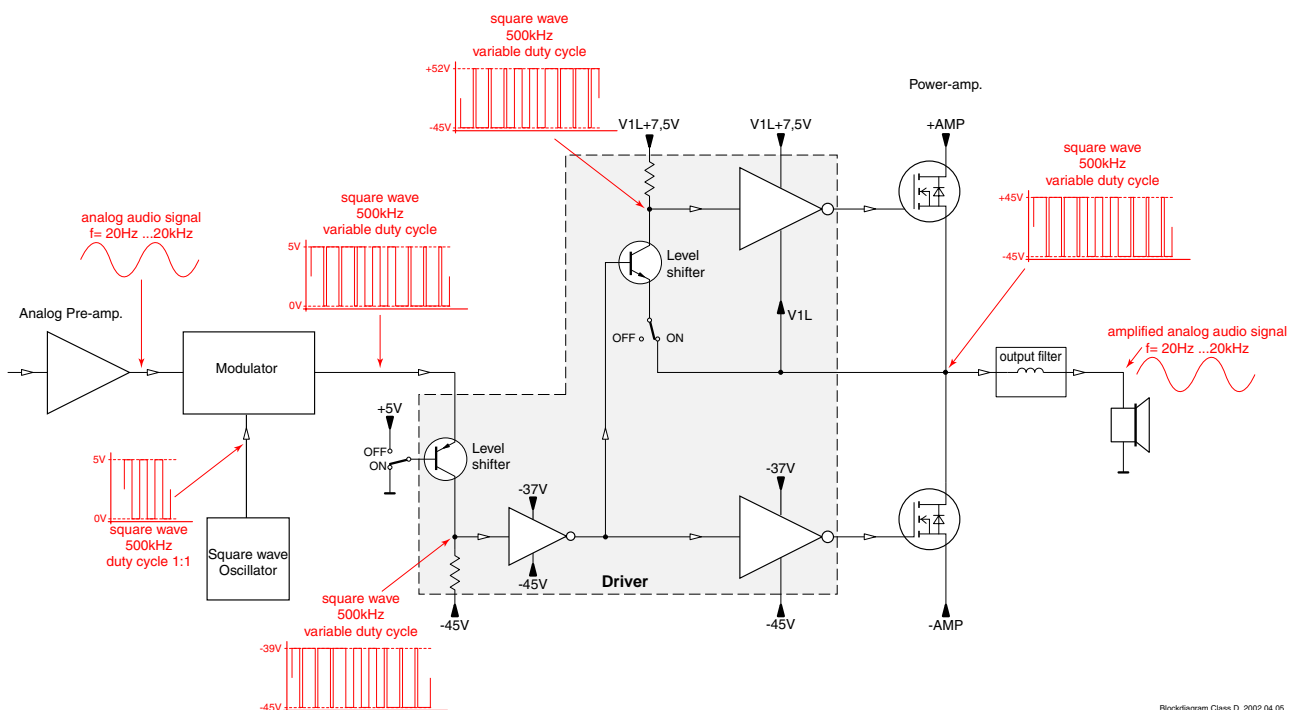

All above mentioned circuitries are located inside the metal shielding box.

## Class-D Circuit Description (BASED ON POWER 2003 MODULE - 100W CLASS D)

---

### Functional Description:

Refers to the left channel in schematic diagrams. The first stage of the modulator is an error integrator which compares the input to the (22 dB amplified) output signal of the power stage. The difference is leading to a current, which loads the integrator 7122-A. The second stage (7122-B) is again integrating, thus creating high gain at low frequency, which leads to high feedback and low distortion. The next stage is a comparator, which compares the integrated voltage to a triangle wave - thus creating a voltage controlled duty cycle. The comparator is realized by cascaded gates. At pin 18 of IC7122 there is a square wave with the same frequency and duty cycle as the desired output.

The next task is to feed this information to the output FETs. Both FETs are n-channel types, so they are modulated by feeding the gate in respect to the source connection. We use inverters 74LV14 as drivers. The driver for the low-side FET (7121) is supplied by the negative supply -VL2 and a voltage +VL generated by 7115 and 6113, which is 7.5V higher than -VL2. The digital signal is level-shifted by 7128 to the negative supply reference. 3142, 6111 and 2126 together is a delay circuit for rising edges by approx. 100ns and 3154, 6109 and 2137 for falling edge by 50ns. This is to compensate the switch-off delay of the FETs and ensures that both FETs are not conducting at the same time. The high-side FET (7109) is controlled by the inverted signal taken from pin 2 of 7118-A, which is level-shifted by transistor 7119. The driver for the high-side FET is supplied by a floating voltage between the amplifier output -V1L and +V1L, created by the charge pump 6110, 2114 regulated by 7114 and 6114 to a 7.5V higher level. The pump is additionally supplied (via 3151) by +45V to ensure supply at start-up (no signal). The necessary delay for the rising edge is generated by the level-shifter (mainly the pull-up 3117) and the input capacity of the driver (pin 13 of 7105-F). The last stage in the gate driver consists of three gates in parallel for increased output current for the capacitive load, afterwards comes a 47 $\Omega$  series resistor for soft rising edges and a transistor for very fast falling edges. This combination gives the best compromise of efficiency and radiation.

### Protection Circuits:

The amplifier is protected against low load impedance (including short circuit). Current is sensed by shunts 3101, 3130 in both supplies. Overcurrent at the positive supply is then sensed by 7104, the negative supply overcurrent triggers 7117, which then also triggers 7104. The collector current then triggers the monoflop 7122-E and -F, giving a high pulse at pin 10. This shuts off level-shifter 7128 and triggers transistor 7129, which draws current into the emitter resistors (3134, 3127) of level-shifter 7119, which is therefore also shut off. So both FETs are shut off for approx. 0.2 sec, afterwards the amplifier tries to work again, but if the overload continues the on-time is only a few cycles.

The shut-off mechanism is also used to shut off the amplifier during headphone usage; this is done by pulling pin 13 of 7122-F high. The line "AMP\_OFF" is controlled by the port expander 7406.

The loudspeakers are protected against DC voltages resulting e.g. from defective FETs, voltages higher than  $\pm 2V$  are detected by 7110+7112 and pull down the "DC\_PROT" line, which disables the speaker relay 1201.

The gain of the class-D amplifier is 22dB, adjusted by the feedback resistors 3135, 3136, 3149 and the input resistors 3139, 3340. The input reference voltage for 7122-A is approx. half the supply, therefore 3144, 3148 are used for offset compensation. This compensation can be fine-tuned by the potentiometer 3306 to reach <1mV DC output.

## Service Hints

The analog part of the Combi Board can be repaired without opening the metal shielding box. In case of a 'Class D' problem it is advised to disassemble the board first, desolder the metal bottom of the shielding box and assemble the board again. This takes a few minutes only.

**Attention:** Poor soldering of the metal shielding box results in disturbance of the tuner.

In most cases the FETs 7109 and/or 7121 for the left channel, respectively 7218 and/or 7231 for the right channel will be defective. This can be checked easily with an ordinary Ohm-meter.

### LEFT CHANNEL:

In case **7109** is defect replace following parts: 7109, 7111, 7105, 7119, 7104, 3101, 3103 and 2106

In case **7121** is defect replace following parts: 7121, 7113, 7118, 7117, 3129, 3130 and 2118

### RIGHT CHANNEL:

In case **7218** is defect replace following parts: 7218, 7221, 7209, 7228, 7208, 3205, 3209 and 2206

In case **7231** is defect replace following parts: 7231, 7210, 7235, 7227, 3241, 3243 and 2220

If none of the FETs is defective the fault is most probably located in the modulator. To check the operation - follow the given signals.

General description of Oscilloscope setup:

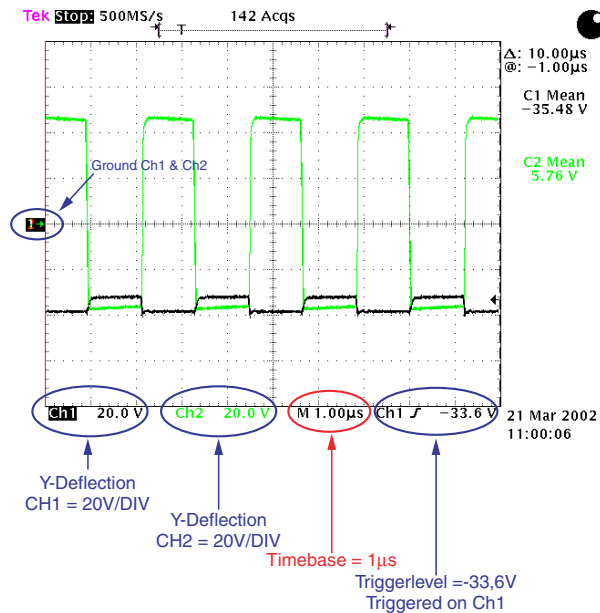

The following signals are measured on condition:  
 AUX in = 500mV/1kHz, Volume = -28dB  
 Load = 2 x 6Ω

Measuring point (A) can be found on circuit diagram [3].

All other measuring points are shown on circuit diagram [4] respectively [5].

Measuring point (A): Output pre-amplifier

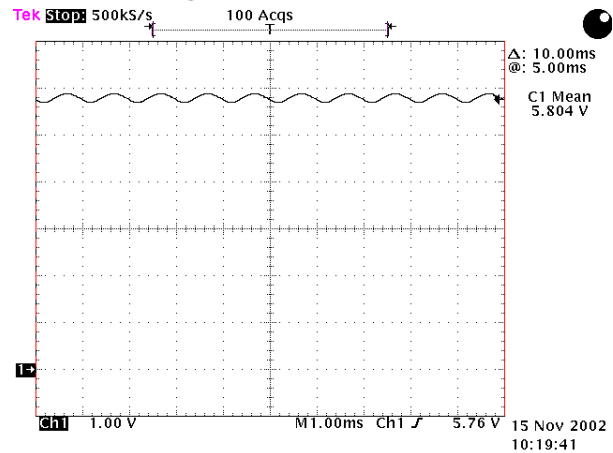

Normal analog signal measured (1kHz- Timebase 1µs). If this signal can't be measured - the fault is outside the shielding box.

Measuring point (B): Input Modulator

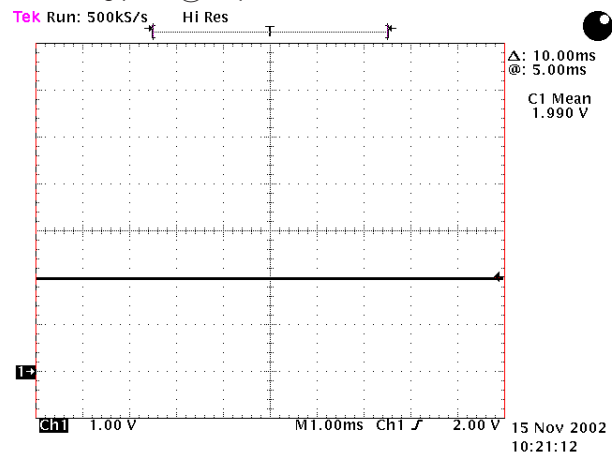

The 1kHz signal not visible anymore. Reducing the timebase to 1µs shows the oscillogram below.

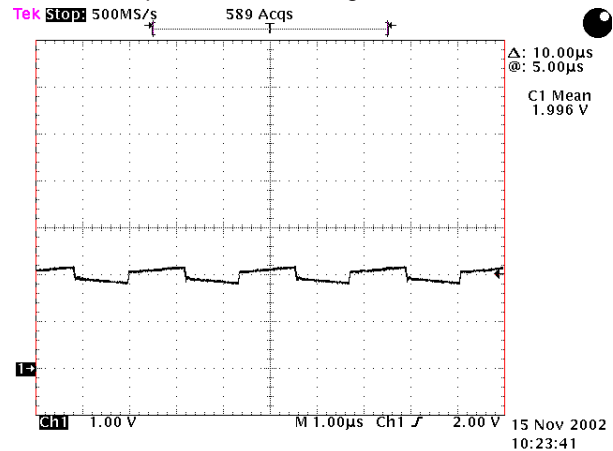

## Service Hints

Measuring point (C):

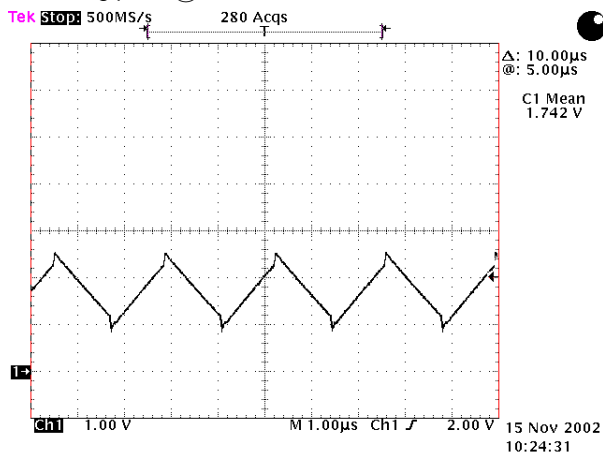

The first stage of the modulator is an integrator. An integrated rectangle results in a triangle.

Measuring point (D):

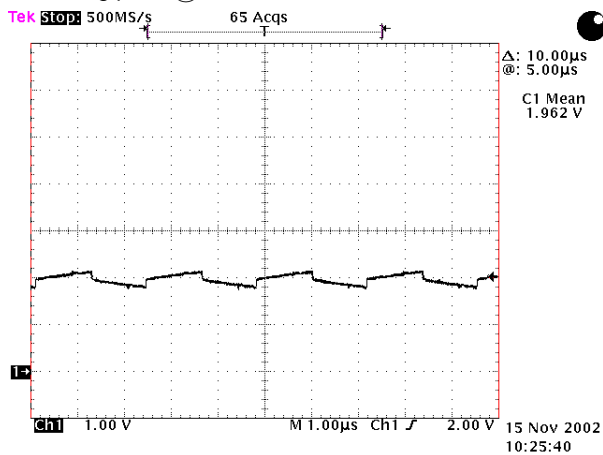

The oscillator signal (squarewave) is fed to the second integrator (7122-B).

Measuring point (E):

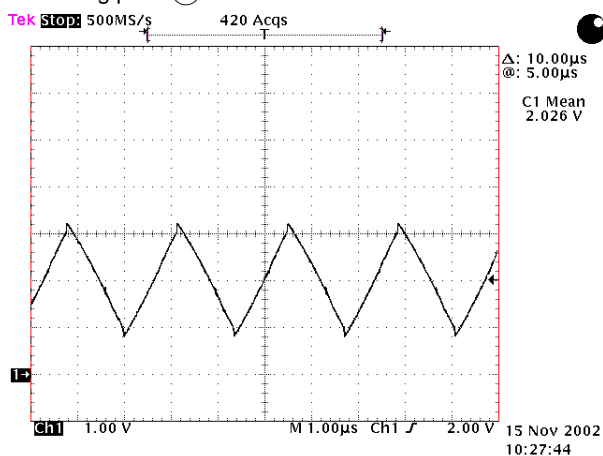

The integrated rectangle results in a triangle. 7122-C and 7122-F work as a comparator.

Measuring point (F): Output modulator

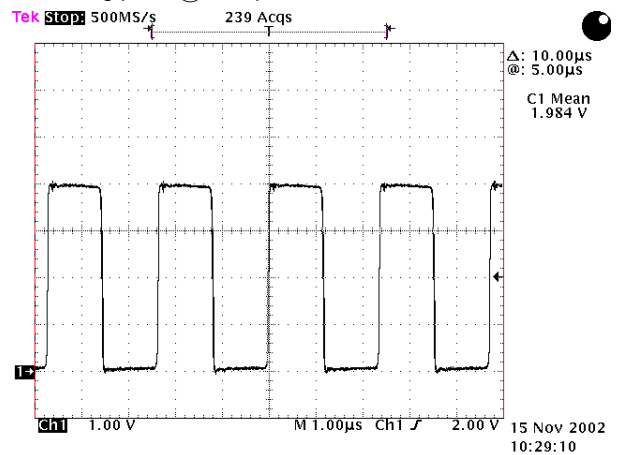

In this pulse width modulated square wave the analog Audio signal is included. Measurements with an analog scope will show a jitter on the falling edge.

The modulator frequency is still fixed to 500kHz. Similar to a frequency modulation - in this case the amplitude of the analog audio signal varies the pulse width, the frequency defines the speed.

Measuring point (G):

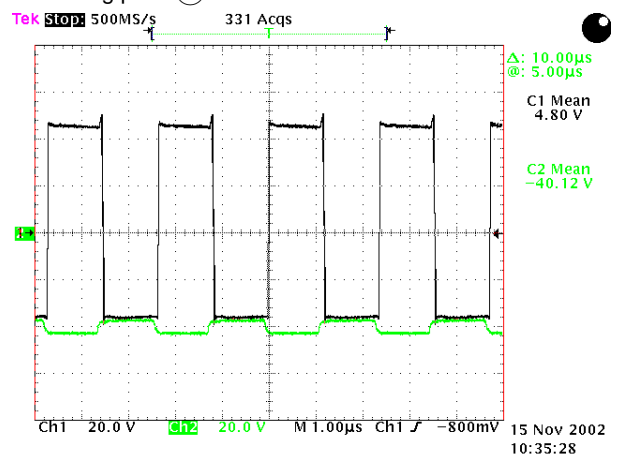

The low-side driver signal (Ch1) is the modulator output level-shifted by transistor 7128. The high-side driver signal (Ch2) is the inverted low-side driver signal level-shifted by transistor 7119.

Service Hints

Measuring point (H): gate-signal of the FETs

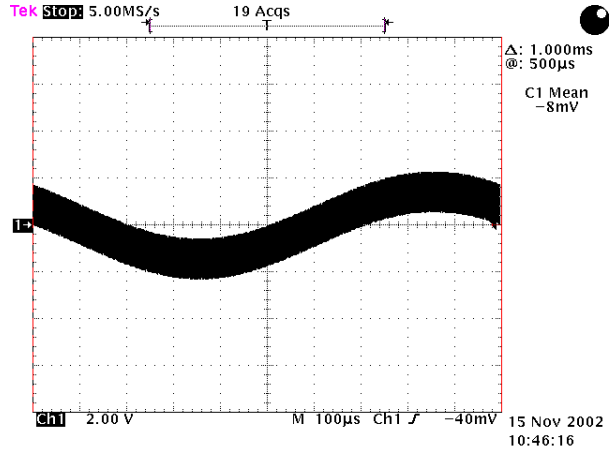
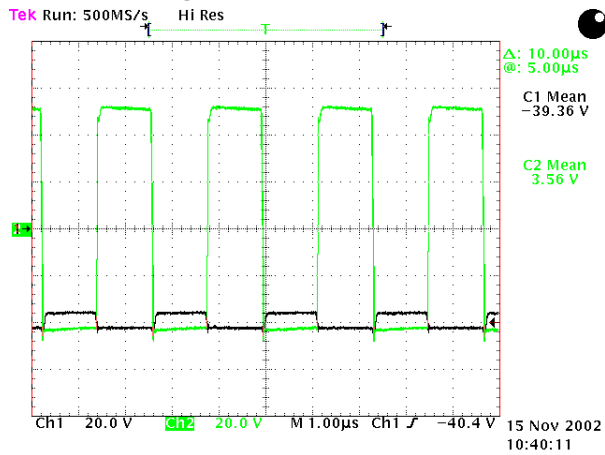

Measuring point (I):

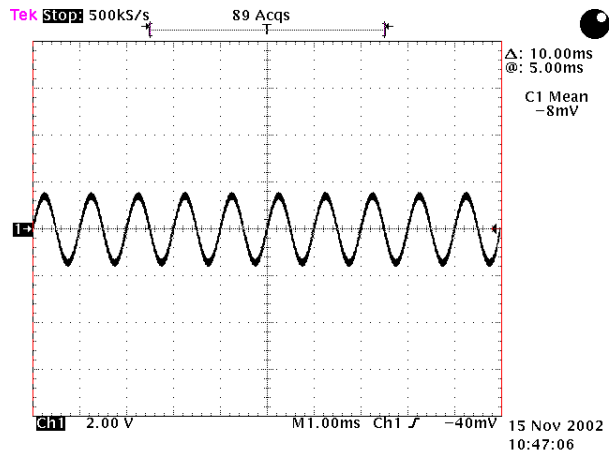
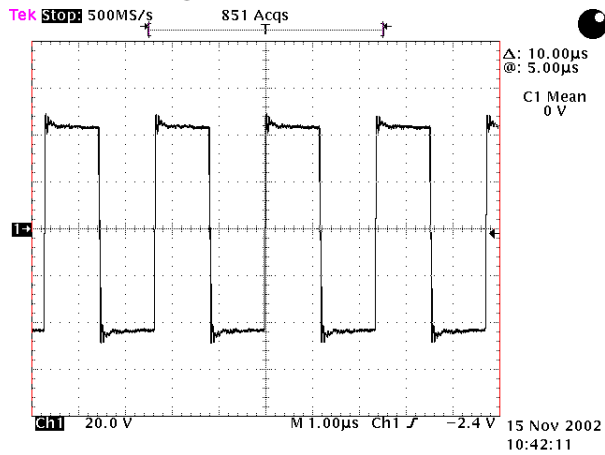

Digital output signal.

Measuring point (J):

The following three signals are measured after output filter 5101 with different timebases.

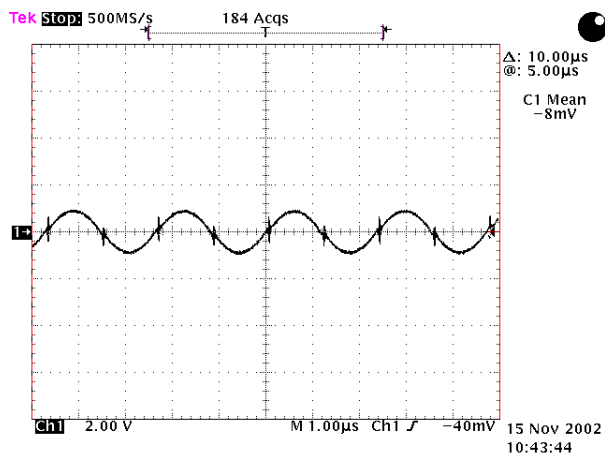

Measuring point (K):

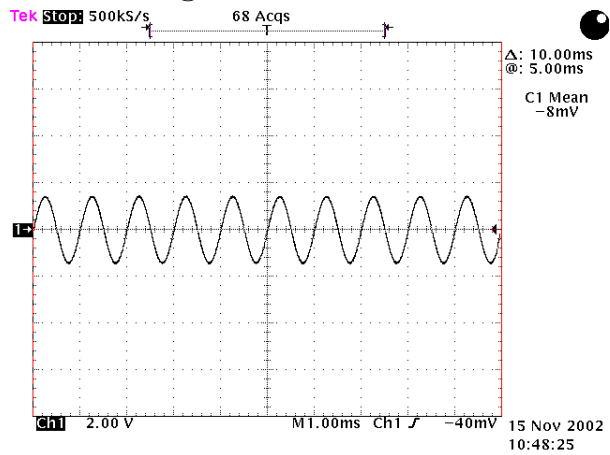

After common mode coil 5102 - the audio signal is restored.

### Power 2003 100W Class D Combi Board Circuit Diagram Overview

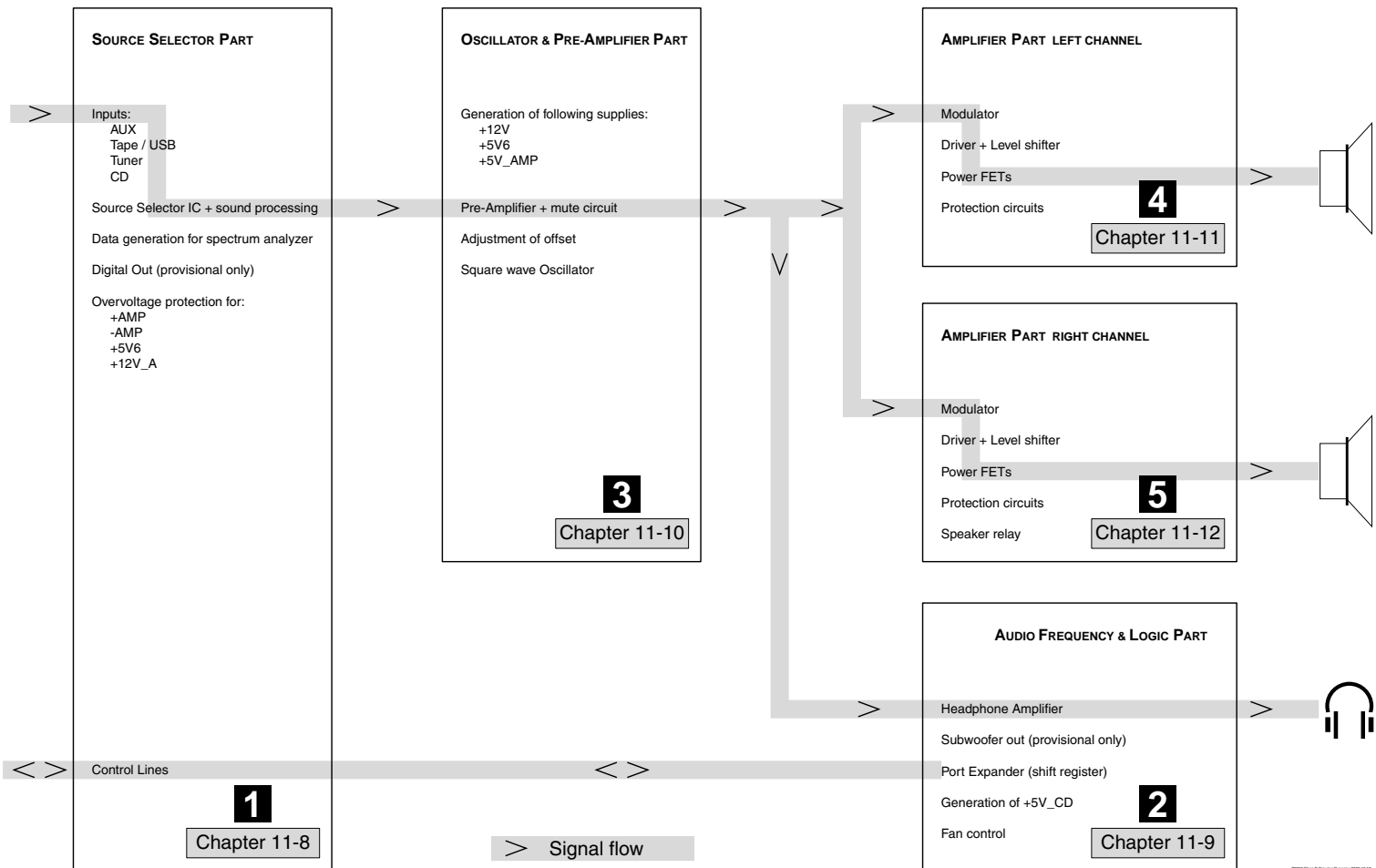



1005 A1	1022 B1	2528 A3	2537 B3	2548 D10	2556 E3	2564 G5	2572 H9	2582 D12	3518 A2	3526 B10	3534 C5	3549 E6	3557 F6	3566 G11	3574 H8	6500 C3	6508 D13	7505 B10
1006 A15	1026 D15	2529 A12	2536 B13	2549 D19	2557 F3	2566 G6	2573 H10	2583 A2	3519 A3	3527 B3	3535 C8	3548 E5	3556 F13	3565 G13	3573 H6	6501 C5	6509 D15	7506 B12
1010 B15	1011 C1	2531 A2	2539 C11	2550 D8	2558 F11	2566 G8	2574 H9	3504 A3	3520 A3	3528 B11	3536 C8	3551 E10	3559 F14	3568 G6	3576 H7	6502 F14	7502 A A12	7508 E7
1011 C15	2500 A3	2532 A13	2540 C3	2551 D9	2559 F3	2567 G6	2575 H9	3508 E2	3524 B2	3532 B9	3539 B9	3550 F6	3558 F16	3567 G12	3575 H6	6503 G13	7505 B B12	7509 B12
1012 G15	2519 A1	2533 B13	2541 D6	2552 E8	2560 G4	2568 G12	2576 H7	3507 F12	3522 A2	3530 B13	3542 D7	3553 F6	3561 G12	3570 G13	3578 H9	6504 G13	7502 C B12	7510 E13
1013 D1	2520 A2	2534 B3	2542 D7	2553 E3	2561 G4	2569 G8	2577 H6	3514 A2	3523 B2	3531 B9	3543 D9	3554 F6	3562 G13	3571 G11	3579 H10	6505 G12	7505 D F12	7511 E13
1018 F1	2526 A13	2535 B3	2543 D8	2554 E2	2562 G5	2570 G10	2578 H7	3515 A13	3524 B9	3532 B10	3544 D10	3555 F13	3563 G6	3572 G10	4501 D13	6506 F12	7500 E B11	8001 F14
1020 A15	2527 A14	2536 B9	2546 D8	2555 E6	2563 G5	2571 G11	2581 E13	3517 A14	3525 B9	3533 C2	3545 E3	3556 F13	3564 G6	3573 G11	5500 A13	6507 F12	7500 F A11	

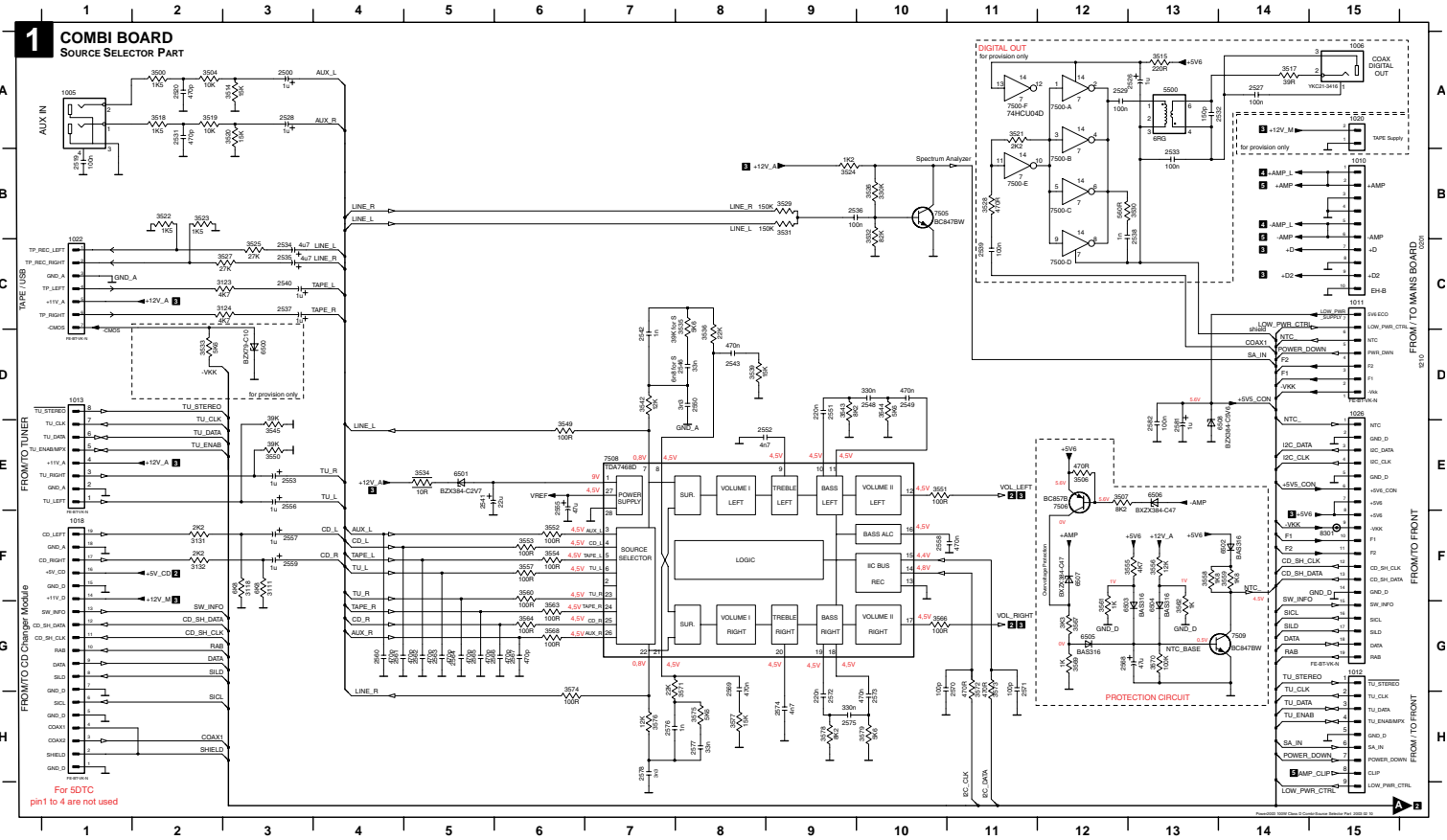

1894 E1	3409 B3	2404 C3	2408 D1	2412 E4	2416 D8	2420 H5	3402 C5	3406 C4	3410 D5	3415 E3	3421 F3	3425 G4	3429 G5	3433 G4	3437 H8	6409 D8	7400-B C3	7405 F4	7409 G9	9288 G8
1814 G1	2401 C3	2405 C4	2409 D3	2413 E1	2417 F4	2421 H14	3403 C2	3407 D2	3411 D7	3416 E2	3422 F4	3426 G4	3430 G5	3434 G10	3438 H10	6401 G14	7402 D8	7406 F12	7410 G4	
1480 D13	2402 B5	2406 D1	2410 D5	2414 F2	2418 H2	3400 B3	3404 C2	3408 D2	3412 D8	3418 F2	3423 F5	3427 G11	3431 G9	3435 H14	3439 H5	6402 H6	7403 F3	7407 G2	7411 H6	
1491 E9	2403 C1	2407 D3	2411 E3	2415 E8	2419 H2	3401 C3	3405 C2	3409 D2	3413 D3	3420 F3	3424 G2	3428 G11	3432 G3	3436 H5	3440 H7	7400-A D3	7404 F2	7408 G3	8302 E12	

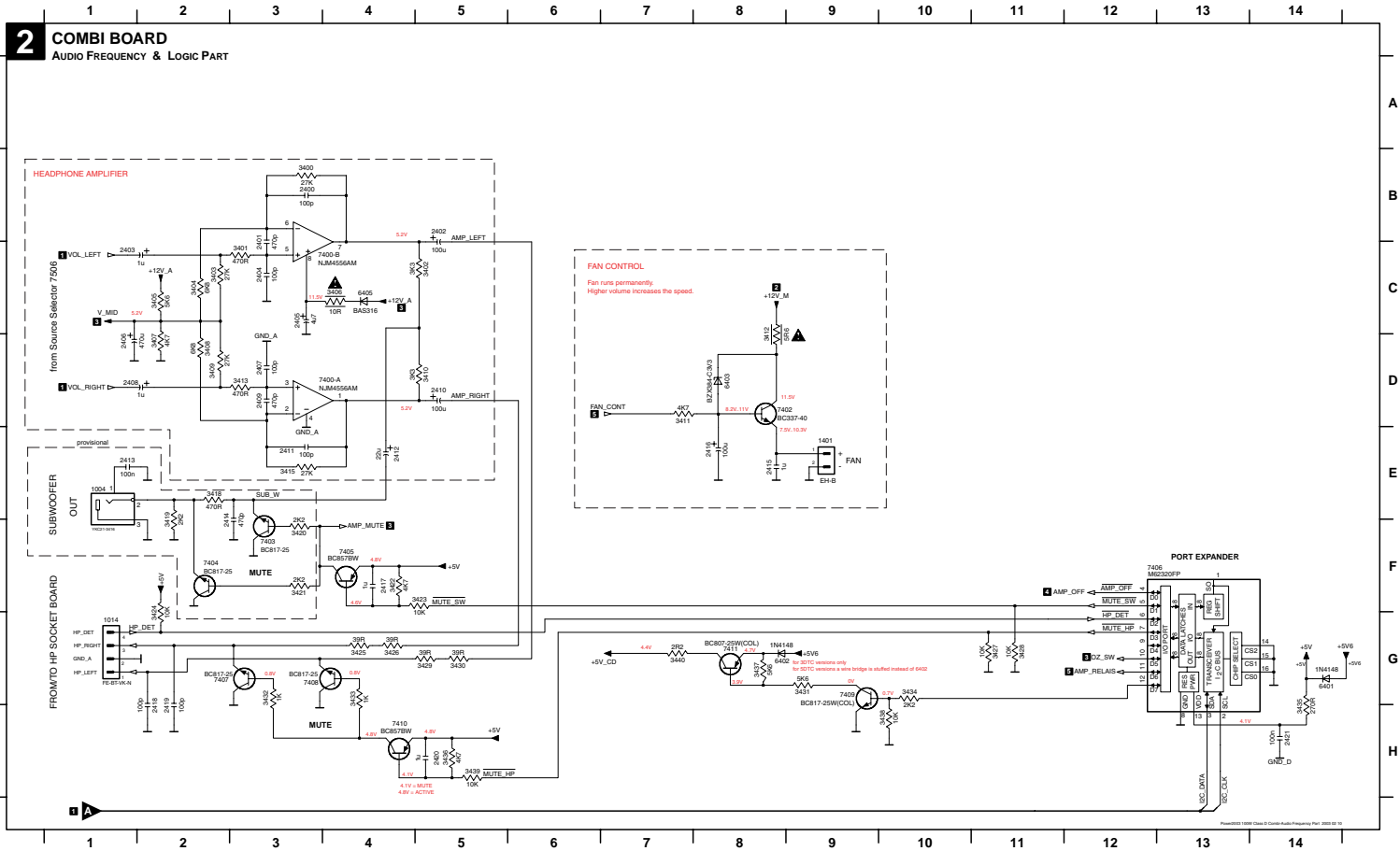

### 3 COMBI BOARD SUPPLY, OSCILLATOR & PRE-AMPLIFIER PART

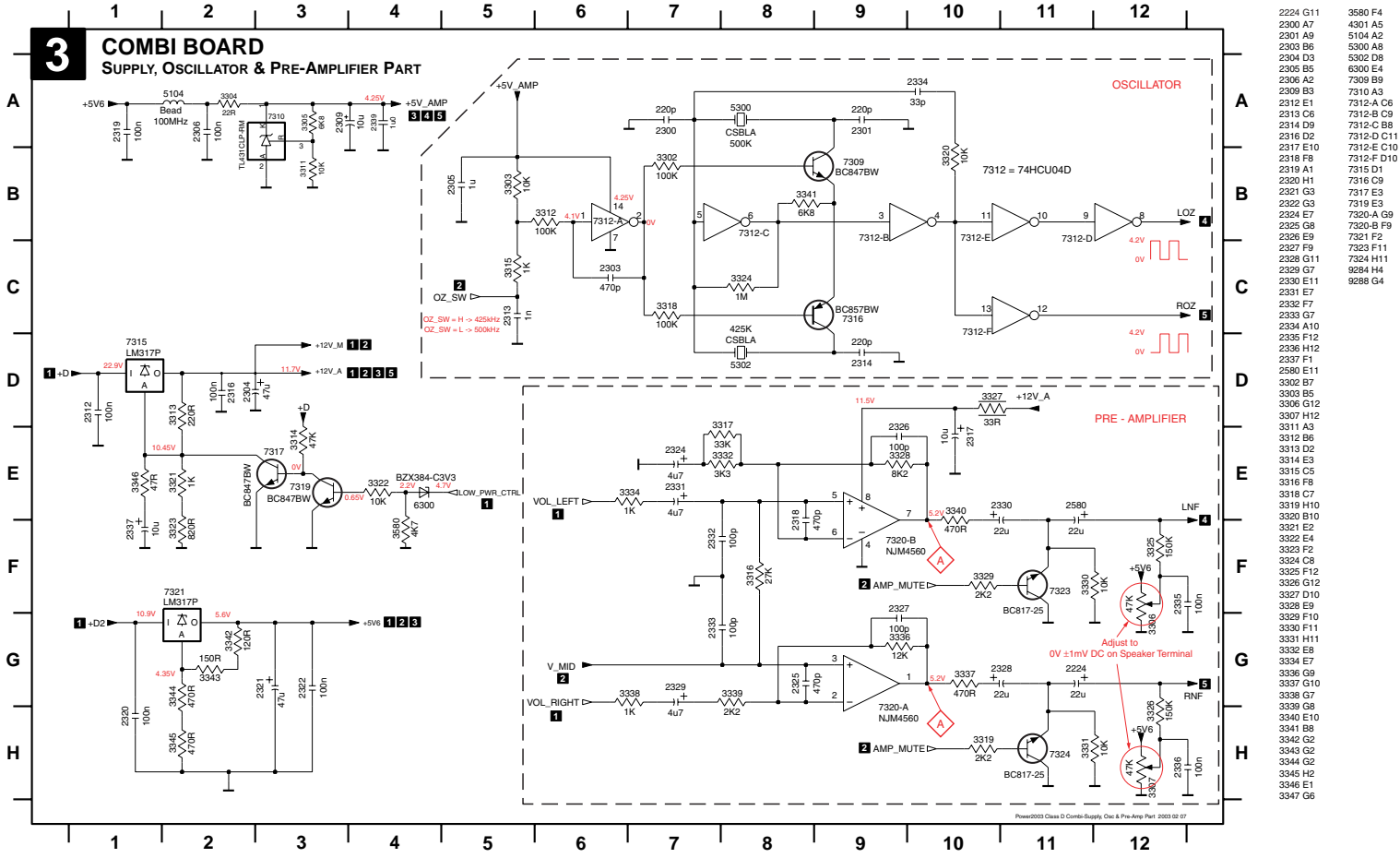

2224 G11	3580 F4
2300 A7	4301 A5
2301 A9	5104 A2
2303 B6	5300 A8
2304 D3	5302 D8
2305 B5	6300 E4
2306 A2	7309 B9
2309 B3	7310 A3
2312 E1	7312-A C6
2313 C6	7312-B C9
2314 D9	7312-C B8
2316 D2	7312-D C11
2317 E10	7312-E C10
2318 F9	7312-F D10
2319 A1	7315 D1
2320 H1	7316 C9
2321 G3	7317 E3
2322 G3	7319 E3
2324 E7	7320-A G9
2325 G8	7320-B F9
2326 E9	7321 F2
2327 F9	7323 F11
2328 G11	7324 H11
2329 G7	9284 H4
2330 E11	9288 G4
2331 F7	
2332 F7	
2333 G7	
2334 A10	
2335 F12	
2336 H12	
2337 F1	
2580 E11	
3302 B7	
3303 B5	
3306 G12	
3307 H12	
3311 A3	
3312 B6	
3313 D2	
3314 E3	
3315 C5	
3316 F9	
3318 C7	
3319 H10	
3320 B10	
3321 E2	
3322 E4	
3323 F2	
3324 C8	
3325 F12	
3326 G12	
3327 D10	
3328 E9	
3329 F10	
3330 F11	
3331 H11	
3332 E8	
3334 E7	
3336 G9	
3337 G10	
3338 G7	
3339 G8	
3340 E10	
3341 B8	
3342 G2	
3343 G2	
3344 G2	
3345 E1	
3346 E1	
3347 G6	

◇ for wave forms see chapter 11-4 Service Hints

**Attention:**  
Adjustment to 0V ±1mV has to be done with 'cold' set.  
After operating a few minutes the value may increase up to 30mV.

2100 A10	2106 B11	2113 D8	2118 F10	2124 F10	2132 C4	3100 A2	3107 D7	3115 E5	3122 C4	3129 F10	3136 E11	3142 F7	3148 F2	3154 B7	5101 D11	6108 B7	7104 B11	7105-E B7	7114 C8	7118-C F7	7121 E10	7122-E A4	7131 C2
2101 A11	2108 A5	2114 D9	2119 F2	2125 E1	2134 E13	3101 B10	3108 A2	3117 B6	3126 F3	3130 F10	3137 E12	3143 E5	3149 F5	3155 E11	5102 D12	6110 D10	7105-A C8	7105-F B6	7115 C4	7118-D E8	7122-A E2	7122-F A5	8201 D12
2102 A9	2110 D6	2115 E12	2120 D1	2126 F7	2135 F3	3102 B2	3109 B9	3119 D8	3128 A1	3133 D7	3139 E2	3144 F2	3151 C9	4101 E12	5103 F10	6111 F7	7105-B B8	7108 B10	7117 F11	7118-E F8	7122-B E3	7128 E5	8202 E12
2103 A9	2111 C3	2116 E11	2121 D4	2128 G10	2136 F10	3103 B10	3110 B5	3120 C3	3127 C2	3134 D6	3140 E3	3146 F5	3152 C9	4102 E12	6108 D8	6113 D4	7105-C B8	7111 C9	7118-A F5	7118-F F8	7122-C E3	7129 E2	8272 A1
2104 A2	2112 D10	2117 E13	2122 C10	2130 G10	2137 B7	3106 B11	3114 A5	3121 C3	3128 E18	3135 E9	3141 C10	3147 B1	3153 D9	5100 A10	6108 C4	6114 E8	7105-D B8	7113 E9	7118-B F6	7119 D7	7122-D E4	7130 A3	

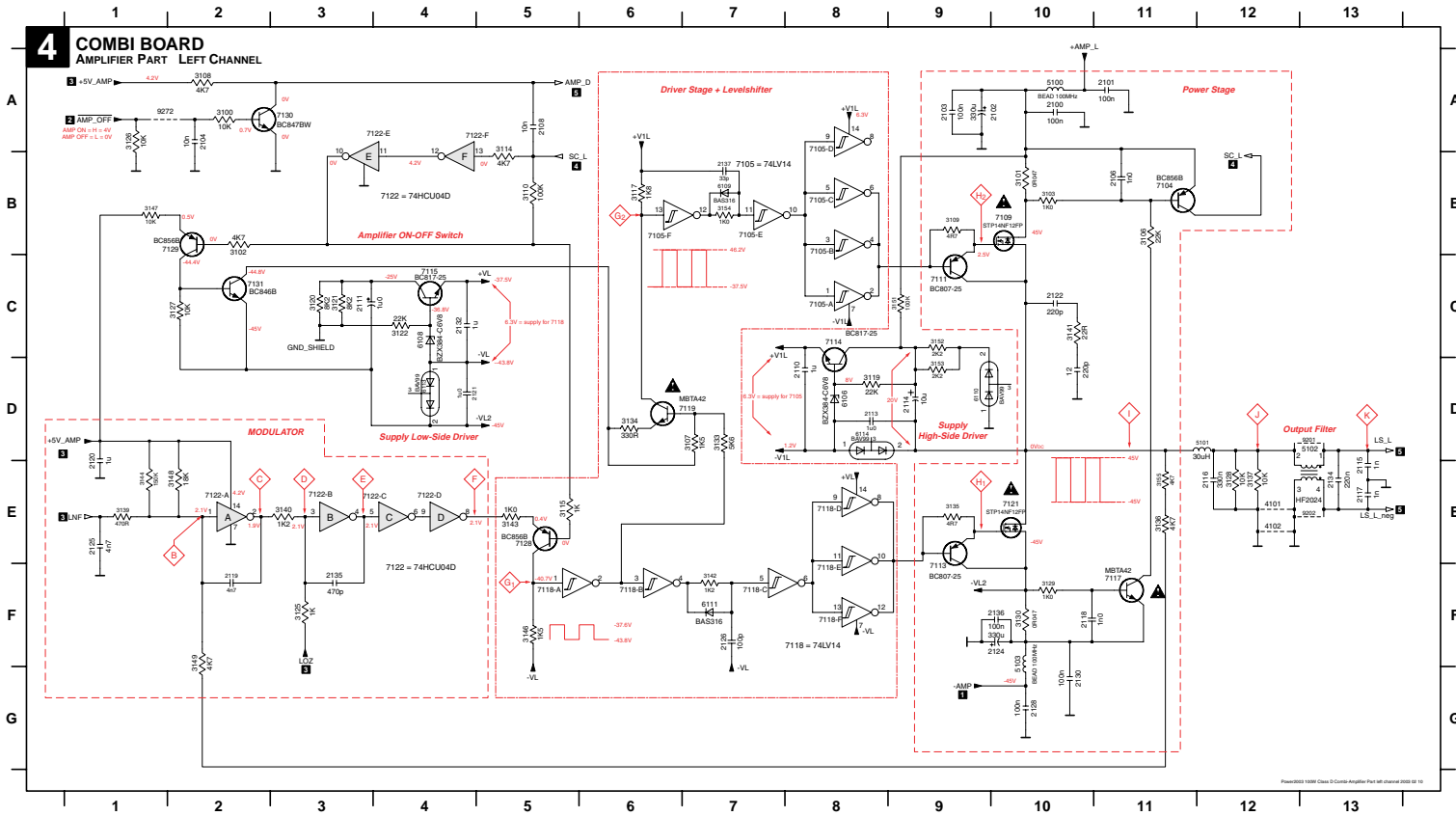

◇ for wave forms see chapter 11-4 Service Hints

1201 E14	2200 A10	2208 A4	2214 D8	2220 F10	2229 G9	2240 A6	3205 B9	3215 B9	3223 C12	3229 D13	3240 E11	3248 E10	3256 F5	3264 C8	4202 E11	6104 G12	6210 D8	6217 F6	7209-B B7	7211 B12	7227 F10	7232-D E4	7235-D E8	7243 G14
1211 D13	2201 A9	2209 C11	2215 D12	2221 F2	2234 D12	3112 F11	3207 A12	3216 B10	3224 C12	3230 C2	3241 F9	3251 E1	3258 G1	3266 C8	4201 A10	6202 B13	6211 C9	7110 F12	7209-C A7	7218 B9	7228 D6	7232-A A3	7235-E E8	8203 D12
1212 D13	2202 A11	2210 C7	2216 E11	2222 E1	2236 C4	3113 F12	3209 B9	3217 A4	3226 B6	3231 C3	3243 F9	3253 E2	3259 G1	3266 C8	4201 D11	6206 C13	6212 D9	7111 G12	7209-D B6	7225 C12	7231 E9	7232-F A4	7235-F F8	8204 E12
1307-A D14	2203 A8	2211 C3	2217 C9	2225 F9	2237 F3	3116 G12	3210 A4	3218 B2	3226 C11	3232 C3	3245 D6	3253 F6	3261 D6	3267 B6	4202 D12	6206 C13	6213 C4	7203 A13	7209-E B5	7221 C8	7232-A E1	7235-A F5	7238 B2	
1307-B E14	2205 A13	2213 D10	2218 F9	2226 E1	2238 D4	3201 A14	3211 E5	3219 C12	3227 B1	3238 E11	3246 D5	3254 F1	3262 F14	3268 D10	4201 G9	6208 D3	6214 B6	7208 B10	7209-F A7	7222 C8	7232-B E2	7235-B F5	7238 B2	
2109 F11	2206 B10	2213 G9	2219 E12	2227 F7	2239 D8	3203 A13	3213 F2	3221 C1	3228 D6	3239 C10	3247 E8	3255 E4	3263 G13	4201 E11	5205 C11	6209 C12	6216 F14	7209-A C7	7210 E9	7223 B4	7232-C E3	7235-C E7	7240 E5	

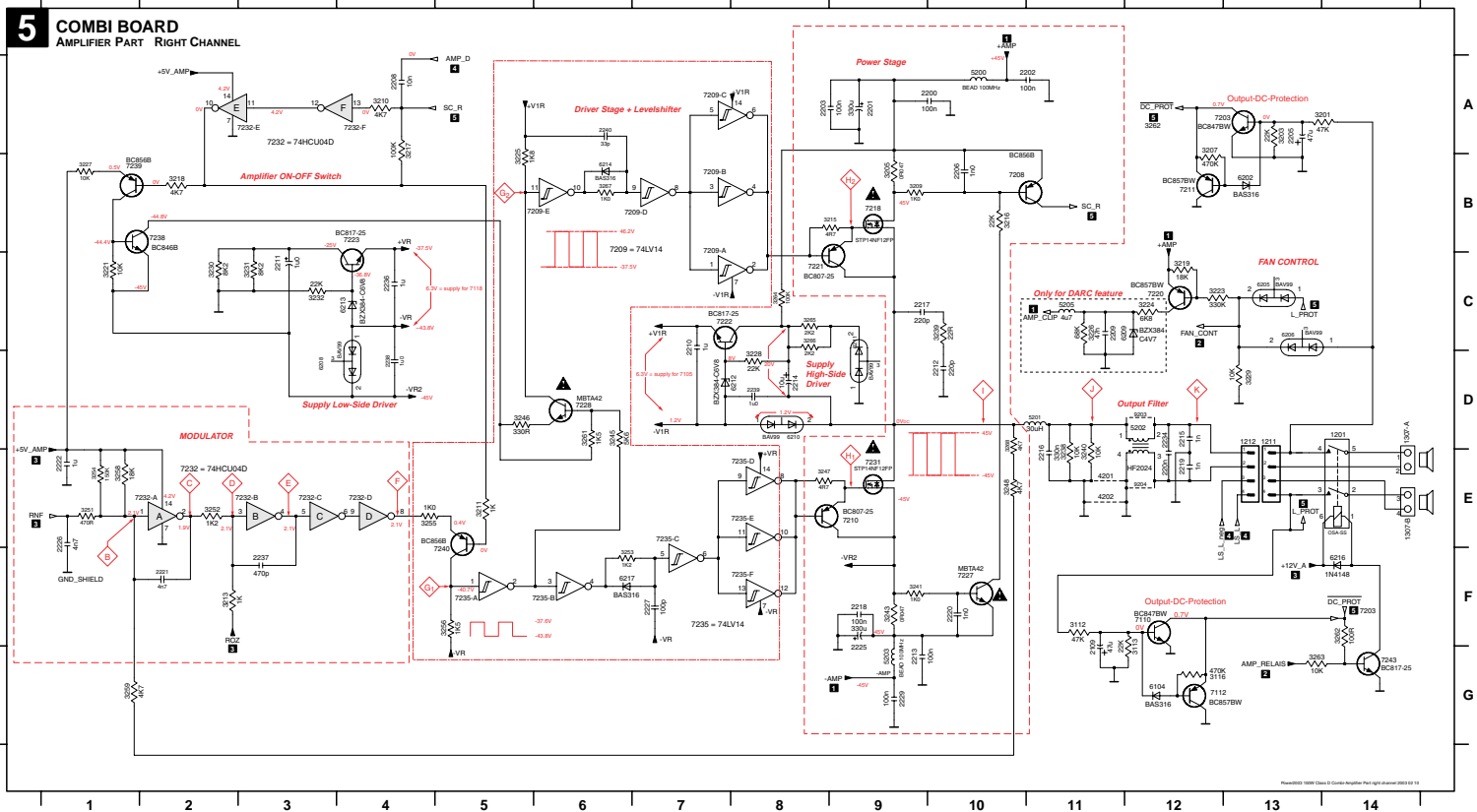

0201 D10	1207 B5	1222 A2	2204 A6	2210 C7	2215 D6	2220 E1	2226 D7	2233 A7	3204 A2	3212 D5	3219 E5	5001 A4	6201 C9	6209 C6	6215 D8	6221 E8	6226 E2	7203 D3	9201 B3
1201 A3	1208 C3	1223 A2	2205 A10	2211 C7	2216 E8	2222 D1	2228 C1	3200 A8	3205 B9	3213 D6	3220 E4	5002 E1	6202 A6	6210 C7	6216 D9	6222 E8	6227 B8	7204 E5	
1203 A5	1209 C5	2200 A6	2207 B8	2212 B7	2217 E9	2223 D6	2230 A7	3201 B8	3206 B2	3215 E3	3221 D6	5203 E1	6204 B9	6211 C3	6217 D2	6223 E3	6228 C1	7205 B2	
1205 A3	1210 C10	2201 C8	2208 B8	2213 D4	2218 E1	2224 E6	2231 B7	3202 A8	3207 C8	3217 C2	3222 E3	5204 D7	6206 C6	6212 C3	6219 D6	6224 C1	6229 C8	7206 D5	
1206 A3	1212 B5	2203 A6	2209 C6	2214 D1	2219 E7	2225 C8	2232 A7	3203 B9	3211 D4	3218 E1	3223 B8	6200 B8	6207 C7	6213 D2	6220 D8	6225 E2	7200 A9	9200 A3	

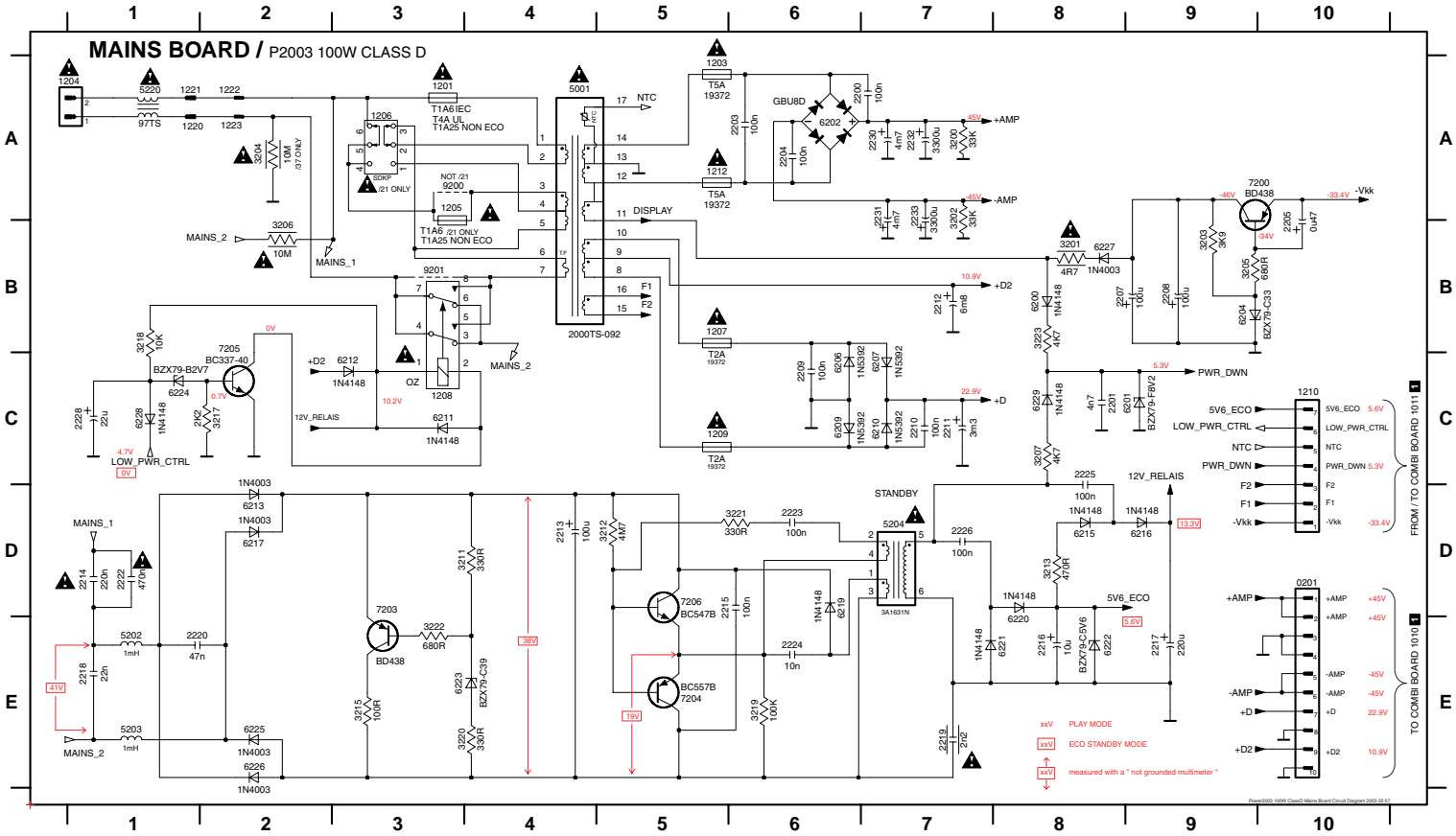

©2003 Philips North America Consumer Electronics Co. All rights reserved.

**ELECTRICAL PARTSLIST POWER 2003 100W Class-D MAINS BOARD****MISCELLANEOUS**

1201 ▲	4822 071 51602	FUSE 1,6A
1201 ▲	4822 253 10126	FUSE T4A
1203 ▲	4822 071 55002	FUSE T5A
1204 ▲	2422 030 00328	MAINS SOCKET /37
1204 ▲	4822 265 31015	MAINS SOCKET, IEC
1205 ▲	4822 071 51602	FUSE 1,6A
1206 ▲	2422 129 16478	VOLTAGE SELECTOR
1207 ▲	9965 000 07788	FUSE RAD T2A
1208 ▲	2422 132 07519	RELAY 1P 12V 16A
1209 ▲	9965 000 07788	FUSE RAD T2A
1210	4822 267 10953	FFC-CONNECTOR, 7P, TOP ENTRY
1212 ▲	4822 071 55002	FUSE T5A
5001 ▲	3103 308 30920	Mains Transformer /37
5001 ▲	3103 308 30910	Mains Transformer /22
5001 ▲	3103 308 30900	Mains Transformer /21, /21M

5204 ▲ 2422 549 45157 STANDBY TRANSFORMER

**CAPACITORS**

2200	4822 121 43696	100nF	10%	100V
2201	4822 122 31125	4,7nF	10%	63V
2203	4822 121 43696	100nF	10%	100V
2204	4822 121 43696	100nF	10%	100V
2205	5322 124 41948	0,47µF	20%	50V
2208	2020 012 93547	100µF	20%	63V
2209	5322 121 42386	100nF	5%	63V
2210	5322 121 42386	100nF	5%	63V
2211	4822 124 42367	3300µF	20%	35V
2212	4822 124 12328	6800µF	20%	16V
2213	4822 124 40255	100µF	20%	50V
2214 ▲	4822 121 10512	220nF	20%	275V
2215	5322 121 42386	100nF	5%	63V
2216	4822 124 21732	10µF	20%	25V
2217	4822 124 80144	220µF	20%	25V
2218	4822 121 41856	22nF	5%	250V
2219 ▲	4822 126 14088	2,2nF	20%	250V
2220	4822 121 43526	47nF	5%	100V
2222 ▲	4822 126 13589	470nF	10%	275V
2223	5322 121 42386	100nF	5%	63V
2224	4822 122 30043	10nF	80%	63V
2225	5322 121 42386	100nF	5%	63V
2226	5322 121 42386	100nF	5%	63V
2228 ©	4822 124 11946	22µF	20%	16V
2232	2022 020 00644	3300µF	20%	50V
2233	2022 020 00644	3300µF	20%	50V

**RESISTORS**

3200	4822 050 23303	33kΩ	1%	0,6W
3201 ▲	4822 052 10478	4,7Ω	5%	NFR25
3202	4822 050 23303	33kΩ	1%	0,6W
3203	4822 116 52276	3,9kΩ	5%	0,5W
3204 ▲	4822 053 21106	10MΩ	5%	0,5W
3205	4822 116 52228	680Ω	5%	0,5W
3206 ▲	4822 053 21106	10MΩ	5%	0,5W
3207	4822 116 52283	4,7kΩ	5%	0,5W
3211	4822 116 52219	330Ω	5%	0,5W
3212	4822 111 30893	4,7MΩ	5%	0,2W
3213	4822 116 83883	470Ω	5%	0,16W
3215	4822 116 52175	100Ω	5%	0,5W
3217	4822 116 52256	2,2kΩ	5%	0,16W
3218	4822 050 21003	10kΩ	2%	0,25W
3219	4822 116 52234	100kΩ	5%	0,5W
3220	4822 116 52219	330Ω	5%	0,5W
3221	4822 116 52219	330Ω	5%	0,5W
3222	4822 116 52228	680Ω	5%	0,5W
3223	4822 116 52283	4,7kΩ	5%	0,5W

**COILS**

5202	4822 157 53473	1000µH
5203	4822 157 53473	1000µH
5220 ▲	4822 157 11832	400µH Mains filter

**DIODES**

6200	4822 130 30621	1N4148
6201	4822 130 34382	BZX79-B8V2
6202	4822 130 11139	GBU8D
6204	4822 130 34142	BZX79-B33
6206	4822 130 31878	1N4003G
6207	4822 130 31878	1N4003G
6209	4822 130 31878	1N4003G
6210	4822 130 31878	1N4003G
6211	4822 130 30621	1N4148
6212	4822 130 30621	1N4148
6213	4822 130 31878	1N4003G
6215	4822 130 30621	1N4148
6216	4822 130 30621	1N4148
6217	4822 130 31878	1N4003G
6219	4822 130 30621	1N4148
6220	4822 130 31983	BAT85
6221	4822 130 31983	BAT85
6223	4822 130 34145	BZX79-B39
6224	5322 130 34563	BZX79-C2V7
6225	4822 130 31878	1N4003G
6226	4822 130 31878	1N4003G
6227	4822 130 31878	1N4003G
6228	4822 130 30621	1N4148
6229	4822 130 30621	1N4148

**TRANSISTORS**

7200	4822 130 40995	BD438
7203	4822 130 40995	BD438
7204	4822 130 44568	BC557B
7205	4822 130 40855	BC337-40
7206	4822 130 40959	BC547B

**ELECTRICAL PARTSLIST POWER 2003 100W Class-D COMBI BOARD****MECHANICAL PARTS**

0021 4822 492 11735 SPRING TRANSISTOR

**MISCELLANEOUS**

1005 2422 026 05418 SOCKET, CINCH, 2p  
 1011 4822 267 10953 FFC-CONNECTOR, 7P, TOP ENTRY  
 1012 2422 025 14518 FFC-CONNECTOR, 9P, TOP ENTRY  
 1013 4822 265 11515 FFC-CONNECTOR, 8P, TOP ENTRY  
 1014 4822 267 10733 FFC SOCKET, 4P

1018 4822 265 10981 FFC-CONNECTOR, 15P, TOP ENTRY  
 1022 4822 267 10953 FFC-CONNECTOR, 7P, TOP ENTRY  
 1026 4822 265 11553 FLEX FOIL CONNECTOR 19P  
 1201 2422 132 07517 RELAY 2P 12V  
 1307 2422 015 19893 SOCKET, CLICKFIT, 4P

**CAPACITORS**

2100© 4822 122 33496 100nF 10% 63V  
 2101© 2222 580 15649 100nF 10% 50V  
 2102 2020 012 93762 330µF 20% 50V  
 2103© 2222 580 15649 100nF 10% 50V  
 2104© 5322 126 11583 10nF 10% 63V

2106© 5322 126 11578 1nF 10% 63V  
 2108© 5322 126 11583 10nF 10% 63V  
 2109 4822 124 81286 47µF 20% 16V  
 2110© 3198 017 41050 1µF 20% 10V  
 2111 4822 124 22651 1µF 20% 50V

2112© 4822 122 33575 220pF 5% 50V  
 2113© 3198 017 41050 1µF 20% 10V  
 2114 4822 124 40248 10µF 20% 63V  
 2115© 5322 126 11578 1nF 10% 63V  
 2116 5322 121 42661 330nF 5% 63V

2117© 5322 126 11578 1nF 10% 63V  
 2118© 5322 126 11578 1nF 10% 63V  
 2119© 4822 126 13193 4,7nF 10% 63V  
 2120© 3198 017 41050 1µF 20% 10V  
 2121© 3198 017 41050 1µF 20% 10V

2122© 4822 122 33575 220pF 5% 50V  
 2124 2020 012 93762 330µF 20% 50V  
 2125© 4822 126 13193 4,7nF 10% 63V  
 2126© 2020 552 94427 100pF 5% 50V  
 2128© 2222 580 15649 100nF 10% 50V

2130© 2222 580 15649 100nF 10% 50V  
 2132© 3198 017 41050 1µF 20% 10V  
 2134 4822 121 42408 220nF 5% 63V  
 2135© 4822 126 13881 470pF 5% 50V  
 2136© 2222 580 15649 100nF 10% 50V

2137© 2222 867 15339 33pF 5% 50V  
 2200© 2222 580 15649 100nF 10% 50V  
 2201 2020 012 93762 330µF 20% 50V  
 2202© 2222 580 15649 100nF 10% 50V  
 2203© 2222 580 15649 100nF 10% 50V

2205 4822 124 81286 47µF 20% 16V  
 2206© 5322 126 11578 1nF 10% 63V  
 2208© 5322 126 11583 10nF 10% 63V  
 2210© 3198 017 41050 1µF 20% 10V  
 2211 4822 124 22651 1µF 20% 50V

2212© 4822 122 33575 220pF 5% 50V  
 2213© 2222 580 15649 100nF 10% 50V  
 2214 4822 124 40248 10µF 20% 63V  
 2215© 5322 126 11578 1nF 10% 63V  
 2216 5322 121 42661 330nF 5% 63V

2217© 4822 122 33575 220pF 5% 50V  
 2218© 2222 580 15649 100nF 10% 50V

**CAPACITORS**

2219© 5322 126 11578 1nF 10% 63V  
 2220© 5322 126 11578 1nF 10% 63V  
 2221© 4822 126 13193 4,7nF 10% 63V  
 2222© 3198 017 41050 1µF 20% 10V  
 2224 4822 124 81151 22µF 20% 50V

2225 2020 012 93762 330µF 20% 50V  
 2226© 4822 126 13193 4,7nF 10% 63V  
 2227© 2020 552 94427 100pF 5% 50V  
 2229© 2222 580 15649 100nF 10% 50V  
 2234 4822 121 42408 220nF 5% 63V

2236© 3198 017 41050 1µF 20% 10V  
 2237© 4822 126 13881 470pF 5% 50V  
 2238© 3198 017 41050 1µF 20% 10V  
 2239© 3198 017 41050 1µF 20% 10V  
 2240© 2222 867 15339 33pF 5% 50V

2300© 4822 126 13883 220pF 5% 50V  
 2301© 4822 126 13883 220pF 5% 50V  
 2303© 4822 126 13881 470pF 5% 50V  
 2304 4822 124 81286 47µF 20% 16V  
 2305© 3198 017 41050 1µF 20% 10V

2306© 4822 126 14585 100nF 10% 50V  
 2309 4822 124 11947 10µF 20% 16V  
 2312© 2222 580 15649 100nF 10% 50V  
 2313© 3198 016 31020 1nF 5% 25V  
 2314© 4822 126 13883 220pF 5% 50V

2316© 4822 126 14585 100nF 10% 50V  
 2317 4822 124 21732 10µF 20% 25V  
 2318© 4822 126 13881 470pF 5% 50V  
 2319© 4822 126 14585 100nF 10% 50V  
 2320© 4822 126 14585 100nF 10% 50V

2321 4822 124 81286 47µF 20% 16V  
 2322© 4822 126 14585 100nF 10% 50V  
 2324 4822 124 22726 4,7µF 20% 35V  
 2325© 4822 126 13881 470pF 5% 50V  
 2326© 2020 552 94427 100pF 5% 50V

2327© 2020 552 94427 100pF 5% 50V  
 2328 4822 124 81151 22µF 20% 50V  
 2329 4822 124 22726 4,7µF 20% 35V  
 2330 4822 124 81151 22µF 20% 50V  
 2331 4822 124 22726 4,7µF 20% 35V

2332© 2020 552 94427 100pF 5% 50V  
 2333© 2020 552 94427 100pF 5% 50V  
 2334© 2222 867 15339 33pF 5% 50V  
 2335© 2238 586 59812 100nF 10% 50V  
 2336© 2238 586 59812 100nF 10% 50V

2337 4822 124 21732 10µF 20% 25V  
 2339© 3198 017 41050 1µF 20% 10V  
 2400© 2020 552 94427 100pF 5% 50V  
 2401© 4822 126 13881 470pF 5% 50V  
 2402 4822 124 23052 100µF 20% 16V

2403 4822 124 22651 1µF 20% 50V  
 2404© 2020 552 94427 100pF 5% 50V  
 2405 4822 124 12032 4,7µF 20% 50V  
 2406 4822 124 80791 470µF 20% 16V  
 2407© 2020 552 94427 100pF 5% 50V

2408 4822 124 22651 1µF 20% 50V  
 2409© 4822 126 13881 470pF 5% 50V  
 2410 4822 124 23052 100µF 20% 16V  
 2411© 2020 552 94427 100pF 5% 50V  
 2415© 3198 017 41050 1µF 20% 10V

2416 4822 124 23052 100µF 20% 16V  
 2417© 3198 017 41050 1µF 20% 10V



**ELECTRICAL PARTSLIST POWER 2003 100W Class-D COMBI BOARD****CAPACITORS**

2418	©	2020 552 94427	100pF	5%	50V
2419	©	2020 552 94427	100pF	5%	50V
2420	©	3198 017 41050	1µF	20%	10V
2421	©	2238 586 59812	100nF	10%	50V
2500		2022 020 00734	1µF	20%	50V
2519	©	2238 586 59812	100nF	10%	50V
2520	©	4822 126 13881	470pF	5%	50V
2528		2022 020 00734	1µF	20%	50V
2531	©	4822 126 13881	470pF	5%	50V
2534		4822 124 40769	4,7µF	20%	100V
2535		4822 124 40769	4,7µF	20%	100V
2536	©	2238 586 59812	100nF	10%	50V
2537		2022 020 00734	1µF	20%	50V
2540		2022 020 00734	1µF	20%	50V
2541		4822 124 81151	22µF	20%	50V
2542	©	3198 016 31020	1nF	5%	25V
2543	©	2020 552 96684	470nF	10%	25V
2546	©	4822 126 14549	33nF	10%	16V
2548	©	2020 552 96327	330nF	10%	16V
2549	©	2020 552 96684	470nF	10%	25V
2550	©	5322 126 11579	3,3nF	10%	63V
2551	©	4822 126 13879	220nF	20%	16V
2552	©	4822 126 13193	4,7nF	10%	63V
2553		4822 124 22651	1µF	20%	50V
2555		4822 124 81286	47µF	20%	16V
2556		4822 124 22651	1µF	20%	50V
2557		2022 020 00734	1µF	20%	50V
2558	©	2020 552 96684	470nF	10%	25V
2559		2022 020 00734	1µF	20%	50V
2560	©	4822 126 13881	470pF	5%	50V
2561	©	4822 126 13881	470pF	5%	50V
2562	©	4822 126 13881	470pF	5%	50V
2563	©	4822 126 13881	470pF	5%	50V
2564	©	4822 126 13881	470pF	5%	50V
2565	©	4822 126 13881	470pF	5%	50V
2566	©	4822 126 13881	470pF	5%	50V
2567	©	4822 126 13881	470pF	5%	50V
2568		4822 124 12233	47µF	20%	25V
2569	©	2020 552 96684	470nF	10%	25V
2570	©	2020 552 94427	100pF	5%	50V
2571	©	2020 552 94427	100pF	5%	50V
2572	©	4822 126 13879	220nF	20%	16V
2573	©	2020 552 96684	470nF	10%	25V
2574	©	4822 126 13193	4,7nF	10%	63V
2575	©	2020 552 96327	330nF	10%	16V
2576	©	3198 016 31020	1nF	5%	25V
2577	©	4822 126 14549	33nF	10%	16V
2578	©	5322 126 11579	3,3nF	10%	63V
2580		4822 124 81151	22µF	20%	50V
2581		4822 124 22651	1µF	20%	50V

**RESISTORS**

3100		4822 050 21003	10kΩ	2%	0,25W
3101	©	2122 118 06235	CHIP JUMPER 2512		
3102	©	4822 051 30472	4,7kΩ	5%	0,06W
3103	©	4822 051 30102	1kΩ	5%	0,06W
3106	©	4822 051 30223	22kΩ	5%	0,06W
3107	©	4822 051 30152	1,5kΩ	5%	0,06W
3108	©	4822 051 30472	4,7kΩ	5%	0,06W
3109	©	4822 117 13608	4,7Ω	5%	0,06W
3110	©	4822 117 13632	100kΩ	1%	0,06W

**RESISTORS**

3111	©	4822 051 30682	6,8kΩ	5%	0,06W
3112	©	4822 117 12925	47kΩ	1%	0,06W
3113	©	4822 051 30223	22kΩ	5%	0,06W
3114	©	4822 051 30472	4,7kΩ	5%	0,06W
3115	©	4822 051 30102	1kΩ	5%	0,06W
3116	©	4822 051 30474	470kΩ	5%	0,06W
3117	©	4822 117 12903	1,8kΩ	1%	0,06W
3118	©	4822 051 30682	6,8kΩ	5%	0,06W
3119	©	4822 051 30103	10kΩ	5%	0,06W
3120	©	4822 117 12902	8,2kΩ	1%	0,06W
3121	©	4822 117 12902	8,2kΩ	1%	0,06W
3122	©	4822 051 30223	22kΩ	5%	0,06W
3123	©	4822 051 30472	4,7kΩ	5%	0,06W
3124	©	4822 051 30472	4,7kΩ	5%	0,06W
3125	©	4822 051 30102	1kΩ	5%	0,06W
3126	©	4822 051 30103	10kΩ	5%	0,06W
3127	©	4822 051 30103	10kΩ	5%	0,06W
3128	©	4822 051 30103	10kΩ	5%	0,06W
3129	©	4822 051 30102	1kΩ	5%	0,06W
3130	©	2122 118 06235	CHIP JUMPER 2512		
3131	©	4822 051 30222	2,2kΩ	5%	0,06W
3132	©	4822 051 30222	2,2kΩ	5%	0,06W
3133	©	4822 051 30562	5,6kΩ	5%	0,06W
3134	©	4822 051 30331	330Ω	5%	0,06W
3135	©	4822 117 13608	4,7Ω	5%	0,06W
3136	©	4822 051 30472	4,7kΩ	5%	0,06W
3137	©	4822 051 30103	10kΩ	5%	0,06W
3139		4822 116 83883	470Ω	5%	0,16W
3140	©	4822 117 11817	1,2kΩ	1%	0,06W
3141	©	4822 117 12139	22Ω	5%	0,06W
3142	©	4822 117 11817	1,2kΩ	1%	0,06W
3143	©	4822 051 30102	1kΩ	5%	0,06W
3144	©	4822 051 30154	150kΩ	5%	0,06W
3146	©	4822 051 30152	1,5kΩ	5%	0,06W
3147	©	4822 051 30103	10kΩ	5%	0,06W
3148	©	4822 051 30183	18kΩ	5%	0,06W
3149	©	4822 051 30472	4,7kΩ	5%	0,06W
3151	©	4822 117 13632	100kΩ	1%	0,06W
3152	©	4822 051 30222	2,2kΩ	5%	0,06W
3153	©	4822 051 30222	2,2kΩ	5%	0,06W
3154	©	4822 051 30102	1kΩ	5%	0,06W
3155	©	4822 051 30472	4,7kΩ	5%	0,06W
3201	©	4822 117 12925	47kΩ	1%	0,06W
3203	©	4822 051 30223	22kΩ	5%	0,06W
3205	©	2122 118 06235	CHIP JUMPER 2512		
3207	©	4822 051 30474	470kΩ	5%	0,06W
3209	©	4822 051 30102	1kΩ	5%	0,06W
3210	©	4822 051 30472	4,7kΩ	5%	0,06W
3211	©	4822 051 30102	1kΩ	5%	0,06W
3213	©	4822 051 30102	1kΩ	5%	0,06W
3215	©	4822 117 13608	4,7Ω	5%	0,06W
3216	©	4822 051 30223	22kΩ	5%	0,06W
3217	©	4822 117 13632	100kΩ	1%	0,06W
3218	©	4822 051 30472	4,7kΩ	5%	0,06W
3221	©	4822 051 30103	10kΩ	5%	0,06W
3225	©	4822 117 12903	1,8kΩ	1%	0,06W
3227	©	4822 051 30103	10kΩ	5%	0,06W
3228	©	4822 051 30103	10kΩ	5%	0,06W
3229	©	4822 051 30103	10kΩ	5%	0,06W
3230	©	4822 117 12902	8,2kΩ	1%	0,06W
3231	©	4822 117 12902	8,2kΩ	1%	0,06W
3232	©	4822 051 30223	22kΩ	5%	0,06W

**ELECTRICAL PARTSLIST POWER 2003 100W Class-D COMBI BOARD**

## RESISTORS

3238	4822 051 30103	10kΩ	5%	0,06W
3239	4822 117 12139	22Ω	5%	0,06W
3240	4822 051 30103	10kΩ	5%	0,06W
3241	4822 051 30102	1kΩ	5%	0,06W
3243	2122 118 06235	CHIP JUMPER	2512	
3245	4822 051 30562	5,6kΩ	5%	0,06W
3246	4822 051 30331	330Ω	5%	0,06W
3247	4822 117 13608	4,7Ω	5%	0,06W
3248	4822 051 30472	4,7kΩ	5%	0,06W
3251	4822 116 83883	470Ω	5%	0,16W
3252	4822 117 11817	1,2kΩ	1%	0,06W
3253	4822 117 11817	1,2kΩ	1%	0,06W
3254	4822 051 30154	150kΩ	5%	0,06W
3255	4822 051 30102	1kΩ	5%	0,06W
3256	4822 051 30152	1,5kΩ	5%	0,06W
3258	4822 051 30183	18kΩ	5%	0,06W
3259	4822 051 30472	4,7kΩ	5%	0,06W
3261	4822 051 30152	1,5kΩ	5%	0,06W
3262	4822 051 30101	100Ω	5%	0,06W
3263	4822 051 30103	10kΩ	5%	0,06W
3264	4822 117 13632	100kΩ	1%	0,06W
3265	4822 051 30222	2,2kΩ	5%	0,06W
3266	4822 051 30222	2,2kΩ	5%	0,06W
3267	4822 051 30102	1kΩ	5%	0,06W
3268	4822 051 30472	4,7kΩ	5%	0,06W
3302	4822 117 13632	100kΩ	1%	0,06W
3303	4822 051 30103	10kΩ	5%	0,06W
3304	4822 116 52186	22Ω	5%	0,5W
3305	4822 051 30682	6,8kΩ	5%	0,06W
3306	4822 101 11778	Potmeter	47kΩ	0,1W
3307	4822 101 11778	Potmeter	47kΩ	0,1W
3311	4822 051 30103	10kΩ	5%	0,06W
3312	4822 117 13632	100kΩ	1%	0,06W
3313	4822 051 30221	220Ω	5%	0,06W
3314	4822 117 12925	47kΩ	1%	0,06W
3315	4822 050 11002	1kΩ	5%	0,2W
3316	4822 051 30273	27kΩ	5%	0,06W
3317	4822 051 30333	33kΩ	5%	0,06W
3318	4822 117 13632	100kΩ	1%	0,06W
3319	4822 051 30222	2,2kΩ	5%	0,06W
3320	4822 051 30103	10kΩ	5%	0,06W
3321	4822 051 30102	1kΩ	5%	0,06W
3322	4822 051 30103	10kΩ	5%	0,06W
3323	4822 117 12968	820Ω	5%	0,06W
3324	4822 051 30105	1MΩ	5%	0,06W
3325	4822 051 30154	150kΩ	5%	0,06W
3326	4822 051 30154	150kΩ	5%	0,06W
3327	4822 052 10339	33Ω	5%	NFR
3328	4822 117 12902	8,2kΩ	1%	0,06W
3329	4822 116 52256	2,2kΩ	5%	0,16W
3330	4822 051 30103	10kΩ	5%	0,06W
3331	4822 051 30103	10kΩ	5%	0,06W
3332	4822 051 30332	3,3kΩ	5%	0,06W
3334	4822 051 30102	1kΩ	5%	0,06W
3336	4822 051 30123	12kΩ	5%	0,06W
3337	4822 051 30471	470Ω	5%	0,06W
3338	4822 051 30102	1kΩ	5%	0,06W
3339	4822 051 30222	2,2kΩ	5%	0,06W
3340	4822 051 30471	470Ω	5%	0,06W
3341	4822 051 30682	6,8kΩ	5%	0,06W
3342	4822 051 30121	120Ω	5%	0,06W
3343	4822 051 30151	150Ω	5%	0,06W

## RESISTORS

3344	4822 051 30471	470Ω	5%	0,06W
3345	4822 051 30471	470Ω	5%	0,06W
3346	4822 051 30479	47Ω	5%	0,06W
3400	4822 051 30273	27kΩ	5%	0,06W
3401	4822 051 30471	470Ω	5%	0,06W
3403	4822 051 30273	27kΩ	5%	0,06W
3404	4822 051 30682	6,8kΩ	5%	0,06W
3405	4822 051 30472	4,7kΩ	5%	0,06W
3406	4822 052 10109	10Ω	5%	NFR
3407	4822 051 30472	4,7kΩ	5%	0,06W
3408	4822 051 30682	6,8kΩ	5%	0,06W
3409	4822 051 30273	27kΩ	5%	0,06W
3411	4822 116 52283	4,7kΩ	5%	0,5W
3412	4822 052 10568	5,6Ω	5%	0,33W
3413	4822 051 30471	470Ω	5%	0,06W
3415	4822 051 30273	27kΩ	5%	0,06W
3422	4822 051 30472	4,7kΩ	5%	0,06W
3423	4822 051 30103	10kΩ	5%	0,06W
3424	4822 051 30103	10kΩ	5%	0,06W
3425	2120 108 91909	39Ω	5%	
3426	2120 108 91909	39Ω	5%	
3427	4822 051 30103	10kΩ	5%	0,06W
3428	4822 051 30103	10kΩ	5%	0,06W
3429	2120 108 91909	39Ω	5%	
3430	2120 108 91909	39Ω	5%	
3431	4822 051 30562	5,6kΩ	5%	0,06W
3432	4822 051 30102	1kΩ	5%	0,06W
3433	4822 051 30102	1kΩ	5%	0,06W
3434	4822 051 30222	2,2kΩ	5%	0,06W
3435	4822 051 30271	270Ω	5%	0,06W
3436	4822 051 30472	4,7kΩ	5%	0,06W
3437	4822 051 30562	5,6kΩ	5%	0,06W
3438	4822 051 30103	10kΩ	5%	0,06W
3439	4822 051 30103	10kΩ	5%	0,06W
3440	4822 116 81154	2,2Ω	5%	0,5W
3500	4822 051 30152	1,5kΩ	5%	0,06W
3504	4822 051 30103	10kΩ	5%	0,06W
3506	4822 051 30471	470Ω	5%	0,06W
3507	4822 117 12902	8,2kΩ	1%	0,06W
3514	4822 051 30153	15kΩ	5%	0,06W
3518	4822 051 30152	1,5kΩ	5%	0,06W
3519	4822 051 30103	10kΩ	5%	0,06W
3520	4822 051 30153	15kΩ	5%	0,06W
3522	4822 051 30152	1,5kΩ	5%	0,06W
3523	4822 051 30152	1,5kΩ	5%	0,06W
3524	4822 117 11817	1,2kΩ	1%	0,06W
3525	4822 051 30273	27kΩ	5%	0,06W
3526	4822 051 30334	330kΩ	5%	0,06W
3527	4822 051 30273	27kΩ	5%	0,06W
3529	4822 051 30154	150kΩ	5%	0,06W
3531	4822 051 30154	150kΩ	5%	0,06W
3532	4822 117 12864	82kΩ	5%	0,06W
3534	4822 052 10109	10Ω	5%	NFR
3535	4822 051 30562	5,6kΩ	5%	0,06W
3536	4822 051 30223	22kΩ	5%	0,06W
3539	4822 051 30153	15kΩ	5%	0,06W
3542	4822 051 30123	12kΩ	5%	0,06W
3543	4822 117 12902	8,2kΩ	1%	0,06W
3544	4822 051 30562	5,6kΩ	5%	0,06W
3545	4822 051 30393	39kΩ	5%	0,06W
3549	4822 051 30101	100Ω	5%	0,06W
3550	4822 051 30393	39kΩ	5%	0,06W

**ELECTRICAL PARTSLIST POWER 2003 100W Class-D COMBI BOARD****RESISTORS**

3551 ©	4822 051 30101	100Ω	5%	0,06W
3552 ©	4822 051 30101	100Ω	5%	0,06W
3553 ©	4822 051 30101	100Ω	5%	0,06W
3554 ©	4822 051 30101	100Ω	5%	0,06W
3555 ©	4822 051 30472	4,7kΩ	5%	0,06W
3556 ©	4822 051 30123	12kΩ	5%	0,06W
3557 ©	4822 051 30101	100Ω	5%	0,06W
3558 ©	4822 117 12903	1,8kΩ	1%	0,06W
3559 ©	4822 117 12903	1,8kΩ	1%	0,06W
3560 ©	4822 051 30101	100Ω	5%	0,06W
3561 ©	4822 051 30102	1kΩ	5%	0,06W
3562 ©	4822 051 30102	1kΩ	5%	0,06W
3563 ©	4822 051 30101	100Ω	5%	0,06W
3564 ©	4822 051 30101	100Ω	5%	0,06W
3566 ©	4822 051 30101	100Ω	5%	0,06W
3567 ©	4822 051 30332	3,3kΩ	5%	0,06W
3568 ©	4822 051 30101	100Ω	5%	0,06W
3569 ©	4822 051 30102	1kΩ	5%	0,06W
3570 ©	4822 117 13632	100kΩ	1%	0,06W
3571 ©	4822 051 30223	22kΩ	5%	0,06W
3572	4822 116 83883	470Ω	5%	0,16W
3573	4822 116 83883	470Ω	5%	0,16W
3574 ©	4822 051 30101	100Ω	5%	0,06W
3575 ©	4822 051 30562	5,6kΩ	5%	0,06W
3576 ©	4822 051 30123	12kΩ	5%	0,06W
3577 ©	4822 051 30153	15kΩ	5%	0,06W
3578 ©	4822 117 12902	8,2kΩ	1%	0,06W
3579 ©	4822 051 30562	5,6kΩ	5%	0,06W
3580 ©	4822 051 30472	4,7kΩ	5%	0,06W
4101 ©	4822 051 20008	CHIP JUMPER	0805	
4102 ©	4822 051 20008	CHIP JUMPER	0805	
4201 ©	4822 051 20008	CHIP JUMPER	0805	
4202 ©	4822 051 20008	CHIP JUMPER	0805	
4211 ©	4822 051 20008	CHIP JUMPER	0805	
4212 ©	4822 051 20008	CHIP JUMPER	0805	
4213 ©	4822 051 30008	CHIP JUMPER	0603	
4214 ©	4822 051 20008	CHIP JUMPER	0805	
4215 ©	4822 051 30008	CHIP JUMPER	0603	
4216 ©	4822 051 30008	CHIP JUMPER	0603	
4217 ©	4822 051 30008	CHIP JUMPER	0603	
4221 ©	4822 051 30008	CHIP JUMPER	0603	
4223 ©	4822 051 30008	CHIP JUMPER	0603	
4226 ©	4822 051 30008	CHIP JUMPER	0603	
4230 ©	4822 051 30008	CHIP JUMPER	0603	
4232 ©	4822 051 30008	CHIP JUMPER	0603	
4233 ©	4822 051 30008	CHIP JUMPER	0603	
4235 ©	4822 051 30008	CHIP JUMPER	0603	
4240 ©	4822 051 20008	CHIP JUMPER	0805	
4241 ©	4822 051 20008	CHIP JUMPER	0805	
4242 ©	4822 051 30008	CHIP JUMPER	0603	
4243 ©	4822 051 30008	CHIP JUMPER	0603	
4245 ©	4822 051 30008	CHIP JUMPER	0603	
4253 ©	4822 051 30008	CHIP JUMPER	0603	
4260 ©	4822 051 20008	CHIP JUMPER	0805	
4265 ©	4822 051 30008	CHIP JUMPER	0603	
4272 ©	4822 051 30008	CHIP JUMPER	0603	
4273 ©	4822 051 30008	CHIP JUMPER	0603	
4274 ©	4822 051 20008	CHIP JUMPER	0805	
4276 ©	4822 051 30008	CHIP JUMPER	0603	
4277 ©	4822 051 30008	CHIP JUMPER	0603	
4279 ©	4822 051 30008	CHIP JUMPER	0603	
4301 ©	4822 051 30008	CHIP JUMPER	0603	

**COILS**

5100	4822 526 10494	FERRITE BEAD
5101	2422 536 00612	30μH
5102	2422 549 44944	Mains Filter 330μH 3A
5103	4822 526 10494	FERRITE BEAD
5104	4822 526 10494	FERRITE BEAD
5200	4822 526 10494	FERRITE BEAD
5201	2422 536 00612	30μH
5202	2422 549 44944	Mains Filter 330μH 3A
5203	4822 526 10494	FERRITE BEAD
5300	2422 540 98542	Resonator 500kHz
5302	2422 540 98561	Resonator 425kHz

**DIODES**

6104 ©	4822 130 11397	BAS316
6105 ©	4822 130 11397	BAS316
6106 ©	4822 130 11416	PDZ6.8B
6108 ©	4822 130 11416	PDZ6.8B
6109 ©	4822 130 11397	BAS316
6110 ©	5322 130 34337	BAV99
6111 ©	4822 130 11397	BAS316
6113 ©	5322 130 34337	BAV99
6114 ©	5322 130 34337	BAV99
6202 ©	4822 130 11397	BAS316
6205 ©	5322 130 34337	BAV99
6206 ©	5322 130 34337	BAV99
6208 ©	5322 130 34337	BAV99
6210 ©	5322 130 34337	BAV99
6211 ©	5322 130 34337	BAV99
6212 ©	4822 130 11416	PDZ6.8B
6213 ©	4822 130 11416	PDZ6.8B
6214 ©	4822 130 11397	BAS316
6216	4822 130 30621	1N4148
6217 ©	4822 130 11397	BAS316
6300 ©	4822 130 10838	UDZ3.3B
6401	4822 130 30621	1N4148
6403 ©	4822 130 10838	UDZ3.3B
6501 ©	9322 102 64685	UDZ-2,7B
6502 ©	4822 130 11397	BAS316
6503 ©	4822 130 11397	BAS316
6504 ©	4822 130 11397	BAS316
6505 ©	4822 130 11397	BAS316
6506 ©	9322 150 18685	BZX384-C47
6507 ©	9322 150 18685	BZX384-C47
6508 ©	3198 020 55680	BZX384-C5V6
<b>TRANSISTORS</b>		
7104 ©	4822 130 60373	BC856B
7109 ▲	9322 173 29687	STP14NF12FP Power FET
7110 ©	3198 010 42310	BC847BW
7111 ©	3198 010 44350	BC807-25W
7112 ©	3198 010 42320	BC857BW
7113 ©	3198 010 44350	BC807-25W
7114 ©	9340 219 30115	BC817-25W
7115 ©	9340 219 30115	BC817-25W
7117 ©▲	9322 043 49685	MMBTA42
7119 ©	9322 043 49685	MMBTA42
7121 ▲	9322 173 29687	STP14NF12FP Power FET
7128 ©	4822 130 60373	BC856B
7129 ©	4822 130 60373	BC856B
7130 ©	3198 010 42310	BC847BW
7131 ©	5322 130 60159	BC846B

**ELECTRICAL PARTSLIST POWER 2003 100W Class-D COMBI BOARD**

---

TRANSISTORS

---

7203© 3198 010 42310 BC847BW  
 7208© 4822 130 60373 BC856B  
 7210© 3198 010 44350 BC807-25W  
 7211© 3198 010 42320 BC857BW  
 7218▲ 9322 173 29687 STP14NF12FP Power FET

7221© 3198 010 44350 BC807-25W  
 7222© 9340 219 30115 BC817-25W  
 7223© 9340 219 30115 BC817-25W  
 7227©▲ 9322 043 49685 MMBTA42  
 7228©▲ 9322 043 49685 MMBTA42

7231▲ 9322 173 29687 STP14NF12FP Power FET  
 7238© 5322 130 60159 BC846B  
 7239© 4822 130 60373 BC856B  
 7240© 4822 130 60373 BC856B  
 7243© 9340 219 30115 BC817-25W

7309© 3198 010 42310 BC847BW  
 7316© 3198 010 42320 BC857BW  
 7317© 3198 010 42310 BC847BW  
 7319© 3198 010 42310 BC847BW  
 7323© 9340 219 30115 BC817-25W

7324© 9340 219 30115 BC817-25W  
 7402 4822 130 40855 BC337-40  
 7405© 3198 010 42320 BC857BW  
 7407© 9340 219 30115 BC817-25W  
 7408© 9340 219 30115 BC817-25W

7409© 9340 219 30115 BC817-25W  
 7410© 3198 010 42320 BC857BW  
 7411© 3198 010 44350 BC807-25W  
 7505© 3198 010 42310 BC847BW  
 7506© 3198 010 42320 BC857BW

7509© 3198 010 42310 BC847BW

INTEGRATED CIRCUITS

---

7105© 9350 694 90118 74LV14D  
 7118© 9350 694 90118 74LV14D  
 7122© 5322 209 11517 PC74HCU04T, HEX INVERTER IC  
 7209© 9350 694 90118 74LV14D  
 7232© 5322 209 11517 PC74HCU04T, HEX INVERTER IC

7235© 9350 694 90118 74LV14D  
 7310 4822 209 14933 TL431IZ, PROGRAMMABLE VOLT. REF.  
 7312© 5322 209 11517 PC74HCU04T, HEX INVERTER IC  
 7315 4822 209 81351 LM317MPTB  
 7320© 4822 209 83357 NJM4560M

7321 4822 209 81351 LM317MPTB  
 7400© 4822 209 31378 NJM4556M, 2-FOLD OP-AMP.  
 7406© 4822 209 17345 M62320FP, I2C SHIFT REGISTER  
 7508© 9322 150 74668 TDA7468D, SOURCE SEL. & SOUND