

# Parts Catalog

## 適応

本サービスマニュアルのデータは、該当製品のサービスを行う技術者が修理を行うためのツールとして、キヤノン株式会社が発行しています。本サービスマニュアルのデータは、該当製品が販売される地域に対応する内容で作成されているため、貴地域に非該当の製品の情報が記載されている場合があります。下記の内容は本サービスマニュアルおよび製品が使用される国の法律及び各例に合致しない場合には、適用されません。

## 情報改訂

本サービスマニュアルには、該当製品の改良変更のため、技術的に不正確な記述、あるいはミスプリントが含まれることがあります。これらの理由により、本サービスマニュアルの内容に変更が発生した場合には、発行元の判断によりサービスインフォメーションを発行します。また、本サービスマニュアルの内容に大幅な変更が生じた場合には、発行元の判断により改訂版を発行します。

## 商標

本サービスマニュアルに記載されている各製品名、各会社名は各社の登録商標です。

## 著作権

本サービスマニュアルの著作権は、キヤノン株式会社に帰属しています。キヤノン株式会社の書面による同意の無い場合には本サービスマニュアルの一部あるいは、全体を複製・閲覧（web等を含む）・転載・加工（変更）・他の言語への翻訳等が禁止されています。

Copyright © 2011 Canon Inc.

キヤノン株式会社

カメラレンズサービス・品質保証課

〒146-8501 東京都大田区下丸子 3-30-2

2011年2月発行

# Canon

## K286

REF. NO. **C12-6311**  
**C12-6313**  
**C12-6315**

# PARTS CATALOG

## Application

This Service Manual is issued by Canon Inc. for qualified persons to learn technical theory and product repair. This Service Manual covers all localities where the products are sold. For this reason, there may be information in this Service Manual that does not apply to the product sold in your locality. The following paragraph does not apply to any countries where such provisions are inconsistent with local law.

## Information revision

This Service Manual could include typographical errors or technical inaccuracies due to improvements or changes in the products. For this reason, when changes occur in the content of this Service Manual, Canon will release service information as the need arises. In the event of major changes in the content of this Service Manual, Canon may issue new editions of this Service Manual at its discretion.

## Trademarks

The product names and company names described in this Service Manual are the registered trademarks of the individual companies.

## Copyright

Canon Inc. retains the copyright to this Service Manual. Reproduction, publication (including on the World Wide Web), alteration, translation into another language, or other use of the data in whole or part, contained on this Service Manual without the written consent of Canon Inc. is prohibited.

Copyright © 2011 Canon Inc.

Canon Inc.

Camera-Lens Products Service & Quality Assurance Dept.

30-2, Shimomaruko 3-Chome, Ohta-ku, Tokyo 146-8501, Japan

First published February, 2011

Copyright © 2011 Canon Inc.

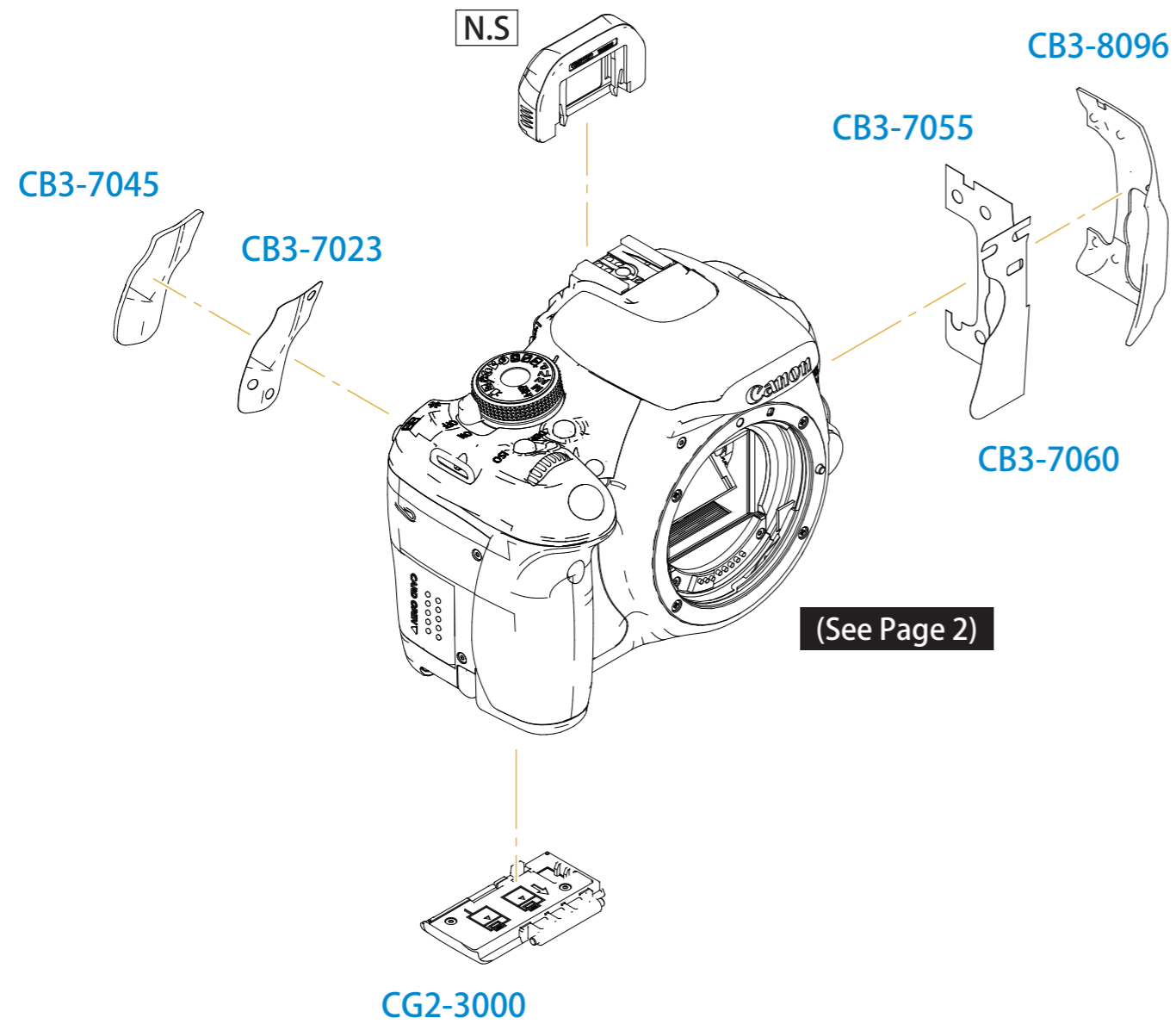

## PARTS LIST

REF. NO. C12-6311  
C12-6313  
C12-6315

| NEW | PARTS NO.    | CLASS | QTY | DESCRIPTION               |
|-----|--------------|-------|-----|---------------------------|
| *   | CB3-7023-000 | B     | 1   | TAPE, DOUBLE SIDE         |
| *   | CB3-7045-000 | C     | 1   | COVER, BACK (RUBBER)      |
| *   | CB3-7055-000 | C     | 1   | TAPE, DOUBLE SIDE         |
| *   | CB3-7060-000 | C     | 1   | TAPE, DOUBLE SIDE         |
| *   | CB3-8096-000 | C     | 1   | COVER ASS'Y, FRONT RUBBER |
| *   | CG2-3000-000 | C     | 1   | COVER ASS'Y, BATTERY      |

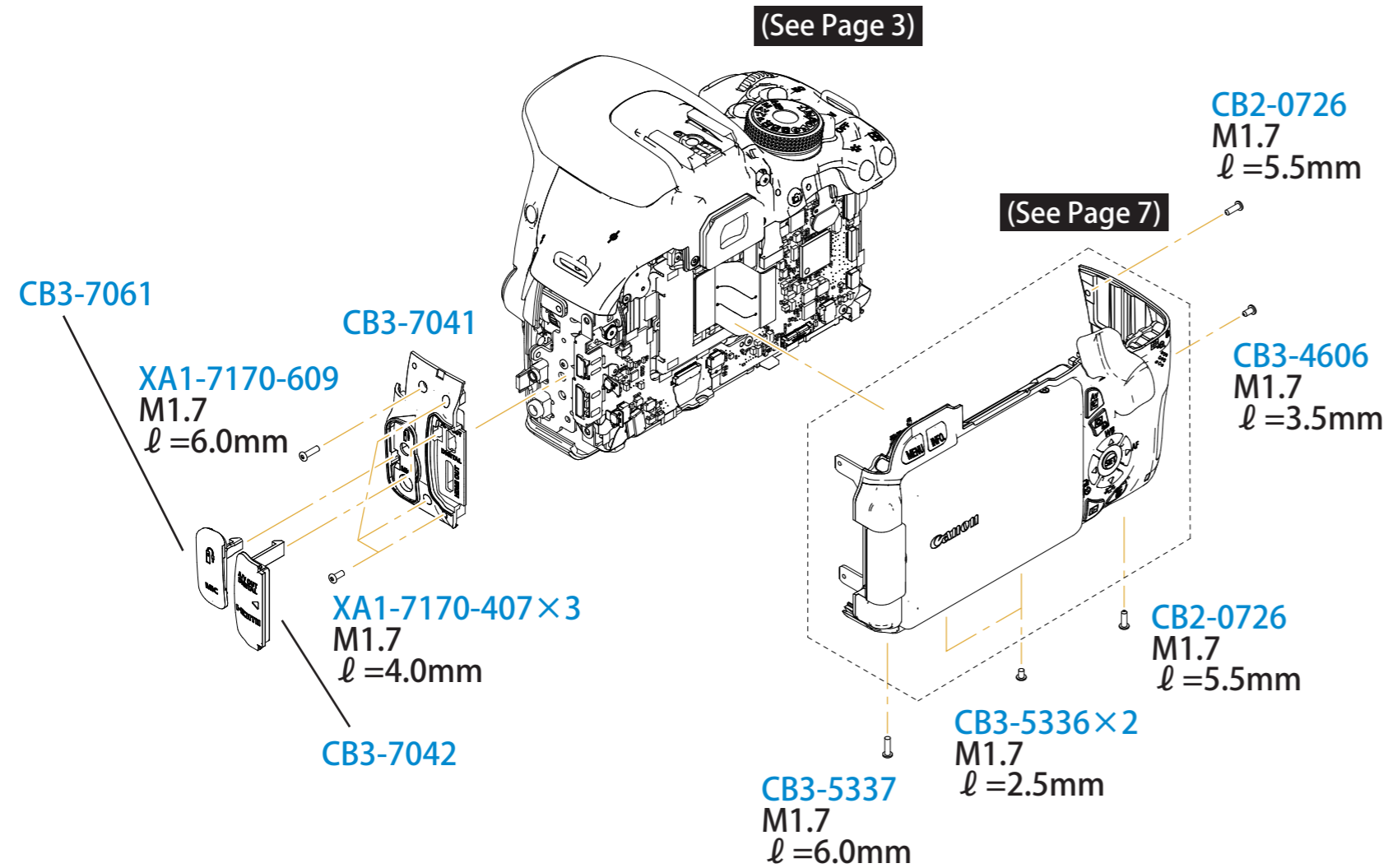

## PARTS LIST

REF. NO. C12-6311  
C12-6313  
C12-6315

| NEW | PARTS NO.    | CLASS | QTY | DESCRIPTION             |
|-----|--------------|-------|-----|-------------------------|
|     | CB2-0726-000 | C     | 2   | SCREW, M1.7X5.5         |
|     | CB3-4606-000 | C     | 1   | SCREW, M1.7X3.5 (BLACK) |
|     | CB3-5336-000 | C     | 2   | SCREW, M1.7X2.5         |
|     | CB3-5337-000 | C     | 1   | SCREW, M1.7X6.0         |
| *   | CB3-7041-000 | C     | 1   | COVER, I/F TERMINAL     |
| *   | CB3-7042-000 | C     | 1   | CAP, I/F TERMINAL R     |
| *   | CB3-7061-000 | C     | 1   | CAP, I/F TERMINAL L     |
|     | XA1-7170-407 | F     | 3   | SCREW, CROSS-RECESS, PH |
| *   | XA1-7170-609 | F     | 1   | SCREW, CROSS-RECESS, PH |

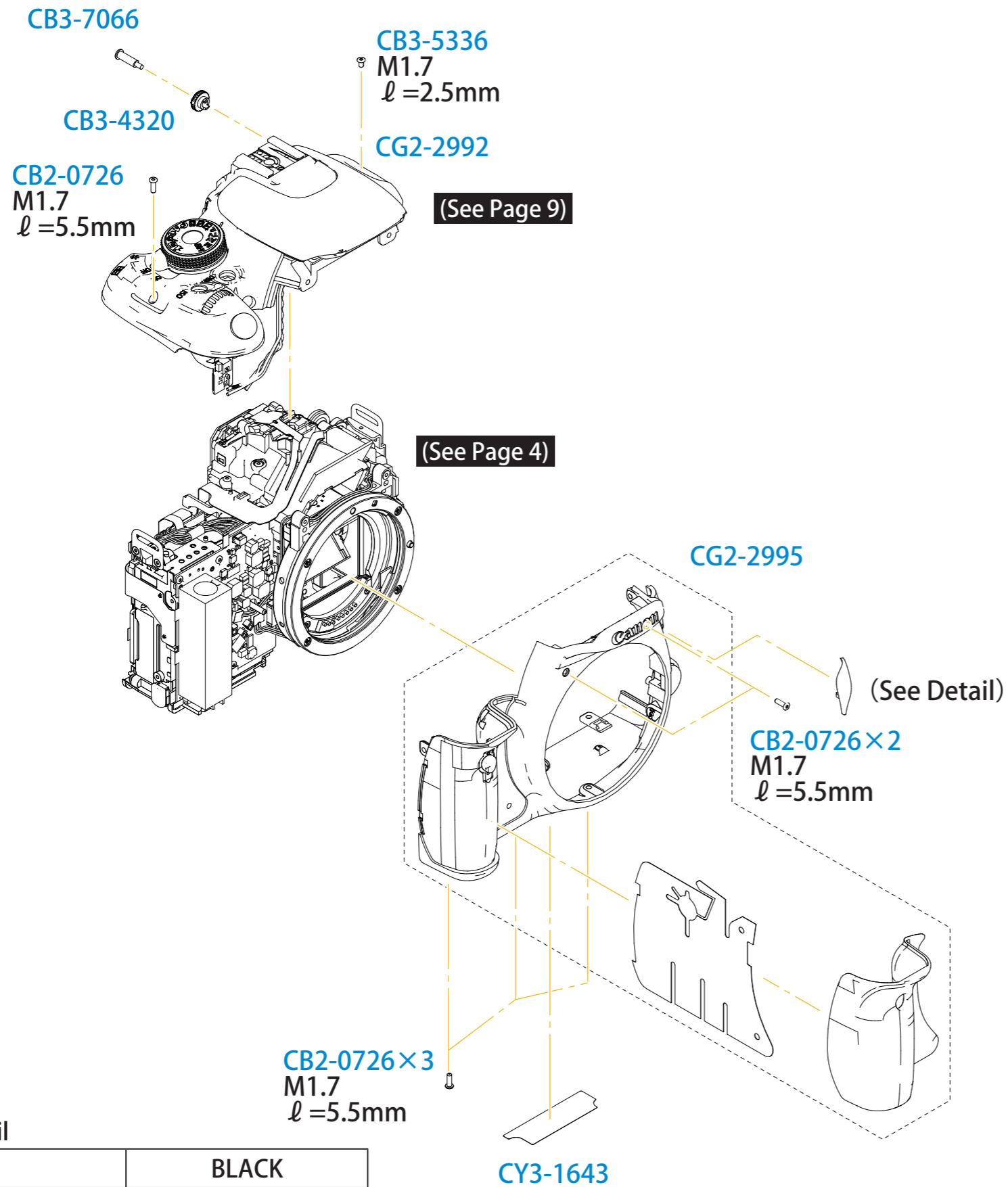

## Detail

|     | BLACK        |
|-----|--------------|
| JPN | CB3-7058-000 |
| USA | CB3-8115-000 |
| EUR | CB3-8116-000 |

| NEW | PARTS NO.    | CLASS | QTY | DESCRIPTION             |
|-----|--------------|-------|-----|-------------------------|
|     | CB2-0726-000 | C     | 6   | SCREW M17X5.5           |
|     | CB3-4320-000 | C     | 1   | DIAL, DIOPTER ADJUSTING |
|     | CB3-5336-000 | C     | 1   | SCREW, M1.7X2.5         |
| *   | CB3-7058-000 | C     | 1   | PLATE, NAME JAPAN       |
| *   | CB3-7066-000 | C     | 1   | SCREW                   |
| *   | CB3-8115-000 | C     | 1   | PLATE, NAME USA         |
| *   | CB3-8116-000 | C     | 1   | PLATE, NAME EURO        |
| *   | CG2-2992-000 | B     | 1   | COVER ASS'Y, TOP        |
| *   | CG2-2995-000 | C     | 1   | COVER ASS'Y, FRONT      |
| *   | CY3-1643-000 | C     | 1   | LABEL, BODY NUMBER      |

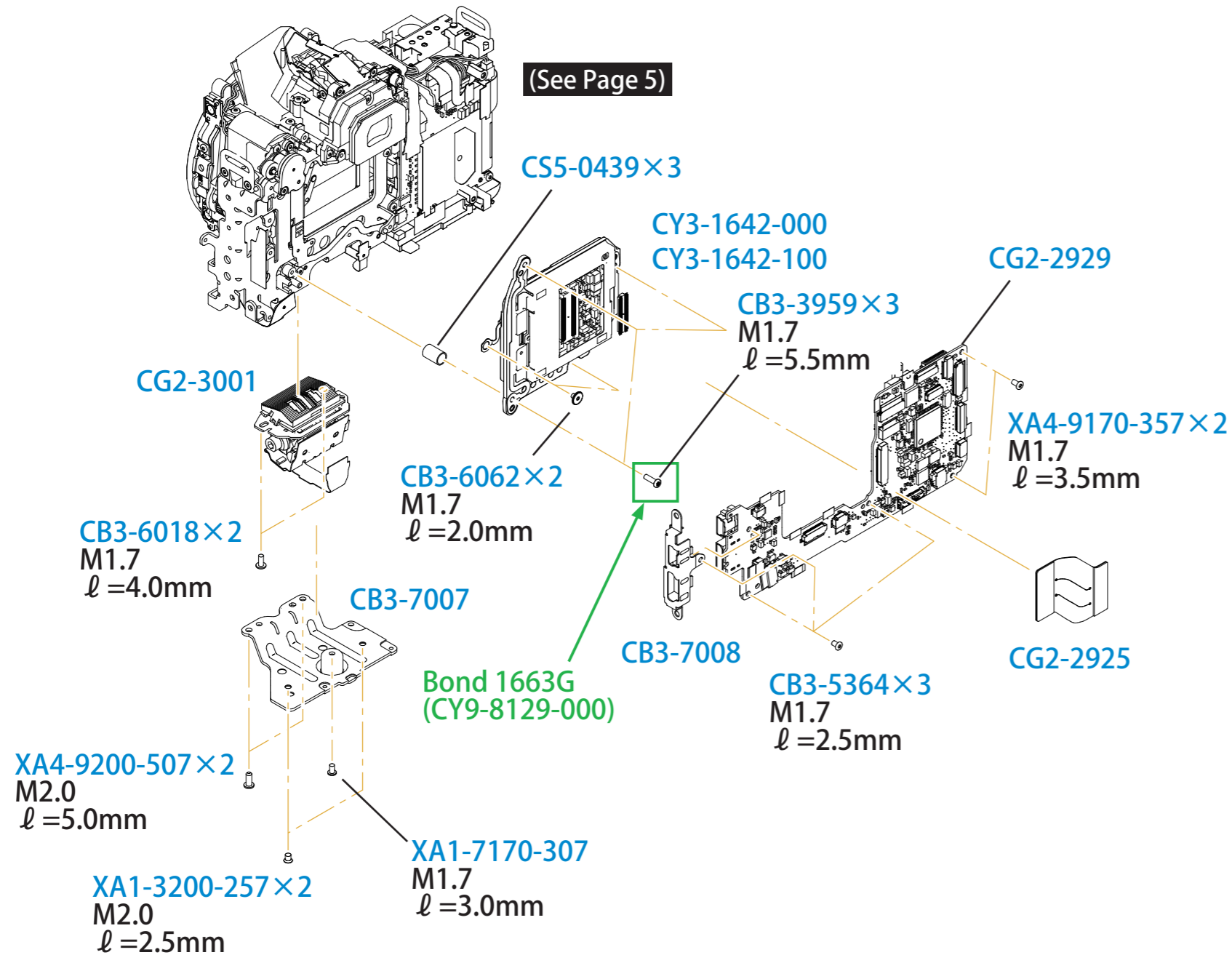

## PARTS LIST

REF. NO. C12-6311  
C12-6313  
C12-6315

| NEW | PARTS NO.    | CLASS | QTY | DESCRIPTION                  |
|-----|--------------|-------|-----|------------------------------|
|     | CB3-3959-000 | C     | 3   | SCREW, HEX M1.7X5.5          |
|     | CB3-5364-000 | C     | 3   | SCREW, M1.7X2.5              |
|     | CB3-6018-000 | C     | 2   | SCREW, M1.7X4.0              |
|     | CB3-6062-000 | C     | 2   | SCREW, M1.7X2.0              |
| *   | CB3-7007-000 | C     | 1   | PLATE, BOTTOM                |
| *   | CB3-7008-000 | C     | 1   | SHIELD, BACK TERMINAL        |
| *   | CG2-2925-000 | C     | 1   | FPC ASS'Y, IMAGE SENSOR      |
| *   | CG2-2929-000 | B     | 1   | PCB ASS'Y, MAIN              |
| *   | CG2-3001-000 | C     | 1   | FPC ASS'Y, AF                |
|     | CS5-0439-000 | C     | 3   | SPRING, IMAGE SENSOR         |
| *   | CY3-1642-000 | C     | 1   | CMOS SENSOR ASS'Y, W/O DATA  |
| *   | CY3-1642-100 | C     | 1   | CMOS SENSOR ASS'Y, WITH DATA |
|     | XA1-3200-257 | F     | 2   | SCREW                        |
|     | XA1-7170-307 | F     | 1   | SCREW                        |
|     | XA4-9170-357 | F     | 2   | SCREW, CROSS-RECESS, PH      |
|     | XA4-9200-507 | F     | 2   | SCREW, CROSS-RECESS, PH S    |

## NOTE

CY3-1642-000 : フランジバック補正值添付なし (\*1)

CY3-1642-100 : フランジバック補正值添付あり

\* 1 : CY3-1642-000 はフランジバックテスター (RSM-3200/4200) を所持している修理センター専用

## NOTE

CY3-1642-000: Without Flange Back Offset values attached (\*1)

CY3-1642-100: With Flange Back Offset values attached

\* 1: CY3-1642-000 is exclusively for repair facilities that own the Flange Back Tester (RSM-3200/4200).

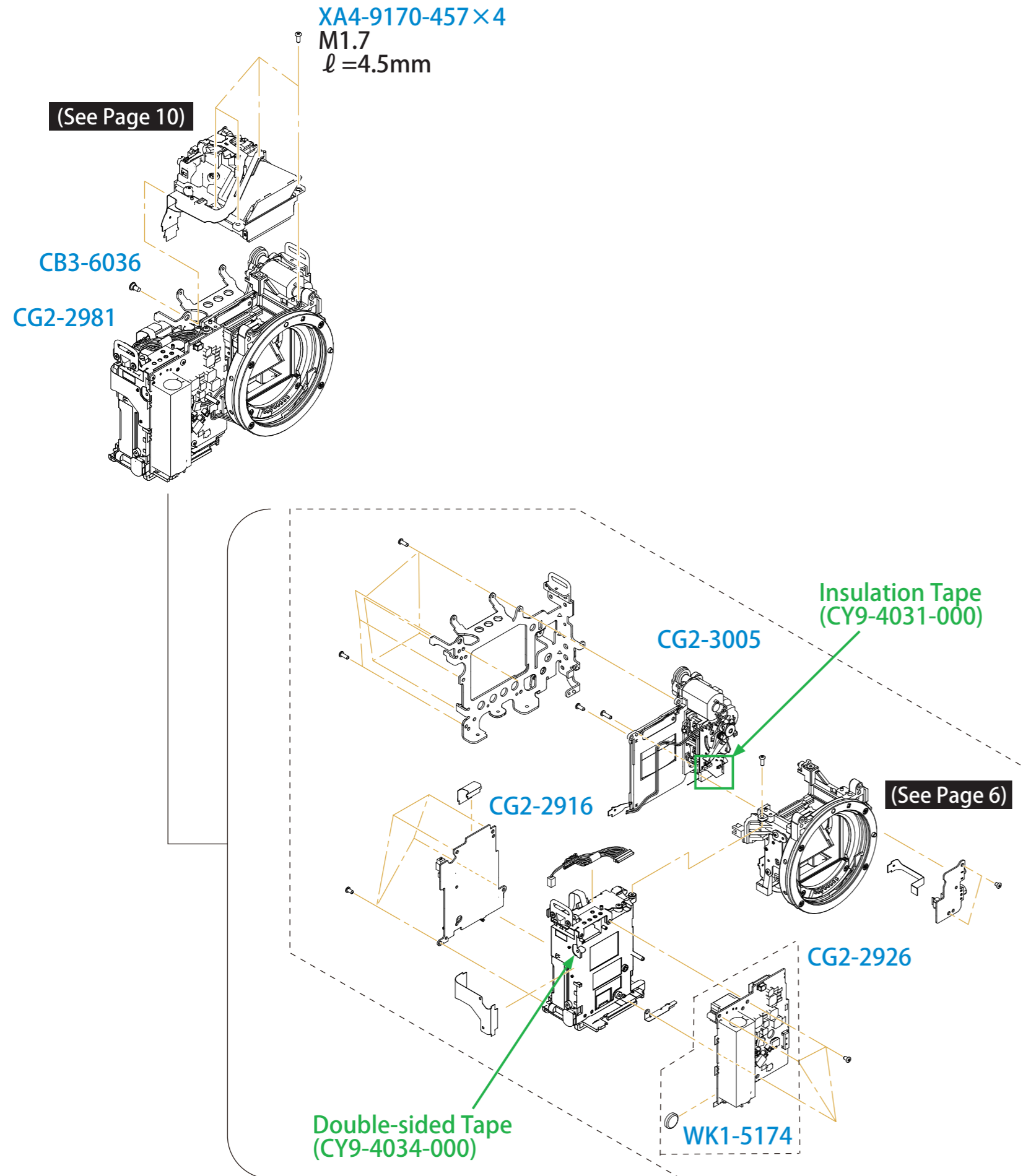

## PARTS LIST

REF. NO. C12-6311  
C12-6313  
C12-6315

| NEW | PARTS NO.    | CLASS | QTY | DESCRIPTION                   |
|-----|--------------|-------|-----|-------------------------------|
|     | CB3-6036-000 | C     | 1   | SCREW, PENTA HOLD             |
| *   | CG2-2916-000 | B     | 1   | PCB ASS'Y, SD                 |
| *   | CG2-2926-000 | B     | 1   | PCB ASS'Y, W/LI BATT,DC-DC    |
| *   | CG2-2981-000 | B     | 1   | MIRROR BOX ASS'Y, W/MAIN BASE |
| *   | CG2-3005-000 | B     | 1   | SHUTTER ASS'Y                 |
|     | WK1-5174-000 | N     | 1   | BATTERY, LITHIUM METAL <2ND>  |
|     | XA4-9170-457 | F     | 4   | SCREW, CROSS-RECESS, PH       |

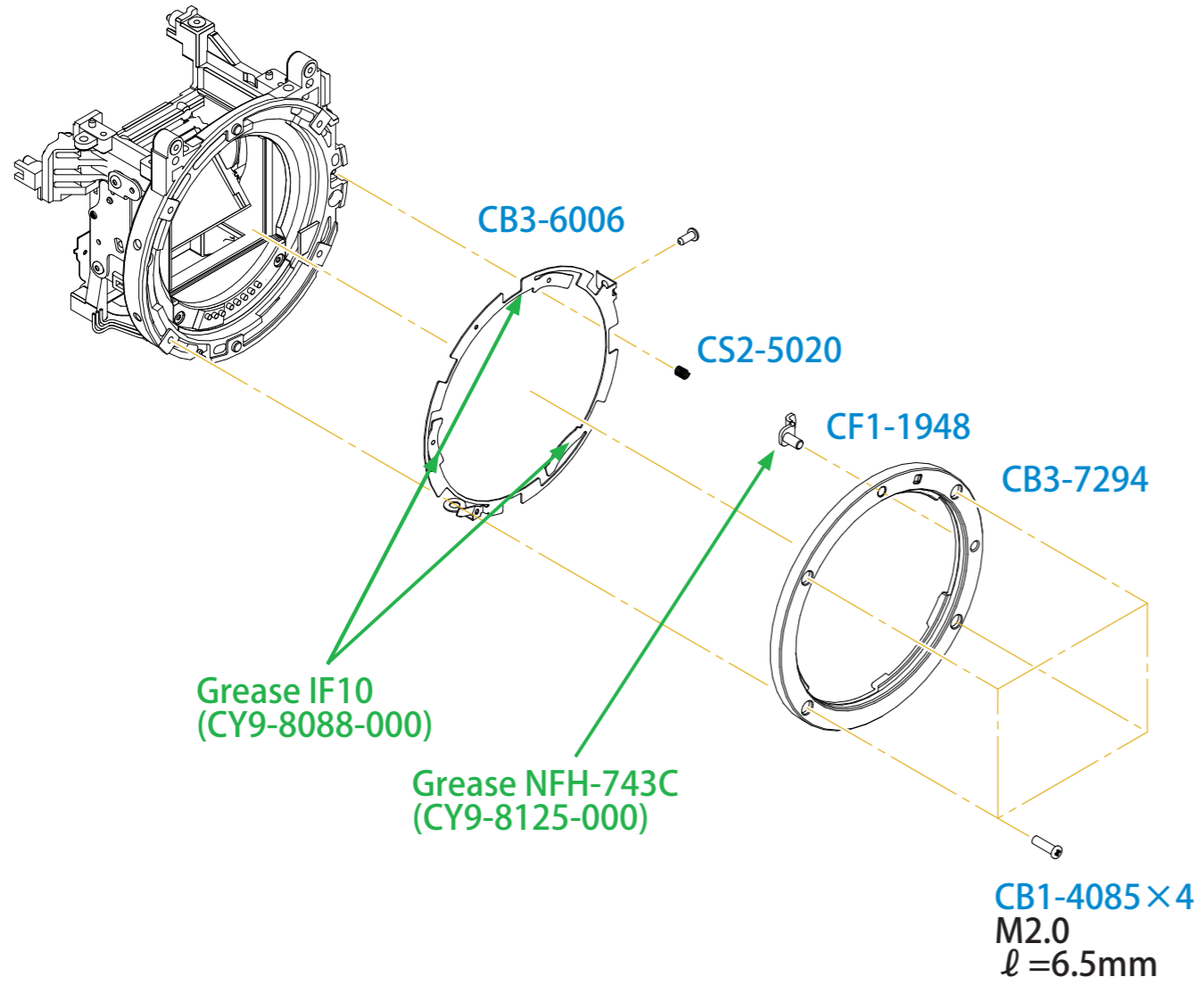

## PARTS LIST

REF. NO. C12-6311  
C12-6313  
C12-6315

| NEW | PARTS NO.    | CLASS | QTY | DESCRIPTION         |
|-----|--------------|-------|-----|---------------------|
|     | CB1-4085-000 | C     | 4   | SCREW, M2X6.5       |
|     | CB3-6006-000 | C     | 1   | SPRING, MOUNT       |
| *   | CB3-7294-000 | C     | 1   | MOUNT               |
|     | CF1-1948-000 | C     | 1   | LENS LOCK PIN ASS'Y |
|     | CS2-5020-000 | C     | 1   | SPRING, COIL        |

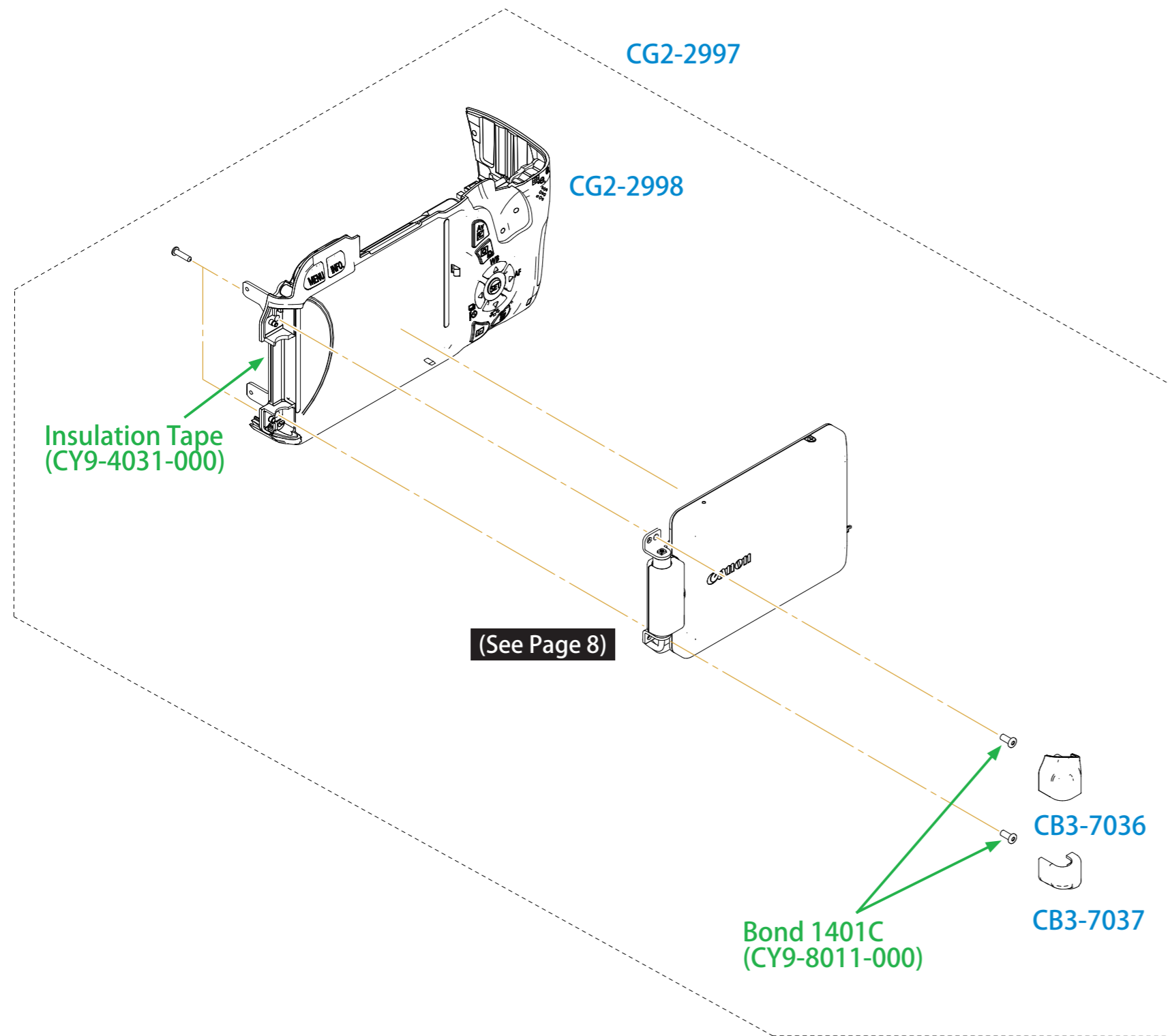

## PARTS LIST

REF. NO. C12-6311  
C12-6313  
C12-6315

| NEW | PARTS NO.    | CLASS | QTY | DESCRIPTION             |
|-----|--------------|-------|-----|-------------------------|
| *   | CB3-7036-000 | C     | 1   | COVER, HINGE TOP        |
| *   | CB3-7037-000 | C     | 1   | COVER, HINGE BOTTOM     |
| *   | CG2-2997-000 | C     | 1   | COVER ASS'Y, BACK W/TFT |
| *   | CG2-2998-000 | C     | 1   | COVER ASS'Y, BACK       |



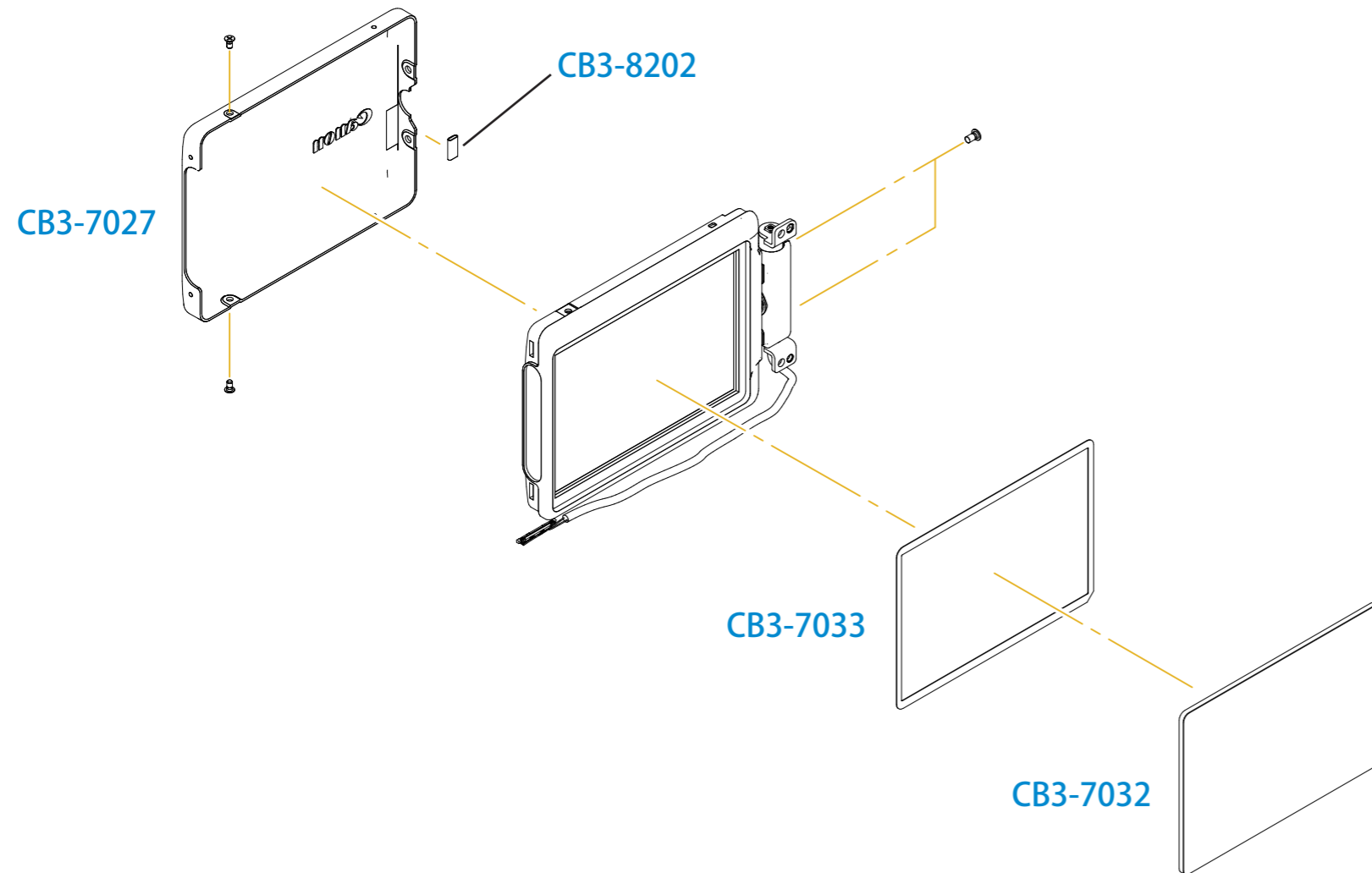

## PARTS LIST

REF. NO. C12-6311  
C12-6313  
C12-6315

| NEW | PARTS NO.    | CLASS | QTY | DESCRIPTION             |
|-----|--------------|-------|-----|-------------------------|
| *   | CB3-7027-000 | N     | 1   | COVER, TFT, REAR        |
| *   | CB3-7032-000 | C     | 1   | WINDOW, TFT DISPLAY     |
| *   | CB3-7033-000 | C     | 1   | TAPE, DOUBLE SIDE (TFT) |
| *   | CB3-8202-000 | N     | 1   | GASKET, EMI, TFT        |

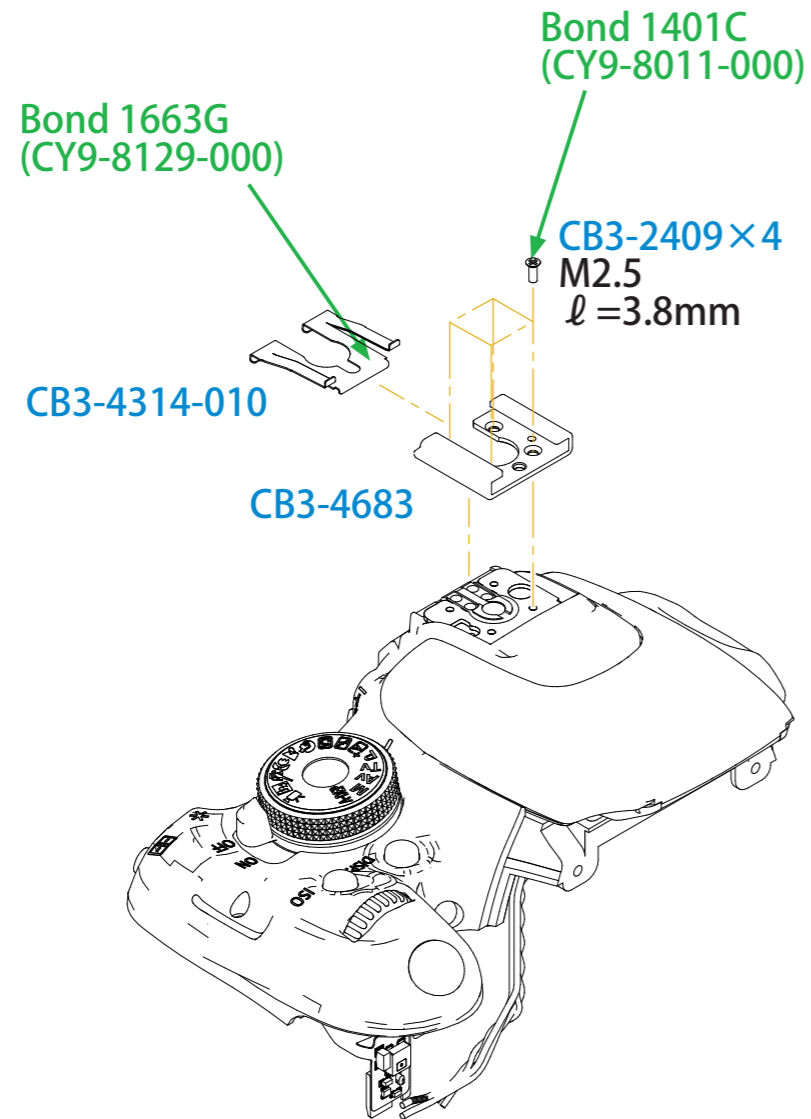

## PARTS LIST

REF. NO. C12-6311  
C12-6313  
C12-6315

| NEW | PARTS NO.    | CLASS | QTY | DESCRIPTION             |
|-----|--------------|-------|-----|-------------------------|
|     | CB3-2409-000 | C     | 4   | SCREW, M2.5X3.8         |
|     | CB3-4314-010 | B     | 1   | SPRING, ACC. SHOE PLATE |
|     | CB3-4683-000 | C     | 1   | SHOE, ACCESSORY         |

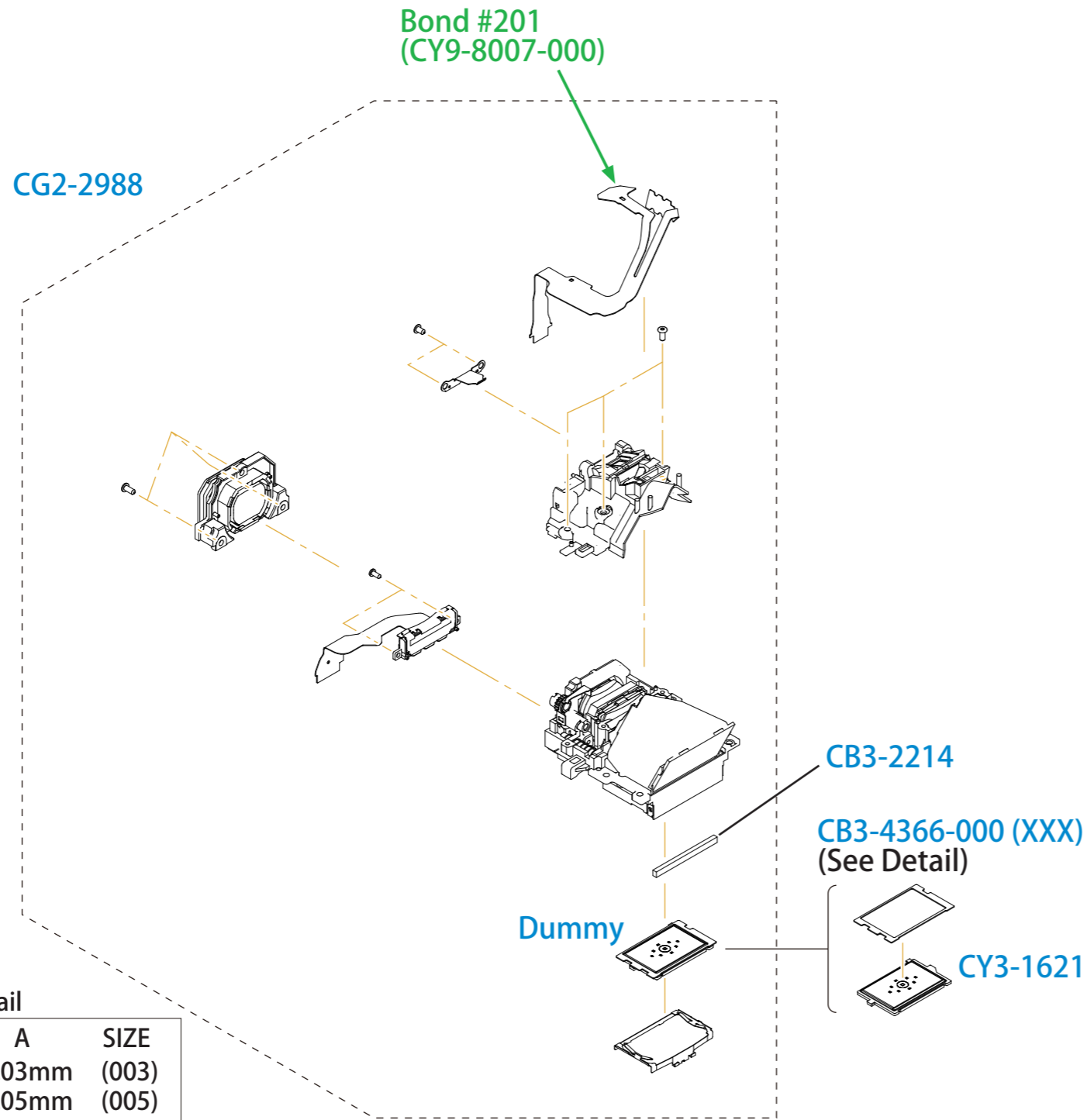

CB3-4366-000 (XXX) Detail

| A      | SIZE  |
|--------|-------|
| 0.03mm | (003) |
| 0.05mm | (005) |
| 0.08mm | (008) |
| 0.10mm | (010) |
| 0.12mm | (012) |
| 0.20mm | (020) |
| 0.33mm | (033) |

| NEW | PARTS NO.    | CLASS | QTY | DESCRIPTION              |
|-----|--------------|-------|-----|--------------------------|
|     | CB3-2214-000 | C     | 1   | CUSHION, MIRROR          |
|     | CB3-4366-000 | C     | 1   | WASHER, FINDER BACK ADJ. |
| *   | CG2-2988-000 | C     | 1   | FINDER ASS'Y             |
|     | CY3-1621-000 | C     | 1   | SCREEN, FOCUS 5PCS/BOX   |

## Accessories Section

BATTERY CHARGER LC-E8  
LC-E8E REF. NO. C51-0161(JPN)  
LC-E8C C51-0171(OTH)  
C51-0172(CHN)

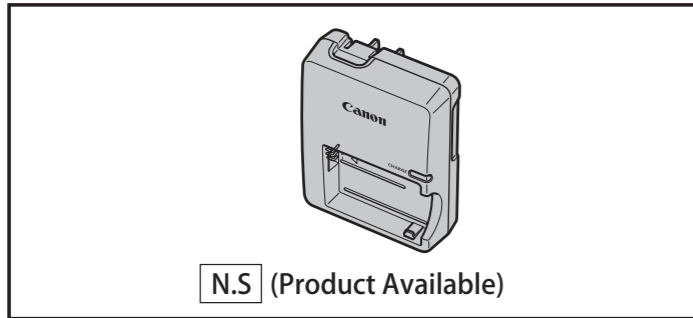

BATTERY PACK LP-E8 REF. NO. C51-0151(JPN)  
C51-0152(CHN)  
C51-0153(OTH)

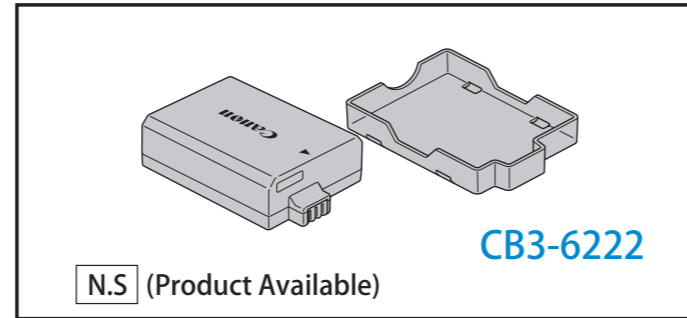

AC POWER CABLE REF. NO. C86-1092(EUR)  
C86-1093(AUS)  
C86-1095(CHN)  
D70-0028(USA)

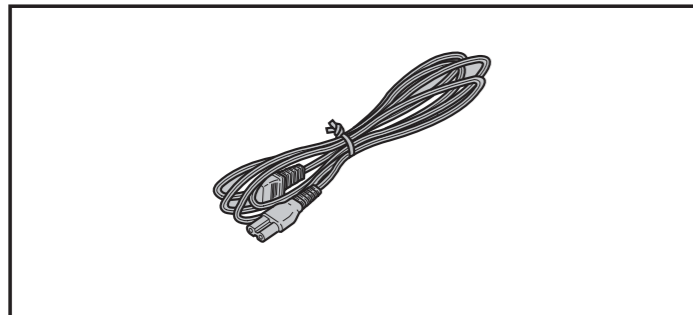

INTERFACE CABLE IFC-130U REF. NO. C58-5831

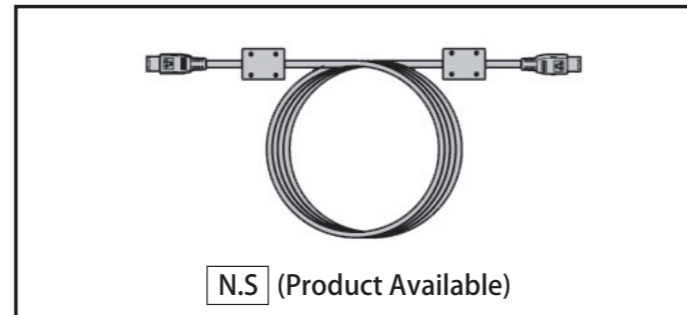

WIDE STRAP EW-100DB III REF. NO. C46-2251

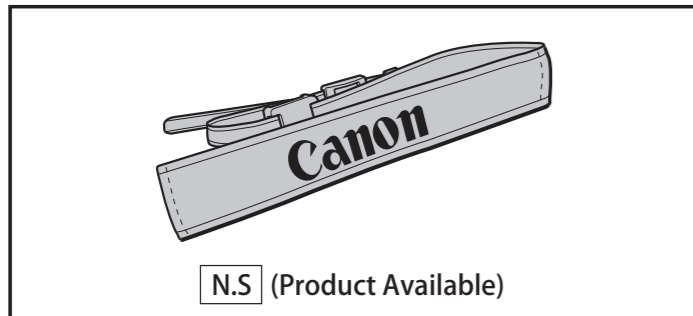

STEREO AV CABLE AVC-DC400ST REF. NO. C58-5851

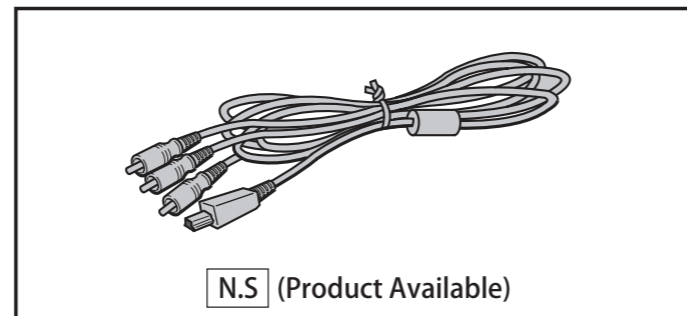

| NEW | PARTS NO.    | CLASS | QTY | DESCRIPTION               |
|-----|--------------|-------|-----|---------------------------|
|     | CB3-6222-000 | C     | 1   | COVER, BATTERY            |
|     | C86-1092-000 | C     | 1   | CABLE, AC, EUROPE (1M)    |
|     | C86-1093-000 | C     | 1   | CABLE, AC, AUSTRALIA (1M) |
|     | C86-1095-000 | C     | 1   | CABLE, AC, CHINA (1M)     |
| *   | D70-0028-000 | C     | 1   | CABLE, AC, USA (2M)       |