



LB 2300-2301-2302-2311-2312

**MAINTENANCE MANUAL FOR
TECHNICAL ASSISTANCE**



MANUAL CODE 10083445 / REL. 0.00 / APRIL 2010



LB 2300 Single cup 230 V

Machine code
10080606

**LB 2301 Single cup
230 V Steam**

Machine code
10080618

**LB 2302 Double cup
230 V Steam**

Machine code
10080712

**LB 2311 Single cup
120 V Steam**

Machine code
10080631

**LB 2312 Double cup
120 V Steam**

Machine code
10080632

Manual code
10083445

Rel. 0.00
Edition 04/2010
© Copyright LAVAZZA S.p.A.



Tel. 0039.011.2398429
Fax 0039.011.23980466
technicalservice@lavazza.it



Certificated n° IT09/0445

Index

1. GENERAL INFORMATION	1
1.1. Designated personnel	1
1.2. Structure of the manual	1
1.2.1. Scope and content	1
1.2.2. Users	1
1.2.3. Preservation	1
1.2.4. Messages used	1
1.2.5. Machine composition	2
1.2.6. Internal components	3
1.2.7. Range	4
1.2.8. Machine identification data	5
1.2.9. Technical specifications	5
1.2.10. Overall dimensions	5
1.2.11. List of the accessories supplied with the machine	5
2. GENERAL SAFETY RULES	6
2.1. Stop functions	6
2.2. Safety devices	6
2.3. Residual risks	6
3. INSTALLATION	7
3.1. Unpacking	7
3.2. Mounting-Positioning	7
3.3. Machine positioning	8
4. HANDLING AND STORAGE	8
4.1. Handling	8
4.2. Storage	8
5. DISMANTLING	8

6. USER MENU	9
6.1. Machine warnings	11
6.2. Machine programming (service provider)	14
6.3. Programming commands	15
6.4. Table of programming menu	16
6.5. Table of service menu	16
6.6. Parameter change	21
6.7. Exiting programming mode	21
7. DIAGRAMS	22
7.1. Wiring diagram	22
7.2. Hydraulic diagram	24
8. TROUBLESHOOTING	26
8.1. Test mode	26
8.2. Access to test mode	26
8.3. Troubleshooting	30
9. OPERATIONAL LOGIC	35
9.1. Reset of used capsule drawer	35
9.2. Reserve for product end	35
10. RECOMMENDED TOOLS	36
11. MOUNTING AND DISASSEMBLY OF THE MACHINE	
COMPONENTS	37
11.1. Upper body	37
11.2. GACO gasket replacement	41
11.3. Power cord replacement	42
11.4. Connector compartment	43
11.5. Steam pipe disassembly	44
11.6. Steam solenoid valve disassembly	44
11.7. Cup warmer plate disassembly	46
11.8. Capsule release coil disassembly	47

11.9.	Pump disassembly	47
11.10.	Turbine disassembly	48
11.11.	Capsule release unit disassembly	50
11.12.	Capacitive sensor disassembly	52
11.13.	Transformer disassembly	53
11.14.	Coffee thermostat disassembly	55
11.15.	Boiler disassembly	56
11.16.	Gear motor disassembly	57
11.17.	Perforator filter disassembly	58
11.18.	POWER board disassembly	63
11.19.	CPU board disassembly	63
11.20.	Keyboard board disassembly	64
11.21.	Display disassembly	65
11.22.	Assembly and removal of the OETIKER clamps	66

1. GENERAL INFORMATION

1.1. Designated personnel

The machine may be operated only by a qualified technician who has read this manual and, moreover who:

- is able to carry out repairs in case of serious malfunction and who has read this manual and all the information relative to safety;
- is able to understand the entire contents of the manual and to correctly interpret the drawings and diagrams;
- has knowledge of the appropriate hygiene, workplace safety, technology and security measures;
- has specific experience in the maintenance of vending machines;
- knows how to act in an emergency, where to find the personal protective equipment and knows how to use it.

Attention

The use of the machine by personnel without the prerequisites needed is prohibited.

1.2. Structure of the manual

The technician must carefully read the information in this manual.

1.2.1. Scope and content

This manual can provide the technician with all the information necessary for the maintenance of the machine.

Attention

Before any operation is carried out on the machine, the qualified technician must carefully read the instructions contained in this publication.

If there is any doubt about the correct interpretation of the instructions, contact the manufacturer to obtain the necessary clarification.

Attention

The undertaking of any operation on the machine, without having read and understood the contents of this manual is prohibited.

1.2.2. Users

This manual is designed for technicians qualified for the maintenance of the machine.

The manufacturer is not responsible for damage derived from the failure to follow this rule.

1.2.3. Preservation

In order to be able to guarantee the integrity and utility of this manual the following guidelines should be observed:

- employ this manual in such a way that it remains undamaged and whole;
- do not for any reason, remove, tear, or write over any part of the manual;
- keep the manual in an area protected from humidity and heat, in such a way that the quality and legibility of the publication are not compromised.

Warning

If this manual is damaged or lost, a new copy should be immediately requested from the manufacturer or authorised distributor of the country where the machine is used.

1.2.4. Messages used

Attention

The ATTENTION messages indicate a danger, possibly lethal, for the technician. The operations described after this message must be carried out carefully and safely using the personal protective equipment.

Warning

The WARNING messages are displayed before procedures that, if not observed, could cause damage to the machine..

Environment

The ENVIRONMENT messages are displayed before procedures that, if not observed, could cause damage to the environment..



Note

The NOTE messages show further information useful for the maintenance technician.

1.2.5. Machine composition

Note: if not expressly indicated in the text, the position numbers of the machine parts are referred to this figure.

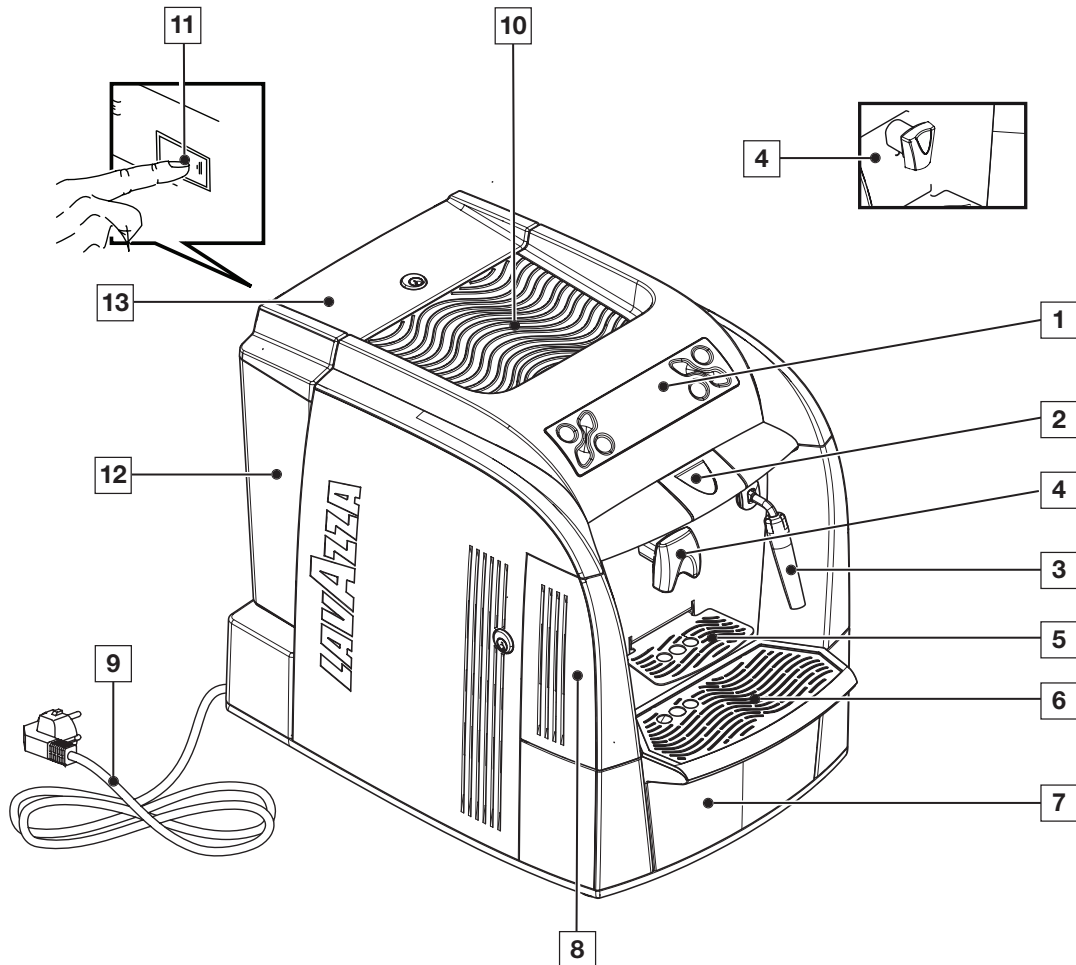

- 1 Control panel
- 2 Capsule loading tray
- 3 Steam/hot water pipe (according to the model)
- 4 Coffee dispensing spout (the dispensing spout allows brewing 1 or 2 coffees according to the model)
- 5 Cup support (small cups)
- 6 Cup support (mugs)
- 7 Used capsule drawer and drip tray
- 8 Service area access door
- 9 Power cord
- 10 Cup warmer plate (according to the model)
- 11 On/off switch
- 12 Water tank
- 13 Water tank lid

1.2.6. Internal components

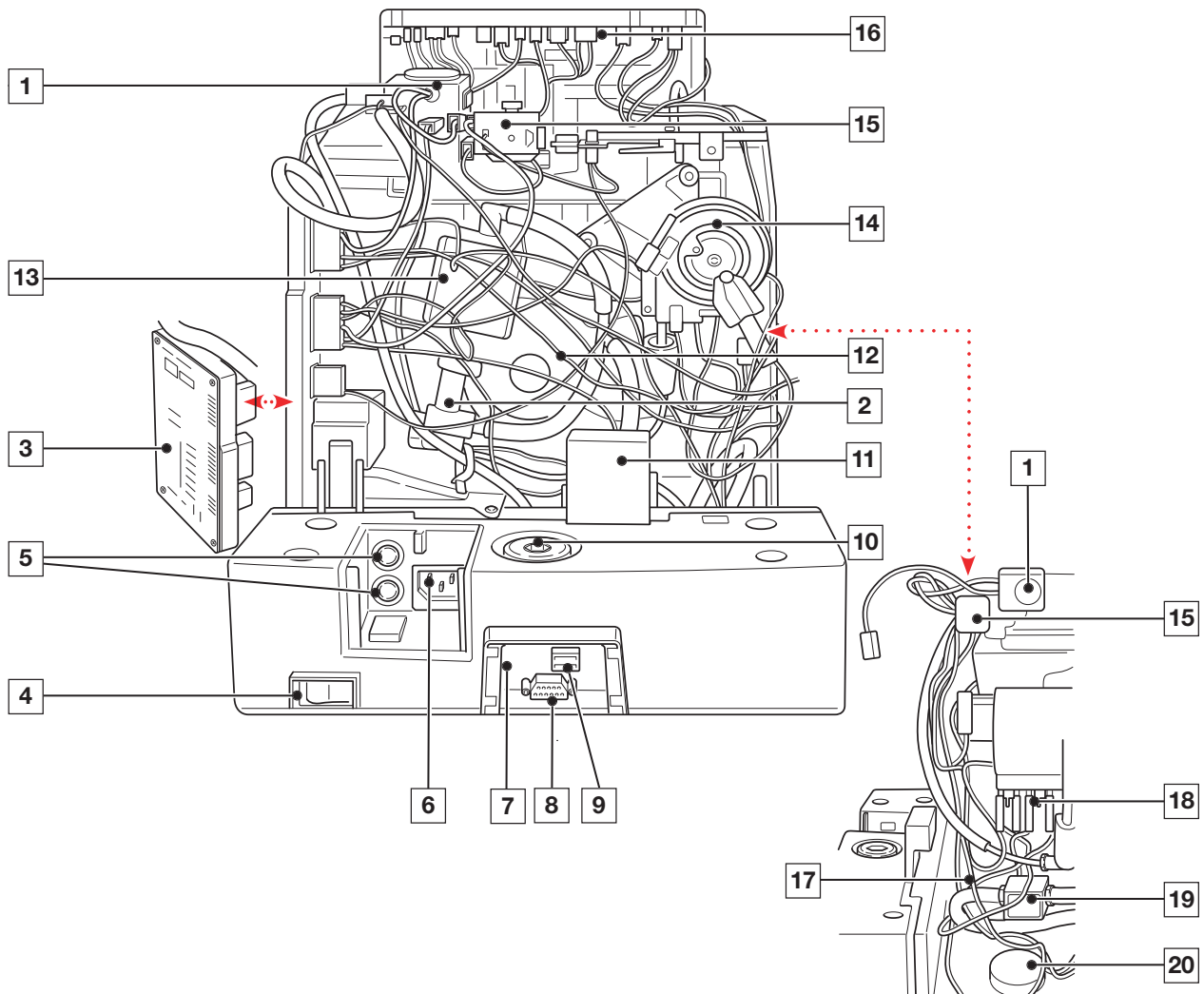

- | | | | |
|----|---------------------------------|----|----------------------|
| 1 | Steam solenoid valve | 12 | Gear motor |
| 2 | Pressure relief valve | 13 | Pump |
| 3 | Power board | 14 | Boiler |
| 4 | On/off switch | 15 | Capsule release coil |
| 5 | Safety fuses | 16 | CPU board |
| 6 | Connection for power cord | 17 | Noise filter |
| 7 | IRDA for programming | 18 | Safety thermostats |
| 8 | RS232 connector for programming | 19 | Water solenoid valve |
| 9 | Connector for payment systems | 20 | Flowmeter |
| 10 | Coupling for water tank | | |
| 11 | Capacitive sensor | | |

1.2.7. Range

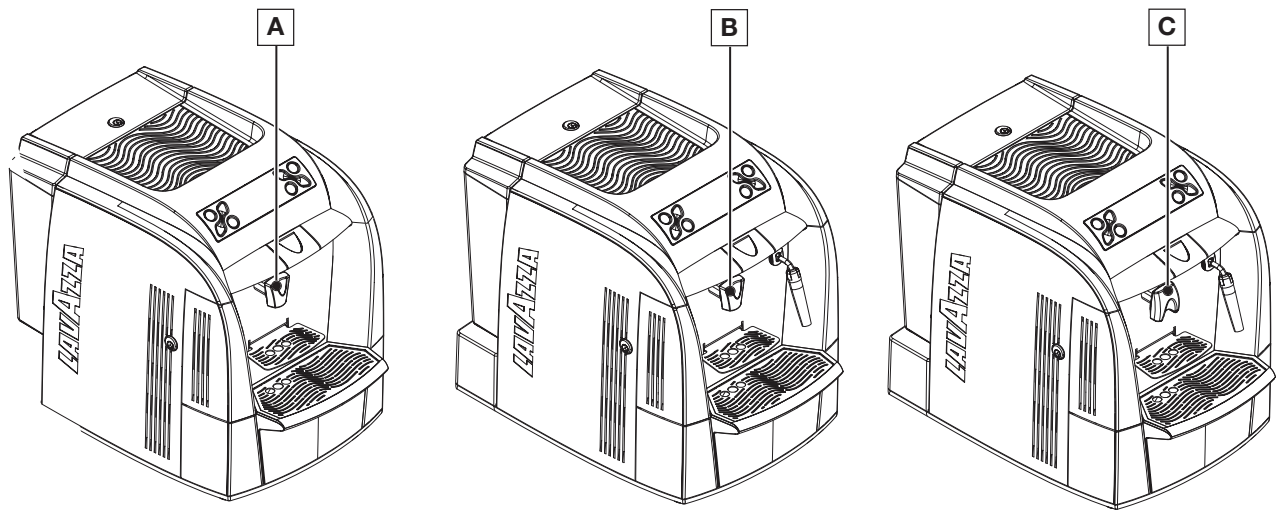

Dispensing spout for 1 product (A)



Dispensing spout for 1 product (B)
Steam/hot water pipe

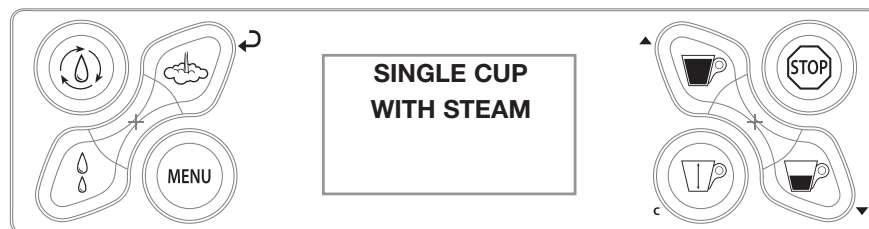

Dispensing spout for 2 products (C)
Steam/hot water pipe

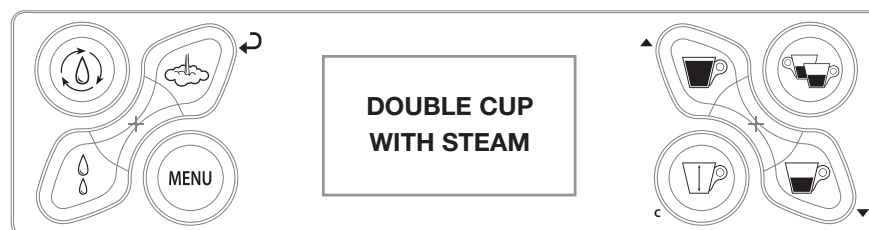

1.2.8. Machine identification data

In the plate the following identification data of the machine are indicated:

- Manufacturer;
- Machine name;
- Serial number;
- Power supply voltage (V) and frequency (Hz);
- Power consumption (W);
- Water mains pressure (MPa).



Note

In case of contact with authorized service centres, please indicate the model and serial number.

1.2.9. Technical specifications

Power supply voltage:

230 V~, 50 Hz

120 V~, 60 Hz

Power

Total: 1570 W

1100 W Coffee/hot water dispensing

470 W Additional for steam dispensing

Safety system:

Thermostat

Water level sensor:

Capacitive sensor

Pump:

Ulka brand with alternate piston and thermal protector 100°C

48 W, 230V, 50 Hz, Type EP5 ca. 13-15 bar

Pressure relief valve:

Opens at 13-14 bar about

Water filter:

In the tank

Consumption:

During heating phase- about 6,8 A

Weight:

10,5 kg

Water tank capacity:

4 litres

Capsule container capacity:

Max. 20

Operating conditions:

Minimum temperature: 10°C

Maximum temperature: below 40°

Maximum humidity: below 95%

Brewing temperature:

about 73°C - 83°C

1.2.10. Overall dimensions

Deep: 473 mm

Width: 327 mm

Height: 391 mm

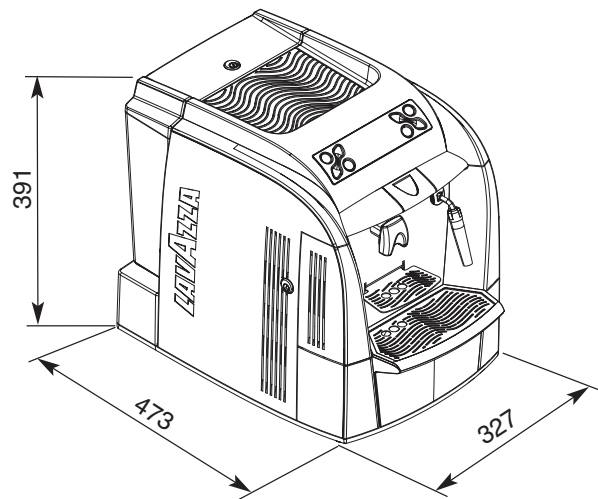

1.2.11. List of the accessories supplied with the machine

Booklet: Instructions for using the machine.



Water hardness test: Quick test to determine the hardness of the water used to prepare beverages; this is a very important test to set the hardness of the water used by the machine.

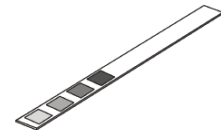

Key for water tank access: prevents access to water tank by unauthorised personnel.

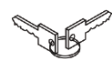

BRITA INTENZA filter

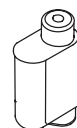

2. GENERAL SAFETY RULES

Attention

Read the entire manual carefully and the following general safety rules..

- Power connection should be made in compliance with local standards in force.
- The electric socket connecting the machine should:
 - conform to the type of plug installed on the machine;
 - comply with the data provided on the plate placed on the bottom of the apparatus;
 - be connected to ground.
- The electric parts of the machine must not:
 - enter into contact with any type of liquid: danger of electric shock and/or fire;
 - be manipulated by humid or wet hands;
 - be tampered with.
- It is forbidden:
 - To use the machine near flammable substances and/or explosives and/or in an atmosphere with any risk of fire;
 - To use spare parts not advised by the manufacturer;
 - Carry out any type of technical modification not covered in the normal procedures of diagnosis and repair.
- Before carrying out any operation on the machine ensure that the plug is disconnected from the current and that the machine has cooled.
- Maintenance operations on the machine should be carried out by a single person; if a second person must intervene, this person should be advised of the potential hazards relevant to the operation underway.
- In case of fire use carbon dioxide (CO₂) extinguishers. Do not use water or powder extinguishers.

Attention

During the repair of the machine all the normal safety protections, designed to avoid accidents are disabled. Adopt all the measures necessary to avoid accidents.

2.1. Stop functions

To stop the machine turn the main switch to "0" (OFF).

2.2. Safety devices



Note

The machines described in this publication, are designed in compliance with the specific European standards in force and therefore have measures of protection in all the potentially hazardous parts.

Two Klixon thermostats with manual reset avoid any overheating of the boiler.

2.3. Residual risks

In this chapter are illustrated the risks that the user may incur in if he doesn't comply with the specific safety rules (as described in this booklet).

The appliance must be connected to ground

If it is not done, the appliance can become a source of dangerous electrical discharges as it is no longer able to discharge electricity to earth.

Do not use running water for washing

The use of pressurised water directly on the machine can seriously damage electrical appliances. Never use water jets to wash any part of the appliance.

Be careful with the hot water pipe

During use the hot water pipe may overheat, thus becoming a source of danger. Handle this part carefully. Never direct steam or hot water jets directly on parts of the body.

Do not work on the machine when it is powered

Before carry out any maintenance or repair on the machine you must turn it off by means of the main network switch, or better yet, disconnecting the connection terminals in the network. Never remove any body panels when the machine is supplied with electrical power.

Use of the appliance

This espresso coffee machine is an appliance for professional use only. Any other type of use is considered incorrect and therefore dangerous. Never allow children or incapacitated persons to use the machine..

Attention

Non-observance of the above rules can cause serious harm to people, property or animals.

Never operate the electronic components when the machine is still supplied with electrical power.

Shut off the machine completely by unplugging it from the mains before carrying out any operation.

Attention

Any operation taken by the technician on the electronics of the machine when the machine is powered, automatically invalidates any guarantee.

The technician should know that the machine is electrically connected and act accordingly.

Attention

Burn danger – During hot water and steam dispensing, do not direct the jets toward others or yourself. Grasp the pipe, exclusively on the relevant protectors (12 and 17).

Warning

Do not use any containers that are not suitable for foodstuffs.

3. INSTALLATION

3.1. Unpacking

Open the packaging, taking care not to damage it. Remove the machine protections and the equipment contained in the package. Take the machine out.

3.2. Mounting-Positioning

Warning

It is prohibited to install the machine outside or in places where water or steam jets are used.

Warning

The presence of magnetic fields or proximity with electric machines which generate disturbances, may cause malfunctions in the electronic control of the machine.

Warning

With temperatures approaching 0°C there is the risk of freezing internal parts of the machine which contain water. Do not use the machine under these conditions.

For the correct operation of the machine, the following advice is given:

- environmental temperature: 10°C ÷ 40°C;
- maximum humidity: 90%;
- the area must be ready for the installation of the machine;
- the place where the machine is installed should be flat, solid and still; the surface must not have an inclination of more than 2°;
- the area should be sufficiently illuminated, ventilated, hygienic and equipped with a readily available power outlet.

Attention

Sufficient space must be allowed to access the machine and the plug, to allow the user to move freely and to be able to immediately leave the area in an emergency.

3.3. Machine positioning



Note

For a correct ergonomic use of the machine, place it on a working surface not lower than one meter from the floor.

Warning

Check that the surface prepared for the machine installation, has dimensions and sturdiness suitable to safely support the machine.

4. HANDLING AND STORAGE

4.1. Handling

During handling and transport, the machine must remain in a vertical position according to the directions on the packaging. Carry out lifting and positioning with care. Do not shake the machine.

4.2. Storage

The machine should be stored according to the following conditions:

- minimum temperature: above 4°C;
- maximum temperature: below 40°C;
- maximum humidity: below 95%.

The machine is packaged in cardboard and polystyrene.

5. DISMANTLING

Environment

Disposal of machine components after dismantling, should be carried out with respect for the environment, avoiding pollution of the soil, water and air. Any operation should comply with local legislation in force.

6. USER MENU

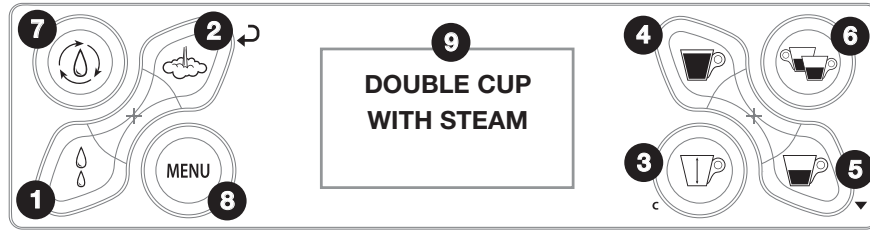





BUTTON	DESCRIPTION
1) Hot water dispensing	Press this button for 1 second and the machine immediately dispenses hot water.
2) Steam dispensing	Press this button for 1 second and the machine immediately dispenses steam.
3) Manual dispensing button	Press this button to dispense a quantity of product that the user can manually control (the user must stop the dispensing by pressing again the button).
4) Long coffee button	Press this button and the machine dispenses a long coffee (dose programmed by the service provider).
5) Espresso button	Press this button and the machine dispenses an espresso coffee (dose programmed by the service provider).
6) Double espresso	Press this button and the machine dispenses a double espresso.
7) Rinse	Press this button for 1 second to carry out a rinse cycle of the internal circuits.
8) MENU	Press this button for 1 second to display the user menu.
9) LCD display	Displays the machine status and alarm signals, and guides the user to operate the machine.
10) Stop	Press this button to stop coffee or steam/hot water dispensing.
11) Language	Press this button for 1 second to display messages in the desired language.

Press the MENU button (8) to access the QUICK MENU that allows the following operations:

- Change the language
- Activate/deactivate the cup warmer (according to the model)
- Wash the brew unit
- Set the rinse cycles
- Descale the machine
- Activate/deactivate the stand-by mode (to activate the energy saving mode)

BUTTON	DESCRIPTION
2) Enter/Confirm	Press the button to select the function or confirm the command.
6) Page UP	Press the button to change function or parameter.
8) ESC	Press the button to exit the function.
9) Page DOWN	Press the button to change function or parameter.

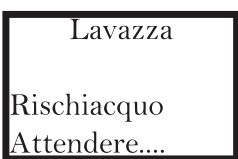
6.1. Machine warnings

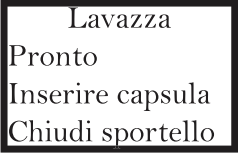
DISPLAY	MEANING	ACTIONS
	The machine is checking the components.	Wait for the check to conclude automatically.
	The machine is warming up	Wait for this step to conclude automatically.
	The machine is performing the circuit rinse cycle with fresh water.	Wait for the rinse cycle to end automatically.
	The machine is ready to brew coffee.	It is possible to dispense the coffee/product.
	The capsule loading tray has been opened.	Place a capsule in the tray and close it. Close the tray without the capsule.

DISPLAY	MEANING	ACTIONS
Lavazza Pronto Scegli prodotto	The tray has been closed with a capsule inside.	Dispense the product.
Lavazza Acqua calda Premere un tasto per finire	The machine is dispensing hot water.	Stop the dispensing by pressing the hot water button.
Lavazza Vapore Premere un tasto per finire	The machine is dispensing steam.	Stop the dispensing by pressing the steam button.
Lavazza Pronto Decalcificare	The machine signals that a descaling cycle has to be carried out.	Start the descaling cycle.
Lavazza Pronto Crediti Scarsi	The machine is alerting the user that credits for product brewing have almost run out.	Request assistance from the service provider to acquire new credits.
Lavazza Pronto Vuotare fondi	Indicates that the used capsule drawer should be emptied, though further products can still be dispensed.	With the machine stopped and switched on, remove the used capsule drawer and empty it.
Lavazza Vuotare cassetto fondi	Indicates that the used capsule drawer must be emptied because further products may not be dispensed.	With the machine stopped and switched on, remove the used capsule drawer and empty it.
Lavazza Attendere...	The used capsule drawer has been removed following a machine warning.	Empty the used capsule drawer and wait for the following message "insert drawer" to appear.
Lavazza Erogazione interrotta Attendere	The machine has interrupted the brewing cycle.	An alarm signal has been triggered, stopping the brewing cycle. Contact the service provider, if necessary.

DISPLAY	MEANING	ACTIONS
<div style="border: 1px solid black; padding: 5px;"> Lavazza Preinfusione Attendere... </div>	The machine is performing the pre-infusion cycle and stops brewing the product.	Wait for the product brewing to restart automatically.
<div style="border: 1px solid black; padding: 5px; text-align: center;">  </div>	The machine has started the product brewing cycle.	Wait for the brewing automatically or manually to end.
<div style="border: 1px solid black; padding: 5px;"> Lavazza Fine erogazione Attendere... </div>	End brewing, the machine is being returned to the ideal conditions for the next brewing cycle.	
<div style="border: 1px solid black; padding: 5px;"> Lavazza Inserire cassetto fondi </div>	The used capsule drawer has been removed from its seat.	Insert the used capsule drawer.
<div style="border: 1px solid black; padding: 5px;"> Decalcificazione Pronto Riempire acqua </div>	The machine alerts that the water tank should be filled though further product can still be dispensed.	Fill the water tank.
<div style="border: 1px solid black; padding: 5px;"> Lavazza Riempire serbatoio acqua </div>	The water tank is empty.	Fill the water tank.
<div style="border: 1px solid black; padding: 5px;"> Lavazza Chiudere la porta </div>	The front service door is open.	Close the door. If the door is closed and the warning persists, request assistance.
<div style="border: 1px solid black; padding: 5px;"> Lavazza Fuori Servizio XX Chiamare assist. </div>	There is a machine malfunction.	Refer to the notes on chap. 8.3.
<div style="border: 1px solid black; padding: 5px;"> Lavazza Stand-By Premere un tasto per iniziare </div>	The machine is in energy saving mode.	Press any button or open the capsule loading tray to activate the machine.

DISPLAY	MEANING	ACTIONS
<div style="border: 1px solid black; padding: 5px;"> Lavazza Caricamento Acqua Attendere... </div>	The machine is filling the hydraulic circuit.	Wait for this operation to be successfully completed.
<div style="border: 1px solid black; padding: 5px;"> Lavazza Pronto Cambiare filtro </div>	The descaling filter must be replaced.	Request assistance from the service provider.

6.2. Machine programming (service provider)

To access the **programming menu** carry out the following:

Turn the machine off using the on/off switch.

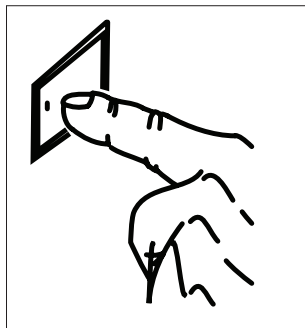

Turn the machine on using the on/off switch and while the hourglass shows up, keep pressed the steam button until the menu appears.

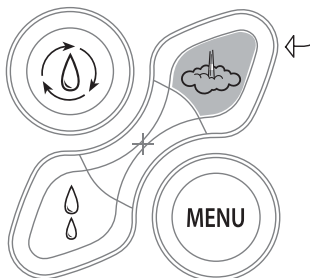

Attention

These menus are **PASSWORD** protected.

Attention

The chosen **PASSWORD** (default 0000), should be changed during the first machine start up in such away to prevent unauthorised access.

It is possible to change the password using either the service or the programming menu.

Programming menu	Access to the programming menu (the password is requested)
Service menu	Access to the service menu (the password is requested)
Exit	Exits the programming menu

6.3. Programming commands

The buttons of the control panel have different functions when the programming or service menu are entered.

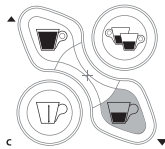
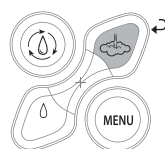
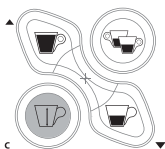
	"Page up/change" button	This button allows :	<ul style="list-style-type: none"> - Scrolling the pages within a menu - Changing the parameters when they are made editable using the "OK" button
	"Page down/change" button	This button allows :	<ul style="list-style-type: none"> - Scrolling the pages within a menu - Changing the parameters when they are made editable using the "OK" button
	"OK" (ENTER) button	This button allows :	<ul style="list-style-type: none"> - Selecting the displayed function - Making changeable a parameter/value - Confirm the parameter/value when it is made editable
	"ESC" button	This button allows :	Exiting without changing the edited or selected parameter.

6.4. Table of programming menu

1. Programming menu		Press ENTER to access the programming menu		
Password	Enter password	Set value Default: 0000	Enter the previously stored password (4 digits) for accessing the password function	
1.1. Identification	1.1.1. Admin/affiliate PIN Default 00000		Identifies the Service Provider or Administrator's code: Numerical value between 0 and 65535	
	1.1.2. Model		(Read only) Identifies the machine model.	
	1.1.3. Version		(Read only) Identifies the version of the machine's software.	
	1.1.4. Point of sale Default 00000		Identifies the point of sale: Numerical value between 0 and 65535. Enter the selected number. This number will then be displayed.	
1.2. Setup	1.2.1. Standard temperature Default: 100°C		Boiler operating temperature (in degrees centigrade) when the machine is ready to be used. Range: 90° - 105°.	
	1.2.2.Progr.dose	1.2.2.1.Short prod.dose Default: 140	Quantity for espresso coffee (this is a numerical parameter with no physical correspondent, e.g. cc).	
		1.2.2.2.Long prod. Dose Default 173	Quantity for long coffee (this is a numerical parameter with no physical correspondent, e.g. cc).	
		1.2.2.3.Free prod.dose Default 615	Maximum amount of manually dispensed product (this is a numerical parameter with no physical correspondent, e.g. cc).	
		1.2.2.2.Double dose prod.dose Default 210	Quantity for double espresso coffee (this is a numerical parameter with no physical correspondent, e.g. cc).	
	1.2.3.Pre-infusion Default: Media		Pre-infusion time No, Short, Medium, Long	
	1.2.4.Filter coffee Default: No		"Yes" enables the filter coffee function. Filter coffee can only be brewed by pressing "ESC". The filter operation is not available.	
	1.2.5. Descaling	1.2.5.1. Water hardness Default: 3		Values 0-4. "0" disables descaling checks. With hardness 1, 2, 3 and 4, descaling checks are activated and an alarm signal will appear after 240, 180, 120 or 60 litres of water that have been treated. (Values from 5 to 9 will not be accepted)
			1.2.5.2. Descal.warning Default: Yes	"Yes" enables display of the descaling alarm signal.
	1.2.6. Filter warning Default: No		"Yes" enables display of the filter replacement alarm signal. When enabled, the alarm signal appears after approximately 60 litres of water have been treated, or in any event after 60 days.	

1.2. Setup	1.2.7.Credits	1.2.7.1.Credit check	(Read only) Yes: the machine checks the remaining credits. No: The machine does not check remaining credit.
		1.2.7.2.Credit warning Default: Yes	“Yes” enables - display of the credit alarm signal when the preset minimum number of credits is reached; - display of the "no credit" alarm signal when the credits have been run out
		1.2.7.3.Load credits Default: 000	Number of credits added. Value: 0-255
	1.2.8.Language Default: Italian		Select language
	1.2.9.Grounds delay Default: 5		Time, in seconds, after which the machine resets used capsule counter (with the used capsule drawer removed) <u>this delay applies only if the relevant alarm signal is shown.</u> After this time the warning or the alarm signal is cancelled. Values: 0 - 255 seconds
	1.2.10. Contrast Default: 35		To set the display contrast Values: 20 - 50
	1.2.11 Brightness Default: 150		To set the display brightness Values: 30 - 255
1.3. Stand-by	1.3.1. Activate? Default: No		“Yes” enables energy saving mode.
	1.3.2. Stand-by delay Default: 60		- When the machine is in standby mode, it switches off automatically after the defined time has elapsed following the last use. - When the machine is in standby mode, the boiler temperature is reduced after the defined time has elapsed Values: 5 - 240 Minutes

1.4. Cup warmer	1.4.1. Activate? Default: No		“ Yes ” enables operation of the cup warmer plate (only for models equipped with a cup warmer plate)
1.5. Security	1.5.1. Password Default: 0000		Set of the menu access password (4 values)
1.6. Factory preset	1.6. Factory preset Default: No		“ Yes ” enables the reset to the default values (factory preset values)

6.5. Table of service menu

1. Service menu		Press ENTER to access the service menu	
Password	Digital password	Preset default Default: 0000	Enter the previously stored password (4 digits) for accessing the password function
2.1. Date and time	2.1.1. Time		Set time (hours and minutes)
	2.1.2. Date	2.1.2.1. Day	Set day
		2.1.2.2. Month	Set month
		2.1.2.3. Year	Set year
	2.1.2.4. Day of the week	Set the day of the week	
2.2. Audit	2.2.1. Total from reset	2.2.1.1. Total from reset	Number of product type 1,2,3 and 4 dispensed since the last Reset
		2.2.1.2. Prod.1 from reset	Number of product type 1 (espresso) dispensed since the last Reset
		2.2.1.3. Prod.2 from reset	Number of product type 2 (long coffee) dispensed since the last Reset

2.2. Audit	2.2.1. Total from reset	2.2.1.4. Prod.3 from reset	Number of product type 3 (manual dose) dispensed since the last Reset
		2.2.1.5. Prod.4 from reset	Number of product type 4 (double espresso) dispensed since the last Reset
		2.2.1.6.Last reset	(Read only) Date and time of the last Reset
		2.2.1.7.Reset audit Default: No	“Yes” deletes all values regarding the last Reset
	2.2.2. Total from Init	2.2.2.1.Total from Init	(Read only) Number of product type 1,2,3 and 4 dispensed since the last initialisation
		2.2.2.2.Prod.1 from Init	(Read only) Number of product type 1 (espresso) dispensed since the last initialisation
		2.2.2.3.Prod.2 from Init	(Read only) Number of product type 2 (long coffee) dispensed since the last initialisation
		2.2.2.4.Prod.3 from Init	(Read only) Number of product type 3 (manual dose) dispensed since the last initialisation
		2.2.2.5.Prod.4 from Init	(Read only) Number of product type 4 (double espresso) dispensed since the last initialisation
		2.2.2.6.Prod. Last init	(Read only) Date and time of the machine initialisation
2.3. Brew unit wash	2.3.1. Brew unit wash Default: No		“Yes” starts the brew unit wash cycle
2.4. Rinsing	2.4.1. At the start? Default: Yes		“No” deactivates the rinse cycle at every machine start-up. Notes: The rinse cycle is performed at every machine start-up only if the temperature of the boiler is lower than 50°C; the cycle starts once the warm-up phase has completed.
	2.4.1. Every 24 hours? Default: Yes		“No” deactivates the rinse cycle every 24 hours.

2.5. Descaling	2.5.1.Do it now Default: No		“Yes” starts the descaling cycle
	2.5.2. Last descaling		(Read only) Date and time of last descaling cycle
	2.5.3. Remaining quantity		(Read only) Water quantity (litres) to be dispensed before the next descaling cycle
2.6. Filter cleaning	2.6. Filter cleaning Default: No		“Yes” start the wash cycle of the filter softener
2.7.Errors	2.7.1. Error log	2.7.1.1. Display errors with up/down buttons	(read only) The 5 most recent errors are displayed. It is possible to access if there is at least one error in the list 0 = oldest error 5 = last error
	2.7.2. Log reset Default: No		“Yes” clears the list of recent errors
	2.7.3. Error reset Default: No		“Yes” clears the non self-resolving “Out of service” errors
2.8.Credits	2.8.1. Warning level Default: 30		Sets the minimum number of credits to display the alarm message
2.9.Security	2.9.1.Password Default: 0000		Changes the password to access the service menu (4 digits) from the default value (0000)
2.10. Identification	2.10.1. Operator PIN Default:00000		Identifies the service provider or the operator code: Numerical value between 0 and 65535

6.6. Parameter change

Attention

When one of the machine's operational parameter is changed, consider that you are changing the parameters set by the manufacturer for the optimal performance of the machine.

All the editable parameters can be changed in the following way.

When the page showing the parameter to be changed is displayed press the "OK" button.

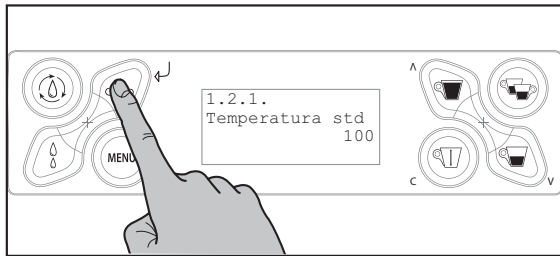

The value is made editable and under the digit to be changed the " " symbol appears..

Press one of the two buttons to change the value.

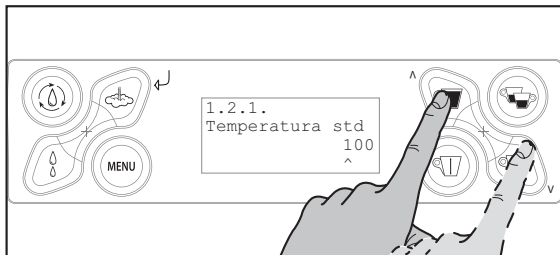

When the desired value is shown, press "OK" to confirm it.

The value is stored and the next digit is made editable, change the digit by " " or " " if necessary. Press "OK" to confirm.

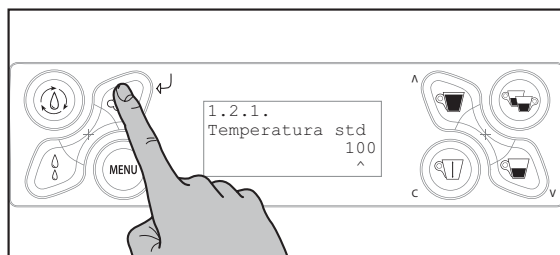

When the last digit is changed, press "OK" to confirm. The " " symbol disappears and the parameters become active only upon exit the programming mode.

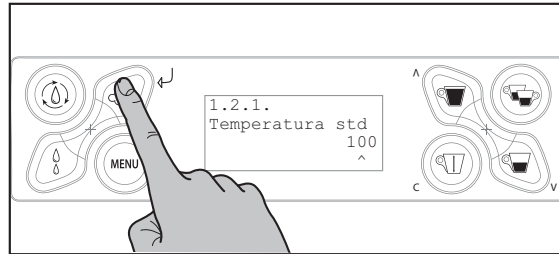

6.7. Exiting programming mode

To exit the programming mode the following screen should be displayed by pressing the "ESC" button.

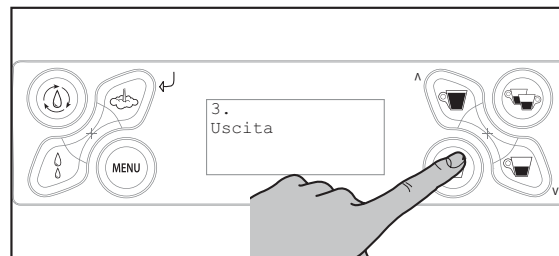

When the exit screen is displayed press the "OK" button.

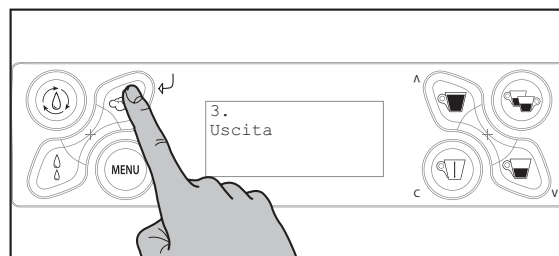

LB 2301 - LB 2302 - LB 2311 - LB 2312

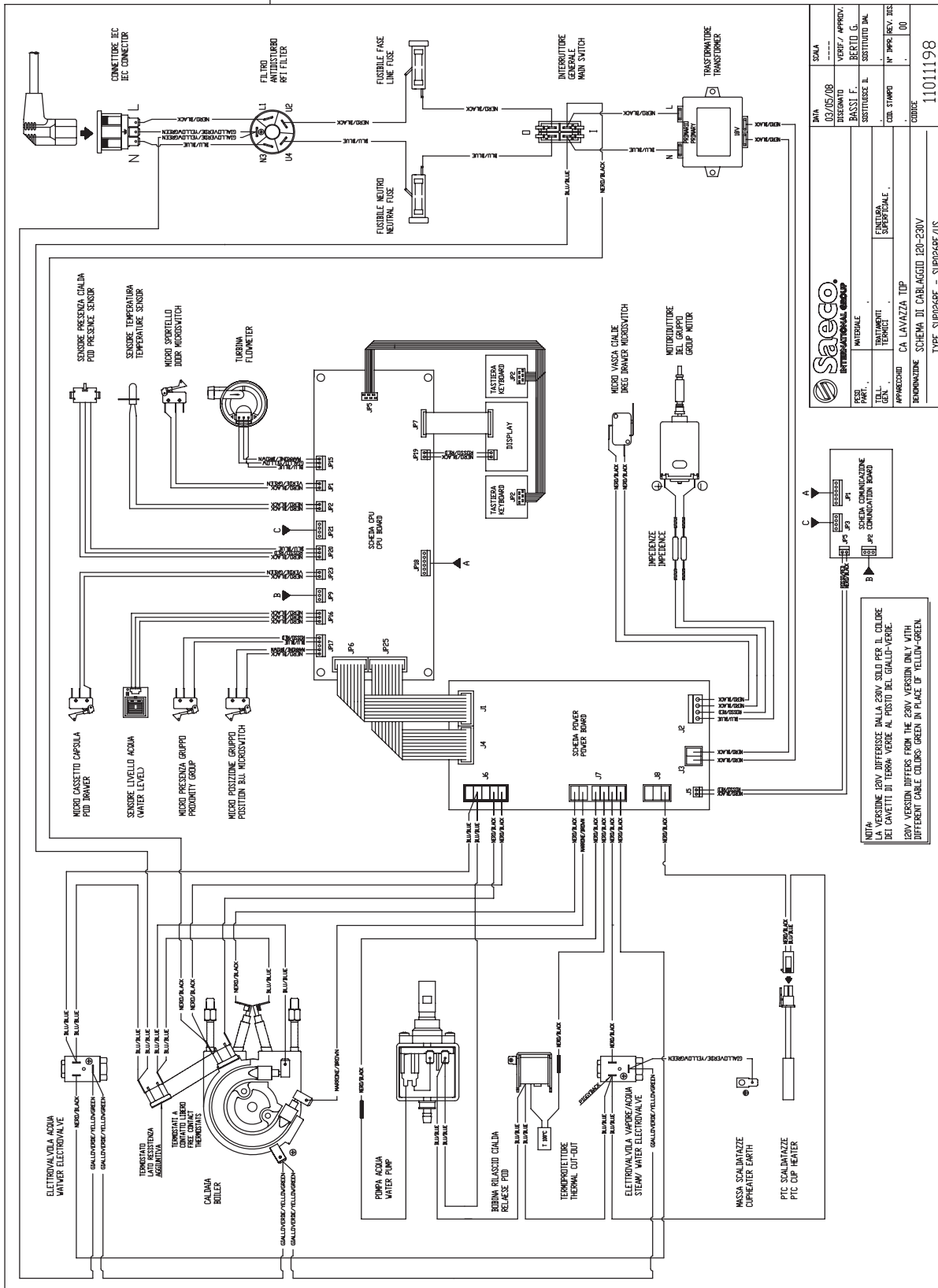

SALA		DATA	03/05/08
VERIF. / APPROV.	RECID G.	DISEGNO	BASSI F.
SOSTITUIRE IL	SOSTITUIRE IL	TELL. GEN.	MATERIALE
CON. STAMPO	NO. IMP. REV. DIS.	APPARECCHIO	CA LAVAZZA TIP
CODICE	11011198	INDICAZIONE	SCHEMA DI CARICGIO 120V-230V
TYPE SUP26RF - SUP26RF/US			

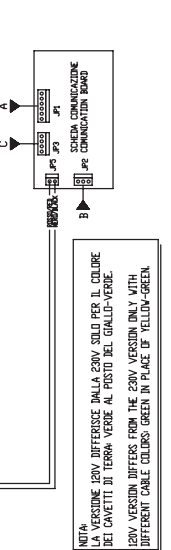

NOTA:
 LA VERSIONE 120V DIFFERISCE DALLA 230V SOLO PER IL COLORE DEL CAVETTO DI TERRA VERDE AL FUSO DEL GIALLO-VERDE.
 120V VERSION DIFFERS FROM THE 230V VERSION ONLY WITH DIFFERENT CABLE COLOR: GREEN IN PLACE OF YELLOW-GREEN.

8. TROUBLESHOOTING

8.1. Test mode

Attention

Be careful when the test mode is activated; during this operating mode some safety device set by the manufacturer are by-passed.

This function allows the correct operation of the internal components, which are electrically activated, to be checked.



Note

The brew unit will work only if the used capsule drawer is inserted correctly and the service door is closed.

8.2. Access to test mode

- Turn the machine on (bipolar switch on the rear): when the hourglass appears, press the UP button (long coffee).
- At the test mode entry the software version, installed on the machine, is displayed.
- The test mode has 6 levels, each level allows only certain functions to be controlled; this configuration allows a more functional management of the tests that is possible to carry out on the machine.
- As soon as the pressed button is released, the first level test appears on the display.
- Pressing the enter button (2) the next test mode level is reached.

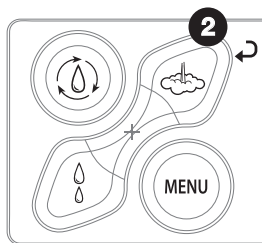

LB 2300 Single cup

Line 1: Displays the test mode level

Line 2: Displays microswitches/sensors

Line 3: Displays the pressed button

Line 4: Displays the value of the machine component

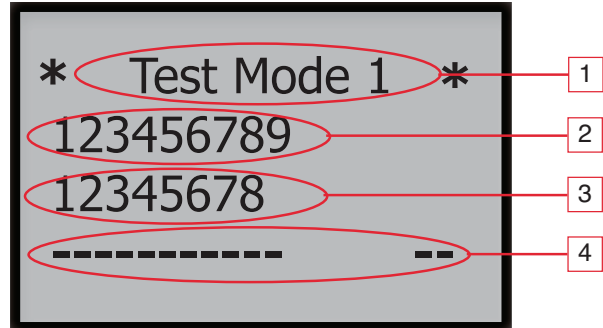

LINE 2

- 1) Microswitch of the brew unit in working position (up)
- 2) Microswitch of the brew unit in resting position (down)
- 3) Microswitch of the brew unit presence
- 4) Microswitch of the used capsule drawer
- 5) Microswitch of the capsule presence
- 6) Microswitch of the capsule loading tray
- 7) Sensor of the water level
- 8) Magnet of flowmeter turbine
- 9) Microswitch of the front panel

LINE 3

- 1) Language button
- 2) ENTER button
- 3) Manual dispensing (ESC) button
- 4) Long coffee (UP) button
- 5) Espresso coffee (DOWN) button
- 6) Stop button
- 7) Rinse button
- 8) Menu button

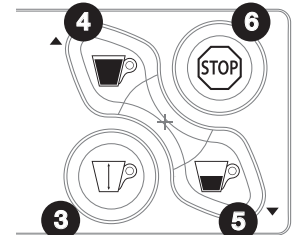
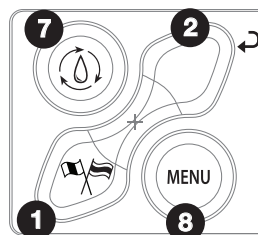

LB 2301 - LB 2311 Single cup with steam

- Line 1:** Displays the test mode level
- Line 2:** Displays microswitches/sensors
- Line 3:** Displays the pressed button
- Line 4:** Displays the value of the machine component

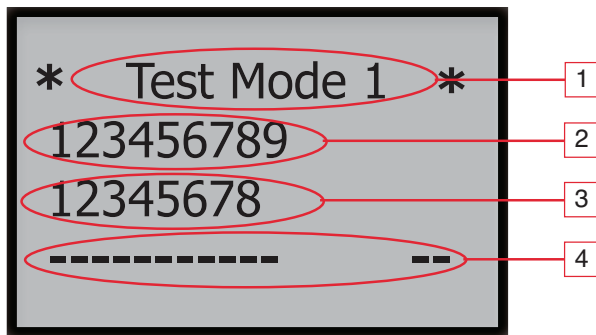

LB 2302 - LB 2312 Double cup with steam

- Linea 1:** Visualizzazione livello Test Mode
- Linea 2:** Visualizzazione Micro / Sensori
- Linea 3:** Visualizzazione Tasto premuto
- Linea 4:** Visualizzazione valore macchina

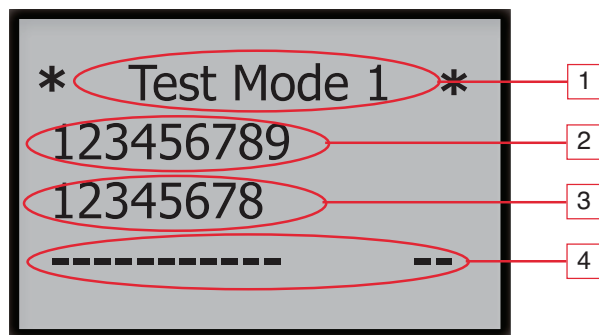

LINE 2

- 1) Microswitch of the brew unit in working position (up)
- 2) Microswitch of the brew unit in resting position (down)
- 3) Microswitch of the brew unit presence
- 4) Microswitch of the used capsule drawer
- 5) Microswitch of the capsule presence
- 6) Microswitch of the capsule loading tray
- 7) Sensor of the water level
- 8) Magnet of flowmeter turbine
- 9) Microswitch of the front panel

LINE 3

- 1) Language button
- 2) ENTER button
- 3) Manual dispensing (ESC) button
- 4) Long coffee (UP) button
- 5) Espresso coffee (DOWN) button
- 6) Stop button
- 7) Rinse button
- 8) Menu button

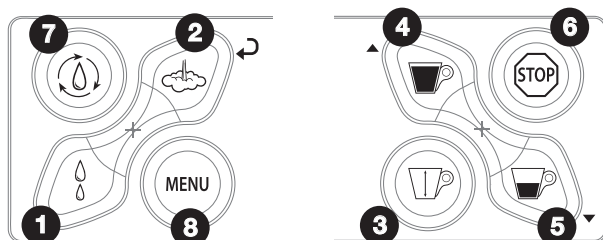

LINE 2

- 1) Microswitch of the brew unit in working position (up)
- 2) Microswitch of the brew unit in resting position (down)
- 3) Microswitch of the brew unit presence
- 4) Microswitch of the used capsule drawer
- 5) Microswitch of the capsule presence
- 6) Microswitch of the capsule loading tray
- 7) Sensor of the water level
- 8) Magnet of flowmeter turbine
- 9) Microswitch of the front panel

LINE 3

- 1) Hot water button
- 2) Steam (ENTER) button
- 3) Manual dispensing (ESC) button
- 4) Long coffee (UP) button
- 5) Espresso coffee (DOWN) button
- 6) Double dose button
- 7) Rinse button
- 8) Menu button

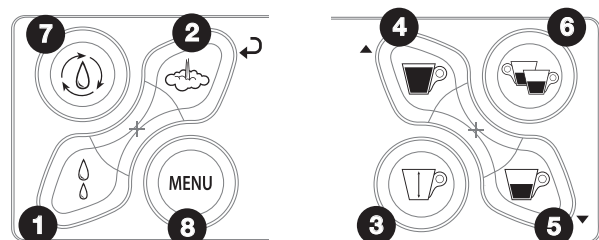

TEST MODE 1

In this level the operation of the brew unit and the capsule release coil are tested

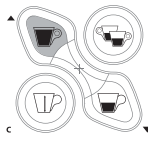

By pressing **UP** the gear motor drives the brew unit to the upper position (working position).
Upon reaching this position, on the **line 2** of the display, the number **1** will appear.

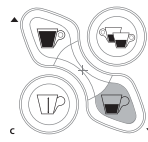

By pressing **DOWN** the gear motor drives the brew unit to the lower position (resting position).
Upon reaching this position, on the **line 2** of the display, the number **2** will appear.
During the motion of the brew unit, the force acting on it, will appear on the **line 4**.
The number displayed does not correspond with a measure unit but is proportional to the current used by the motor.

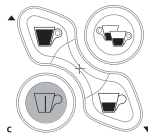

Press **CANCEL** to activate the coil of the capsule release.



By pressing the enter button the next test mode level is reached (level 2).

TEST MODE 2

In this level the operation of the pump, the coffee solenoid valve, the steam solenoid valve are checked (the last two only for De Luxe model)

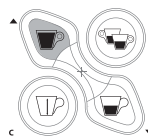

By pressing **UP** the steam solenoid valve is activated

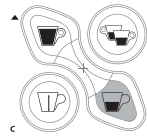

By pressing **DOWN** the coffee solenoid valve is activated.

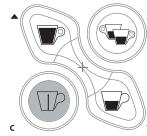

Press **CANCEL** to activate the pump; on the **line 4** of the display the flow rate in pulse/sec will appear.



By pressing the enter button the next test mode level is reached (level 3).

TEST MODE 3

In this level the operation of the boiler heating elements is checked.

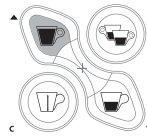

By pressing **UP** the main heating element of the boiler is activated.

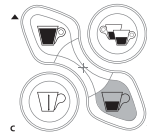

By pressing **DOWN** the secondary heating element of the boiler is activated.

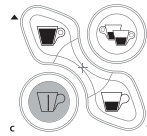

Some faults are indicated regarding the temperature sensor as (sensor short circuit or sensor open circuit)
The temperature is always displayed.

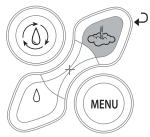

By pressing the enter button the next test mode level is reached (level 4).



By pressing the enter button the next test mode level is reached (level 6).

TEST MODE 4

In this level the value of the net frequency that the machine has detected at starting, is displayed at the bottom on the right side.

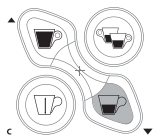

By pressing **DOWN** the cup warmer is activated.
(Only for the machines equipped with cup warmer).

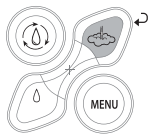

By pressing the enter button the next test mode level is reached (level 5).

TEST MODE 5

In this level the display contrast can be changed.



By pressing **UP** the display contrast is increased.

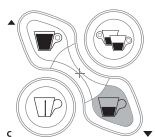

By pressing **DOWN** the display contrast is diminished.
(The number shown in the fourth line of the display, indicates the set contrast value).

TEST MODE 6

In this level it is possible to change the brightness of the display backlight.

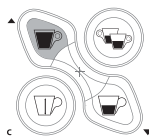

By pressing **UP** the display luminosity is increased.

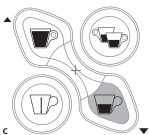

By pressing **DOWN** the display luminosity is diminished.
(The number shown in the fourth line of the display, indicates the set brightness).

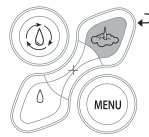

By pressing the enter button you go back to test mode level 1.

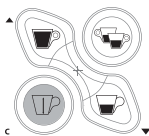

Keep the button (C) pressed to exit the test mode.

8.3. Troubleshooting

This chapter indicates the troubleshooting procedures to follow when a fault is signalled by the machine.

Error code	What has happened	Possible cause	Where to find the cause
11	After the product selection the capsule did not fall into the brew unit within a timeout of 1 sec. (only after the 5th attempt) The alarm can be reset by switching the machine off	The capsule is deformed and/or not up to standard	Replace the capsule with a new one and/or up to standard
		The release unit is broken or malfunctioning	The mechanism of the release unit is broken or blocked
			Release unit overheating
			The Triac on the power board is broken
			CPU board is broken
			The wiring is interrupted
12	Zero Crossing miss The alarm can be reset by switching the machine off	Unsuitable net frequency (Neither 50Hz, nor 60Hz)	Check the electric net
		Unspecified voltage (Too low)	Check the electric net
		The power board is broken	Power board
		The CPU board is broken	CPU board
13	Problem with capacitive keyboard	Capacitive keyboard	The fault is on one of the two capacitive keyboards
			Wires that connect the keyboards to the CPU board

Error code	What has happened	Possible cause	Where to find the cause
21	The water circuit is interrupted The alarm can be reset by switching the machine off	The machine does not detect the water flow in the circuit	The sensor of the water level is broken
			The sensor of the turbine is broken
			The pipe of the water circuit is interrupted, clogged or disconnected
			The brew unit is occluded
			The solenoid valve is occluded or broken
			The pump is broken or interrupted
			The thermal switch of the pump is off
			The boiler is occluded
			The Power board (TRIAC) is broken
Command from CPU board			
27	Alarm of the water circuit	The water flow in the hydraulic circuit is blocked	<ul style="list-style-type: none"> - Check the clogs - Check the water level - Check the operation of the water level sensor - Check the turbine operation
51	Short circuit of the sensor	Short circuit of the temperature sensor	Check the temperature sensor

Error code	What has happened	Possible cause	Where to find the cause
52	The temperature sensor is not connected	The temperature sensor is broken	
		The wire of the temperature sensor is disconnected	
	Room temperature for installation or storage is too low	Room temperature too low	
53	The temperature is too high	The boiler temperature is inexplicably increased	The Triac on power board is broken.
			The CPU board is broken (it does not control the power board)
54	Boiler temperature error	Boiler temperature out of control (e.g. the boiler is on and the temperature does not increase)	The boiler safety thermostat is activated
			The boiler heating unit is broken
			The Triac on the power board is broken
			The temperature sensor does not work properly
			The CPU board is broken (it does not command the power board)
			The temperature sensor is disconnected from the boiler
Da 61 a 68	EEprom error	The CPU board is broken or badly connected	
Da 71 a 78	EEprom error	The CPU board is broken or badly connected	

Error code	What has happened	Possible cause	Where to find the cause
81	Maximum effort for brewing. The alarm can be reset by switching the machine off	The motor has exceeded the maximum effort allowed to take the brew unit to the dispensing position (automatically performed only after the second)	The capsule is blocked on the brew unit
			The brew unit is jammed or blocked
			The previous capsule has not been ejected
			Gears blocked or sticking
82	Maximum effort for resting The alarm can be reset by switching the machine off	The motor has exceeded the maximum effort allowed to take the brew unit to the resting position	The capsule is blocked on the brew unit
			The brew unit is jammed or blocked
			Gears blocked or sticking
83	Out of maximum time for dispensing The alarm can be reset by switching the machine off	The brew unit has not been shifted to the dispensing position within the time predetermined by the manufacturer	The gear motor power is insufficient and not appropriate
			The microswitch for working position is broken or disconnected
			The motor of the gear motor does not work properly or it is broken
			The CPU board does not work properly
			The Power board does not work properly (TRIAC)
			The gears are broken

Error code	What has happened	Possible cause	Where to find the cause
84	Out of maximum time for dispensing The alarm can be reset by switching the machine off	The brew unit has not been shifted to the resting position within the time predetermined by the manufacturer	The gear motor power is insufficient and not appropriate
			The microswitch for working position is broken or disconnected
			The motor of the gear motor does not work properly or it is broken
			The CPU board does not work properly
			The Power board does not work properly (TRIAC)
			The gears are broken
85	Out of maximum time for dispensing The alarm can be reset by switching the machine off		The microswitch for resting position is broken or disconnected
86	The microswitch for resting position was activated while the brew unit was going to the working position The alarm can be reset by switching the machine off	The brew unit has exceeded the dispensing position without stopping	The microswitch for working position is broken or disconnected
			Inverted wiring on the motor of the gear motor
87	The microswitch for resting position was activated while the brew unit was going to the working position The alarm can be reset by switching the machine off	The brew unit has exceeded the dispensing position without stopping	The microswitch for working position is broken or disconnected
			Inverted wiring on the motor of the gear motor
88	The microswitch for working and resting position were activated at the same time The alarm can be reset by switching the machine off	Both the microswitches were activated at the same time	Both the microswitches are in short circuit condition
			Brew unit badly assembled
91	The maximum torque value was exceeded The alarm can be reset by switching the machine off	Indicates if the machine has exceeded the torque limit during the positioning of the brew unit to the dispensing position	

9. OPERATIONAL LOGIC

9.1. Reset of used capsule drawer

The warning message “empty used capsule drawer” occurs by means of a “coffee” product counter (20) controlled by the electronic of the machine.

The counter reset (“empty used capsule drawer” warning reset) is performed if the drawer is removed for the time set in the programming menu 1.2.9.

(Page 17)

9.2. Reserve for product end

The machine has a fixed reserve (turbine pulse) which allows the selected drinking to be ended each time the capacitive sensor detects the water in the tank; otherwise the machine shows the message “fill water tank” and does not dispense the product.

The product can be dispensed completely or partially according to the reserve compared with the programmed length of the selected product.

At the next selection the user will be asked to fill the water tank.

Example:

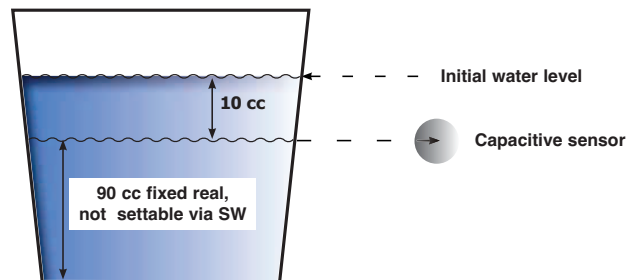

Ex: the sensor detects the water presence (+10 cc):

hypothesis 1) a product of 60 cc is selected, 50 cc of water are taken from the reserve, the product is completely dispensed, then the message “fill the tank” appears.

hypothesis 2) a product of 110 cc is selected, 90 cc of water are taken from the reserve, the product is partially dispensed (100 cc), then the message “fill the tank” appears.

hypothesis 3) a double coffee of 110 cc is selected, the first product is partially dispensed 100 cc, the message “fill the tank” appears and then the second product is completely dispensed (110 cc).

hypothesis 4) a double coffee of 40 cc is selected, both products are completely dispensed

10. RECOMMENDED TOOLS

To carry out the appliance maintenance you need the following tools:

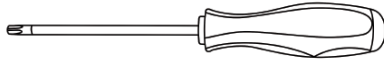

Torx screwdriver T10

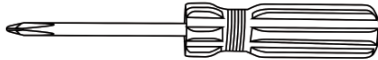

Crosshead screwdriver PH1

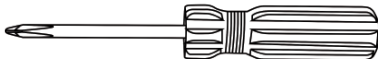

Crosshead screwdriver PH2

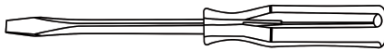

Flat screwdriver 0.8 x 4 x 80



Open ended spanner 10 mm

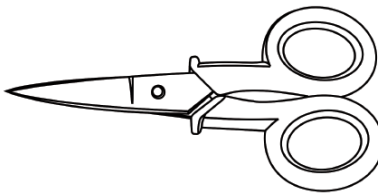

Safety scissors

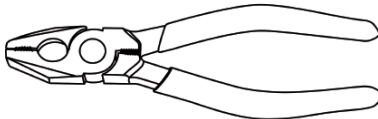

Standard pliers

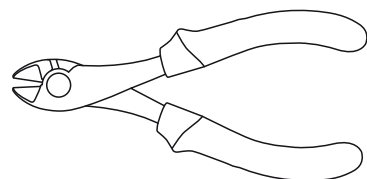

Pincers

Attention

All the mechanical connections and cables use safety faston.

If there is a faston cover, squeeze the plastic as indicated in the figure and pull

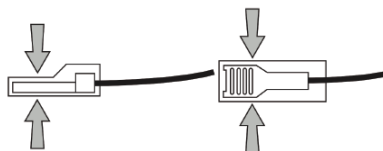

11. MOUNTING AND DISASSEMBLY OF THE MACHINE COMPONENTS

11.1. Upper body

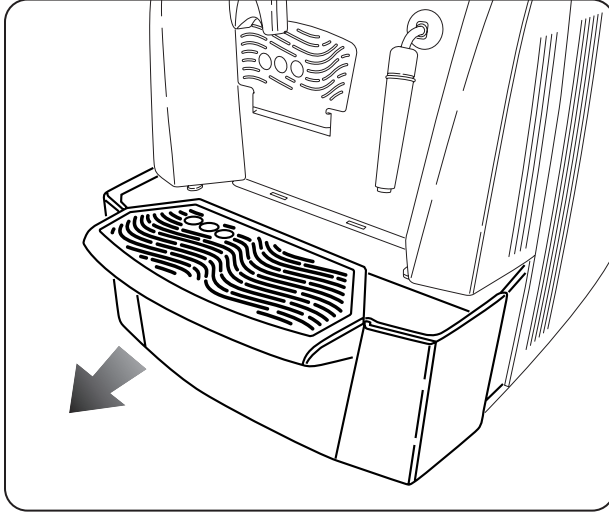

Remove the used capsule drawer; separate and dispose of the used capsule; empty the waste water.

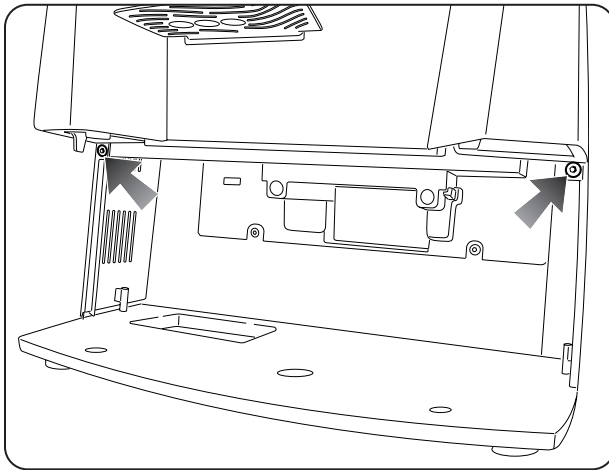

Loosen the indicated screws.

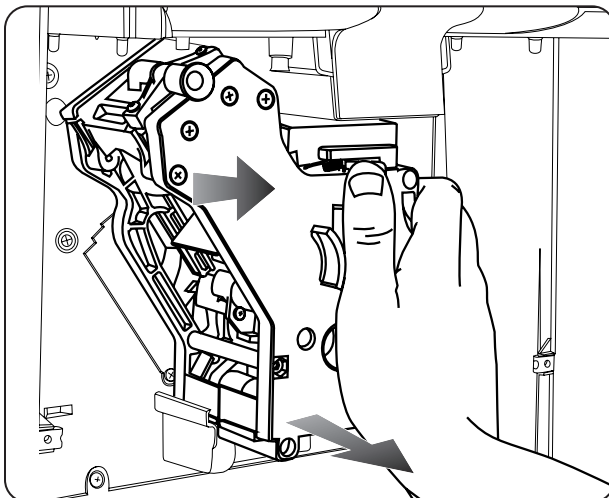

Press the "PUSH" button and remove the brewing unit from its seat.

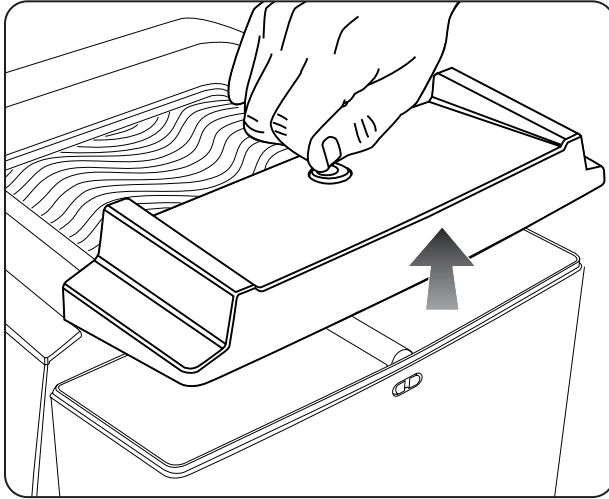

Remove the water tank lid using the key.

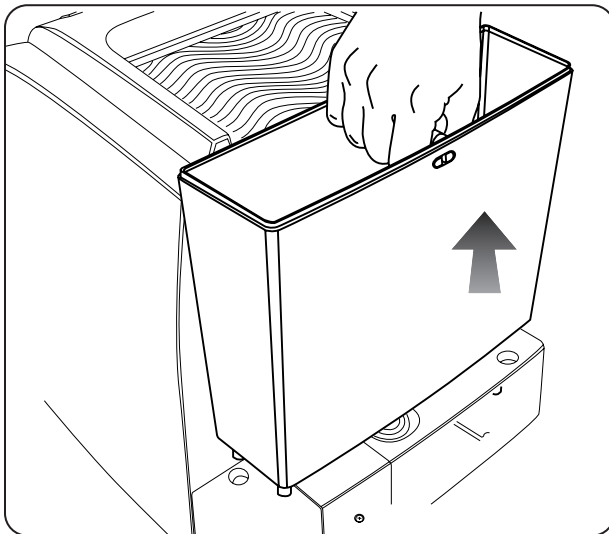

Remove the water tank by lifting it up using its handle.

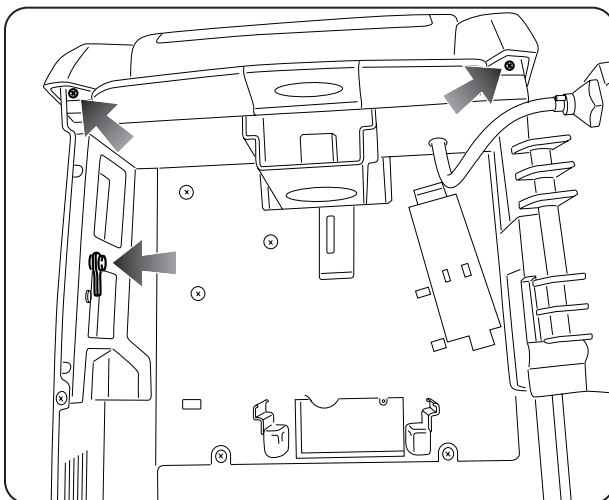

Loosen the body screws and the fixing nut of the tumbler lock.

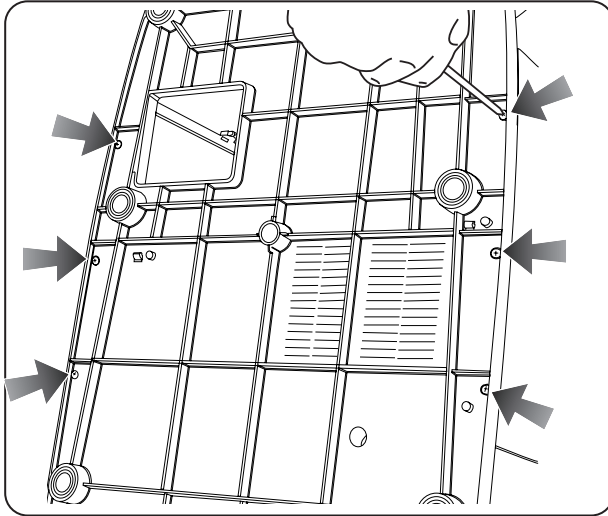

Loosen the indicated screws which fix the body to the machine bottom.

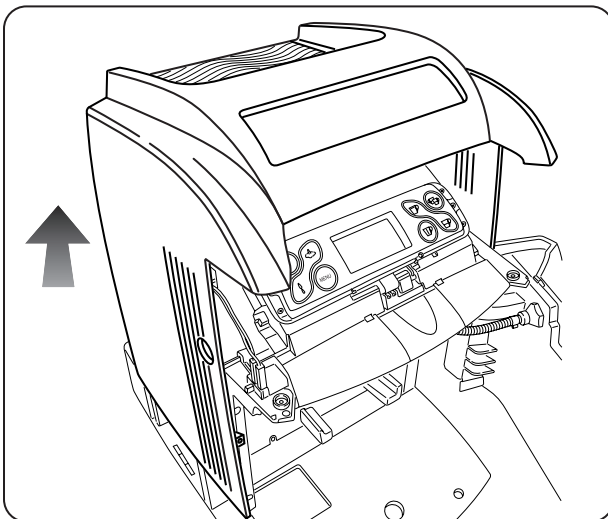

Lift the body up gently, as indicated in the figure.

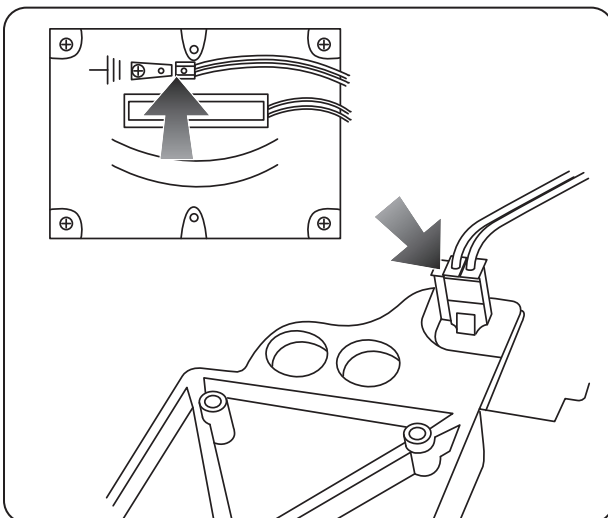

For the version equipped with cup warmer, remove the power supply connector of the cup warmer and the ground fastener connector (now the body is disengaged).

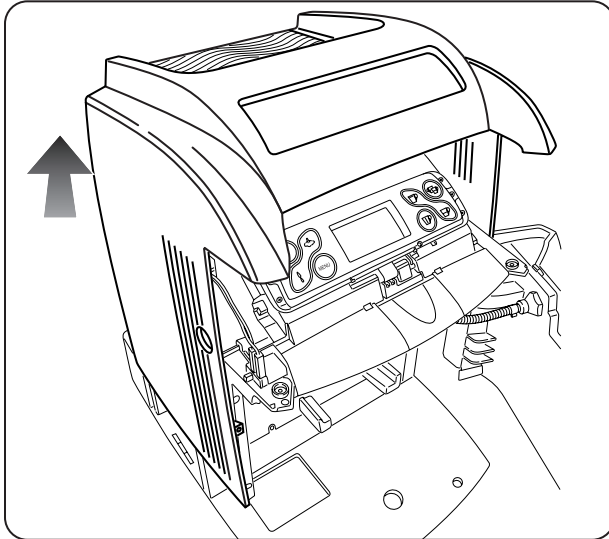

When the connectors are removed extract the body completely.

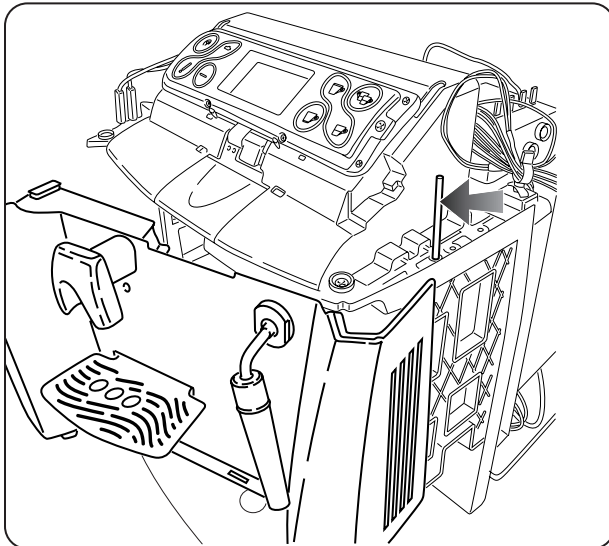

Extract the indicated pin with force to remove the front panel.

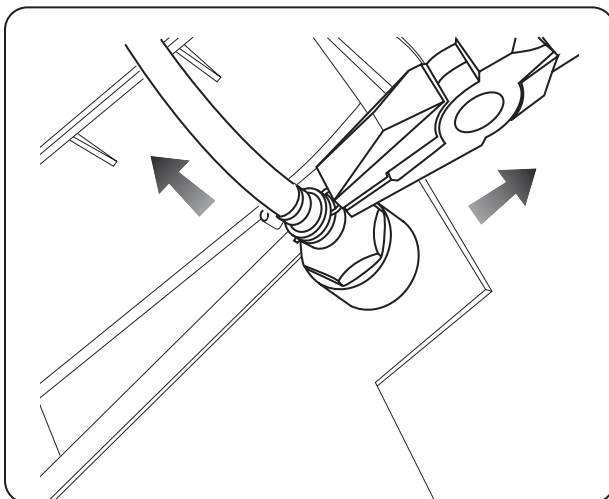

Remove the clip which fixes the steam pipe to the door and extracts the pipe from its seat.

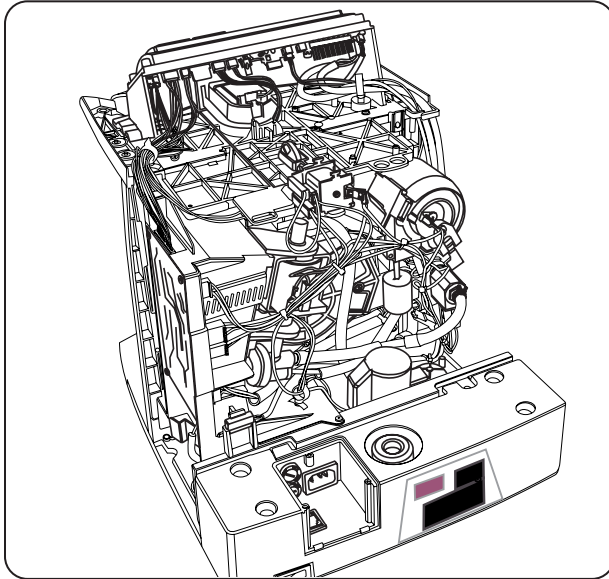

It is possible to access the internal components to check their operation.

Attention

Now the machine has no shielding; in the machine there are electrical components and component which generate heat. Be careful when operating under these conditions.

11.2. GACO gasket replacement

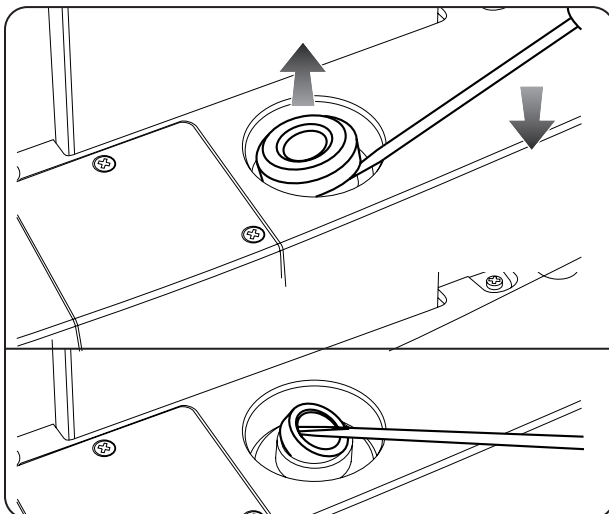

- Lever with a screwdriver to remove the gasket cover;
- Remove the gasket with a screwdriver.
- After placing the new gasket, position the cover again by hand and press until it is locked in position.

11.3. Power cord replacement

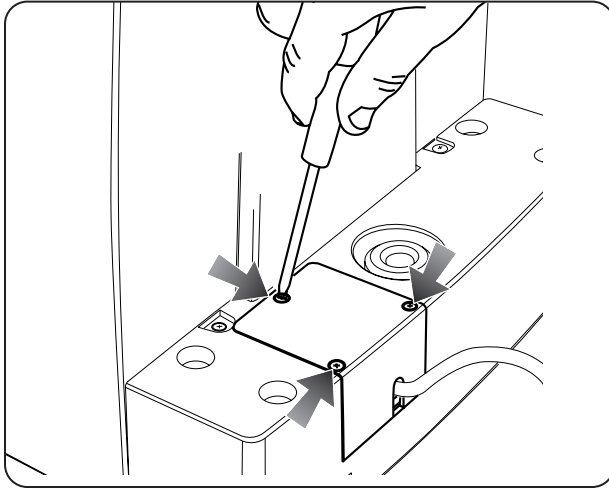

Remove the indicated screws

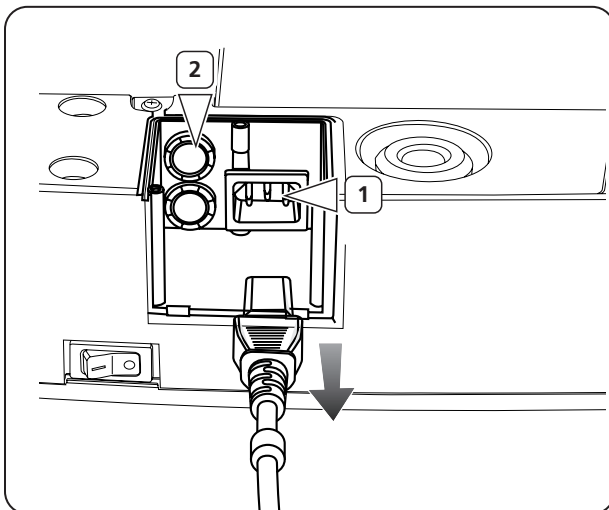

Inside the compartment there are :
1) the receptacle of the power cord
2) the fuse housing

11.4. Connector compartment

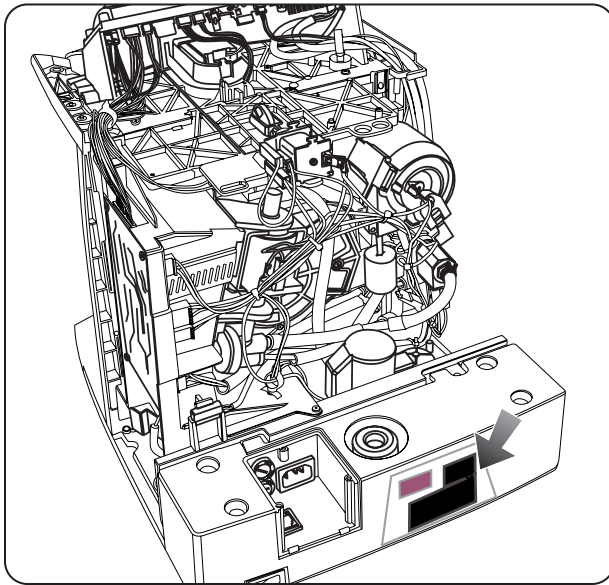

Remove the indicated screw and the black cover.

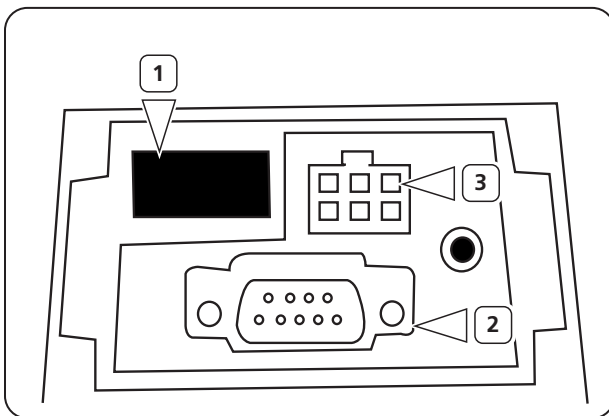

- 1) Infrared interface for diagnostic and reprogramming of the machine parameters and software.
- 2) Connector for payment systems
- 3) Serial port for P.C. for reprogramming of the machine parameters and software.

11.5. Steam pipe disassembly

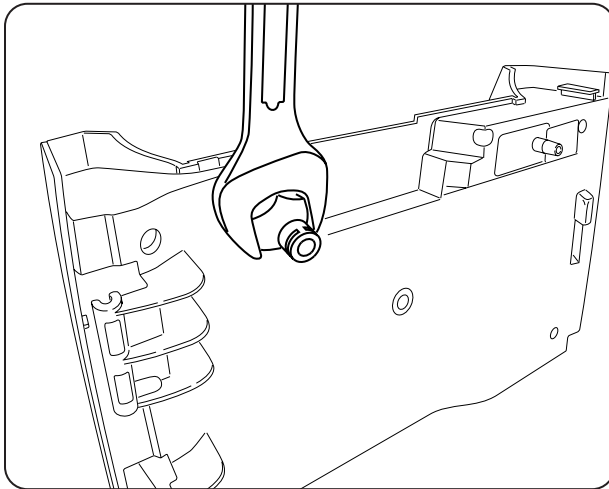

Disassemble the steam pipe by using a spanner.

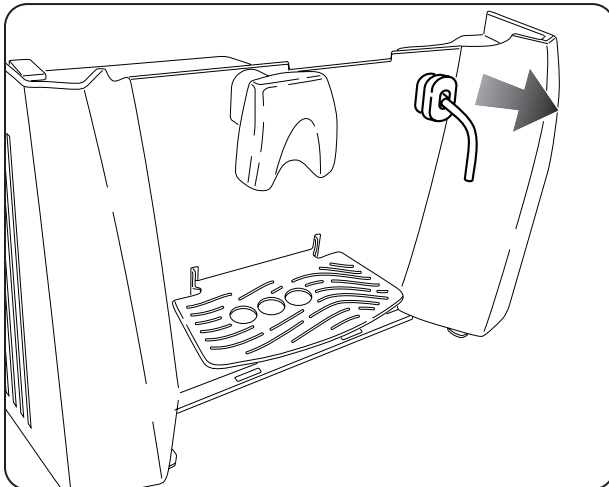

Remove the steam pipe.

11.6. Steam solenoid valve disassembly

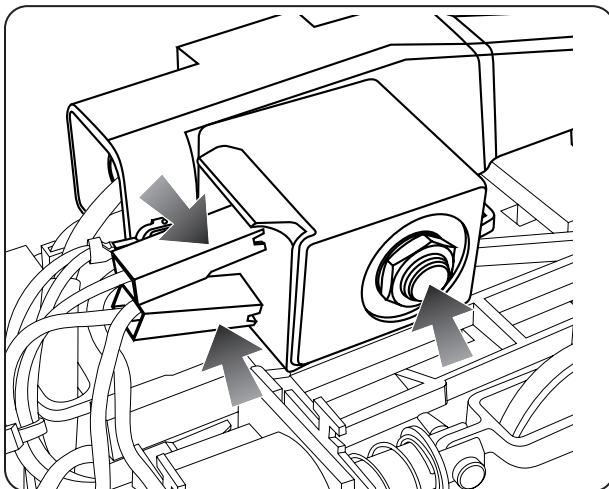

Disconnect the faston, loosen the nut and remove the coil.

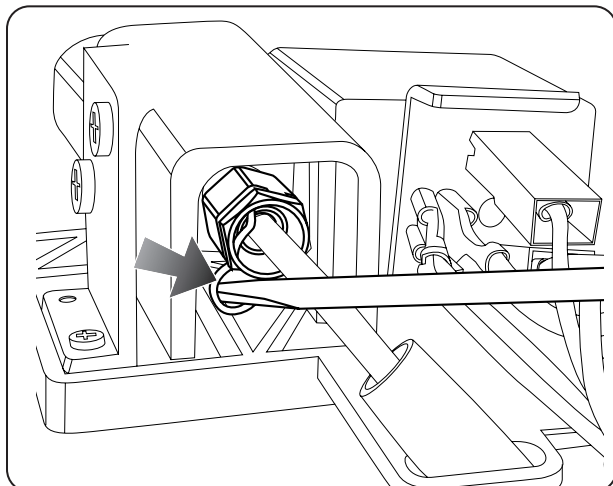

Remove the clip which fixes the pipe to the Teflon piece by using a screwdriver.

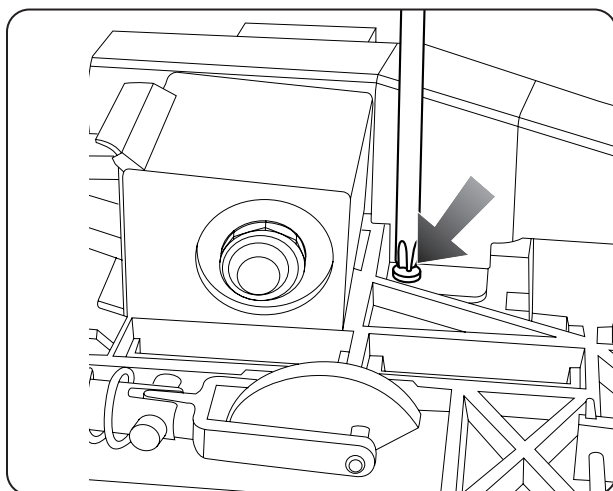

Loosen the indicated screws.

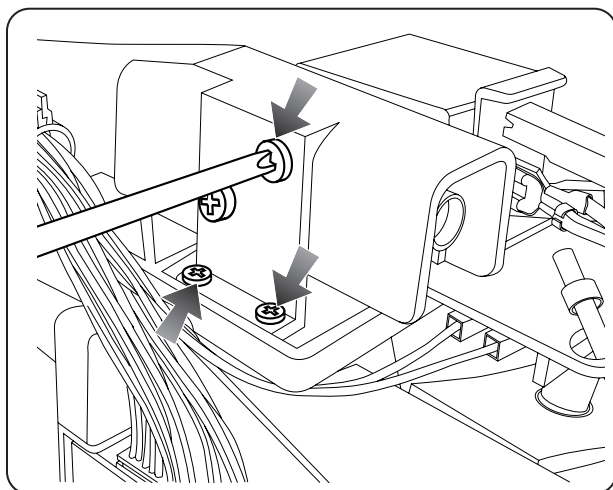

Loosen the indicated screws.

11.7. Cup warmer plate disassembly (If it is supplied)

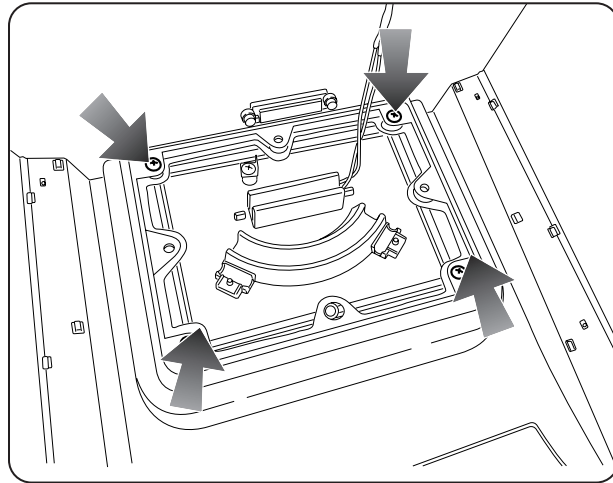

Overturn the cover and loosen the indicated screws.

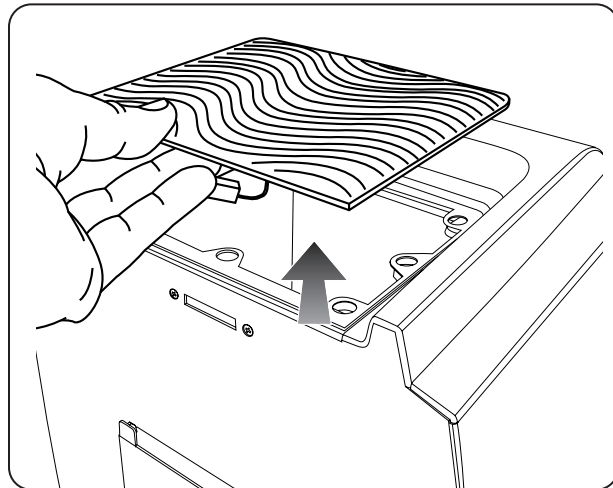

Reposition the cover correctly and remove the cup warmer plate.

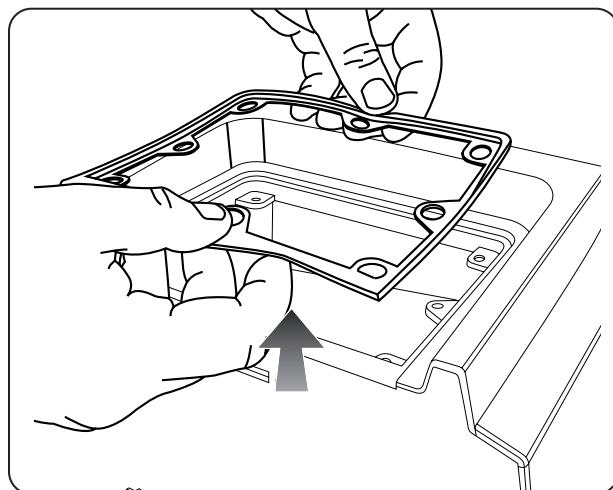

Remove the gasket and replace it if necessary.

11.8. Capsule release coil disassembly

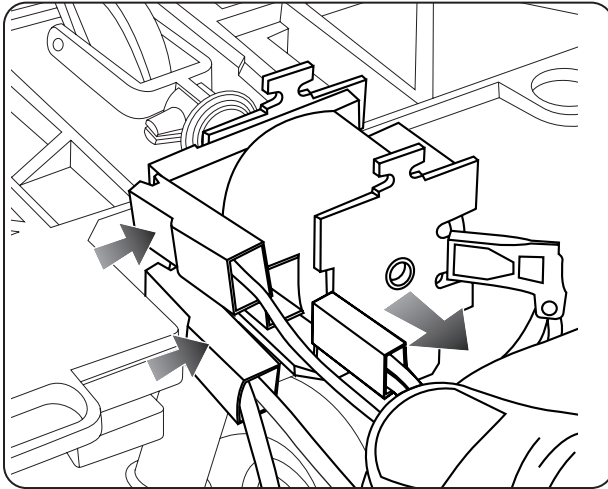

Remove the thermal protector from its seat and disconnect the electric wires.

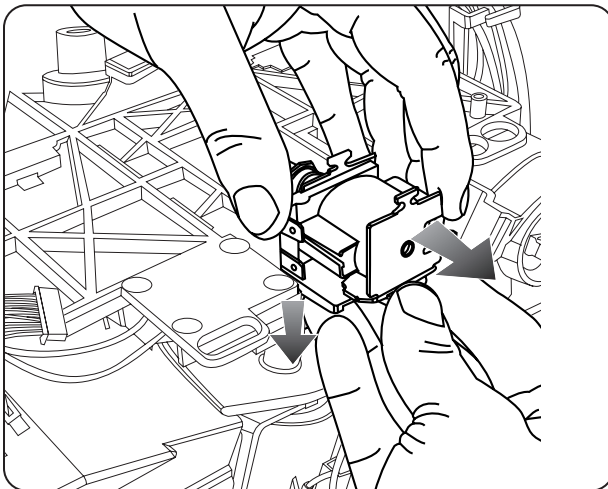

The capsule release coil should be disassembled by lowering the stop on the back.

11.9. Pump disassembly

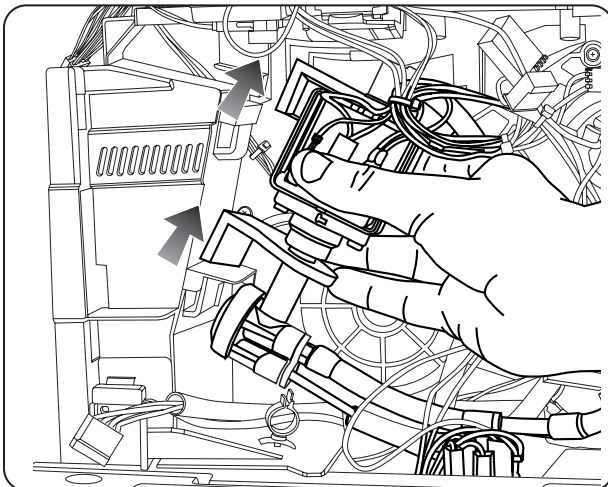

Detach the indicated supports by levering with a screwdriver and remove the electric and hydraulic connections.

11.10. Turbine disassembly

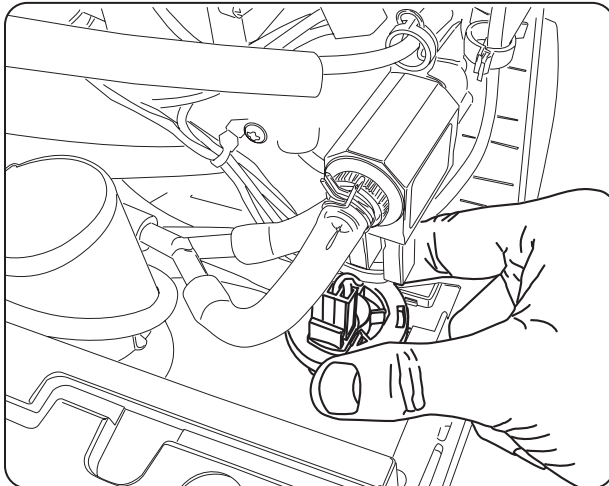

Extract the turbine by lifting it upwards.

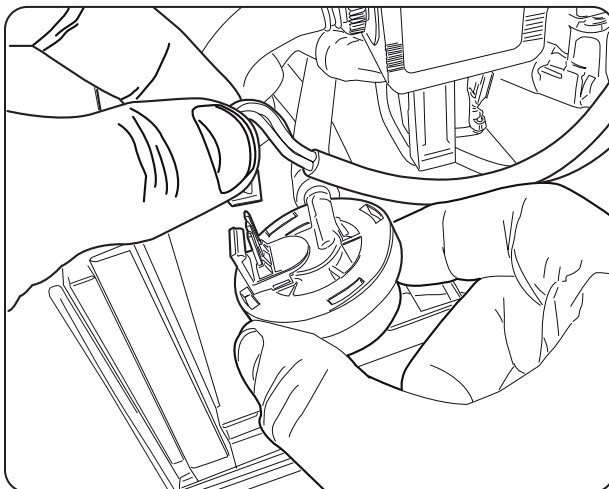

Disconnect the electrical connection.

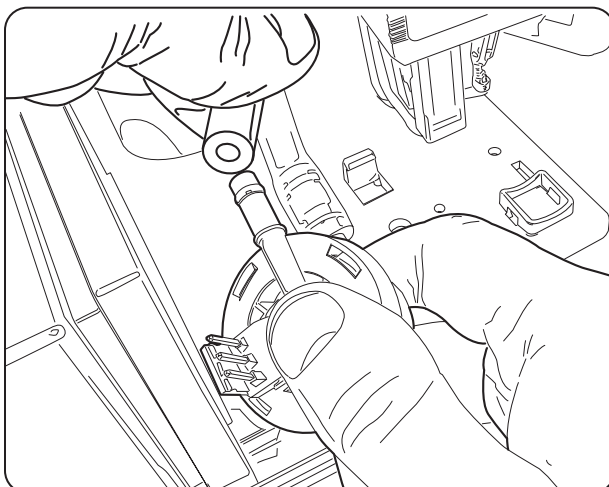

Disconnect the hydraulic connections.

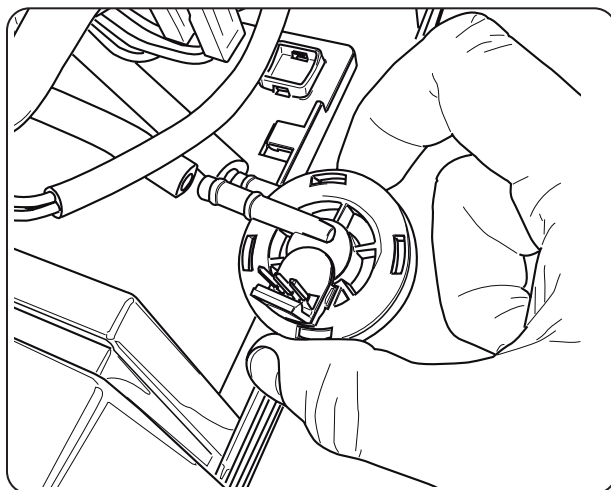

Remove the turbine from the machine.

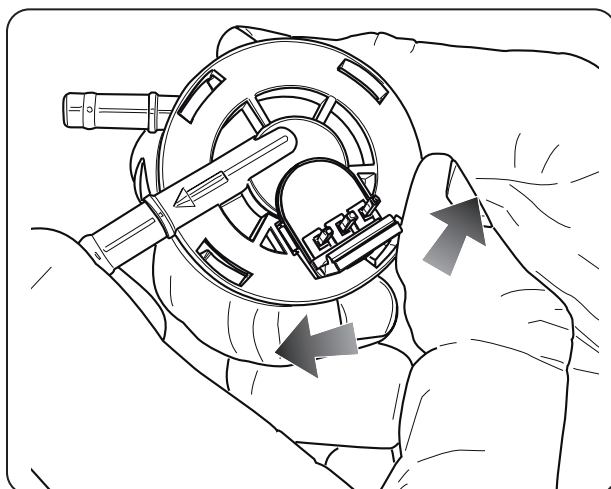

Turn the turbine top to open it.

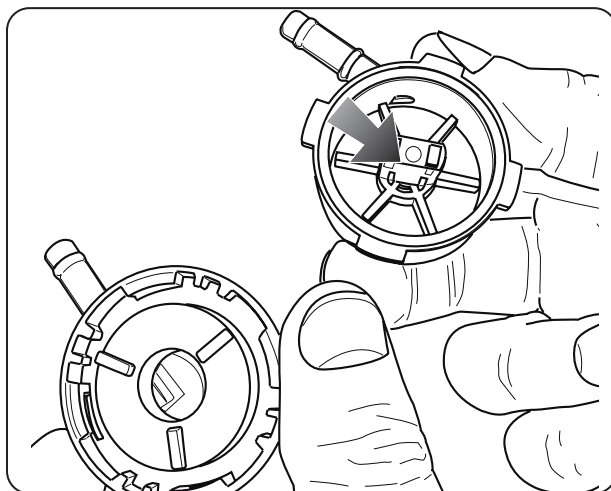

Clean the rotary section of the turbine.

11.11. Capsule release unit disassembly

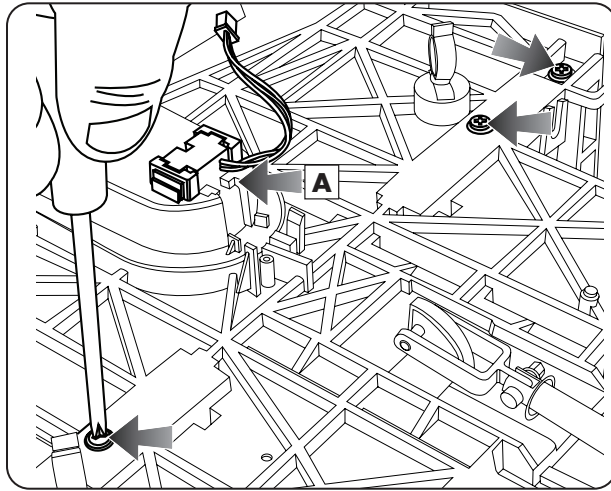

Loosen the indicated screws and remove the capsule presence microswitch.

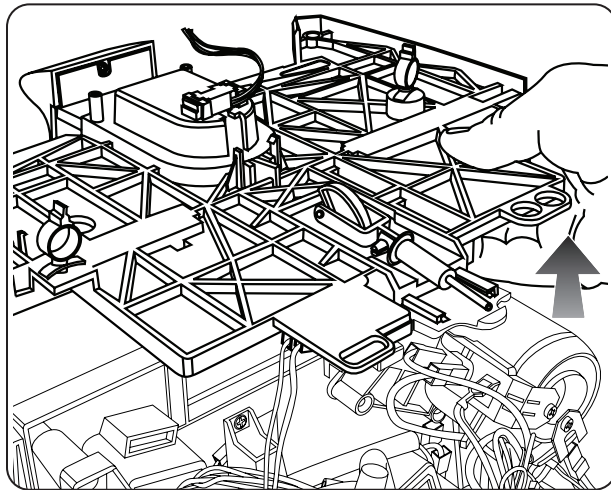

Remove the upper support from the base lifting it up.

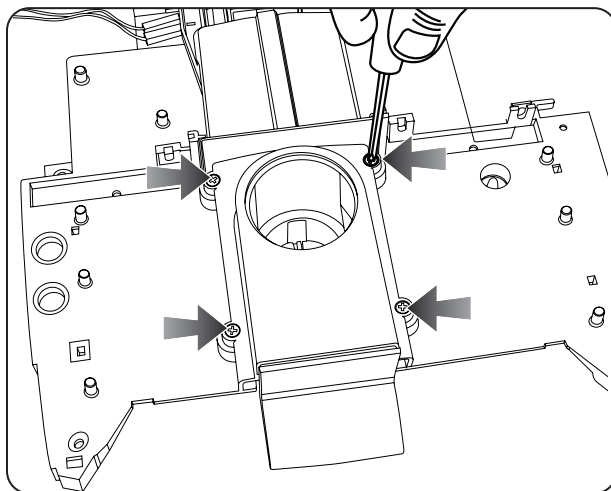

Loosen the indicated screws to access the inside of the unit.

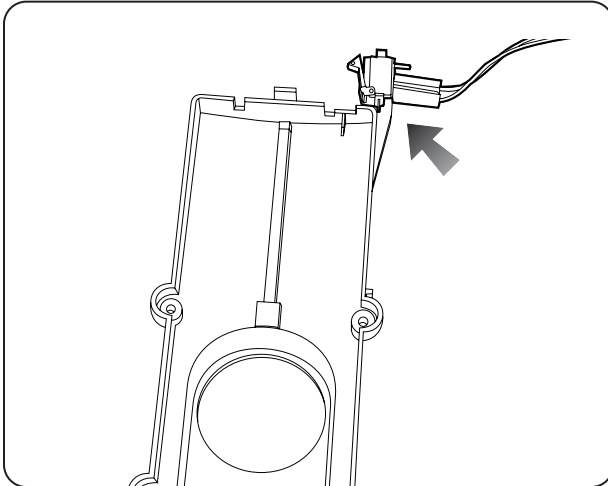

In this case it is possible to reach the microswitch that controls if the capsule loading tray is open.

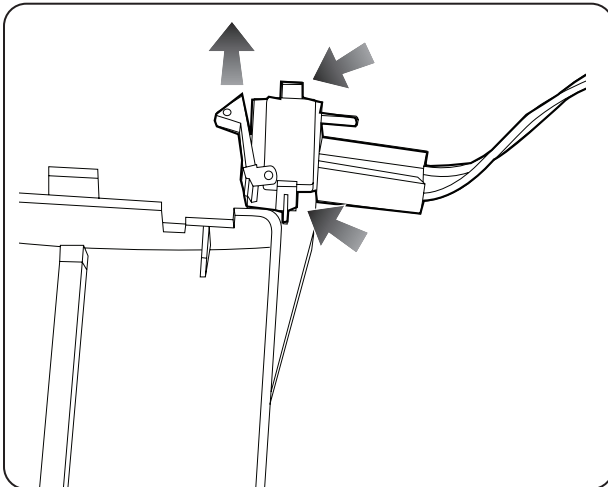

To remove the microswitch lightly widen the two stops and lift it up.

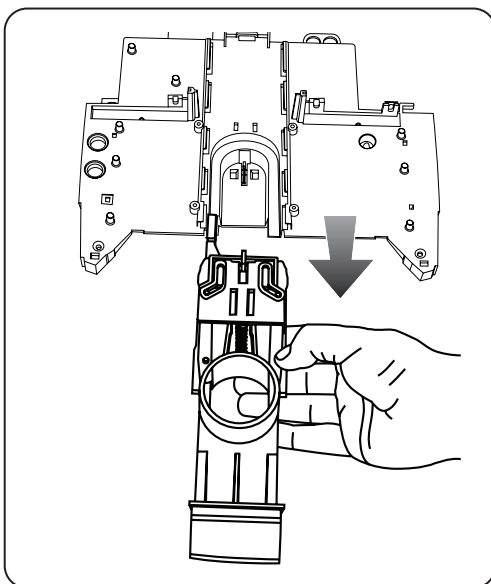

The unit can be checked by removing it from its seat as indicated in the figure.

11.12. Capacitive sensor disassembly

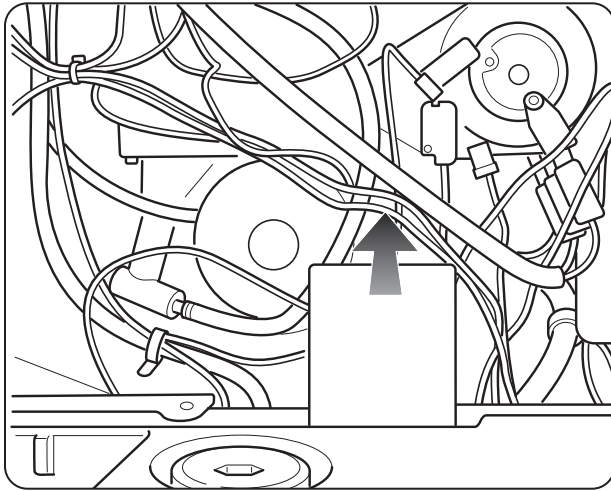

Remove the capacitive sensor from its seat.

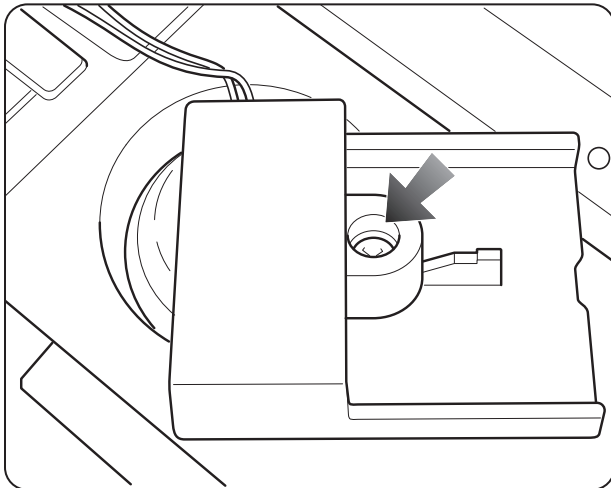

Loosen the indicated screw to access the sensor.

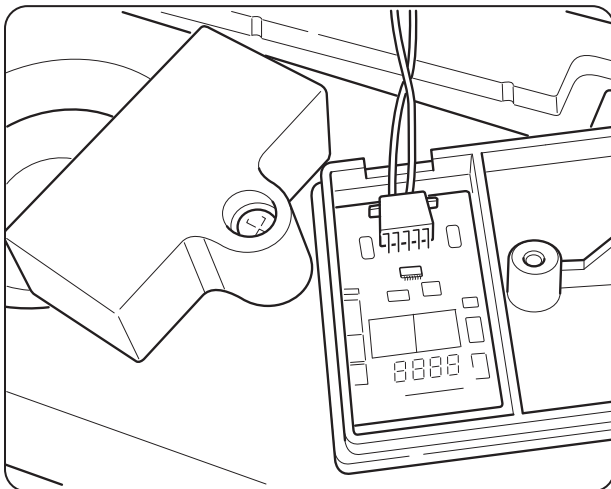

The capacitive sensor is maintained in its seat by an adhesive film.

11.13. Transformer disassembly

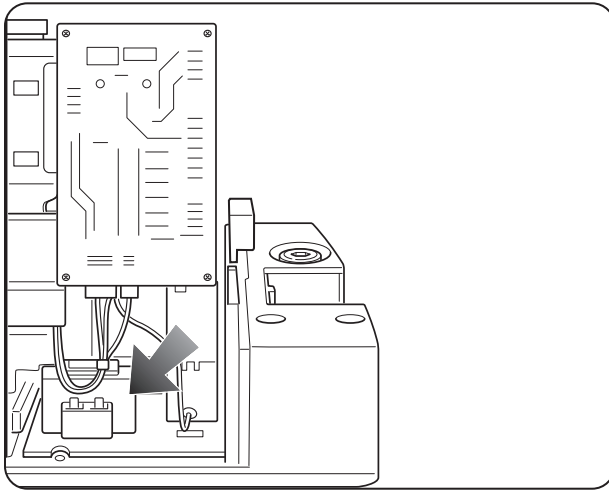

The transformer is situated under the board on the right side of the machine.

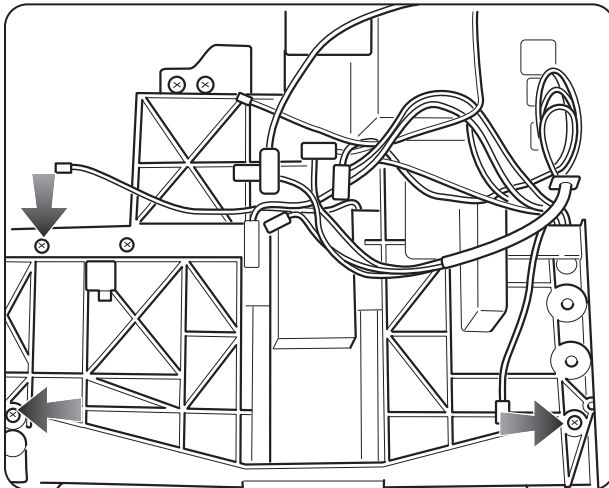

Loosen the indicated screws.

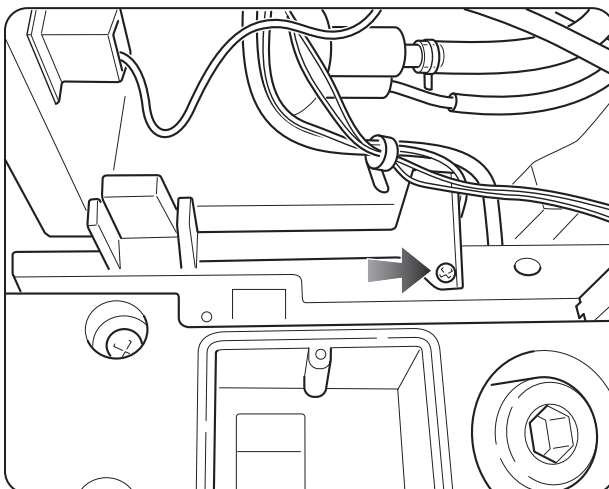

Loosen the indicated screws.

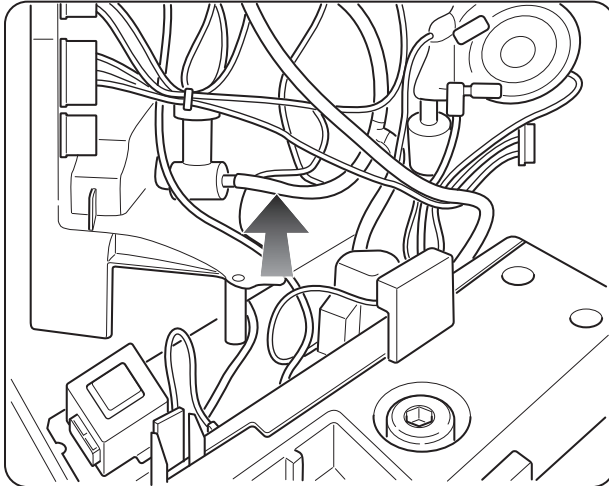

Lift the plate up.

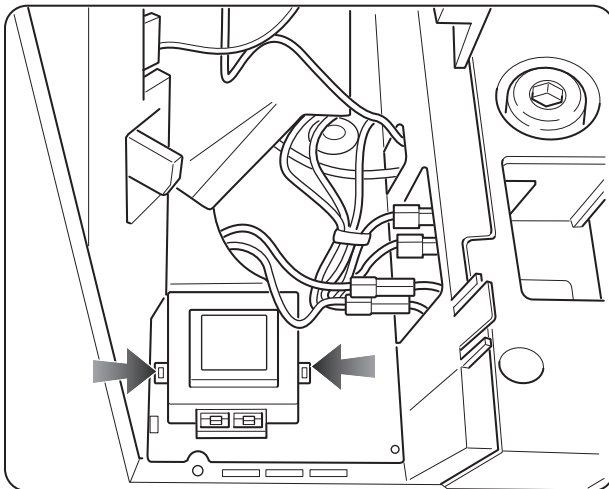

Loosen the indicated screws.

11.14. Coffee thermostat disassembly

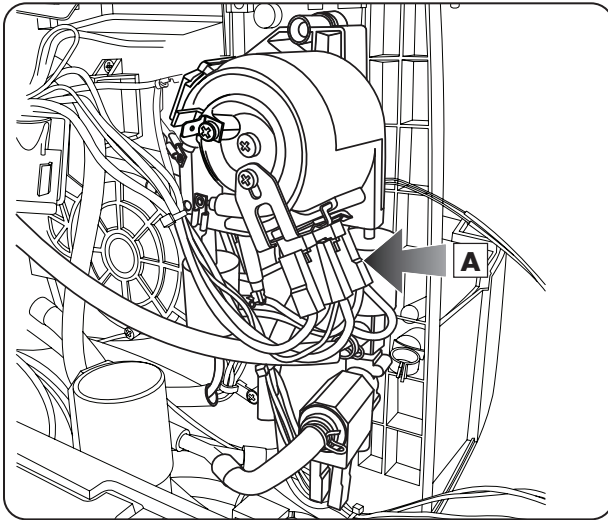

Disconnect the electric connections of the thermostats (A).

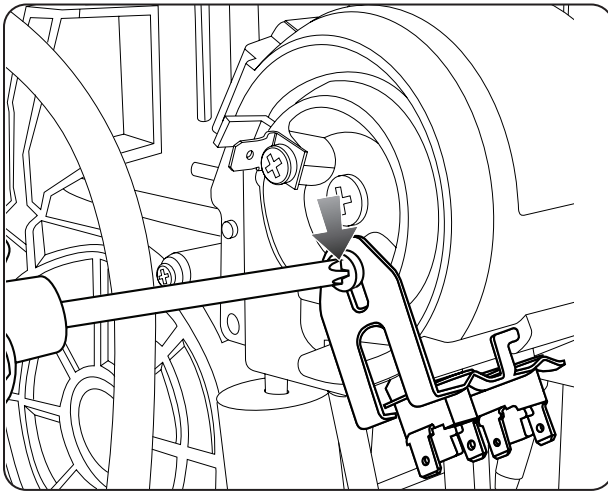

Loosen the indicated screw.

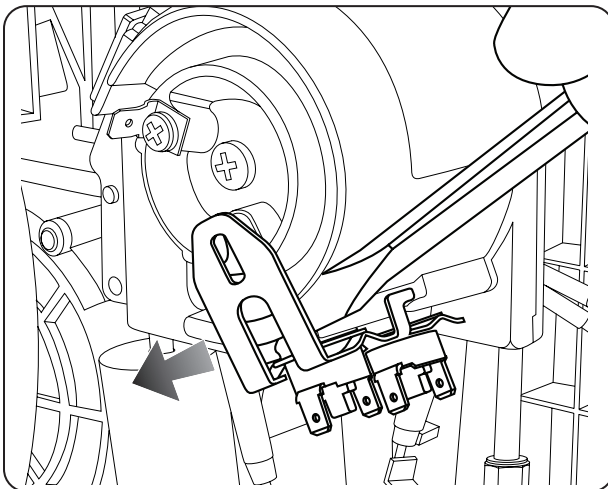

Lever with a screwdriver to disengage the retainer.

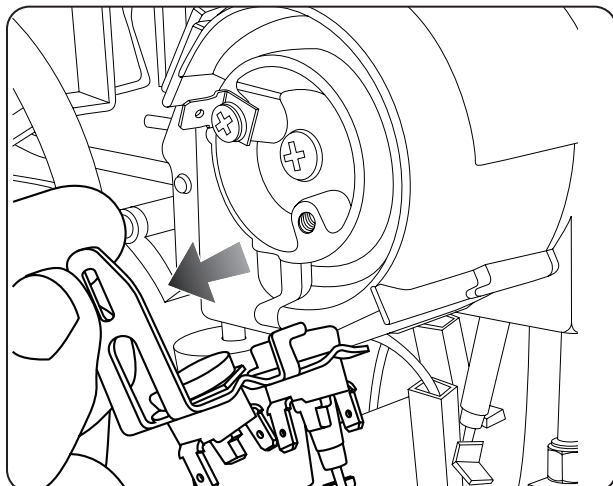

Remove the retainer and the thermostats.

11.15. Boiler disassembly

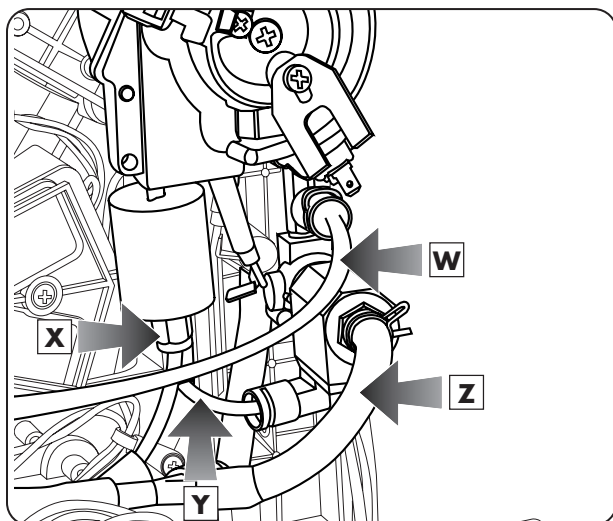

Unscrew the nut (X), remove the fork and the Teflon pipe (Y) and (W), disconnect the silicone pipe (Z).

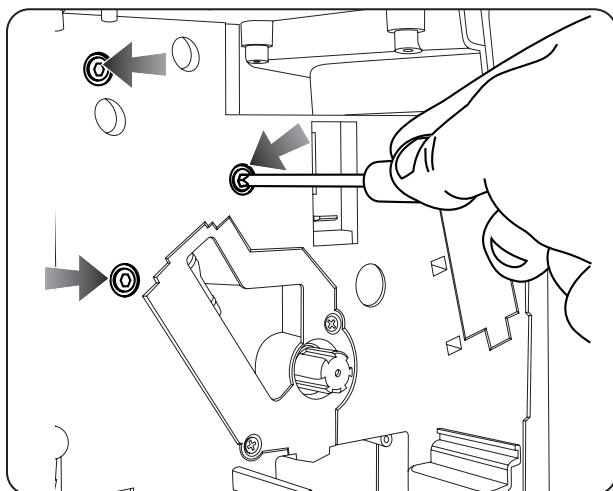

Loosen the indicated screws.

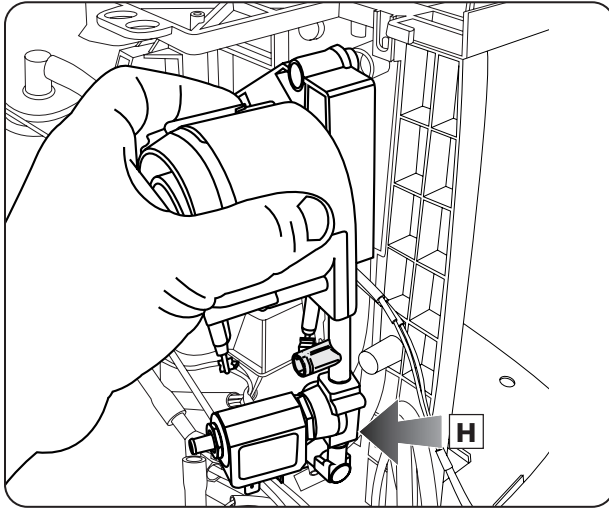

Remove the boiler and the pin from the plate.
After extracting the boiler, it is possible to disassemble the solenoid valve (H).

11.16. Gear motor disassembly

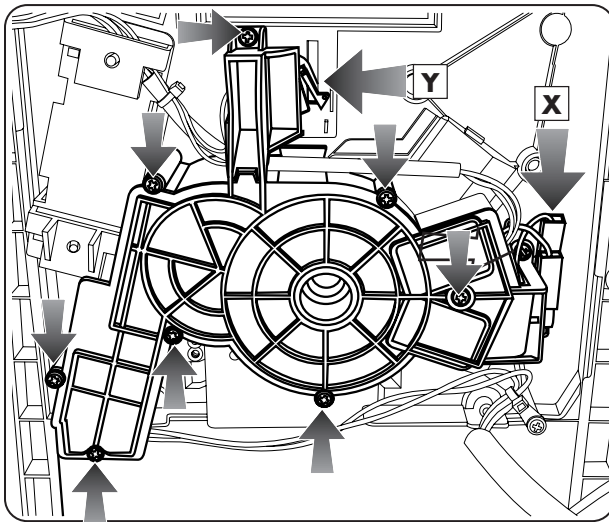

It is possible to access the microswitch of the used capsule drawer presence (X). To reach the microswitch of the brew unit presence (Y) the transparent cover must be disassembled.

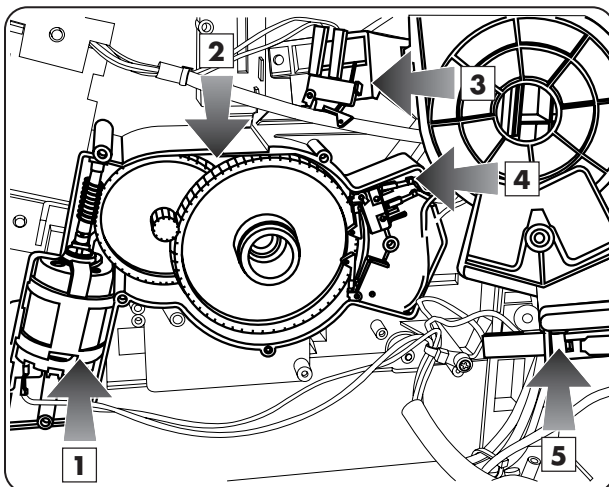

After loosening the screws, remove the cover; now you can access:

- 1 the motor
- 2 the gears
- 3 the microswitch of the brew unit presence
- 4 the microswitch of the brew unit resting position
- 5 the microswitch of the used capsule drawer presence

11.17. Perforator filter disassembly

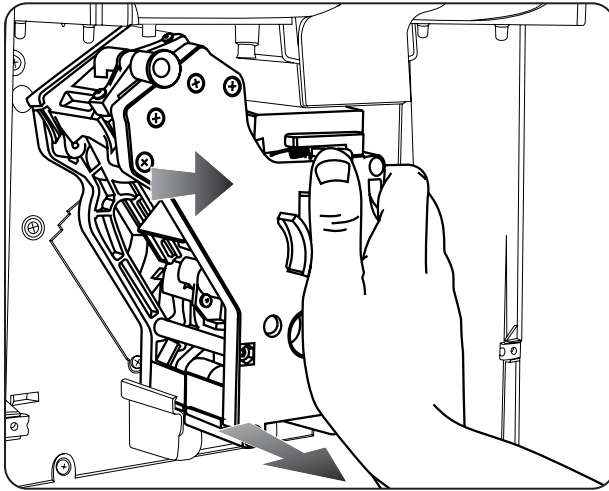

Remove the brew unit.

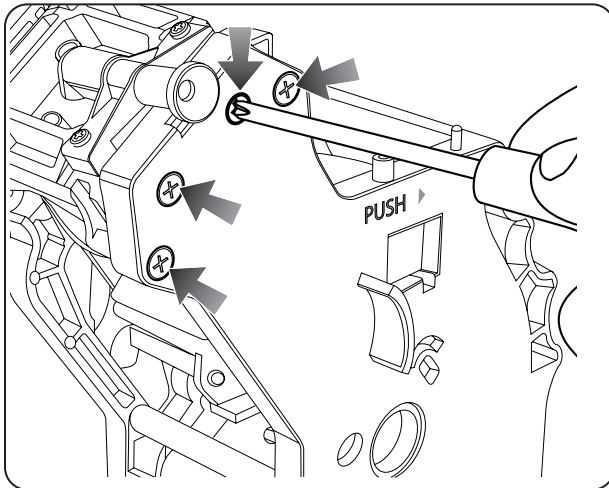

Loosen the indicated screws.

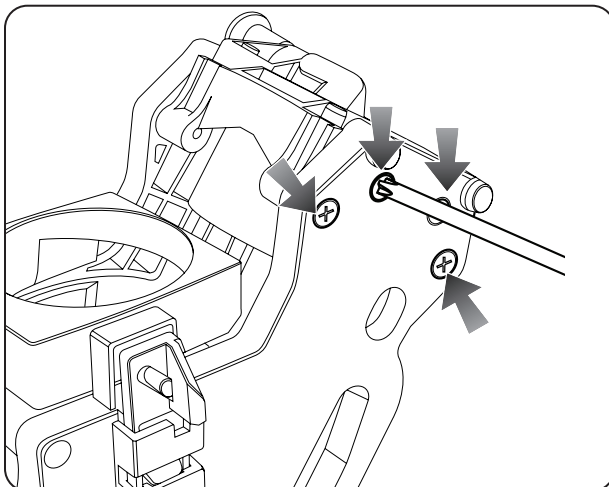

Loosen the indicated screws.

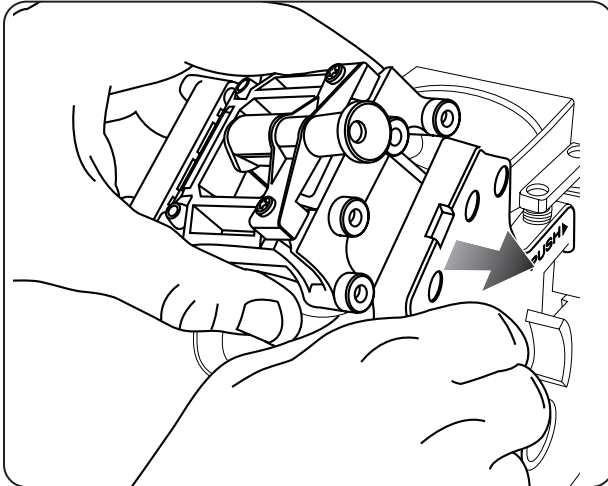

Widen lightly the brew unit sides and extract the fixed container of the coffee capsule.

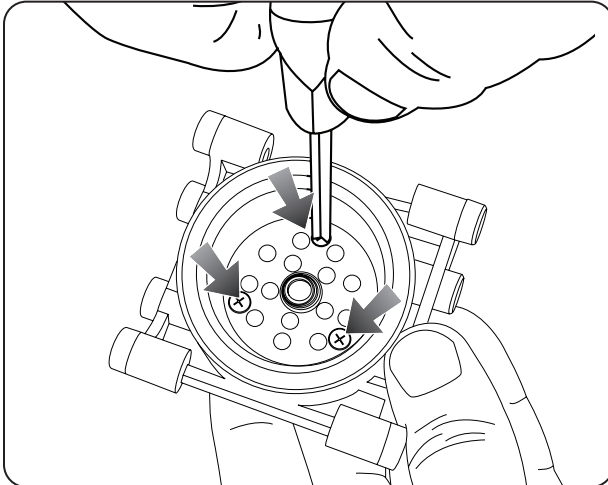

Loosen the indicated screws.

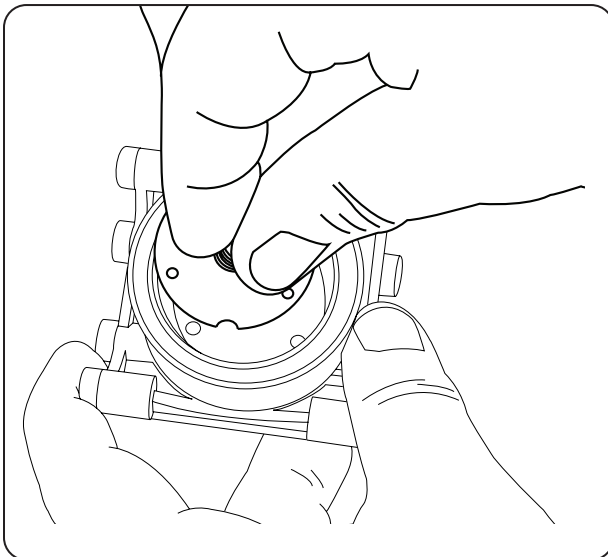

Remove the perforator.

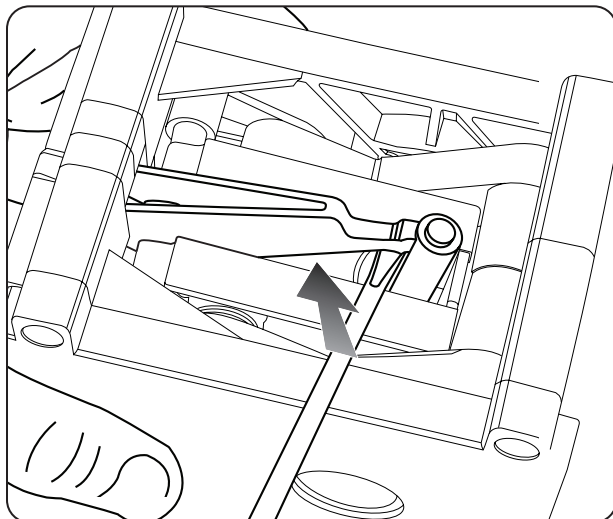

To remove the piston, lever with a screwdriver on the rod to disengage it.

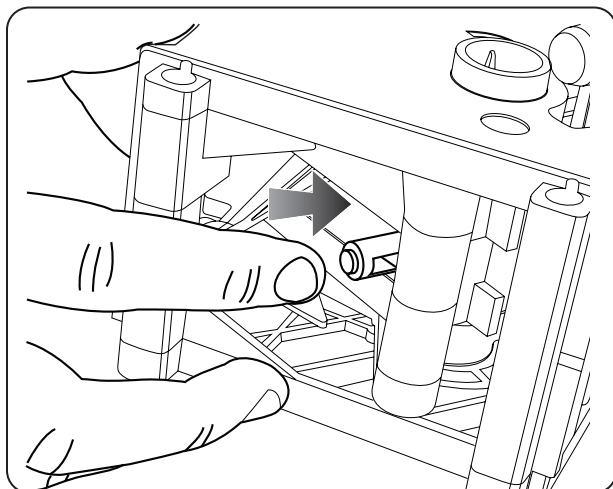

When the pin is disengaged press it with a finger to remove it from its position.

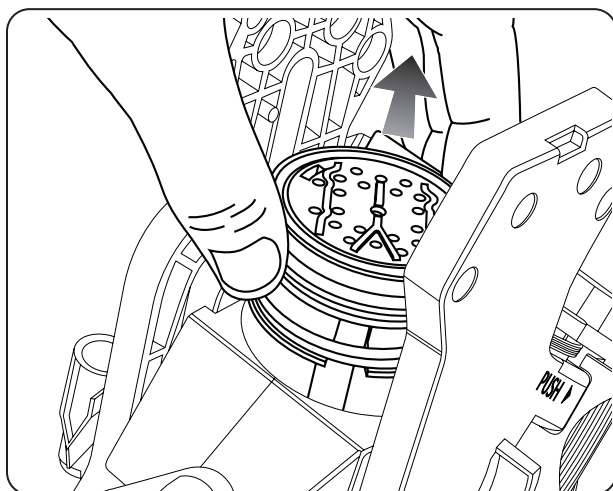

Extract the piston from the top.



Once the piston is removed the gasket can be replaced easily.

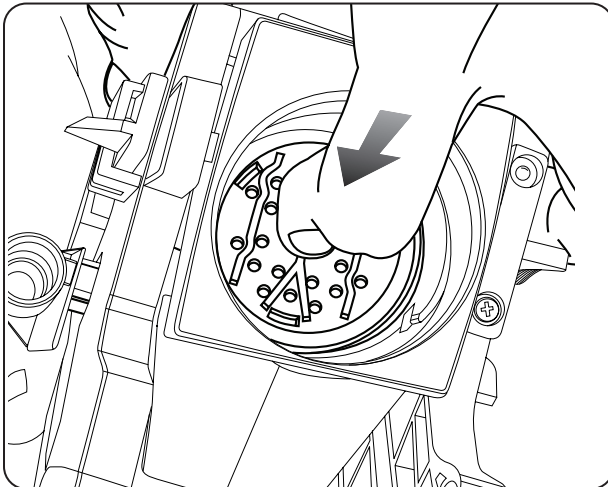

To mount the piston, insert it again in its position as indicated in the figure.

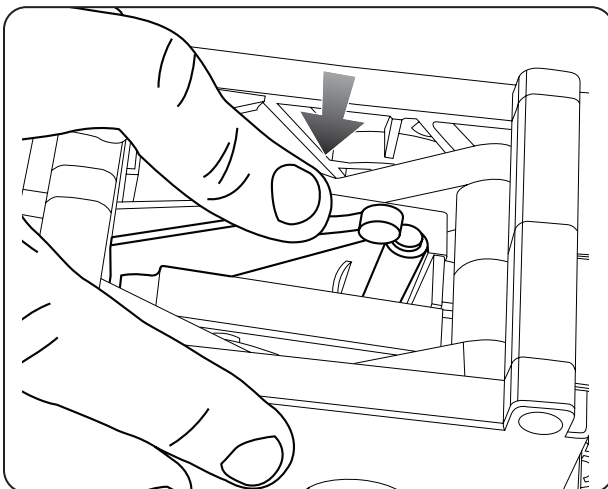

Keeping pressed the piston, press the rod into the slit of the piston until it is fixed in place.

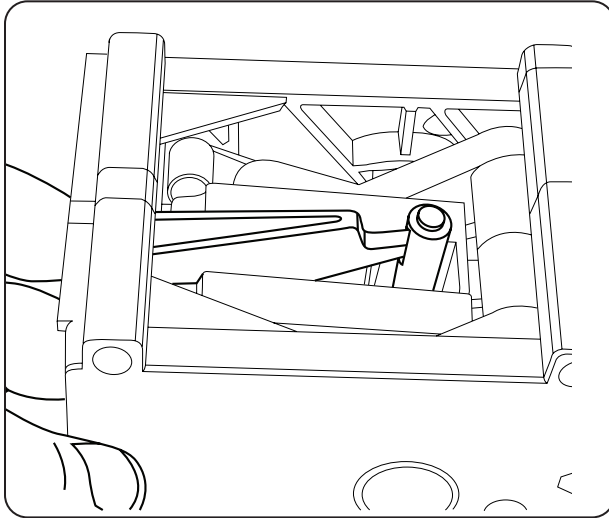

Then the fixed container should be mounted.

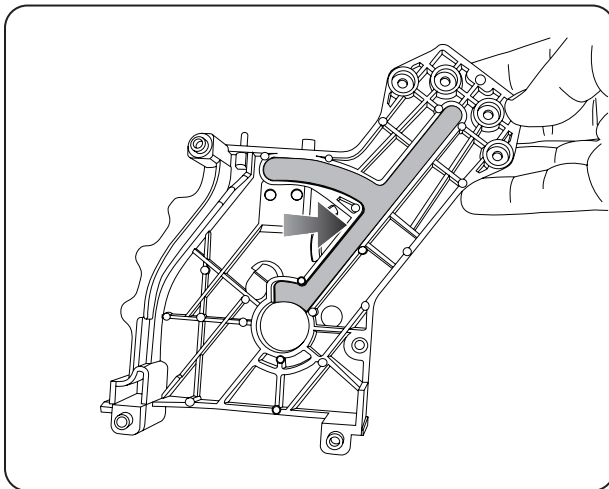

Grease, with food safe silicone grease, the rails of the two inner sides of the brew unit.

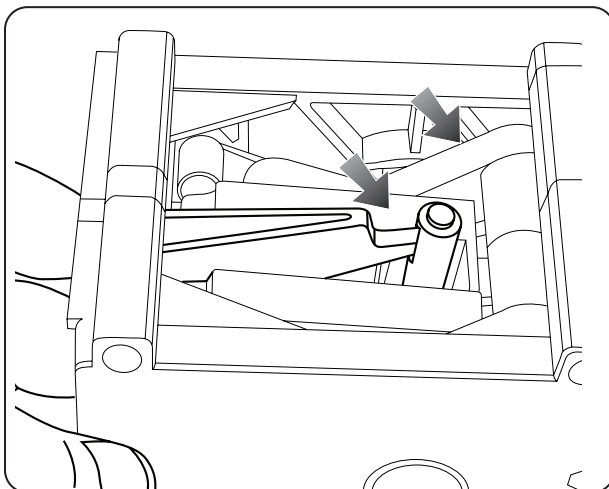

Grease, with food safe silicone grease the connecting rod and the rod.

11.18. POWER board disassembly

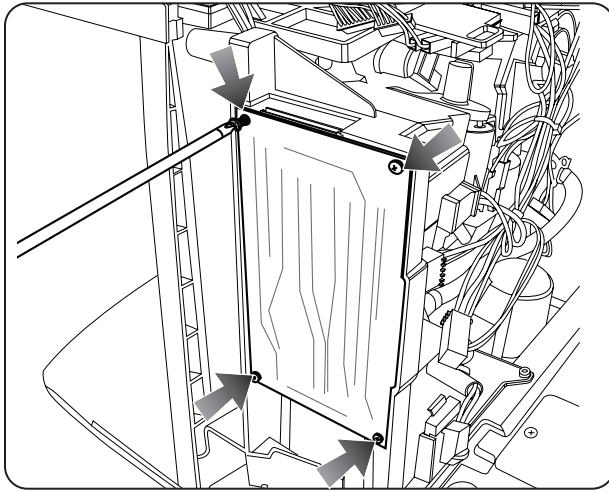

Attention

This operation must only be performed with the machine switched off..

The POWER board is situated on the side of the machine.

The transformer is situated under the POWER board.

To remove the POWER board, loosen the indicated screws.



Note

Before removing the board, make sure that all the cables of the board are disconnected.

11.19. CPU board disassembly

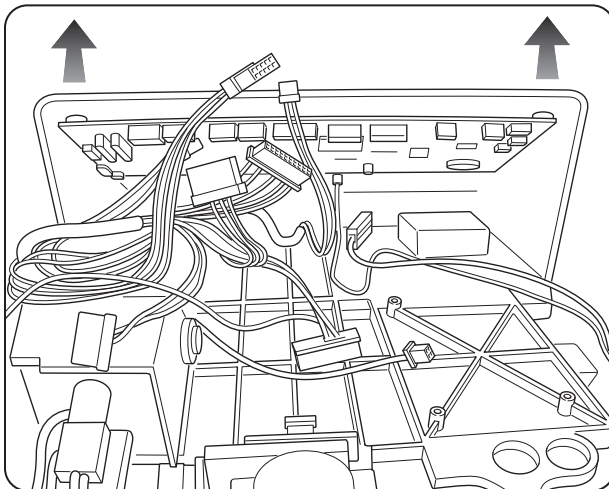

Remove as indicated in the figure all the connections that are connected to the board and lift the support up.

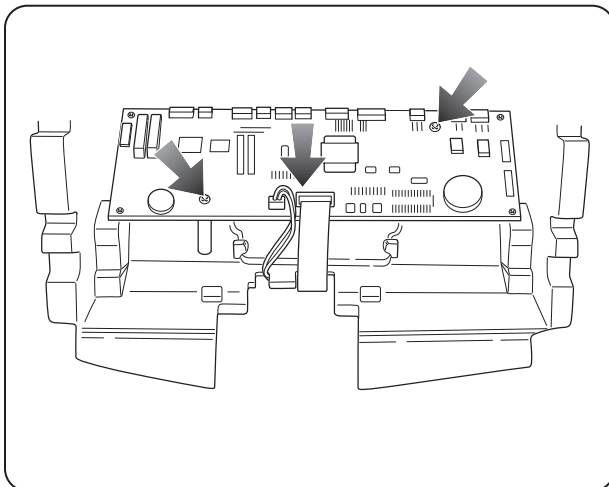

Remove the two connections and loosen the indicated screws.

11.20. Keyboard board disassembly

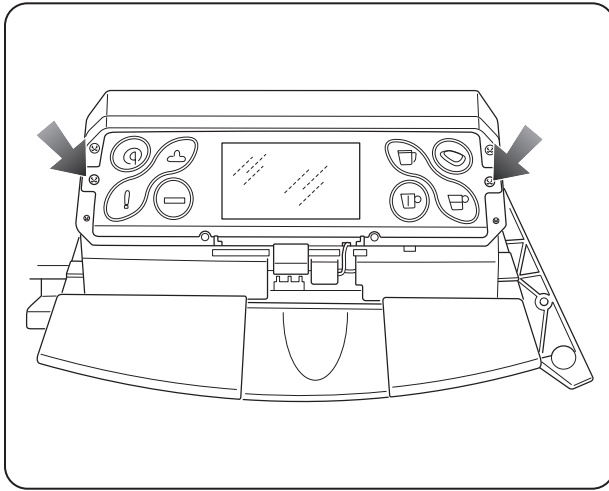

Disconnect the flat cable which connect the two capacitive boards and loosen the indicated screws to access the keyboard boards.

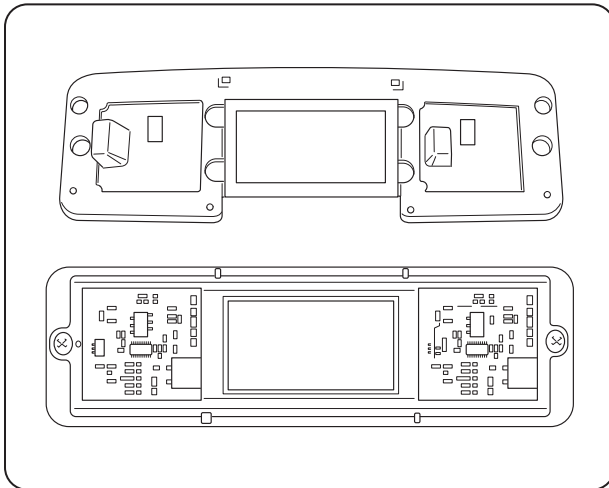

Remove the gasket by lift it up. The two boards are attached with an adhesive, lever to remove them.

11.21. Display disassembly

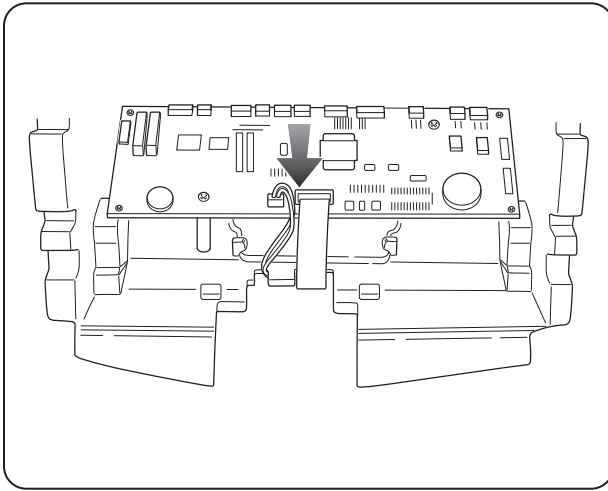

Disconnect the two indicated connections.

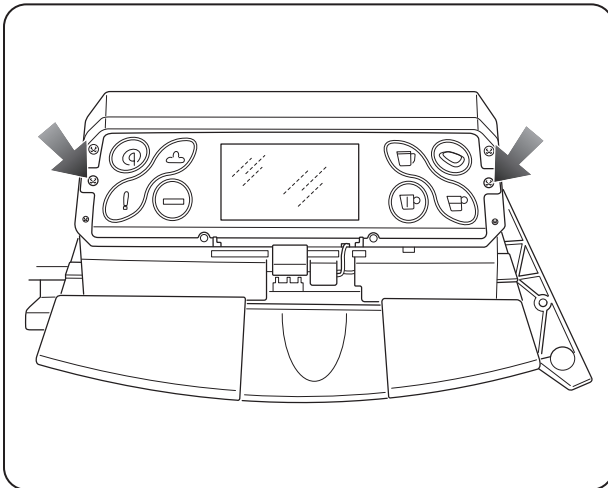

Detach the flat cable that connect the two capacitive boards and loosen the indicated screws to access the keyboard boards.

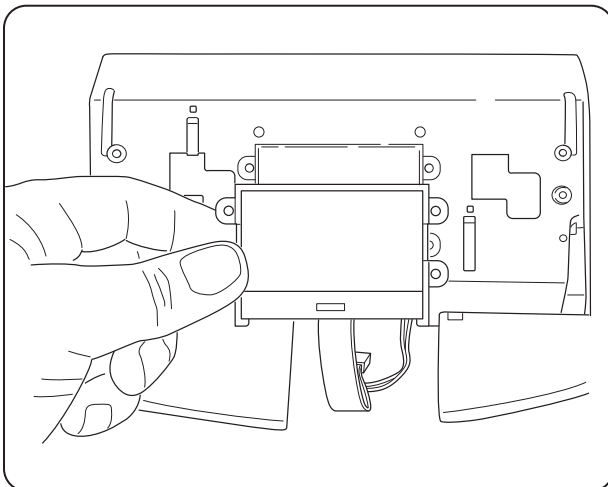

Remove the display and replace it.

11.22. Assembly and removal of the OETIKER clamps

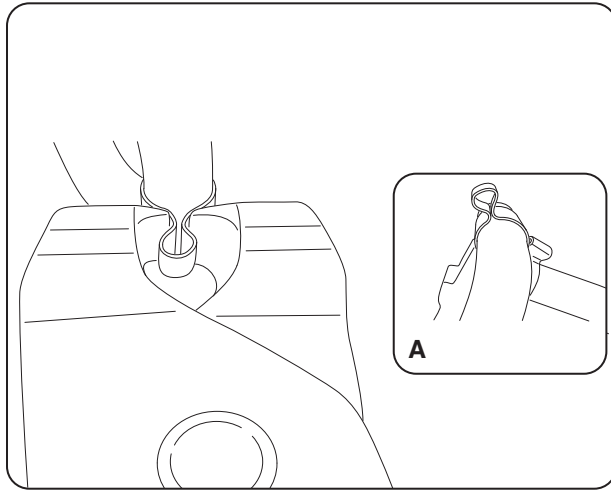

To tighten the clamp use the proper pliers.
Check the correct clamping (**A**) and positioning.

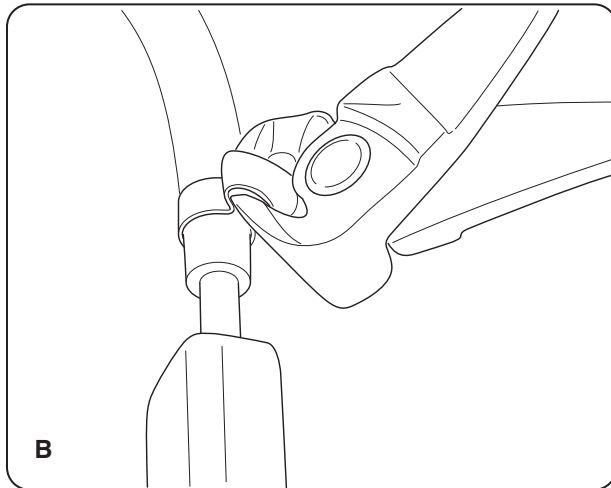

To remove the clamp use the pincers as indicated in
the figure (**B**).

