

BeoSound 4

Type 2851, 2852, 2853, 2854, 2855, 2857, 2858, 2859, 2860

Service Manual

English

German, French, Italian, Spanish, Danish, Dutch and Japanese versions are available in the Retail System

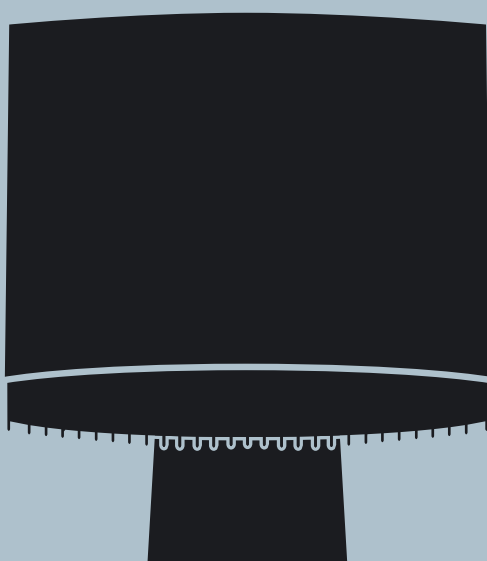

*This Service Manual must be returned
with the defective parts/back-up suitcase !*

CONTENTS

Survey of modules	1.1
How to service	1.2
PIN-code	1.3
Warnings	1.5
Final check after repair	1.6
Fault flow chart	2.1
Placement of measuring points	2.2
Placement of magnet	2.11
Service mode	3.1
Service tips	4.1
Repair tips	4.2
Replacement of modules	5.1
Specification guidelines for service use	6.1
Wiring diagram	7.1
Available parts	8.1

Survey of modules

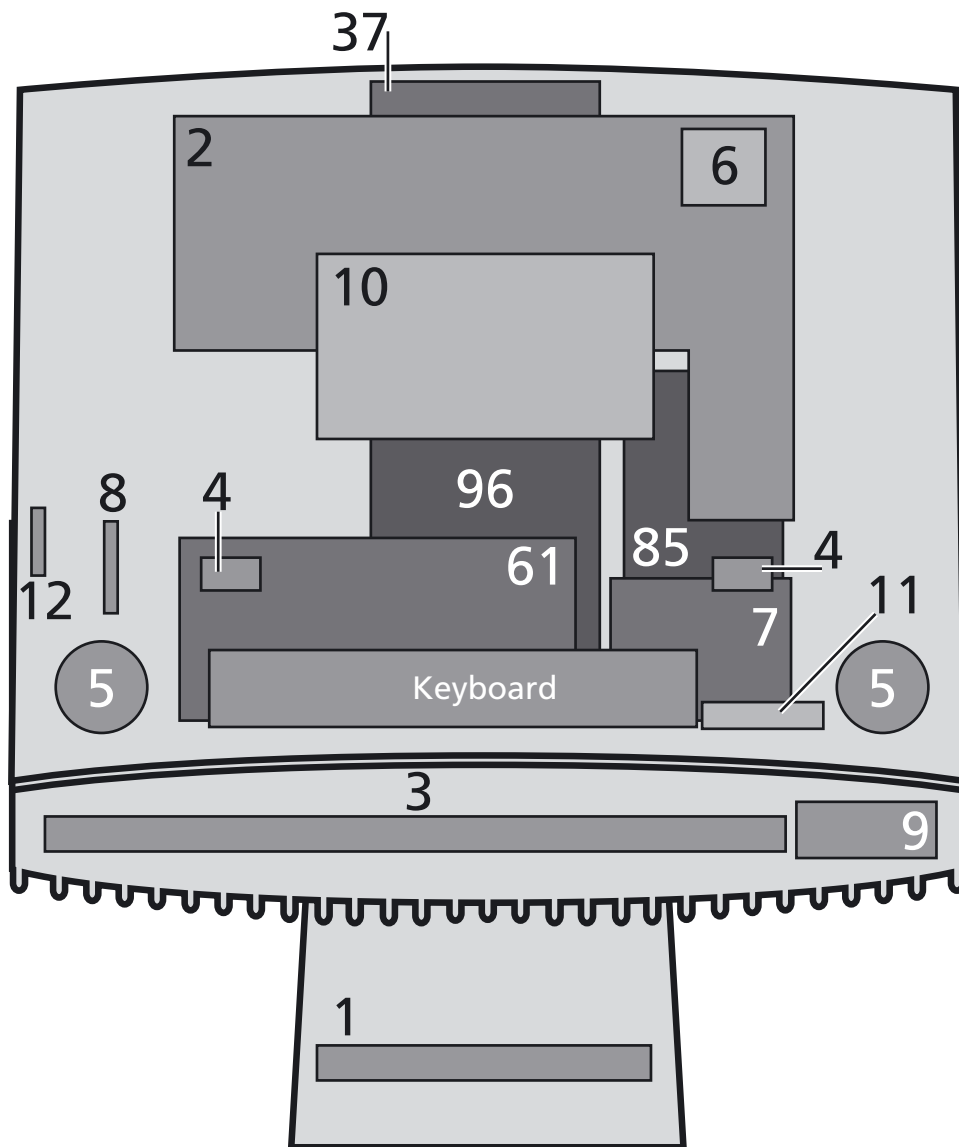

- PCB1 Socket
- PCB2 Master
- PCB3 Magic
- PCB4 Light
- PCB5 Turn wheel
- PCB6 Main microprocessor
- PCB7 Codec
- PCB8 Tacho
- PCB9 Headphone
- PCB10 Display
- PCB11 SD/MMC card reader
- PCB12 Switch
- 37Module DAB
- PCB61 SMPS
- PCB85 FM tuner EU/JP
- 96Module CD unit

How to service

Converting mains supply voltage

The unit has separate type nos. for each market, due to country approvals. The mains voltage is determined by the type nos. of the unit, there are only two internal mains voltage settings (a jumper) on the SMPS, 100/120V and 230/240V AC (P108, when mounted = 100/120V).

Front line service

The BeoSound 4 unit has been developed for simple module exchange to follow the on-site service strategy. Module exchange is possible onsite, in the shop or in the service workshop whatever is most convenient in each case. For on-site service a back-up suitcase must be used. Module exchange is the recommended way to perform service, due to the fact that most of the modules are multi-layer based, and most of the circuits are on a single main PCB. An electrical fault symptom can be removed during one visit to the customer's home, if you bring a BeoSound 4 back-up suitcase with you. Is it a mechanical symptom, the particular part must be brought with you separately.

Service documentation

Service documentation for BeoSound 4 will be a Service manual with part no. for the back-up suitcase, electrical and mechanical parts, user's guides etc.

PIN-code

The product has a 4 digit PIN-code, of the user's own choice, which must be entered if the product has been disconnected from the mains for 15-30 min.

If the PIN-code is activated, and the product has been without mains for 15-30 min., the user will be asked to enter the 4 digit PIN-code when the product is switched on.

Before the product is handed in to service it is a good idea to ask the customer to deactivate the PIN-code.

The PIN-code is activated when the product is shipped from Bang & Olufsen.

Refer to the user guide for further information.

PIN-code active prior to service

If the PIN-code is not deactivated prior to service you must use the Service code to unlock the product.

Service code

The service code

- unlocks the product, but does not affect the pin-code setting
- gives you 12 hours service time

Entering the Service code

1. When the product asks for PIN-CODE press and hold ◀◀ for 3 seconds.
2. The Master code menu appears.
3. Enter the Service code: 1 1 1 1 1.

Important notice concerning Service time

The service time is active as long as the product is connected to the mains, including Standby.

To obtain maximum service time:

Only connect the product to the mains while you are performing actual service on the product.

When the service time is expired, the product can only be unlocked by entering the PIN-code or the Master code.

Registration of the modules

The modules will be registered to the product in the following situations:

- the product has been connected to the mains for more than 12 hours, including Standby time.
- the PIN-code is activated or deactivated.

PIN-code deactivated by customer prior to service

With the PIN-code deactivated prior to service you must be aware of the modules will be registered to the product in the following situations:

- the product has been connected to the mains for more than 12 hours, including Standby time.
- the PIN-code is activated or deactivated.

The registration of modules in the product can only be changed at Bang & Olufsen.

Activate the PIN-code

Select the SETUP menu.

Press ◀ twice and then **STOP** to bring up the PINCODE SETUP menu.

Enter the 4 digit Pin-code. Re-enter the code to confirm it and press **GO**.

If you want to change or delete the PIN-code, enter the correct PIN-code and press **GO**.

It is now possible to change the PIN-code or delete the PIN-code.

Enter the PIN-code

If the PIN-code is activated and the product is disconnected from the mains for more than 15-30 minutes, a PINCODE menu appears as soon as the product is switched on.

Enter the PIN-code, and the product starts again.

If the PIN-code has been forgotten

If the PIN-code has been forgotten the only way to unlock the product again is by entering a 5 digit Master-code.

The Master-code is ordered by sending a request via the Retail System.

When the product prompts for a PIN-code, press and hold ◀ down to bring up the MASTERCODE menu.

Enter the Master-code and press **GO**. This will deactivate the PIN-code and reactivate the product.

Product locked by PIN-code

The product is locked by PIN-code when:

- The PIN-code is activated and the mains is disconnected for more than 15- 30 minutes.

The product is unlocked when the PIN-code is entered.

The PIN-code counter is set to 5 attempts within 3 hours.

When a wrong PIN-code has been entered 5 times within 3 hours, the product cannot receive any commands for a period of 3 hours.

After this period the PIN-code counter is reset.

The product must be in standby mode to activate the timer.

Warnings

ESD

When electrical replacements or disassembly all taking place, use an ESD-mat. The internal electronics are very sensitive to static electricity. When mains voltage on BeoSound 4 is required, remove the connection from BeoSound 4 to the ESD mat.

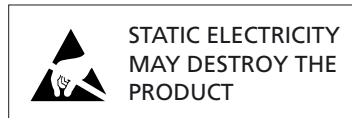

Laser exposure

BeoSound 4 contains a laser system and is classified as a class 1 laser product. BeoSound 4 must be opened by qualified personal only.



General warnings

Wear cotton gloves to avoid fingerprints on the product. The display surface on the product is very sensitive, so handling should be done with great care to avoid damage. When transporting BeoSound 4, it is recommended to use the product cover, part no. 3375490. Be sure that the plugs in each end are connected correctly.

Cleaning

Clean BeoSound 4 surfaces using DuPont Polishing Cloth, part no. 3624018. Finally clean the front glass with DuPont Final Tack Cloth. It prevents electrostatic buildup. Never use alcohol or other solvents to clean any parts of BeoSound 4.

Final check after repair

Isolation test

Each set must be insulation tested after having been dismantled. Make the test when the set has been reassembled and is ready to be returned to the customer. Flashovers must not occur during the testing procedure! Make the insulation test as follows: Short-circuit the two pins of the mains plug and connect them to one of the terminals of the insulation tester. Connect the other terminal of the insulation tester to the chassis pin of the aerial socket.

NOTE!

To avoid damaging the set, it is essential that both terminals of the insulation tester have good contact. Slowly turn the voltage control of the insulation tester until a voltage of 2.5 kV and max. 5 mA is obtained. Maintain that voltage for one second, and then slowly turn it down again.

Isolation test at the customer

Remove the mains cable from the wall outlet. Place a jumper across the two AC plug prongs. Use a multi-meter, set for measurements in the ohm-area. Place one lead from the multi-meter on the AC plug and place the other lead on ground at the power link plug. The resistance during this measurement must be of 1 mega ohm or more. Resistance measured below 1 mega ohm indicates an abnormal situation and corrective action must be taken.

Test of the device

After the insulation test, it is important to do the final test of the device, to make sure there are no other faults.

1. Turn on BeoSound 4 and load a CD. Play the CD.
2. Switch to SD play mode.
3. Switch to FM radio and make a tuning.
4. Switch to DAB radio and make a tuning.
5. Use volume up/down.
6. Make sure that both the remote control and the buttons work perfectly.

Before finishing the device, make sure that the option setting is correct.

Fault flow chart

Instructions

Instructions before trouble shooting in the fault flow chart:

- In the following fault flow chart BeoSound 4 is named BS4.
- Never connect or disconnect a socket, when the power is turned on. Disconnect the mains supply and wait minimum 30 seconds for the electrolytic capacitors to discharge.
- When measuring voltages BS4 must be in CD mode,

When fault finding in CD use Bang & Olufsens test CD 3634031 (SBC444A).

Placement of measuring points

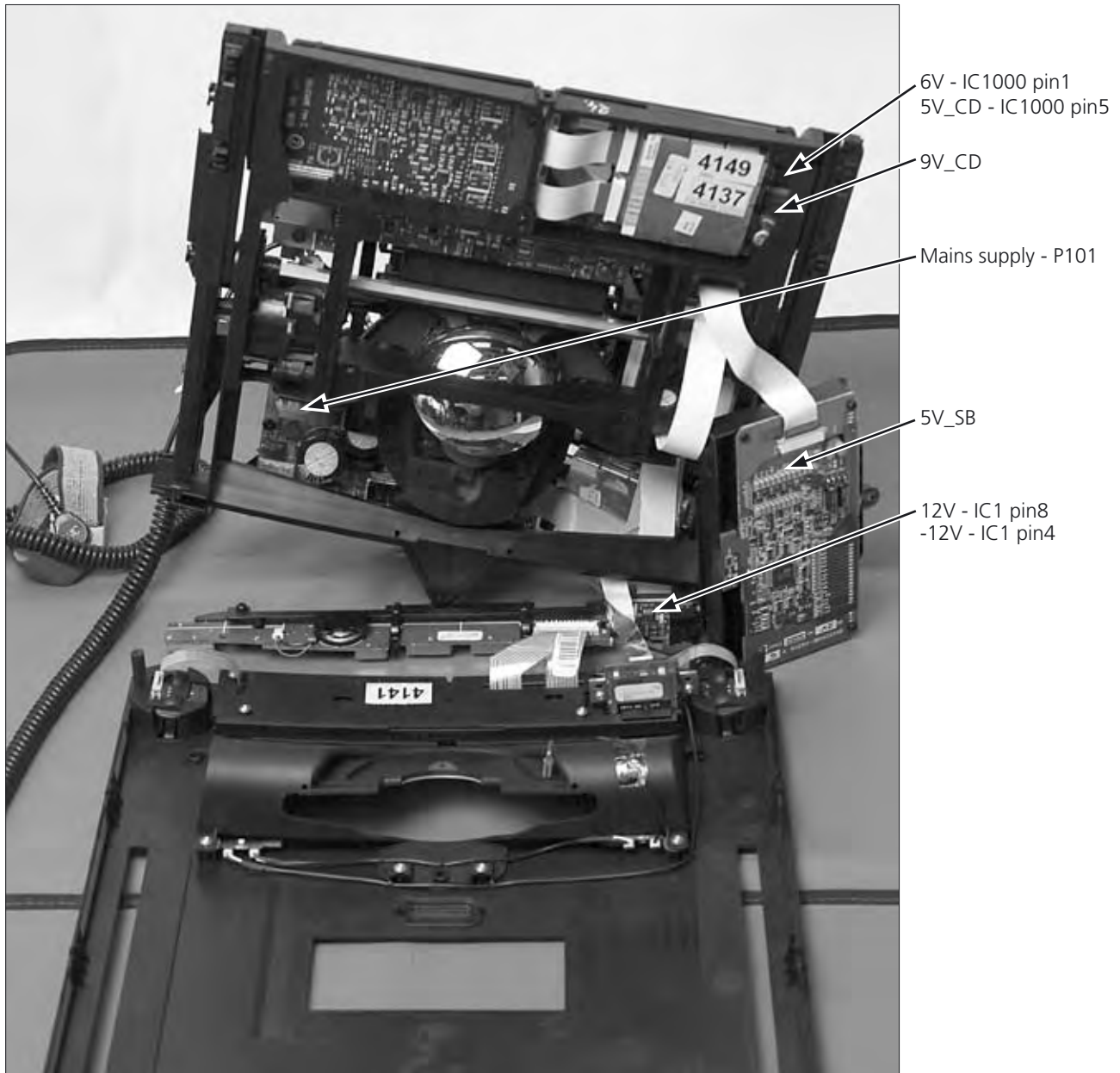

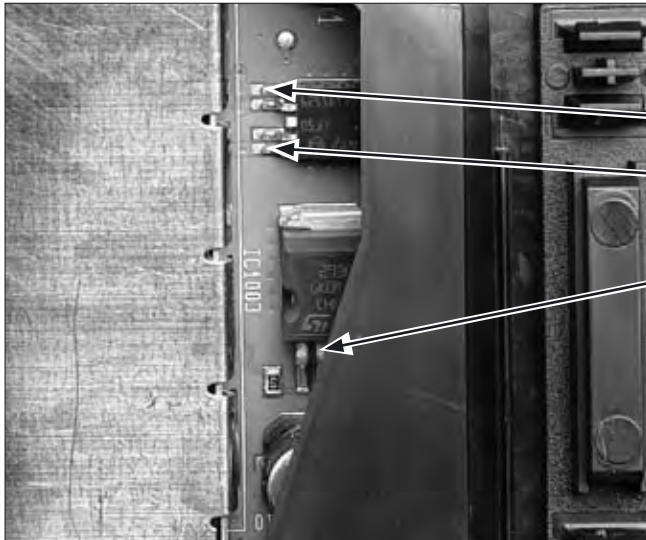

@uPH8

6V

5V_CD

9V_CD

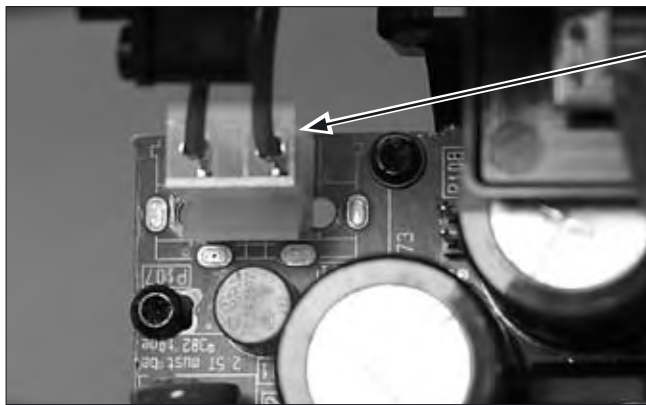

Mains supply
P101

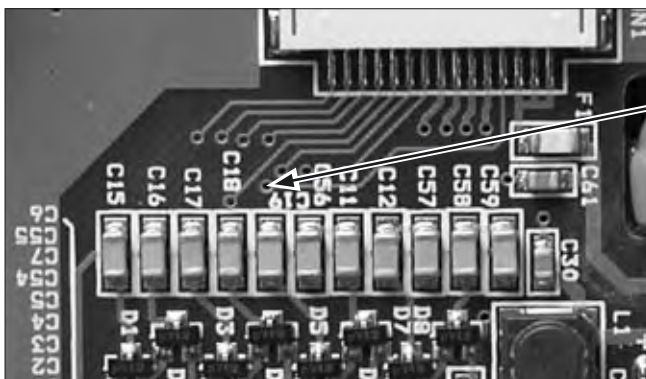

@back of display

5V_SB

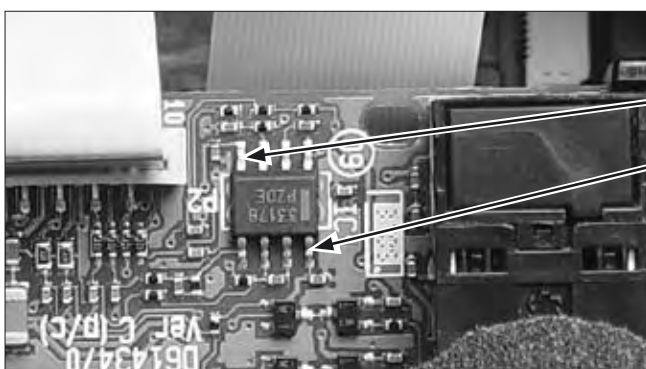

@Headphone jack

-12V

+12V

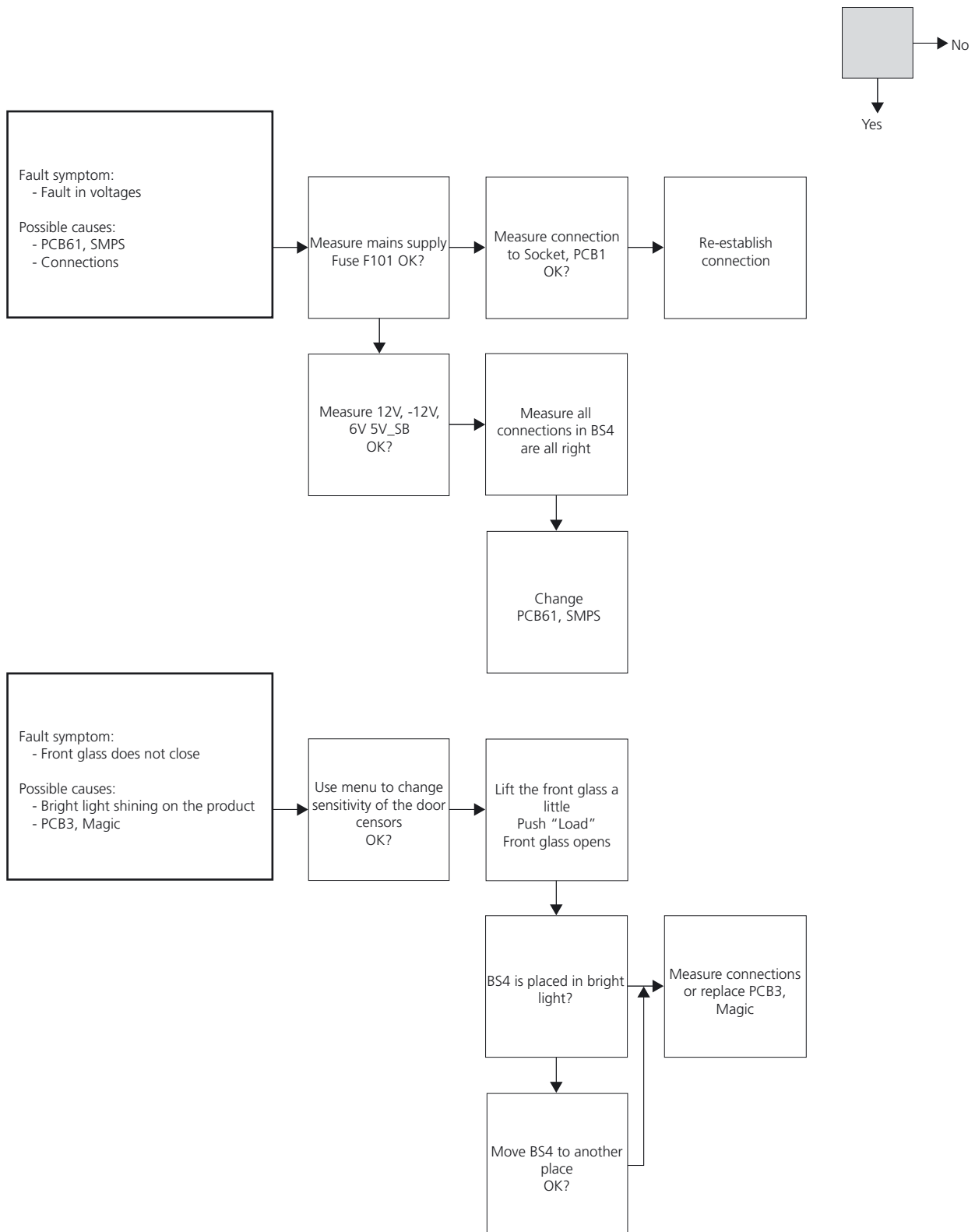

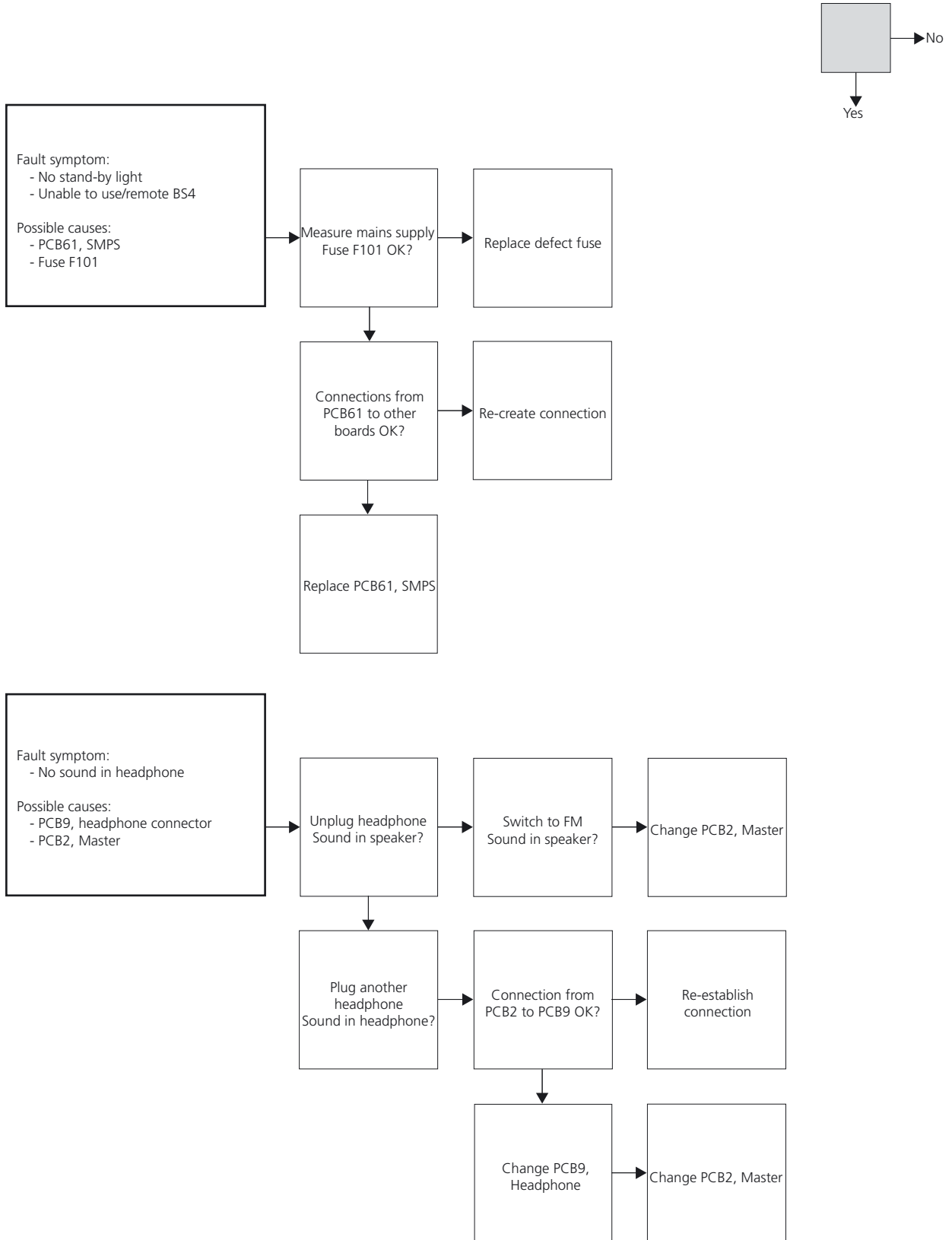

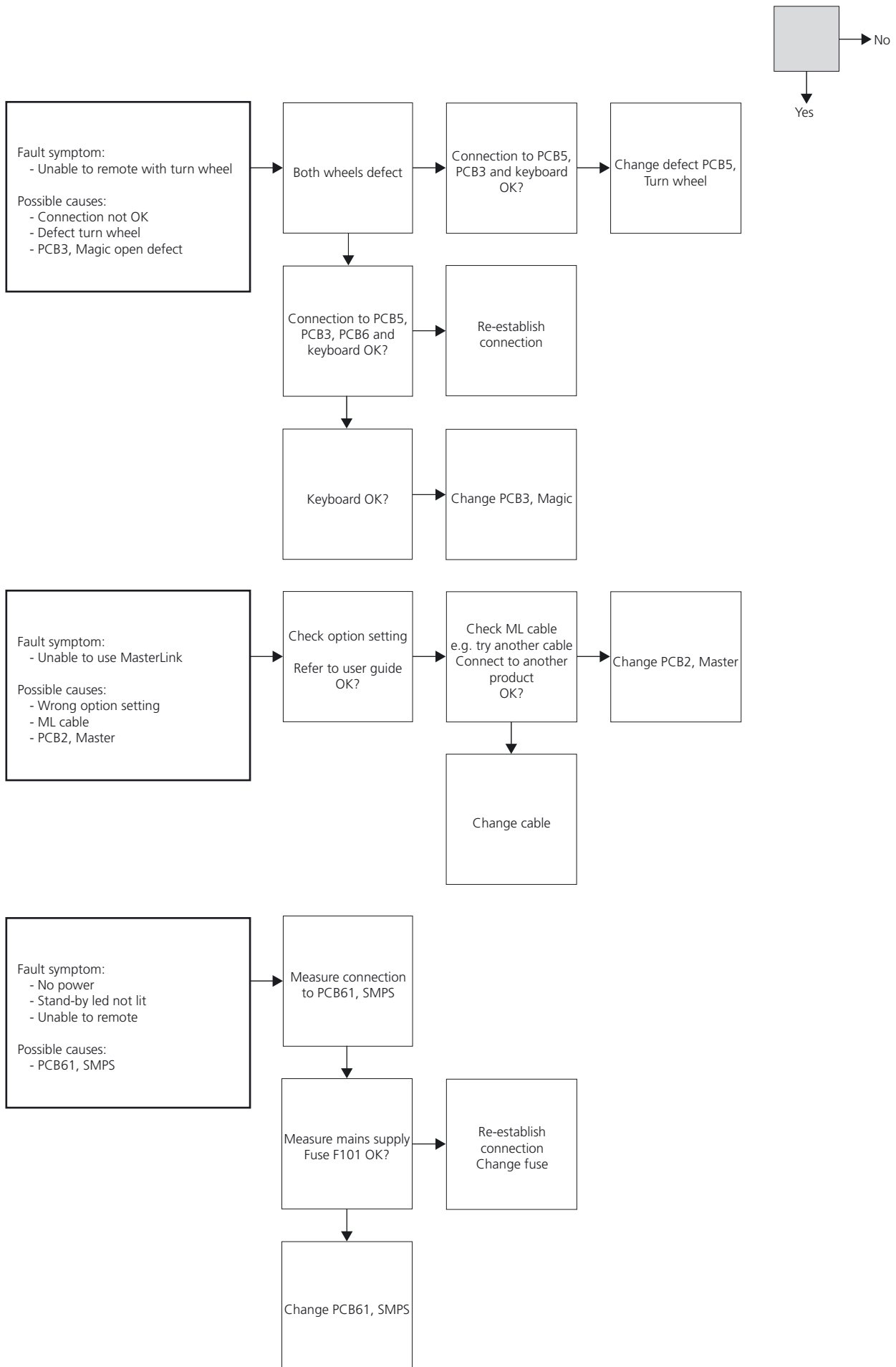

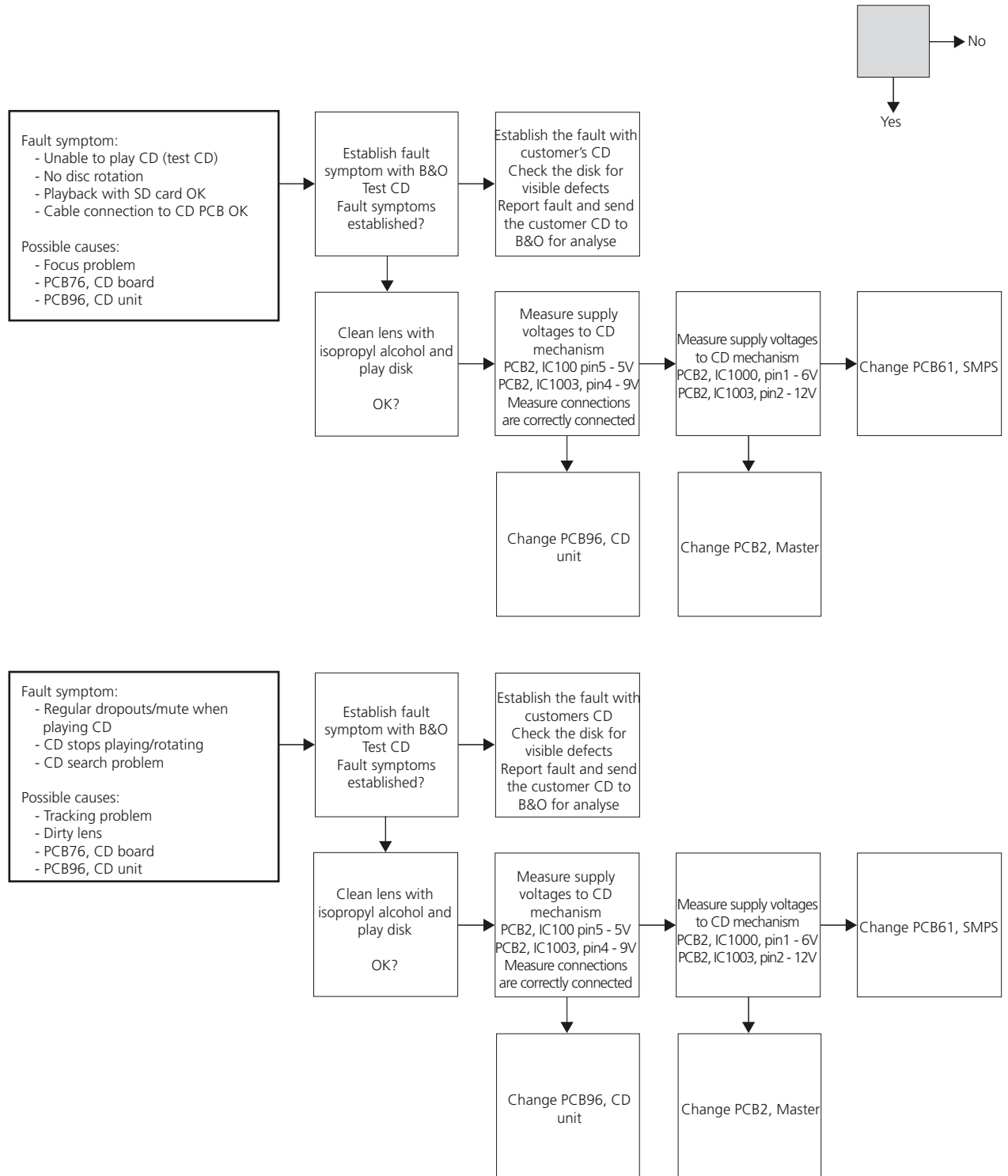

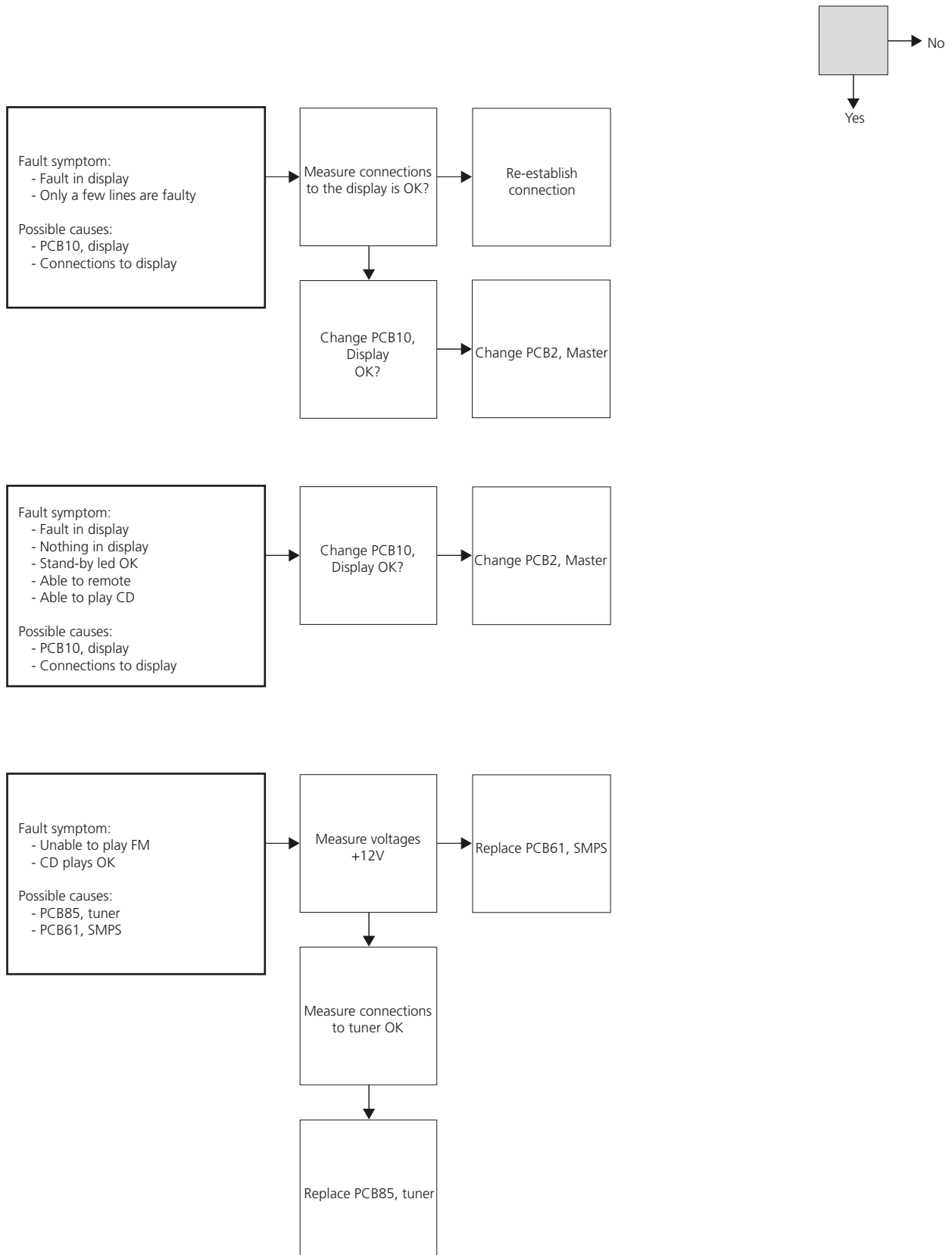

Fault symptom:
 - Unable to play DAB
 - CD plays OK
 - FM plays OK

Possible causes:
 - PCB37, DAB
 - PCB61, SMPS

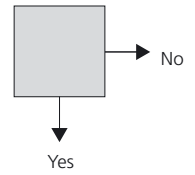
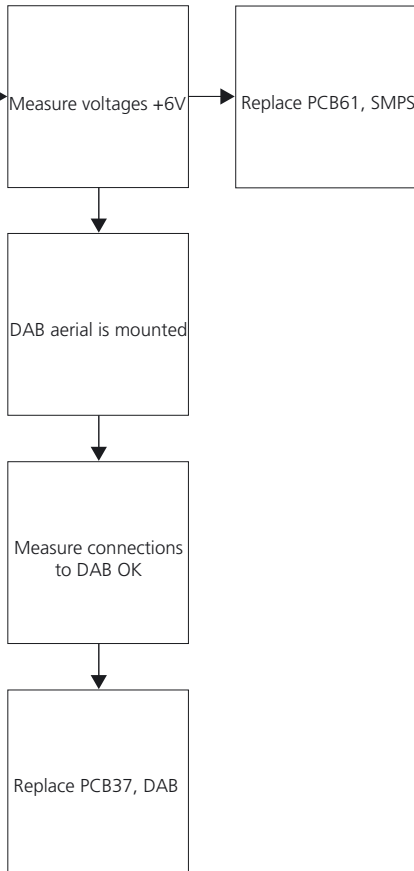

Fault symptom:
 - Unable to open front glass

Possible causes:
 - PCB3, Magic door censor
 - PCB61, SMPS
 - Motor

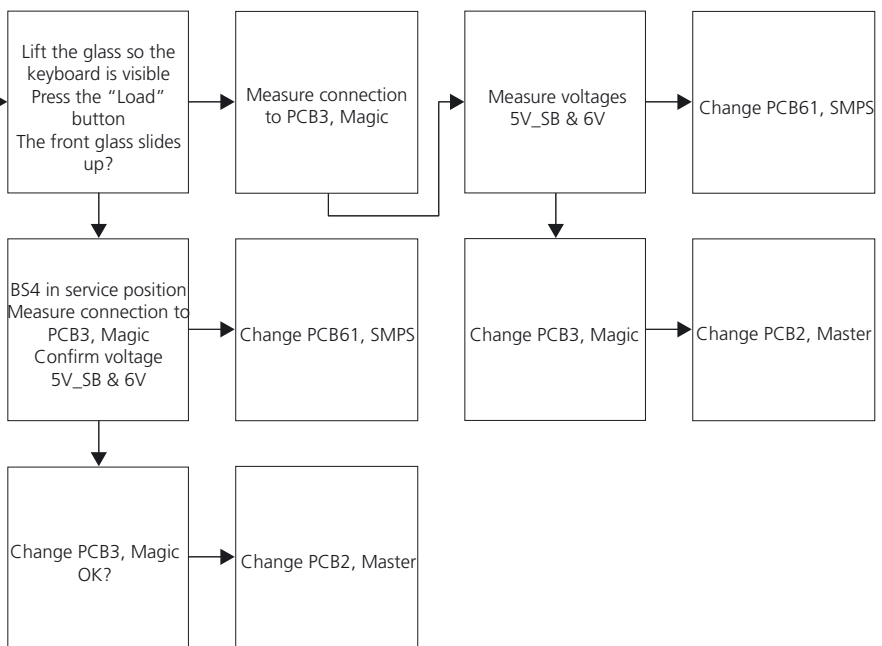

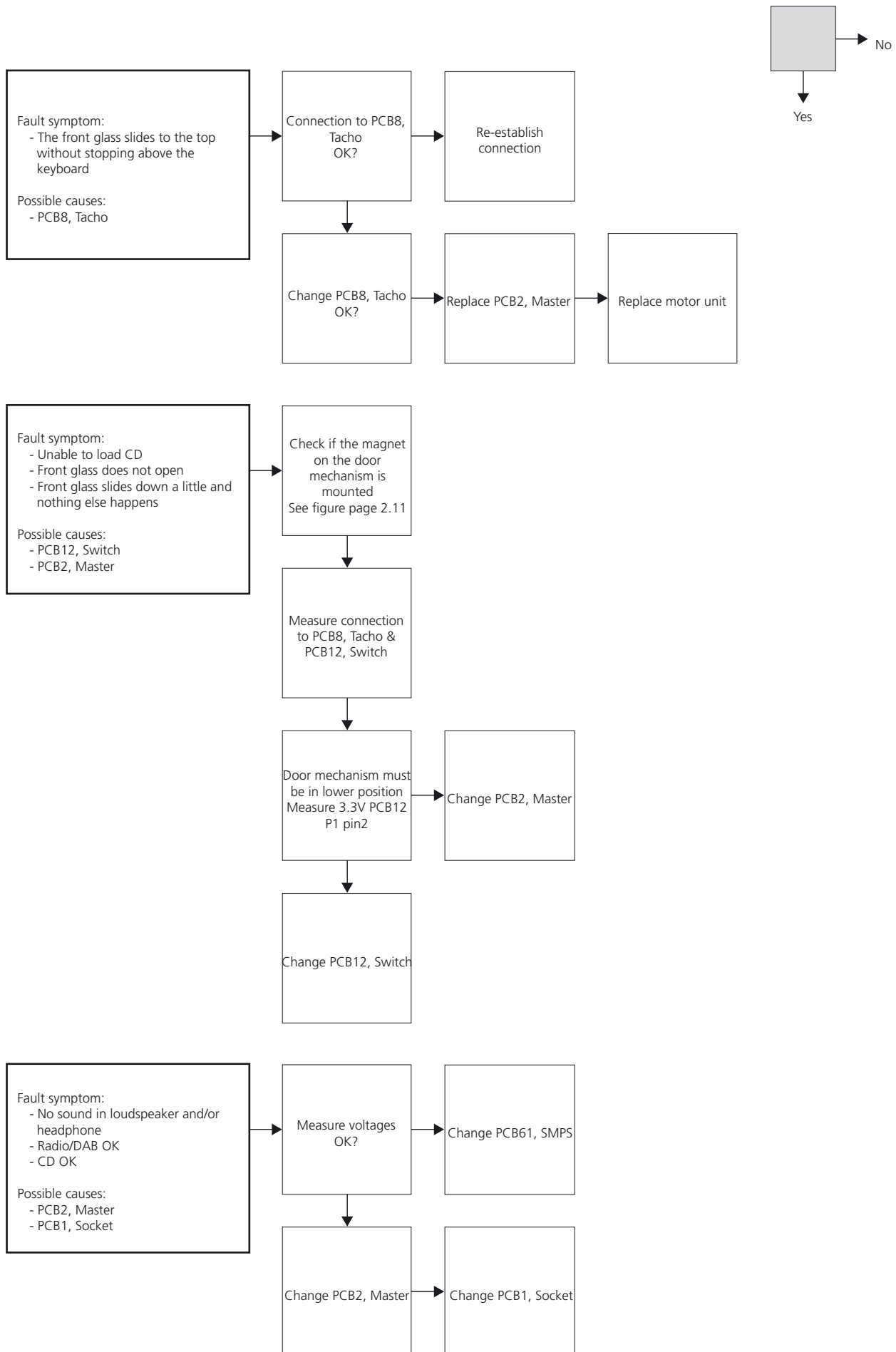

Placement of magnet

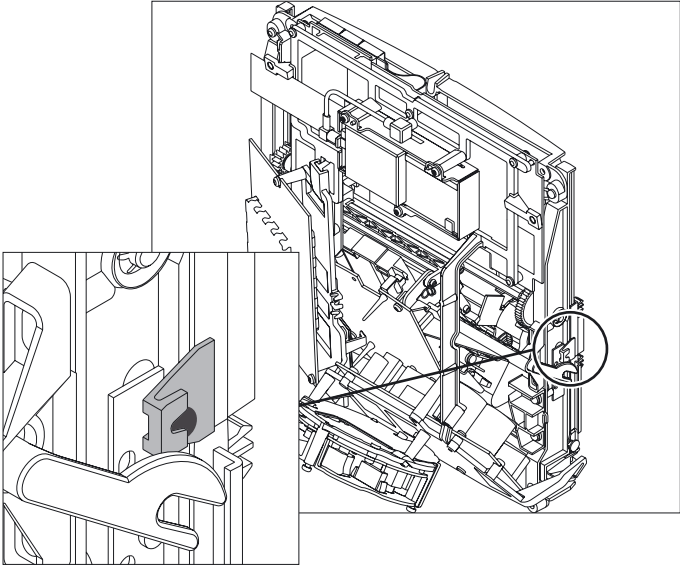

Not completed

Not completed

Service tips

Service tool

Along with a Cable kit for ServiceTool (3375397) and a P.I.T. box (3375055) it is possible to flash-update the FEP software. From the service module a special service cable goes to the BeoSound 4 unit. From the service module another service cable goes to a laptop.

On the service module, you are able to select which software you want to flash-update via a switch. You will need to get the ServiceTool program installed on your laptop, this can be downloaded from the Retail System. A fully described instruction is enclosed when the P.I.T. box is ordered (3375055).

Repair tips

CD

The diodes and the laser are very sensitive to static electricity. Damaging the diodes or laser may reduce their lives dramatically. So be sure, that the workstation is protected against static electricity.

The product may not be connected to the mains, when the CD mechanism or 96Module is removed.

Normally, the CD will find focus first, and when that has been found, it will start the turntable motor. This means that if the motor cannot start, the reason may be that focus has not been found.

Exchange of the microprocessor and PCB2

When replacing the PCB6 remember to move the EEPROM 6IC6 from the defective PCB6 to the new PCB6, because it contains valuable data (serial no. and PIN code etc). The data is not transferred to the new module until you have been in contact with the PIN-code protection or after 12 hours of connection to the mains. This means that you can try out a new PCB6 without transferring the product's serial no. etc.

Note!

When the serial number has been transferred to the microprocessor, it can only be used for this specific product; it must go back to Bang & Olufsen's module repair department as an exchange module to be erased again. If the product functions are OK, and the PIN-code protection is also OK; there is no need to test the functionality of the PIN-code protection.

Exchange of software EEPROM on PCB6

When exchanging the EEPROM on PCB6, the data from the microprocessor will be written into the EEPROM, when selecting any source e.g. RADIO.

It is possible to borrow an EEPROM from another BeoSound 4 to test, if there is suspicion of a fault in the original EEPROM. The EEPROM will always adopt the data from the main microprocessor.

Replacing of both PCB6 and EEPROM 6IC6

If both PCB6 and the EEPROM 6IC6 need to be replaced it is necessary to have them pre-programmed from Bang & Olufsen with the correct serial no., otherwise they will not work. Please contact Bang & Olufsen.

Replacement of modules

Replacement of the PCB61 (SMPS)

When replacing PCB61 (SMPS), remember to check jumper at 61P108

Mains voltage 115V = jumper at 61P108 must be mounted

Mains voltage 220V = jumper at 61P108 must be removed

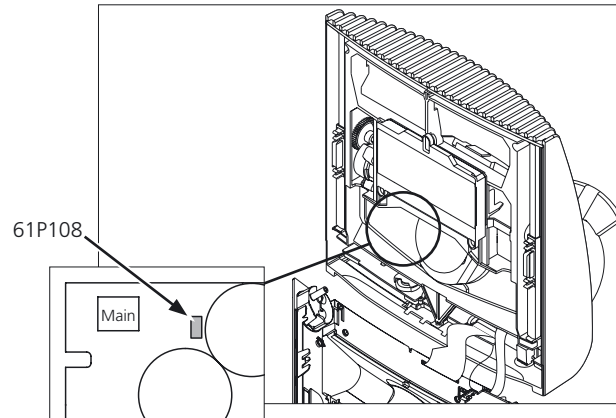

Replacement of the Main microcomputer PCB6 (μ PH8)

When replacing the PCB6 remember to move the EEPROM 6IC6 from the defective PCB6 to the new PCB6, because it contains valuable data (Serial no., PIN-code etc.). The data is not transferred to the new module until you have been in contact with the PIN code protection or after 12 hours of connection to the mains. This means that you can try out a new PCB6 without transferring the products serial no. etc.

Note!

When the serial number has been transferred to the micro-processor, it can only be used for this specific product; it must go back to Bang & Olufsen's module repair department as an exchange module to be erased again. If the product functions are OK, and the PIN-code protection is also OK; there is no need to test the functionality of the PIN-code protection.

Exchange of software EEPROM on PCB6

When exchanging the EEPROM on PCB6, the data from the micro-processor will be written into the EEPROM, when selecting any source e.g. RADIO.

It is possible to borrow an EEPROM from another BeoSound 4 to test, if there is suspicion of a fault in the original EEPROM. The EEPROM will always adopt the data from the main micro-processor.

Replacing of both PCB6 and EEPROM 6IC6

If both PCB6 and the EEPROM 6IC6 need to be replaced it is necessary to have them pre-programmed from Bang & Olufsen with the correct serial no., otherwise they will not work. Please contact Bang & Olufsen.

Disassembly overview

PCB	Module name	Page
1	Socket	5.5
2	Master	5.6
3	Magic	5.8
4	Light	5.9
5	Turn wheel	5.10
6	Main microprocessor	5.7
7	Codec	5.11
8	Tacho	5.12
9	Headphone	5.13
10	Display	5.14
11	SD/MMC card reader	5.15
12	Switch	5.16
37Module	DAB	5.20
61	SMPS	5.17
85	FM tuner	5.18
96Module	CD unit	5.19
	Cabinet	5.21
	Clamper cover	5.22
	Clamper unit	5.23
	Base	5.24
	Door mechanism	5.25
	Drivebelt	5.26
	Finger niche	5.27
	Keyboard	5.28
	Motor	5.29

- Remove all cables

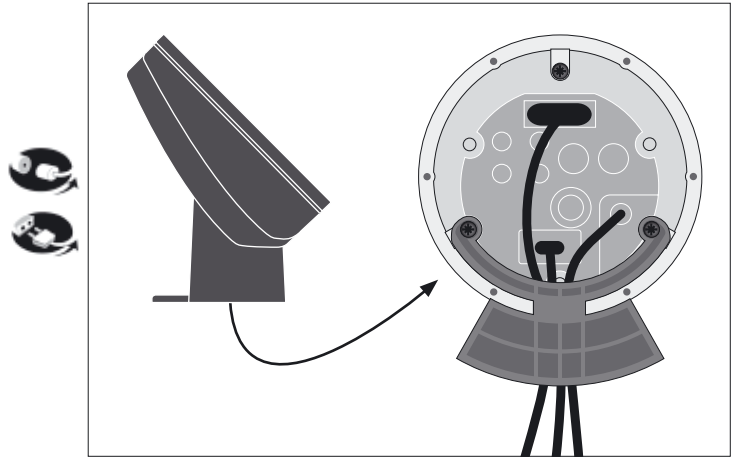

- Push front glass to top position and remove it

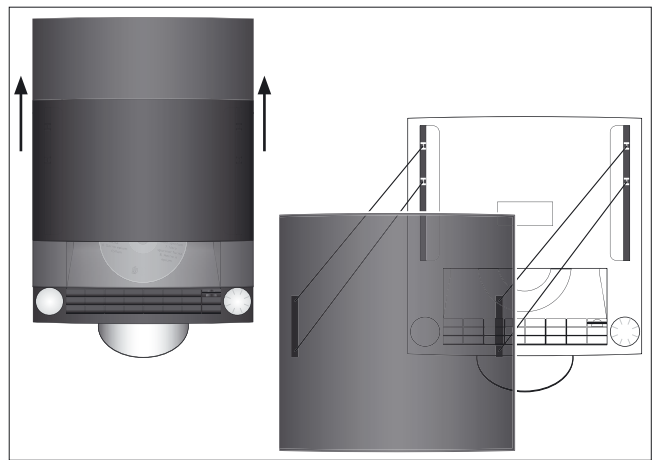

- Remove screw covers at top - and all screws

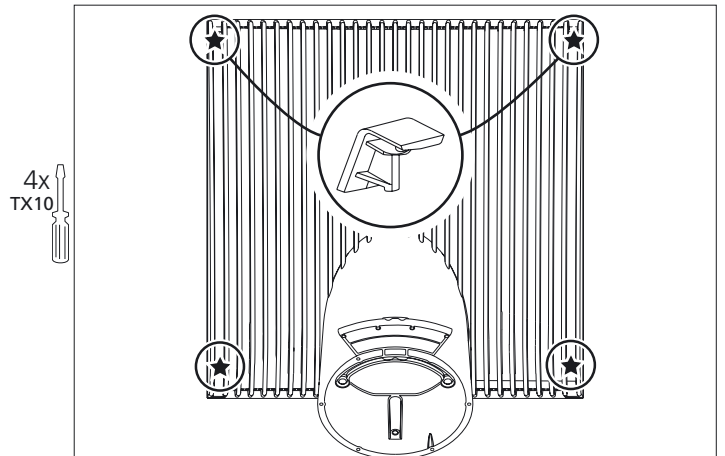

- Remove cables

Plug with lock!
8P1 and 5P2

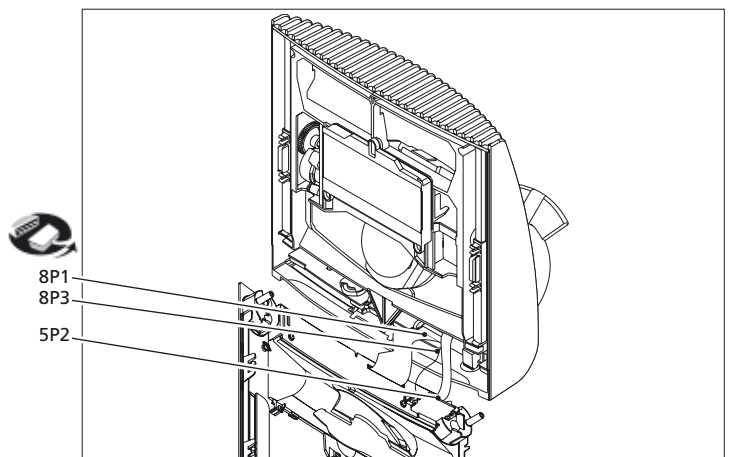
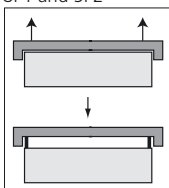

5.3 BeoSound 4 in Service Position

- Remove screws at socket panel

3x
TX10

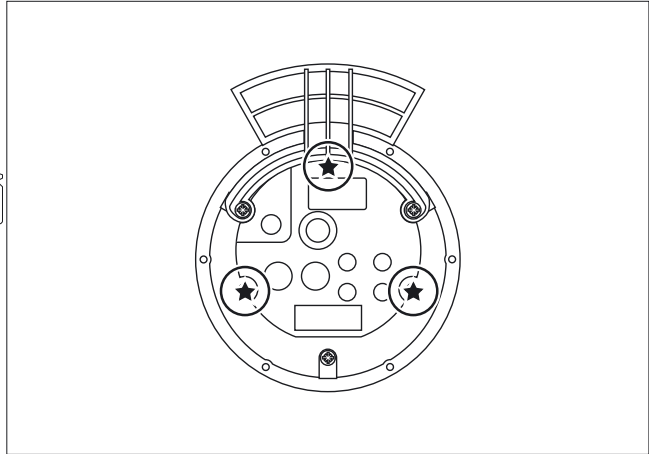

- Remove screws at front

4x
TX10

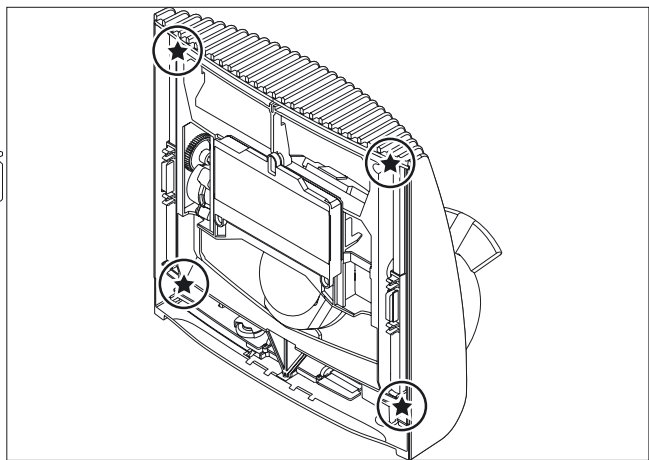

- Remove cables

2P1002
2P1009

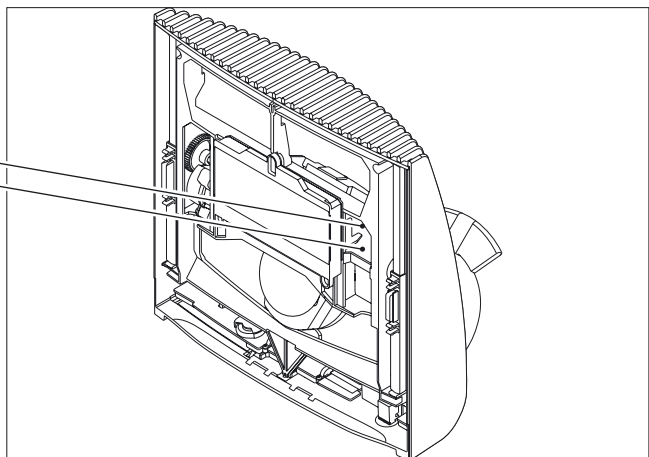

- Pull out chassis

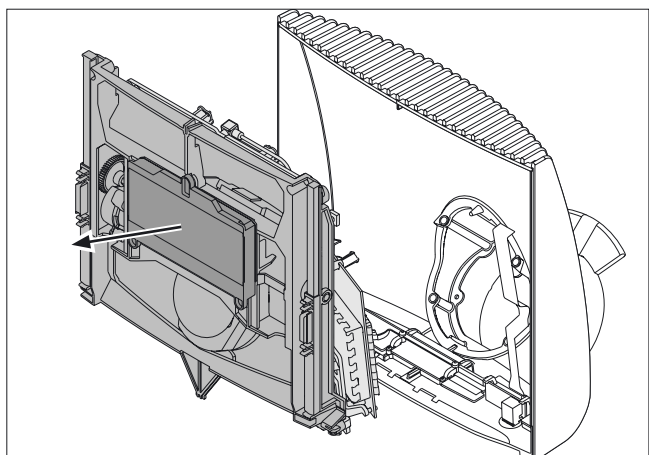

5.3 BeoSound 4 in Service Position

5.4 Remove Chassis

- Remove plugs

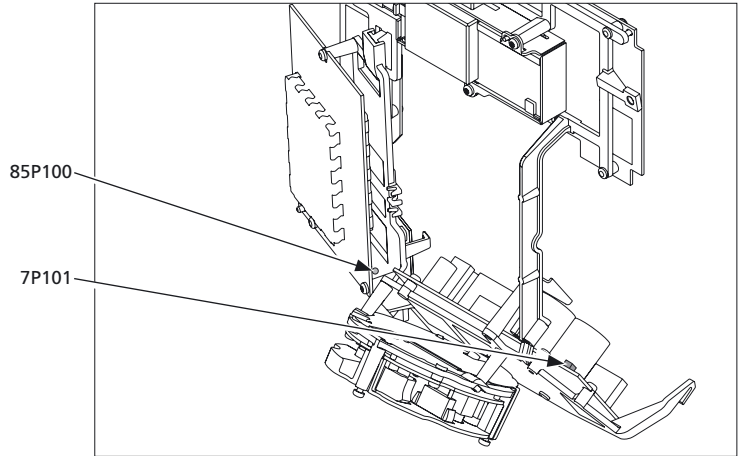

- Pull off socket cover

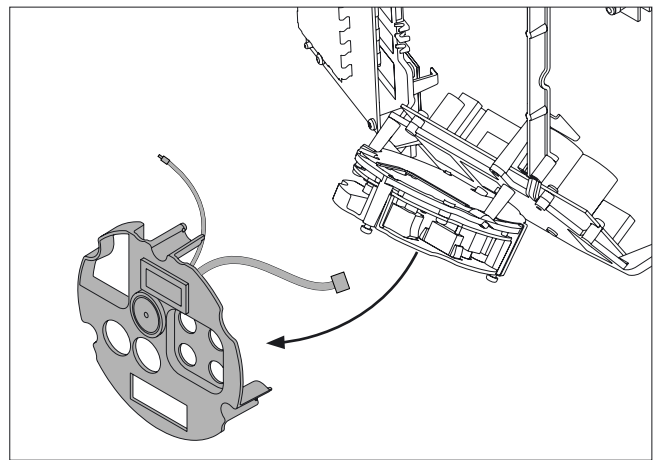
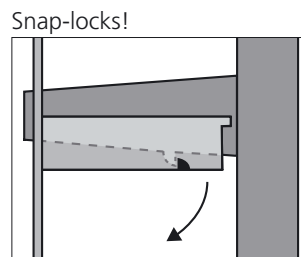

- Remove plugs

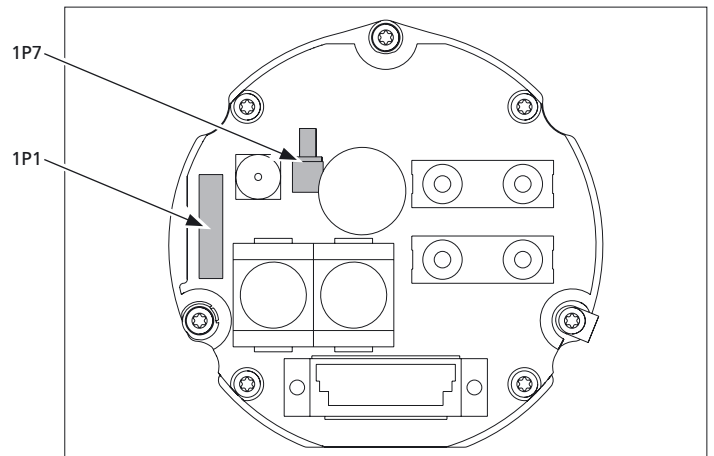

- Remove screws

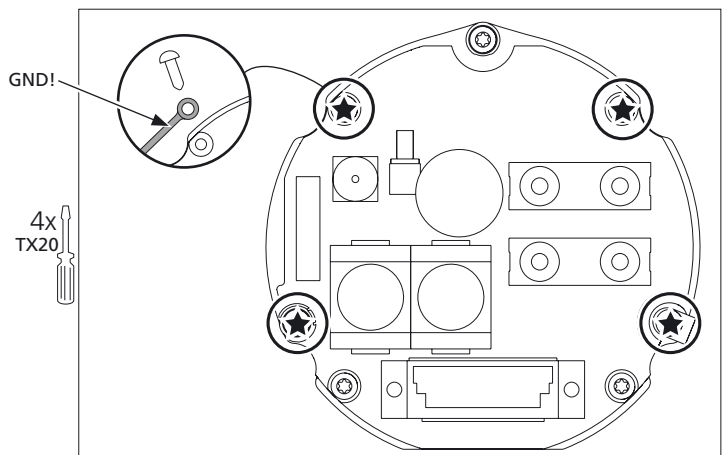

5.3 BeoSound 4 in Service Position

5.4 Remove Chassis

- Remove screws and release snaplocks

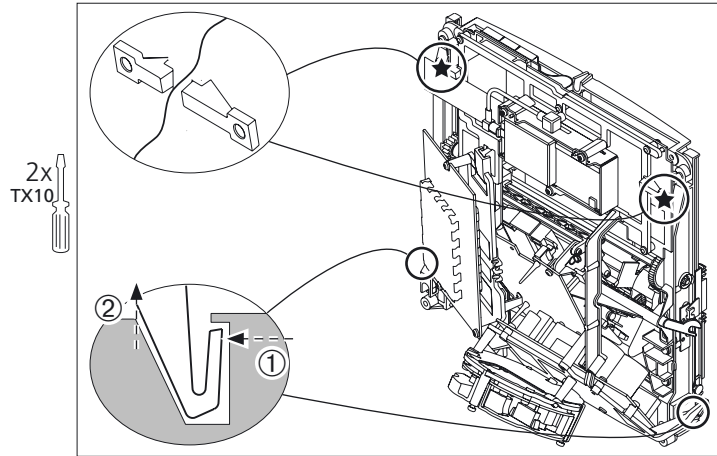

- Remove plugs

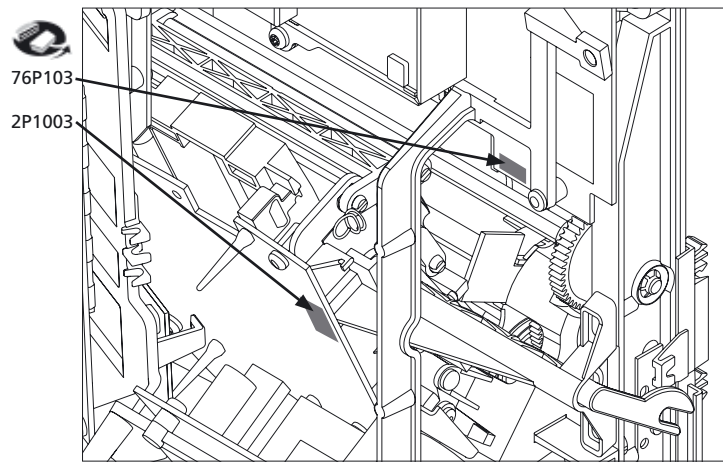

- Remove electrical chassis from mechanical chassis

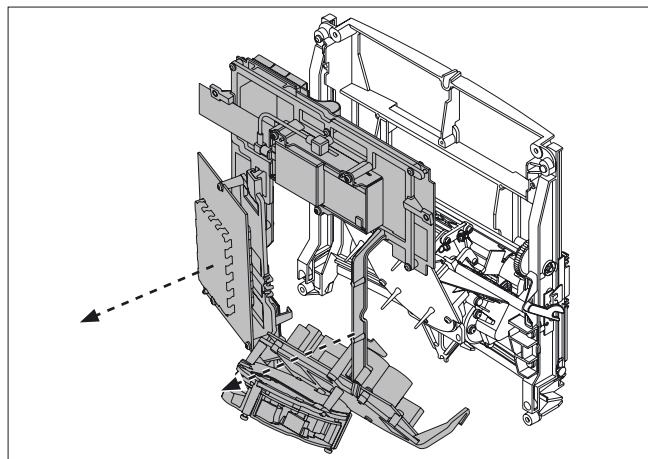

- Remove cables PCB2

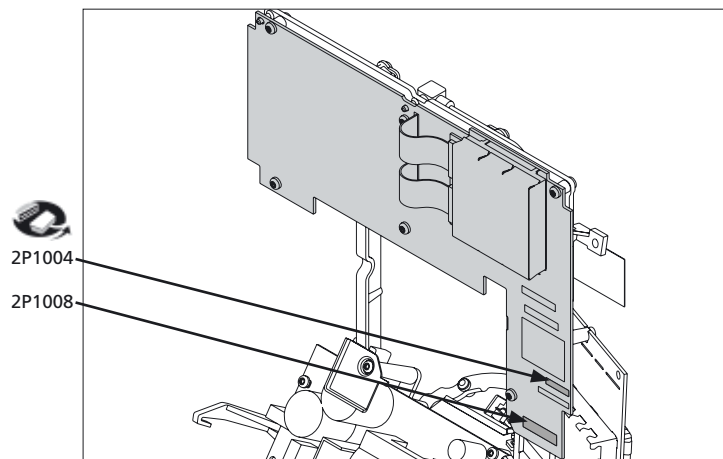

→ - Remove screws

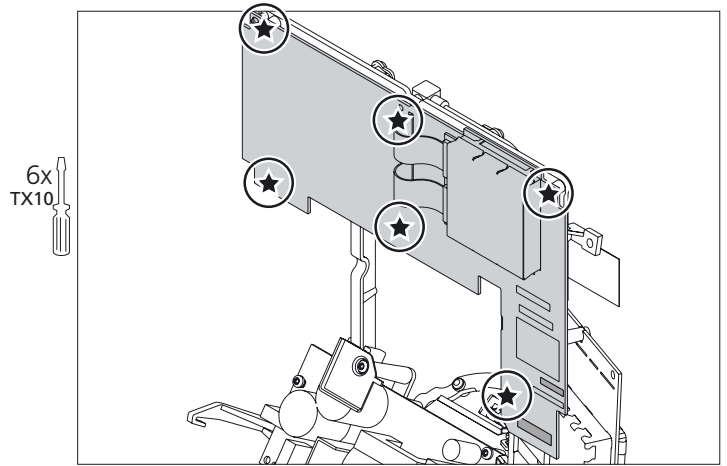

- Remove plugs on the back of PCB2

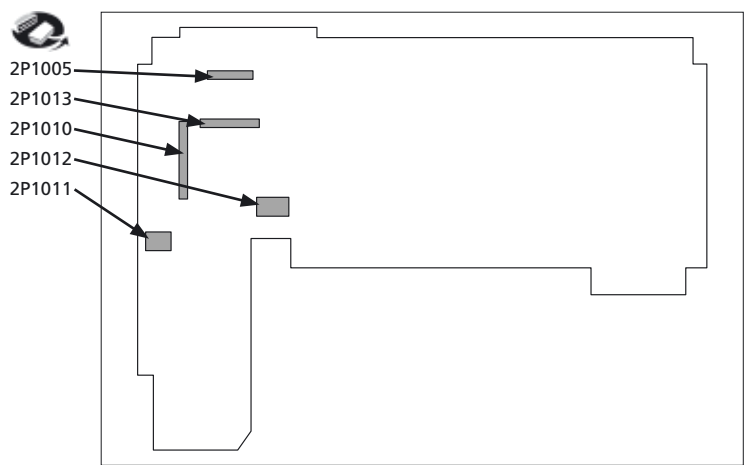

- Transfer EEPROM software

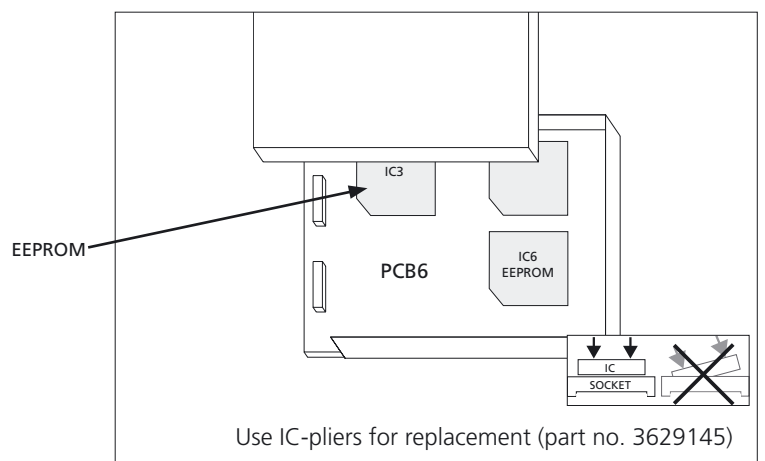

5.3 BeoSound 4 in Service Position

5.4 Remove Chassis

- Remove screws

2x
TX7

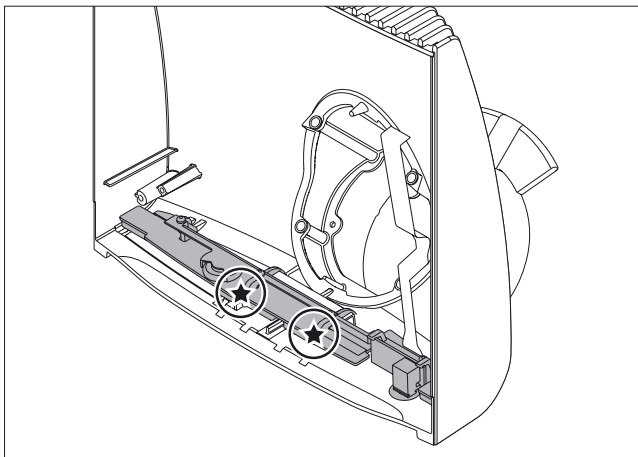

- Remove PCB3, Magic

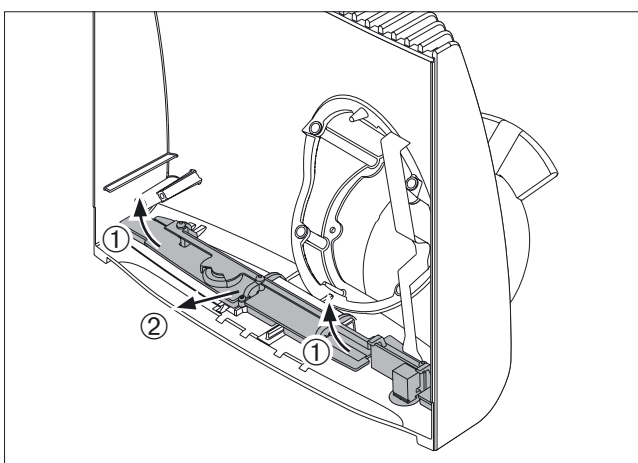

- Remove PCB9, Headphone

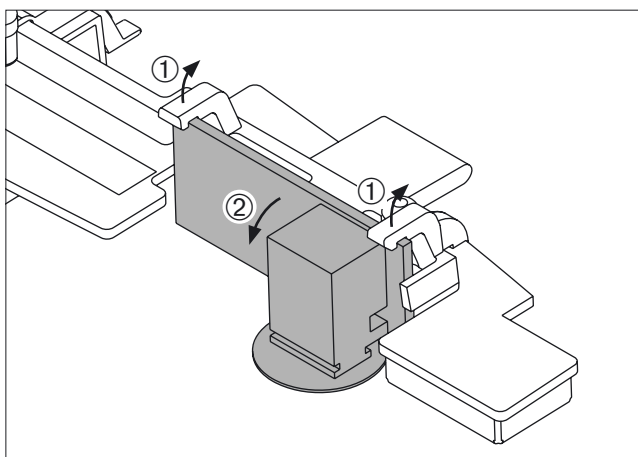

- ▣ 5.3 BeoSound 4 in Service Position
- ▣ 5.27 Remove finger niche
- Remove PCB4, Light

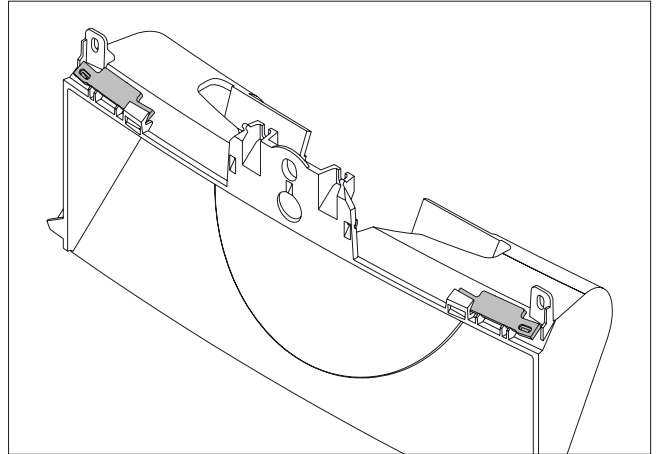

5.3 BeoSound 4 in Service Position

- Remove cable

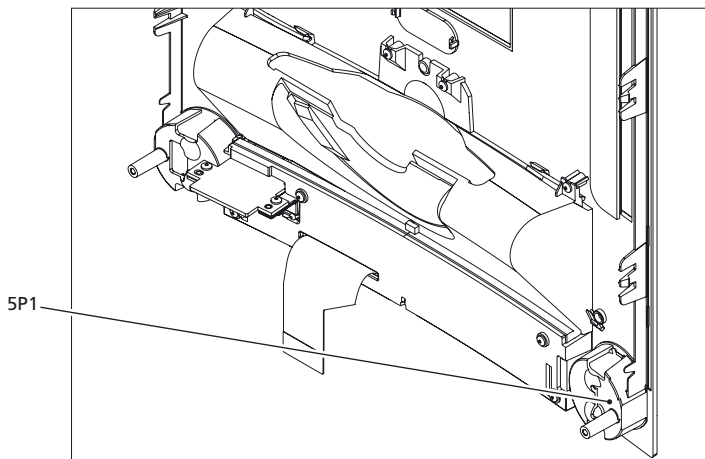

- Release snaplocks and push out

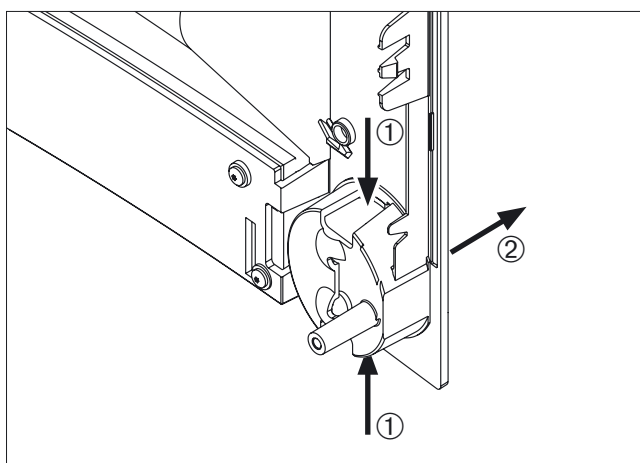
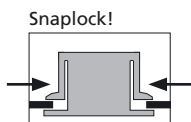

- Dismantle turn wheel

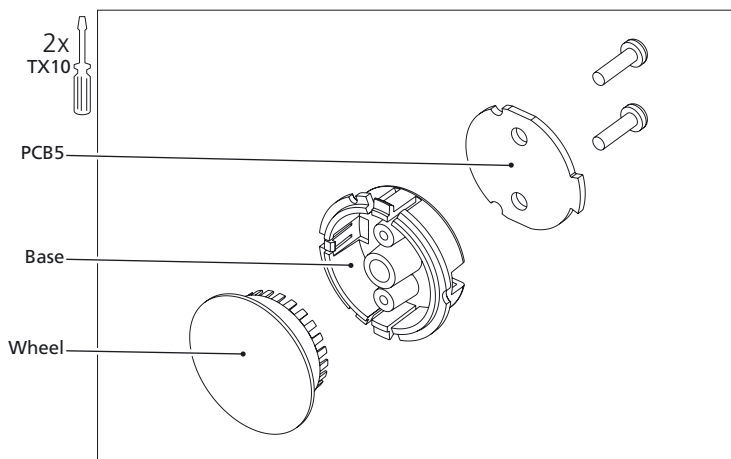

5.3 BeoSound 4 in Service Position

5.4 Remove Chassis

- Remove screws and release snaplock

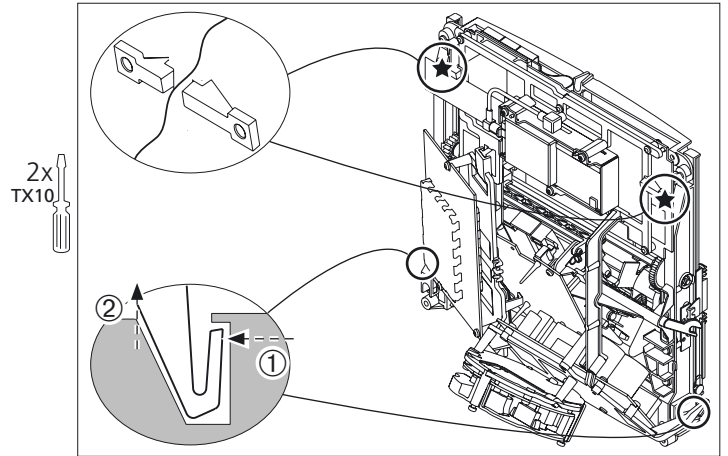

- Remove electrical chassis from mechanical chassis

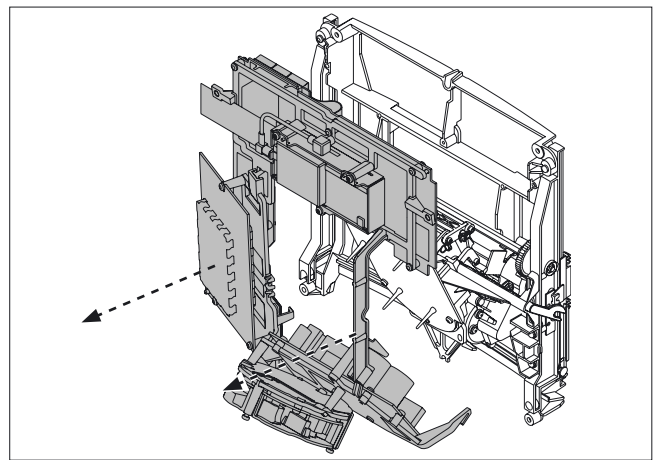

- Remove plugs

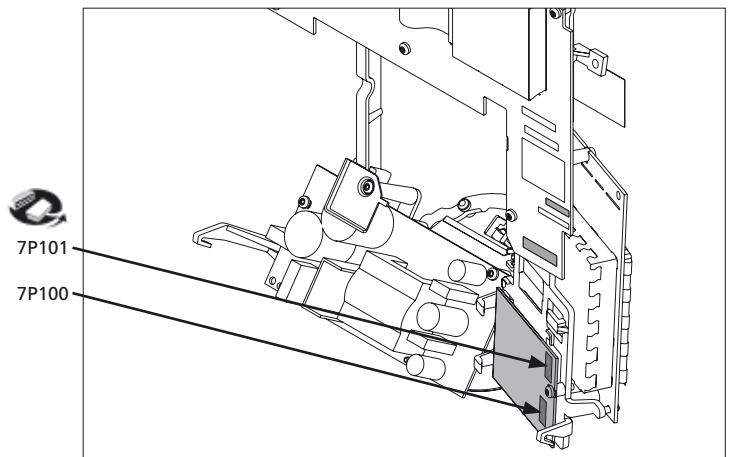

- Remove screw

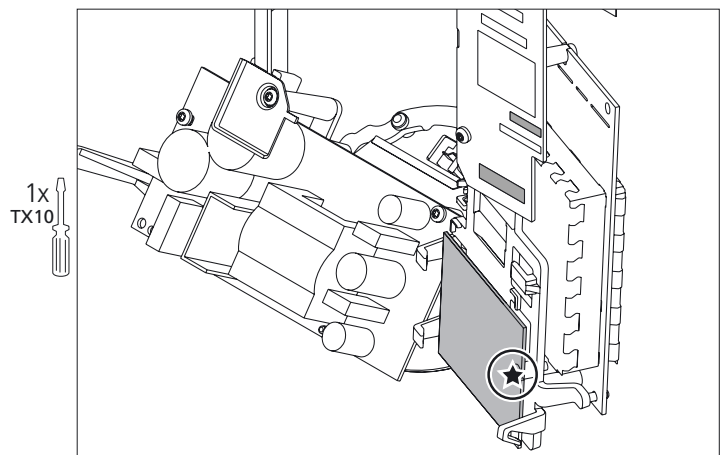

- ☞ 5.3 BeoSound 4 in Service Position
- ☞ 5.4 Remove Chassis
- ☞ 5.23 Remove Clamper unit
- Remove screws and plug

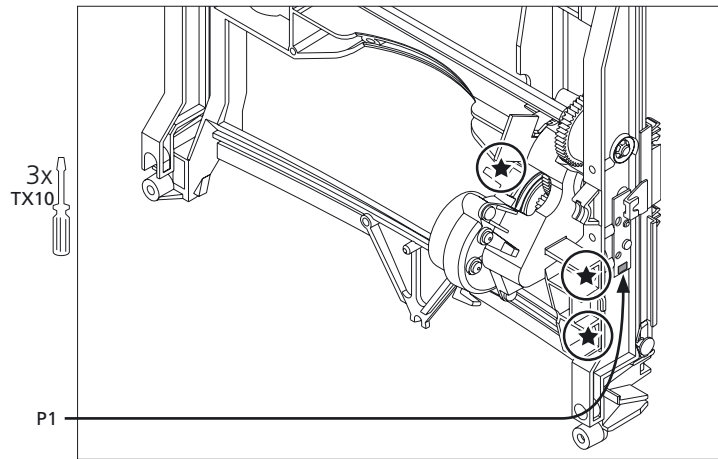

- Remove screws

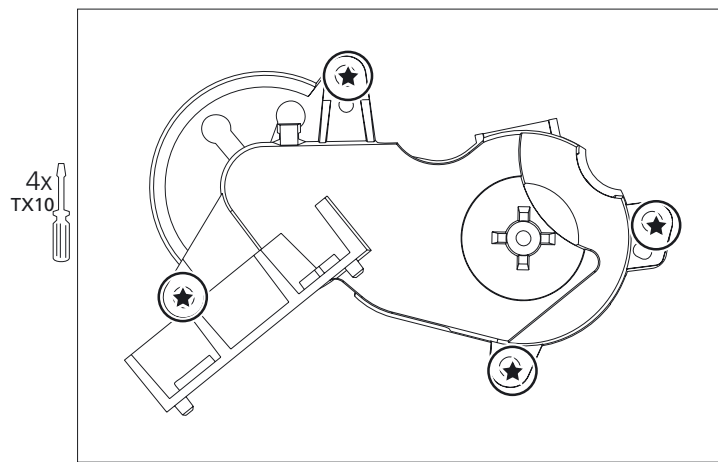

- Remove drive belt

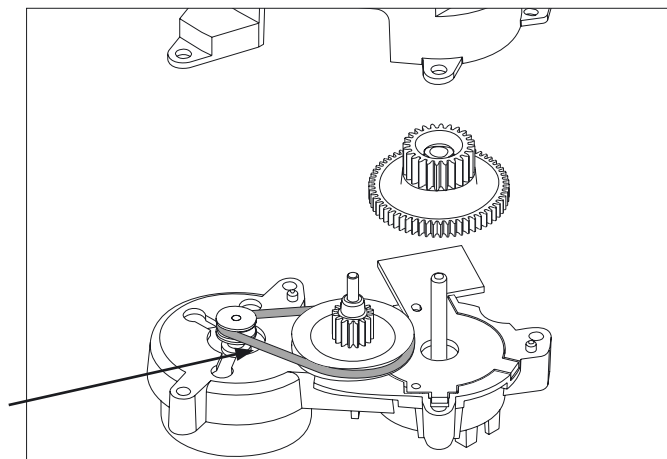

- Remove plug and gear wheel

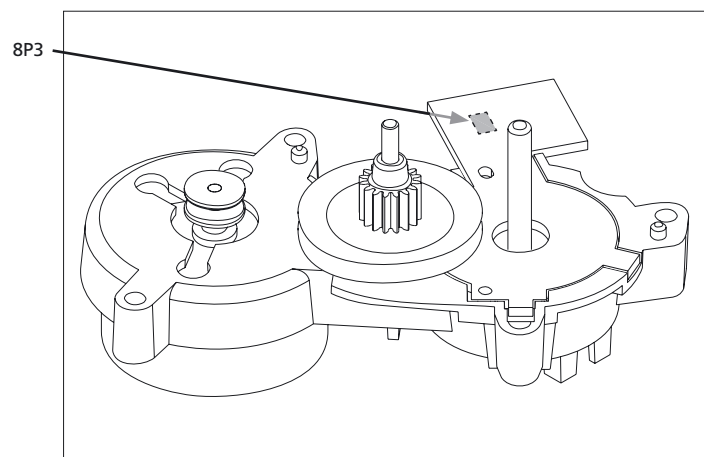

- ☞ 5.3 BeoSound 4 in Service Position
- ☞ 5.4 Remove Chassis
- ☞ 5.8 Remove PCB3, Magic
- Remove PCB9, Headphone

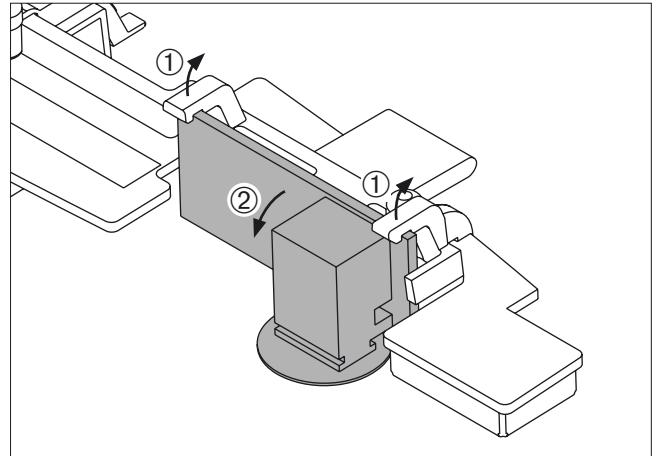

5.3 BeoSound 4 in Service Position

- Remove screws

3x
TX10

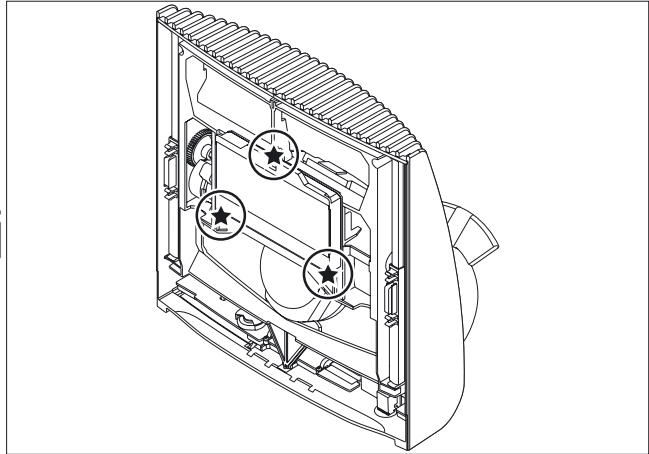

- Remove cable

Plug with lock!
CON1

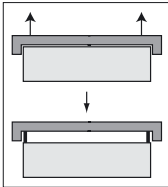

CON1

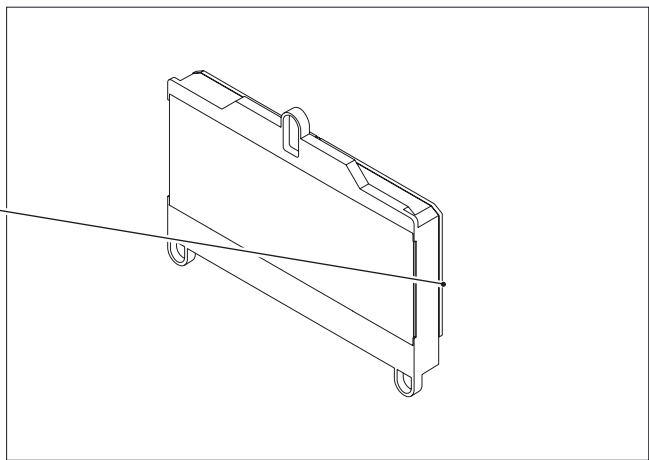

5.3 BeoSound 4 in Service Position

- Remove screws

2x
TX6

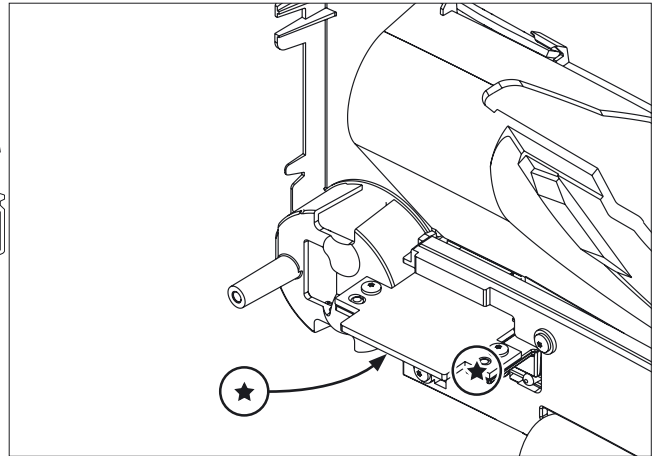

- Pull out PCB11, SD/MMC card reader

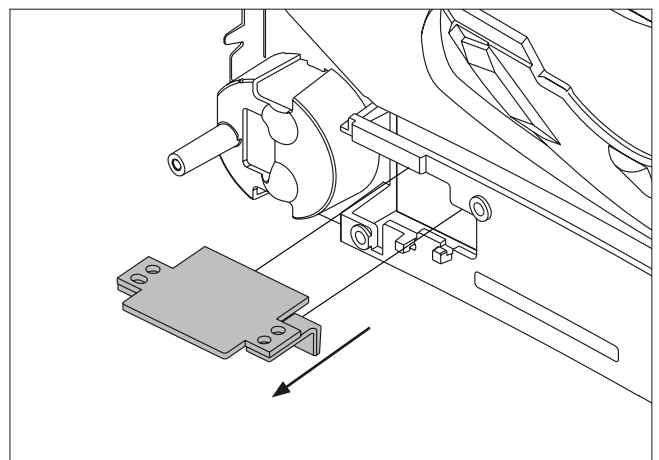

- 5.3 BeoSound 4 in Service Position
- 5.4 Remove Chassis
 - Remove screw

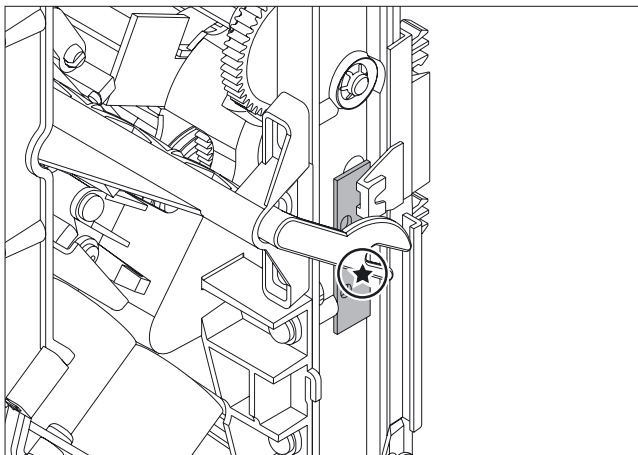

5.3 BeoSound 4 in Service Position

5.4 Remove Chassis

- Remove screws and release snaplock

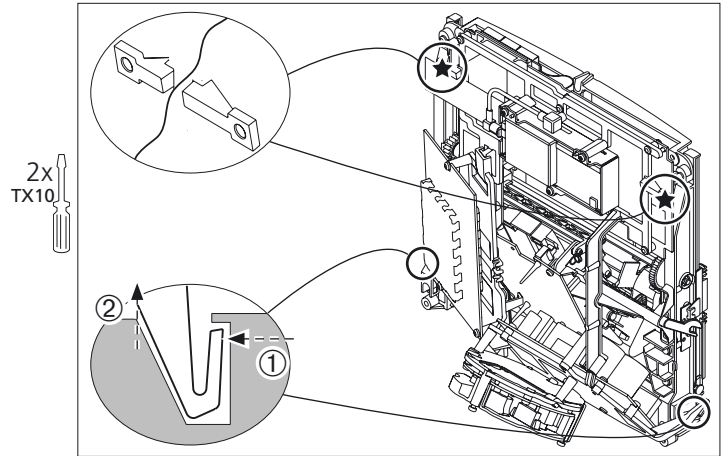

- Remove electrical chassis from mechanical chassis

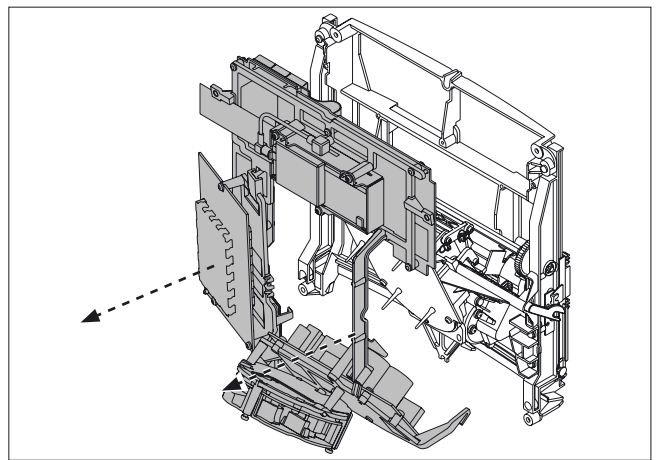

- Remove plugs

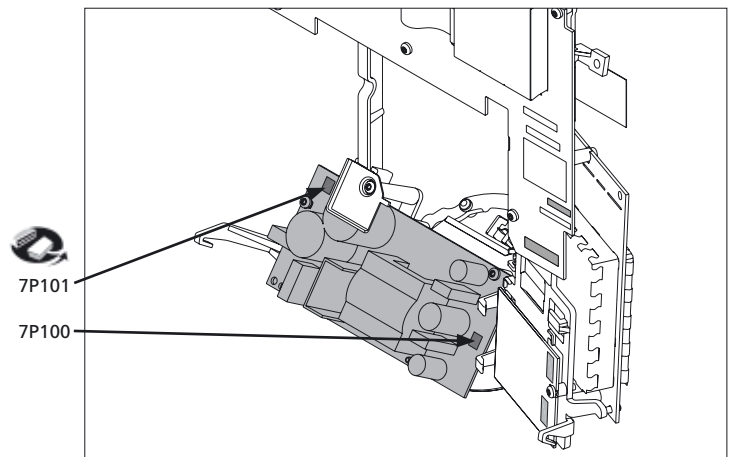

- Remove screws

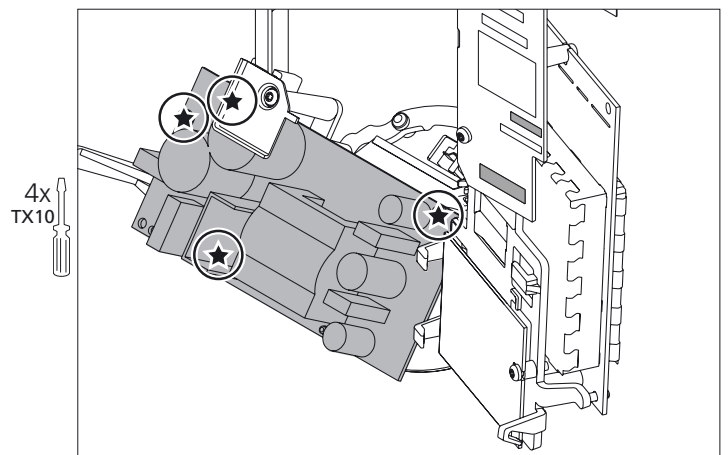

5.3 BeoSound 4 in Service Position

5.4 Remove chassis

- Remove screws

3x
TX10

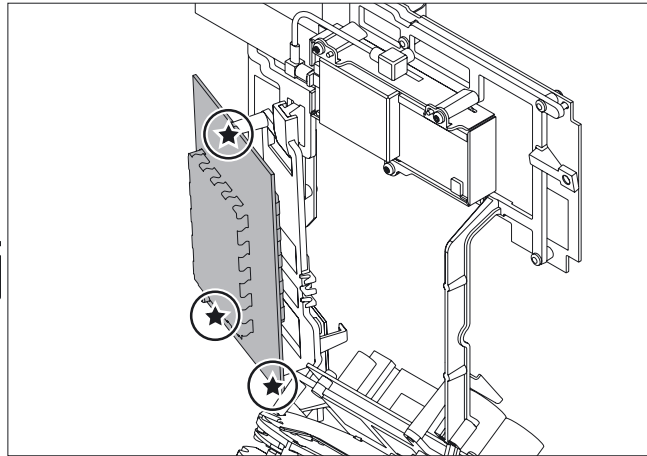

- Remove plugs on th back of PCB85

85P106
85P103
85P100

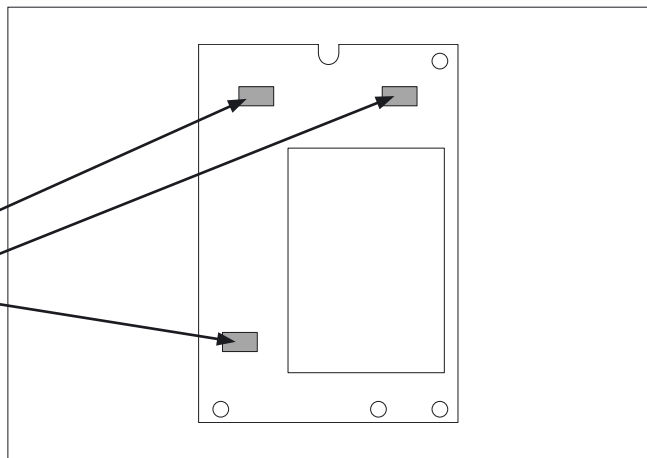

5.3 BeoSound 4 in Service Position

5.4 Remove Chassis

- Remove screws and release snaplock

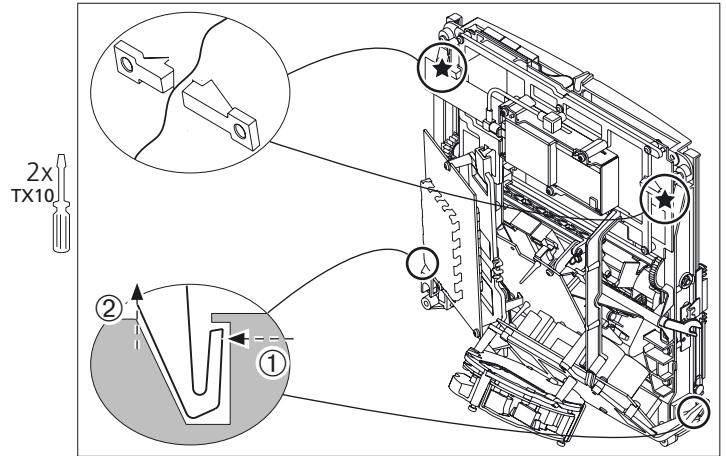

- Remove electrical chassis from mechanical chassis

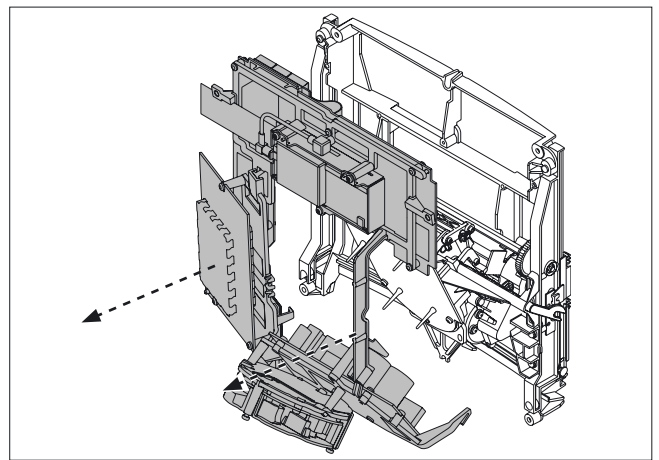

- Remove screws

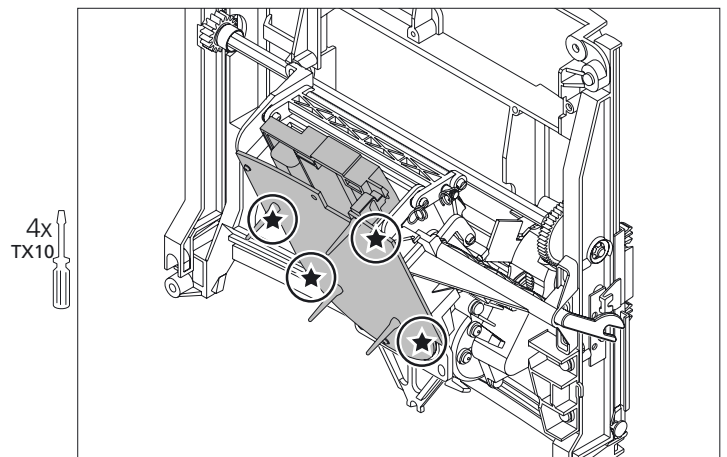

- Pull off CD unit

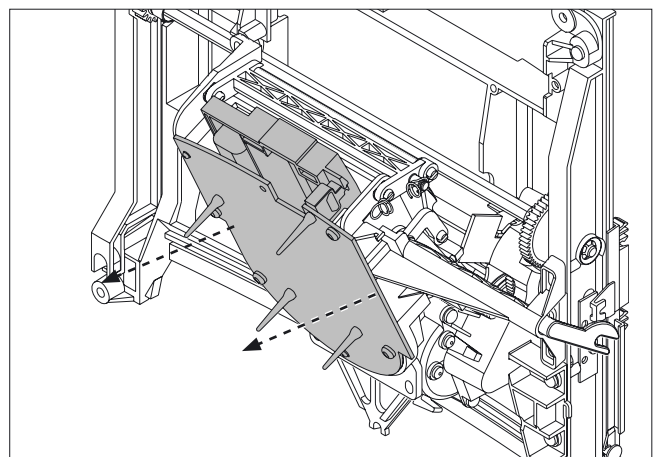

5.3 BeoSound 4 in Service Position

5.4 Remove chassis

- Remove plugs

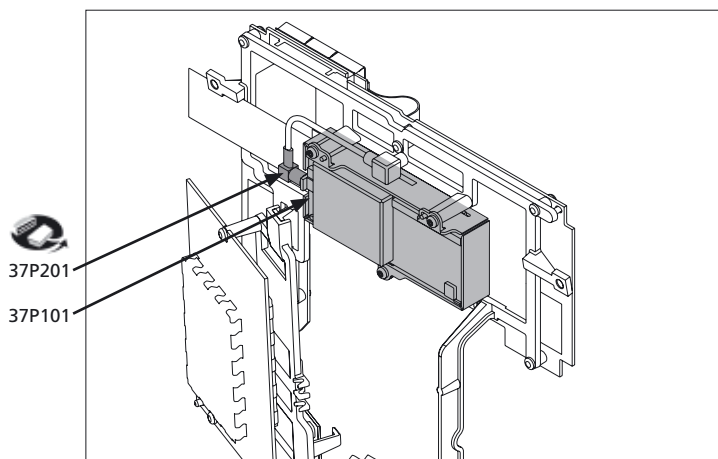

- Remove screws

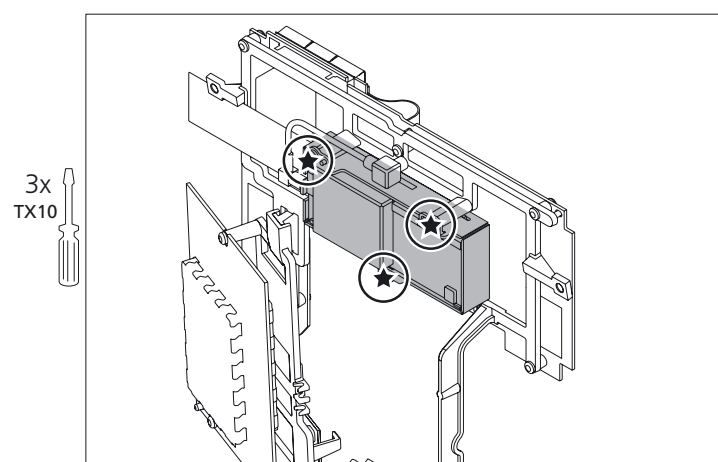

- ▣ 5.3 BeoSound 4 in Service Position
- ▣ 5.4 Remove Chassis
- ▣ 5.8 Remove PCB3, Magic
- ▣ 5.24 Remove Base

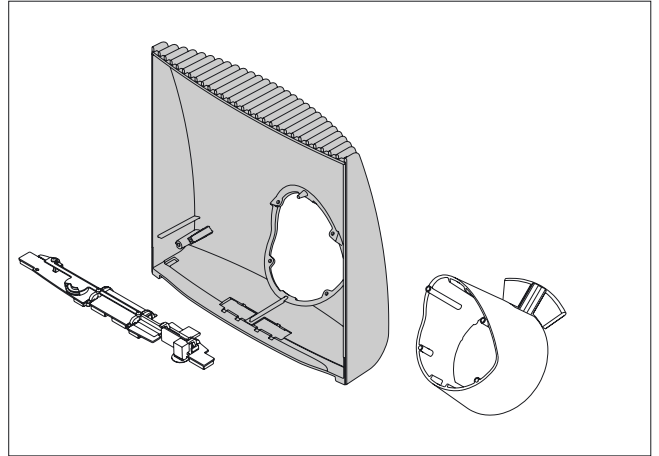

- 5.3 BeoSound 4 in Service Position
- 5.4 Remove Chassis
- 5.23 Remove Clamper unit
- Release snaplocks

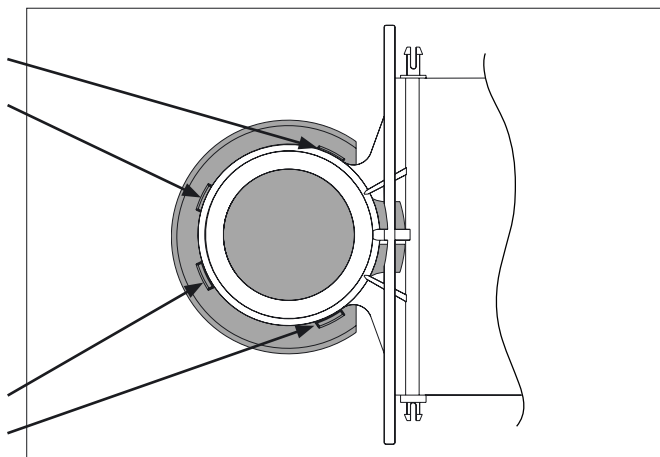

- ▣ 5.3 BeoSound 4 in Service Position
- ▣ 5.4 Remove Chassis
- ▣ 5.19 Remove CD unit
- Remove screws

4x
TX10

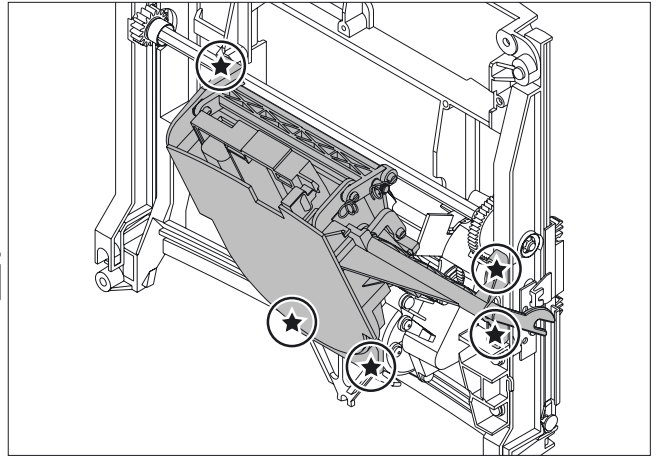
- Lift off clamper
- Note! Take care that the arm is placed correctly

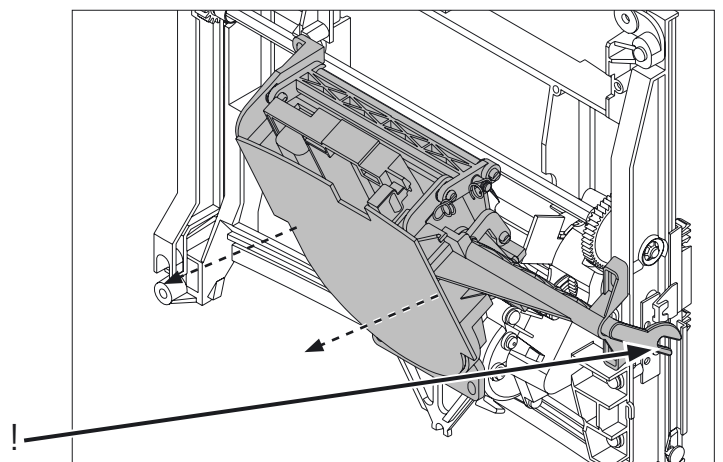

5.3 BeoSound 4 in Service Position

5.4 Remove Chassis

- Remove screws

4x
TX10

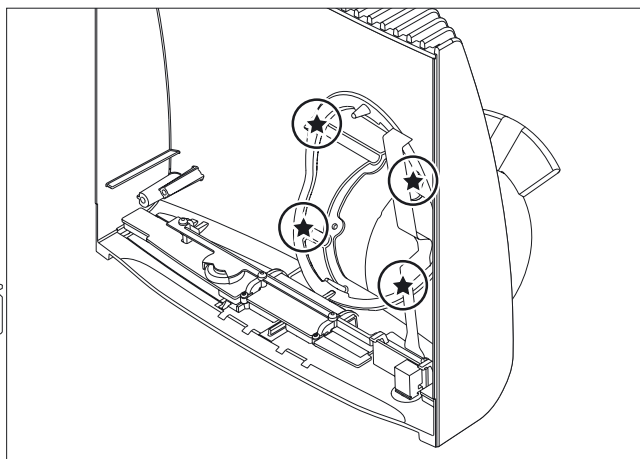

- ☞ 5.3 BeoSound 4 in Service Position
 - ☞ 5.4 Remove Chassis
 - ☞ 5.23 Remove Clamper unit
 - ☞ 5.12 Remove Motor unit
- Check that the alignment is correct

Scratch in the plastic

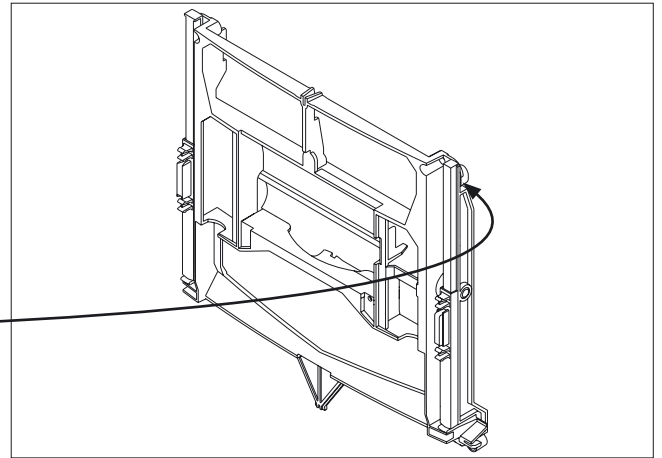
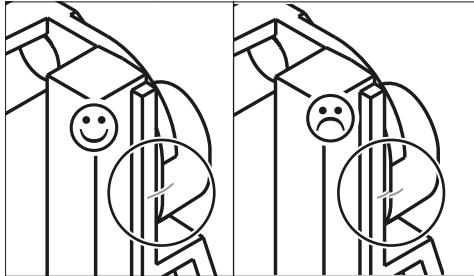

5.3 BeoSound 4 in Service Position

5.4 Remove Chassis

5.23 Remove Clamper unit

- Remove screws and plug

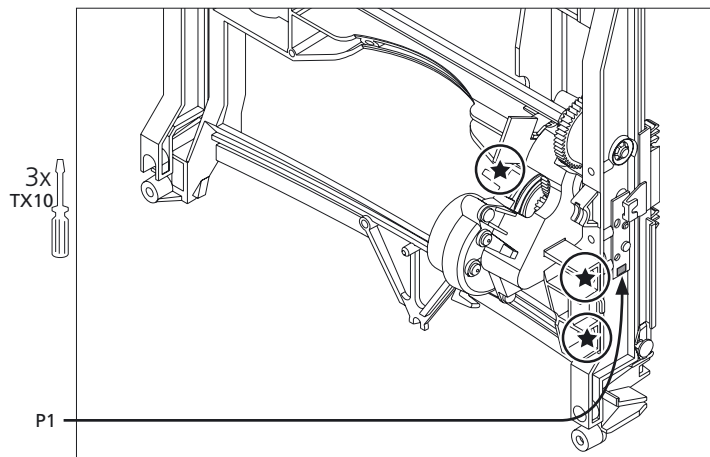

- Remove screws

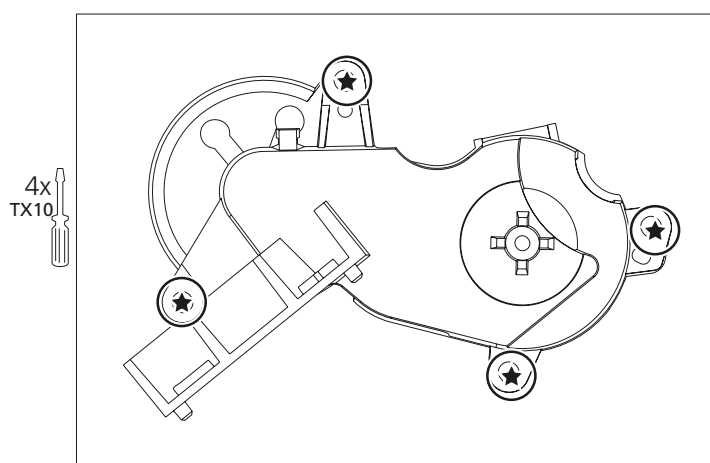

- Remove Drivebelt

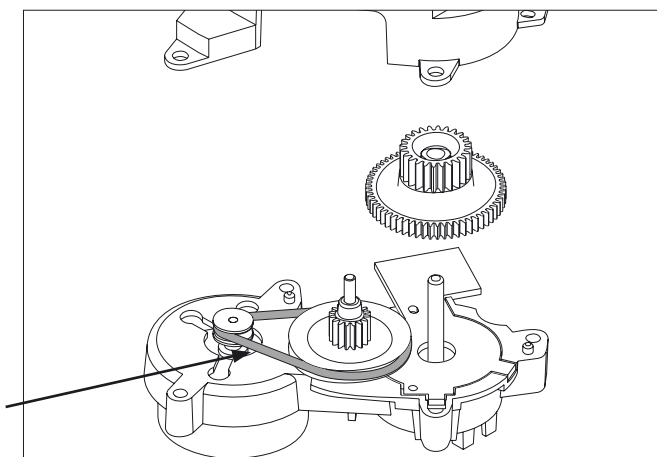

5.3 BeoSound 4 in Service Position

- Remove screws

4x
TX6

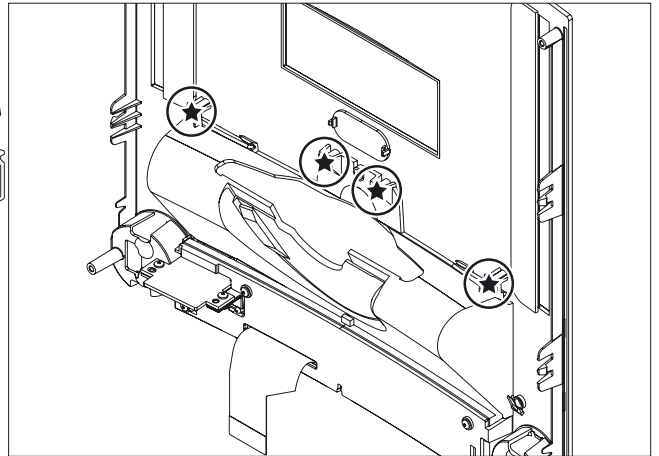

- Remove finger niche
Note: lift free of "lock"

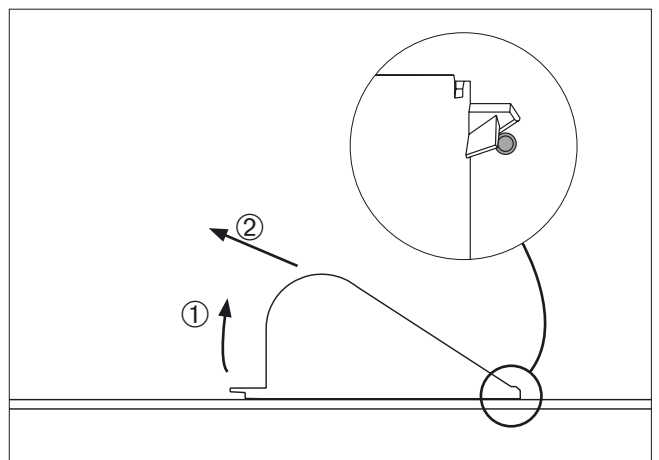

- ☞ 5.3 BeoSound 4 in Service Position
- ☞ 5.15 Remove SD/MMC card reader
- ☞ 5.27 Remove finger niche
- Remove cables

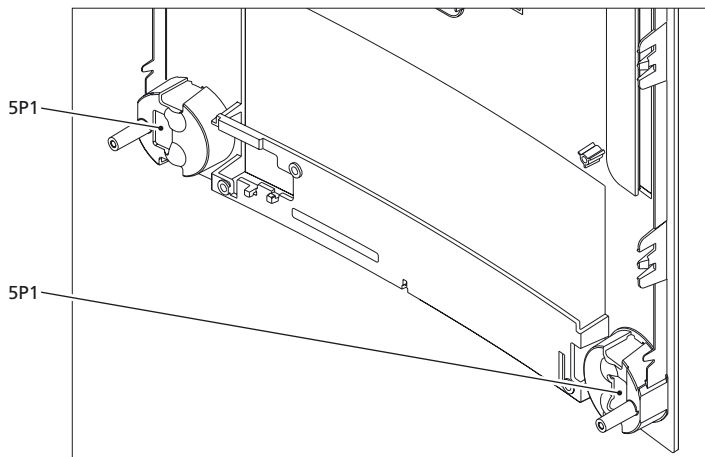

- Remove screws

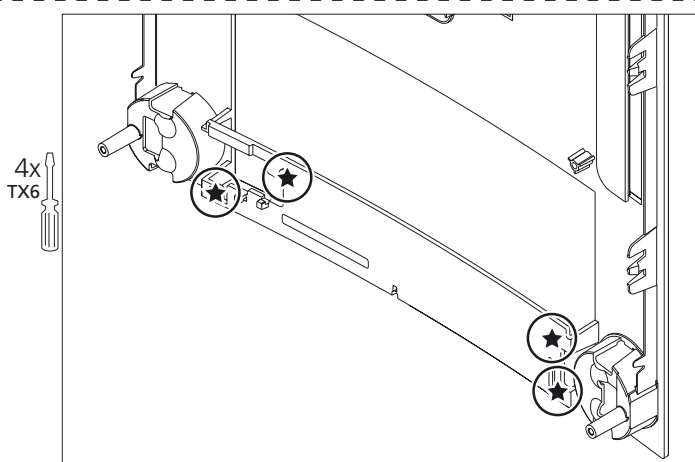

- Pull out keyboard

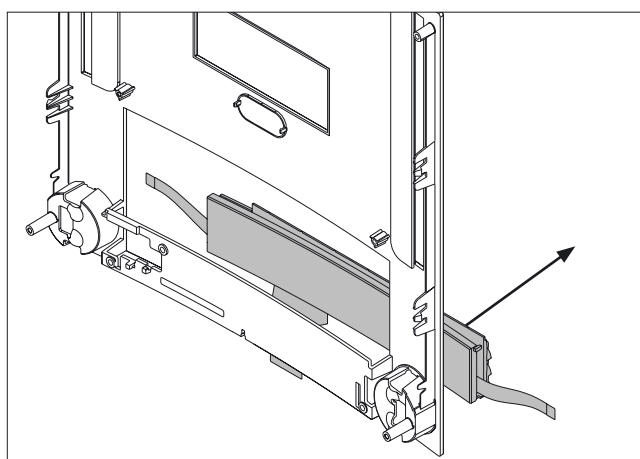

- 5.3 BeoSound 4 in Service Position
- 5.4 Remove Chassis
- 5.23 Remove Clamper unit
- Remove screws and plug

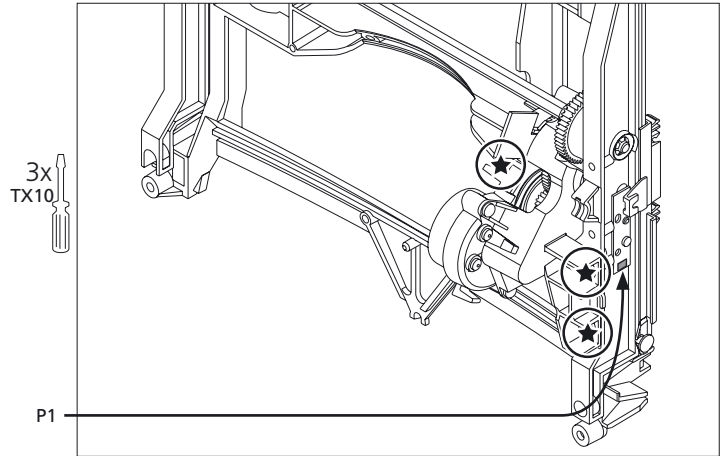

- Remove screws

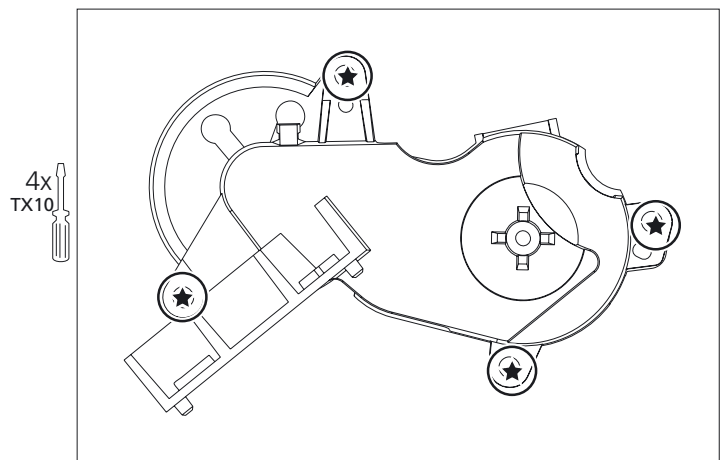

- Remove drivebelt

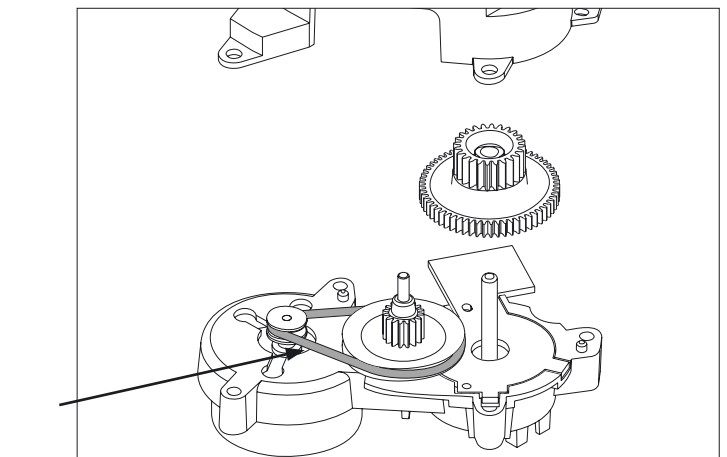

- Remove screws and plug

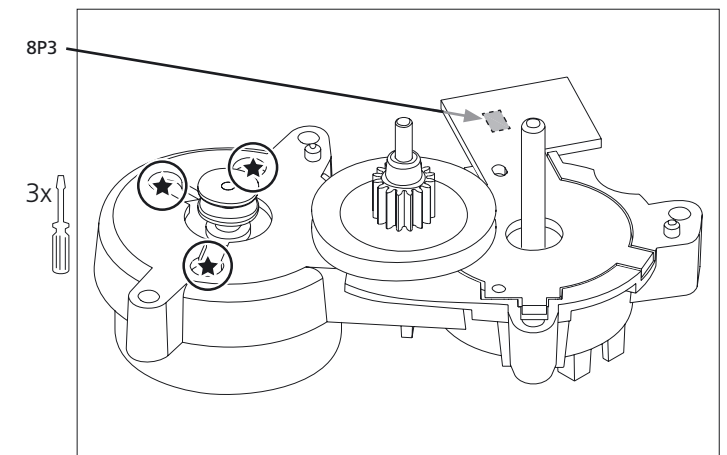

Specification guidelines for service use	BeoSound 4
With FM and RDS	Type 2851 EU 230V
	Type 2852 GB 230V
	Type 2853 US 120V
	Type 2854 JP 100V
	Type 2855 AUS 240V
	Type 2857 TWN 120V
	Type 2858 KOR 230V
	Type 2859 LAT 230V
	Type 2860 CHK 230V
Preamplifier section	
Intermod. distortion	≤0.1%, IHF
Frequency:	
AUX in	20Hz – 20kHz
Signal to Noise ratio:	
AUX, A-weighted, volume 80	≥90dB, typ. 97dB
Channel separation	≥50dB, typ. 63dB
Channel unbalance	≤±1dB
Tuner, FM section	
FM range – EU/US	87.5 – 108MHz
FM range for type 2854 – Japan	76 – 90MHz
Usable sensitivity mono	≤12dBf
50dB quieting sensitivity mono	≤20dBf
Signal-to-noise ratio mono	≥68dB, typ. 70dB
Signal-to-noise ratio stereo	≥62dB, typ. 65dB
Frequency response mono	30Hz – 15kHz, ±2dB
Frequency response Stereo	30Hz – 15kHz, ±2dB
RDS	PS-Name, RadioText, Clock
Tuner, DAB section	
Receiving bands	174 – 240MHz (band 3) 1452 – 1492MHz (band L)
Sensitivity (BER = 10e-4)	-95dBm
Adjacent channel rejection (BER = 10e-4)	35dB
Out of band rejection (BER = 10e-4)	45dB
Signal/noise ration (1kHz)	≥95dB
Frequency response 15 – 20000Hz	±1dB
Decoding	Up to 256kbit/s
Sampling	Half and full rate
IR operation	Beo4 recommended
CD player	
Playback	CD-DA, CD-R/RW, (Audio format only)
Testdisc	SBC 444A (part no. 3634064) SBC 429
CD, disc types	12cm (5"), 8cm (3")
Frequency response	20Hz – 20kHz ±1dB
Signal/noise ratio:	
Linear, below 80kHz	≥90dB / 76dB with volume 80
UNW	≥98dB / 90dB with volume 80
A-Weighted	≥103dB / 97dB with volume 80
Channel separation:	
1kHz	≥85dB
20Hz – 20kHz	≥75dB

Dynamic range (1kHz)	≥92dB
Channel unbalance (1kHz)	≤±1dB

THD+Noise:	
1kHz, 0 dBFS, volume 76	-85dB / -75dB with volume 76

SD Player/recorder

Storage media	Secure Digital cards (SD) MultiMediaCard (MMC) Or 100% SD SanDisk compatible
Capacity	All capacity
Audio Codec playback	MP3 format: Sampling frequencies: 8, 11.025, 12, 16, 22.05, 24, 32, 44.1 and 48kHz Constant or variable bit rates: 8, 16, 24, 32, 40, 48, 56, 64, 80, 96, 112, 128, 160, 192, 256 and 320Kbps WMA: Sampling frequencies: 8, 11.025, 16, 22.050, 32, 44.1 and 48kHz Bit rates: 64, 80, 96, 128, 160 and 192Kbps
Audio codec recording format	MP3 format CBR @128kbit/s in stereo 44.1kHz sample frequency ≥16 bit sample resolution

Testdisc: SBC429, Bitrate: 128kbit/sec, Codec: MPEG 1 Layer 3

Frequency response:	
Recorded from CD, fs = 44.1kHz	20Hz – 15kHz ±1dB

Signal/noise ratio:	
LINEAR, below 80kHz	≥76dB
UNW	≥90dB
A-Weighted	≥97dB

Dimensions

W x H x D	280 x 310 x 240mm / 11.0 x 12.2 x 9.4 in
Weight	4kg
Cabinet finish	Smoke coloured glass
Power consumption	Stby. 1W, typical 12W

Accessories

Floorstand	Type 2180
Wall brackets	Type 2181

Connections

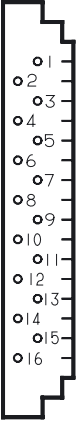
	Master Link x 1	Pin 1	Data- -0.25V
		Pin 2	Data+ +0.25V
		Pin 3	ML sense 0 – 5V
		Pin 4-8	NC
		Pin 9	ATI/Tx
		Pin 10	ATI/Rx
		Pin 11	Supply voltage -7V > -15V, stby. -3V > -15V
		Pin 12	Supply voltage 7V >15V, stby. 3V >15V
		Pin 13	Audio L- 1V bal., Rin 2.2MΩ Rout 75Ω
		Pin 14	Audio L+ 1V bal., Rin 2.2MΩ Rout 75Ω
		Pin 15	Audio R- 1V bal., Rin 2.2MΩ Rout 75Ω
		Pin 16	Audio R+ 1V bal., Rin 2.2MΩ Rout 75Ω

Audio Aux Input/Output x 1	AUX in L/R	Phono 2V RMS 22 – 47kΩ
	AUX out L/R	Phono 1.3V RMS ±0.2 <1kΩ

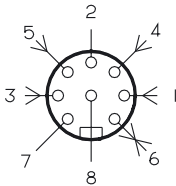
	Pin 1	PL ON = >2.5V, OFF = <0.5V
	Pin 2	Signal GND
	Pin 3	Audio L out 0V to 2V RMS
	Pin 4	PL speaker ON = >2.5V, OFF = <0.5V
	Pin 5	Audio R out 0V to 2V RMS
	Pin 6	Data: High >3.5V. Low <0.8V
	Pin 7	Data GND
	Pin 8	Not used

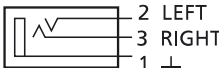
Headphones x 1	 	Sound level experienced should be the same using Form 1 headphones and BeoLab 4000 speakers
----------------	---	---

Output level, -0dBFS, volume 72, Rl 33Ω	Max 1.4VRMS
Signal/Noise ratio, A-weighted, -0dBFS, vol. 72	≥92dB without clipping

FM Aerial x 1	75Ω impedance
---------------	---------------

DAB aerial x 1	75Ω impedance
----------------	---------------

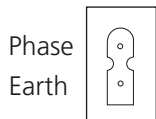
Mains 	Cable included
	187 – 264V, 50 – 60Hz Type: 2851, 2852, 2855, 2858, 2859, 2860 58 – 132V, 50 – 60 Hz Type: 2853, 2854, 2857

Subject to change without notice

Wiring diagram

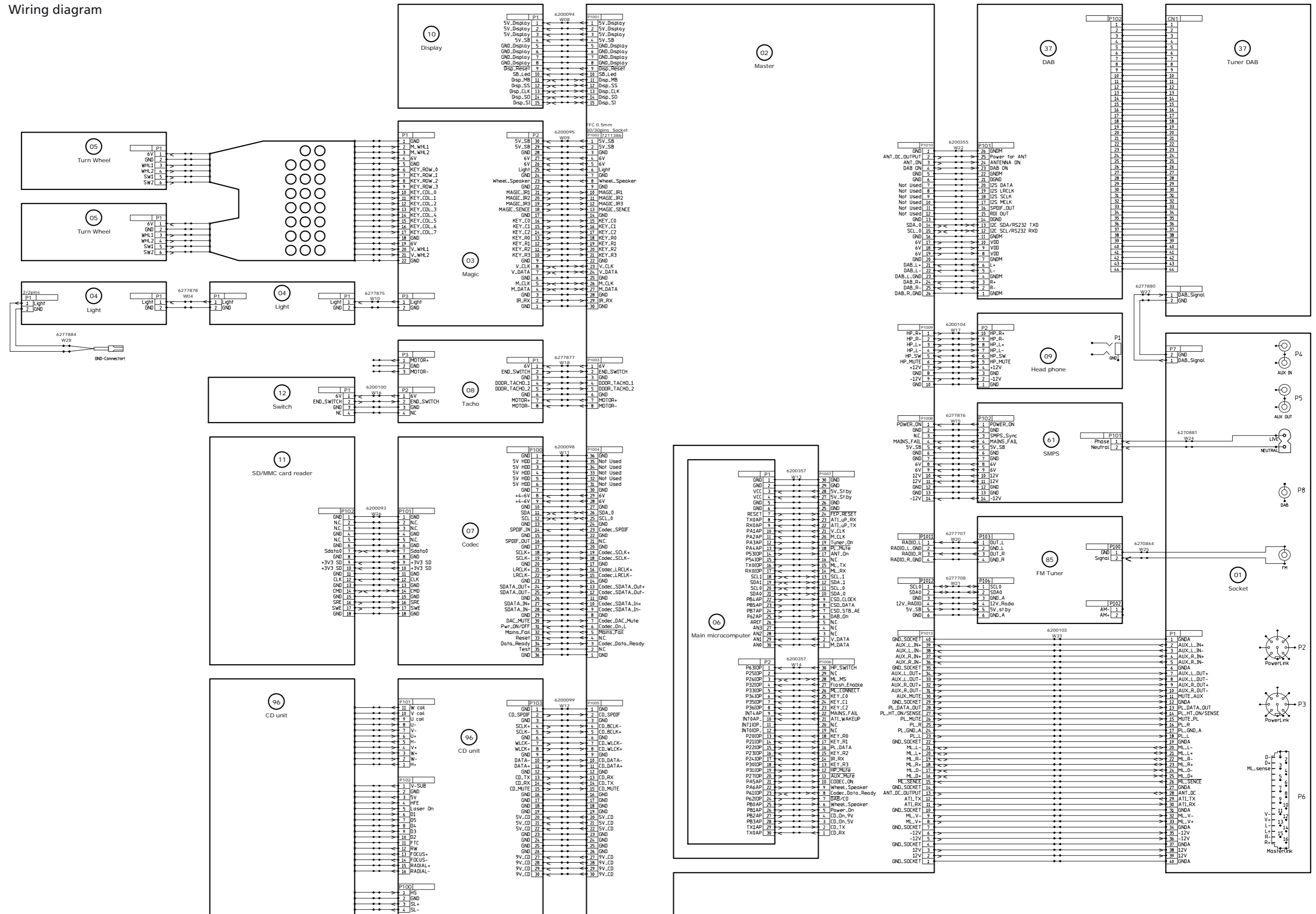

Available parts
BeoSound 4

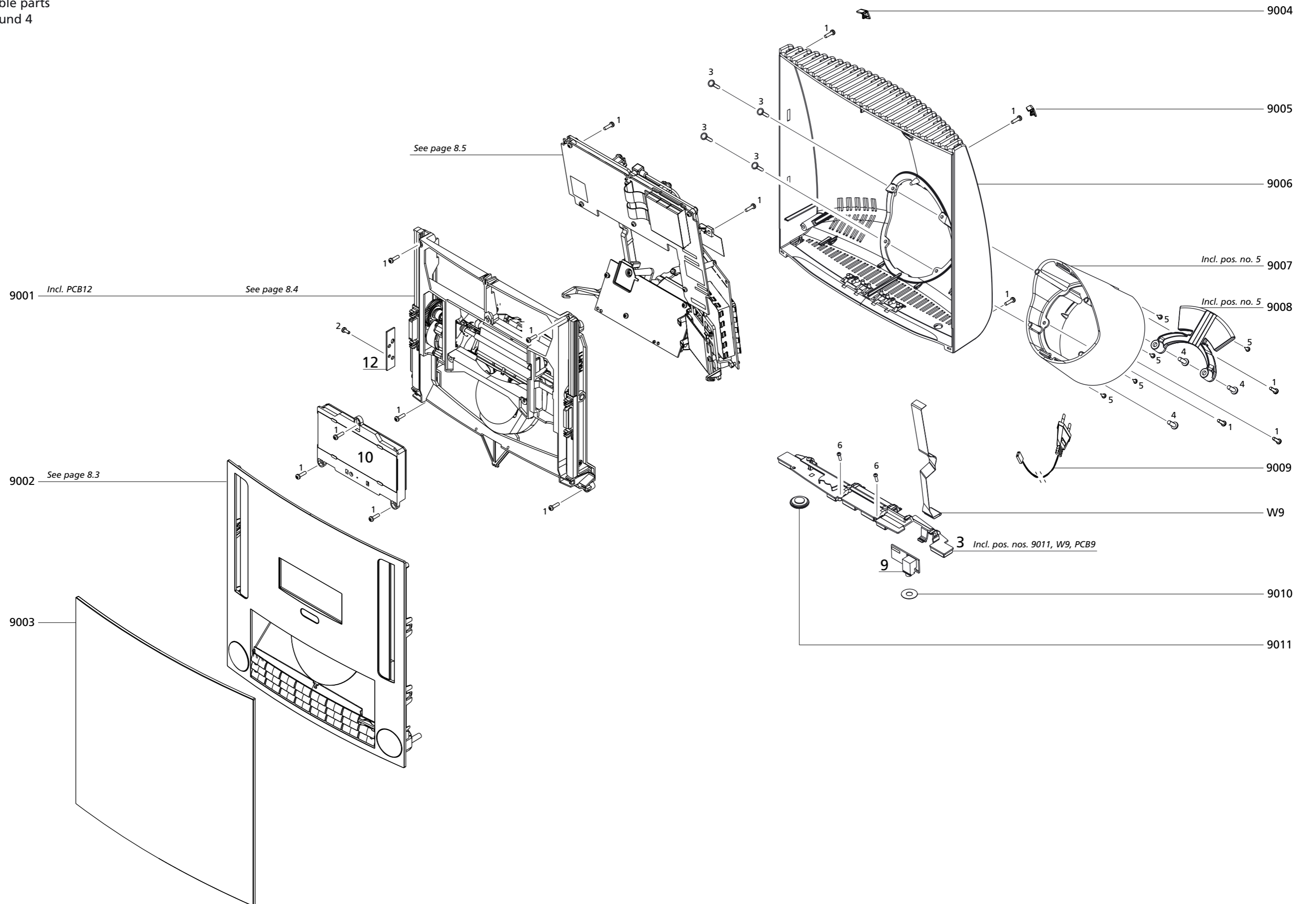

BeoSound 4

9001	3110018	Movable mechanics incl. PCB12
9002	3162231	Front
9003	3162228	Glass
9004	3341017	Screw cover, left
9005	3341014	Screw cover, right
9006	3430045	Cabinet
9007	3103136	Base incl. pos. no. 5
9008	3151913	Wire guide incl. pos. no. 5
9009	6100079	Mains cable EU/LAT
	6100084	Mains cable UK
	6100247	Mains cable JP
	6100248	Mains cable AUS
	6100306	Mains cable US/TWN
	6100089	Mains cable CHINA
	6100386	Mains cable KOR
9010	3333050	Packing f/headphone
9011	8480389	Dynamic speaker

W9	6200095	Wire 30 pole
----	---------	--------------

3Module	3110016	PCB3, Magic incl. pos. nos. 9011, W9, PCB9
---------	---------	--

9Module	8002412	PCB9, Headphone
---------	---------	-----------------

10Module	8337004	PCB10, Display
----------	---------	----------------

12Module	8002400	PCB12, Switch
----------	---------	---------------

Screws etc.

1	2052011	Screw 3 x 10mm
2	2052029	Screw 2 x 5mm
3	2054011	Screw 3 x 16mm
4	2019035	Screw 4 x 12mm
5	3103274	Rubber foot
6	2011048	Screw 2.5 x 8mm

Front

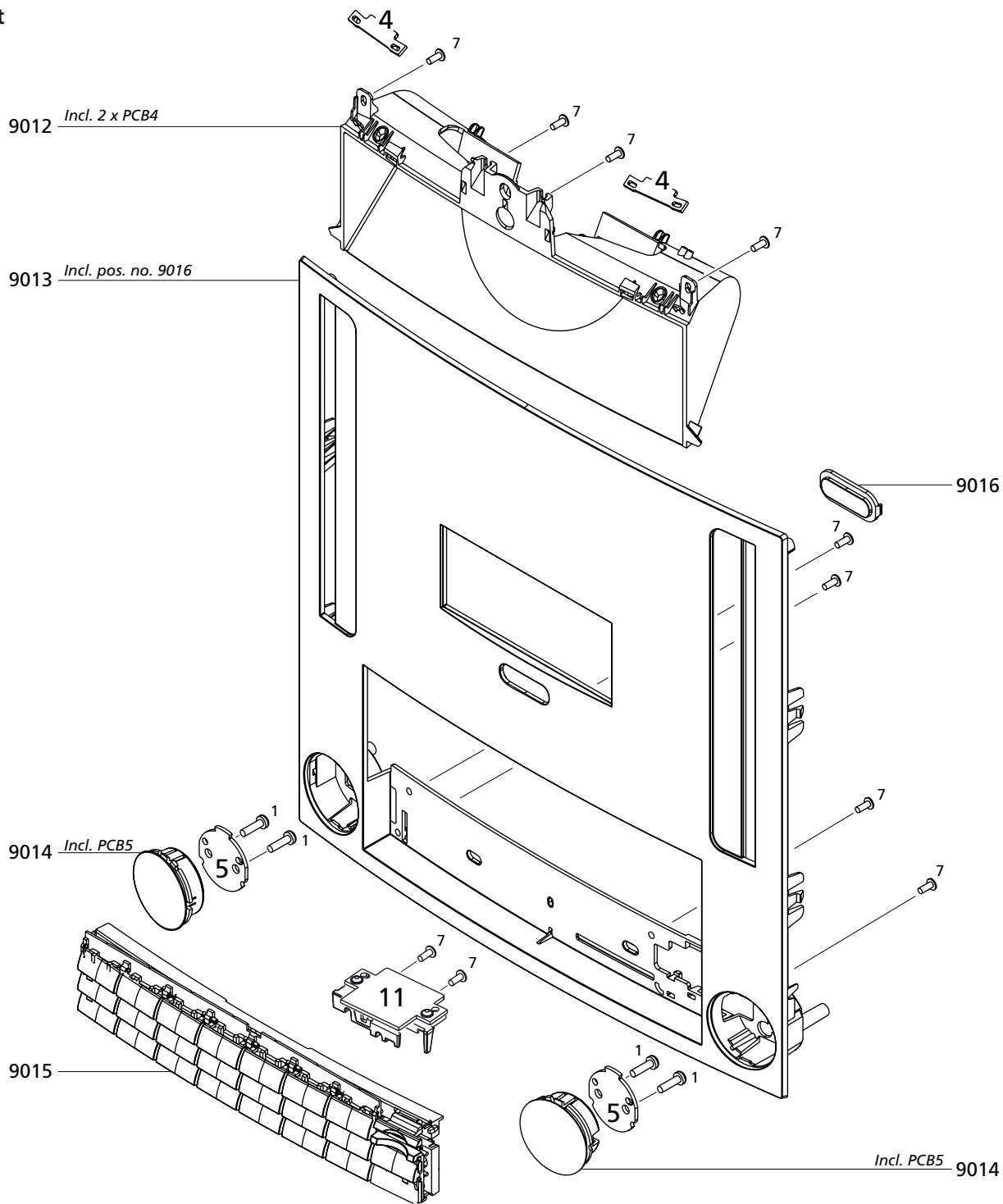

9012	3162232	Finger niche incl. 2 x PCB4
9013	3162233	Front cover incl. pos. no. 9016
9014	2791022	Set of wheels incl PCB5
9015	3167040	Keyboard
9016	3162217	Cover

4Module 8002409 PCB4, Light

5Module 8002410 PCB5, Turn wheel

11Module 8002405 SD/MMC card reader

Screws

1	2052011	Screw 3 x 10mm
7	2013034	Screw 6 x 25mm

CD unit and Motor

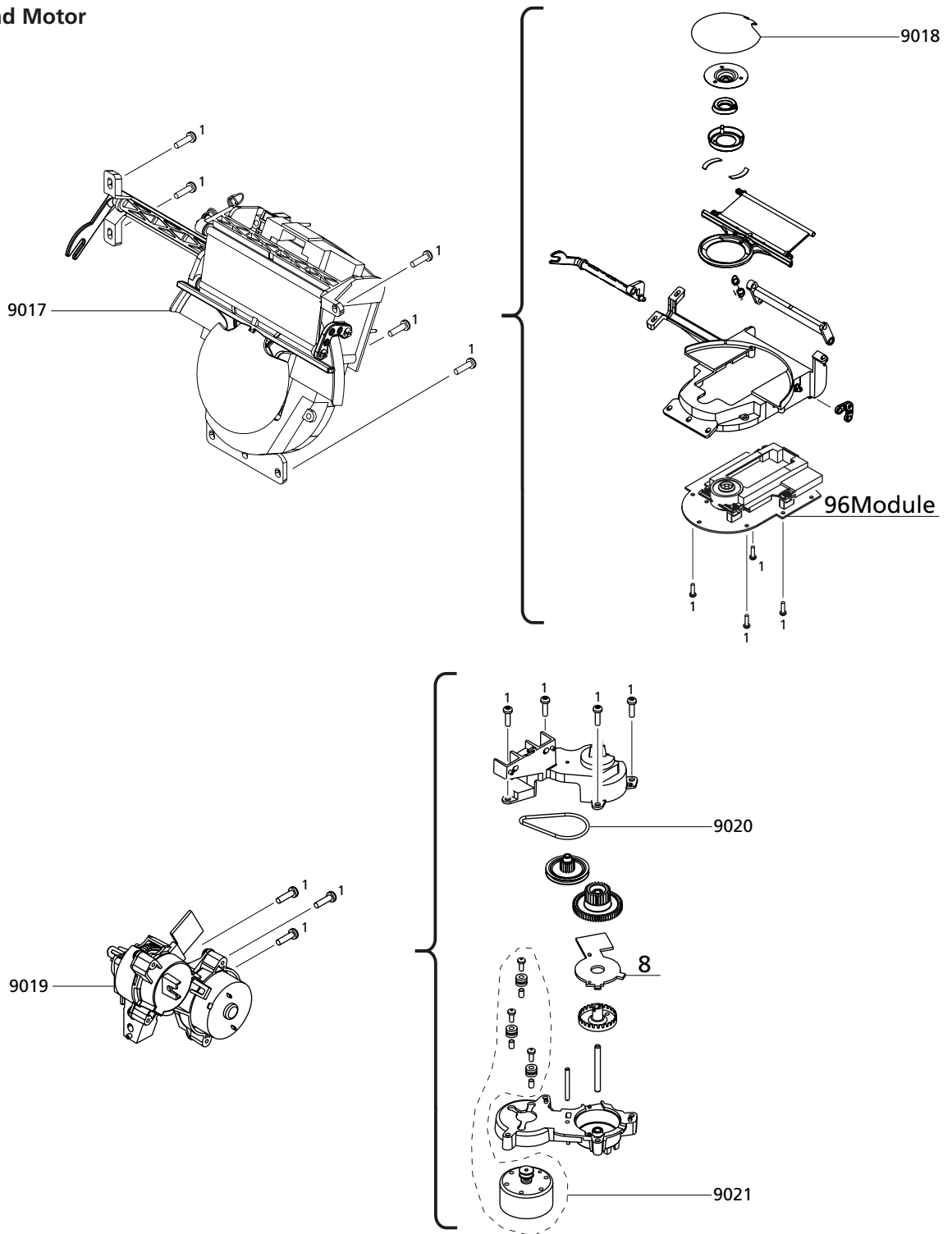

9017	3320949	CD unit
9018	3162230	Clamber cover
9019	2755082	Gear unit
9020	2732127	Belt
9021	8400025	Motor

8Module	8002530	PCB, Tacho
---------	---------	------------

96Module	8420024	CD unit
----------	---------	---------

Screws

1	2052011	Screw 3 x 10mm
---	---------	----------------

Electrical chassis

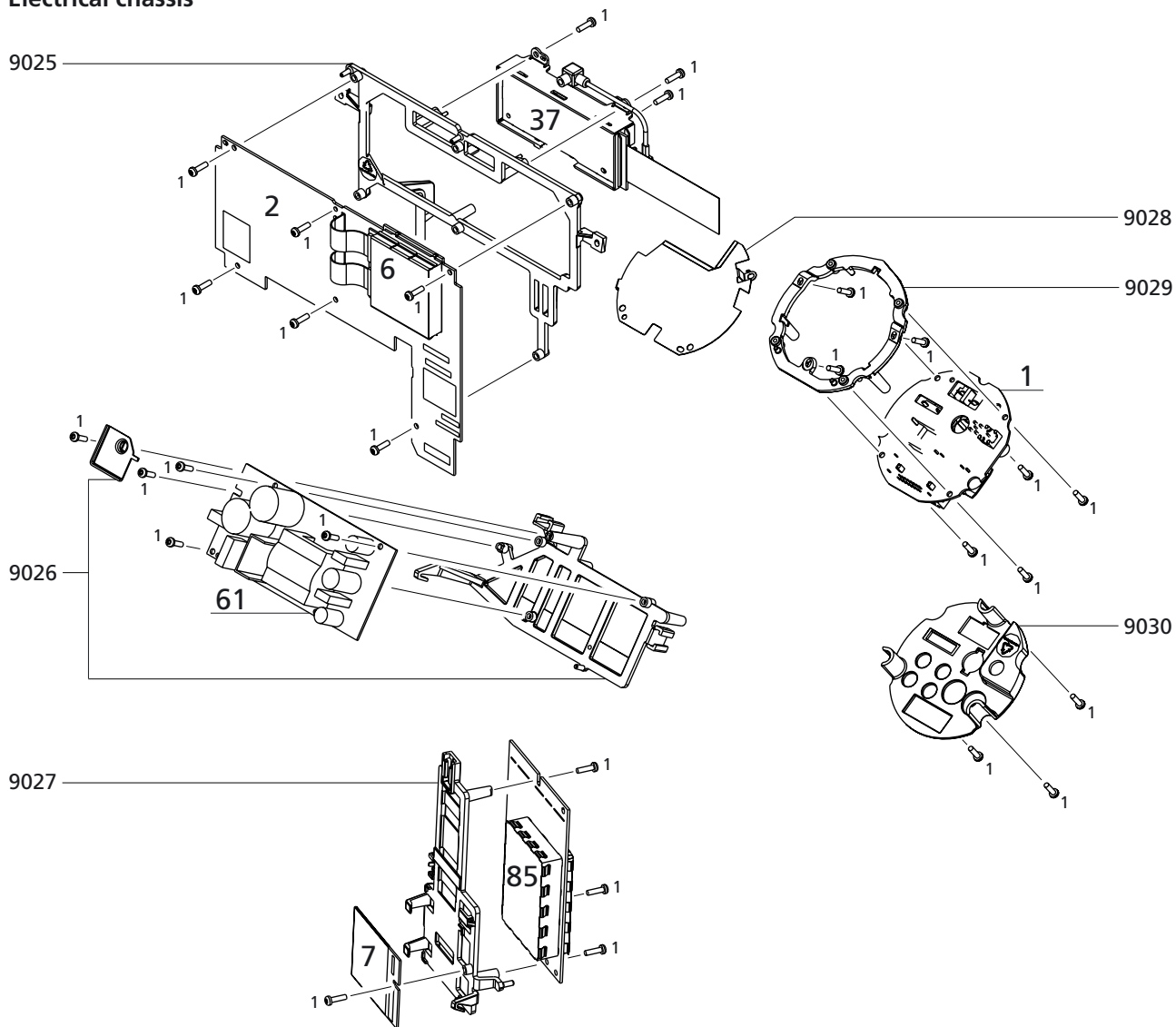

9025	3110010	Holder f/PCB2 and PCB37
9026	3110012	Holder f/PCB61
9027	3110011	Holder f/PCB7 and PCB85
9028	2570016	Ground connector
9029	3110013	Holder f/PCB1
9030	3160344	Cover
1Module	8002592	PCB1, Socket
2Module	8002593	PCB2, Master incl. PCB6
6Module	8000138	PCB6, Main microprocessor
		SW IC
	8343712	EEPROM
7Module	8002595	PCB7, Codec
37Module	8002046	DAB
61Module	8002594	PCB61, SMPS
	7221406	Shunt
85Module	8002415	PCB85, FM tuner EU
	8002417	PCB85, FM tuner JP
1	2052011	Screw 3 x 10mm

Screws

Wire bundles

See wiring diagram page 7.1.
The part no. is printed on the diagram above the wire bundle, as shown.

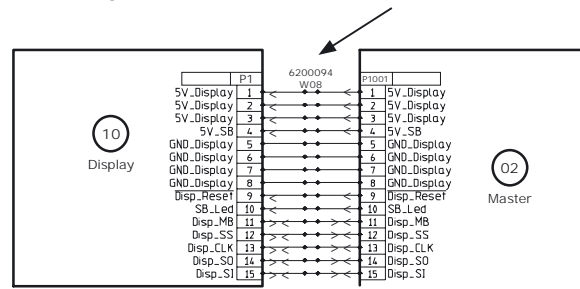

Parts not shown

- 3395296 Back-up suitcase
- 3375490 Product cover
- 3634031 Test CD - SBC 444A
- 3624018 Du Pont Polishing Cloth

ServiceTool

- 3375055 P.I.T. box
- ServiceTool – download from Retail System / BeoWise
- 3375397 Cable kit for ServiceTool, complete
- Cable kit consists of:
- 6270857 Main cable
- 6270852 Cable D-SUB-Jack
- 6277439 Wire, 3 pole
- 8008922 Minijack f/STB-Controller

Available documentation

See Retail Ordering System

Accessories

- 8720063 FM dipol antenna
- 8720044 DAB antenna

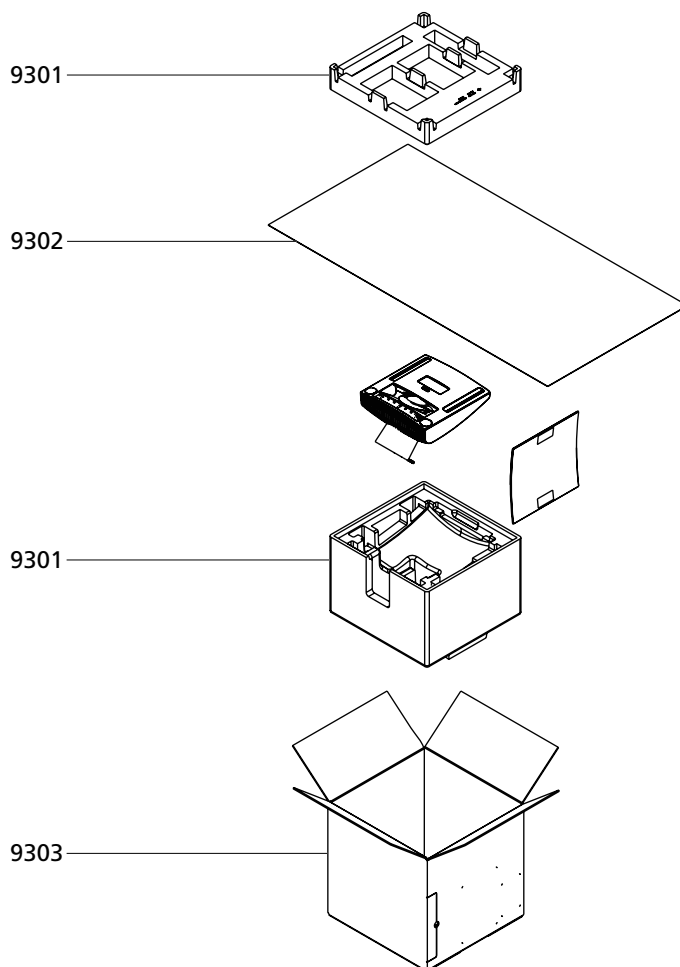
Packing

9301	3396308	Foam, set of top and bottom
9302	3917143	Foam foil
9303	3392385	Outer carton

Floor Stand 2180

1218011

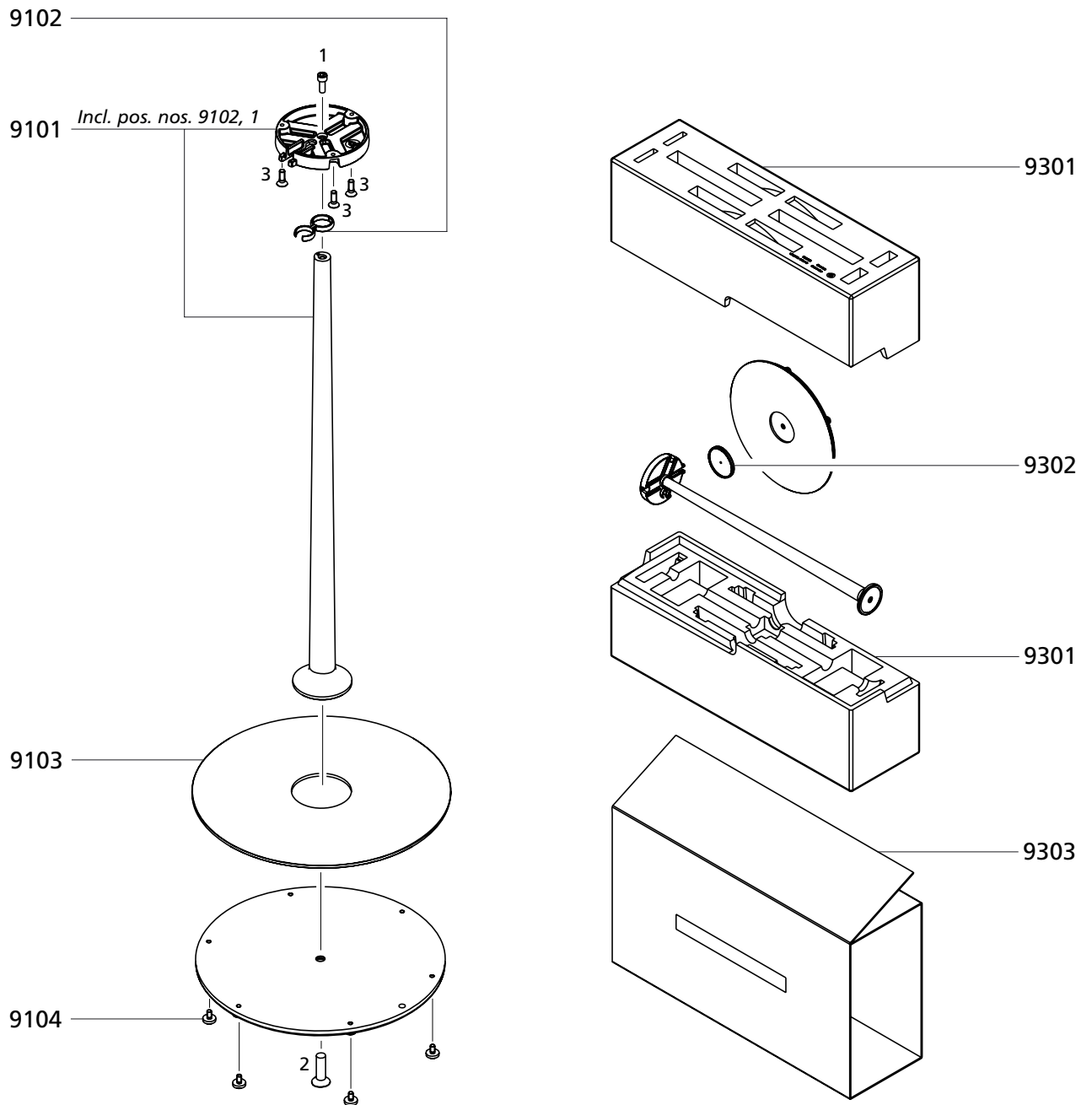

9101	3932012	Tube incl. pos. nos. 9102, 1
9102	2369003	Cable clip
9103	3162237	Cover plate
9104	3103391	Rubber foot

1	2046017	Screw 6 x 16mm
2	3390065	Bag w/parts
3	2019035	Screw 4 x 12mm

9301	3396329	Foam packing, set
9302	3016011	Guide f/cover plate
9303	3392485	Outer carton

3390083	Cable manager
3507399	Guide
3507661	Guide f/cable manager

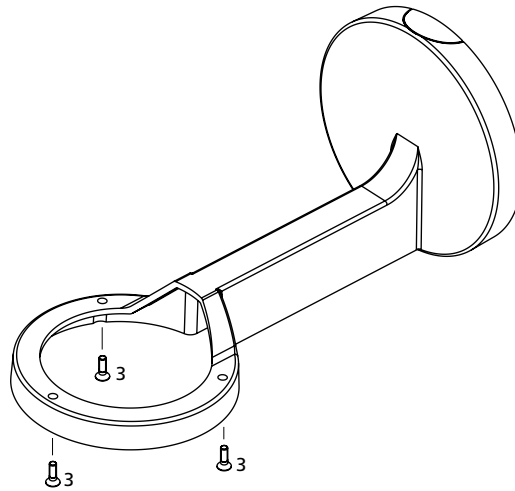
Wall bracket 2181
1218111

3	2019035	Screw 4 x 12mm
---	---------	----------------

	3390071	Bag w/parts
	3507400	Guide

Bang & Olufsen
DK-7600 Struer
Denmark

Phone +45 96 84 11 22*
Fax +45 97 85 39 11

3538035 04-06