

# HCD-GTR33/GTR55/GTR77

## SERVICE MANUAL

E Model

Ver. 1.0 2010.03



Photo: HCD-GTR77 (E4 Model)

- HCD-GTR33 is the amplifier, USB, CD player, tuner and tape deck (only E4 model) section in MHC-GTR33.
- HCD-GTR55 is the amplifier, USB, CD player, tuner and tape deck (only E4 model) section in MHC-GTR55.
- HCD-GTR77 is the amplifier, USB, CD player, tuner and tape deck (only E4 model) section in MHC-GTR77.

“WALKMAN” and “WALKMAN” logo are registered trademarks of Sony Corporation.

MICROVAULT is a trademark of Sony Corporation.

MPEG Layer-3 audio coding technology and patents licensed from Fraunhofer IIS and Thomson.

Windows Media is a registered trademark of Microsoft Corporation in the United States and/or other countries.

“Memory Stick” is a trademark of Sony Corporation.

CD Section	Model Name Using Similar Mechanism	HCD-GTZ4/GTZ4i/GTZ5
	CD Mechanism Type	CDM88BL-DVBU101
	Optical Pick-up Name	KHM-313CAB/C2NP
Tape Section (Only for E4 model)	Model Name Using Similar Mechanism	HCD-GT111/GT222/GT444/GT555
	Tape mechanism Type	CS-21SC-900TP

### SPECIFICATIONS

#### Amplifier section

##### MHC-GTR77

The following are measured at Mexican model:

AC 127 V, 60 Hz

Other models:

AC 120 V, 220 V, 240 V, 50/60 Hz

Front/Satellite Speaker

Power Output (rated):

120 W + 120 W (at 6 Ω, 1 kHz, 1% THD)

Front Speaker

RMS output power (reference):

225 W + 225 W (per channel at 8 Ω, 1 kHz)

Satellite Speaker

RMS output power (reference):

100 W + 100 W (per channel at 24 Ω, 1 kHz)

Subwoofer

RMS output power (reference):

130 W + 130 W (12 Ω, 100 Hz)

##### MHC-GTR55

The following are measured at Mexican model:

AC 127 V, 60 Hz

Other models:

AC 120 V, 220 V, 240 V, 50/60 Hz

Front Speaker

Power Output (rated):

110 W + 110 W (at 6 Ω, 1 kHz, 1% THD)

RMS output power (reference):

240 W + 240 W (per channel at 6 Ω, 1 kHz)

Subwoofer

RMS output power (reference):

240 W (6 Ω, 100 Hz)

##### MHC-GTR33

The following are measured at Mexican model:

AC 127 V, 60 Hz

Other models:

AC 120 V, 220 V, 240 V, 50/60 Hz

Front Speaker

Power Output (rated):

75 W + 75 W (at 6 Ω, 1 kHz, 1% THD)

RMS output power (reference):

165 W + 165 W (per channel at 6 Ω, 1 kHz)

Subwoofer

RMS output power (reference):

160 W (6 Ω, 100 Hz)

#### Inputs

PC (AUDIO IN) L/R

Voltage 700 mV, impedance 47 kilohms

MIC

Sensitivity 1 mV, impedance 10 kilohms

⚡ (USB) port: Type A

#### Outputs

PHONES

Accepts headphones of 8 Ω or more

#### USB section

Supported bit rate

MP3 (MPEG 1 Audio Layer-3):

32 kbps – 320 kbps, VBR

WMA: 48 kbps – 192 kbps

AAC: 48 kbps – 320 kbps

Sampling frequencies

MP3 (MPEG 1 Audio Layer-3):

32 kHz/44.1 kHz/48 kHz

WMA: 44.1 kHz

AAC: 44.1 kHz

Transfer speed

Full-Speed

Supported USB device

Mass Storage Class

Maximum current

500 mA

#### Disc player section

System

Compact disc and digital audio system

Laser Diode Properties

Emission Duration: Continuous

Laser Output\*: Less than 44.6 μW

\* This output is the value measurement at a distance of 200 mm from the objective lens surface on the Optical Pick-up Block with 7 mm aperture.

Frequency response

20 Hz – 20 kHz

Signal-to-noise ratio

More than 90 dB

Dynamic range

More than 88 dB

#### Tape deck section (For African model only)

Recording system

4-track 2 channel, stereo

#### Tuner section

FM stereo, FM/AM superheterodyne tuner

##### FM tuner section

Tuning range

North American models:

87.5 MHz – 108.0 MHz (100 kHz step)

Other models:

87.5 MHz – 108.0 MHz (50 kHz step)

Antenna

FM lead antenna

Antenna terminals

75 ohms unbalanced

Intermediate frequency

10.7 MHz

##### AM tuner section

Tuning range

Pan American and Oceanian models:

530 kHz – 1,710 kHz (with 10 kHz tuning interval)

531 kHz – 1,710 kHz (with 9 kHz tuning interval)

Other models:

530 kHz – 1,610 kHz (with 10 kHz tuning interval)

531 kHz – 1,602 kHz (with 9 kHz tuning interval)

Antenna

AM loop antenna, external antenna terminal

Intermediate frequency

450 kHz

#### General

Power requirements

Oceanian model: AC 230 V – 240 V,

50/60 Hz

Mexican model: AC 127 V, 60 Hz

Argentina model: AC 220 V, 50/60 Hz

Other models: AC 120 V, 220 V or

230 V – 240 V, 50/60 Hz, Adjustable with

voltage selector

Power consumption

MHC-GTR77: 260 W

MHC-GTR55: 250 W

MHC-GTR33: 280 W

Dimensions (w/h/d) (excl. speakers)

(Approx.)

231 mm × 361 mm × 429.5 mm

Mass (excl. speakers) (Approx.)

African and Pan Asian models:

HCD-GTR77/HCD-GTR55: 10.7 kg

HCD-GTR33: 10.5 kg

Other models:

HCD-GTR77/HCD-GTR55: 10.2 kg

HCD-GTR33: 10.0 kg

Design and specifications are subject to change

without notice.

• Abbreviation

E4 : African model

## COMPACT DISC DECK RECEIVER

9-890-541-01

2010C08-1

© 2010.03

Sony Corporation

Audio & Video Business Group

Published by Sony EMCS (Malaysia) PG Tec

# SONY®

## NOTES ON CHIP COMPONENT REPLACEMENT

- Never reuse a disconnected chip component.
- Notice that the minus side of a tantalum capacitor may be damaged by heat.

## FLEXIBLE CIRCUIT BOARD REPAIRING

- Keep the temperature of soldering iron around 270 °C during repairing.
- Do not touch the soldering iron on the same conductor of the circuit board (within 3 times).
- Be careful not to apply force on the conductor when soldering or unsoldering.

## SAFETY CHECK-OUT

After correcting the original service problem, perform the following safety check before releasing the set to the customer:

Check the antenna terminals, metal trim, “metallized” knobs, screws, and all other exposed metal parts for AC leakage.

Check leakage as described below.

## LEAKAGE TEST

The AC leakage from any exposed metal part to earth ground and from all exposed metal parts to any exposed metal part having a return to chassis, must not exceed 0.5 mA (500 microamperes.). Leakage current can be measured by any one of three methods.

1. A commercial leakage tester, such as the Simpson 229 or RCA WT-540A. Follow the manufacturers’ instructions to use these instruments.
2. A battery-operated AC milliammeter. The Data Precision 245 digital multimeter is suitable for this job.
3. Measuring the voltage drop across a resistor by means of a VOM or battery-operated AC voltmeter. The “limit” indication is 0.75 V, so analog meters must have an accurate low-voltage scale. The Simpson 250 and Sanwa SH-63Trd are examples of a passive VOM that is suitable. Nearly all battery operated digital multimeters that have a 2 V AC range are suitable. (See Fig. A)

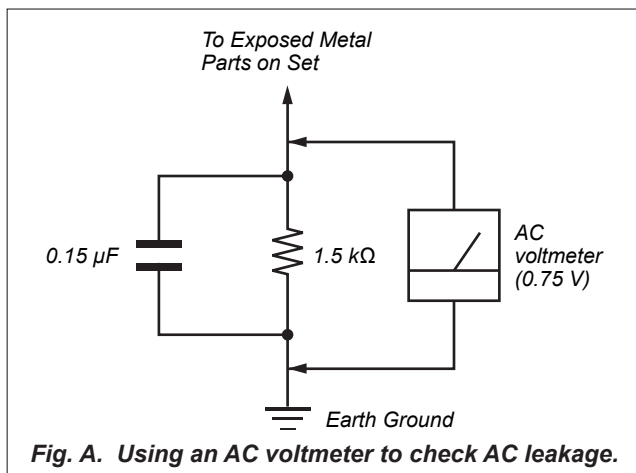

### CAUTION

Use of controls or adjustments or performance of procedures other than those specified herein may result in hazardous radiation exposure.

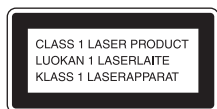

This appliance is classified as a CLASS 1 LASER product. This marking is located on the rear exterior.

### SAFETY-RELATED COMPONENT WARNING!

COMPONENTS IDENTIFIED BY MARK  $\triangle$  OR DOTTED LINE WITH MARK  $\triangle$  ON THE SCHEMATIC DIAGRAMS AND IN THE PARTS LIST ARE CRITICAL TO SAFE OPERATION. REPLACE THESE COMPONENTS WITH SONY PARTS WHOSE PART NUMBERS APPEAR AS SHOWN IN THIS MANUAL OR IN SUPPLEMENTS PUBLISHED BY SONY.

## TABLE OF CONTENTS

<b>1. SERVICING NOTES</b> .....	3
<b>2. DISASSEMBLY</b>	
2-1. Disassembly Flow.....	5
2-2. Case (Side-L/R).....	5
2-3. Top Case.....	6
2-4. Tape Mechanism Deck.....	6
2-5. Front Panel Block, HUB Board, DMB19 Board.....	7
2-6. DC Fan (M101), Back Panel.....	7
2-7. MAIN Board.....	8
2-8. POWER Board.....	8
2-9. Chassis Section.....	9
2-10. CD Mechanism Block (CDM88B-DVBU101).....	9
2-11. Optical Pick-up Block (KHM-313CAB).....	10
2-12. Belt (DLM3A).....	10
<b>3. TEST MODE</b> .....	11
<b>4. MECHANICAL ADJUSTMENTS</b> .....	13
<b>5. ELECTRICAL CHECK</b> .....	14
<b>6. DIAGRAMS</b>	
6-1. Block Diagram - RF SERVO, USB Section -.....	15
6-2. Block Diagram - MAIN Section -.....	16
6-3. Block Diagram - AMP Section -.....	17
6-4. Block Diagram - PANEL, POWER SUPPLY Section -.....	18
6-5. Printed Wiring Board - DMB19 Board -.....	20
6-6. Schematic Diagram - DMB19 Board (1/3) -.....	21
6-7. Schematic Diagram - DMB19 Board (2/3) -.....	22
6-8. Schematic Diagram - DMB19 Board (3/3) -.....	23
6-9. Printed Wiring Board - MAIN Board -.....	24
6-10. Schematic Diagram - MAIN Board (1/3) -.....	25
6-11. Schematic Diagram - MAIN Board (2/3) -.....	26
6-12. Schematic Diagram - MAIN Board (3/3) -.....	27
6-13. Printed Wiring Board - HUB Board -.....	28
6-14. Schematic Diagram - HUB Board -.....	29
6-15. Printed Wiring Board - POWER Board -.....	30
6-16. Schematic Diagram - POWER Board -.....	31
6-17. Printed Wiring Board - DISPLAY Board -.....	32
6-18. Schematic Diagram - DISPLAY Board -.....	33
6-19. Printed Wiring Board - MIC, USB AND VOLUME Board -.....	34
6-20. Schematic Diagram - MIC, USB AND VOLUME Board -.....	35
6-21. Printed Wiring Board - TC Board -.....	36
6-22. Schematic Diagram - TC Board -.....	36
6-23. Printed Wiring Board - TRANS Board -.....	37
6-24. Schematic Diagram - TRANS Board -.....	38
<b>7. EXPLODED VIEWS</b>	
7-1. Case Section.....	49
7-2. Top Panel Section.....	50
7-3. Loading Panel Section, HUB Board Section, DMB19 Board Section.....	51
7-4. DISPLAY Board Section.....	52
7-5. Front Panel Section.....	53
7-6. Back Panel Section.....	54
7-7. MAIN Board Section.....	55
7-8. Chassis Section.....	56
7-9. CD Mechanism Section (CDM88B-DVBU101).....	57
<b>8. ELECTRICAL PARTS LIST</b> .....	58

## SECTION 1 SERVICING NOTES

### NOTES ON HANDLING THE OPTICAL PICK-UP BLOCK OR BASE UNIT

The laser diode in the optical pick-up block may suffer electrostatic break-down because of the potential difference generated by the charged electrostatic load, etc. on clothing and the human body. During repair, pay attention to electrostatic break-down and also use the procedure in the printed matter which is included in the repair parts.

The flexible board is easily damaged and should be handled with care.

### NOTES ON LASER DIODE EMISSION CHECK

The laser beam on this model is concentrated so as to be focused on the disc reflective surface by the objective lens in the optical pickup block. Therefore, when checking the laser diode emission, observe from more than 30 cm away from the objective lens.

### UNLEADED SOLDER

Boards requiring use of unleaded solder are printed with the lead-free mark (LF) indicating the solder contains no lead.

**(Caution:** Some printed circuit boards may not come printed with the lead free mark due to their particular size)

### : LEAD FREE MARK

Unleaded solder has the following characteristics.

- Unleaded solder melts at a temperature about 40 °C higher than ordinary solder.  
Ordinary soldering irons can be used but the iron tip has to be applied to the solder joint for a slightly longer time.  
Soldering irons using a temperature regulator should be set to about 350 °C.  
**Caution:** The printed pattern (copper foil) may peel away if the heated tip is applied for too long, so be careful!
- Strong viscosity  
Unleaded solder is more viscous (sticky, less prone to flow) than ordinary solder so use caution not to let solder bridges occur such as on IC pins, etc.
- Usable with ordinary solder  
It is best to use only unleaded solder but unleaded solder may also be added to ordinary solder.

### NOTE OF REPLACING THE IC102 ON THE DMB19 BOARD

IC102 on the DMB19 board cannot exchange with single. When this part is damaged, exchange the entire mounted board.

### RELEASING THE DISC TRAY LOCK

The disc tray lock function for the antitheft of an demonstration disc in the store is equipped.

#### Releasing Procedure:

1. Press [I/⏻ STANDBY] button to turn the power on.
2. Press the [CD] button to select CD function.
3. While pressing the [■] button, press the [▲ OPEN/CLOSE] button for more 5 seconds).
4. The message “UNLOCKED” is displayed and the disc tray is unlocked.

**Note:** When “LOCKED” is displayed, the slot lock is not released by turning power on/off with the [I/⏻ STANDBY] button.

### MODEL IDENTIFICATION – Back Panel –

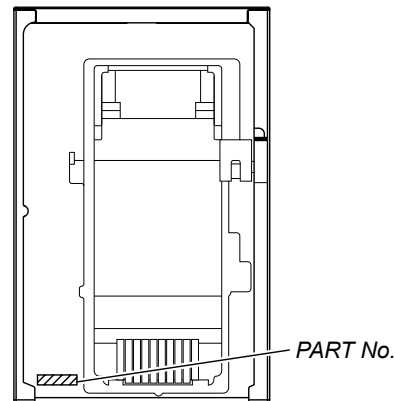

Model	Part No.
HCD-GTR33: E2, E51	4-164-386-0□
HCD-GTR33: AR	4-164-386-1□
HCD-GTR33: MX	4-164-386-2□
HCD-GTR33: E4	4-164-386-4□
HCD-GTR55: E2, E51	4-170-620-0□
HCD-GTR55: AR	4-170-620-1□
HCD-GTR55: MX	4-170-620-2□
HCD-GTR55: E4	4-170-620-4□
HCD-GTR77: E2, E51	4-170-621-0□
HCD-GTR77: AR	4-170-621-1□
HCD-GTR77: MX	4-170-621-2□
HCD-GTR77: E4	4-170-621-4□

- Abbreviation  
AR : Argentina model  
E2 : 120V AC area in E model  
E4 : African model  
E51 : Chilean and Peruvian models  
MX : Mexican model

## HOW TO OPEN THE TRAY WHEN POWER SWITCH TURN OFF

- Step:** 1) Work after removing the case (side-R and side-L) referring to “2.2. CASE(SIDE-L/R)” on disassembly (page 5).  
 2) Work after removing the top case referring to “2-3. TOP CASE” on disassembly (page 6).

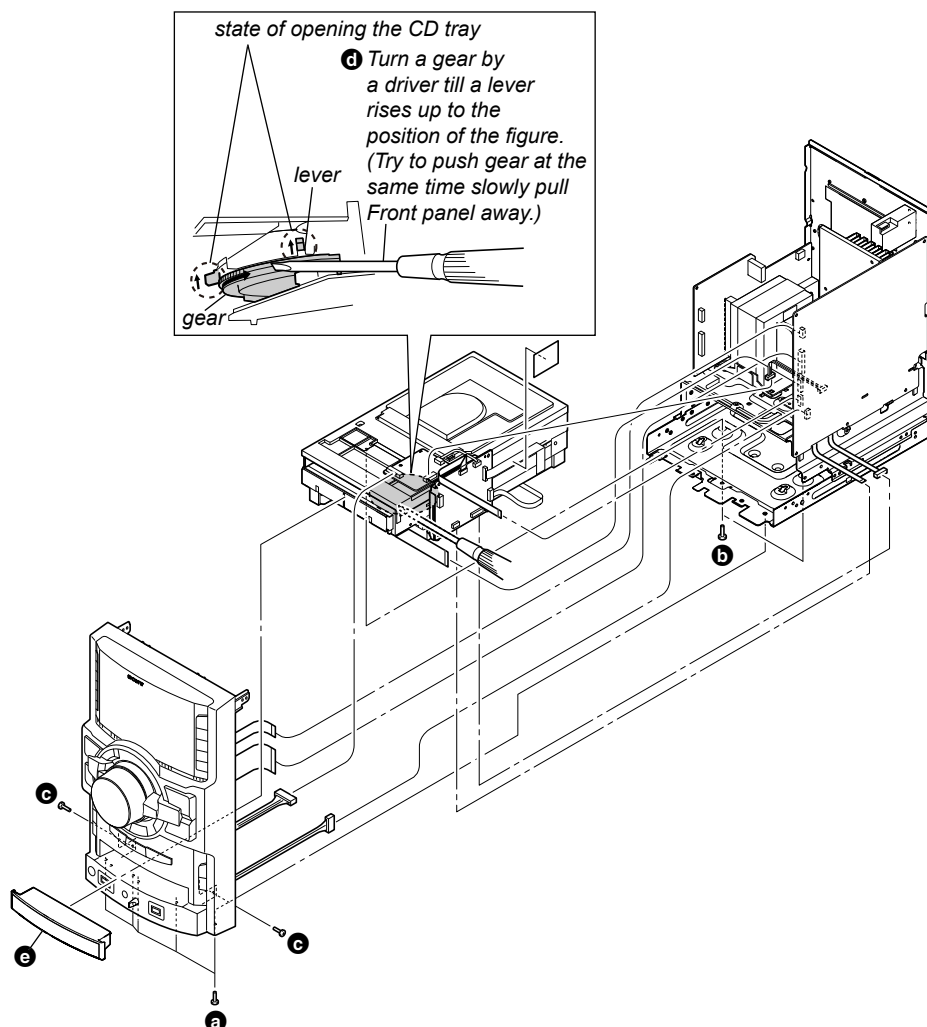

## HOW TO DISTINGUISH TAPE MECHANISM DECK

Two kinds of tape mechanism decks installed by this set exist.

Please do the repair exchange after confirming which tape mechanism deck set of the repair according to how to distinguish the figure below.

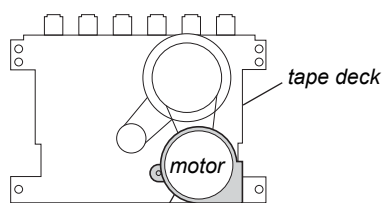

Mold part: CS-21SC-900TP

Tape Deck Name	Tape Deck Part No.	Belt Part No.
CS-21SC-900TP	1-797-575-11	2-688-621-01 BELT (R/F)
		2-688-622-01 BELT (MAIN)

## SECTION 2 DISASSEMBLY

- This set can be disassembled in the order shown below.

### 2-1. DISASSEMBLY FLOW

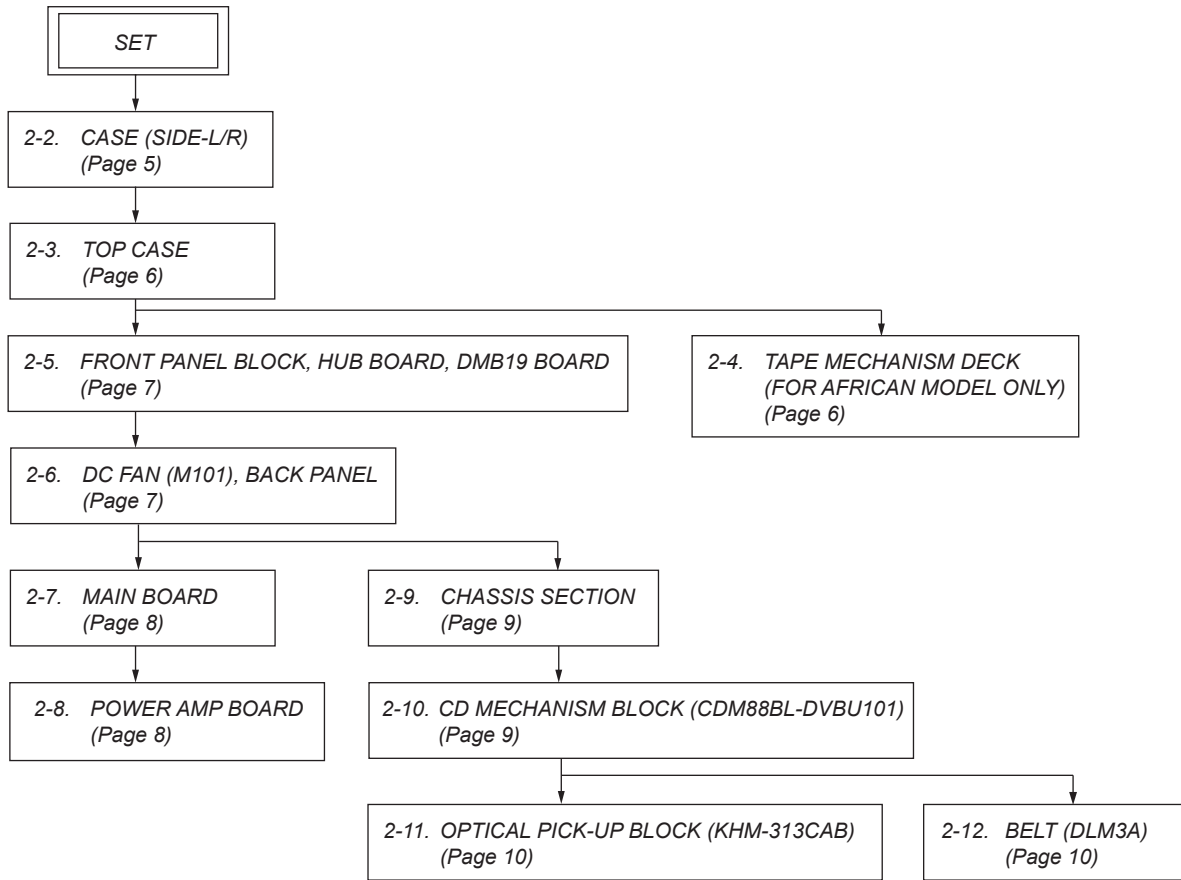

**Note:** Follow the disassembly procedure in the numerical order given.

### 2-2. CASE (SIDE-L/R)

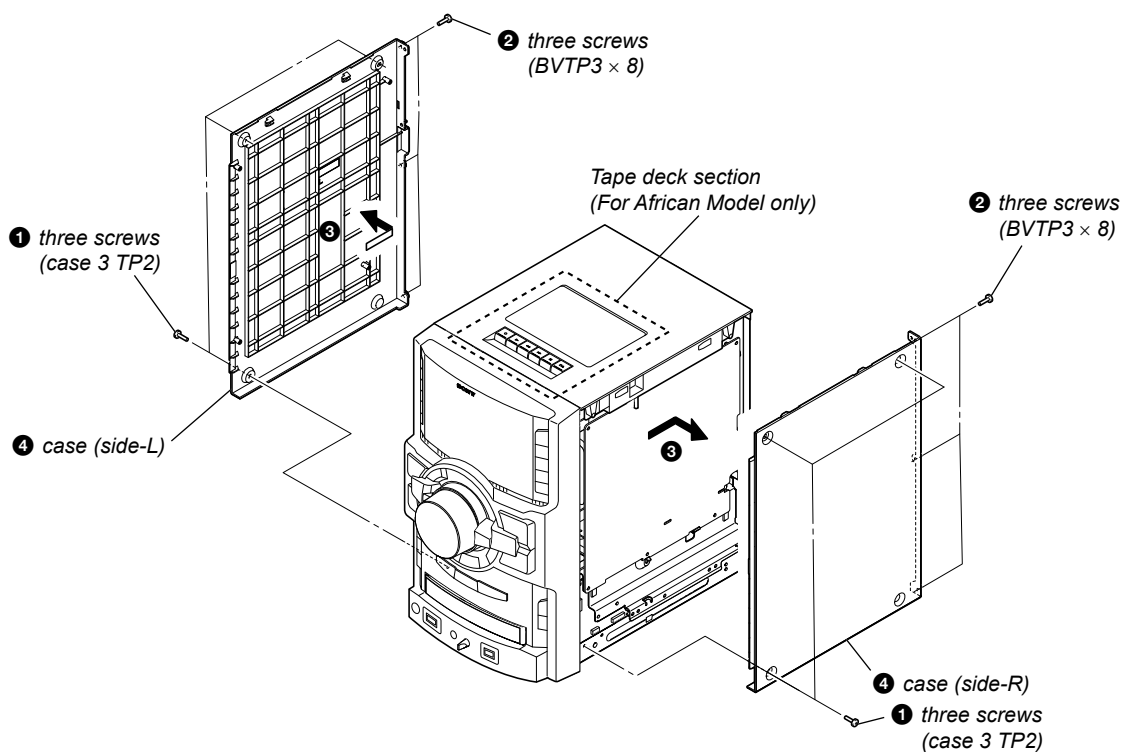

2-3. TOP CASE

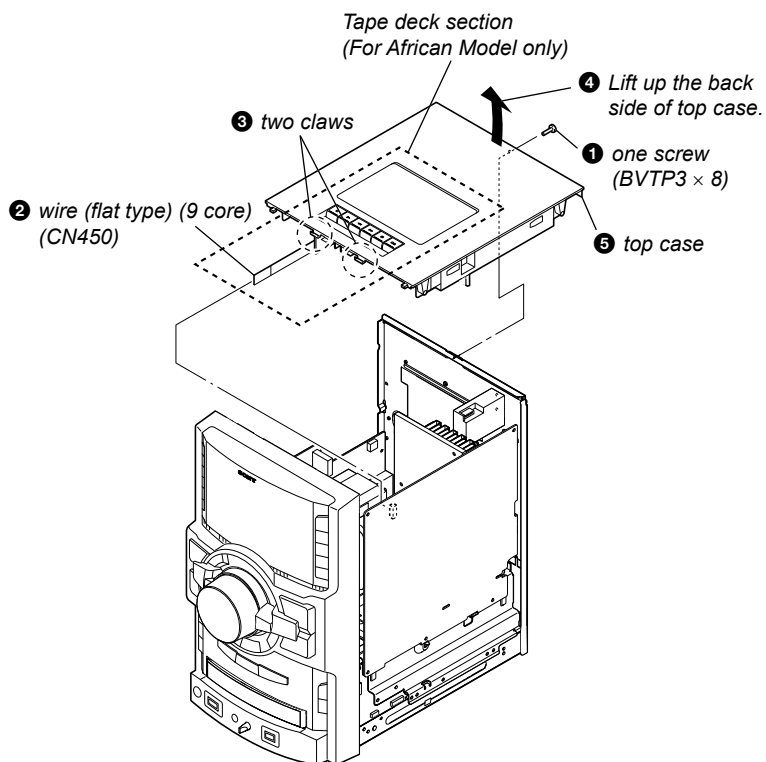

2-4. TAPE MECHANISM DECK (For African model only)

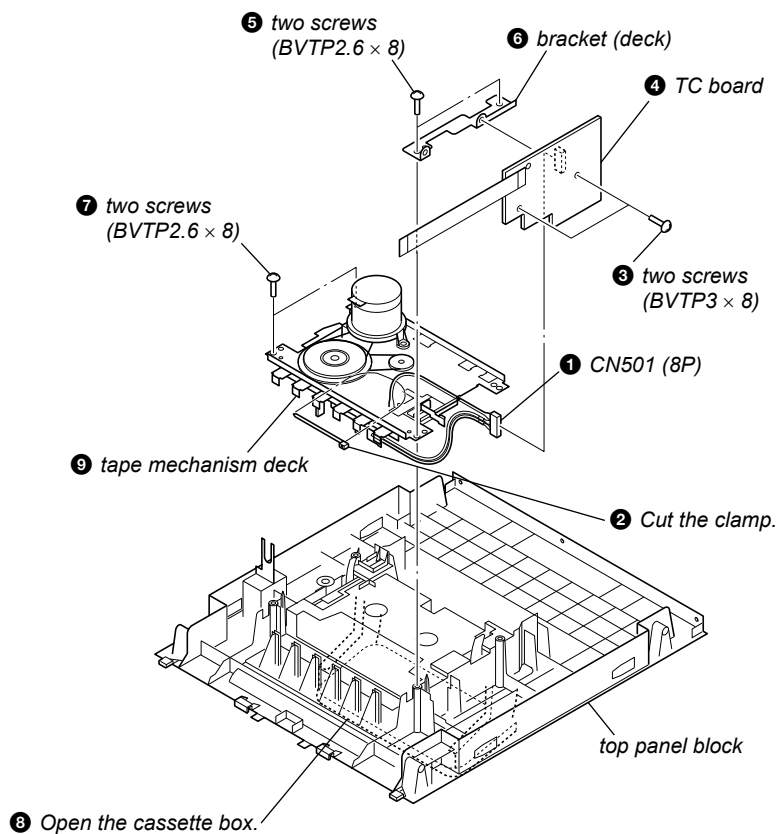



2-5. FRONT PANEL BLOCK, HUB BOARD, DMB19 BOARD

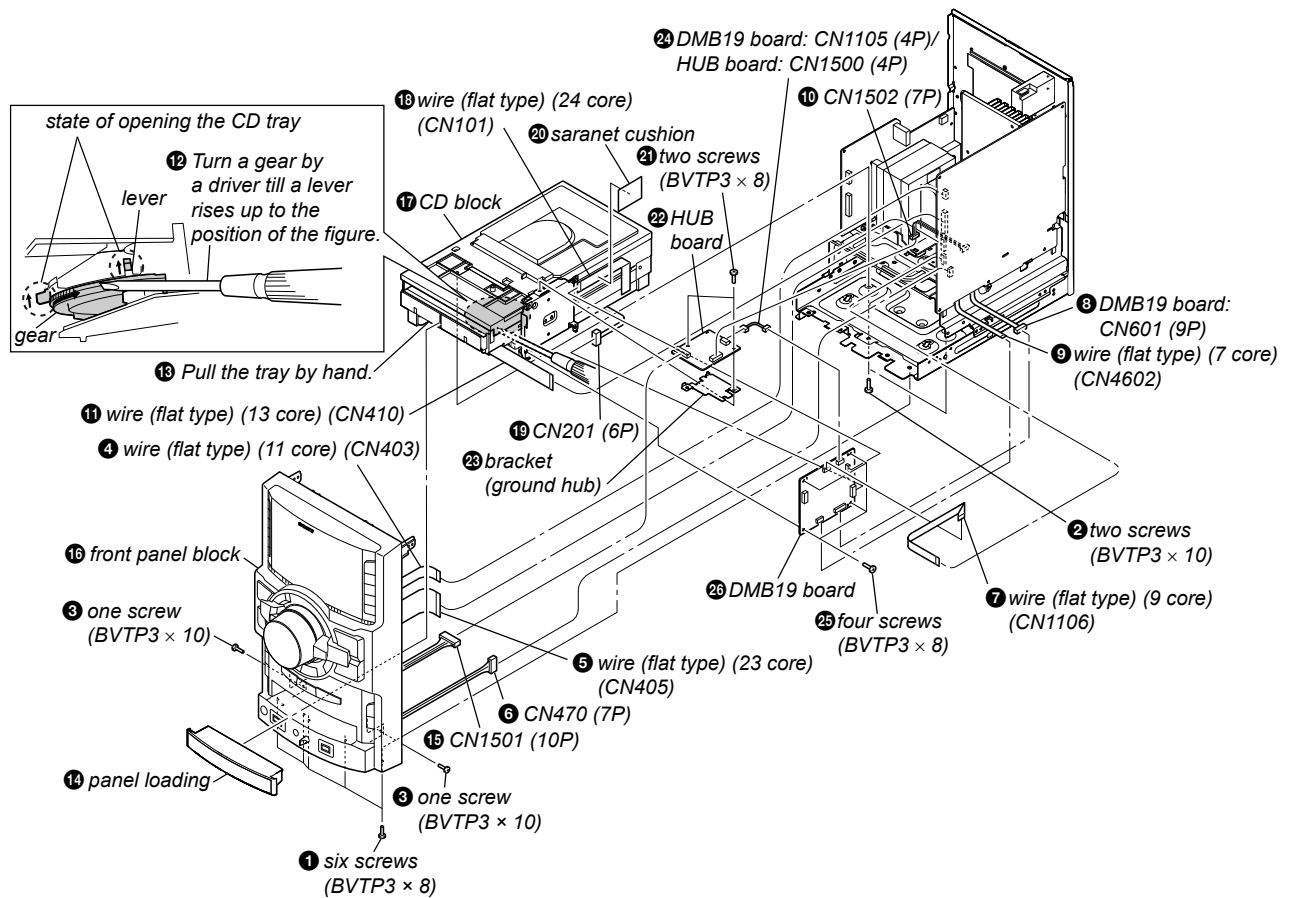

2-6. DC FAN (M101), BACK PANEL

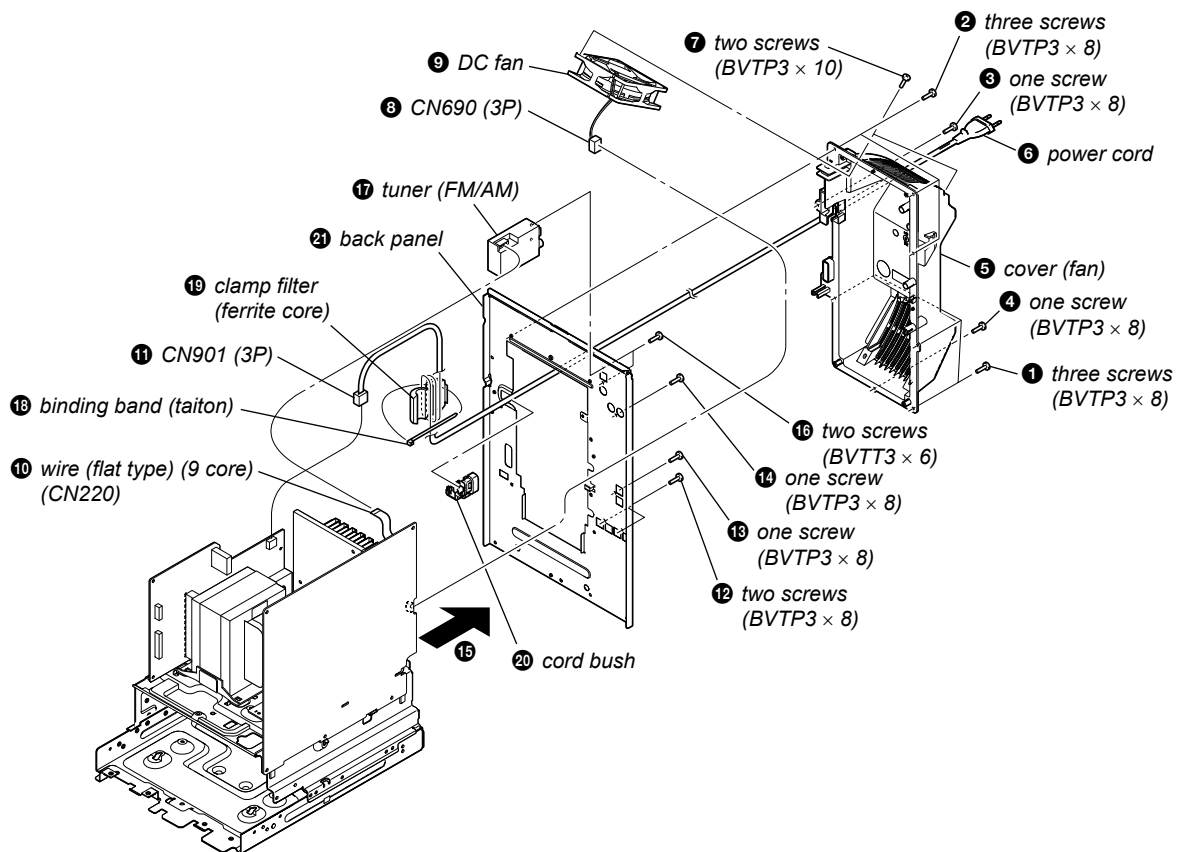

## 2-7. MAIN BOARD

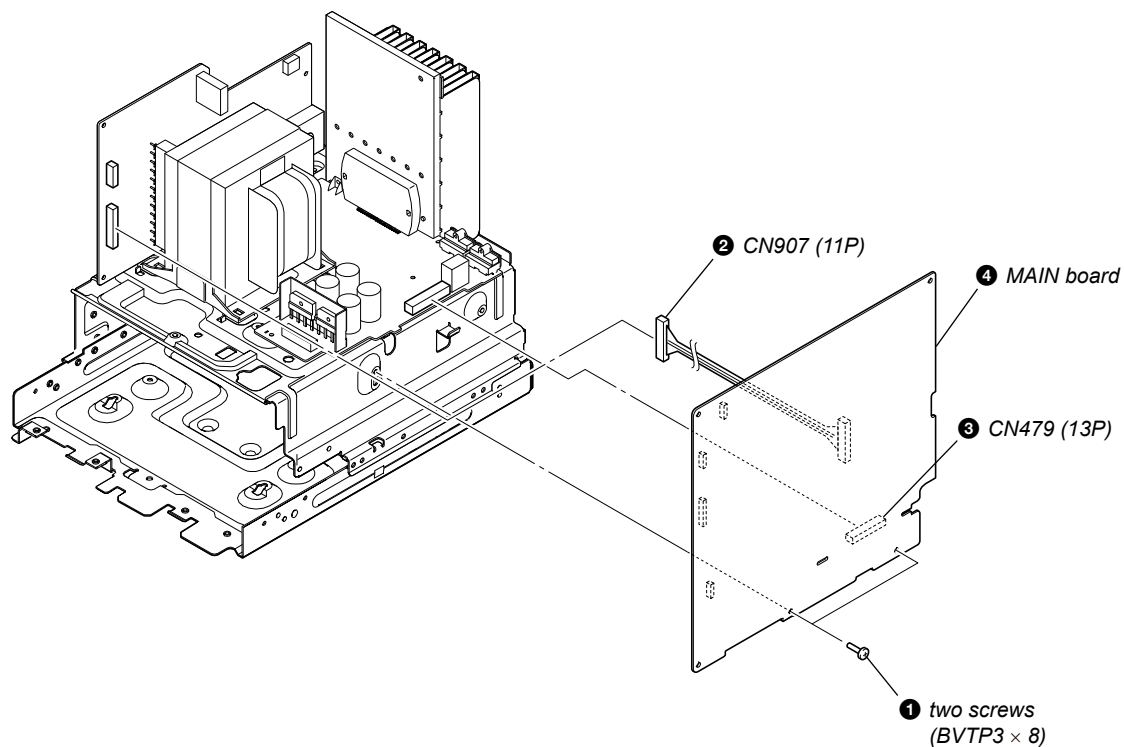

## 2-8. POWER BOARD

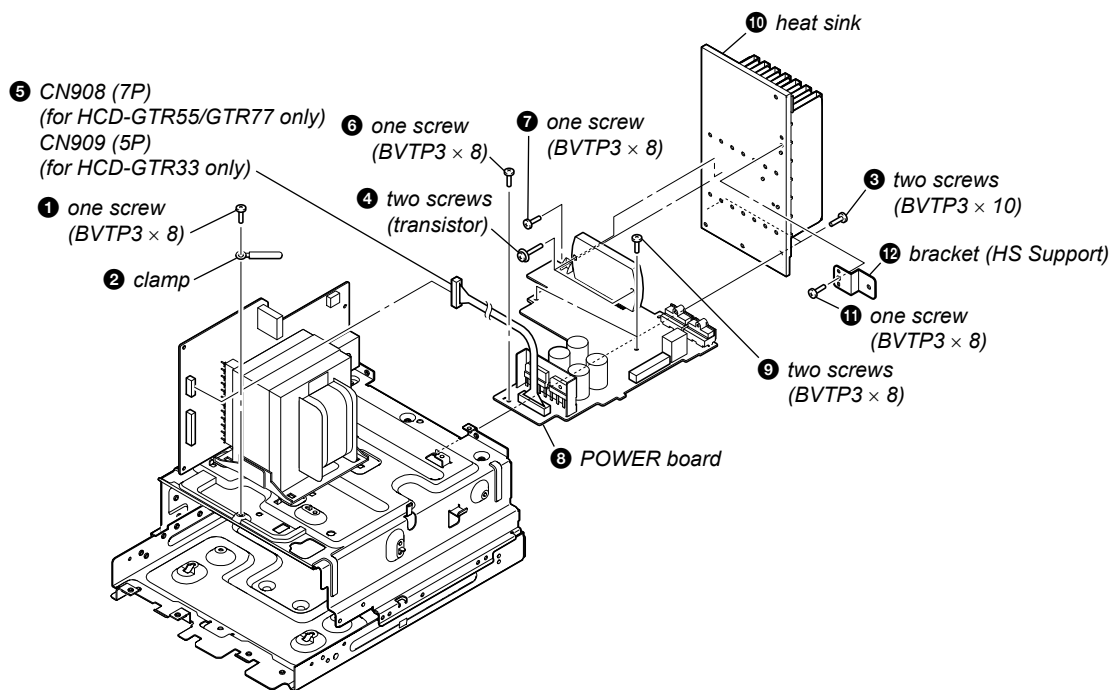



2-9. CHASSIS SECTION

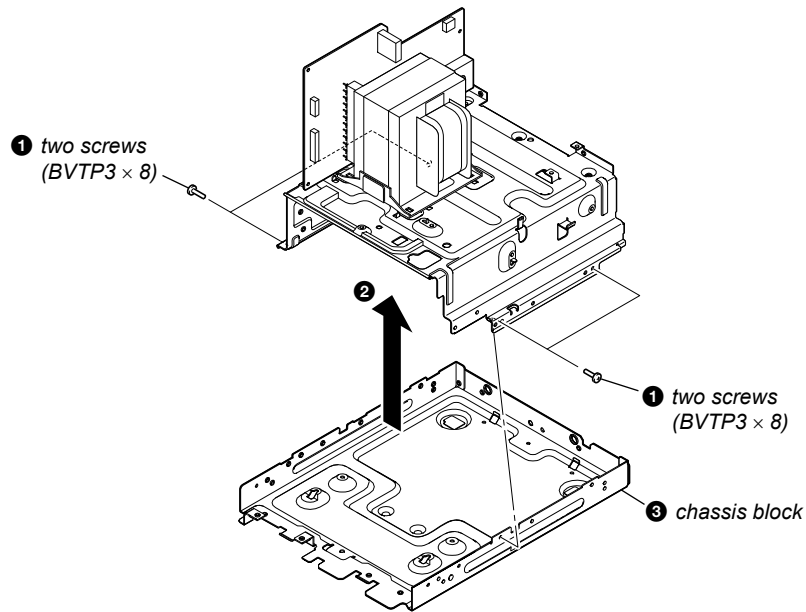

2-10. CD MECHANISM BLOCK (CDM88BL-DVBU101)

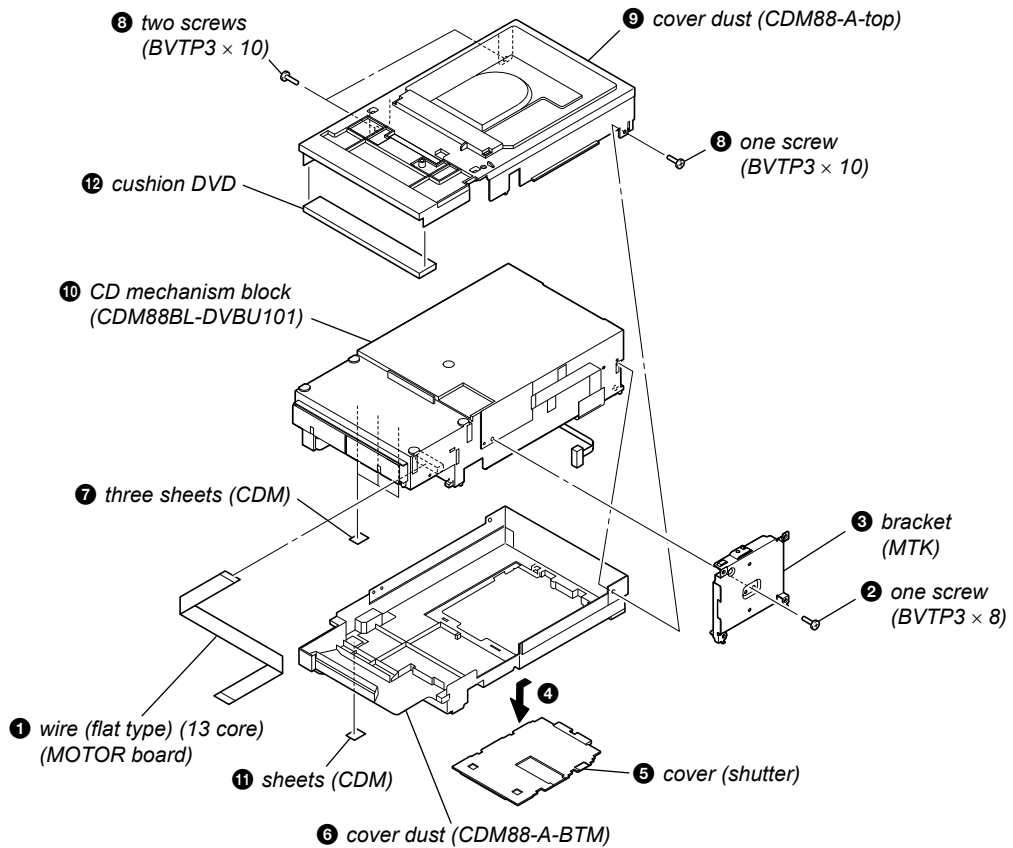

2-11. OPTICAL PICK-UP BLOCK (KHM-313CAB)

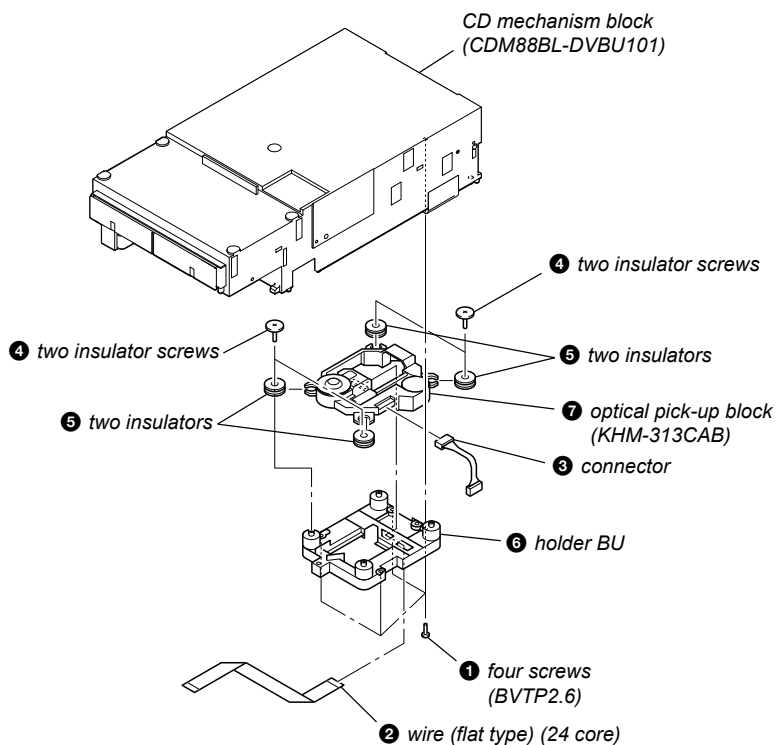

2-12. BELT (DLM3A)

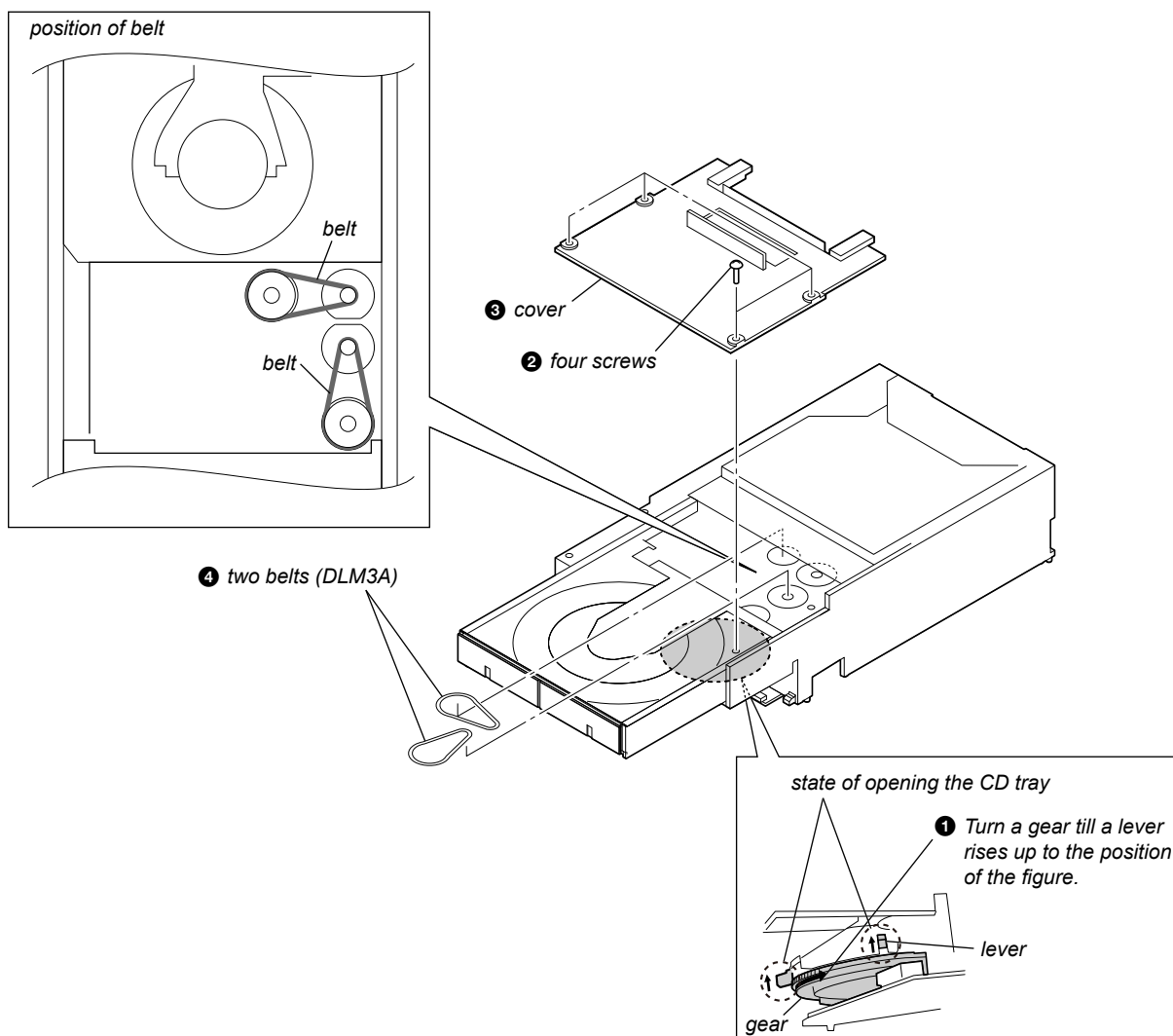

## SECTION 3 TEST MODE

### PANEL TEST MODE

This mode is used to check the fluorescent indicator tube, LEDs, keys, [MASTER VOLUME] jog, [OPERATION DIAL] jog, model, destination and software version.

#### Procedure:

1. Press [■] button, [METER MODE] button and [DISC SKIP/EX-CHANGE] button simultaneously.
2. All LEDs and segments in fluorescent indicator tube are lighted up.
3. When you want to enter to the software version display mode, press [DISC 1] button. The model information appears on the fluorescent indicator tube.
  - “GVX 1S” is shown for MHC-GTR33.
  - “GVX 3S” is shown for MHC-GTR55.
  - “GVX 4S” is shown for MHC-GTR77.

Press [DISC 1] button again to view the destination information.
4. During the destination information display, press [DISC 1] button. Each time [DISC 1] button is pressed, the fluorescent indicator tube shows the version of each category software in the following sequence: SC, MTK (DMB Board firmware version), GC, SYS, CD, CDMA, CDMB, ST, TC TA, TM, MTR (METER) and return back to model information display.
5. When [DISC 3] button is pressed while the version numbers are being displayed except model and destination, the date of the software creation appears. When [DISC 3] button is pressed again, the display returns to the software version display. When [DISC 1] button is pressed while the date of the software creation is being displayed, the date of the software creation is displayed in the same order of software version display.
6. Press [DISC 2] button, the key check mode is activated.
7. In the key check mode, the fluorescent indicator tube displays “K 0 V0”.  
Each time a button is pressed, “K” value increases. However, once a button has been pressed, it is no longer taken into account.  
“V” value increases in the manner of 0,1, 2, 3 ... if [MASTER VOLUME] knob is turned clockwise, or it decreases in the manner of 0, 9, 8,7 ... if [MASTER VOLUME] knob is turned counterclockwise.
8. When [DISC SKIP/EX-CHANGE] button is pressed after all LEDs and segments in fluorescent indicator tube light up, alternate segments in fluorescent indicator tube and LEDs would light up. If you press [DISC SKIP/EX-CHANGE] button again, another half of alternate segments in fluorescent indicator tube and LEDs would light up. Pressing [DISC SKIP/EX-CHANGE] button again would cause all segments in fluorescent indicator tube and LEDs light up.
9. To release from this mode, press three buttons in the same manner as step 1, or disconnect the power cord.

### COMMON TEST MODE

This mode is used to check operations of the Amplifier section.

#### Procedure:

##### To enter Common Test Mode

1. Press [■] button, [METER MODE] button and [OPEN/CLOSE] button simultaneously.
2. The CD ring indicators flash on the fluorescent indicator tube. The function is changed to AUDIO and the volume is changed to VOLUME MIN.

##### Check of Amplifier

1. Press [EQ BAND/SURROUND] button repeatedly until a message “GEQ MAX” appears on the fluorescent indicator tube. GEQ increases to its maximum.

2. Press [EQ BAND/SURROUND] button repeatedly until a message “GEQ MIN” appears on the fluorescent indicator tube. GEQ decreases to its minimum.
3. Press [EQ BAND/SURROUND] button repeatedly until a message “GEQ FLAT” appears on the fluorescent indicator tube. GEQ is set to flat.
4. When the [MASTER VOLUME] knob is turned clockwise even slightly, the sound volume increases to its maximum and a message “VOLUME MAX” appears on the fluorescent indicator tube.
5. When the [MASTER VOLUME] knob is turned counterclockwise even slightly, the sound volume decreases to its minimum and a message “VOLUME MIN” appears on the fluorescent indicator tube.

#### To release from Common Test mode

1. To release from this mode, press [I/⏻ STANDBY] button.
2. The cold reset is enforced at the same time.

### COLD RESET

The cold reset clears all data including preset data stored in the EEPROM to initial conditions. Execute this mode when returning the set to the customer.

#### Procedure:

1. Press [I/⏻ STANDBY] button to turn on the system.
2. Press [■] button, [ENTER] button, and [I/⏻ STANDBY] button simultaneously.
3. “COLD RESET” appears on the fluorescent indicator tube. After that, the fluorescent indicator tube becomes blank for a while, and the system is reset.

### VACS ON/OFF

This mode is used to switch ON and OFF the VACS (Variable Attenuation Control System).

#### Procedure:

1. Press [I/⏻ STANDBY] button to turn on the system.
2. Press [■] button, [RETURN], and [DISPLAY] button simultaneously. The message “VACS OFF” or “VACS ON” appears on the fluorescent indicator tube.

### TUNER STEP CHANGE

The step interval of AM channels can be toggled between 9 kHz and 10 kHz.

#### Procedure:

1. Press [I/⏻ STANDBY] button to turn on the system.
2. Press [TUNER/BAND] button repeatedly to select the “AM”.
3. Press [I/⏻ STANDBY] button to turn off the system.
4. Press [ENTER] button and [I/⏻ STANDBY] button simultaneously. The system turns on automatically. The message “AM 9K STEP” or “AM 10K STEP” appears on the fluorescent indicator tube and thus the channel step is changed.

### CD SHIP MODE (WITH MEMORY CLEAR)

This mode moves the optical pick-up to the position durable to vibration and clears all data including preset data stored in the EEPROM to initial conditions during the next AC-In. Use this mode when returning the set to the customer after repair.

#### Procedure:

1. Press [I/⏻ STANDBY] button to turn on the system.
2. Select CD function.
3. Press [■] button, [OPEN/CLOSE] button and [I/⏻ STANDBY] button simultaneously. The system turns off automatically.
4. After the “STANDBY” blinking display finishes, a message “MECHA LOCK” is displayed on the fluorescent indicator tube and the CD ship mode is set.

## CD SHIP MODE (WITHOUT MEMORY CLEAR)

This mode moves the optical pick-up to the position durable to vibration. Use this mode when returning the set to the customer after repair.

### Procedure:

1. Press [I/⏻ STANDBY] button to turn on the system.
2. Select CD function.
3. Press [DISC SKIP/EX-CHANGE] button and [I/⏻ STANDBY] button simultaneously. The system turns off automatically.
4. After the "STANDBY" blinking display finishes, a message "MECHA LOCK" is displayed on the fluorescent indicator tube and the CD ship mode is set.

## CD TRAY LOCK MODE

This mode let you lock the disc tray. When this mode is activated, the disc tray will not open when [OPEN/CLOSE] button or [DISC SKIP/EX-CHANGE] button is pressed. The message "LOCKED" will be displayed on the fluorescent indicator tube. This mode only applied when there is disc(s) on the tray.

### Procedure:

1. Press [I/⏻ STANDBY] button to turn on the system.
2. Select CD function.
3. Press [■] button and [OPEN/CLOSE] button simultaneously and hold down until "LOCKED" or "UNLOCKED" displayed on the fluorescent indicator tube (around 5 seconds).

## FACTORY PRESET

This mode is use to load all the factory use preset frequencies into FM 1-FM 20 and AM 1-AM 10. Originally, frequency of FM 1-FM 20 and AM 1-AM10 are set to the minimum frequency.

### Procedure:

1. Press [I/⏻ STANDBY] button to turn on the system.
2. Press [EQ BAND/SURROUND] button, [■] button, and [DISC 1] button simultaneously and the message "FACTORY" appears on the fluorescent indicator tube. The function is changed to TUNER automatically.

## VACS DISPLAY

This mode is used to check the VACS level.

### Procedure:

1. Press [I/⏻ STANDBY] button to turn on the system.
2. Press [ERASE] button, [■] button and [ENTER] button simultaneously.
3. The fluorescent indicator tube displays "V0 AP0".  
"V" represents Conventional VACS (Triggered by signal level)  
"AP" represents AP VACS (Abuse Protection Variable Attenuation Control System)  
• To release from VACS display mode  
To release from this mode, do the step (2) again.

## METER SWITCH TOUCH COUNT DISPLAY

This mode is used to display the total count of meter pointer touch initial switch and max switch.

### Procedure:

1. Press [I/⏻ STANDBY] button to turn on the system.
2. Press [■] button, [ENTER] button and [DISPLAY] button simultaneously.
3. The fluorescent indicator tube displays "IxxxxMyyyy".  
"I" represents the Initial Switch touch.  
"xxxx" represents the total count of Initial Switch touch. (Maximum Value of "xxxx" = 65535)  
"M" represents the Max Switch touch.  
"yyyy" represents the total count of Max Switch touch. (Maximum Value of "yyyy" = 65535)  
• To release from Meter Switch Touch Count Display Mode.  
To release from this mode, do the step (2) again.  
The fluorescent indicator tube displays "MODE OUT".

## METER TEST MODE

This mode is used to check the meter device.

### Procedure:

1. Press [I/⏻ STANDBY] button to turn on the system.
2. Press [■] button, [ENTER] button and [METER MODE] button simultaneously.
3. Meter Backlight LEDs, Meter Pointer LEDs, Power Illuminator LEDs and fluorescent indicator tube are lighted up.
4. When you want to perform count total step from Initial Switch to Max Switch operation mode, press [▶▶ / ▶▶▶ / TUNING + ] button. The meter pointer will move from Initial Switch to Max Switch and finally move back to the middle position. The total step count information appears on the fluorescent indicator tube. "xxx STP yy" is shown.  
"xxx" represents the total step.  
(Value of "xxx" should between 430 steps to 470 steps)  
"yy" represents the status of total step count.  
(If total step between 430 steps to 470 steps, "yy" is OK, Else "yy" is NG)
5. When you want to perform count total step from Max Switch to Initial Switch operation mode, press [◀◀ / ◀◀◀ / TUNING - ] button. The meter pointer will move from Max Switch to Initial Switch and finally move back to the middle position. The total step count information appears on the fluorescent indicator tube. "xxx STP yy" is shown.  
"xxx" represents the total step.  
(Value of "xxx" should between 430 steps to 470 steps)  
"yy" represents the status of total step count.  
(If total step between 430 steps to 470 steps, "yy" is OK, else "yy" is NG)  
• To release from Meter Test Mode.  
To release from this mode, do the step (2) again.  
The fluorescent indicator tube displays "TST MODE OUT".

## CDM AGING MODE

This mode is used to display the total count of all disc playing.

### Procedure:

1. Press [I/⏻ STANDBY] button to turn on the system.
2. Select CD function and All DISC play mode
3. Put discs on all trays and close the tray.
4. Press [GROOVE] button, [■] button and [RETURN] button simultaneously.
5. The fluorescent indicator tube displays Aging Display "AG xxxx/yyyy".  
"xxxx" represents the error counter  
(Maximum Value of "xxxx" = 9999)  
"yyyy" represents the cycle counter  
(Maximum Value of "yyyy" = 9999)
6. Press [◀◀ / ◀◀◀ / TUNING - ] or [▶▶ / ▶▶▶ / TUNING + ] to search for Aging History Error Display  
The fluorescent indicator tube displays "Mx E1E2E3E4".  
x: error history number  
E1: Loading sequence JCP high  
E2: Loading sequence JCP low  
E3: Loading operation JCP  
E4: Cam position operation JCP
7. Press [RETURN] to Aging Display  
• To release from CDM Aging Mode.  
To release from this mode, press [I/⏻ STANDBY] button or perform COLD RESET operation.

## SECTION 4 MECHANICAL ADJUSTMENTS

**(For African model only)**

### PRECAUTION

1. Clean the following parts with a denatured-alcohol-moistened-swab :
 

record/playback head	pinch roller
erase head	rubber belts
capstan	idlers
2. Demagnetize the record/playback head with a head demagnetizer. (Do not bring the head magnetizer close to the erase head.)
3. Do not use a magnetized screwdriver for the adjustments.
4. After the adjustments, apply suitable locking compound to the parts adjusted.
5. The adjustments should be performed with the rated power supply voltage unless otherwise noted.

### • Torque Measurement

Mode	Torque Meter	Meter Reading
FWD	CQ-102AS	2.0 – 8.0 mN • m (20 to 80 g • cm) (0.28 – 1.12 oz • inch)
FWD Back Tension	CQ-102C	0.15 – 0.6 mN • m (1.5 to 6 g • cm) (0.021 – 0.083 oz • inch)
FF	CQ-201AS	5 – 17.7 mN • m (50 to 177 g • cm) (0.7 – 2.48 oz • inch)
REV	CQ-201B	5 – 17.7 mN • m (50 to 177 g • cm) (0.7 – 2.48 oz • inch)

### • Tape Tension Measurement

Mode	Tension Meter	Meter Reading
FWD	CQ-403A	more than 80 g (more than 2.82 oz)

## SECTION 5 ELECTRICAL CHECK

### TUNER SECTION

#### FM TUNE LEVEL CHECK

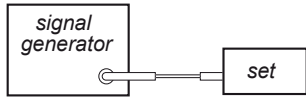

**Procedure:**

1. Turn on the set.
2. Input the following signal from signal generator to FM antenna input directly.

Carrier frequency : A = 87.5 MHz, B = 98 MHz, C = 108 MHz  
 Deviation : 75 kHz  
 Modulation : 1 kHz  
 ANT input : 35 dBu (EMF)

**Note:** Use 75 ohm coaxial cable to connect signal generator and the set.  
 You cannot use video cable for checking.  
 Use signal generator whose output impedance is 75 ohm.

3. Set to FM tuner function and tune A, B and C signals.
4. Confirm "TUNED" is lit on the display for A, B and C signals.

When the selected station signal is received in good condition, "TUNED" is displayed.

### DECK SECTION

0dB = 0.775V

**(For African model only)**

1. Demagnetize the record/playback head with a head demagnetizer.
2. Do not use a magnetized screwdriver for the adjustments.

#### TEST TAPE

Tape	Signal	Used for
P-4-A063	6.3 kHz, -10 dB	Azimuth Adjustment

#### RECORD/PLAYBACK HEAD AZIMUTH ADJUSTMENT

**Procedure:**

1. Mode: Playback

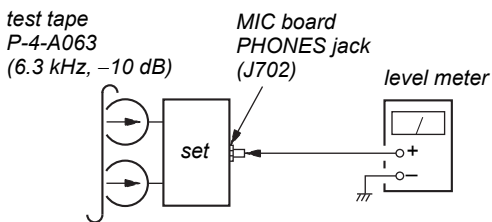

2. Turn the adjustment screw and check output peaks. If the peaks do not match for L-CH and R-CH, turn the adjustment screw so that outputs match within 1dB of peak.

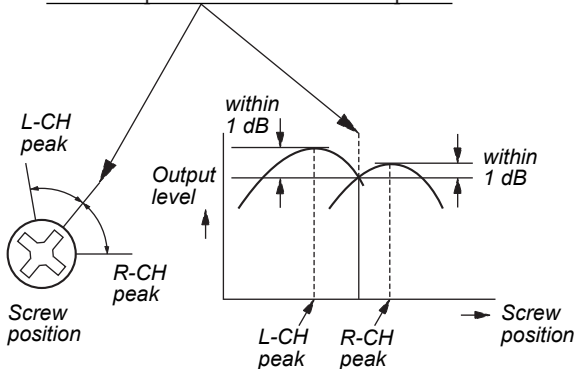

3. Mode: Playback

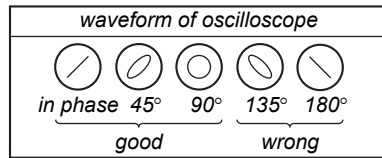
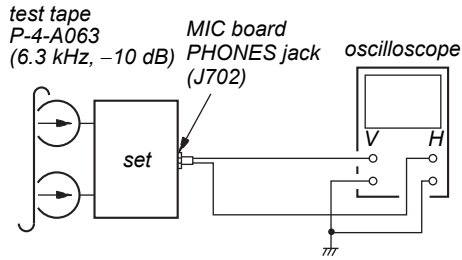

4. After the adjustments, apply suitable locking compound to the parts adjusted.

**Adjustment Location:** Record/Playback/Erase Head

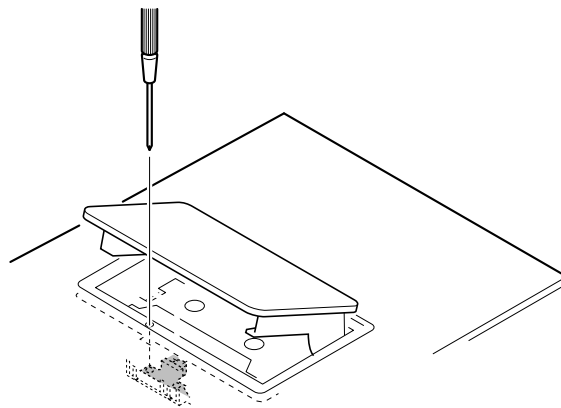



SECTION 6  
DIAGRAMS

6-1. BLOCK DIAGRAM - RF SERVO, USB Section -

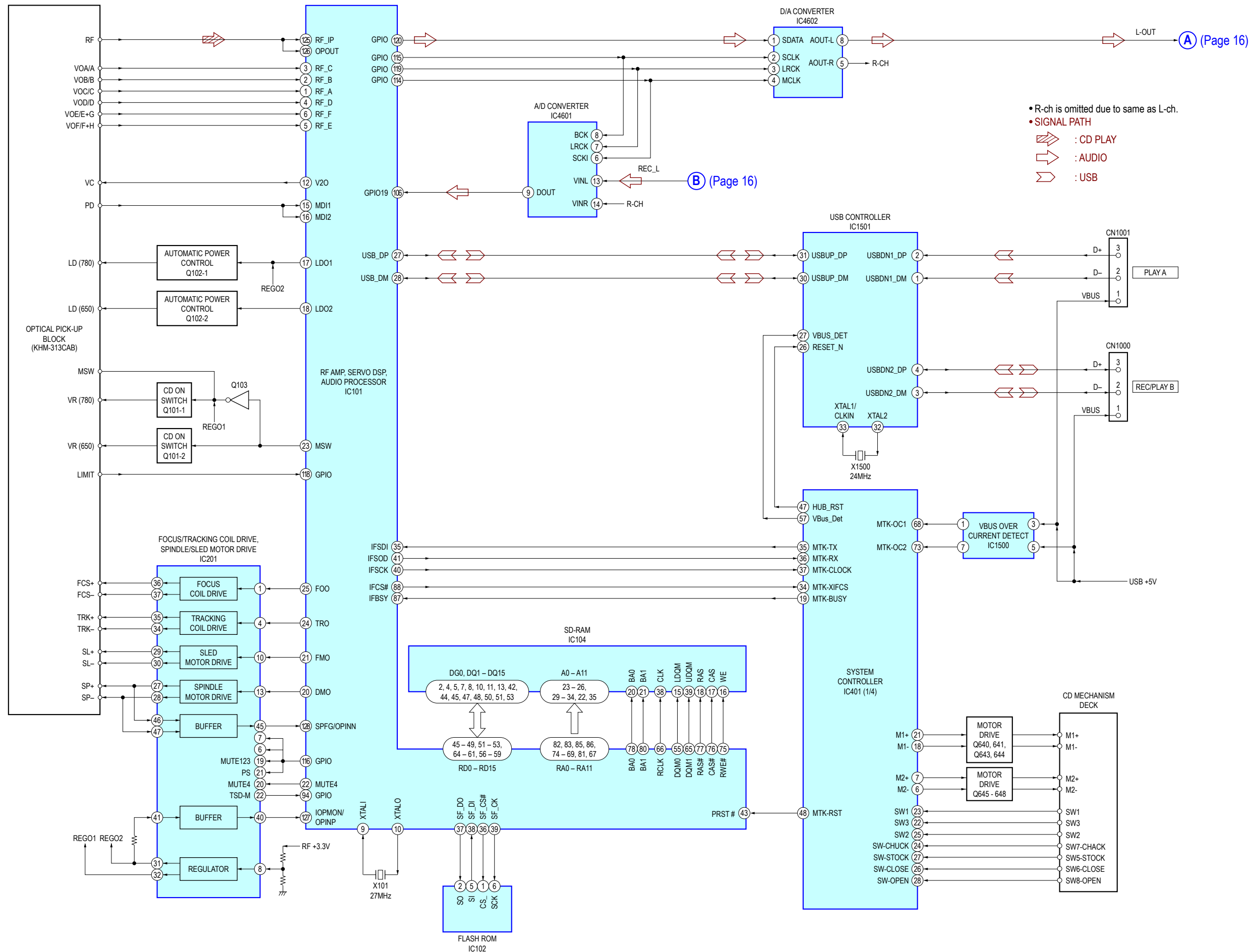

6-2. BLOCK DIAGRAM - MAIN Section -

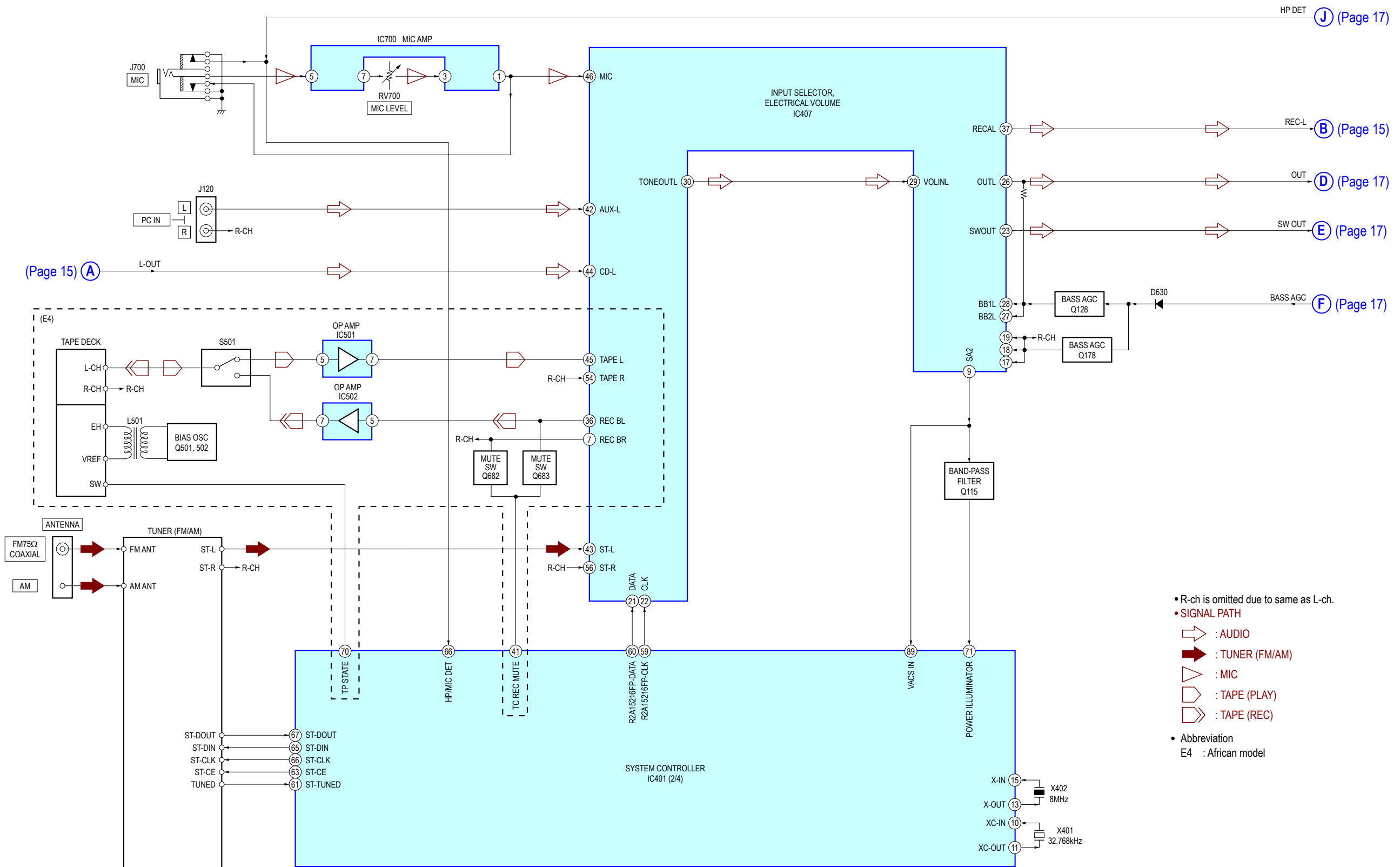

6-3. BLOCK DIAGRAM - AMP Section -

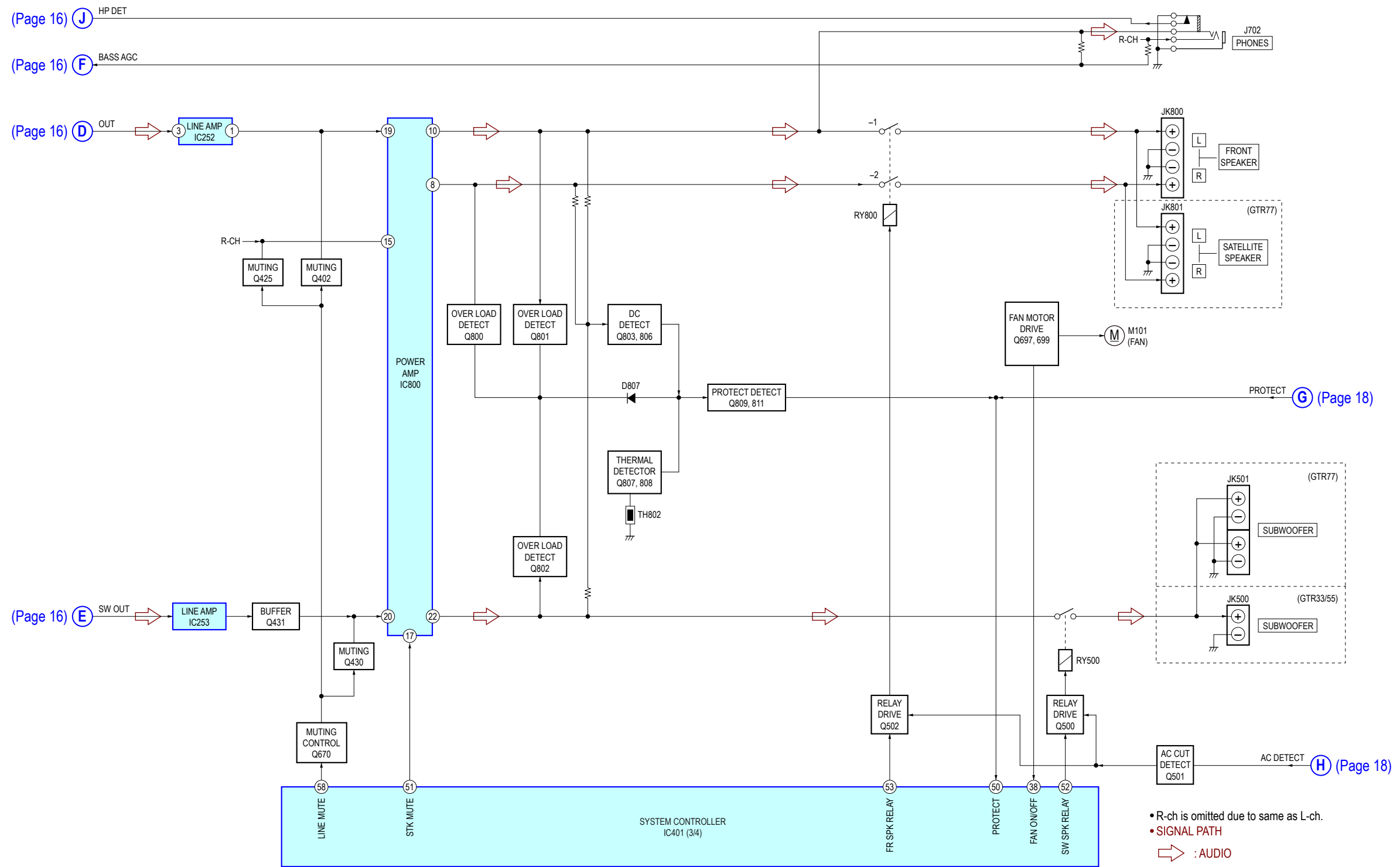

6-4. BLOCK DIAGRAM - PANEL, POWER SUPPLY Section -

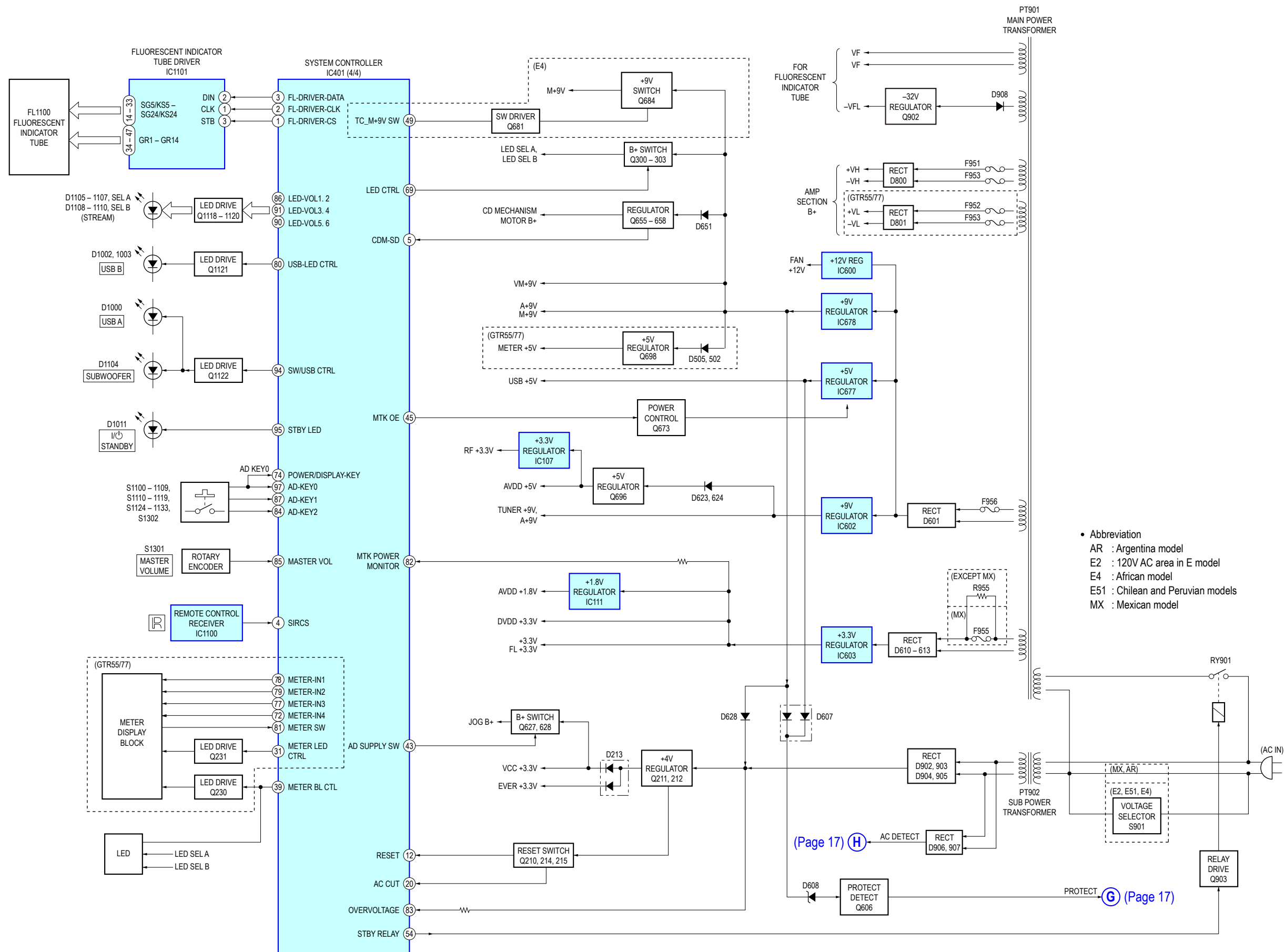

**THIS NOTE IS COMMON FOR PRINTED WIRING BOARDS AND SCHEMATIC DIAGRAMS.**  
**(In addition to this, the necessary note is printed in each block.)**

**For Printed Wiring Boards.**

**Note:**

- : Parts extracted from the component side.
- : Parts extracted from the conductor side.
- △: Internal component.
- : Pattern from the side which enables seeing. (The other layers' patterns are not indicated.)

**Caution:**

Pattern face side: Parts on the pattern face side seen (Conductor Side) from the pattern face are indicated.  
 Parts face side: Parts on the parts face side seen from (Component Side) the parts face are indicated.

**Caution:**

Pattern face side: Parts on the pattern face side seen (SIDE B) from the pattern face are indicated.  
 Parts face side: Parts on the parts face side seen from (SIDE A) the parts face are indicated.

- DMB19 board is multi-layer printed board. However, the patterns of intermediate layers have not been included in diagrams.
- Indication of transistor.

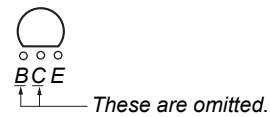
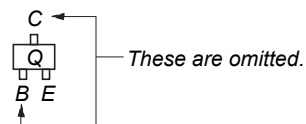

- Abbreviation
- AR : Argentina model
- E2 : 120V AC area in E model
- E4 : African model
- E51 : Chilean and Peruvian models
- MX : Mexican model

**For Schematic Diagrams.**

**Note:**

- All capacitors are in  $\mu\text{F}$  unless otherwise noted. (p: pF) 50 WV or less are not indicated except for electrolytics and tantalums.
- All resistors are in  $\Omega$  and 1/4 W or less unless otherwise specified.
- △: Internal component.
- ⊞: Nonflammable resistor.
- ⊞: Fusible resistor.
- : Panel designation.

**Note:** The components identified by mark △ or dotted line with mark △ are critical for safety. Replace only with part number specified.

- : B+ Line.
- - -: B- Line.
- Voltages and waveforms are dc with respect to ground under no-signal (detuned) conditions.
  - TC Board -
  - no mark : TAPE PLAY
  - ( ) : TAPE REC
  - Other Boards -
  - no mark : TUNER (FM/AM)
  - ( ) : CD PLAY
  - << >> : TAPE PLAY
  - [ ] : TAPE REC
  - < > : USB
  - { } : PC
  - \* : Impossible to measure
- Voltages are taken with VOM (Input impedance 10 M $\Omega$ ). Voltage variations may be noted due to normal production tolerances.
- Waveforms are taken with a oscilloscope. Voltage variations may be noted due to normal production tolerances.
- Circled numbers refer to waveforms.
- Signal path.
  - ⇒ : AUDIO
  - ⇒ : TUNER (FM/AM)
  - ⇒ : TAPE PLAY
  - ⇒ : TAPE REC
  - ⇒ : MIC
  - ⇒ : CD PLAY
  - ⇒ : DIGITAL
  - ⇒ : USB

- Abbreviation
- AR : Argentina model
- E2 : 120V AC area in E model
- E4 : African model
- E51 : Chilean and Peruvian models
- MX : Mexican model

**• Circuit Boards Location**

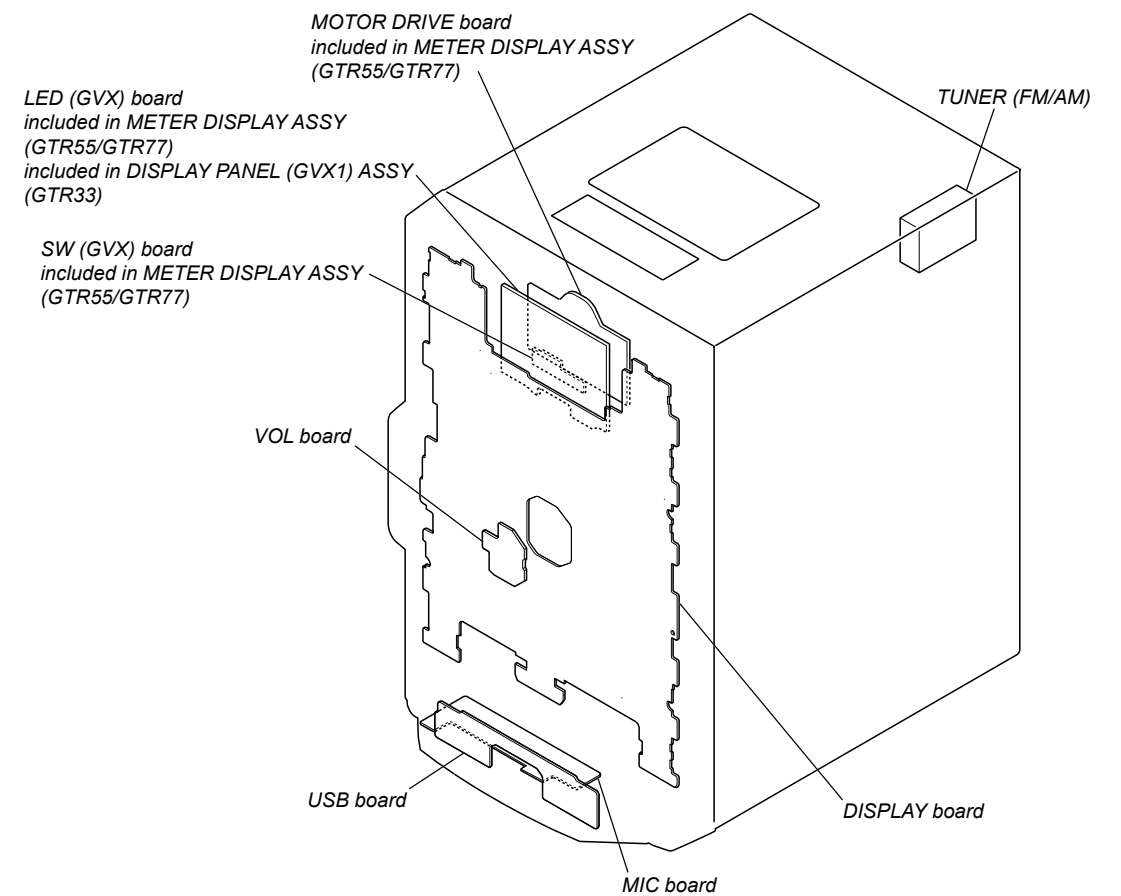
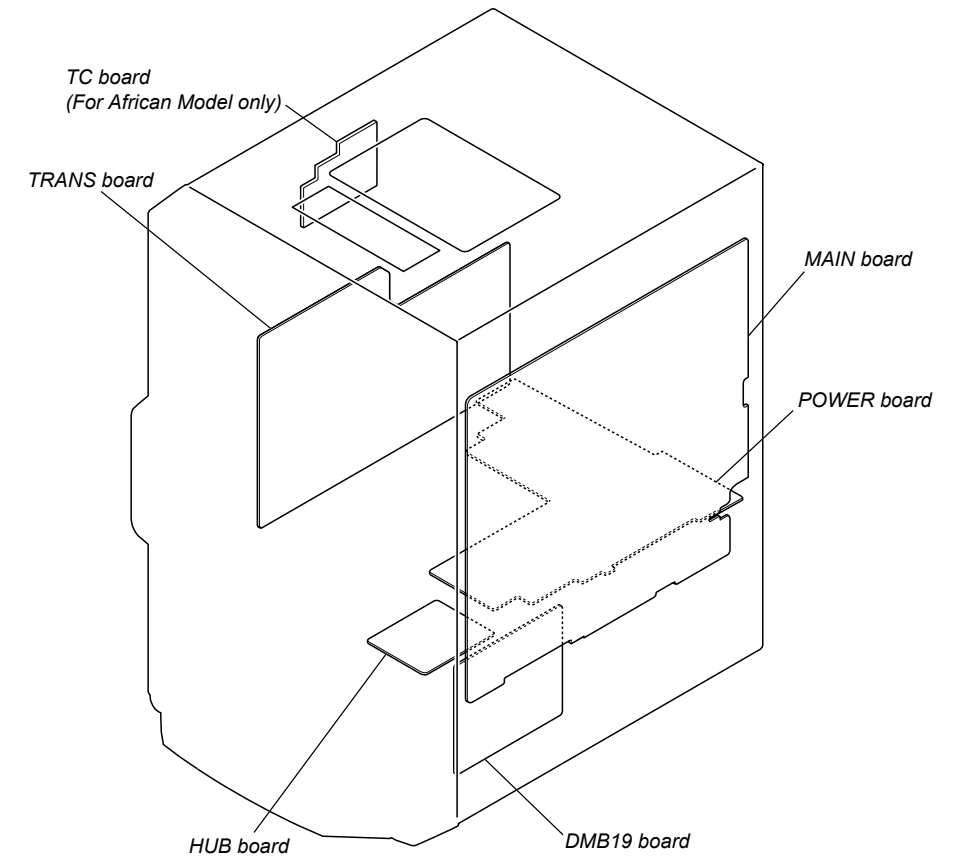

6-5. PRINTED WIRING BOARD - DMB19 Board - • See page 19 for Circuit Boards Location. •  : Uses unleaded solder.

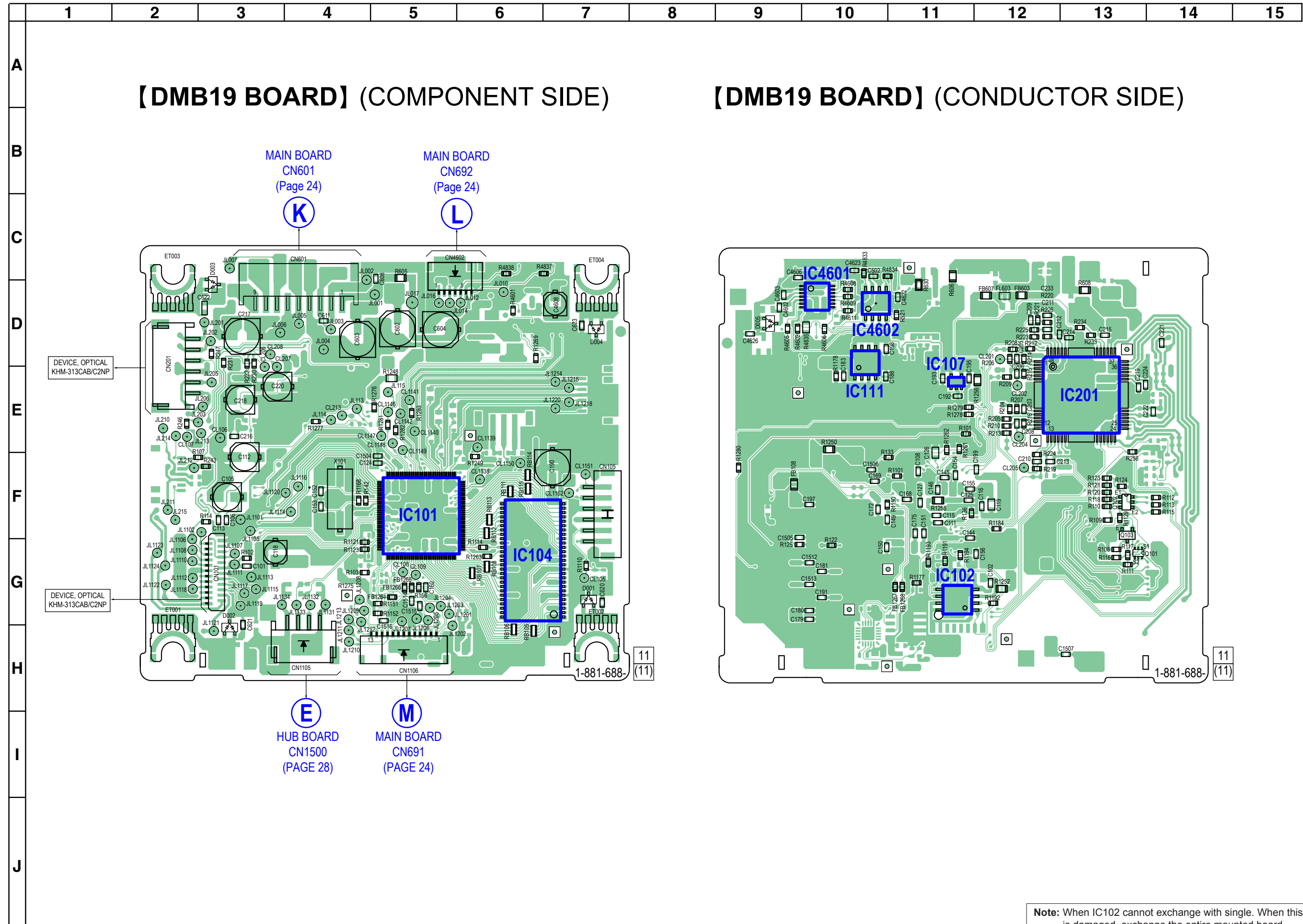

**Note:** When IC102 cannot exchange with single. When this part is damaged, exchange the entire mounted board.



6-6. SCHEMATIC DIAGRAM - DMB19 Board (1/3) - • See page 39 for Waveforms. • See page 40 for IC Block Diagrams. • See page 44 for IC Pin Function Description.

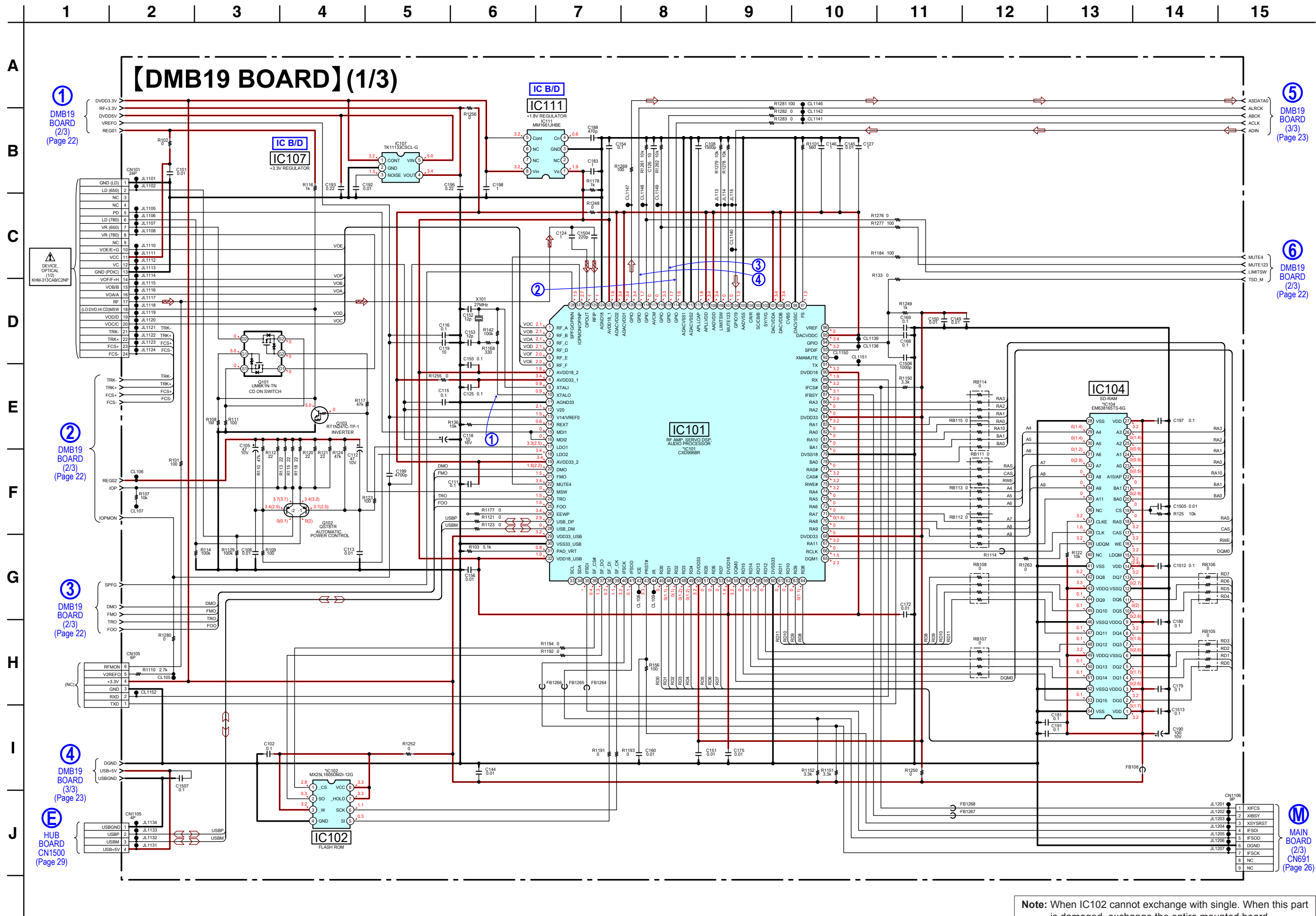

Note: When IC102 cannot exchange with single. When this part is damaged, exchange the entire mounted board.

6-7. SCHEMATIC DIAGRAM - DMB19 Board (2/3) - See page 40 for IC Block Diagrams.

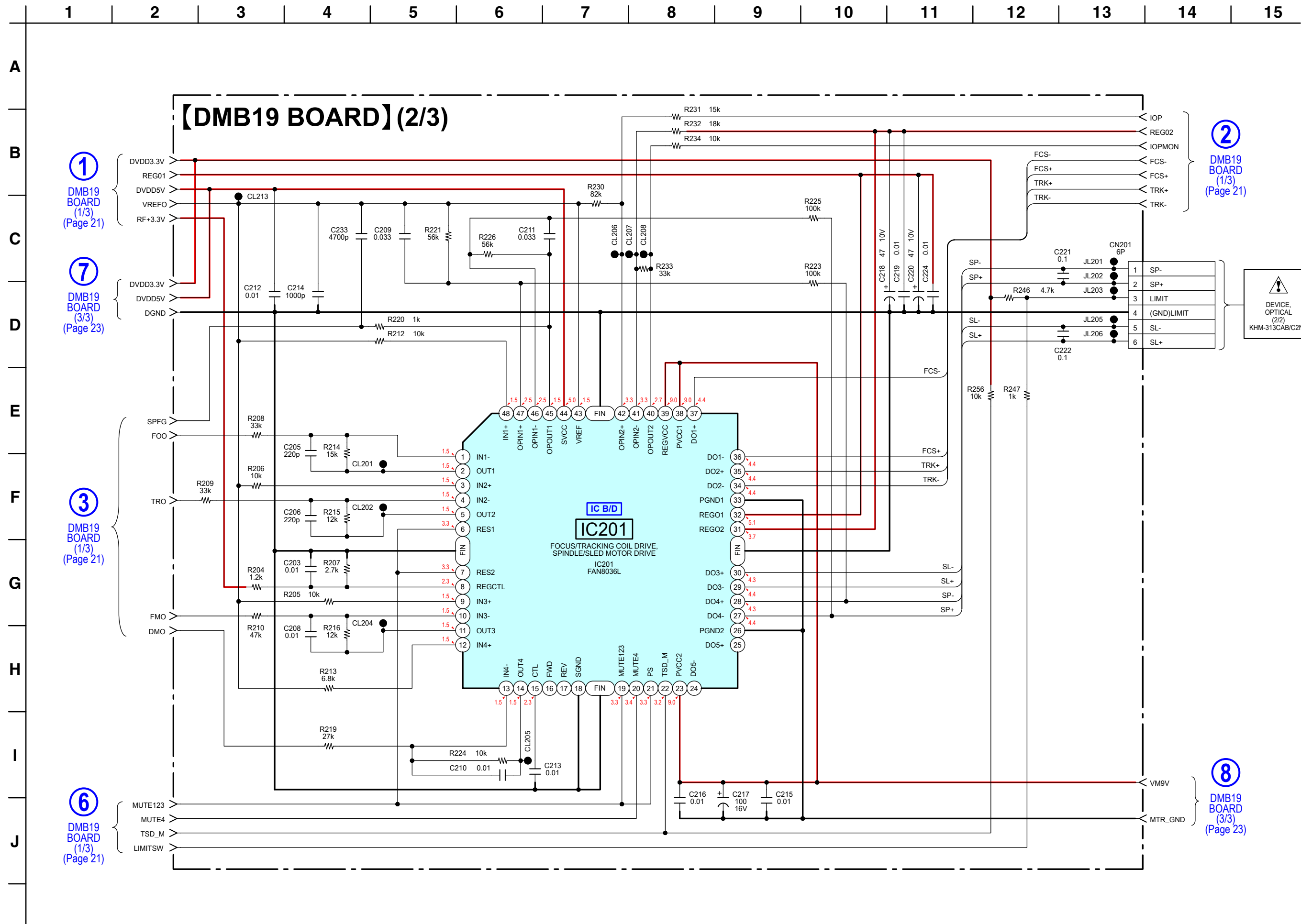

6-8. SCHEMATIC DIAGRAM - DMB19 Board (3/3) - See page 40 for IC Block Diagrams.

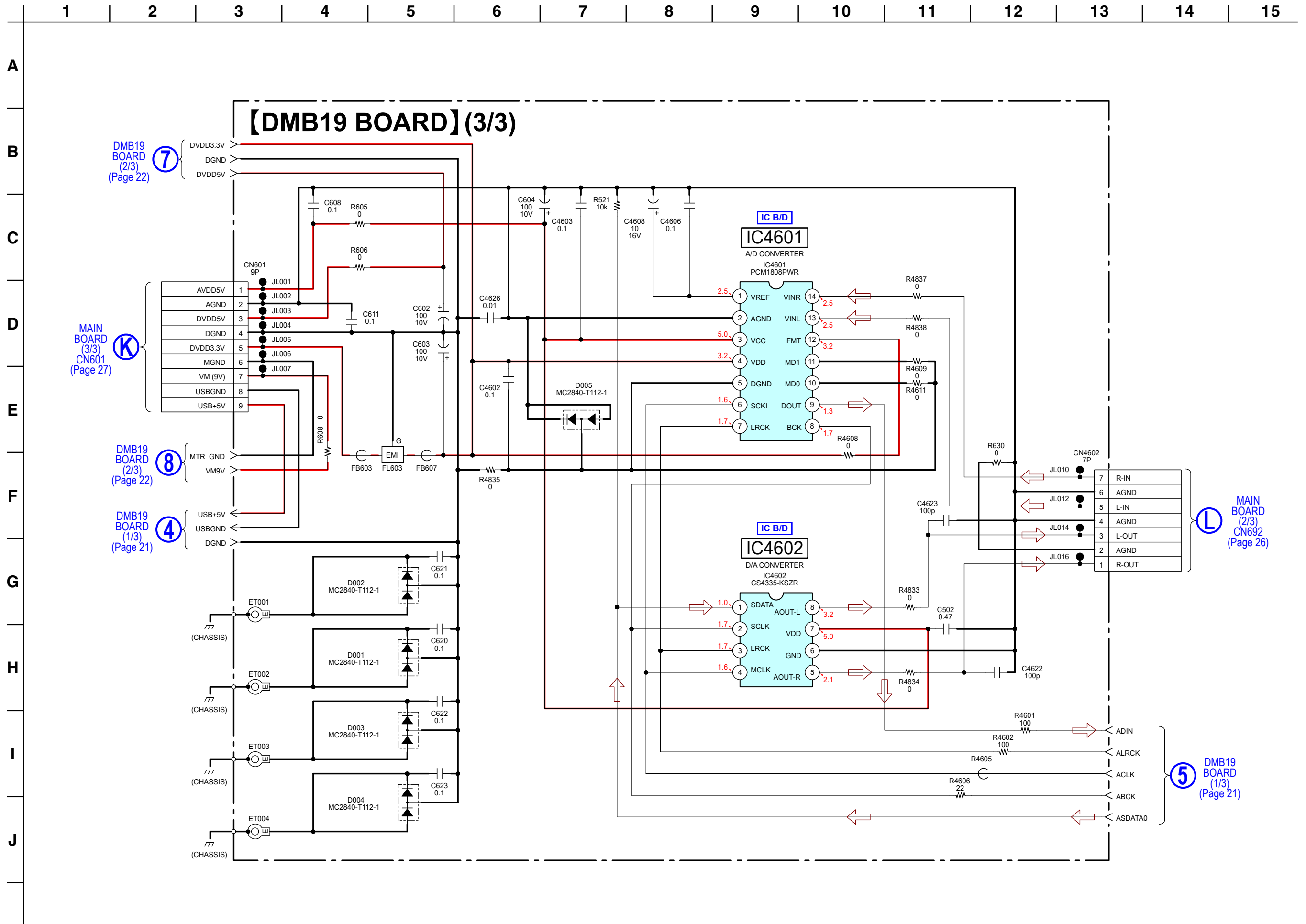

6-9. PRINTED WIRING BOARD - MAIN Board - • See page 19 for Circuit Boards Location. •  : Uses unleaded solder.

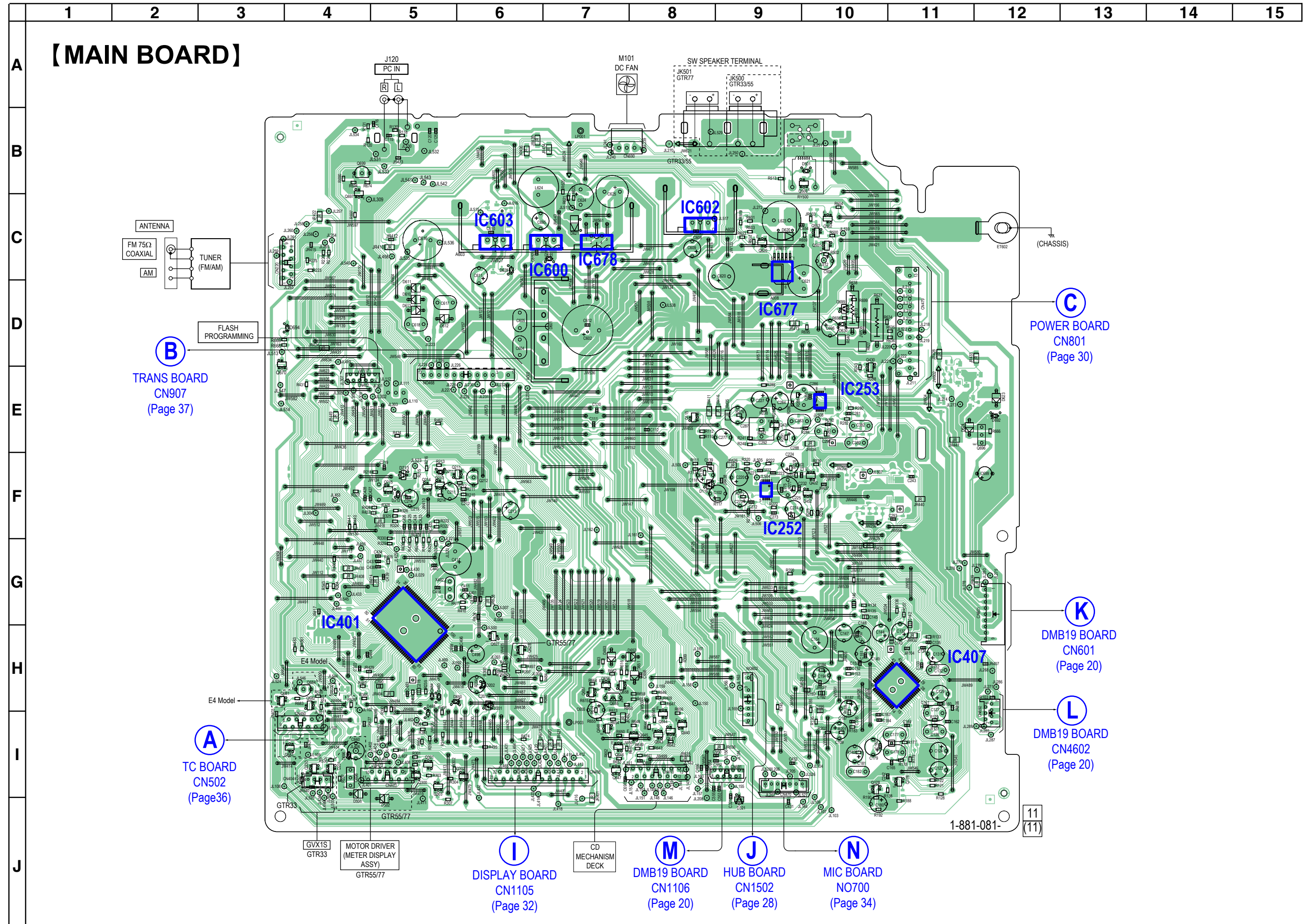



6-10. SCHEMATIC DIAGRAM - MAIN Board (1/3) - See page 39 for Waveforms. See page 40 for IC Pin Function Description.

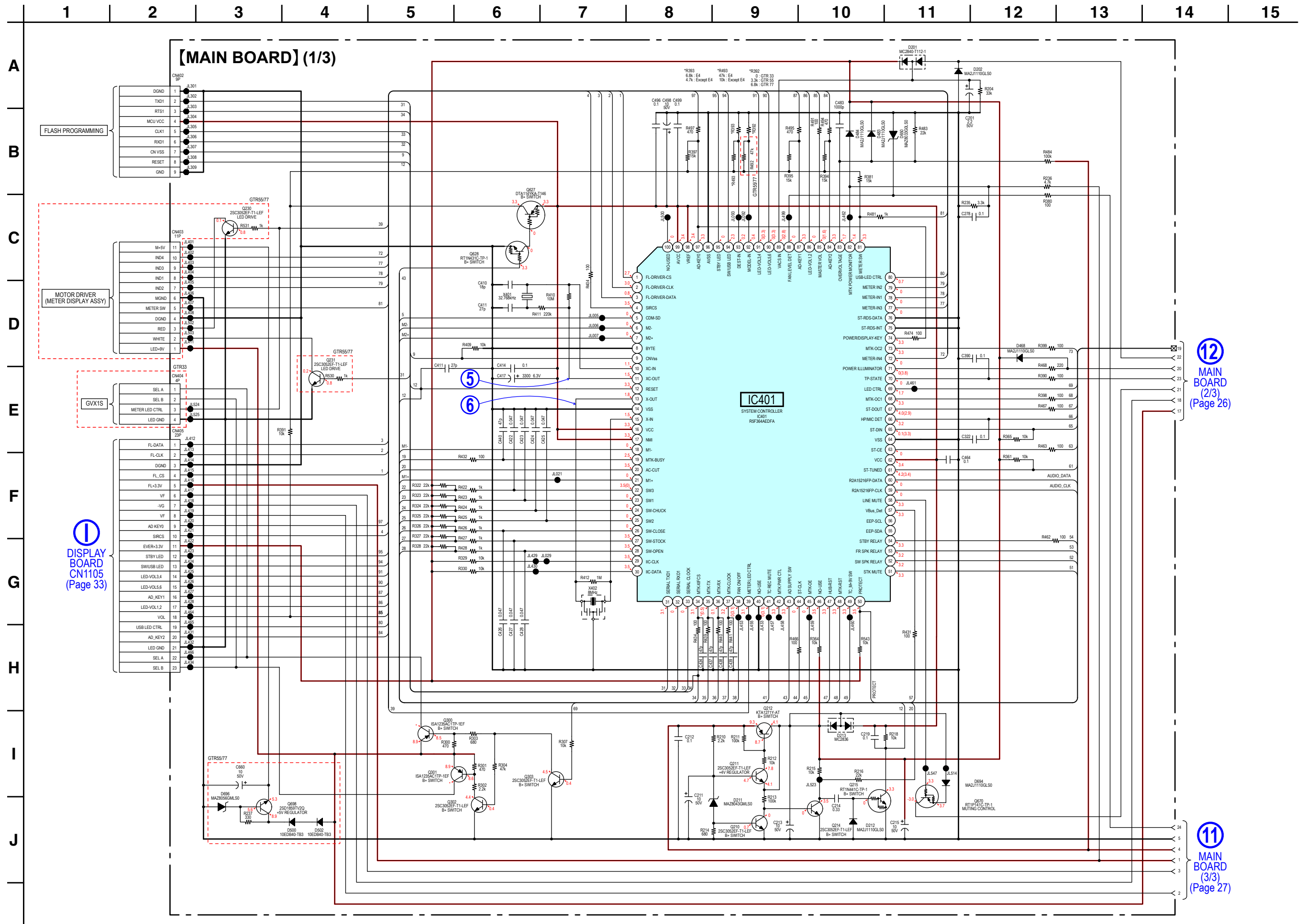

12 MAIN BOARD (2/3) (Page 26)

11 MAIN BOARD (3/3) (Page 27)

1 DISPLAY BOARD CN1105 (Page 33)

6-11. SCHEMATIC DIAGRAM - MAIN Board (2/3) - See page 40 for IC Block Diagrams.

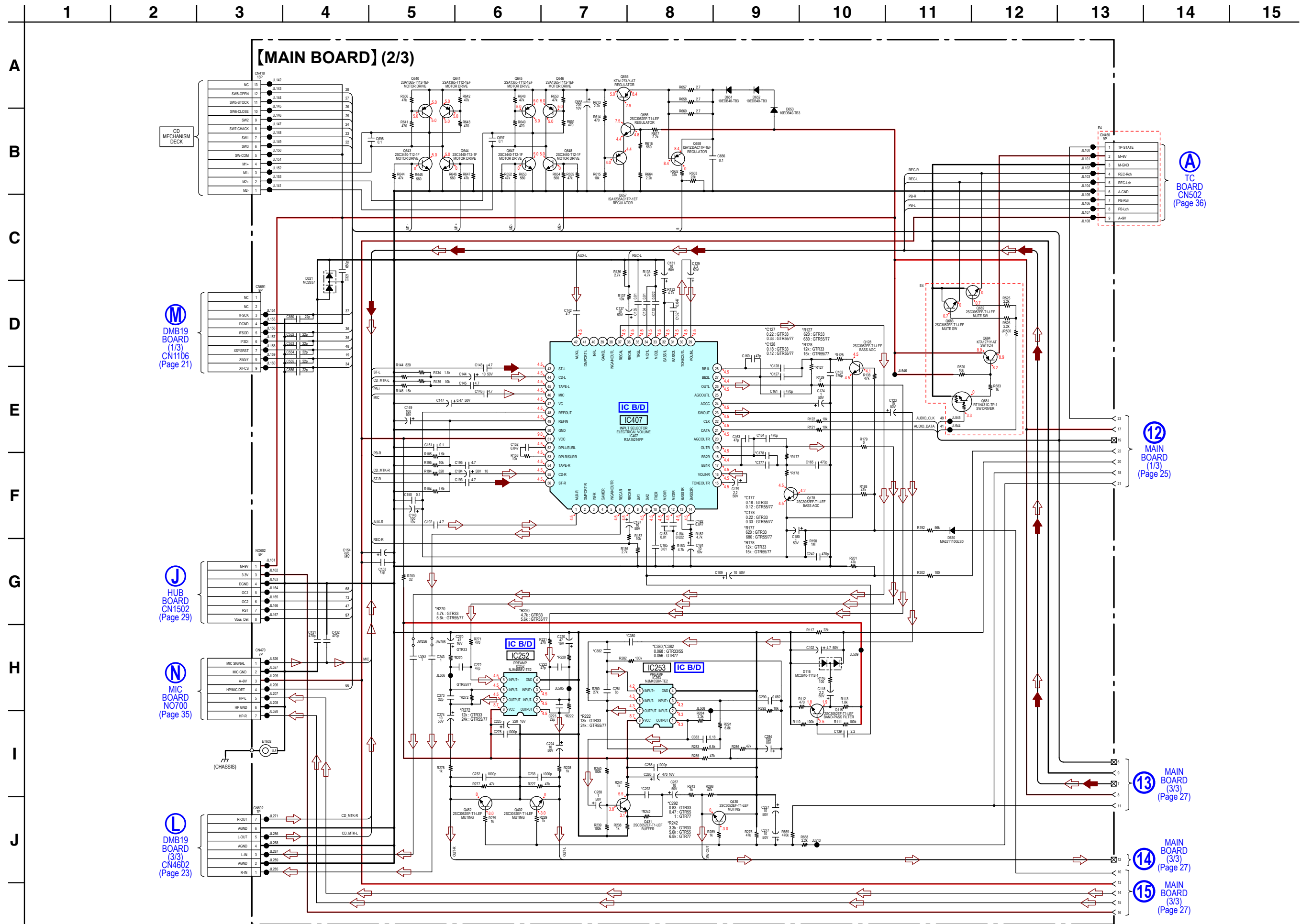



6-12. SCHEMATIC DIAGRAM - MAIN Board (3/3) - See page 40 for IC Block Diagrams.

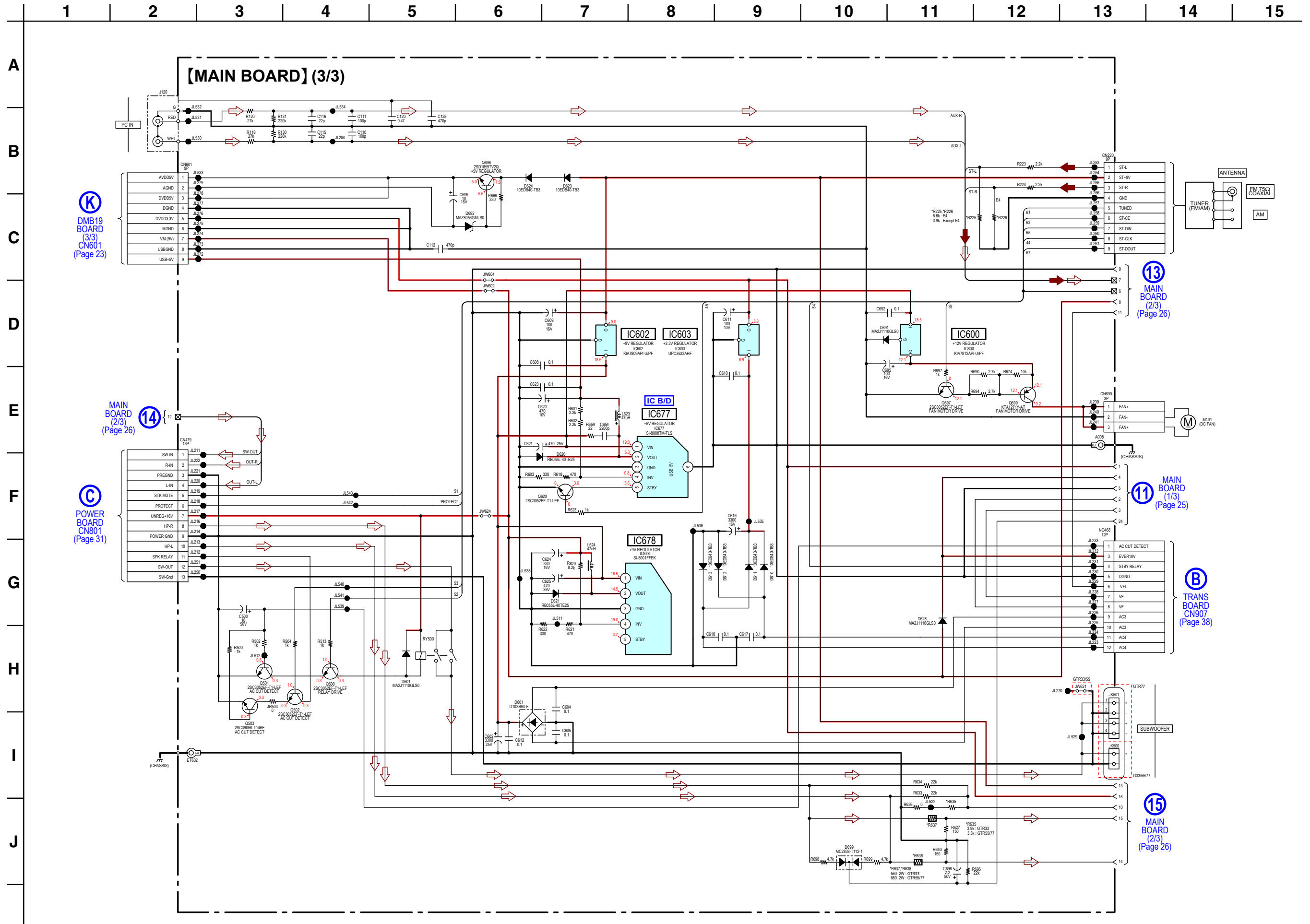

6-13. PRINTED WIRING BOARD - HUB Board - • See page 19 for Circuit Boards Location. •  : Uses unleaded solder.

	1	2	3	4	5	6	7	8	9	10	11	12	13	14	15
--	---	---	---	---	---	---	---	---	---	----	----	----	----	----	----

A
B
C
D
E
F
G
H
I
J

**【HUB BOARD】 (COMPONENT SIDE)**

**【HUB BOARD】 (CONDUCTOR SIDE)**

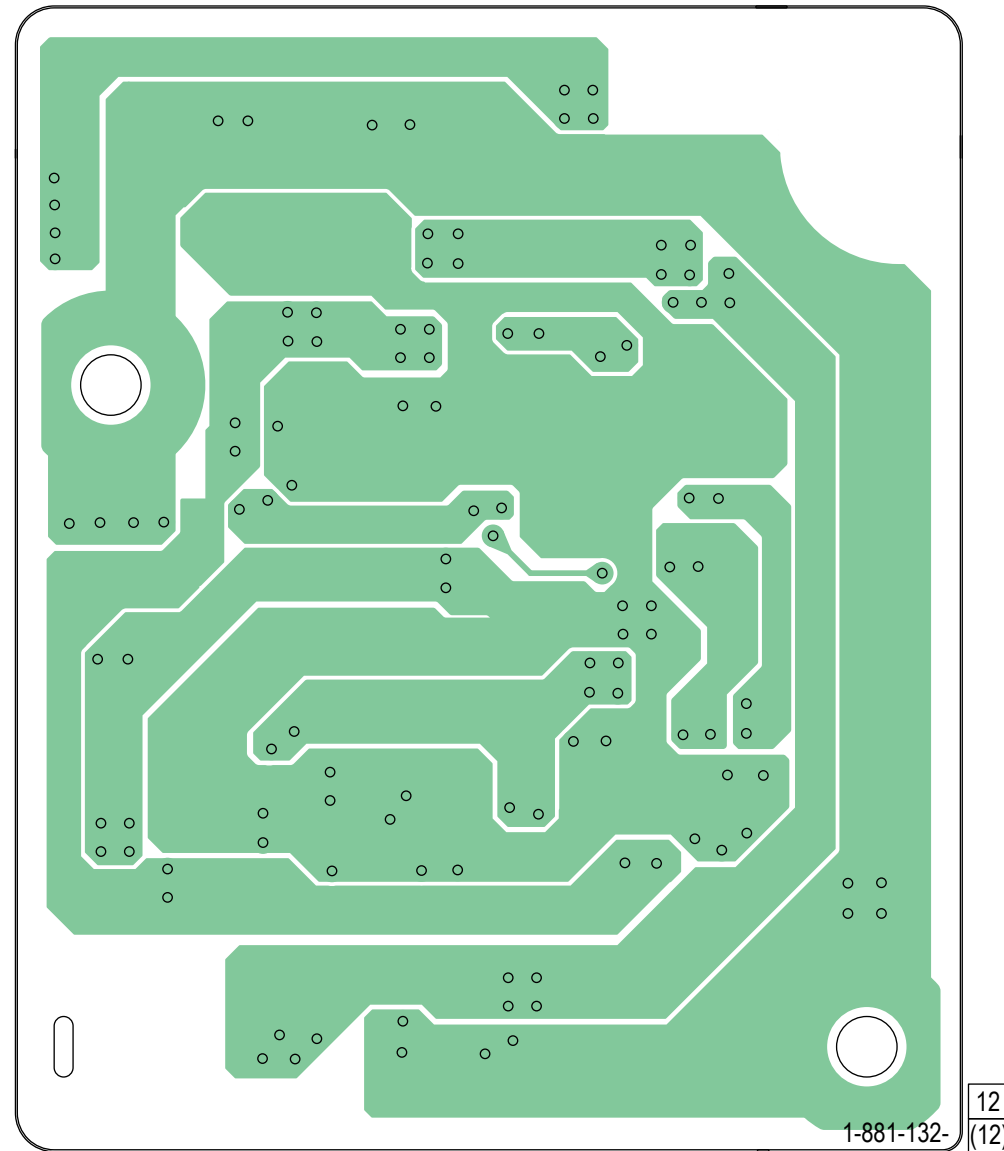
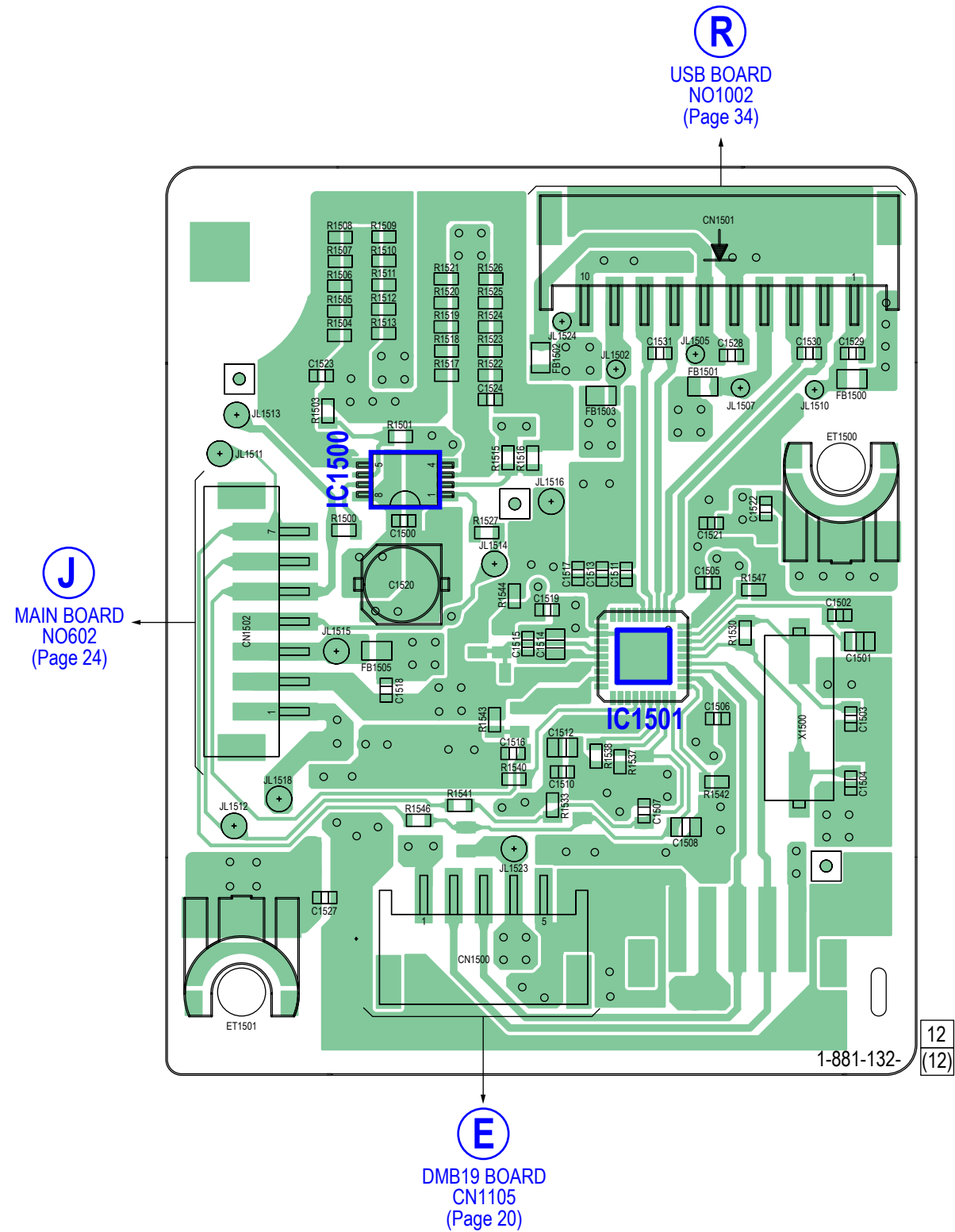

6-14. SCHEMATIC DIAGRAM - HUB Board - • See page 39 for Waveforms. • See page 40 for IC Pin Function Description.

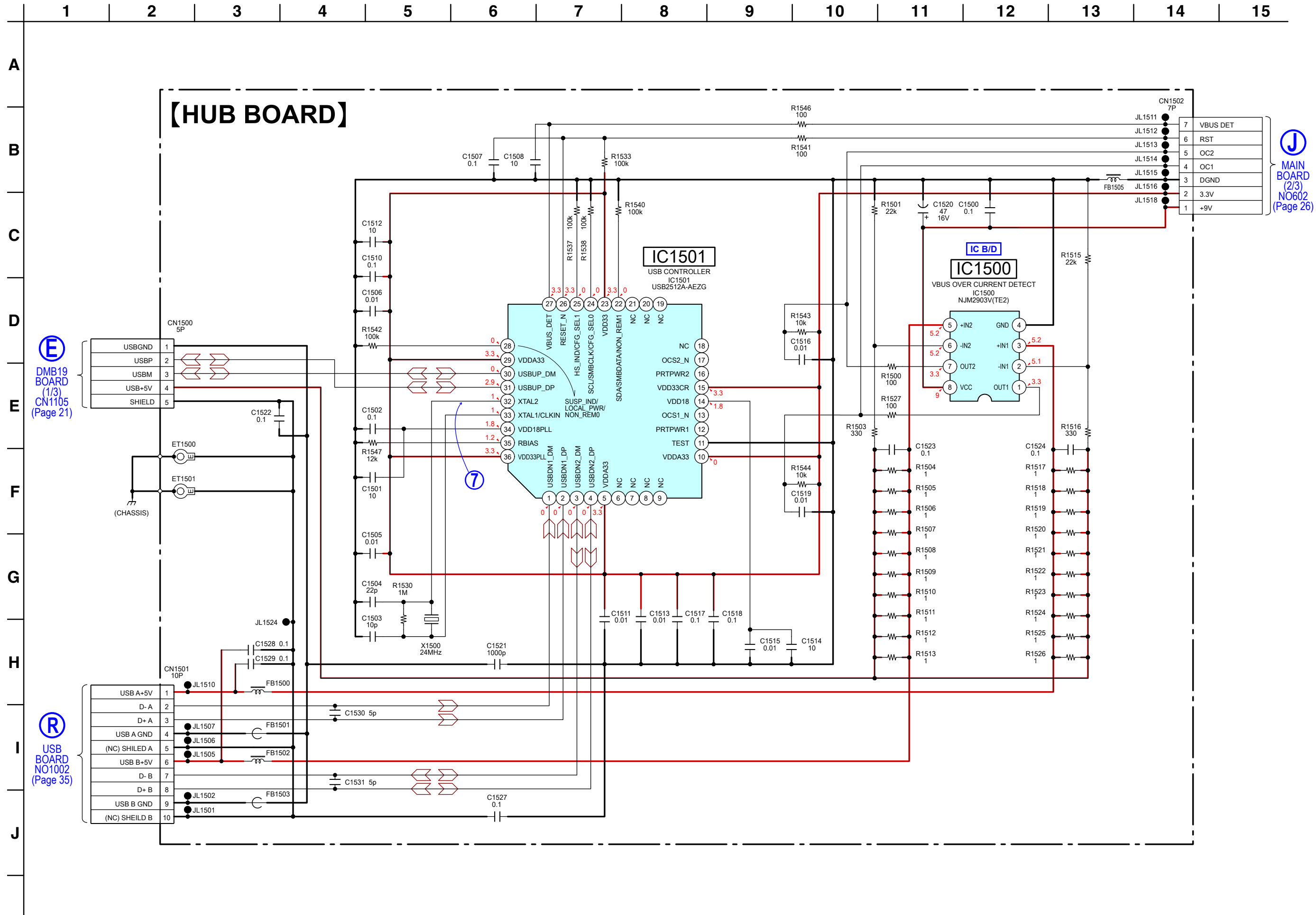

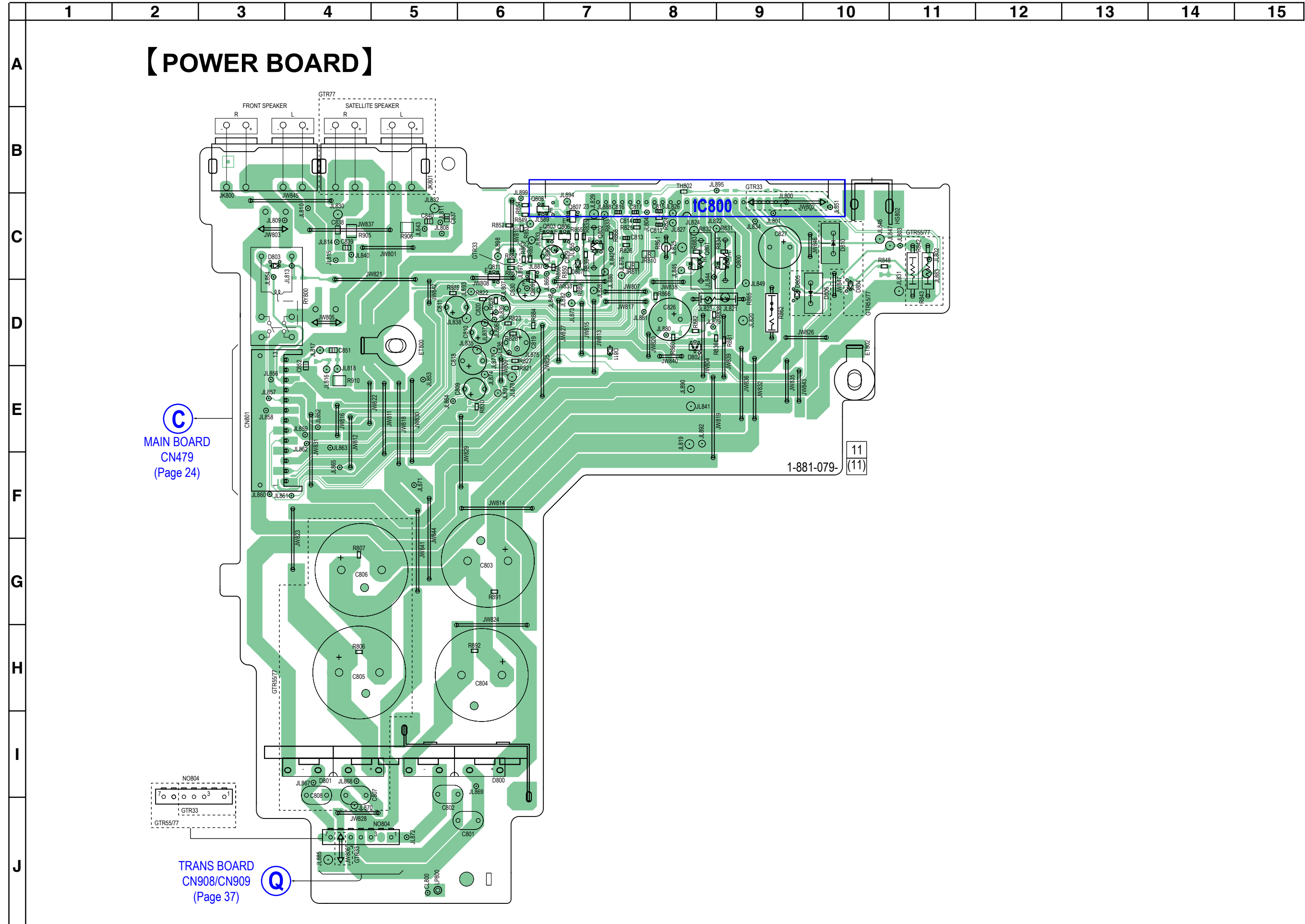

6-16. SCHEMATIC DIAGRAM - POWER Board -

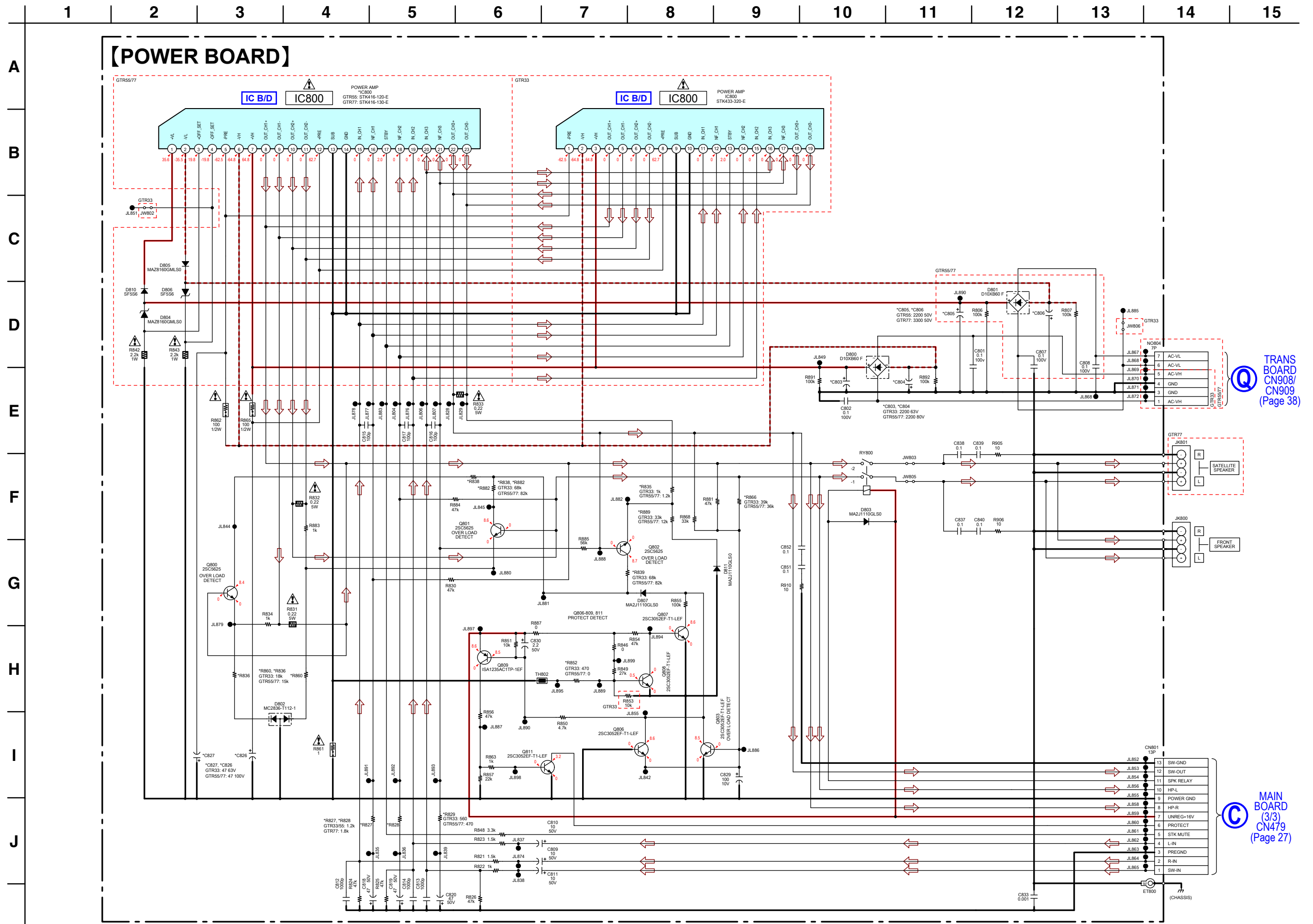

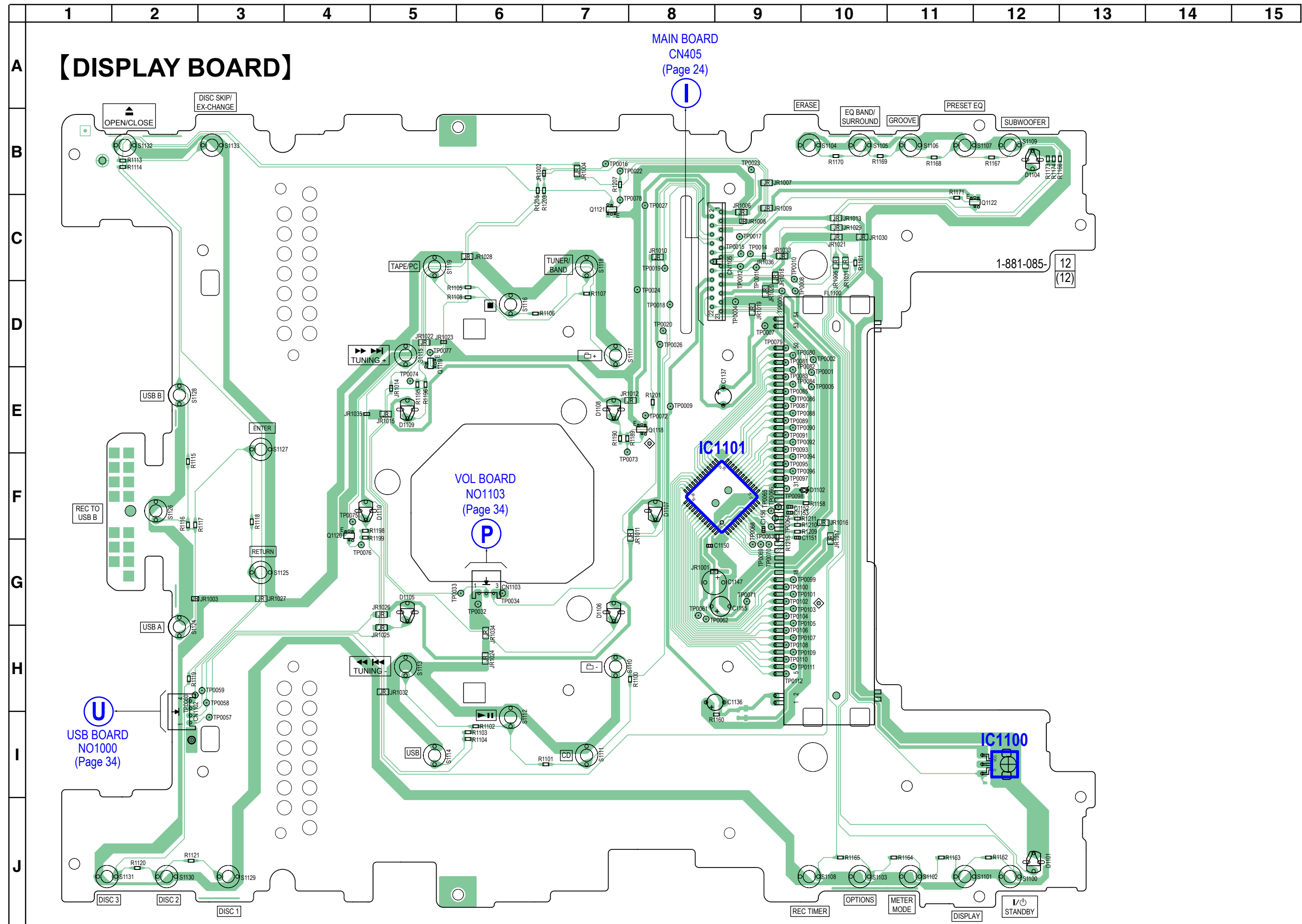



6-18. SCHEMATIC DIAGRAM - DISPLAY Board - See page 40 for IC Block Diagrams.

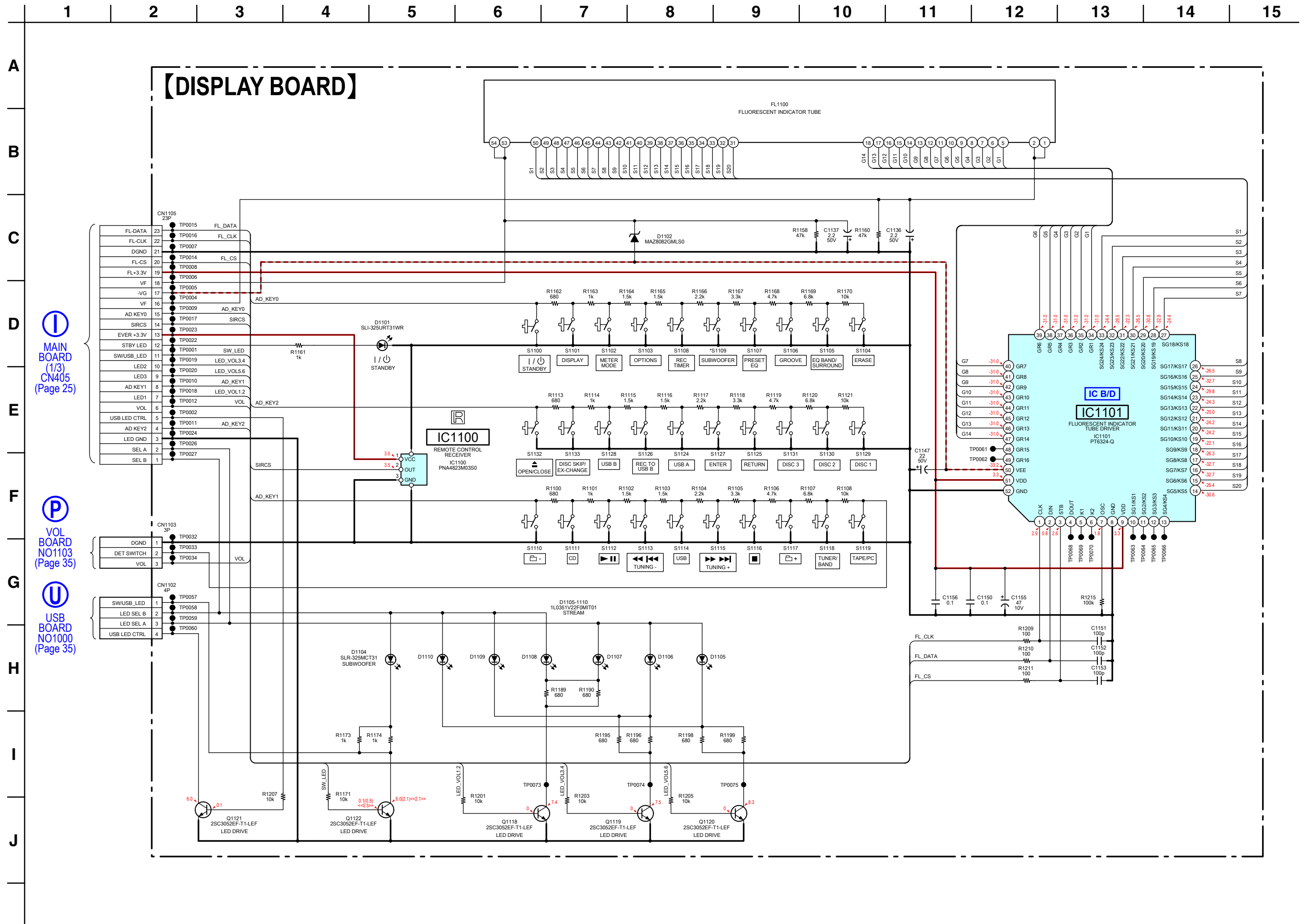

6-19. PRINTED WIRING BOARDS - MIC, USB AND VOL Board - • See page 19 for Circuit Boards Location. •  : Uses unleaded solder.

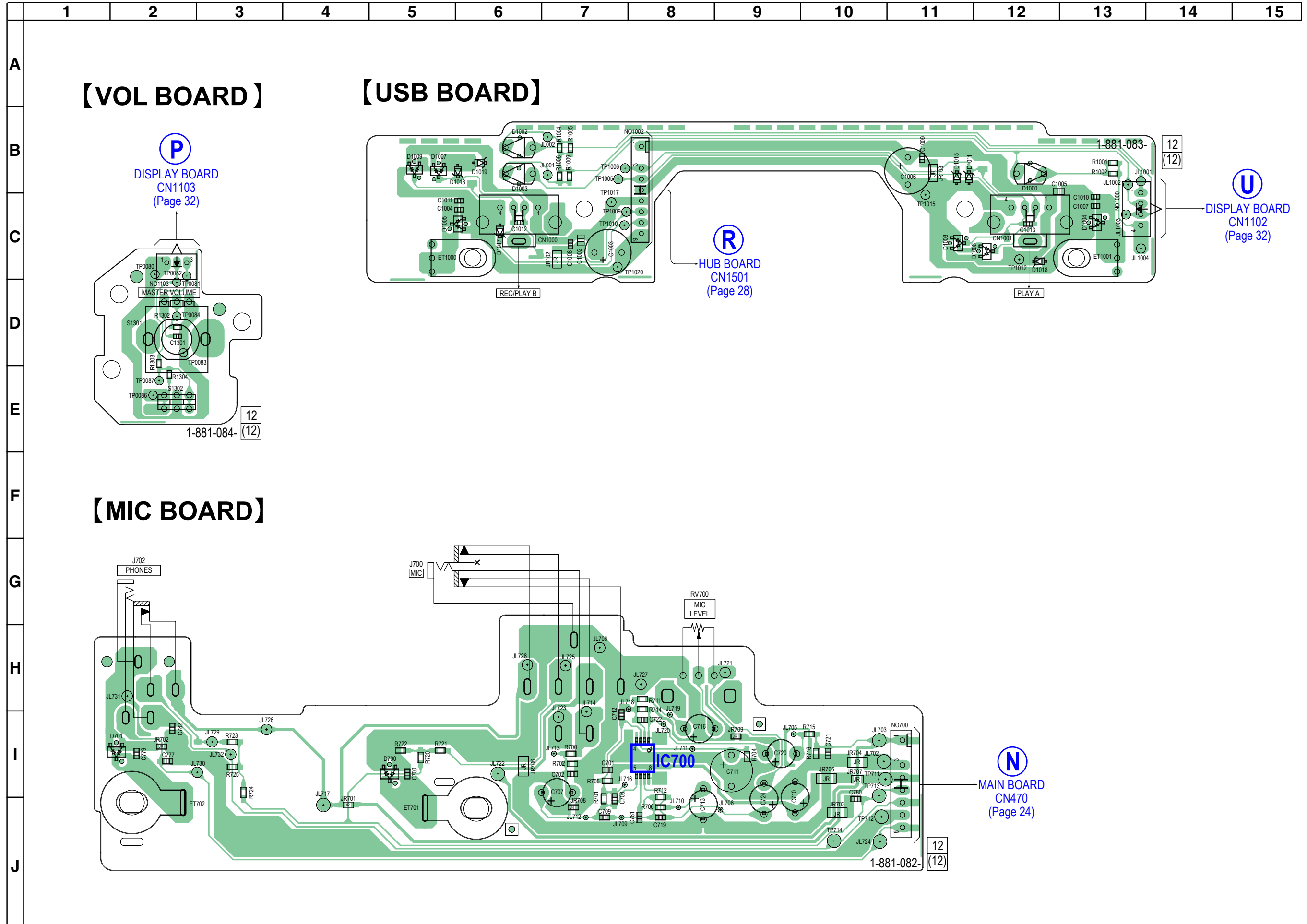

6-20. SCHEMATIC DIAGRAM - MIC, USB AND VOL Board - • See page 40 for IC Block Diagrams.

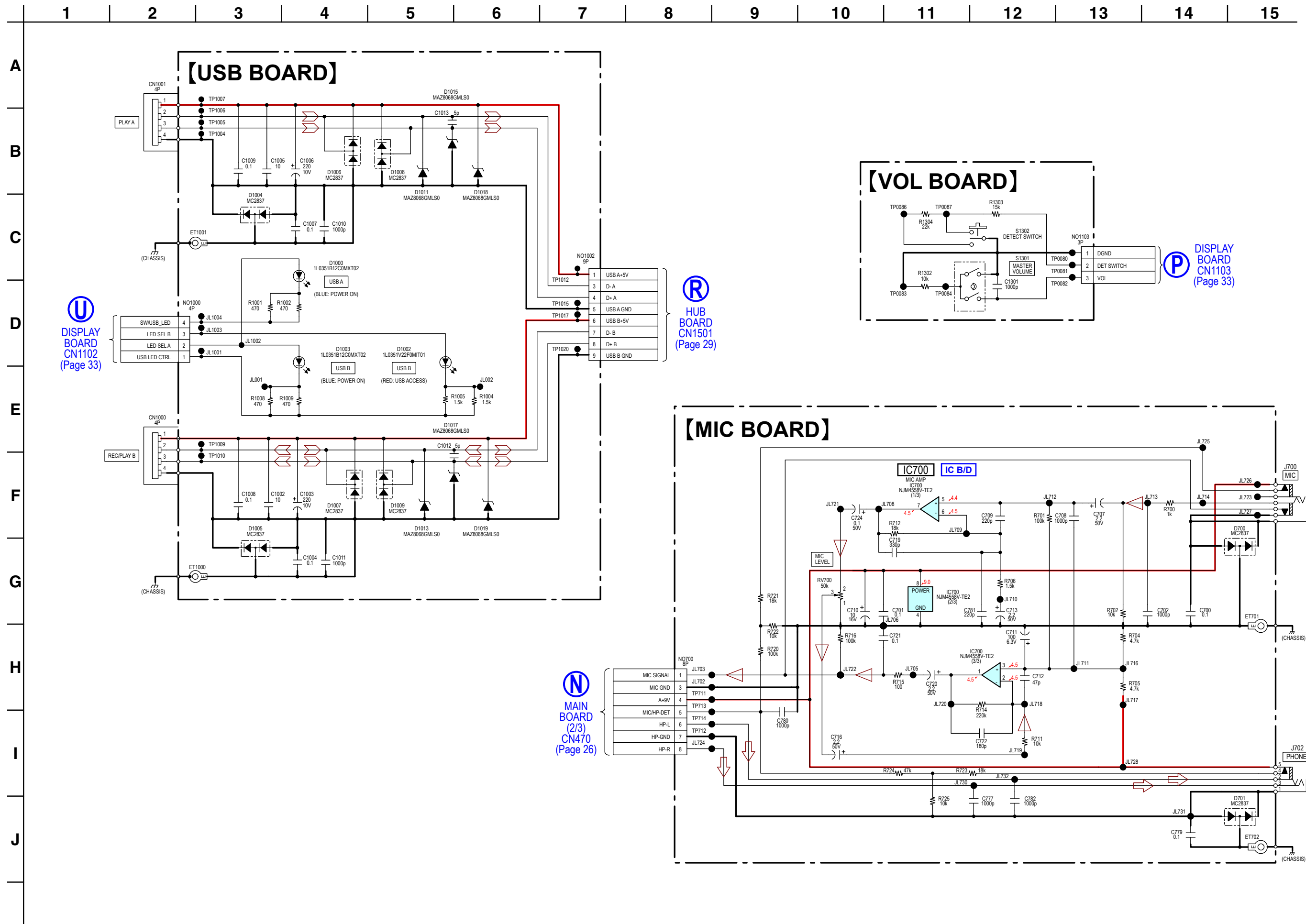

6-21. PRINTED WIRING BOARD - TC Board - (For African model only)

• See page 19 for Circuit Boards Location. •  : Uses unleaded solder.

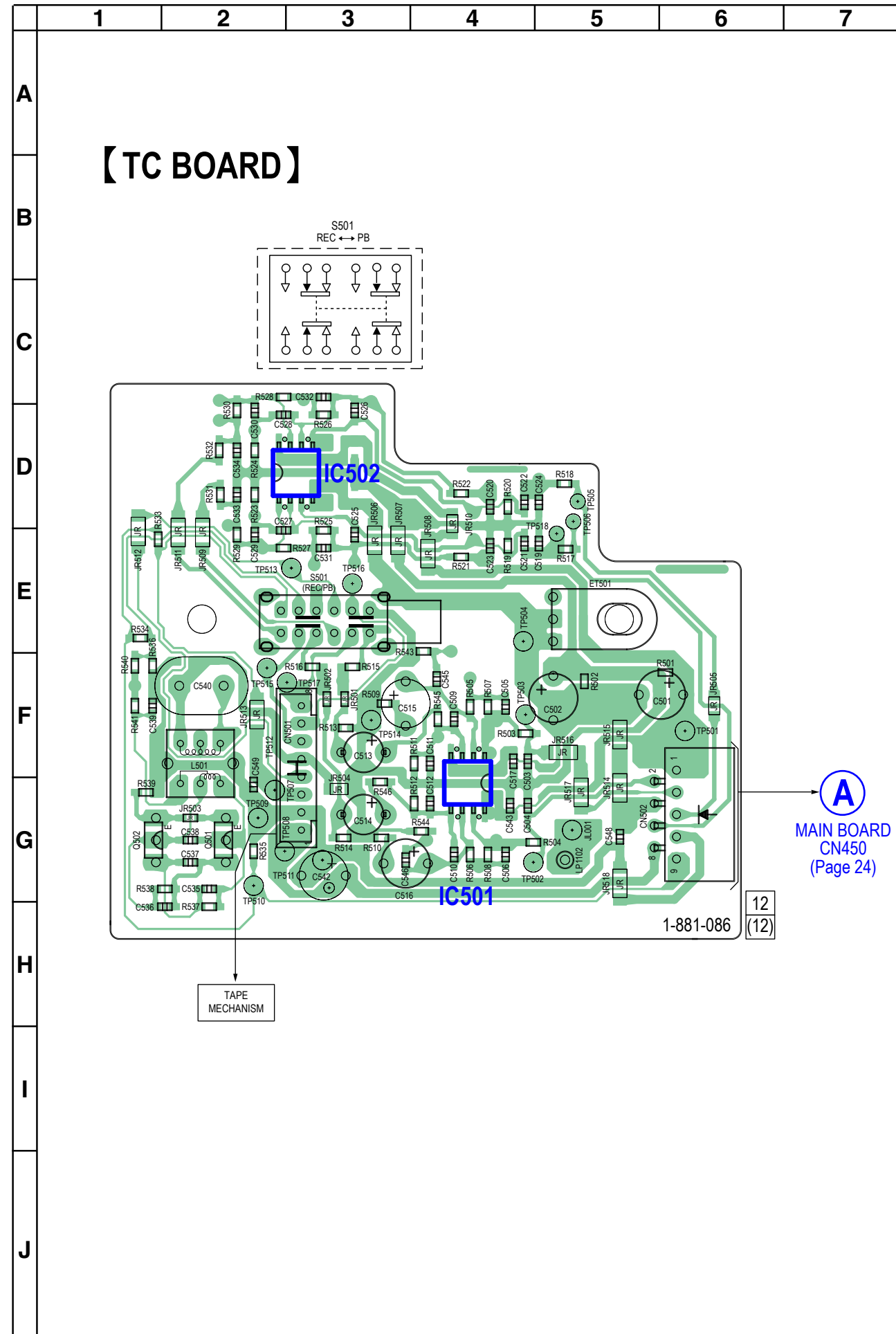

6-22. SCHEMATIC DIAGRAM - TC Board - (For African model only)

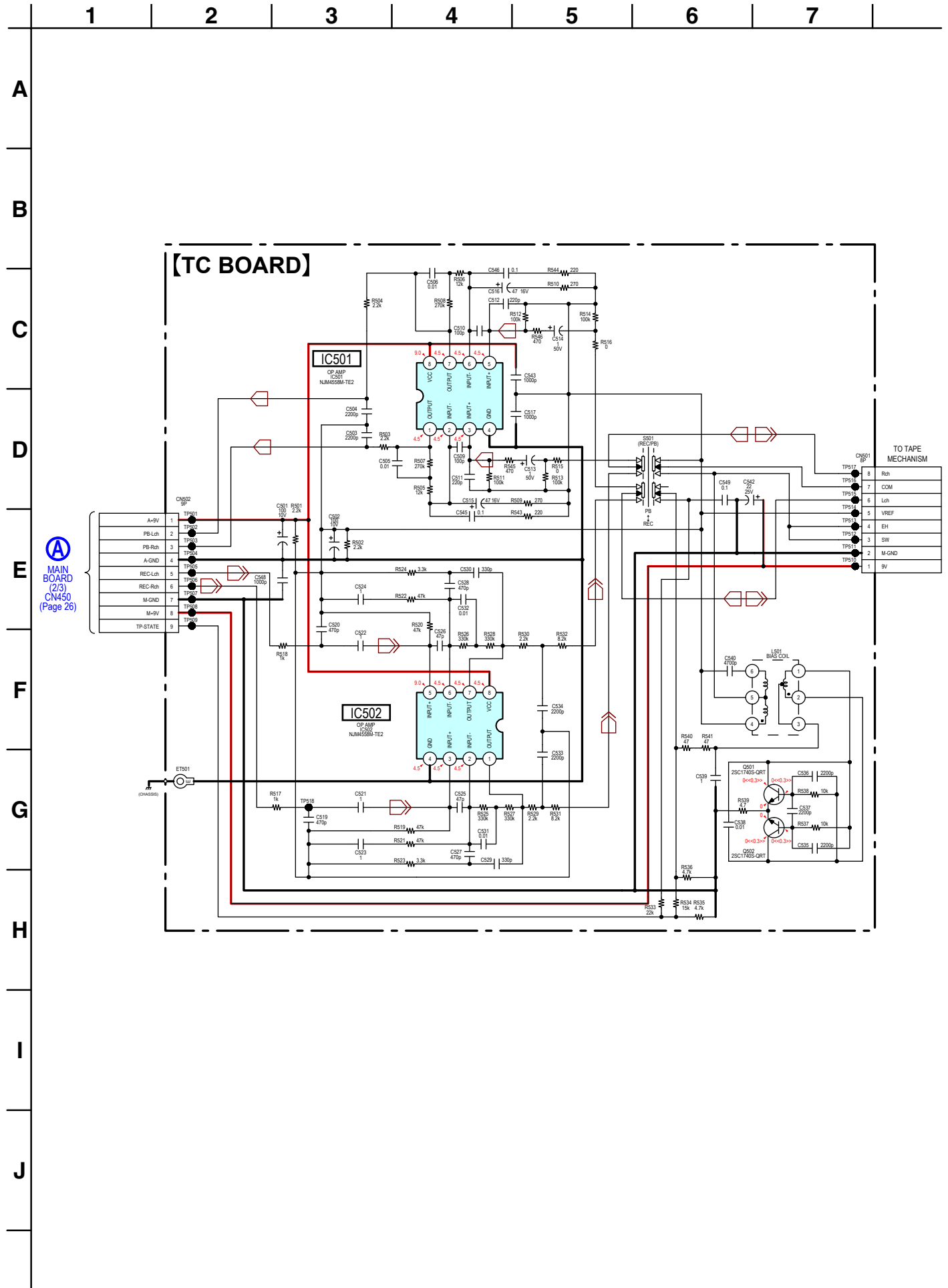

6-23. PRINTED WIRING BOARD - TRANS Board - • See page 19 for Circuit Boards Location. •  : Uses unleaded solder.

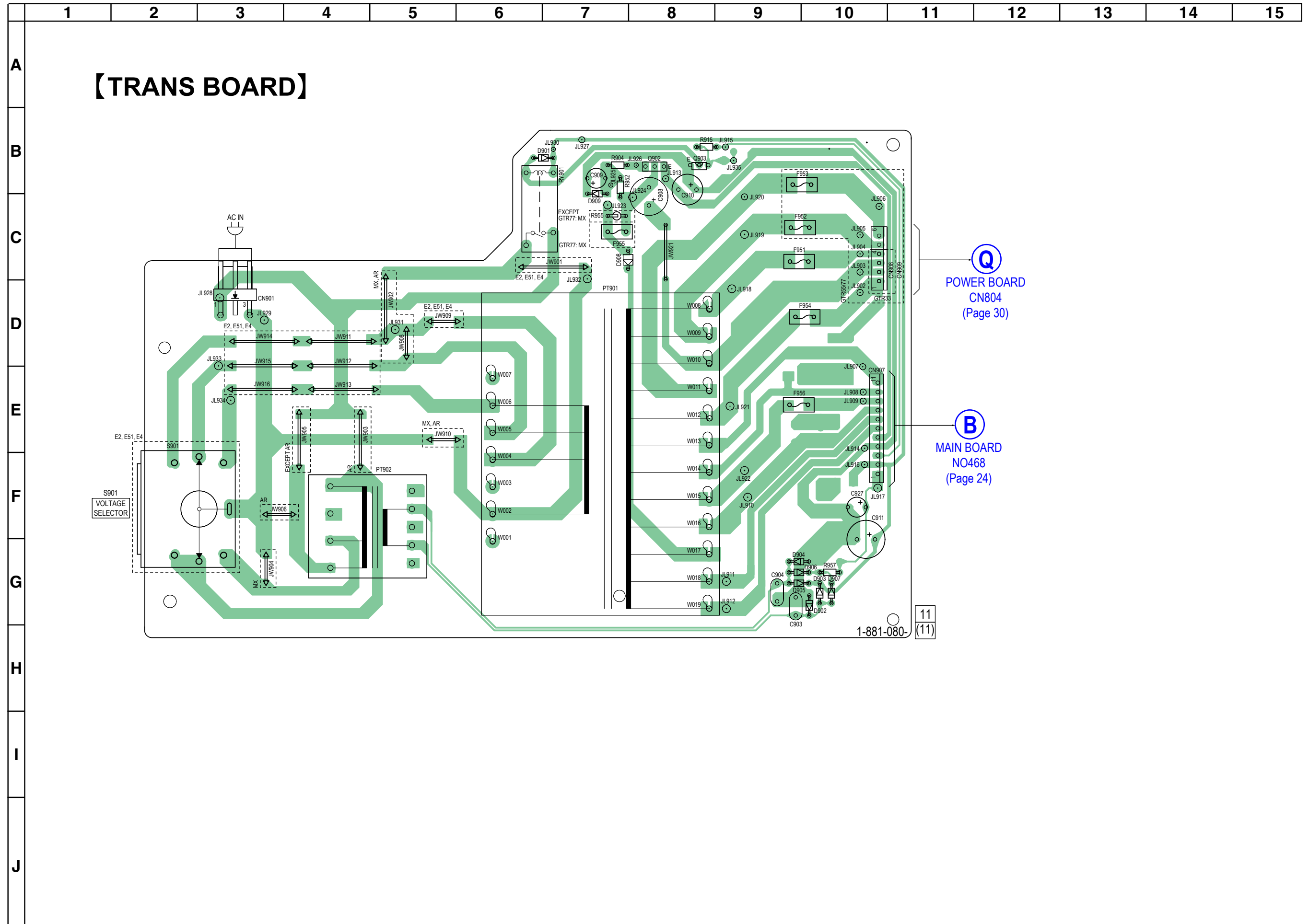

6-24. SCHEMATIC DIAGRAM - TRANS Board -

1 2 3 4 5 6 7 8 9 10 11 12 13 14 15

A

B

C

D

E

F

G

H

I

J

POWER BOARD NO804 (Page 31)

MAIN BOARD (3/3) NO468 (Page 27)

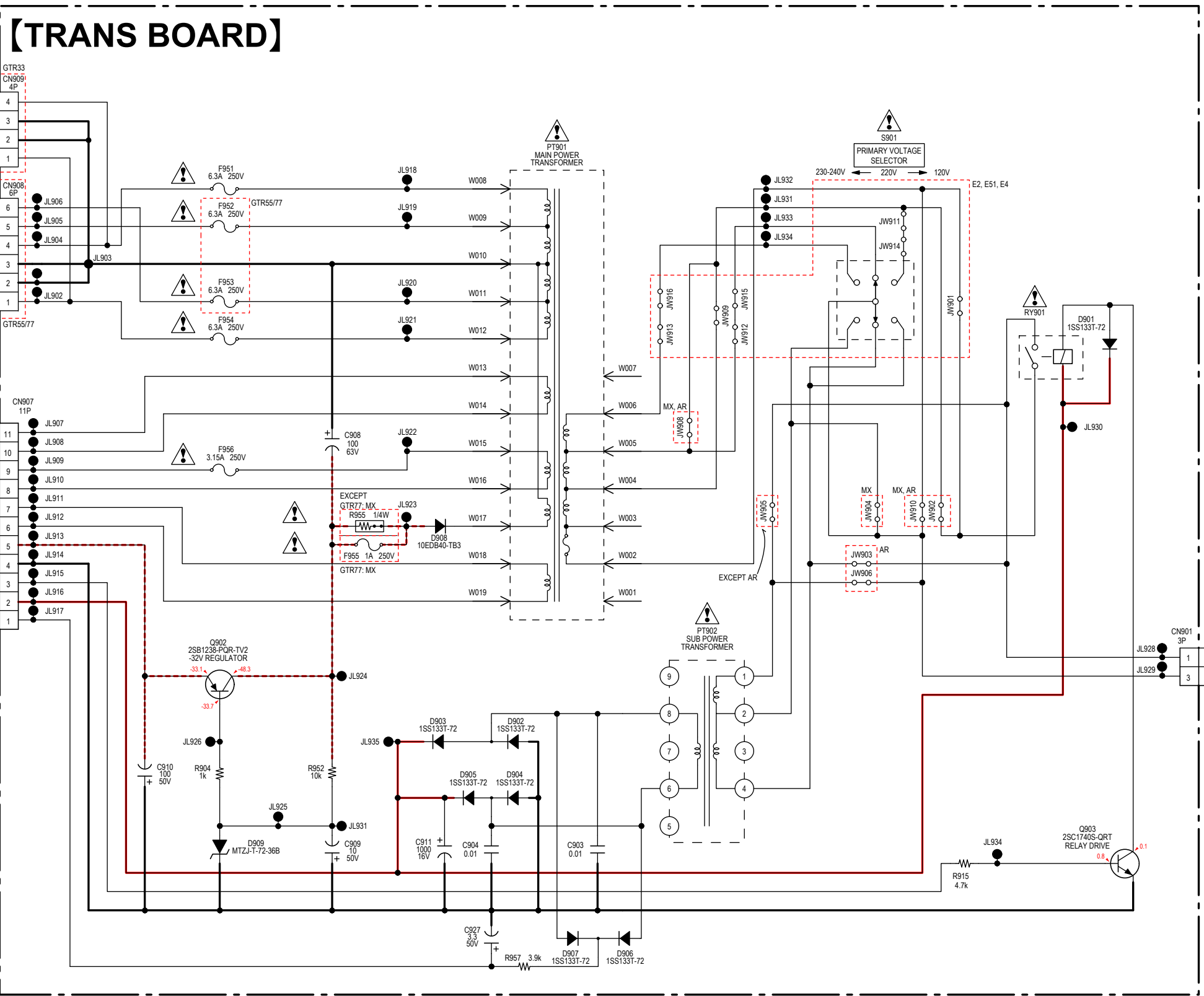



• Waveforms

– DMB19 Board –

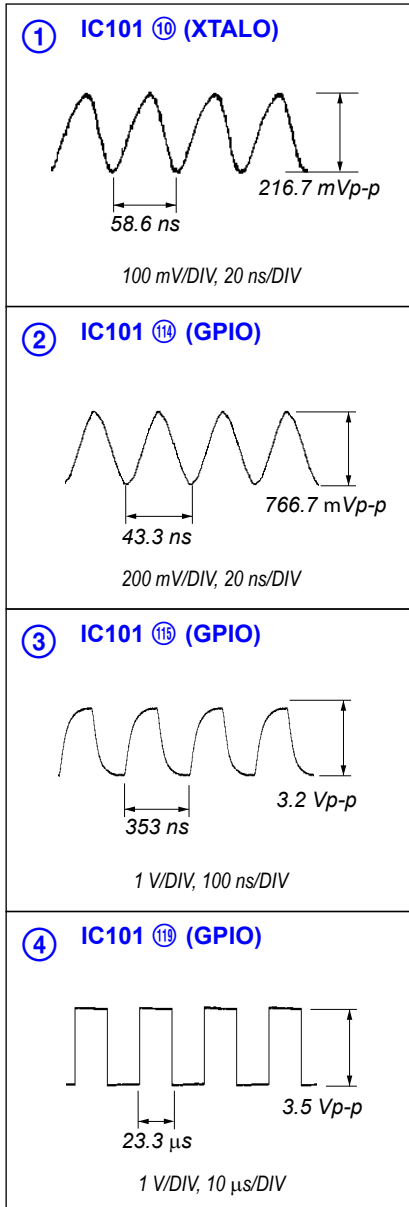

– MAIN Board –

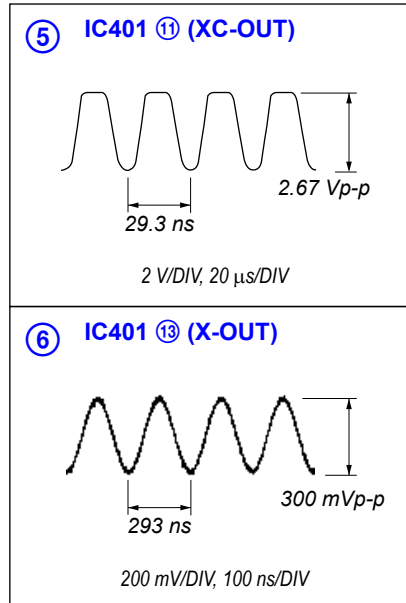

– HUB Board –

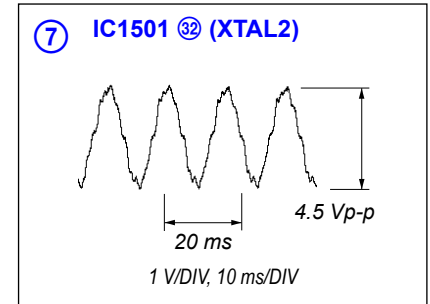

## • IC Block Diagrams

**IC107 TK11133CSCL-G (DMB19 Board (1/3))**

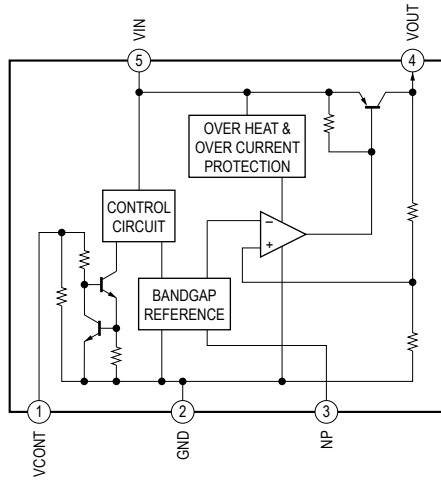

**IC111 MM1661JHBE (DMB19 Board (1/3))**

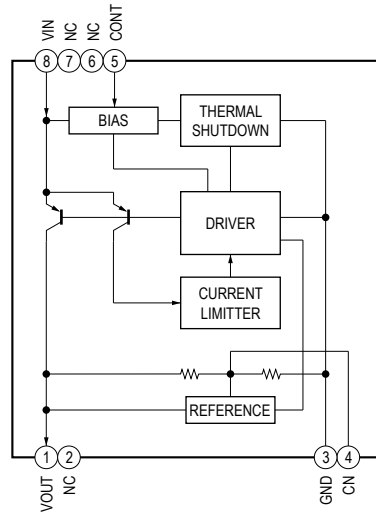

**IC4601 PCM1808PWR (DMB19 Board (3/3))**

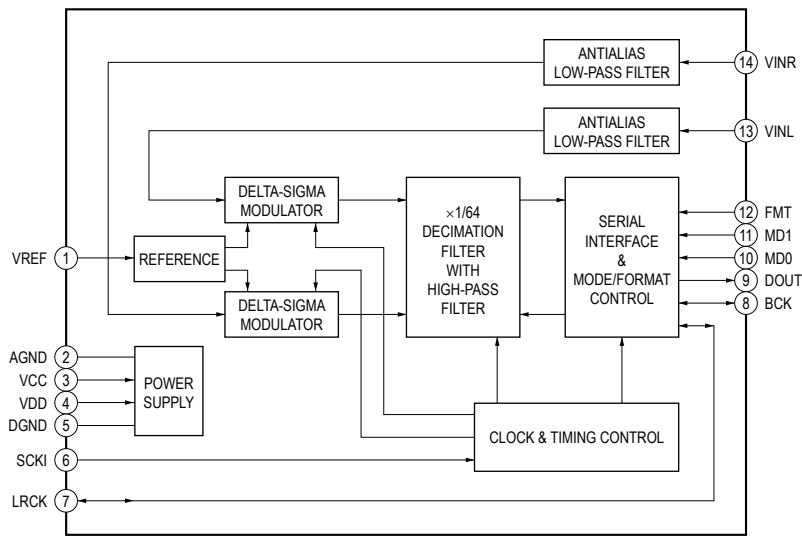

**IC4602 CS4335-KSZR (DMB19 Board (3/3))**

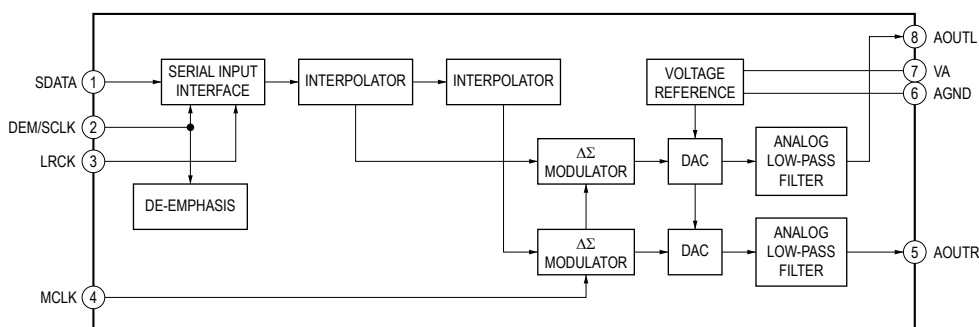

IC201 FAN8036L (DMB19 Board (2/3))

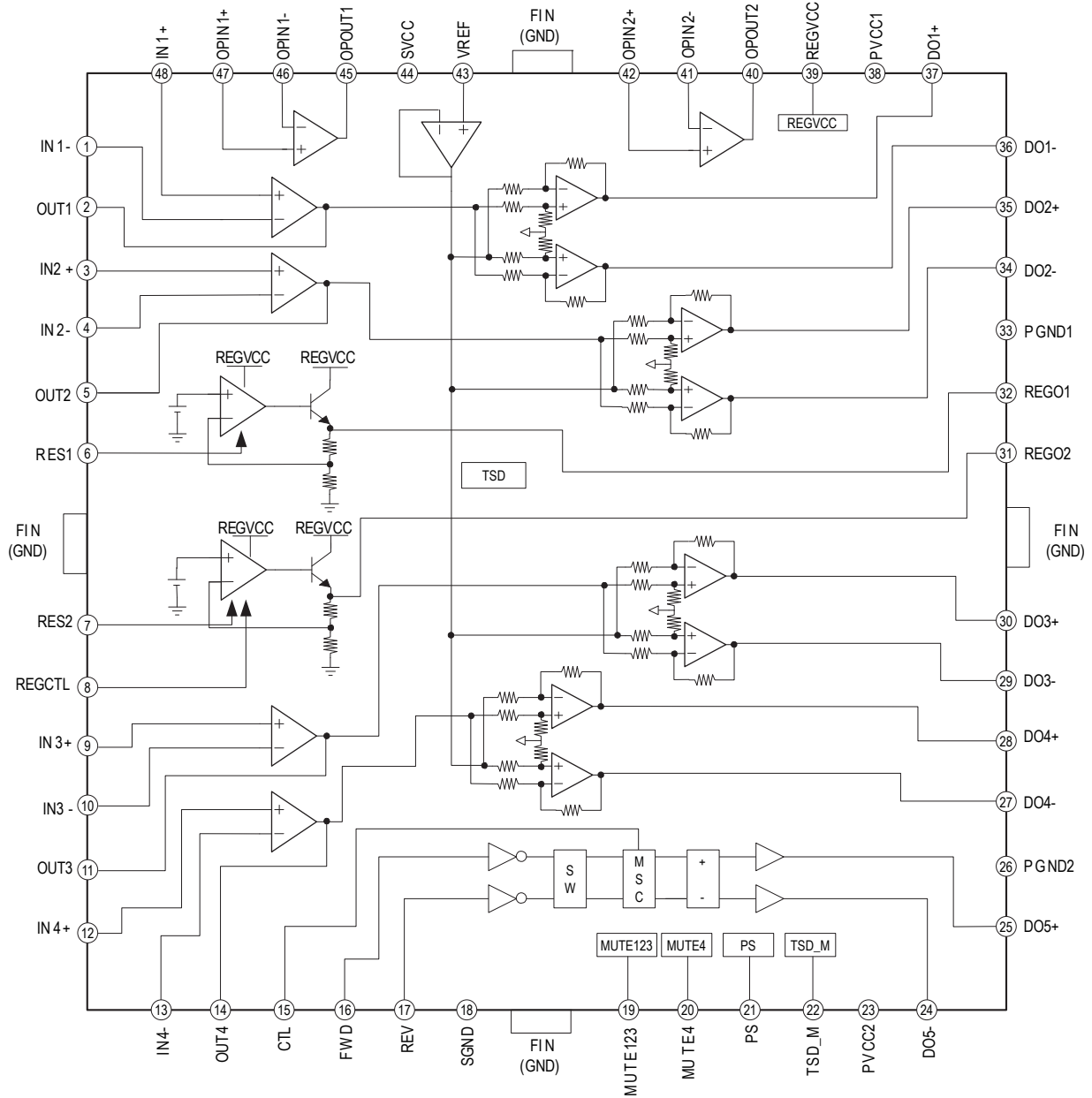

## IC407 R2A15216FP (MAIN Board (2/3))

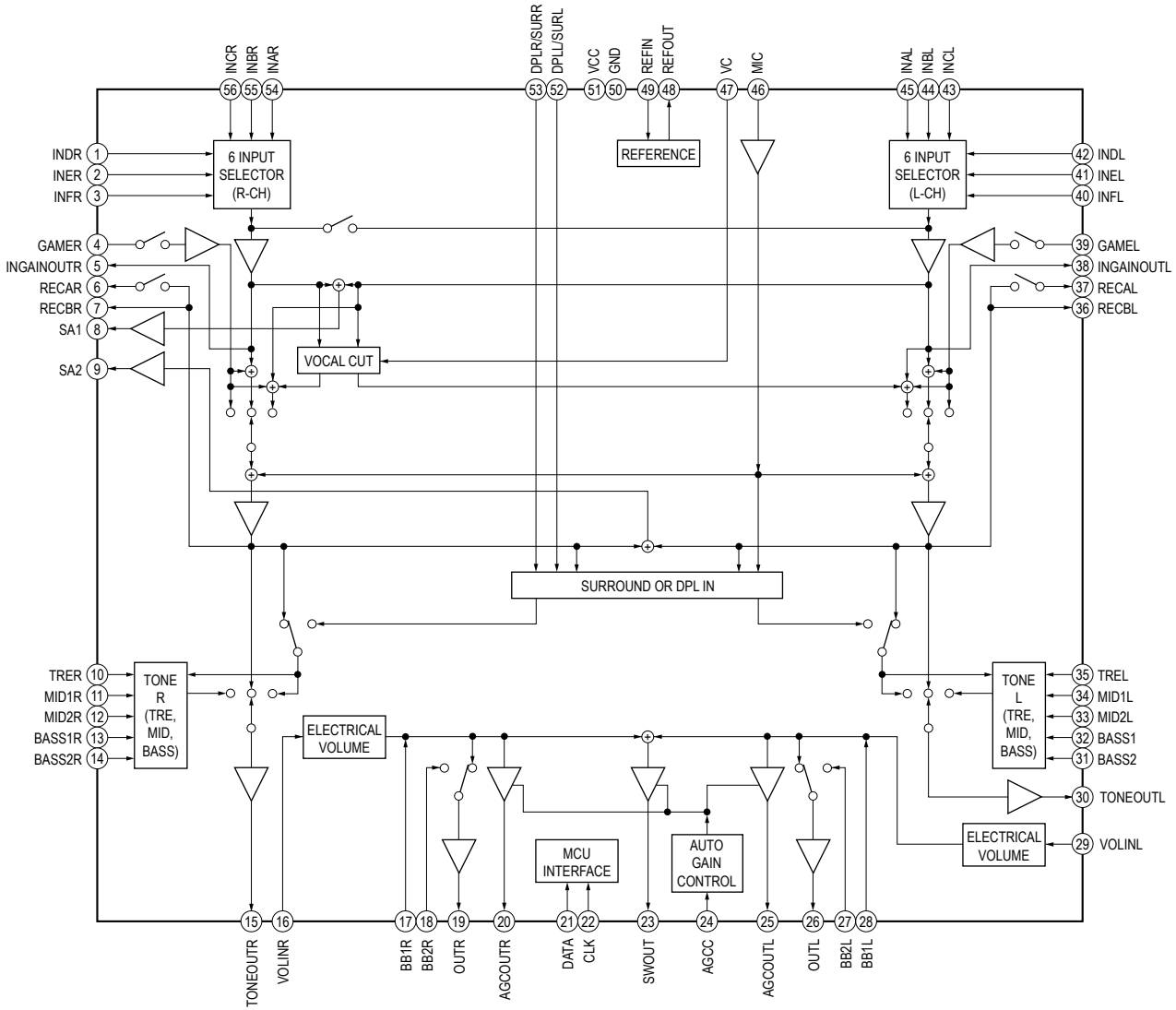

## IC677 SI-8008TM-TLS (MAIN Board (3/3))

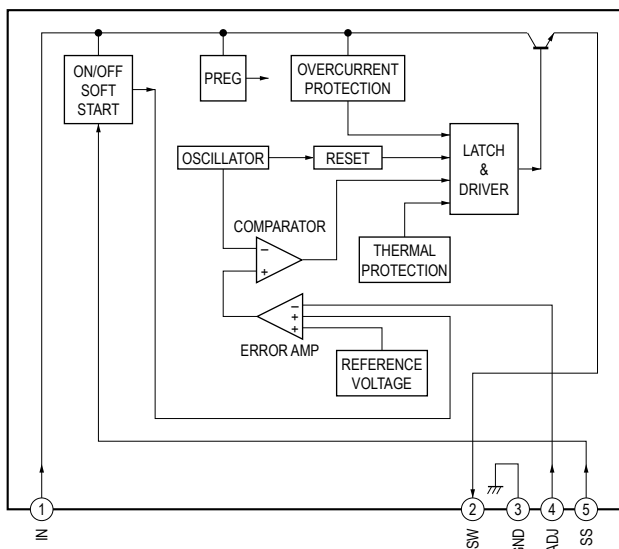

## IC252, IC253 NJM4558V-TE2 (MAIN Board (2/3)) IC700 NJM4558V-TE2 (MIC Board)

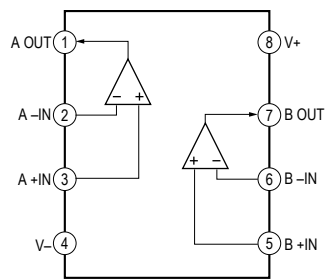

**IC800 STK433-320-E (POWER Board) (GTR33)**

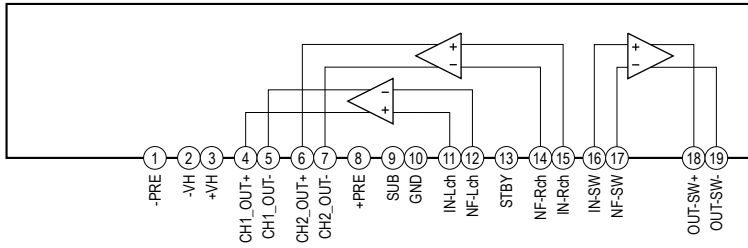

**IC800 STK416-130-E (POWER Board) (GTR77)  
IC800 STK416-120-E (POWER Board) (GTR55)**

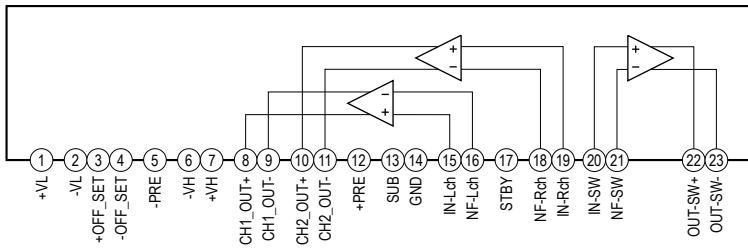

**IC1500 NJM2903V (TE2) (HUB Board)**

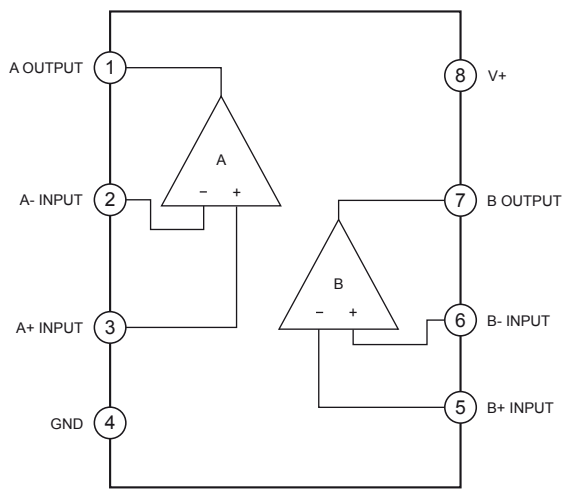

**IC1101 PT6324-Q (DISPLAY Board)**

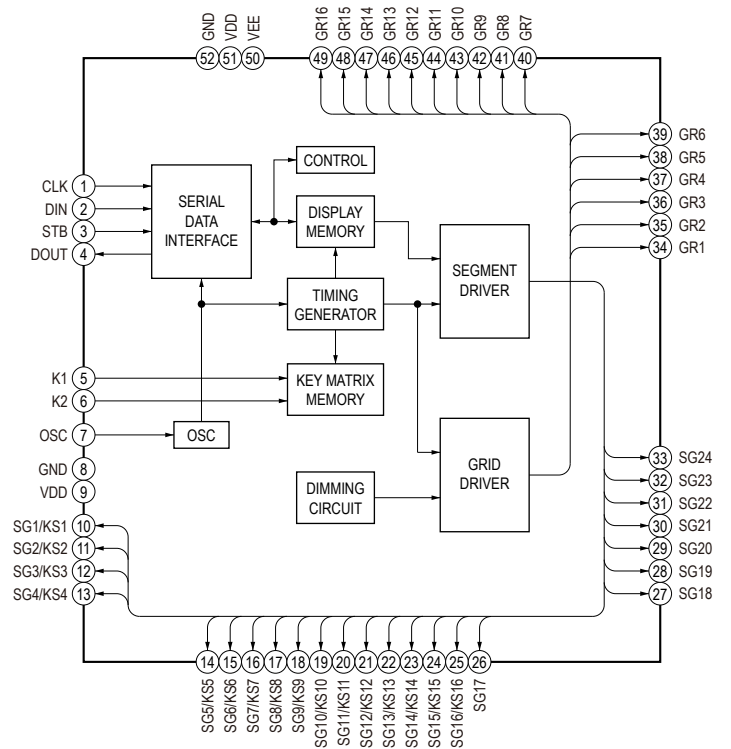

## • IC Pin Function Description

### DMB19 BOARD (1/3) IC101 CXD9968R (LE) (RF AMP, SERVO DSP, AUDIO PROCESSOR)

Pin No.	Pin Name	I/O	Description
1	RF_A	I	RF main beam (C) input from the optical pick-up block
2	RF_B	I	RF main beam (B) input from the optical pick-up block
3	RF_C	I	RF main beam (A) input from the optical pick-up block
4	RF_D	I	RF main beam (D) input from the optical pick-up block
5	RF_E	I	RF sub beam (F) input from the optical pick-up block
6	RF_F	I	RF sub beam (E) input from the optical pick-up block
7	AVDD18_2	-	Power supply terminal (+1.8V)
8	AVDD33_1	-	Power supply terminal (+3.3V)
9	XTALI	I	System clock input terminal (27 MHz)
10	XTALO	O	System clock output terminal (27 MHz)
11	AGND33	-	Ground terminal
12	V2O	O	Reference voltage (+2V) output to the optical pick-up block
13	V14/VREFO	O	Reference voltage (+1.4V) output terminal
14	REXT	I	Current reference input terminal Fixed at "L" in this set
15, 16	MDI1, MDI2	I	Laser power monitor input from the optical pick-up block
17, 18	LDO1, LDO2	O	Laser diode drive signal output to the optical pick-up block
19	AVDD33_2	-	Power supply terminal (+3.3V)
20	DMO	O	Spindle motor control signal output to the motor driver
21	FMO	O	Sled motor control signal output to the motor driver
22	MUTE4	O	Muting signal output to the coil/motor driver (for spindle motor)
23	MSW	O	CD/DVD selection signal output terminal "L": CD, "H": DVD
24	TRO	O	Tracking coil control signal output to the coil driver
25	FOO	O	Focus coil control signal output to the coil driver
26	EEWP	-	Not used
27, 28	USB_DP, USB_DM	I/O	Two-way audio serial data with the USB controller
29	VDD33_USB	-	Power supply terminal (+3.3V)
30	VSS33_USB	-	Ground terminal
31	PAD_VRT	I/O	USB generating reference current terminal
32	VDD18_USB	-	Power supply terminal (+1.8V)
33	SCL	O	Serial clock signal output to the EEPROM (GTZ4i)
34	SDA	I/O	Two-way serial data with the EEPROM (GTZ4i)
35	IFSDI	I	Serial data input from the system controller
36	FS_CS#	O	Chip select signal output to the flash ROM
37	SF_DO	O	Serial data output to the flash ROM
38	SF_DI	I	Serial data input from the flash ROM
39	SF_CK	O	Serial clock signal output to the flash ROM
40	IFSCK	O	Serial data transfer clock signal output to the system controller
41	IFSOD	O	Serial data output to the system controller
42	ICE	I	ICE mode enable setting terminal Not used
43	PRST#	I	Reset signal input from the system controller "L": reset
44	IR	I	IR control signal input terminal Not used
45 to 49	RD0 to RD4	I/O	Two-way data bus with the SD-RAM
50	DVDD33	-	Power supply terminal (+3.3V)
51 to 53	RD5 to RD7	I/O	Two-way data bus with the SD-RAM
54	DVDD18	-	Power supply terminal (+1.8V)
55	DQM0	O	Data mask signal output to the SD-RAM
56 to 59	RD15 to RD 12	I/O	Two-way data bus with the SD-RAM
60	DVSS33	-	Ground terminal
61 to 64	RD11 to RD8	I/O	Two-way data bus with the SD-RAM
65	DQM1	O	Data mask signal output to the SD-RAM
66	RCLK	O	Clock signal output to the SD-RAM
67	RA11	O	Address signal output to the SD-RAM
68	DVDD33	-	Power supply terminal (+3.3V)
69 to 74	RA9 to RA4	O	Address signal output to the SD-RAM
75	RWE#	O	Write enable signal output to the SD-RAM
76	CAS#	O	Column address strobe signal output to the SD-RAM
77	RAS#	O	Row address strobe signal output to the SD-RAM



Pin No.	Pin Name	I/O	Description
78	BA0	O	Bank address signal output to the SD-RAM
79	DVSS18	-	Ground terminal
80	BA1	O	Bank address signal output to the SD-RAM
81 to 83	RA10, RA0, RA1	O	Address signal output to the SD-RAM
84	DVDD33	-	Power supply terminal (+3.3V)
85, 86	RA2, RA3	O	Address signal output to the SD-RAM
87	IFBSY	I	Communication initialization request signal input from the system controller
88	IFCS#	O	Communication initialization request acknowledge signal output to the system controller
89	RX	-	Not used
90	DVDD18	-	Power supply terminal (+1.8V)
91	TX	-	Not used
92	XMAMUTE	-	Not used
93	SPDIF	O	SPDIF signal output terminal Not used
94	GPIO	I	Thermal shut down signal input from the coil/motor driver
95	DACVDDC	-	Power supply terminal (+3.3V)
96	VREF	I	Band gap reference voltage terminal
97	FS	I	Full scale adjustment terminal
98	DACVSSC	-	Ground terminal
99	CVBS	O	Composite video signal output terminal Not used
100, 101	DACVDDB, DACVDDA	-	Power supply terminal (+3.3V)
102	SY/Y/G	O	Component video (Y) signal output terminal Not used
103	SC/CB/B	O	Component video (Pb/Cb) signal output terminal Not used
104	CR/R	O	Component video (Pr/Cr) signal output terminal Not used
105	AADVSS	-	Ground terminal
106	GPIO19	I	Audio data input from the A/D converter (for USB)
107	MUTE123	-	Not used
108	LIMITSW	-	Not used
109, 110	AADVDD, APLLVDD	-	Power supply terminal (+3.3V)
111	APLLCAP	I	External capacitor connecting terminal
112, 113	ADACVSS2, ADACVSS1	-	Ground terminal
114	GPIO	O	Master clock signal output to the A/D converter and D/A converter
115	GPIO	O	Bit clock signal output to the A/D converter and D/A converter
116	GPIO	O	Muting signal output to the coil/motor driver (for focus/tracking coil and sled motor)
117	AVCM	-	Audio D/A converter reference voltage terminal
118	GPIO	I	Limit detection switch input terminal
119	GPIO	O	L/R sampling clock signal output to the A/D converter and D/A converter
120	GPIO	O	Audio data output to the D/A converter
121, 122	ADACVDD1, ADACVDD2	-	Power supply terminal (+3.3V)
123	AVDD18_1	-	Power supply terminal (+1.8V)
124	AGND18	-	Ground terminal
125, 126	RF_IP, OPOUT	I	AC coupled RF signal input from the optical pick-up block
127	IOPMON/OPINP	I	Power monitor terminal
128	SPFG/OPINN	I	Spindle motor hall sensor input from the motor driver

# HCD-GTR33/GTR55/GTR77

## HUB BOARD IC1501 USB2512A-AEZG (USB CONTROLLER)

Pin No.	Pin Name	I/O	Description
1, 2	USBDN1_DM, USBDN1_DP	I	Audio serial data input from the USB A connector
3, 4	USBDN2_DM, USBDN2_DP	I/O	Two-way audio serial data with the USB B connector
5	VDDA33	-	Power supply terminal (+3.3V)
6 to 9	NC	-	Not used
10	VDDA33	-	Power supply terminal (+3.3V)
11	TEST	-	Not used
12	PRTPOWER1	O	Not used
13	OCS1_N	I	Over current sense signal input from the USB interface
14	VDD18	-	Power supply terminal (+1.8V)
15	VDD33CR	-	Power supply terminal (+3.3V)
16	PRTPOWER2	O	Not used
17	OCS2_N	I	Over current sense signal input terminal
18 to 21	NC	-	Not used
22	SDA/SMBDATA/ NON/REM1	-	Not used
23	VDD33	-	Power supply terminal (+3.3V)
24	SCL/SMBCLK/ CFG_SELO	-	Not used
25	HS_IND/CFG_SEL1	-	Not used
26	RESET_N	I	Reset signal input from the system controller "L": reset
27	VBUS_DET	I	VBUS voltage detect signal input from the system controller
28	SUSP_IND/LOCAL_ PWR/NON_PEM0	-	Not used
29	VDDA33	-	Power supply terminal (+3.3V)
30, 31	USBUP_DM, USBUP_DP	I/O	Two-way audio serial data with the audio processor
32	XTAL2	O	System clock (24 MHz) output terminal
33	XTAL1/CLKIN	I	System clock (24 MHz) input terminal
34	VDD18PLL	-	Power supply terminal (+1.8V)
35	RBIAS	-	Not used
36	VDD33PLL	-	Power supply terminal (+3.3V)

## MAIN BOARD (1/3) IC401 R5F364AEDFA (SYSTEM CONTROLLER)

Pin No.	Pin Name	I/O	Description
1	FL-DRIVER-CS	O	Serial data chip select signal to FL Driver, PT6324
2	FL-DRIVER-CLK	O	Serial data clock signal to FL Driver, PT6324
3	FL-DRIVER-DATA	O	Serial data output signal to FL Driver, PT6324
4	SIRCS	I	Remote control signal input
5	CDM-SD	I	CDM protector detection input signal "H": protector on
6	M2-	O	Disc change and mode change motor control signal output
7	M2+	O	Disc change and mode change motor control signal output
8	BYTE	-	Ground terminal
9	CNVss	-	Ground terminal
10	XC-IN	I	Sub system clock input terminal (32.768kHz)
11	XC-OUT	O	Sub system clock output terminal (32.768kHz)
12	RESET	I	System reset signal input from the reset signal IC "L": reset After the power supply rises, "L" is input for several hundreds msec and then change to "H".
13	X-OUT	O	Main system clock output terminal (8MHz)
14	VSS	-	Ground terminal
15	X-IN	I	Main system clock input terminal (8MHz)
16	VCC	-	Power supply terminal (+3.3V)
17	NMI	I	Non-maskable interrupt input terminal
18	M1-	O	Tray/drawer transportation motor control signal output
19	MTK-BSY	O	BUSY Signal communication between MTK Board
20	AC-CUT	I	AC off detection signal input from the reset signal IC "L": AC Cut detected
21	M1+	O	Tray/drawer transportation motor control signal output
22	SW3	I	Disc change and mode change detection signal input from CDM
23	SW1	I	Disc change and mode change detection signal input from CDM
24	SW-CHUCK	I	Tray chuck position detection signal from CDM
25	SW2	I	Disc change and mode change detection signal input from CDM
26	SW-CLOSE	I	Drawer close position detection signal input from CDM
27	SW-STOCK	I	Tray stock position detection signal from CDM
28	SW-OPEN	I	Drawer open position detection signal input from CDM
29	IIC-CLK	I/O	Serial data transfer clock signal output terminal
30	IIC-DATA	I/O	Serial data output terminal
31	METER BL CTL	O	Meter Backlight LED control signal. "H" LED ON (Only for HCD-GTR55 and HCD-GTR77 model)
32	NO-USE	-	Unused
33	NO-USE	-	Unused
34	MTK-XIFCS	I	Chip Select Signal from MTK DMB Board
35	MTK-SOD	O	Data Out Signal to MTK DMB Board
36	MTK-SIO	I	Data In Signal from MTK DMB Board
37	MTK-CLK	I	Clock Signal from MTK DMB Board
38	FAN CTRL ON/OFF	O	Fan Control Switch "H": fan on
39	METER LED_CTL	O	Dynamic LED drive signal output to the Meter Pointer LED and Meter Backlight LED. "H":LED on (Only for HCD-GTR33 model) Meter pointer LED Control pin. "H":LED on (Only for HCD-GTR55 and HCD-GTR77 model)
40	NO-USE	-	Unused
41	TC REC MUTE	O	TAPE muting control. "H": muting on (Only for African model)
42	MTK PWR CTL	O	Power Control pin for MTK DMB board
43	AD SUPPLY SWITCH	O	AD Power Control pin
44	ST-CLK	O	PLL serial data transfer clock signal output to the tuner unit
45	MTK-OE	O	MTK Output enable control pin
46	NO-USE	-	Unused
47	MTK HUB RST	I	MTK Hub Board reset pin
48	MTK-RESET	I	MTK DMB Board reset pin
49	TC_M+9V SW	O	TCM power supply control signal output "H":power on (Only for African model)
50	PROTECT	I	Speaker protect detection signal input from speaker protect circuit "H":protector on
51	STK MUTE	O	Power amplifier on/off control signal output "H": amplifier on
52	SW SPK RELAY	O	Relay drive signal output for the subwoofer "H":relay on
53	FR SPK RELAY	O	Relay drive signal output for the front speakers "H":relay on

# HCD-GTR33/GTR55/GTR77

Pin No.	Pin Name	I/O	Description
54	STBY RELAY	O	Main power on/off control signal output "H":power on
55	NO-USE	-	Unused
56	NO-USE	-	Unused
57	MTK-VBUS-DET	O	Hub Power (V-DET) Control Port
58	LINE-MUTE	O	Line muting on/off control signal "L":muting on
59	R2A15216FP-CLK	O	Serial data transfer clock signal output to audio signal processor, R2A15216FP
60	R2A15216FP-DATA	O	Serial data output to audio signal processor, R2A15216FP
61	ST-TUNED	I	Tuned detection input from the tuner unit
62	VCC	-	Power supply terminal (+3.3V)
63	ST-CE	O	PLL chip enable signal output to the tuner unit
64	VSS	-	Ground terminal
65	ST-DIN	O	PLL serial data output to the tuner unit
66	MIC/HP_DET	I	Headphone & microphone connection detection signal input (A/D input)
67	ST-DOUT	I	PLL serial data input from the tuner unit
68	MTK-OC1	I	USB Overcurrent Detection input port 1
69	LED CTRL	O	Dynamic LED drive select signal output
70	TC-STATE	I	Tape playback/recording/stop status detection input signal (A/D input) (Only for African model)
71	ILLUMINATOR-INPUT	I	Power illuminator & METER input signal detection (A/D input)
72	METER-IN4	O	Meter motor control signal output 4 (Only for HCD-GTR55 and HCD-GTR77)
73	MTK-OC2	I	USB Overcurrent Detection input port 2
74	POWER/DISPLAY-KEY	I	POWER & DISPLAY key press detection signal (Interrupt input)
75	NO-USE	-	Unused
76	NO-USE	-	Unused
77	METER-IN3	O	Meter motor control signal output 3 (Only for HCD-GTR55 and HCD-GTR77)
78	METER-IN1	O	Meter motor control signal output 1 (Only for HCD-GTR55 and HCD-GTR77)
79	METER-IN2	O	Meter motor control signal output 2 (Only for HCD-GTR55 and HCD-GTR77)
80	USB-B LED	O	Dynamic LED drive signal output to the USB B Blue and Red LED "H":LED on
81	METER SW	I	Min and Max switch input signal from METER (A/D input) (Only for HCD-GTR55 and HCD-GTR77)
82	MTK PWR MON	I	MTK DMB Board power monitor input pin (A/D input)
83	OVERVOLTAGE	I	Over-voltage protection detection input terminal "L": over-voltage detected
84	AD-KEY2	I	Key input terminal (A/D input)
85	MASTER VOL	I	Jog dial pulse input from the MASTER VOLUME encoder (A/D input)
86	LED-VOL1,2	O	Dynamic LED drive signal output to the ILLUMINATION 1st indicator and 2nd indicator "H":LED on
87	AD-KEY1	I	Key input terminal (A/D input)
88	OUTPUT LEVEL DETECT	I	Speaker Output Level Detection
89	VACS-IN	I	VACS level detection signal (A/D input)
90	LED-VOL5,6	O	Dynamic LED drive signal output to the ILLUMINATION 5th indicator and 6th indicator "H":LED on
91	LED-VOL3,4	O	Dynamic LED drive signal output to the ILLUMINATION 3rd indicator and 4th indicator "H":LED on
92	MODEL-IN	I	Model setting terminal (A/D input)
93	DEST-IN	I	Destination setting terminal (A/D input)
94	SW LED/USB A LED	O	Dynamic LED drive signal output to the Subwoofer LED and USB A LED indicator "H":LED on
95	STBY LED	O	LED drive signal output of POWER indicator "H":LED on
96	AVSS	-	Ground terminal (for A/D conversion)
97	AD-KEY0	I	Key input terminal (A/D input)
98	AREF	I	A/D Converter reference voltage input terminal (+3.3V)
99	AVCC	-	Power supply terminal (+3.3V) (for A/D conversion)
100	NO-USE	-	Unused

## SECTION 7 EXPLODED VIEWS

**Note:**

- -XX and -X mean standardized parts, so they may have some difference from the original one.
- Items marked "\*" are not stocked since they are seldom required for routine service. Some delay should be anticipated when ordering these items.
- The mechanical parts with no reference number in the exploded views are not supplied.

- Color Indication of Appearance Parts Example:  
 KNOB, BALANCE (WHITE) . . . (RED)  
↑      ↑  
 Parts Color    Cabinet's Color
- Abbreviation  
 AR : Argentina model  
 E2 : 120V AC area in E model  
 E4 : African model  
 E51 : Chilean and Peruvian models  
 MX : Mexican model

The components identified by mark  $\triangle$  or dotted line with mark  $\triangle$  are critical for safety. Replace only with part number specified.

### 7-1. CASE SECTION

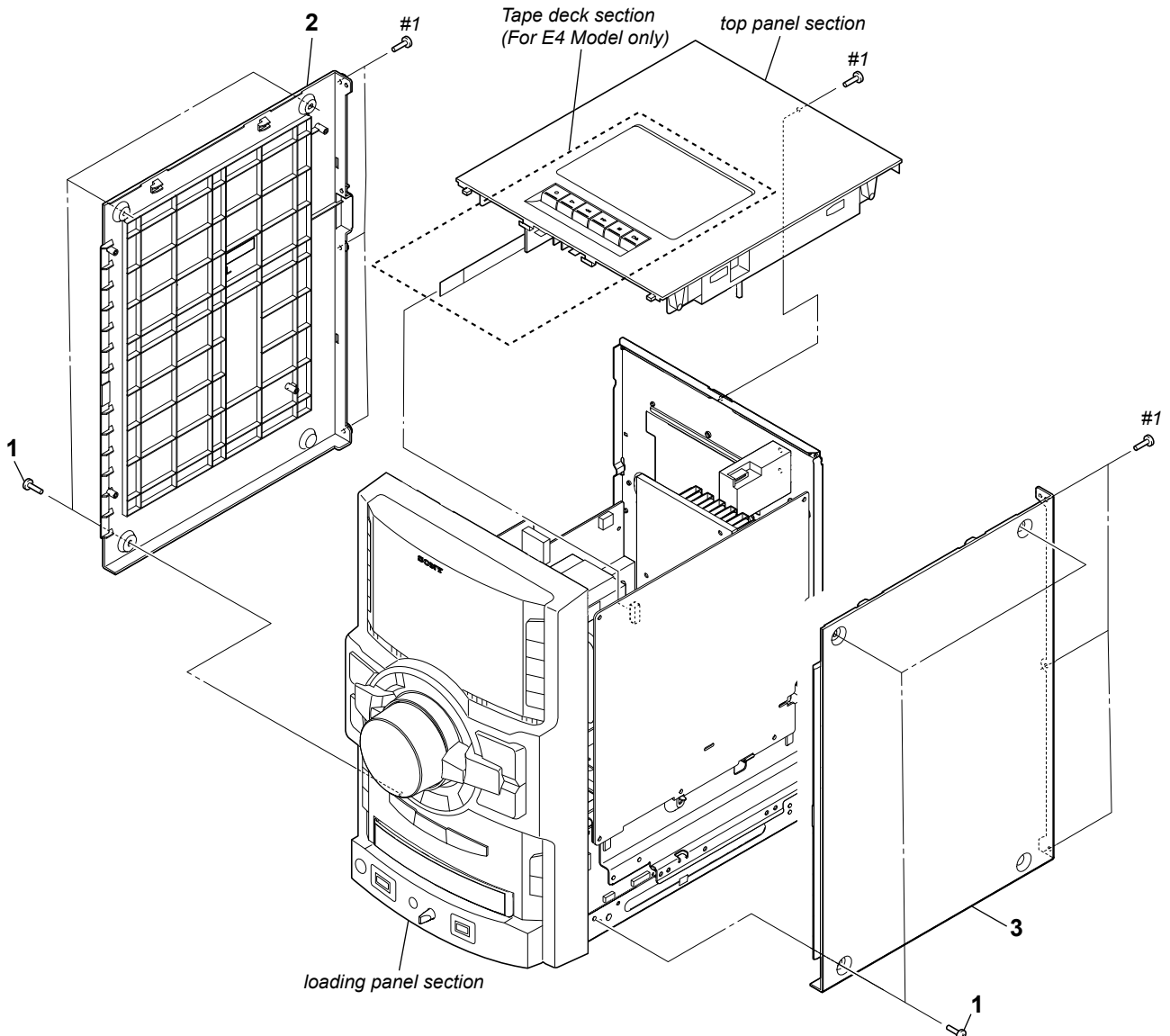

Ref. No.	Part No.	Description	Remark
1	3-363-099-32	SCREW (CASE 3 TP2)	
2	3-283-218-22	CASE, (SIDE-L)	
3	3-283-219-22	CASE, (SIDE-R)	
#1	7-685-646-79	SCREW +BVTP 3X8 TYPE2 IT-3	

7-2. TOP PANEL SECTION

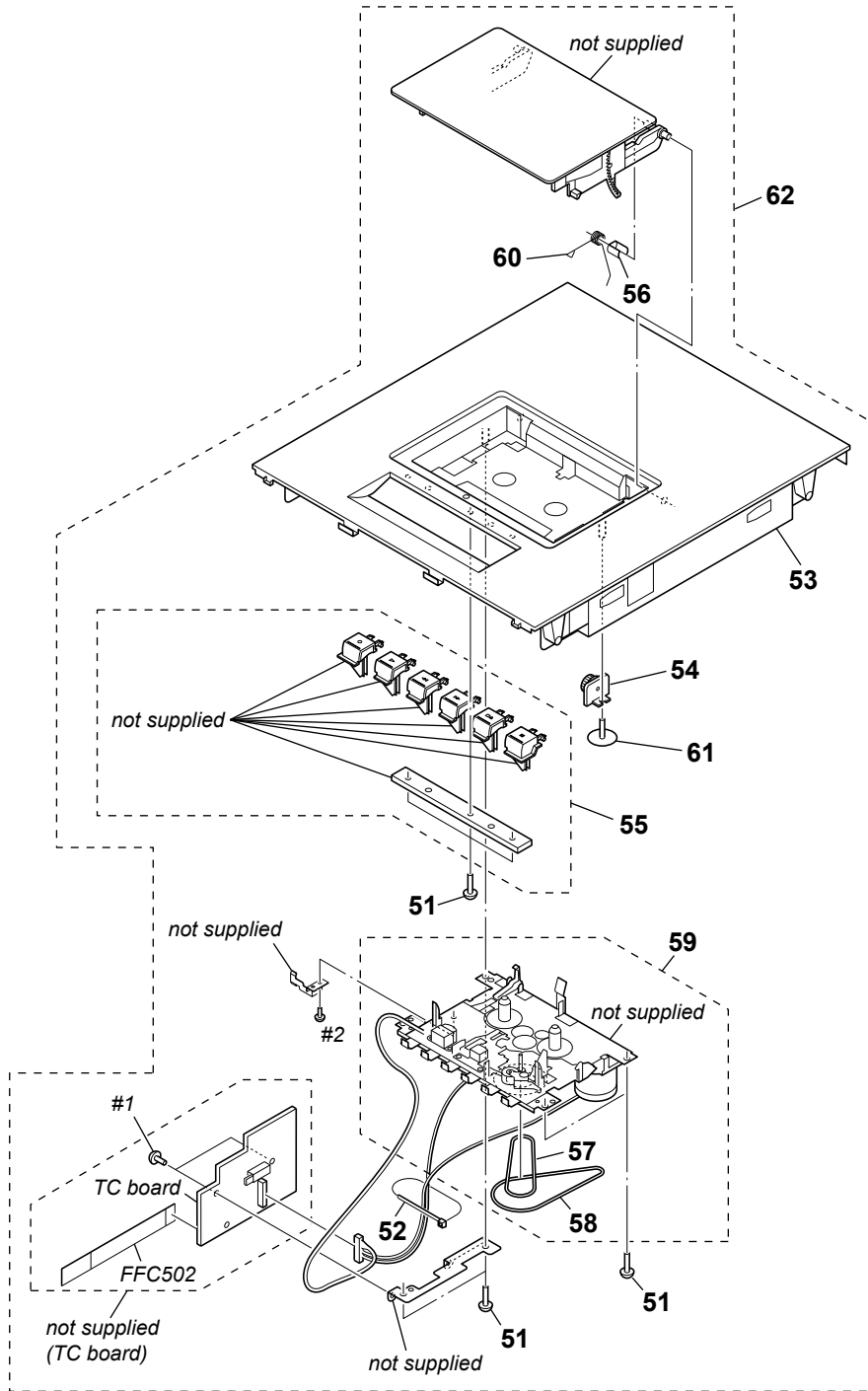

Ref. No.	Part No.	Description	Remark	Ref. No.	Part No.	Description	Remark
51	3-087-053-01	+BVTP2.6 (3CR) (E4)		59	1-797-575-11	DECK, MECHANICAL (E4)	
52	3-701-748-00	CLAMP (E4)		60	4-170-774-01	SPRING (CASS) (E4)	
53	4-124-215-01	CASE, TOP (EXCEPT E4)		61	4-218-252-52	SCREW (+PTPWH M2.6), FLOATING (E4)	
54	3-047-468-01	DAMPER (E4)		62	X-2546-412-1	TOP CASE ASSY (GVX1S/3S/4S) (E4)	
55	2-649-132-21	BUTTON (CASS) (●, ▶, ◀◀, ▶▶, ■▲, ■) (E4)		FFC502	1-828-958-11	WIRE (FLAT TYPE) (9 CORE) (E4)	
56	3-917-753-41	CUSHION (SP) (E4)		#1	7-685-646-79	SCREW +BVTP 3X8 TYPE2 IT-3 (E4)	
57	2-688-621-01	BELT (R/F) (E4)		#2	7-685-850-04	SCREW +BVTT 2X3 (S) (E4)	
58	2-688-622-01	BELT (MAIN) (E4)					



7-3. LOADING PANEL SECTION, HUB BOARD SECTION, DMB19 BOARD SECTION

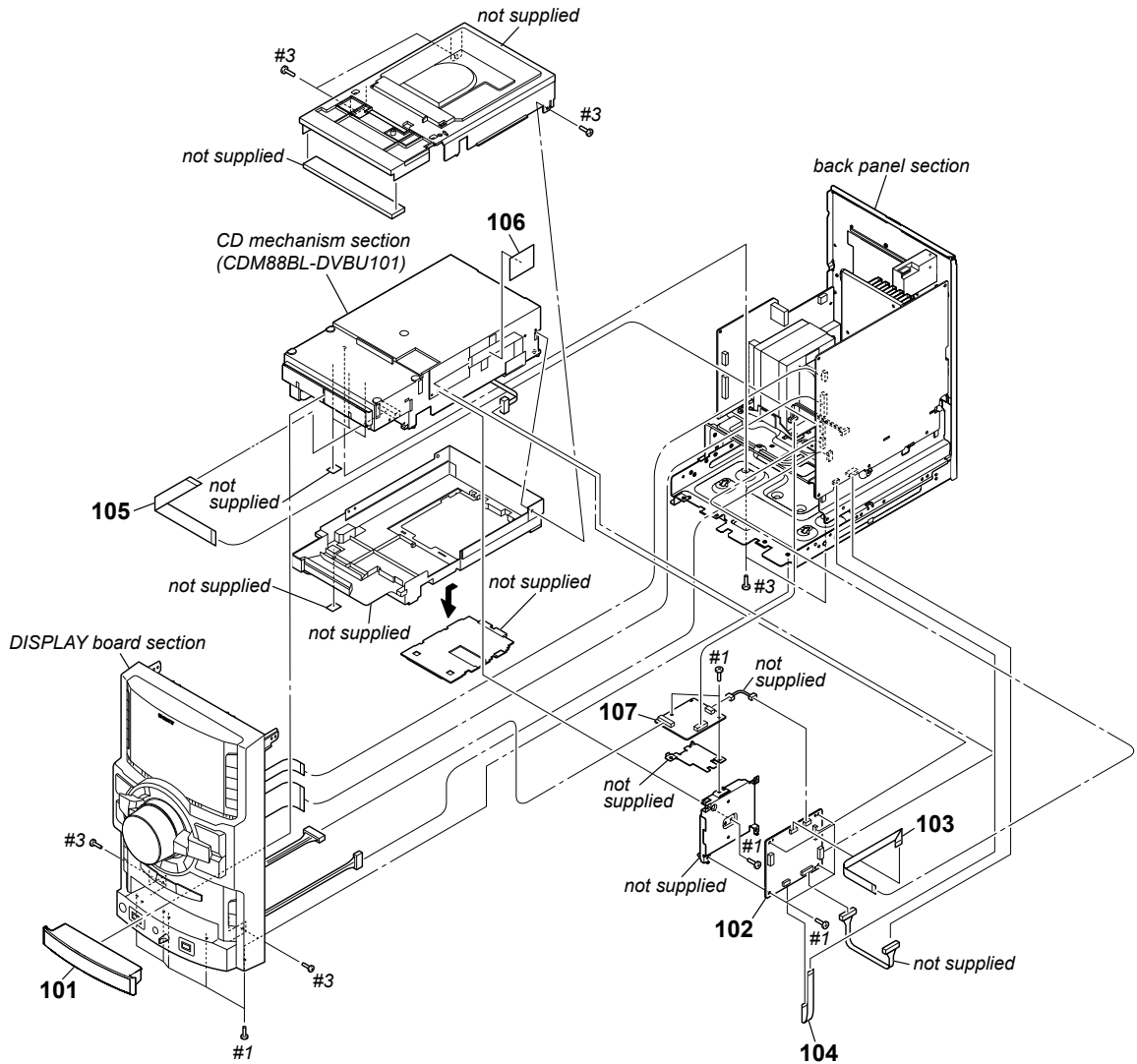

Ref. No.	Part No.	Description	Remark
101	4-164-371-11	PANEL, LOADING	
102	A-1745-142-A	DMB19 BOARD, COMPLETE	
103	1-828-311-51	WIRE (FLAT TYPE) (9 CORE)	
104	1-836-973-11	WIRE (FLAT TYPE) (7 CORE)	
105	1-828-975-11	WIRE (FLAT TYPE) (13 CORE)	
106	3-831-441-11	CUSHION, SARANET	
107	A-1750-170-A	HUB BOARD, COMPLETE	
#1	7-685-646-79	SCREW +BVTP 3X8 TYPE2 IT-3	
#3	7-685-647-79	SCREW +BVTP 3X10 TYPE2 IT-3	

## 7-4. DISPLAY BOARD SECTION

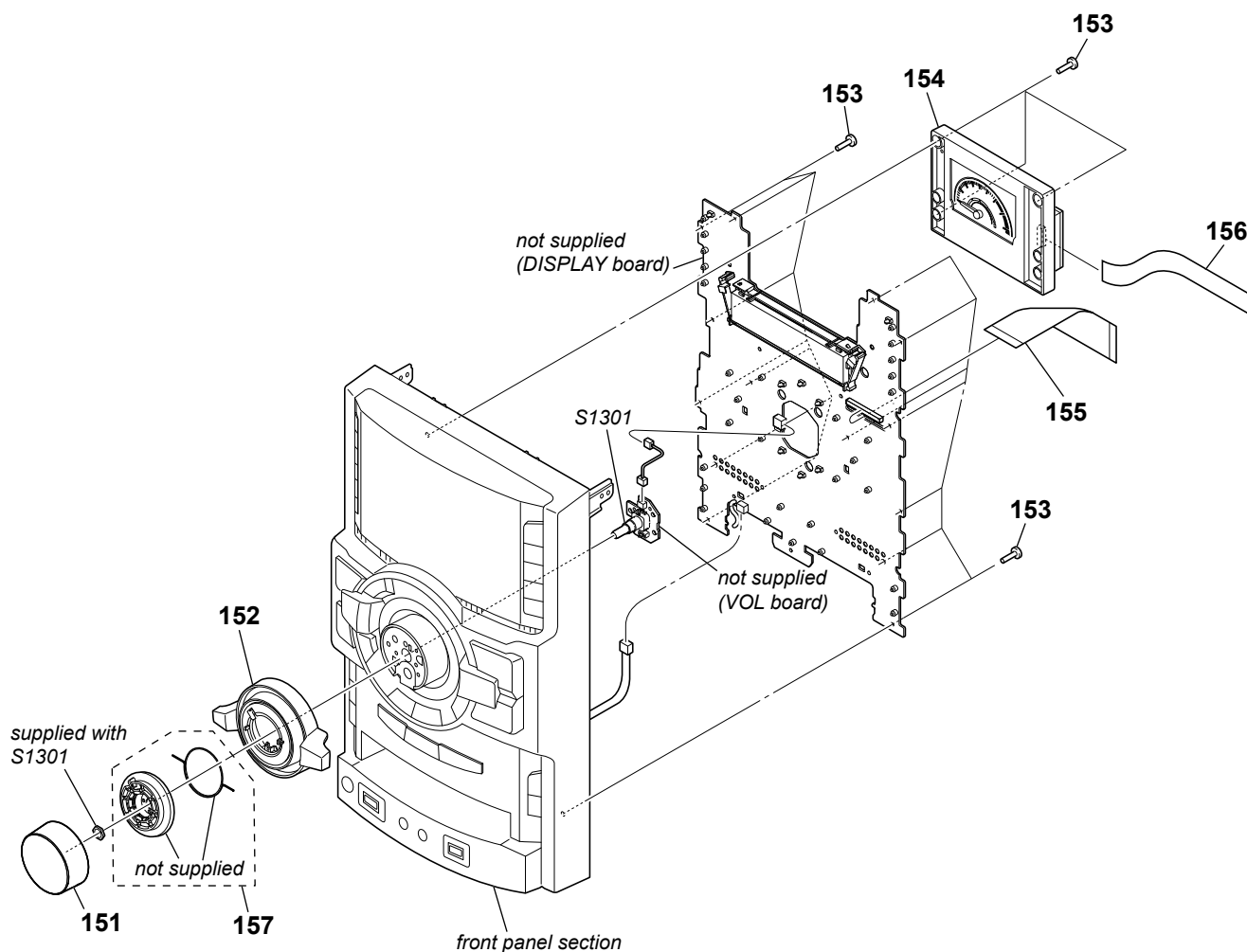

**Note:** If wire (flat type) is replaced, install it after bending it in the same form as that before replacement.

Ref. No.	Part No.	Description	Remark
151	4-164-361-01	KNOB (VOLUME) (GTR33/GTR55)	
151	4-164-361-11	KNOB (VOLUME) (GTR77)	
152	4-164-363-01	KNOB (JOG)	
153	3-087-053-01	+BVTP2.6 (3CR)	
154	A-1754-602-A	METER DISPLAY ASSY (GVX) (GTR55/GTR77)	
154	A-1754-606-A	PANEL (GVX1) ASSY, DISPLAY (GTR33)	
155	1-838-059-11	FLEXIBLE FLAT CABLE (23 CORE)	
156	1-828-964-11	WIRE (FLAT TYPE) (11 CORE) (GTR55/GTR77)	
157	X-2541-975-1	HOLDER (JOG) ASSY	
S1301	1-487-171-11	ROTARY ENCODER	

7-5. FRONT PANEL SECTION

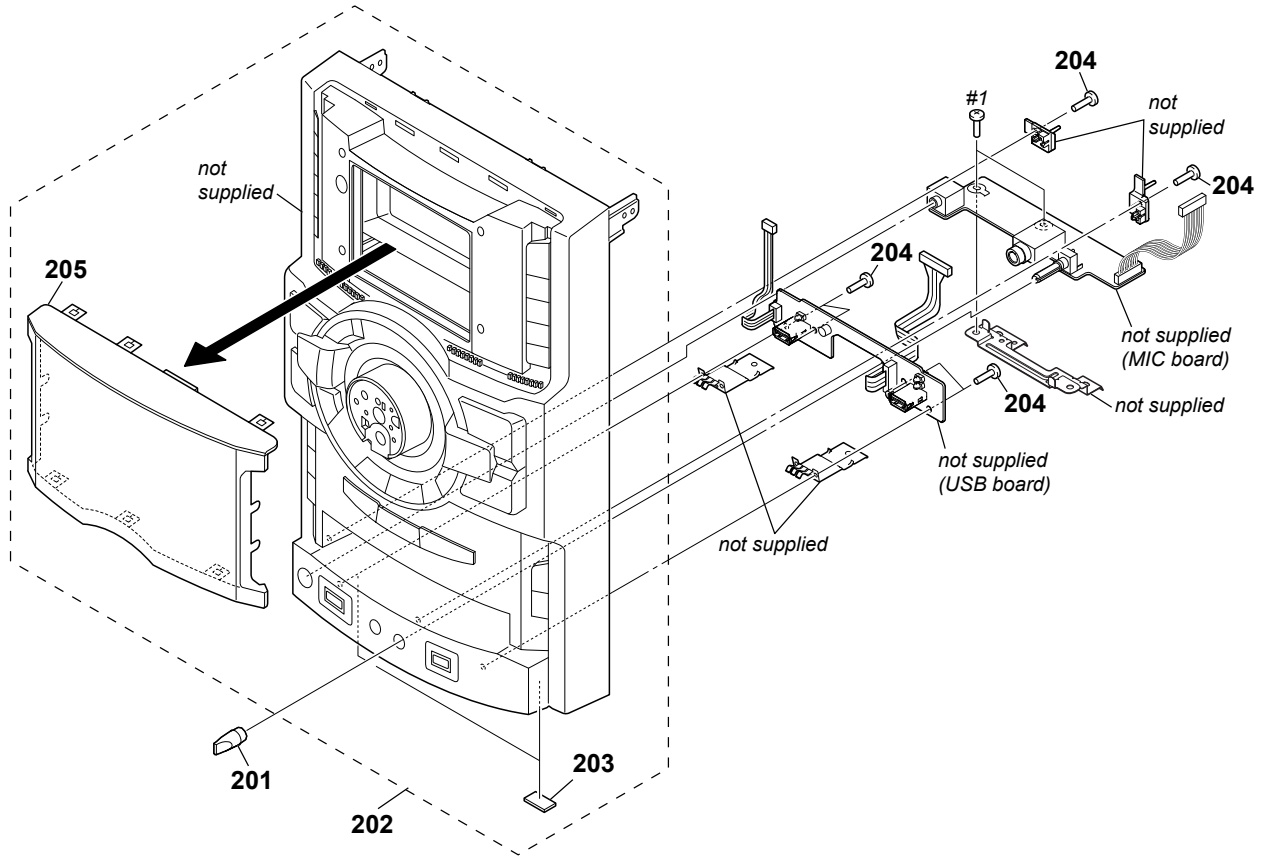

Ref. No.	Part No.	Description	Remark
201	2-895-507-01	KNOB (MIC)	
202	X-2541-955-1	FRONT PANEL ASSY (GVX-COM) (EXCEPT E4)	
202	X-2546-463-1	FRONT PANEL ASSY (GVX-E4) (E4)	
203	4-225-252-01	CUSHION (FOOT)	
204	3-087-053-01	+BVTP2.6 (3CR)	
205	4-164-351-01	WINDOW (FL)	
#1	7-685-646-79	SCREW +BVTP 3X8 TYPE2 IT-3	

## 7-6. BACK PANEL SECTION

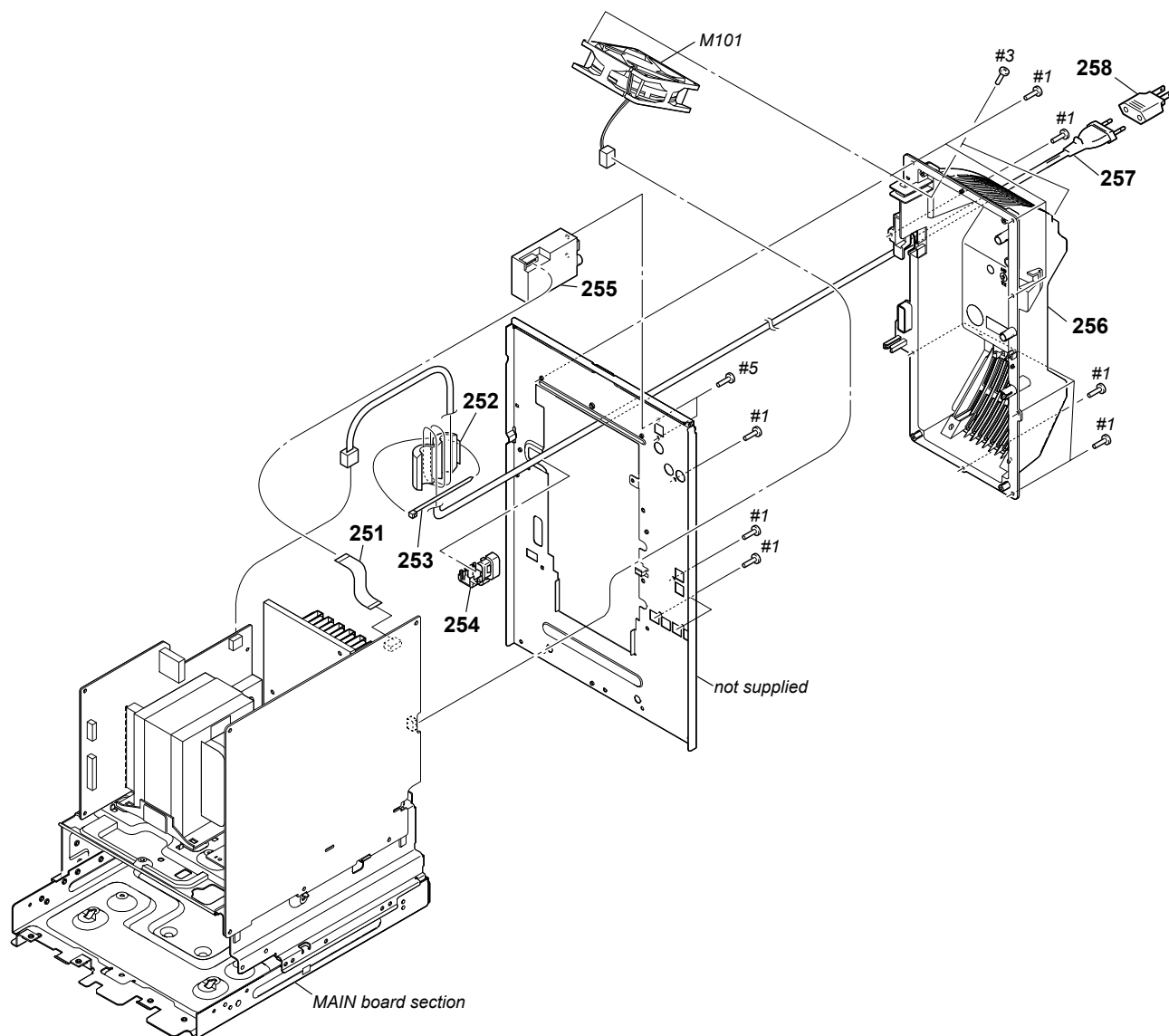

Ref. No.	Part No.	Description	Remark	Ref. No.	Part No.	Description	Remark
251	1-828-952-11	WIRE (FLAT TYPE) (9 CORE)		△ 258	1-569-008-21	ADAPTOR, CONVERSION (E2, E51, E4)	
252	1-457-369-12	CORE, FERRITE		M101	1-787-344-21	FAN, DC	
253	3-655-653-11	BAND (TAITON), BINDING		#1	7-685-646-79	SCREW +BVTP 3X8 TYPE2 IT-3	
254	4-966-267-12	BUSHING (FBS001), CORD		#3	7-685-647-79	SCREW +BVTP 3X10 TYPE2 IT-3	
255	1-693-778-31	TUNER (FM/AM)		#5	7-685-871-01	SCREW +BVTT 3X6 (S)	
256	4-124-216-44	COVER (FAN) (E2, E51, E4)					
256	4-124-216-55	COVER (FAN) (MX, AR)					
△ 257	1-777-071-83	CORD, POWER (E2, E51, E4)					
△ 257	1-837-312-11	CORD, POWER-SUPPLY (AR)					
△ 257	1-837-344-11	CORD, POWER-SUPPLY (MX)					

7-7. MAIN BOARD SECTION

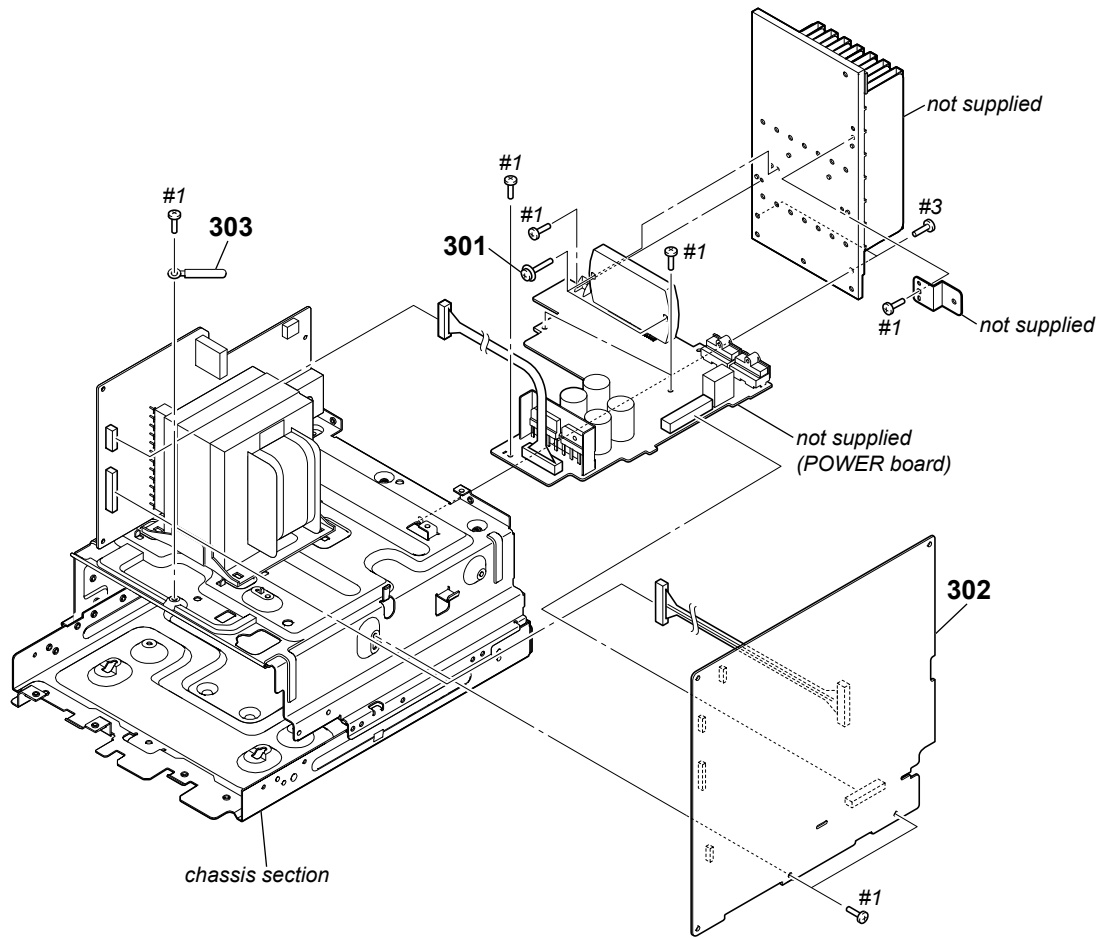

Ref. No.	Part No.	Description	Remark	Ref. No.	Part No.	Description	Remark
301	3-905-609-31	SCREW (TRANSISTOR)		302	A-1754-384-A	MAIN BOARD, COMPLETE (GTR55: E4)	
302	A-1750-177-A	MAIN BOARD, COMPLETE		302	A-1754-390-A	MAIN BOARD, COMPLETE (GTR77: E4)	
		(GTR33: AR, E2, E51, MX)		* 303	3-703-150-11	CLAMP	
302	A-1750-180-A	MAIN BOARD, COMPLETE		#1	7-685-646-79	SCREW +BVTP 3X8 TYPE2 IT-3	
		(GTR55: AR, E2, E51, MX)		#3	7-685-647-79	SCREW +BVTP 3X10 TYPE2 IT-3	
302	A-1750-183-A	MAIN BOARD, COMPLETE					
		(GTR77: AR, E2, E51, MX)					
302	A-1754-378-A	MAIN BOARD, COMPLETE (GTR33: E4)					

## 7-8. CHASSIS SECTION

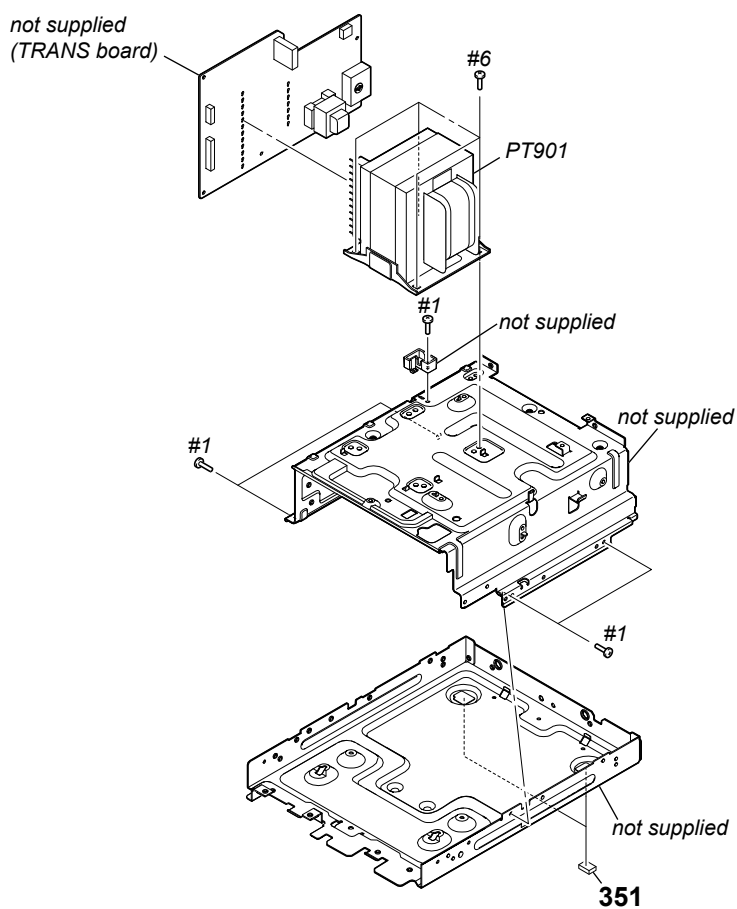

**Note:** If wire (flat type) is replaced, install it after bending it in the same form as that before replacement.

Ref. No.	Part No.	Description	Remark	Ref. No.	Part No.	Description	Remark
	351	4-225-252-01	CUSHION (FOOT)				
△	PT901	1-445-827-11	POWER TRANSFORMER (MAIN) (GTR33:MX)	△	PT901	1-445-835-11	POWER TRANSFORMER (MAIN) (GTR55: E2, E51, AR)
△	PT901	1-445-828-11	POWER TRANSFORMER (MAIN) (GTR33:E4)	△	PT901	1-445-836-11	POWER TRANSFORMER (MAIN) (GTR55:E4)
△	PT901	1-445-829-11	POWER TRANSFORMER (MAIN) (GTR33:E2, E51, AR)	#1	7-685-646-79	SCREW +BVTP 3X8 TYPE2 IT-3	
△	PT901	1-445-830-11	POWER TRANSFORMER (MAIN) (GTR77:MX)	#6	7-685-880-09	SCREW +BVTT 4X6 (S)	
△	PT901	1-445-831-11	POWER TRANSFORMER (MAIN) (GTR77:E4)				
△	PT901	1-445-832-11	POWER TRANSFORMER (MAIN) (GTR77:E2, E5, AR)				
△	PT901	1-445-834-11	POWER TRANSFORMER (MAIN) (GTR55:MX)				



7-9. CD MECHANISM SECTION (CDM88BL-DVBU101)

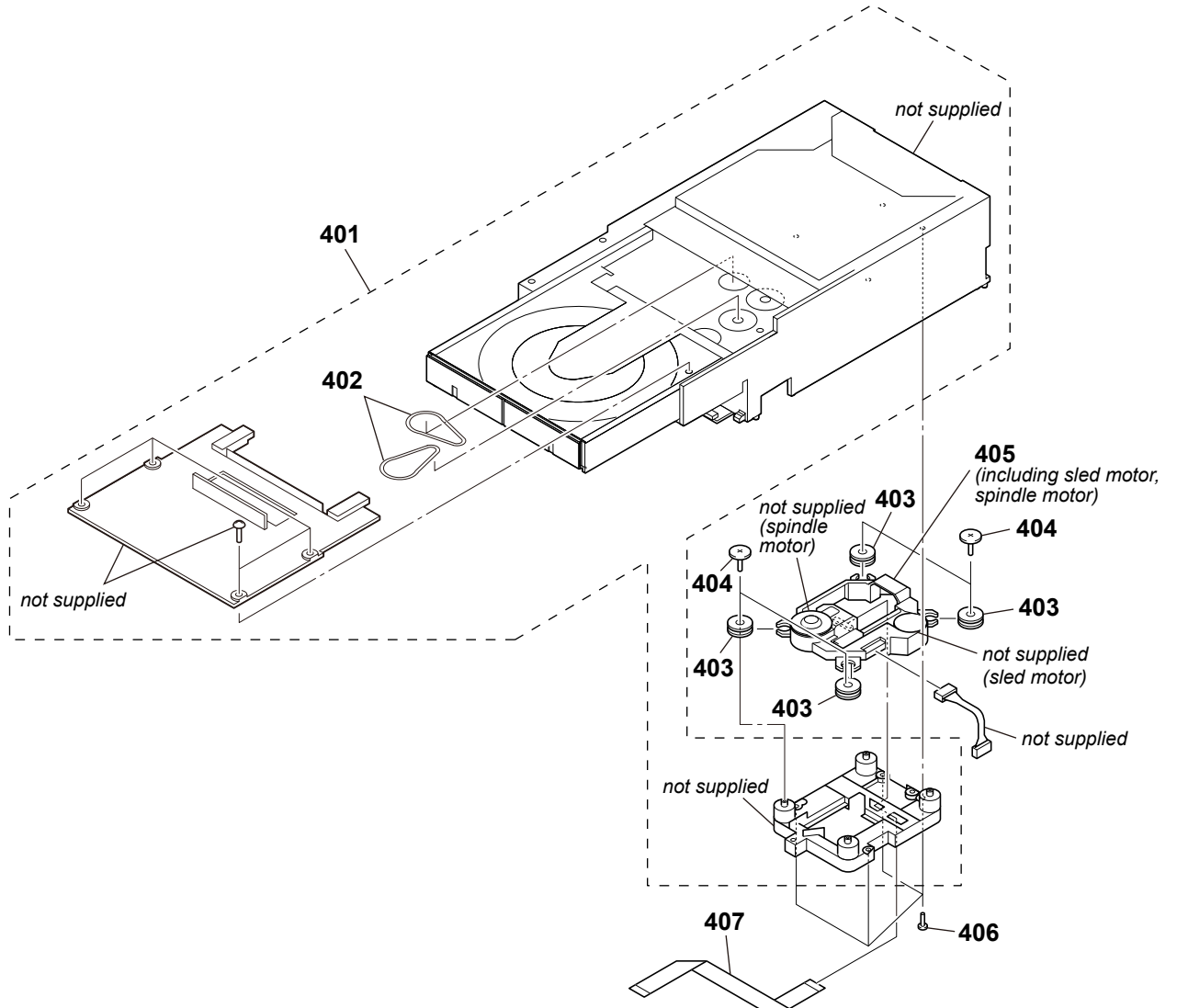

**Note:** If wire (flat type) is replaced, install it after bending it in the same form as that before replacement.

Ref. No.	Part No.	Description	Remark	Ref. No.	Part No.	Description	Remark
401	1-840-387-31	MECHANICAL, CD		406	3-087-053-01	+BVTP2.6 (3CR)	
402	2-632-062-11	BELT (DLM3A)		407	1-828-773-51	WIRE (FLAT TYPE) (24 CORE)	
403	2-634-618-21	INSULATOR					
404	3-087-599-01	INSULATOR SCREW					
△ 405	8-820-322-04	DEVICE, OPTICAL KHM-313CAB/C2NP (Including sled motor, spindle motor)					

**SECTION 8  
ELECTRICAL PARTS LIST**

**DISPLAY**

**Note:**

- Due to standardization, replacements in the parts list may be different from the parts specified in the diagrams or the components used on the set.
- -XX and -X mean standardized parts, so they may have some difference from the original one.
- Items marked "\*" are not stocked since they are seldom required for routine service. Some delay should be anticipated when ordering these items.
- RESISTORS  
All resistors are in ohms.  
METAL: Metal-film resistor.  
METAL OXIDE: Metal oxide-film resistor.  
F: nonflammable

- CAPACITORS  
uF:  $\mu$ F
- COILS  
uH:  $\mu$ H
- SEMICONDUCTORS  
In each case, u:  $\mu$ , for example:  
uA. . . :  $\mu$ A. . . , uPA. . . ,  $\mu$ PA. . . ,  
uPB. . . :  $\mu$ PB. . . , uPC. . . ,  $\mu$ PC. . . ,  
uPD. . . :  $\mu$ PD. . .
- Abbreviation  
AR : Argentine model  
E2 : 120V AC area in E model  
E4 : African model  
E51 : Chilean and Peruvian models  
MX : Mexican model

When indicating parts by reference number, please include the board name.

The components identified by mark  $\triangle$  or dotted line with mark  $\triangle$  are critical for safety.  
Replace only with part number specified.

Ref. No.	Part No.	Description	Remark	Ref. No.	Part No.	Description	Remark
		DISPLAY BOARD *****		JR1008	1-216-295-91	SHORT CHIP	0
				JR1009	1-216-296-11	SHORT CHIP	0
				JR1010	1-216-296-11	SHORT CHIP	0
		< CAPACITOR >		JR1011	1-216-296-11	SHORT CHIP	0
C1136	1-124-257-00	ELECT 2.2uF 20% 50V		JR1012	1-216-296-11	SHORT CHIP	0
C1137	1-124-257-00	ELECT 2.2uF 20% 50V		JR1013	1-216-296-11	SHORT CHIP	0
C1147	1-128-131-11	ELECT 22uF 20% 50V		JR1014	1-216-864-11	SHORT CHIP	0
C1150	1-164-156-11	CERAMIC CHIP 0.1uF 25V		JR1015	1-216-296-11	SHORT CHIP	0
C1151	1-162-927-11	CERAMIC CHIP 100PF 5% 50V		JR1016	1-216-296-11	SHORT CHIP	0
C1152	1-162-927-11	CERAMIC CHIP 100PF 5% 50V		JR1017	1-216-296-11	SHORT CHIP	0
C1153	1-162-927-11	CERAMIC CHIP 100PF 5% 50V		JR1018	1-216-296-11	SHORT CHIP	0
C1155	1-126-947-11	ELECT 47uF 20% 35V		JR1019	1-216-296-11	SHORT CHIP	0
C1156	1-164-156-11	CERAMIC CHIP 0.1uF 25V		JR1020	1-216-296-11	SHORT CHIP	0
		< CONNECTOR >		JR1021	1-216-296-11	SHORT CHIP	0
CN1102	1-564-720-11	PIN, CONNECTOR (SMALL TYPE) 4P		JR1022	1-216-296-11	SHORT CHIP	0
CN1103	1-564-719-11	PIN, CONNECTOR (SMALL TYPE) 3P		JR1023	1-216-864-11	SHORT CHIP	0
CN1105	1-784-784-11	CONNECTOR, FFC 23P		JR1024	1-216-296-11	SHORT CHIP	0
		< DIODE >		JR1025	1-216-296-11	SHORT CHIP	0
D1101	6-502-469-01	DI SLI-325URT31WR		JR1026	1-216-296-11	SHORT CHIP	0
D1102	6-501-752-01	DIODE MAZ8082GMLS0		JR1027	1-216-296-11	SHORT CHIP	0
D1104	8-719-060-27	DIODE SLR-325MCT31		JR1028	1-216-296-11	SHORT CHIP	0
D1105	6-503-224-01	DI 1L0351V22F0MIT01		JR1029	1-216-296-11	SHORT CHIP	0
D1106	6-503-224-01	DI 1L0351V22F0MIT01		JR1030	1-216-296-11	SHORT CHIP	0
D1107	6-503-224-01	DI 1L0351V22F0MIT01		JR1031	1-216-296-11	SHORT CHIP	0
D1108	6-503-224-01	DI 1L0351V22F0MIT01		JR1032	1-216-296-11	SHORT CHIP	0
D1109	6-503-224-01	DI 1L0351V22F0MIT01		JR1033	1-216-296-11	SHORT CHIP	0
D1110	6-503-224-01	DI 1L0351V22F0MIT01		JR1034	1-216-296-11	SHORT CHIP	0
		< FLUORESCENT INDICATOR TUBE >		JR1035	1-216-864-11	SHORT CHIP	0
FL1100	1-483-077-11	VACUUM FLUORESCENT DISPLAYS		JR1036	1-216-864-11	SHORT CHIP	0
		< IC >				< TRANSISTOR >	
IC1100	6-600-768-01	IC PNA4823M03S0		Q1118	8-729-620-07	TRANSISTOR 2SC3052EF-T1-LEF	
IC1101	6-713-680-01	IC PT6324-Q		Q1119	8-729-620-07	TRANSISTOR 2SC3052EF-T1-LEF	
		< JUMPER RESISTOR >		Q1120	8-729-620-07	TRANSISTOR 2SC3052EF-T1-LEF	
JR1001	1-216-295-91	SHORT CHIP 0		Q1121	8-729-620-07	TRANSISTOR 2SC3052EF-T1-LEF	
JR1002	1-216-864-11	SHORT CHIP 0		Q1122	8-729-620-07	TRANSISTOR 2SC3052EF-T1-LEF	
JR1003	1-216-295-91	SHORT CHIP 0				< RESISTOR >	
JR1004	1-216-296-11	SHORT CHIP 0		R1100	1-216-819-11	METAL CHIP 680 5% 1/10W	
JR1005	1-216-296-11	SHORT CHIP 0		R1101	1-216-821-11	METAL CHIP 1K 5% 1/10W	
JR1006	1-216-296-11	SHORT CHIP 0		R1102	1-216-823-11	METAL CHIP 1.5K 5% 1/10W	
JR1007	1-216-296-11	SHORT CHIP 0		R1103	1-216-823-11	METAL CHIP 1.5K 5% 1/10W	
				R1104	1-216-825-11	METAL CHIP 2.2K 5% 1/10W	
				R1105	1-216-827-11	METAL CHIP 3.3K 5% 1/10W	
				R1106	1-216-829-11	METAL CHIP 4.7K 5% 1/10W	

Ref. No.	Part No.	Description	Remark	Ref. No.	Part No.	Description	Remark
R1107	1-218-867-11	METAL CHIP 6.8K	0.5%	1/10W	S1118	1-771-410-21	SWITCH, TACTILE (TUNER/BAND)
R1108	1-216-833-11	METAL CHIP 10K	5%	1/10W	S1119	1-771-410-21	SWITCH, TACTILE (TAPE /PC)
R1113	1-216-819-11	METAL CHIP 680	5%	1/10W			
R1114	1-216-821-11	METAL CHIP 1K	5%	1/10W	S1124	1-771-410-21	SWITCH, TACTILE (USB A)
R1115	1-216-823-11	METAL CHIP 1.5K	5%	1/10W	S1125	1-771-410-21	SWITCH, TACTILE (RETURN)
R1116	1-216-823-11	METAL CHIP 1.5K	5%	1/10W	S1126	1-771-410-21	SWITCH, TACTILE (REC TO USB B)
R1117	1-216-825-11	METAL CHIP 2.2K	5%	1/10W	S1127	1-771-410-21	SWITCH, TACTILE (ENTER)
R1118	1-216-827-11	METAL CHIP 3.3K	5%	1/10W	S1128	1-771-410-21	SWITCH, TACTILE (USB B)
R1119	1-216-829-11	METAL CHIP 4.7K	5%	1/10W	S1129	1-771-410-21	SWITCH, TACTILE (DISC 1)
R1120	1-218-867-11	METAL CHIP 6.8K	0.5%	1/10W	S1130	1-771-410-21	SWITCH, TACTILE (DISC 2)
R1121	1-216-833-11	METAL CHIP 10K	5%	1/10W	S1131	1-771-410-21	SWITCH, TACTILE (DISC 3)
R1158	1-216-841-11	METAL CHIP 47K	5%	1/10W	S1132	1-771-410-21	SWITCH, TACTILE (▲ OPEN/CLOSE)
R1160	1-216-841-11	METAL CHIP 47K	5%	1/10W	S1133	1-771-410-21	SWITCH, TACTILE (DISC SKIP/EX-CHANGE)
					*****		
R1161	1-216-821-11	METAL CHIP 1K	5%	1/10W	A-1745-142-A	DMB19 BOARD, COMPLETE	
R1162	1-216-819-11	METAL CHIP 680	5%	1/10W		*****	
R1163	1-216-821-11	METAL CHIP 1K	5%	1/10W			
R1164	1-216-823-11	METAL CHIP 1.5K	5%	1/10W		< CAPACITOR >	
R1165	1-216-823-11	METAL CHIP 1.5K	5%	1/10W			
R1166	1-216-825-11	METAL CHIP 2.2K	5%	1/10W	C101	1-162-970-11	CERAMIC CHIP 0.01uF 10% 25V
R1167	1-216-827-11	METAL CHIP 3.3K	5%	1/10W	C102	1-107-826-11	CERAMIC CHIP 0.1uF 10% 16V
R1168	1-216-829-11	METAL CHIP 4.7K	5%	1/10W	C105	1-128-994-21	ELECT CHIP 47uF 20% 10V
R1169	1-218-867-11	METAL CHIP 6.8K	0.5%	1/10W	C106	1-162-970-11	CERAMIC CHIP 0.01uF 10% 25V
R1170	1-216-833-11	METAL CHIP 10K	5%	1/10W	C108	1-162-965-11	CERAMIC CHIP 0.0015uF 10% 50V
R1171	1-216-833-11	METAL CHIP 10K	5%	1/10W	C111	1-107-826-11	CERAMIC CHIP 0.1uF 10% 16V
R1173	1-216-821-11	METAL CHIP 1K	5%	1/10W	C112	1-128-994-21	ELECT CHIP 47uF 20% 10V
R1174	1-216-821-11	METAL CHIP 1K	5%	1/10W	C113	1-162-970-11	CERAMIC CHIP 0.01uF 10% 25V
R1189	1-216-819-11	METAL CHIP 680	5%	1/10W	C115	1-107-826-11	CERAMIC CHIP 0.1uF 10% 16V
R1190	1-216-819-11	METAL CHIP 680	5%	1/10W	C116	1-107-826-11	CERAMIC CHIP 0.1uF 10% 16V
R1195	1-216-819-11	METAL CHIP 680	5%	1/10W	C118	1-124-779-00	ELECT CHIP 10uF 20% 16V
R1196	1-216-819-11	METAL CHIP 680	5%	1/10W	C119	1-137-710-91	CERAMIC CHIP 10uF 20% 6.3V
R1198	1-216-819-11	METAL CHIP 680	5%	1/10W	C124	1-165-908-11	CERAMIC CHIP 1uF 10% 10V
R1199	1-216-819-11	METAL CHIP 680	5%	1/10W	C125	1-107-826-11	CERAMIC CHIP 0.1uF 10% 16V
R1201	1-216-833-11	METAL CHIP 10K	5%	1/10W	C126	1-137-710-91	CERAMIC CHIP 10uF 20% 6.3V
R1203	1-216-833-11	METAL CHIP 10K	5%	1/10W	C127	1-165-908-11	CERAMIC CHIP 1uF 10% 10V
R1205	1-216-833-11	METAL CHIP 10K	5%	1/10W	C144	1-162-970-11	CERAMIC CHIP 0.01uF 10% 25V
R1207	1-216-833-11	METAL CHIP 10K	5%	1/10W	C145	1-162-970-11	CERAMIC CHIP 0.01uF 10% 25V
R1209	1-216-809-11	METAL CHIP 100	5%	1/10W	C146	1-165-908-11	CERAMIC CHIP 1uF 10% 10V
R1210	1-216-809-11	METAL CHIP 100	5%	1/10W	C149	1-162-970-11	CERAMIC CHIP 0.01uF 10% 25V
R1211	1-216-809-11	METAL CHIP 100	5%	1/10W	C150	1-162-970-11	CERAMIC CHIP 0.01uF 10% 25V
R1215	1-216-845-11	METAL CHIP 100K	5%	1/10W	C151	1-162-970-11	CERAMIC CHIP 0.01uF 10% 25V
		< SWITCH >			C152	1-162-916-11	CERAMIC CHIP 12PF 5% 50V
S1100	1-771-410-21	SWITCH, TACTILE (II) (STANDBY)			C153	1-162-916-11	CERAMIC CHIP 12PF 5% 50V
S1101	1-771-410-21	SWITCH, TACTILE (DISPLAY)			C154	1-107-826-11	CERAMIC CHIP 0.1uF 10% 16V
S1102	1-771-410-21	SWITCH, TACTILE (METER MODE)			C155	1-107-826-11	CERAMIC CHIP 0.1uF 10% 16V
S1103	1-771-410-21	SWITCH, TACTILE (OPTIONS)			C156	1-162-970-11	CERAMIC CHIP 0.01uF 10% 25V
S1104	1-771-410-21	SWITCH, TACTILE (ERASE)			C160	1-162-970-11	CERAMIC CHIP 0.01uF 10% 25V
S1105	1-771-410-21	SWITCH, TACTILE (EQ BAND/SURROUND)			C168	1-107-826-11	CERAMIC CHIP 0.1uF 10% 16V
S1106	1-771-410-21	SWITCH, TACTILE (GROOVE)			C169	1-107-826-11	CERAMIC CHIP 0.1uF 10% 16V
S1107	1-771-410-21	SWITCH, TACTILE (PRESET EQ)			C172	1-162-970-11	CERAMIC CHIP 0.01uF 10% 25V
S1108	1-771-410-21	SWITCH, TACTILE (REC TIMER)			C175	1-162-970-11	CERAMIC CHIP 0.01uF 10% 25V
S1109	1-771-410-21	SWITCH, TACTILE (SUBWOOFER)			C179	1-107-826-11	CERAMIC CHIP 0.1uF 10% 16V
S1110	1-771-410-21	SWITCH, TACTILE (CD)			C180	1-107-826-11	CERAMIC CHIP 0.1uF 10% 16V
S1111	1-771-410-21	SWITCH, TACTILE (CD)			C181	1-107-826-11	CERAMIC CHIP 0.1uF 10% 16V
S1112	1-771-410-21	SWITCH, TACTILE (II)			C183	1-165-908-11	CERAMIC CHIP 1uF 10% 10V
S1113	1-771-410-21	SWITCH, TACTILE (TUNING -)			C188	1-164-315-11	CERAMIC CHIP 470PF 5% 50V
S1114	1-771-410-21	SWITCH, TACTILE (USB)			C190	1-128-995-21	ELECT CHIP 100uF 20% 10V
S1115	1-771-410-21	SWITCH, TACTILE (TUNING +)			C191	1-107-826-11	CERAMIC CHIP 0.1uF 10% 16V
S1116	1-771-410-21	SWITCH, TACTILE (TUNING +)			C192	1-162-970-11	CERAMIC CHIP 0.01uF 10% 25V
S1117	1-771-410-21	SWITCH, TACTILE (TUNING +)			C193	1-127-715-11	CERAMIC CHIP 0.22uF 10% 16V
					C195	1-127-715-11	CERAMIC CHIP 0.22uF 10% 16V
					C197	1-107-826-11	CERAMIC CHIP 0.1uF 10% 16V

# HCD-GTR33/GTR55/GTR77

## DMB19

Ref. No.	Part No.	Description	Remark	Ref. No.	Part No.	Description	Remark
C198	1-165-908-11	CERAMIC CHIP 1uF 10%	10V			< DIODE >	
C199	1-162-968-11	CERAMIC CHIP 0.0047uF 10%	50V				
C203	1-162-970-11	CERAMIC CHIP 0.01uF 10%	25V	D001	6-500-848-01	DIODE MC2840-T112-1	
C205	1-164-230-11	CERAMIC CHIP 220PF 5%	50V	D002	6-500-848-01	DIODE MC2840-T112-1	
C206	1-164-230-11	CERAMIC CHIP 220PF 5%	50V	D003	6-500-848-01	DIODE MC2840-T112-1	
C208	1-162-970-11	CERAMIC CHIP 0.01uF 10%	25V	D004	6-500-848-01	DIODE MC2840-T112-1	
C209	1-164-677-11	CERAMIC CHIP 0.033uF 10%	16V	D005	6-500-848-01	DIODE MC2840-T112-1	
						< EARTH TERMINAL >	
C210	1-162-970-11	CERAMIC CHIP 0.01uF 10%	25V	ET001	1-780-482-11	EARTH TERMINAL	
C211	1-164-677-11	CERAMIC CHIP 0.033uF 10%	16V	ET002	1-780-482-11	EARTH TERMINAL	
C212	1-162-970-11	CERAMIC CHIP 0.01uF 10%	25V	ET003	1-780-482-11	EARTH TERMINAL	
C213	1-162-970-11	CERAMIC CHIP 0.01uF 10%	25V	ET004	1-780-482-11	EARTH TERMINAL	
C214	1-162-964-11	CERAMIC CHIP 0.001uF 10%	50V			< FERRITE BEAD >	
C215	1-162-970-11	CERAMIC CHIP 0.01uF 10%	25V				
C216	1-162-970-11	CERAMIC CHIP 0.01uF 10%	25V	FB108	1-469-324-21	FERRITE, EMI (SMD) (2012)	
C217	1-117-681-11	ELECT CHIP 100uF 20%	16V	FB603	1-469-324-21	FERRITE, EMI (SMD) (2012)	
C218	1-128-994-21	ELECT CHIP 47uF 20%	10V	FB607	1-469-324-21	FERRITE, EMI (SMD) (2012)	
C219	1-162-970-11	CERAMIC CHIP 0.01uF 10%	25V	FB1264	1-469-118-21	FERRITE, EMI (SMD) (1608)	
C220	1-128-994-21	ELECT CHIP 47uF 20%	10V	FB1265	1-469-118-21	FERRITE, EMI (SMD) (1608)	
C221	1-164-360-11	CERAMIC CHIP 0.1uF	16V				
C222	1-164-360-11	CERAMIC CHIP 0.1uF	16V	FB1266	1-469-118-21	FERRITE, EMI (SMD) (1608)	
C224	1-162-970-11	CERAMIC CHIP 0.01uF 10%	25V	FB1267	1-469-118-21	FERRITE, EMI (SMD) (1608)	
C233	1-162-968-11	CERAMIC CHIP 0.0047uF 10%	50V	FB1268	1-469-118-21	FERRITE, EMI (SMD) (1608)	
C502	1-125-891-11	CERAMIC CHIP 0.47uF 10%	10V			< FLUORESCENT INDICATOR TUBE >	
C602	1-128-995-21	ELECT CHIP 100uF 20%	10V	FL603	1-234-494-21	FILTER, EMI REMOVAL (SMD)	
C603	1-128-995-21	ELECT CHIP 100uF 20%	10V			< IC >	
C604	1-128-995-21	ELECT CHIP 100uF 20%	10V				
C608	1-107-826-11	CERAMIC CHIP 0.1uF 10%	16V	IC101	6-714-821-01	IC CXD9968R (LE)	
C611	1-100-566-91	CERAMIC CHIP 0.1uF 10%	25V	IC102	(Not supplied)	IC MX25L1605DM2I-12G	
C620	1-164-360-11	CERAMIC CHIP 0.1uF	16V	IC104	6-714-642-01	IC EM638165 TSA-6G	
C621	1-164-360-11	CERAMIC CHIP 0.1uF	16V	IC107	6-702-302-01	IC TK11133CSCL-G	
C622	1-164-360-11	CERAMIC CHIP 0.1uF	16V	IC111	6-706-838-01	IC MM1661JHBE	
C623	1-164-360-11	CERAMIC CHIP 0.1uF	16V				
C1504	1-162-960-11	CERAMIC CHIP 220PF 10%	50V	IC201	6-704-524-01	IC FAN8036L	
C1505	1-162-970-11	CERAMIC CHIP 0.01uF 10%	25V	IC4601	6-710-554-01	IC PCM1808PWR	
C1506	1-162-964-11	CERAMIC CHIP 0.001uF 10%	50V	IC4602	6-704-819-01	IC CS4335-KSZR	
C1507	1-107-826-11	CERAMIC CHIP 0.1uF 10%	16V			< TRANSISTOR >	
C1512	1-107-826-11	CERAMIC CHIP 0.1uF 10%	16V				
C1513	1-107-826-11	CERAMIC CHIP 0.1uF 10%	16V	Q101	6-550-008-01	TRANSISTOR UM6K1N-TN	
C1514	1-162-919-11	CERAMIC CHIP 22PF 5%	50V	Q102	6-550-653-01	TRANSISTOR QST8TR	
C1515	1-162-919-11	CERAMIC CHIP 22PF 5%	50V	Q103	8-729-027-52	TRANSISTOR DTC124EKA-T146	
C1516	1-162-919-11	CERAMIC CHIP 22PF 5%	50V			< RESISTOR >	
C4602	1-164-360-11	CERAMIC CHIP 0.1uF	16V				
C4603	1-164-360-11	CERAMIC CHIP 0.1uF	16V	R101	1-216-809-11	METAL CHIP 100 5% 1/10W	
C4606	1-164-360-11	CERAMIC CHIP 0.1uF	16V	R102	1-216-864-11	SHORT CHIP 0	
C4608	1-124-779-00	ELECT CHIP 10uF 20%	16V	R103	1-218-864-11	METAL CHIP 5.1K 0.5% 1/10W	
C4622	1-162-927-11	CERAMIC CHIP 100PF 5%	50V	R107	1-216-833-11	METAL CHIP 10K 5% 1/10W	
C4623	1-162-927-11	CERAMIC CHIP 100PF 5%	50V	R108	1-216-857-11	METAL CHIP 1M 5% 1/10W	
C4626	1-162-970-11	CERAMIC CHIP 0.01uF 10%	25V	R109	1-216-809-11	METAL CHIP 100 5% 1/10W	
		< CONNECTOR >		R110	1-216-841-11	METAL CHIP 47K 5% 1/10W	
CN101	1-815-763-32	CONNECTOR, FFC/FPC 24P		R111	1-216-809-11	METAL CHIP 100 5% 1/10W	
CN105	1-770-470-21	PIN, CONNECTOR (PC BOARD) 6P		R112	1-211-977-11	METAL CHIP 22 0.5% 1/10W	
CN201	1-770-161-21	PIN, CONNECTOR (PC BOARD) 6P		R113	1-211-977-11	METAL CHIP 22 0.5% 1/10W	
CN601	1-778-795-21	PIN, CONNECTOR (PC BOARD) 9P		R114	1-216-845-11	METAL CHIP 100K 5% 1/10W	
* CN1105	1-750-005-11	PIN, CONNECTOR (PC BOARD) 4P		R115	1-211-977-11	METAL CHIP 22 0.5% 1/10W	
CN1106	1-784-861-51	CONNECTOR, FFC (LIF (NON-ZIF)) 9P		R116	1-216-821-11	METAL CHIP 1K 5% 1/10W	
CN4602	1-784-859-51	CONNECTOR, FFC (LIF (NON-ZIF)) 7P		R117	1-216-841-11	METAL CHIP 47K 5% 1/10W	
				R118	1-216-801-11	METAL CHIP 22 5% 1/10W	

**Note:** When IC102 cannot exchange with single. When this part is damaged, exchange the entire mounted board.

Ref. No.	Part No.	Description	Remark	Ref. No.	Part No.	Description	Remark
R120	1-216-801-11	METAL CHIP	22 5%	1/10W	R1249	1-216-821-11	METAL CHIP 1K 5% 1/10W
R121	1-216-801-11	METAL CHIP	22 5%	1/10W	R1250	1-216-295-91	SHORT CHIP 0
R122	1-216-833-11	METAL CHIP	10K 5%	1/10W	R1252	1-216-295-91	SHORT CHIP 0
R123	1-216-809-11	METAL CHIP	100 5%	1/10W	R1255	1-216-295-91	SHORT CHIP 0
R124	1-216-841-11	METAL CHIP	47K 5%	1/10W	R1256	1-216-295-91	SHORT CHIP 0
R125	1-216-833-11	METAL CHIP	10K 5%	1/10W	R1261	1-216-833-11	METAL CHIP 10K 5% 1/10W
R133	1-216-864-11	SHORT CHIP	0		R1262	1-216-833-11	METAL CHIP 10K 5% 1/10W
R136	1-216-835-11	METAL CHIP	15K 5%	1/10W	R1263	1-216-864-11	SHORT CHIP 0
R142	1-216-845-11	METAL CHIP	100K 5%	1/10W	R1269	1-216-809-11	METAL CHIP 100 5% 1/10W
R156	1-216-809-11	METAL CHIP	100 5%	1/10W	R1276	1-216-864-11	SHORT CHIP 0
R204	1-216-822-11	METAL CHIP	1.2K 5%	1/10W	R1277	1-216-809-11	METAL CHIP 100 5% 1/10W
R205	1-216-833-11	METAL CHIP	10K 5%	1/10W	R1278	1-216-833-11	METAL CHIP 10K 5% 1/10W
R206	1-216-833-11	METAL CHIP	10K 5%	1/10W	R1279	1-216-833-11	METAL CHIP 10K 5% 1/10W
R207	1-216-826-11	METAL CHIP	2.7K 5%	1/10W	R1280	1-216-864-11	SHORT CHIP 0
R208	1-216-839-11	METAL CHIP	33K 5%	1/10W	R1281	1-216-864-11	SHORT CHIP 0
R209	1-216-839-11	METAL CHIP	33K 5%	1/10W	R1282	1-216-864-11	SHORT CHIP 0
R210	1-216-841-11	METAL CHIP	47K 5%	1/10W	R1283	1-216-864-11	SHORT CHIP 0
R212	1-216-833-11	METAL CHIP	10K 5%	1/10W	R4601	1-216-809-11	METAL CHIP 100 5% 1/10W
R213	1-218-867-11	METAL CHIP	6.8K 0.5%	1/10W	R4602	1-216-809-11	METAL CHIP 100 5% 1/10W
R214	1-216-835-11	METAL CHIP	15K 5%	1/10W	R4605	1-469-112-11	FERRITE, EMI (SMD) (1608)
R215	1-216-834-11	METAL CHIP	12K 5%	1/10W	R4606	1-216-801-11	METAL CHIP 22 5% 1/10W
R216	1-216-834-11	METAL CHIP	12K 5%	1/10W	R4608	1-216-864-11	SHORT CHIP 0
R219	1-216-838-11	METAL CHIP	27K 5%	1/10W	R4609	1-216-864-11	SHORT CHIP 0
R220	1-216-821-11	METAL CHIP	1K 5%	1/10W	R4611	1-216-864-11	SHORT CHIP 0
R221	1-218-889-11	METAL CHIP	56K 0.5%	1/10W	R4833	1-216-864-11	SHORT CHIP 0
R223	1-218-895-11	METAL CHIP	100K 0.5%	1/10W	R4834	1-216-864-11	SHORT CHIP 0
R224	1-216-833-11	METAL CHIP	10K 5%	1/10W	R4835	1-216-295-91	SHORT CHIP 0
R225	1-218-895-11	METAL CHIP	100K 0.5%	1/10W	R4837	1-216-864-11	SHORT CHIP 0
R226	1-218-889-11	METAL CHIP	56K 0.5%	1/10W	R4838	1-216-864-11	SHORT CHIP 0
R230	1-218-893-11	METAL CHIP	82K 0.5%	1/10W	< COMPOSITION CIRCUIT BLOCK >		
R231	1-218-875-11	METAL CHIP	15K 0.5%	1/10W	RB105	1-234-400-21	CONDUCTOR, NETWORK (1005X4)
R232	1-218-877-11	METAL CHIP	18K 0.5%	1/10W	RB106	1-234-400-21	CONDUCTOR, NETWORK (1005X4)
R233	1-218-883-11	METAL CHIP	33K 0.5%	1/10W	RB107	1-234-400-21	CONDUCTOR, NETWORK (1005X4)
R234	1-216-833-11	METAL CHIP	10K 5%	1/10W	RB108	1-234-400-21	CONDUCTOR, NETWORK (1005X4)
R246	1-216-829-11	METAL CHIP	4.7K 5%	1/10W	RB111	1-234-400-21	CONDUCTOR, NETWORK (1005X4)
R247	1-216-821-11	METAL CHIP	1K 5%	1/10W	RB112	1-234-400-21	CONDUCTOR, NETWORK (1005X4)
R256	1-216-833-11	METAL CHIP	10K 5%	1/10W	RB113	1-234-400-21	CONDUCTOR, NETWORK (1005X4)
R521	1-216-833-11	METAL CHIP	10K 5%	1/10W	RB114	1-234-400-21	CONDUCTOR, NETWORK (1005X4)
R605	1-216-295-91	SHORT CHIP	0		RB115	1-234-400-21	CONDUCTOR, NETWORK (1005X4)
R606	1-216-295-91	SHORT CHIP	0		< VIBRATOR >		
R608	1-216-295-91	SHORT CHIP	0		X101	1-814-103-21	VIBRATOR, CRYSTAL (27MHz)
R630	1-216-295-91	SHORT CHIP	0		*****		
R1101	1-218-841-11	METAL CHIP	560 0.5%	1/10W	A-1750-170-A HUB BOARD, COMPLETE		
R1110	1-216-826-11	METAL CHIP	2.7K 5%	1/10W	*****		
R1114	1-500-903-21	EMI FERRITE (SMD)			< CAPACITOR >		
R1121	1-216-864-11	SHORT CHIP	0		C1500	1-100-597-91	CERAMIC CHIP 0.1uF 10% 25V
R1123	1-216-864-11	SHORT CHIP	0		C1501	1-165-989-11	CERAMIC CHIP 10uF 10% 6.3V
R1129	1-216-845-11	METAL CHIP	100K 5%	1/10W	C1502	1-100-597-91	CERAMIC CHIP 0.1uF 10% 25V
R1150	1-216-827-11	METAL CHIP	3.3K 5%	1/10W	C1503	1-162-915-11	CERAMIC CHIP 10PF 0.5PF 50V
R1151	1-216-827-11	METAL CHIP	3.3K 5%	1/10W	C1504	1-162-919-11	CERAMIC CHIP 22PF 5% 50V
R1152	1-216-827-11	METAL CHIP	3.3K 5%	1/10W	C1505	1-162-970-11	CERAMIC CHIP 0.01uF 10% 25V
R1168	1-218-835-11	METAL CHIP	330 0.5%	1/10W	C1506	1-162-970-11	CERAMIC CHIP 0.01uF 10% 25V
R1177	1-216-864-11	SHORT CHIP	0		C1507	1-100-597-91	CERAMIC CHIP 0.1uF 10% 25V
R1178	1-216-821-11	METAL CHIP	1K 5%	1/10W	C1508	1-165-989-11	CERAMIC CHIP 10uF 10% 6.3V
R1184	1-216-809-11	METAL CHIP	100 5%	1/10W	C1510	1-100-597-91	CERAMIC CHIP 0.1uF 10% 25V
R1191	1-216-864-11	SHORT CHIP	0		C1511	1-162-970-11	CERAMIC CHIP 0.01uF 10% 25V
R1192	1-216-864-11	SHORT CHIP	0		C1512	1-165-989-11	CERAMIC CHIP 10uF 10% 6.3V
R1193	1-216-864-11	SHORT CHIP	0				
R1194	1-216-864-11	SHORT CHIP	0				
R1248	1-216-295-91	SHORT CHIP	0				



# HCD-GTR33/GTR55/GTR77

**HUB**   **MAIN**

Ref. No.	Part No.	Description	Remark
C1513	1-162-970-11	CERAMIC CHIP 0.01uF 10%	25V
C1514	1-165-989-11	CERAMIC CHIP 10uF 10%	6.3V
C1515	1-162-970-11	CERAMIC CHIP 0.01uF 10%	25V
C1516	1-162-970-11	CERAMIC CHIP 0.01uF 10%	25V
C1517	1-100-597-91	CERAMIC CHIP 0.1uF 10%	25V
C1518	1-100-597-91	CERAMIC CHIP 0.1uF 10%	25V
C1519	1-162-970-11	CERAMIC CHIP 0.01uF 10%	25V
C1520	1-137-765-21	ELECT CHIP 47uF 20%	16V
C1521	1-162-964-11	CERAMIC CHIP 0.001uF 10%	50V
C1522	1-100-597-91	CERAMIC CHIP 0.1uF 10%	25V
C1523	1-100-597-91	CERAMIC CHIP 0.1uF 10%	25V
C1524	1-100-597-91	CERAMIC CHIP 0.1uF 10%	25V
C1527	1-100-597-91	CERAMIC CHIP 0.1uF 10%	25V
C1528	1-100-597-91	CERAMIC CHIP 0.1uF 10%	25V
C1529	1-100-597-91	CERAMIC CHIP 0.1uF 10%	25V
C1530	1-162-910-11	CERAMIC CHIP 5PF 0.25PF	50V
C1531	1-162-910-11	CERAMIC CHIP 5PF 0.25PF	50V
< CONNECTOR >			
CN1500	1-774-731-21	PIN, CONNECTOR (PC BOARD) 5P	
CN1501	1-774-729-21	PIN, CONNECTOR (PC BOARD) 10P	
CN1502	1-785-728-21	PIN (PC BOARD), CONNECTOR 7P	
< EARTH TERMINAL >			
* ET1500	1-780-408-11	TERMINAL, LUG	
* ET1501	1-780-408-11	TERMINAL, LUG	
< FERRITE BEAD >			
* FB1500	1-400-973-21	INDUCTOR (EMI FERRITE)	
FB1501	1-216-295-91	SHORT CHIP 0	
* FB1502	1-400-973-21	INDUCTOR (EMI FERRITE)	
FB1503	1-216-295-91	SHORT CHIP 0	
* FB1505	1-400-973-21	INDUCTOR (EMI FERRITE)	
< IC >			
IC1500	8-759-338-95	IC NJM2903V (TE2)	
IC1501	6-714-034-01	IC USB2512A-AEZG	
< RESISTOR >			
R1500	1-216-809-11	METAL CHIP 100 5%	1/10W
R1501	1-216-837-11	METAL CHIP 22K 5%	1/10W
R1503	1-216-815-11	METAL CHIP 330 5%	1/10W
R1504	1-218-446-11	METAL CHIP 1 5%	1/10W
R1505	1-218-446-11	METAL CHIP 1 5%	1/10W
R1506	1-218-446-11	METAL CHIP 1 5%	1/10W
R1507	1-218-446-11	METAL CHIP 1 5%	1/10W
R1508	1-218-446-11	METAL CHIP 1 5%	1/10W
R1509	1-218-446-11	METAL CHIP 1 5%	1/10W
R1510	1-218-446-11	METAL CHIP 1 5%	1/10W
R1511	1-218-446-11	METAL CHIP 1 5%	1/10W
R1512	1-218-446-11	METAL CHIP 1 5%	1/10W
R1513	1-218-446-11	METAL CHIP 1 5%	1/10W
R1515	1-216-837-11	METAL CHIP 22K 5%	1/10W
R1516	1-216-815-11	METAL CHIP 330 5%	1/10W
R1517	1-218-446-11	METAL CHIP 1 5%	1/10W
R1518	1-218-446-11	METAL CHIP 1 5%	1/10W
R1519	1-218-446-11	METAL CHIP 1 5%	1/10W
R1520	1-218-446-11	METAL CHIP 1 5%	1/10W
R1521	1-218-446-11	METAL CHIP 1 5%	1/10W

Ref. No.	Part No.	Description	Remark
R1522	1-218-446-11	METAL CHIP 1 5%	1/10W
R1523	1-218-446-11	METAL CHIP 1 5%	1/10W
R1524	1-218-446-11	METAL CHIP 1 5%	1/10W
R1525	1-218-446-11	METAL CHIP 1 5%	1/10W
R1526	1-218-446-11	METAL CHIP 1 5%	1/10W
R1527	1-216-809-11	METAL CHIP 100 5%	1/10W
R1530	1-216-857-11	METAL CHIP 1M 5%	1/10W
R1533	1-216-845-11	METAL CHIP 100K 5%	1/10W
R1537	1-216-845-11	METAL CHIP 100K 5%	1/10W
R1538	1-216-845-11	METAL CHIP 100K 5%	1/10W
R1540	1-216-845-11	METAL CHIP 100K 5%	1/10W
R1541	1-216-809-11	METAL CHIP 100 5%	1/10W
R1542	1-216-845-11	METAL CHIP 100K 5%	1/10W
R1543	1-216-833-11	METAL CHIP 10K 5%	1/10W
R1544	1-216-833-11	METAL CHIP 10K 5%	1/10W
R1546	1-216-809-11	METAL CHIP 100 5%	1/10W
R1547	1-216-834-11	METAL CHIP 12K 5%	1/10W
< VIBRATOR >			
X1500	1-760-613-21	VIBRATOR, CRYSTAL (24MHz)	
*****			
A-1750-177-A	MAIN BOARD, COMPLETE (GTR33: E2, E51, MX, AR)		
A-1750-180-A	MAIN BOARD, COMPLETE (GTR55: E2, E51, MX, AR)		
A-1750-183-A	MAIN BOARD, COMPLETE (GTR77: E2, E51, MX, AR)		
A-1754-378-A	MAIN BOARD, COMPLETE (GTR33: E4)		
A-1754-384-A	MAIN BOARD, COMPLETE (GTR55: E4)		
A-1754-390-A	MAIN BOARD, COMPLETE (GTR77: E4)		
*****			
7-685-646-79	SCREW +BVTP 3X8 TYPE2 IT-3		
< CAPACITOR >			
C102	1-126-963-11	ELECT 4.7uF 20%	50V
C109	1-126-964-11	ELECT 10uF 20%	50V
C110	1-162-953-11	CERAMIC CHIP 100PF 5%	50V
C111	1-162-953-11	CERAMIC CHIP 100PF 5%	50V
C112	1-162-962-11	CERAMIC CHIP 470PF 10%	50V
C115	1-162-919-11	CERAMIC CHIP 22PF 5%	50V
C116	1-162-919-11	CERAMIC CHIP 22PF 5%	50V
C118	1-126-961-11	ELECT 2.2uF 20%	50V
C120	1-100-385-91	CERAMIC CHIP 0.47uF	25V
C123	1-126-964-11	ELECT 10uF 20%	50V
C124	1-126-960-11	ELECT 1uF 20%	50V
C125	1-162-962-11	CERAMIC CHIP 470PF 10%	50V
C127	1-137-190-91	FILM 0.22uF 5%	50V
C127	1-136-171-00	FILM 0.33uF 5%	50V (GTR33)
C128	1-136-498-81	FILM 0.12uF 5%	50V (GTR55/GTR77)
C128	1-137-189-11	FILM 0.18uF 5%	50V (GTR33)
C129	1-126-961-11	ELECT 2.2uF 20%	50V
C131	1-126-964-11	ELECT 10uF 20%	50V
C132	1-136-161-00	FILM 0.047uF 5%	50V
C133	1-164-227-11	CERAMIC CHIP 0.022uF 10%	25V
C134	1-162-970-11	CERAMIC CHIP 0.01uF 10%	25V
C135	1-162-970-11	CERAMIC CHIP 0.01uF 10%	25V
C137	1-126-964-11	ELECT 10uF 20%	50V



Ref. No.	Part No.	Description	Remark	Ref. No.	Part No.	Description	Remark	
C139	1-135-834-91	CERAMIC CHIP	2.2E+06PF	6.3V	C275	1-162-964-11	CERAMIC CHIP	0.001uF 10% 50V
C142	1-117-720-11	CERAMIC CHIP	4.7uF	10V	C277	1-126-964-11	ELECT	10uF 20% 50V
C143	1-117-720-11	CERAMIC CHIP	4.7uF	10V	C278	1-115-339-11	CERAMIC CHIP	0.1uF 10% 50V
C144	1-126-964-11	ELECT	10uF	20% 50V	C281	1-162-913-11	CERAMIC CHIP	8PF 0.5PF 50V
C145	1-117-720-11	CERAMIC CHIP	4.7uF	10V	C284	1-104-658-91	ELECT	100uF 20% 10V
C146	1-117-720-11	CERAMIC CHIP	4.7uF	10V	C285	1-162-964-11	CERAMIC CHIP	0.001uF 10% 50V
C147	1-126-959-11	ELECT	0.47uF	20% 50V	C286	1-126-935-11	ELECT	470uF 20% 16V
C148	1-104-658-91	ELECT	100uF	20% 10V	C287	1-126-964-11	ELECT	10uF 20% 50V
C149	1-104-658-91	ELECT	100uF	20% 10V	C288	1-126-960-11	ELECT	1uF 20% 50V
C150	1-100-597-91	CERAMIC CHIP	0.1uF	10% 25V	C290	1-136-164-00	FILM	0.082uF 5% 50V
C151	1-100-597-91	CERAMIC CHIP	0.1uF	10% 25V	C292	1-137-194-81	FILM	0.47uF 5% 50V
C152	1-100-756-91	CERAMIC CHIP	0.047uF	10% 50V				(GTR55)
C153	1-100-597-91	CERAMIC CHIP	0.1uF	10% 25V	C292	1-136-176-00	FILM	0.82uF 5% 50V
C154	1-126-935-11	ELECT	470uF	20% 16V				(GTR33)
C160	1-162-923-11	CERAMIC CHIP	47PF	5% 50V	C292	1-137-198-81	FILM	1uF 5% 50V
C161	1-162-962-11	CERAMIC CHIP	470PF	10% 50V				(GTR77)
C162	1-162-962-11	CERAMIC CHIP	470PF	10% 50V	C293	1-100-717-91	CERAMIC CHIP	1uF 16V
C163	1-162-923-11	CERAMIC CHIP	47PF	5% 50V	C321	1-162-963-11	CERAMIC CHIP	680PF 10% 50V
C164	1-162-962-11	CERAMIC CHIP	470PF	10% 50V	C322	1-100-597-91	CERAMIC CHIP	0.1uF 10% 25V
C165	1-162-962-11	CERAMIC CHIP	470PF	10% 50V	C380	1-136-162-00	FILM	0.056uF 5% 50V
C177	1-136-498-81	FILM	0.12uF	5% 50V				(GTR77)
					C380	1-136-495-11	FILM	0.068uF 5% 50V
								(GTR33/GTR55)
C177	1-137-189-11	FILM	0.18uF	5% 50V	C382	1-136-162-00	FILM	0.056uF 5% 50V
								(GTR33)
C178	1-137-190-91	FILM	0.22uF	5% 50V	C382	1-136-495-11	FILM	0.068uF 5% 50V
								(GTR55/GTR77)
C178	1-136-171-00	FILM	0.33uF	5% 50V				(GTR33)
					C383	1-137-189-11	FILM	0.18uF 5% 50V
					C390	1-115-339-11	CERAMIC CHIP	0.1uF 10% 50V
					C410	1-162-918-11	CERAMIC CHIP	18PF 5% 50V
C179	1-126-961-11	ELECT	2.2uF	20% 50V	C411	1-162-920-11	CERAMIC CHIP	27PF 5% 50V
C180	1-126-960-11	ELECT	1uF	20% 50V	C414	1-100-597-91	CERAMIC CHIP	0.1uF 10% 25V
C181	1-126-964-11	ELECT	10uF	20% 50V				
C182	1-136-161-00	FILM	0.047uF	5% 50V	C417	1-126-917-11	ELECT	3300uF 20% 6.3V
C183	1-162-970-11	CERAMIC CHIP	0.01uF	10% 25V	C422	1-165-176-11	CERAMIC CHIP	0.047uF 10% 16V
C184	1-164-227-11	CERAMIC CHIP	0.022uF	10% 25V	C423	1-165-176-11	CERAMIC CHIP	0.047uF 10% 16V
C185	1-162-970-11	CERAMIC CHIP	0.01uF	10% 25V	C424	1-165-176-11	CERAMIC CHIP	0.047uF 10% 16V
C187	1-126-964-11	ELECT	10uF	20% 50V	C425	1-165-176-11	CERAMIC CHIP	0.047uF 10% 16V
C192	1-117-720-11	CERAMIC CHIP	4.7uF	10V	C426	1-165-176-11	CERAMIC CHIP	0.047uF 10% 16V
C193	1-117-720-11	CERAMIC CHIP	4.7uF	10V	C427	1-165-176-11	CERAMIC CHIP	0.047uF 10% 16V
C194	1-126-964-11	ELECT	10uF	20% 50V	C428	1-165-176-11	CERAMIC CHIP	0.047uF 10% 16V
C195	1-117-720-11	CERAMIC CHIP	4.7uF	10V	C431	1-162-962-11	CERAMIC CHIP	470PF 10% 50V
C201	1-126-961-11	ELECT	2.2uF	20% 50V	C432	1-162-962-11	CERAMIC CHIP	470PF 10% 50V
C211	1-126-964-11	ELECT	10uF	20% 50V	C434	1-162-923-11	CERAMIC CHIP	47PF 5% 50V
C212	1-164-156-11	CERAMIC CHIP	0.1uF	25V	C437	1-162-923-11	CERAMIC CHIP	47PF 5% 50V
C213	1-126-964-11	ELECT	10uF	20% 50V	C438	1-162-923-11	CERAMIC CHIP	47PF 5% 50V
C214	1-128-934-11	CERAMIC CHIP	0.33uF	20% 10V	C439	1-162-923-11	CERAMIC CHIP	47PF 5% 50V
C215	1-126-964-11	ELECT	10uF	20% 50V	C440	1-162-923-11	CERAMIC CHIP	47PF 5% 50V
C219	1-107-826-11	CERAMIC CHIP	0.1uF	10% 16V	C464	1-100-597-91	CERAMIC CHIP	0.1uF 10% 25V
C220	1-126-947-11	ELECT	47uF	20% 35V	C483	1-162-964-11	CERAMIC CHIP	0.001uF 10% 50V
C222	1-162-923-11	CERAMIC CHIP	47PF	5% 50V	C496	1-100-597-91	CERAMIC CHIP	0.1uF 10% 25V
C223	1-162-919-11	CERAMIC CHIP	22PF	5% 50V	C498	1-126-964-11	ELECT	10uF 20% 50V
C224	1-126-964-11	ELECT	10uF	20% 50V	C499	1-100-597-91	CERAMIC CHIP	0.1uF 10% 25V
C225	1-126-934-11	ELECT	220uF	20% 16V	C500	1-126-964-11	ELECT	10uF 20% 50V
C227	1-126-964-11	ELECT	10uF	20% 50V	C550	1-162-919-11	CERAMIC CHIP	22PF 5% 50V
C232	1-162-964-11	CERAMIC CHIP	0.001uF	10% 50V	C552	1-162-919-11	CERAMIC CHIP	22PF 5% 50V
C233	1-162-964-11	CERAMIC CHIP	0.001uF	10% 50V	C553	1-162-919-11	CERAMIC CHIP	22PF 5% 50V
C242	1-162-962-11	CERAMIC CHIP	470PF	10% 50V	C554	1-162-919-11	CERAMIC CHIP	22PF 5% 50V
C243	1-100-717-91	CERAMIC CHIP	1uF	16V	C555	1-162-919-11	CERAMIC CHIP	22PF 5% 50V
C270	1-126-947-11	ELECT	47uF	20% 35V	C556	1-162-919-11	CERAMIC CHIP	22PF 5% 50V
C272	1-162-923-11	CERAMIC CHIP	47PF	5% 50V	C602	1-126-944-11	ELECT	3300uF 20% 25V
C273	1-162-919-11	CERAMIC CHIP	22PF	5% 50V	C604	1-136-497-81	FILM	0.1uF 5% 50V
C274	1-126-964-11	ELECT	10uF	20% 50V	C605	1-136-497-81	FILM	0.1uF 5% 50V

# HCD-GTR33/GTR55/GTR77

## MAIN

Ref. No.	Part No.	Description	Remark	Ref. No.	Part No.	Description	Remark
C608	1-100-597-91	CERAMIC CHIP	0.1uF 10% 25V	D621	6-502-272-01	DI RB055L-40TE25	
C609	1-126-933-11	ELECT	100uF 20% 16V	D623	6-500-522-21	DIODE 10EDB40-TB3	
C610	1-100-597-91	CERAMIC CHIP	0.1uF 10% 25V	D624	6-500-522-21	DIODE 10EDB40-TB3	
C611	1-104-658-91	ELECT	100uF 20% 10V	D628	6-501-817-01	DIODE MA2J1110GLS0	
C612	1-100-597-91	CERAMIC CHIP	0.1uF 10% 25V	D630	6-501-817-01	DIODE MA2J1110GLS0	
C616	1-126-936-11	ELECT	3300uF 20% 16V	D650	6-501-713-01	DIODE MAZ8033G0LS0	
C617	1-136-497-81	FILM	0.1uF 5% 50V	D651	6-500-522-21	DIODE 10EDB40-TB3	
C618	1-136-497-81	FILM	0.1uF 5% 50V	D652	6-500-522-21	DIODE 10EDB40-TB3	
C620	1-135-372-31	ELECT	470uF 20% 10V	D653	6-500-522-21	DIODE 10EDB40-TB3	
C621	1-128-953-31	ELECT	470uF 20% 25V	D691	6-501-817-01	DIODE MA2J1110GLS0	
C624	1-165-728-31	ELECT	330uF 20% 16V	D692	6-501-734-01	DIODE MAZ8056GMLS0	
C625	1-126-951-11	ELECT	470uF 20% 35V	D694	6-501-817-01	DIODE MA2J1110GLS0	
C654	1-162-966-11	CERAMIC CHIP	0.0022uF 10% 50V	D696	6-501-734-01	DIODE MAZ8056GMLS0	(GTR55/GTR77)
C655	1-126-923-91	ELECT	220uF 20% 10V	D699	6-500-335-01	DIODE MC2838-T112-1	
C656	1-164-156-11	CERAMIC CHIP	0.1uF 25V			< IC >	
C660	1-126-964-11	ELECT	10uF 20% 50V	IC252	8-759-278-58	IC NJM4558V-TE2	
			(GTR55/GTR77)	IC253	8-759-278-58	IC NJM4558V-TE2	
C692	1-100-597-91	CERAMIC CHIP	0.1uF 10% 25V	IC401	A-1778-942-A	IC R5F364AEDFA (for SERVICE)	
C695	1-126-933-11	ELECT	100uF 20% 16V	IC407	6-712-027-01	IC R2A15216FP	
C696	1-126-961-11	ELECT	2.2uF 20% 50V	IC600	6-713-034-01	IC KIA7812API-U/PF	
C697	1-100-597-91	CERAMIC CHIP	0.1uF 10% 25V	IC602	6-713-032-01	IC KIA7809API-U/PF	
C698	1-100-597-91	CERAMIC CHIP	0.1uF 10% 25V	IC603	6-701-761-01	IC uPC3533AHF	
C699	1-126-157-11	ELECT	10uF 20% 16V	IC677	6-712-617-01	IC SI-8008TM-TLS	
		< CONNECTOR >		IC678	6-713-826-01	IC SI-8001FFFEK	
CN220	1-784-770-11	CONNECTOR, FFC 9P				< JACK >	
CN402	1-779-277-11	CONNECTOR, FFC (LIF (NON-ZIF)) 9P		J120	1-822-758-11	JACK, PIN 2P (PC IN)	
CN403	1-568-830-11	CONNECTOR, FFC 11P				< JACK >	
			(GTR55/GTR77)				
CN404	1-564-706-11	PIN, CONNECTOR (SMALL TYPE) 4P					
			(GTR33)				
CN405	1-784-784-11	CONNECTOR, FFC 23P		JK500	1-780-812-11	TERMINAL BOARD (SPEAKER) (SUBWOOFER)	(GTR33/GTR55)
CN410	1-784-774-11	CONNECTOR, FFC 13P		JK501	1-820-067-21	TERMINAL BOARD (SPEAKER) (SUBWOOFER)	(GTR77)
CN450	1-784-770-11	CONNECTOR, FFC 9P (E4)				< JUMPER RESISTOR >	
CN470	1-564-709-11	PIN, CONNECTOR (SMALL TYPE) 7P		JR103	1-216-864-11	SHORT CHIP	0
* CN479	1-573-094-11	SOCKET, CONNECTOR 13P		JR104	1-216-864-11	SHORT CHIP	0
* CN601	1-564-725-11	PIN, CONNECTOR (SMALL TYPE) 9P		JR401	1-216-296-11	SHORT CHIP	0
				JR402	1-216-296-11	SHORT CHIP	0
				JR403	1-216-864-11	SHORT CHIP	0
* CN690	1-564-518-11	PLUG, CONNECTOR 3P		JR404	1-216-296-11	SHORT CHIP	0
CN691	1-779-277-11	CONNECTOR, FFC (LIF (NON-ZIF)) 9P		JR405	1-216-296-11	SHORT CHIP	0
CN692	1-779-544-21	CONNECTOR, FFC (LIF (NON-ZIF)) 7P		JR406	1-216-864-11	SHORT CHIP	0
		< DIODE >		JR407	1-216-864-11	SHORT CHIP	0
D116	6-500-848-01	DIODE MC2840-T112-1		JR408	1-216-296-11	SHORT CHIP	0
D201	6-500-848-01	DIODE MC2840-T112-1		JR409	1-216-864-11	SHORT CHIP	0
D202	6-501-817-01	DIODE MA2J1110GLS0		JR410	1-216-296-11	SHORT CHIP	0
D211	6-501-722-01	DIODE MAZ8043GMLS0		JR411	1-216-296-11	SHORT CHIP	0
D212	6-501-817-01	DIODE MA2J1110GLS0		JR412	1-216-864-11	SHORT CHIP	0
D213	6-500-334-01	DIODE MC2836-T112-1		JR413	1-216-296-11	SHORT CHIP	0
D321	6-501-579-01	DIODE MC2837		JR414	1-216-296-11	SHORT CHIP	0
D468	6-501-817-01	DIODE MA2J1110GLS0		JR415	1-216-864-11	SHORT CHIP	0
D483	6-501-817-01	DIODE MA2J1110GLS0		JR416	1-216-296-11	SHORT CHIP	0
D484	6-501-817-01	DIODE MA2J1110GLS0		JR417	1-216-864-11	SHORT CHIP	0
D500	6-500-522-21	DIODE 10EDB40-TB3 (GTR55/GTR77)		JR418	1-216-296-11	SHORT CHIP	0
D501	6-501-817-01	DIODE MA2J1110GLS0		JR419	1-216-296-11	SHORT CHIP	0
D502	6-500-522-21	DIODE 10EDB40-TB3 (GTR55/GTR77)		JR420	1-216-296-11	SHORT CHIP	0
D601	6-502-994-01	DI D10XB60 F		JR421	1-216-296-11	SHORT CHIP	0
D610	6-500-522-21	DIODE 10EDB40-TB3					
D611	6-500-522-21	DIODE 10EDB40-TB3					
D612	6-500-522-21	DIODE 10EDB40-TB3					
D613	6-500-522-21	DIODE 10EDB40-TB3					
D620	6-502-272-01	DI RB055L-40TE25					

Ref. No.	Part No.	Description	Remark	Ref. No.	Part No.	Description	Remark
JR422	1-216-296-11	SHORT CHIP	0	Q620	8-729-620-07	TRANSISTOR	2SC3052EF-T1-LEF
JR423	1-216-864-11	SHORT CHIP	0	Q627	8-729-027-26	TRANSISTOR	DTA114YKA-T146
JR424	1-216-296-11	SHORT CHIP	0	Q628	6-551-276-01	TRANSISTOR	RT1N431C-TP-1
JR425	1-216-296-11	SHORT CHIP	0	Q640	8-729-024-43	TRANSISTOR	2SA1365-T112-1EF
JR426	1-216-296-11	SHORT CHIP	0	Q641	8-729-024-43	TRANSISTOR	2SA1365-T112-1EF
JR427	1-216-864-11	SHORT CHIP	0	Q643	8-729-047-62	TRANSISTOR	2SC3440-T12-1F
JR428	1-216-296-11	SHORT CHIP	0	Q644	8-729-047-62	TRANSISTOR	2SC3440-T12-1F
JR429	1-216-864-11	SHORT CHIP	0	Q645	8-729-024-43	TRANSISTOR	2SA1365-T112-1EF
JR430	1-216-296-11	SHORT CHIP	0	Q646	8-729-024-43	TRANSISTOR	2SA1365-T112-1EF
JR431	1-216-864-11	SHORT CHIP	0	Q647	8-729-047-62	TRANSISTOR	2SC3440-T12-1F
JR432	1-216-296-11	SHORT CHIP	0	Q648	8-729-047-62	TRANSISTOR	2SC3440-T12-1F
JR433	1-216-296-11	SHORT CHIP	0	Q655	8-729-040-76	TRANSISTOR	KTA1273-YAT
JR434	1-216-296-11	SHORT CHIP	0	Q656	8-729-620-07	TRANSISTOR	2SC3052EF-T1-LEF
JR435	1-216-296-11	SHORT CHIP	0	Q657	6-551-696-01	TRANSISTOR	ISA1235AC1TP-1EF
JR436	1-216-296-11	SHORT CHIP	0	Q658	6-551-696-01	TRANSISTOR	ISA1235AC1TP-1EF
JR437	1-216-864-11	SHORT CHIP	0	Q670	8-729-027-23	TRANSISTOR	DTA114EKA-T146
JR438	1-216-864-11	SHORT CHIP	0	Q681	6-551-276-01	TRANSISTOR	RT1N431C-TP-1 (E4)
JR439	1-216-296-11	SHORT CHIP	0	Q682	8-729-620-07	TRANSISTOR	2SC3052EF-T1-LEF (E4)
JR440	1-216-296-11	SHORT CHIP	0	Q683	8-729-620-07	TRANSISTOR	2SC3052EF-T1-LEF (E4)
JR447	1-216-296-11	SHORT CHIP	0	Q684	8-729-037-13	TRANSISTOR	KTA1271Y (E4)
JR449	1-216-296-11	SHORT CHIP	0	Q696	8-729-032-94	TRANSISTOR	2SD1859TV2Q
JR500	1-216-864-11	SHORT CHIP	0 (E4)	Q697	8-729-620-07	TRANSISTOR	2SC3052EF-T1-LEF
JR503	1-216-864-11	SHORT CHIP	0	Q698	8-729-032-94	TRANSISTOR	2SD1859TV2Q
JR634	1-216-296-11	SHORT CHIP	0				(GTR55/GTR77)
JR635	1-216-296-11	SHORT CHIP	0	Q699	8-729-037-13	TRANSISTOR	KTA1271Y
JR636	1-216-296-11	SHORT CHIP	0			< RESISTOR >	
JR637	1-216-864-11	SHORT CHIP	0				
JR638	1-216-296-11	SHORT CHIP	0	R110	1-216-845-11	METAL CHIP	100K 5% 1/10W
JR639	1-216-296-11	SHORT CHIP	0	R111	1-216-845-11	METAL CHIP	100K 5% 1/10W
JR640	1-216-864-11	SHORT CHIP	0	R112	1-216-817-11	METAL CHIP	470 5% 1/10W
		< COIL >		R113	1-216-824-11	METAL CHIP	1.8K 5% 1/10W
L623	1-400-424-21	INDUCTOR	47uH	R116	1-216-809-11	METAL CHIP	100 5% 1/10W
L624	1-457-822-11	INDUCTOR	47uH	R117	1-216-837-11	METAL CHIP	22K 5% 1/10W
		< TRANSISTOR >		R118	1-216-838-11	METAL CHIP	27K 5% 1/10W
Q115	8-729-620-07	TRANSISTOR	2SC3052EF-T1-LEF	R120	1-216-838-11	METAL CHIP	27K 5% 1/10W
Q128	8-729-620-07	TRANSISTOR	2SC3052EF-T1-LEF	R121	1-216-833-11	METAL CHIP	10K 5% 1/10W
Q178	8-729-620-07	TRANSISTOR	2SC3052EF-T1-LEF	R122	1-216-833-11	METAL CHIP	10K 5% 1/10W
Q210	8-729-620-07	TRANSISTOR	2SC3052EF-T1-LEF	R127	1-216-819-11	METAL CHIP	680 5% 1/10W
Q211	8-729-620-07	TRANSISTOR	2SC3052EF-T1-LEF	R127	1-220-373-11	METAL CHIP	620 5% 1/10W
Q212	8-729-037-13	TRANSISTOR	KTA1271Y	R128	1-216-834-11	METAL CHIP	12K 5% 1/10W
Q214	8-729-620-07	TRANSISTOR	2SC3052EF-T1-LEF	R128	1-216-835-11	METAL CHIP	15K 5% 1/10W
Q215	8-729-038-28	TRANSISTOR	RT1N441C-TP-1	R129	1-216-864-11	SHORT CHIP	0
Q230	8-729-620-07	TRANSISTOR	2SC3052EF-T1-LEF	R130	1-216-849-11	METAL CHIP	220K 5% 1/10W
			(GTR55/GTR77)	R131	1-216-849-11	METAL CHIP	220K 5% 1/10W
Q231	8-729-620-07	TRANSISTOR	2SC3052EF-T1-LEF	R132	1-216-829-11	METAL CHIP	4.7K 5% 1/10W
			(GTR55/GTR77)	R133	1-216-829-11	METAL CHIP	4.7K 5% 1/10W
Q300	6-551-696-01	TRANSISTOR	ISA1235AC1TP-1EF	R134	1-216-823-11	METAL CHIP	1.5K 5% 1/10W
Q301	6-551-696-01	TRANSISTOR	ISA1235AC1TP-1EF	R135	1-216-833-11	METAL CHIP	10K 5% 1/10W
Q302	8-729-620-07	TRANSISTOR	2SC3052EF-T1-LEF	R136	1-216-826-11	METAL CHIP	2.7K 5% 1/10W
Q303	8-729-620-07	TRANSISTOR	2SC3052EF-T1-LEF	R137	1-216-833-11	METAL CHIP	10K 5% 1/10W
Q402	8-729-620-07	TRANSISTOR	2SC3052EF-T1-LEF	R138	1-216-841-11	METAL CHIP	47K 5% 1/10W
Q430	8-729-620-07	TRANSISTOR	2SC3052EF-T1-LEF	R144	1-216-820-11	METAL CHIP	820 5% 1/10W
Q431	8-729-620-07	TRANSISTOR	2SC3052EF-T1-LEF	R145	1-216-823-11	METAL CHIP	1.5K 5% 1/10W
Q452	8-729-620-07	TRANSISTOR	2SC3052EF-T1-LEF	R153	1-216-833-11	METAL CHIP	10K 5% 1/10W
Q500	8-729-620-07	TRANSISTOR	2SC3052EF-T1-LEF	R177	1-216-819-11	METAL CHIP	680 5% 1/10W
Q501	8-729-620-07	TRANSISTOR	2SC3052EF-T1-LEF				(GTR55)
Q502	8-729-620-07	TRANSISTOR	2SC3052EF-T1-LEF				
Q503	8-729-620-07	TRANSISTOR	2SC3052EF-T1-LEF				

# HCD-GTR33/GTR55/GTR77

## MAIN

Ref. No.	Part No.	Description		Remark	Ref. No.	Part No.	Description		Remark
R177	1-220-373-11	METAL CHIP	620	5% 1/10W (GTR33/GTR77)	R242	1-216-830-11	METAL CHIP	5.6K	5% 1/10W (GTR55)
R178	1-216-834-11	METAL CHIP	12K	5% 1/10W (GTR33)	R242	1-218-867-11	METAL CHIP	6.8K	0.5% 1/10W (GTR77)
R178	1-216-835-11	METAL CHIP	15K	5% 1/10W (GTR55/GTR77)	R243	1-216-821-11	METAL CHIP	1K	5% 1/10W
R179	1-216-864-11	SHORT CHIP	0		R270	1-216-829-11	METAL CHIP	4.7K	5% 1/10W (GTR33)
R182	1-216-829-11	METAL CHIP	4.7K	5% 1/10W	R270	1-216-830-11	METAL CHIP	5.6K	5% 1/10W (GTR55/GTR77)
R183	1-216-829-11	METAL CHIP	4.7K	5% 1/10W	R271	1-216-817-11	METAL CHIP	470	5% 1/10W
R184	1-216-823-11	METAL CHIP	1.5K	5% 1/10W	R272	1-216-994-11	METAL CHIP	13K	5% 1/10W (GTR33)
R185	1-216-823-11	METAL CHIP	1.5K	5% 1/10W	R272	1-218-725-11	METAL CHIP	24K	0.5% 1/10W (GTR55/GTR77)
R186	1-216-826-11	METAL CHIP	2.7K	5% 1/10W	R276	1-216-841-11	METAL CHIP	47K	5% 1/10W
R187	1-216-833-11	METAL CHIP	10K	5% 1/10W	R277	1-216-841-11	METAL CHIP	47K	5% 1/10W
R188	1-216-841-11	METAL CHIP	47K	5% 1/10W	R278	1-216-821-11	METAL CHIP	1K	5% 1/10W
R190	1-216-857-11	METAL CHIP	1M	5% 1/10W	R279	1-216-821-11	METAL CHIP	1K	5% 1/10W
R192	1-216-842-11	METAL CHIP	56K	5% 1/10W	R280	1-216-838-11	METAL CHIP	27K	5% 1/10W
R194	1-216-820-11	METAL CHIP	820	5% 1/10W	R282	1-216-845-11	METAL CHIP	100K	5% 1/10W
R195	1-216-833-11	METAL CHIP	10K	5% 1/10W	R283	1-218-867-11	METAL CHIP	6.8K	0.5% 1/10W
R200	1-216-801-11	METAL CHIP	22	5% 1/10W	R284	1-216-827-11	METAL CHIP	3.3K	5% 1/10W
R201	1-216-841-11	METAL CHIP	47K	5% 1/10W	R285	1-216-841-11	METAL CHIP	47K	5% 1/10W
R202	1-216-809-11	METAL CHIP	100	5% 1/10W	R286	1-216-841-11	METAL CHIP	47K	5% 1/10W
R204	1-216-839-11	METAL CHIP	33K	5% 1/10W	R288	1-216-841-11	METAL CHIP	47K	5% 1/10W
R210	1-216-825-11	METAL CHIP	2.2K	5% 1/10W	R289	1-216-821-11	METAL CHIP	1K	5% 1/10W
R211	1-216-845-11	METAL CHIP	100K	5% 1/10W	R291	1-218-867-11	METAL CHIP	6.8K	0.5% 1/10W
R212	1-216-833-11	METAL CHIP	10K	5% 1/10W	R292	1-216-833-11	METAL CHIP	10K	5% 1/10W
R213	1-216-845-11	METAL CHIP	100K	5% 1/10W	R300	1-216-817-11	METAL CHIP	470	5% 1/10W
R214	1-216-819-11	METAL CHIP	680	5% 1/10W	R301	1-216-817-11	METAL CHIP	470	5% 1/10W
R215	1-216-833-11	METAL CHIP	10K	5% 1/10W	R302	1-216-825-11	METAL CHIP	2.2K	5% 1/10W
R216	1-216-837-11	METAL CHIP	22K	5% 1/10W	R303	1-216-819-11	METAL CHIP	680	5% 1/10W
R218	1-216-833-11	METAL CHIP	10K	5% 1/10W	R304	1-216-841-11	METAL CHIP	47K	5% 1/10W
R220	1-216-829-11	METAL CHIP	4.7K	5% 1/10W (GTR33)	R307	1-216-833-11	METAL CHIP	10K	5% 1/10W
R220	1-216-830-11	METAL CHIP	5.6K	5% 1/10W (GTR55/GTR77)	R322	1-216-837-11	METAL CHIP	22K	5% 1/10W
R221	1-216-817-11	METAL CHIP	470	5% 1/10W	R323	1-216-837-11	METAL CHIP	22K	5% 1/10W
R222	1-216-994-11	METAL CHIP	13K	5% 1/10W (GTR33)	R324	1-216-837-11	METAL CHIP	22K	5% 1/10W
R222	1-218-725-11	METAL CHIP	24K	0.5% 1/10W (GTR55/GTR77)	R325	1-216-837-11	METAL CHIP	22K	5% 1/10W
R223	1-216-825-11	METAL CHIP	2.2K	5% 1/10W	R326	1-216-837-11	METAL CHIP	22K	5% 1/10W
R224	1-216-825-11	METAL CHIP	2.2K	5% 1/10W	R327	1-216-837-11	METAL CHIP	22K	5% 1/10W
R225	1-216-828-11	METAL CHIP	3.9K	5% 1/10W (EXCEPT E4)	R328	1-216-837-11	METAL CHIP	22K	5% 1/10W
R225	1-218-867-11	METAL CHIP	6.8K	0.5% 1/10W (E4)	R329	1-216-833-11	METAL CHIP	10K	5% 1/10W
R226	1-216-828-11	METAL CHIP	3.9K	5% 1/10W (EXCEPT E4)	R330	1-216-833-11	METAL CHIP	10K	5% 1/10W
R226	1-218-867-11	METAL CHIP	6.8K	0.5% 1/10W (E4)	R361	1-216-833-11	METAL CHIP	10K	5% 1/10W
R227	1-216-841-11	METAL CHIP	47K	5% 1/10W	R364	1-216-833-11	METAL CHIP	10K	5% 1/10W
R228	1-216-821-11	METAL CHIP	1K	5% 1/10W	R365	1-216-833-11	METAL CHIP	10K	5% 1/10W
R229	1-216-821-11	METAL CHIP	1K	5% 1/10W	R380	1-216-809-11	METAL CHIP	100	5% 1/10W
R235	1-216-827-11	METAL CHIP	3.3K	5% 1/10W	R381	1-216-835-11	METAL CHIP	15K	5% 1/10W
R236	1-216-829-11	METAL CHIP	4.7K	5% 1/10W	R390	1-216-809-11	METAL CHIP	100	5% 1/10W
R237	1-216-815-11	METAL CHIP	330	5% 1/10W (GTR55/GTR77)	R391	1-216-833-11	METAL CHIP	10K	5% 1/10W
R238	1-216-821-11	METAL CHIP	1K	5% 1/10W	R392	1-216-827-11	METAL CHIP	3.3K	5% 1/10W (GTR55)
R239	1-216-845-11	METAL CHIP	100K	5% 1/10W	R392	1-218-867-11	METAL CHIP	6.8K	0.5% 1/10W (GTR77)
R240	1-216-845-11	METAL CHIP	100K	5% 1/10W	R392	1-216-864-11	SHORT CHIP	0 (GTR33)	
R241	1-216-821-11	METAL CHIP	1K	5% 1/10W	R393	1-218-867-11	METAL CHIP	6.8K	0.5% 1/10W (E4)
R242	1-216-827-11	METAL CHIP	3.3K	5% 1/10W (GTR33)	R393	1-216-841-11	METAL CHIP	47K	5% 1/10W (EXCEPT E4)
					R394	1-216-835-11	METAL CHIP	15K	5% 1/10W
					R395	1-216-835-11	METAL CHIP	15K	5% 1/10W
					R397	1-216-835-11	METAL CHIP	15K	5% 1/10W



Ref. No.	Part No.	Description	Remark	Ref. No.	Part No.	Description	Remark
R398	1-216-809-11	METAL CHIP	100 5% 1/10W	R619	1-218-839-11	METAL CHIP	470 0.5% 1/10W
R399	1-216-809-11	METAL CHIP	100 5% 1/10W	R620	1-218-869-11	METAL CHIP	8.2K 0.5% 1/10W
R404	1-216-809-11	METAL CHIP	100 5% 1/10W	R621	1-218-839-11	METAL CHIP	470 0.5% 1/10W
R409	1-216-833-11	METAL CHIP	10K 5% 1/10W	R622	1-218-835-11	METAL CHIP	330 0.5% 1/10W
R410	1-219-570-11	METAL CHIP	10M 5% 1/10W	R623	1-216-821-11	METAL CHIP	1K 5% 1/10W
R411	1-216-849-11	METAL CHIP	220K 5% 1/10W	R627	1-246-024-21	METAL CHIP	150 5% 1/2W
R422	1-216-821-11	METAL CHIP	1K 5% 1/10W	R633	1-216-837-11	METAL CHIP	22K 5% 1/10W
R423	1-216-821-11	METAL CHIP	1K 5% 1/10W	R634	1-216-837-11	METAL CHIP	22K 5% 1/10W
R424	1-216-821-11	METAL CHIP	1K 5% 1/10W	R635	1-216-827-11	METAL CHIP	3.3K 5% 1/10W
R425	1-216-821-11	METAL CHIP	1K 5% 1/10W	R635	1-216-828-11	METAL CHIP	3.9K 5% 1/10W
R426	1-216-821-11	METAL CHIP	1K 5% 1/10W				(GTR55/GTR77)
R427	1-216-821-11	METAL CHIP	1K 5% 1/10W	R636	1-216-864-11	SHORT CHIP	0
R428	1-216-821-11	METAL CHIP	1K 5% 1/10W	R637	1-215-891-11	METAL OXIDE	680 5% 2W
R431	1-216-809-11	METAL CHIP	100 5% 1/10W				(GTR55/GTR77)
R432	1-216-809-11	METAL CHIP	100 5% 1/10W	R637	1-216-455-11	METAL OXIDE	560 5% 2W
R434	1-216-809-11	METAL CHIP	100 5% 1/10W				(GTR33)
R439	1-216-809-11	METAL CHIP	100 5% 1/10W	R638	1-215-891-11	METAL OXIDE	680 5% 2W
R440	1-216-809-11	METAL CHIP	100 5% 1/10W				(GTR55/GTR77)
R441	1-216-809-11	METAL CHIP	100 5% 1/10W	R638	1-216-455-11	METAL OXIDE	560 5% 2W
R462	1-216-809-11	METAL CHIP	100 5% 1/10W				(GTR33)
R463	1-216-809-11	METAL CHIP	100 5% 1/10W	R640	1-246-024-21	METAL CHIP	150 5% 1/2W
R466	1-216-809-11	METAL CHIP	100 5% 1/10W	R641	1-216-817-11	METAL CHIP	470 5% 1/10W
R467	1-216-809-11	METAL CHIP	100 5% 1/10W	R642	1-216-841-11	METAL CHIP	47K 5% 1/10W
R468	1-216-813-11	METAL CHIP	220 5% 1/10W	R643	1-216-817-11	METAL CHIP	470 5% 1/10W
R474	1-216-809-11	METAL CHIP	100 5% 1/10W	R644	1-216-841-11	METAL CHIP	47K 5% 1/10W
R481	1-216-821-11	METAL CHIP	1K 5% 1/10W	R645	1-216-818-11	METAL CHIP	560 5% 1/10W
R483	1-216-837-11	METAL CHIP	22K 5% 1/10W	R646	1-216-818-11	METAL CHIP	560 5% 1/10W
R484	1-216-845-11	METAL CHIP	100K 5% 1/10W	R647	1-216-841-11	METAL CHIP	47K 5% 1/10W
R491	1-216-809-11	METAL CHIP	100 5% 1/10W	R648	1-216-841-11	METAL CHIP	47K 5% 1/10W
R492	1-216-841-11	METAL CHIP	47K 5% 1/10W	R649	1-216-817-11	METAL CHIP	470 5% 1/10W
R493	1-216-833-11	METAL CHIP	10K 5% 1/10W	R650	1-216-841-11	METAL CHIP	47K 5% 1/10W
			(GTR55/GTR77)	R651	1-216-817-11	METAL CHIP	470 5% 1/10W
			(EXCEPT E4)	R652	1-216-841-11	METAL CHIP	47K 5% 1/10W
R493	1-216-841-11	METAL CHIP	47K 5% 1/10W	R653	1-216-818-11	METAL CHIP	560 5% 1/10W
			(E4)	R654	1-216-818-11	METAL CHIP	560 5% 1/10W
R494	1-216-817-11	METAL CHIP	470 5% 1/10W	R655	1-216-841-11	METAL CHIP	47K 5% 1/10W
R495	1-216-817-11	METAL CHIP	470 5% 1/10W	R656	1-216-841-11	METAL CHIP	47K 5% 1/10W
R497	1-216-817-11	METAL CHIP	470 5% 1/10W	R657	1-216-790-11	METAL CHIP	2.7 5% 1/10W
R500	1-216-821-11	METAL CHIP	1K 5% 1/10W	R658	1-216-790-11	METAL CHIP	2.7 5% 1/10W
R502	1-216-821-11	METAL CHIP	1K 5% 1/10W	R659	1-216-801-11	METAL CHIP	22 5% 1/10W
R504	1-216-821-11	METAL CHIP	1K 5% 1/10W	R660	1-216-790-11	METAL CHIP	2.7 5% 1/10W
R513	1-216-821-11	METAL CHIP	1K 5% 1/10W	R662	1-216-839-11	METAL CHIP	33K 5% 1/10W
R520	1-216-833-11	METAL CHIP	10K 5% 1/10W	R663	1-216-837-11	METAL CHIP	22K 5% 1/10W
			(E4)	R664	1-216-825-11	METAL CHIP	2.2K 5% 1/10W
R525	1-216-825-11	METAL CHIP	2.2K 5% 1/10W	R666	1-216-815-11	METAL CHIP	330 5% 1/10W
			(E4)	R668	1-216-825-11	METAL CHIP	2.2K 5% 1/10W
R526	1-216-825-11	METAL CHIP	2.2K 5% 1/10W	R669	1-216-853-11	METAL CHIP	470K 5% 1/10W
			(E4)	R674	1-216-833-11	METAL CHIP	10K 5% 1/10W
R530	1-216-821-11	METAL CHIP	1K 5% 1/10W	R683	1-216-821-11	METAL CHIP	1K 5% 1/10W
			(GTR55/GTR77)				(E4)
R531	1-216-821-11	METAL CHIP	1K 5% 1/10W	R690	1-216-826-11	METAL CHIP	2.7K 5% 1/10W
			(GTR55/GTR77)	R694	1-216-826-11	METAL CHIP	2.7K 5% 1/10W
R543	1-216-833-11	METAL CHIP	10K 5% 1/10W	R695	1-216-837-11	METAL CHIP	22K 5% 1/10W
R601	1-218-855-11	METAL CHIP	2.2K 0.5% 1/10W	R697	1-216-821-11	METAL CHIP	1K 5% 1/10W
R602	1-218-855-11	METAL CHIP	2.2K 0.5% 1/10W	R698	1-216-829-11	METAL CHIP	4.7K 5% 1/10W
R603	1-218-835-11	METAL CHIP	330 0.5% 1/10W	R699	1-216-829-11	METAL CHIP	4.7K 5% 1/10W
R613	1-216-825-11	METAL CHIP	2.2K 5% 1/10W				< RELAY >
R614	1-216-817-11	METAL CHIP	470 5% 1/10W	RY500	1-755-653-11	RELAY	
R615	1-216-833-11	METAL CHIP	10K 5% 1/10W				
R616	1-216-818-11	METAL CHIP	560 5% 1/10W				
R617	1-216-825-11	METAL CHIP	2.2K 5% 1/10W				

# HCD-GTR33/GTR55/GTR77

**MAIN**   **MIC**   **POWER**

Ref. No.	Part No.	Description	Remark
		< VIBRATOR >	
X401	1-760-252-12	RELAY (32.768kHz)	
X402	1-781-472-21	VIBRATOR, CERAMIC (8MHz)	
*****			
		MIC BOARD *****	
		< CAPACITOR >	
C700	1-164-156-11	CERAMIC CHIP 0.1uF	25V
C701	1-164-156-11	CERAMIC CHIP 0.1uF	25V
C702	1-162-964-11	CERAMIC CHIP 0.001uF	10% 50V
C707	1-124-257-00	ELECT 2.2uF	20% 50V
C708	1-162-964-11	CERAMIC CHIP 0.001uF	10% 50V
C709	1-162-960-11	CERAMIC CHIP 220PF	10% 50V
C710	1-126-157-11	ELECT 10uF	20% 16V
C711	1-124-584-00	ELECT 100uF	20% 6.3V
C712	1-162-923-11	CERAMIC CHIP 47PF	5% 50V
C713	1-124-257-00	ELECT 2.2uF	20% 50V
C716	1-124-257-00	ELECT 2.2uF	20% 50V
C719	1-162-961-11	CERAMIC CHIP 330PF	10% 50V
C720	1-124-257-00	ELECT 2.2uF	20% 50V
C721	1-164-156-11	CERAMIC CHIP 0.1uF	25V
C722	1-164-218-11	CERAMIC CHIP 180PF	5% 50V
C724	1-124-463-00	ELECT 0.1uF	20% 50V
C777	1-162-964-11	CERAMIC CHIP 0.001uF	10% 50V
C779	1-164-156-11	CERAMIC CHIP 0.1uF	25V
C780	1-162-964-11	CERAMIC CHIP 0.001uF	10% 50V
C781	1-162-960-11	CERAMIC CHIP 220PF	10% 50V
C782	1-162-964-11	CERAMIC CHIP 0.001uF	10% 50V
		< DIODE >	
D700	6-501-579-01	DIODE MC2837	
D701	6-501-579-01	DIODE MC2837	
		< IC >	
IC700	8-759-278-58	IC NJM4558V-TE2	
		< JACK >	
J700	1-822-757-11	JACK (LARGE TYPE) (MIC)	
J702	1-794-702-11	JACK, HEADPHONE (PHONES)	
		< JUMPER RESISTOR >	
JR701	1-216-864-11	SHORT CHIP 0	
JR702	1-216-864-11	SHORT CHIP 0	
JR703	1-216-296-11	SHORT CHIP 0	
JR704	1-216-296-11	SHORT CHIP 0	
JR705	1-216-296-11	SHORT CHIP 0	
JR706	1-216-296-11	SHORT CHIP 0	
JR707	1-216-295-91	SHORT CHIP 0	
JR708	1-216-864-11	SHORT CHIP 0	
JR709	1-216-864-11	SHORT CHIP 0	
		< RESISTOR >	
R700	1-216-821-11	METAL CHIP 1K	5% 1/10W
R701	1-216-845-11	METAL CHIP 100K	5% 1/10W
R702	1-216-833-11	METAL CHIP 10K	5% 1/10W
R704	1-216-829-11	METAL CHIP 4.7K	5% 1/10W
R705	1-216-829-11	METAL CHIP 4.7K	5% 1/10W

Ref. No.	Part No.	Description	Remark
R706	1-216-823-11	METAL CHIP 1.5K	5% 1/10W
R711	1-216-833-11	METAL CHIP 10K	5% 1/10W
R712	1-216-836-11	METAL CHIP 18K	5% 1/10W
R714	1-216-849-11	METAL CHIP 220K	5% 1/10W
R715	1-216-809-11	METAL CHIP 100	5% 1/10W
R716	1-216-845-11	METAL CHIP 100K	5% 1/10W
R720	1-216-845-11	METAL CHIP 100K	5% 1/10W
R721	1-216-836-11	METAL CHIP 18K	5% 1/10W
R722	1-216-833-11	METAL CHIP 10K	5% 1/10W
R723	1-216-836-11	METAL CHIP 18K	5% 1/10W
R724	1-216-841-11	METAL CHIP 47K	5% 1/10W
R725	1-216-833-11	METAL CHIP 10K	5% 1/10W
		< VARIABLE RESISTOR >	
RV700	1-227-452-11	RES, VAR, CARBON 50K (MIC LEVEL)	
*****			
		POWER BOARD *****	
	7-685-647-79	SCREW +BVTP 3X10 TYPE2 IT-3 (GTR55/GTR77)	
		< CAPACITOR >	
C801	1-130-777-00	MYLAR 0.1uF	5% 100V
C802	1-130-777-00	MYLAR 0.1uF	5% 100V
C803	1-137-840-11	ELECT (BLOCK) 2200uF	20% 63V (GTR33)
C803	1-137-842-11	ELECT (BLOCK) 2200uF	20% 80V (GTR55/GTR77)
C804	1-137-840-11	ELECT (BLOCK) 2200uF	20% 63V (GTR33)
C804	1-137-842-11	ELECT (BLOCK) 2200uF	20% 80V (GTR55/GTR77)
C805	1-127-811-11	ELECT (BLOCK) 3300uF	20% 50V (GTR77)
C805	1-137-839-11	ELECT (BLOCK) 2200uF	20% 50V (GTR55)
C806	1-127-811-11	ELECT (BLOCK) 3300uF	20% 50V (GTR77)
C806	1-137-839-11	ELECT (BLOCK) 2200uF	20% 50V (GTR55)
C807	1-130-777-00	MYLAR 0.1uF	5% 100V (GTR55/GTR77)
C808	1-130-777-00	MYLAR 0.1uF	5% 100V (GTR55/GTR77)
C809	1-126-964-11	ELECT 10uF	20% 50V
C810	1-126-964-11	ELECT 10uF	20% 50V
C811	1-126-964-11	ELECT 10uF	20% 50V
C812	1-162-964-11	CERAMIC CHIP 0.001uF	10% 50V
C813	1-162-964-11	CERAMIC CHIP 0.001uF	10% 50V
C814	1-162-964-11	CERAMIC CHIP 0.001uF	10% 50V
C815	1-162-927-11	CERAMIC CHIP 100PF	5% 50V
C816	1-162-927-11	CERAMIC CHIP 100PF	5% 50V
C817	1-162-927-11	CERAMIC CHIP 100PF	5% 50V
C818	1-126-967-11	ELECT 47uF	20% 50V
C819	1-126-967-11	ELECT 47uF	20% 50V
C820	1-126-967-11	ELECT 47uF	20% 50V
C826	1-128-552-51	ELECT 47uF	20% 63V (GTR33)
C826	1-128-562-11	ELECT 47uF	20% 100V (GTR55/GTR77)



Ref. No.	Part No.	Description	Remark	Ref. No.	Part No.	Description	Remark
C827	1-128-552-51	ELECT	47uF 20% 63V (GTR33)	R821	1-216-823-11	METAL CHIP	1.5K 5% 1/10W
C827	1-128-562-11	ELECT	47uF 20% 100V (GTR55/GTR77)	R822	1-216-821-11	METAL CHIP	1K 5% 1/10W
C829	1-104-658-91	ELECT	100uF 20% 10V	R823	1-216-823-11	METAL CHIP	1.5K 5% 1/10W
C830	1-126-961-11	ELECT	2.2uF 20% 50V	R824	1-216-841-11	METAL CHIP	47K 5% 1/10W
C837	1-115-339-11	CERAMIC CHIP	0.1uF 10% 50V	R825	1-216-841-11	METAL CHIP	47K 5% 1/10W
C838	1-115-339-11	CERAMIC CHIP	0.1uF 10% 50V	R826	1-216-841-11	METAL CHIP	47K 5% 1/10W
C839	1-115-339-11	CERAMIC CHIP	0.1uF 10% 50V	R827	1-216-822-11	METAL CHIP	1.2K 5% 1/10W (GTR33/GTR55)
C840	1-115-339-11	CERAMIC CHIP	0.1uF 10% 50V	R827	1-216-824-11	METAL CHIP	1.8K 5% 1/10W (GTR77)
C851	1-115-339-11	CERAMIC CHIP	0.1uF 10% 50V	R828	1-216-822-11	METAL CHIP	1.2K 5% 1/10W (GTR33/GTR55)
C852	1-115-339-11	CERAMIC CHIP	0.1uF 10% 50V	R828	1-216-824-11	METAL CHIP	1.8K 5% 1/10W (GTR77)
		< CONNECTOR >		R829	1-216-817-11	METAL CHIP	470 5% 1/10W (GTR55/GTR77)
* CN801	1-573-087-11	PIN, CONNECTOR 13P		R829	1-216-818-11	METAL CHIP	560 5% 1/10W (GTR33)
		< DIODE >		R830	1-216-841-11	METAL CHIP	47K 5% 1/10W
D800	6-502-994-01	DI D10XB60 F		R831	1-220-893-11	METAL	0.22 10% 5W
D801	6-502-994-01	DI D10XB60 F (GTR55/GTR77)		R832	1-220-893-11	METAL	0.22 10% 5W
D802	6-500-334-01	DIODE MC2836-T112-1		R833	1-220-893-11	METAL	0.22 10% 5W
D803	6-501-817-01	DIODE MA2J1110GLS0		R834	1-216-821-11	METAL CHIP	1K 5% 1/10W
D804	6-501-778-01	DIODE MAZ8160GMLS0	(GTR55/GTR77)	R835	1-216-821-11	METAL CHIP	1K 5% 1/10W (GTR33)
D805	6-501-778-01	DIODE MAZ8160GMLS0	(GTR55/GTR77)	R835	1-216-822-11	METAL CHIP	1.2K 5% 1/10W (GTR55/GTR77)
D806	6-501-412-01	DIODE SF5S6 (GTR55/GTR77)		R836	1-216-835-11	METAL CHIP	15K 5% 1/10W (GTR55/GTR77)
D807	6-501-817-01	DIODE MA2J1110GLS0		R836	1-216-836-11	METAL CHIP	18K 5% 1/10W (GTR33)
D810	6-501-412-01	DIODE SF5S6 (GTR55/GTR77)		R838	1-216-843-11	METAL CHIP	68K 5% 1/10W (GTR33)
D811	6-501-817-01	DIODE MA2J1110GLS0		R838	1-216-844-11	METAL CHIP	82K 5% 1/10W (GTR55/GTR77)
		< IC >		R839	1-216-843-11	METAL CHIP	68K 5% 1/10W (GTR33)
△ IC800	6-600-674-01	IC STK416-130-E (GTR77)		R839	1-216-844-11	METAL CHIP	82K 5% 1/10W (GTR55/GTR77)
△ IC800	6-600-675-01	IC STK416-120-E (GTR55)		R842	1-215-871-11	METAL OXIDE	2.2K 5% 1W (GTR55/GTR77)
△ IC800	6-712-281-01	IC STK433-320-E (GTR33)		R843	1-215-871-11	METAL OXIDE	2.2K 5% 1W (GTR55/GTR77)
		< JACK >		R848	1-216-827-11	METAL CHIP	3.3K 5% 1/10W
JK800	1-820-067-21	TERMINAL BOARD (SPEAKER) (FRONT SPEAKER)		R849	1-216-838-11	METAL CHIP	27K 5% 1/10W
JK801	1-820-067-21	TERMINAL BOARD (SPEAKER) (SATELLITE SPEAKER) (GTR77)		R850	1-216-829-11	METAL CHIP	4.7K 5% 1/10W
		< JUMPER RESISTOR >		R851	1-216-833-11	METAL CHIP	10K 5% 1/10W
JR810	1-216-296-11	SHORT CHIP	0	R852	1-216-817-11	METAL CHIP	470 5% 1/10W (GTR33)
JR811	1-216-296-11	SHORT CHIP	0	R852	1-216-864-11	SHORT CHIP	0 (GTR55/GTR77)
		< TRANSISTOR >		R853	1-216-833-11	METAL CHIP	10K 5% 1/10W (GTR33)
Q800	6-551-268-01	TRANSISTOR	2SC5625	R854	1-216-841-11	METAL CHIP	47K 5% 1/10W
Q801	6-551-268-01	TRANSISTOR	2SC5625	R855	1-216-845-11	METAL CHIP	100K 5% 1/10W
Q802	6-551-268-01	TRANSISTOR	2SC5625	R856	1-216-841-11	METAL CHIP	47K 5% 1/10W
Q803	8-729-620-07	TRANSISTOR	2SC3052EF-T1-LEF	R857	1-216-837-11	METAL CHIP	22K 5% 1/10W
Q806	8-729-620-07	TRANSISTOR	2SC3052EF-T1-LEF	R860	1-216-835-11	METAL CHIP	15K 5% 1/10W (GTR55/GTR77)
Q807	8-729-620-07	TRANSISTOR	2SC3052EF-T1-LEF	R860	1-216-836-11	METAL CHIP	18K 5% 1/10W (GTR33)
Q808	8-729-620-07	TRANSISTOR	2SC3052EF-T1-LEF	△ R861	1-217-637-55	FUSIBLE	1 5% 1/4W
Q809	6-551-696-01	TRANSISTOR	ISA1235AC1TP-1EF	△ R862	1-250-336-11	FUSIBLE	100 5% 1/2W
Q811	8-729-620-07	TRANSISTOR	2SC3052EF-T1-LEF	R863	1-216-821-11	METAL CHIP	1K 5% 1/10W
		< RESISTOR >					
R806	1-216-845-11	METAL CHIP	100K 5% 1/10W (GTR55/GTR77)				
R807	1-216-845-11	METAL CHIP	100K 5% 1/10W (GTR55/GTR77)				

# HCD-GTR33/GTR55/GTR77

POWER TC

Ref. No.	Part No.	Description	Remark
△ R865	1-250-336-11	FUSIBLE	100 5% 1/2W
R866	1-202-926-11	METAL CHIP	36K 5% 1/10W (GTR55/GTR77)
R866	1-216-840-11	METAL CHIP	39K 5% 1/10W (GTR33)
R868	1-216-839-11	METAL CHIP	33K 5% 1/10W
R881	1-216-841-11	METAL CHIP	47K 5% 1/10W
R882	1-216-843-11	METAL CHIP	68K 5% 1/10W (GTR33)
R882	1-216-844-11	METAL CHIP	82K 5% 1/10W (GTR55/GTR77)
R883	1-216-821-11	METAL CHIP	1K 5% 1/10W
R884	1-216-841-11	METAL CHIP	47K 5% 1/10W
R885	1-216-842-11	METAL CHIP	56K 5% 1/10W
R887	1-216-864-11	SHORT CHIP	0
R889	1-216-834-11	METAL CHIP	12K 5% 1/10W (GTR55/GTR77)
R889	1-216-839-11	METAL CHIP	33K 5% 1/10W (GTR33)
R891	1-216-845-11	METAL CHIP	100K 5% 1/10W
R892	1-216-845-11	METAL CHIP	100K 5% 1/10W
R905	1-250-312-21	METAL CHIP	10 5% 1/2W
R906	1-250-312-21	METAL CHIP	10 5% 1/2W
R910	1-250-312-21	METAL CHIP	10 5% 1/2W
		< RELAY >	
RY800	1-755-653-11	RELAY	
		< THERMISTOR >	
TH802	1-804-045-11	THERMISTOR	
*****			
		TC BOARD (E4)	*****
		< CAPACITOR >	
C501	1-104-658-91	ELECT	100uF 20% 10V
C502	1-104-658-91	ELECT	100uF 20% 10V
C503	1-162-966-11	CERAMIC CHIP	0.0022uF 10% 50V
C504	1-162-966-11	CERAMIC CHIP	0.0022uF 10% 50V
C505	1-162-970-11	CERAMIC CHIP	0.01uF 10% 25V
C506	1-162-970-11	CERAMIC CHIP	0.01uF 10% 25V
C509	1-127-804-91	CERAMIC CHIP	100PF 1% 50V
C510	1-127-804-91	CERAMIC CHIP	100PF 1% 50V
C511	1-162-960-11	CERAMIC CHIP	220PF 10% 50V
C512	1-162-960-11	CERAMIC CHIP	220PF 10% 50V
C513	1-126-160-11	ELECT	1uF 20% 50V
C514	1-126-160-11	ELECT	1uF 20% 50V
C515	1-126-786-11	ELECT	47uF 20% 16V
C516	1-126-947-11	ELECT	47uF 20% 35V
C517	1-162-964-11	CERAMIC CHIP	0.001uF 10% 50V
C519	1-162-962-11	CERAMIC CHIP	470PF 10% 50V
C520	1-162-962-11	CERAMIC CHIP	470PF 10% 50V
C521	1-125-837-91	CERAMIC CHIP	1uF 10% 6.3V
C522	1-125-837-91	CERAMIC CHIP	1uF 10% 6.3V
C523	1-125-837-91	CERAMIC CHIP	1uF 10% 6.3V
C524	1-125-837-91	CERAMIC CHIP	1uF 10% 6.3V
C525	1-162-923-11	CERAMIC CHIP	47PF 5% 50V
C526	1-162-923-11	CERAMIC CHIP	47PF 5% 50V
C527	1-162-962-11	CERAMIC CHIP	470PF 10% 50V
C528	1-162-962-11	CERAMIC CHIP	470PF 10% 50V

Ref. No.	Part No.	Description	Remark
C529	1-162-961-11	CERAMIC CHIP	330PF 10% 50V
C530	1-162-961-11	CERAMIC CHIP	330PF 10% 50V
C531	1-162-970-11	CERAMIC CHIP	0.01uF 10% 25V
C532	1-162-970-11	CERAMIC CHIP	0.01uF 10% 25V
C533	1-162-966-11	CERAMIC CHIP	0.0022uF 10% 50V
C534	1-162-966-11	CERAMIC CHIP	0.0022uF 10% 50V
C535	1-162-966-11	CERAMIC CHIP	0.0022uF 10% 50V
C536	1-162-966-11	CERAMIC CHIP	0.0022uF 10% 50V
C537	1-162-966-11	CERAMIC CHIP	0.0022uF 10% 50V
C538	1-162-970-11	CERAMIC CHIP	0.01uF 10% 25V
C539	1-115-156-11	CERAMIC CHIP	1uF 10V
C540	1-130-479-91	MYLAR	0.0047uF 5% 50V
C542	1-126-796-11	ELECT	22uF 20% 50V
C543	1-162-964-11	CERAMIC CHIP	0.001uF 10% 50V
C545	1-100-597-91	CERAMIC CHIP	0.1uF 10% 25V
C546	1-100-597-91	CERAMIC CHIP	0.1uF 10% 25V
C548	1-162-964-11	CERAMIC CHIP	0.001uF 10% 50V
C549	1-164-156-11	CERAMIC CHIP	0.1uF 25V
		< CONNECTOR >	
* CN501	1-564-710-11	PIN, CONNECTOR (SMALL TYPE) 8P	
CN502	1-784-731-11	CONNECTOR, FFC 9P	
		< IC >	
IC501	8-759-100-96	IC uPC4558G2	
IC502	8-759-100-96	IC uPC4558G2	
		< JUMPER RESISTOR >	
JR501	1-216-864-11	SHORT CHIP	0
JR502	1-216-864-11	SHORT CHIP	0
JR503	1-216-864-11	SHORT CHIP	0
JR504	1-216-295-91	SHORT CHIP	0
JR505	1-216-295-91	SHORT CHIP	0
JR506	1-216-296-11	SHORT CHIP	0
JR507	1-216-296-11	SHORT CHIP	0
JR508	1-216-296-11	SHORT CHIP	0
JR509	1-216-296-11	SHORT CHIP	0
JR510	1-216-295-91	SHORT CHIP	0
JR511	1-216-296-11	SHORT CHIP	0
JR512	1-216-296-11	SHORT CHIP	0
JR513	1-216-296-11	SHORT CHIP	0
JR514	1-216-296-11	SHORT CHIP	0
JR515	1-216-296-11	SHORT CHIP	0
JR516	1-216-296-11	SHORT CHIP	0
JR517	1-216-296-11	SHORT CHIP	0
JR518	1-216-296-11	SHORT CHIP	0
		< COIL >	
L501	1-456-094-11	TRANSFORMER, BIAS OSCILLATION	
		< TRANSISTOR >	
Q501	8-729-119-78	TRANSISTOR	2SC2785-HFE
Q502	8-729-119-78	TRANSISTOR	2SC2785-HFE
		< RESISTOR >	
R501	1-216-825-11	METAL CHIP	2.2K 5% 1/10W
R502	1-216-825-11	METAL CHIP	2.2K 5% 1/10W
R503	1-216-825-11	METAL CHIP	2.2K 5% 1/10W
R504	1-216-825-11	METAL CHIP	2.2K 5% 1/10W
R505	1-216-834-11	METAL CHIP	12K 5% 1/10W

Ref. No.	Part No.	Description	Remark	Ref. No.	Part No.	Description	Remark
R506	1-216-834-11	METAL CHIP	12K 5%	1/10W	* CN908	1-564-509-11	PLUG, CONNECTOR 6P (GTR55/GTR77)
R507	1-216-850-11	METAL CHIP	270K 5%	1/10W	* CN909	1-564-507-11	PLUG, CONNECTOR 4P (GTR33)
R508	1-216-850-11	METAL CHIP	270K 5%	1/10W		< DIODE >	
R509	1-216-814-11	METAL CHIP	270 5%	1/10W	D901	8-719-991-33	DIODE 1SS133T-77
R510	1-216-814-11	METAL CHIP	270 5%	1/10W	D902	8-719-991-33	DIODE 1SS133T-77
R511	1-216-845-11	METAL CHIP	100K 5%	1/10W	D903	8-719-991-33	DIODE 1SS133T-77
R512	1-216-845-11	METAL CHIP	100K 5%	1/10W	D904	8-719-991-33	DIODE 1SS133T-77
R513	1-216-845-11	METAL CHIP	100K 5%	1/10W	D905	8-719-991-33	DIODE 1SS133T-77
R514	1-216-845-11	METAL CHIP	100K 5%	1/10W	D906	8-719-991-33	DIODE 1SS133T-77
R515	1-216-864-11	SHORT CHIP	0		D907	8-719-991-33	DIODE 1SS133T-77
R516	1-216-864-11	SHORT CHIP	0		D908	6-500-522-21	DIODE 10EDB40-TB3
R517	1-216-821-11	METAL CHIP	1K 5%	1/10W	D909	8-719-983-92	DIODE MTZJ-T-72-36B
R518	1-216-821-11	METAL CHIP	1K 5%	1/10W		< FUSE >	
R519	1-216-841-11	METAL CHIP	47K 5%	1/10W	△ F951	1-523-080-11	FUSE 6.3A 250V
R520	1-216-841-11	METAL CHIP	47K 5%	1/10W	△ F952	1-523-080-11	FUSE 6.3A 250V (GTR55/GTR77)
R521	1-216-841-11	METAL CHIP	47K 5%	1/10W	△ F953	1-523-080-11	FUSE 6.3A 250V (GTR55/GTR77)
R522	1-216-841-11	METAL CHIP	47K 5%	1/10W	△ F954	1-523-080-11	FUSE 6.3A 250V
R523	1-216-827-11	METAL CHIP	3.3K 5%	1/10W	△ F955	1-523-082-11	FUSE 1A 250V (GTR77: MX)
R524	1-216-827-11	METAL CHIP	3.3K 5%	1/10W	△ F956	1-523-086-11	FUSE 3.15A 250V
R525	1-216-851-11	METAL CHIP	330K 5%	1/10W		< TRANSFORMER >	
R526	1-216-851-11	METAL CHIP	330K 5%	1/10W	△ PT902	1-443-927-21	TRANSFORMER, POWER (SUB) (MX)
R527	1-216-851-11	METAL CHIP	330K 5%	1/10W	△ PT902	1-445-875-11	POWER TRANSFORMER (SUB) (EXCEPT MX)
R528	1-216-851-11	METAL CHIP	330K 5%	1/10W		< TRANSISTOR >	
R529	1-216-825-11	METAL CHIP	2.2K 5%	1/10W	Q902	8-729-048-66	TRANSISTOR 2SB1238-PQR-TV2
R530	1-216-825-11	METAL CHIP	2.2K 5%	1/10W	Q903	8-729-119-78	TRANSISTOR 2SC2785-HFE
R531	1-216-832-11	METAL CHIP	8.2K 5%	1/10W		< RESISTOR >	
R532	1-216-832-11	METAL CHIP	8.2K 5%	1/10W	R904	1-247-831-91	CARBON 1K 5% 1/4W
R533	1-216-837-11	METAL CHIP	22K 5%	1/10W	R915	1-247-847-91	CARBON 4.7K 5% 1/4W
R534	1-216-835-11	METAL CHIP	15K 5%	1/10W	R952	1-249-429-11	CARBON 10K 5% 1/4W
R535	1-216-829-11	METAL CHIP	4.7K 5%	1/10W	△ R955	1-217-637-55	FUSIBLE 1 5% 1/4W (EXCEPT GTR77: MX)
R536	1-216-829-11	METAL CHIP	4.7K 5%	1/10W	R957	1-249-424-11	CARBON 3.9K 5% 1/4W
R537	1-216-833-11	METAL CHIP	10K 5%	1/10W		< RELAY >	
R538	1-216-833-11	METAL CHIP	10K 5%	1/10W	△ RY901	1-755-334-11	RELAY, AC POWER
R539	1-216-793-11	METAL CHIP	4.7 5%	1/10W		< SWITCH >	
R540	1-216-805-11	METAL CHIP	47 5%	1/10W	△ S901	1-786-055-31	SELECTOR, VOLTAGE (E2, E51, E4)
R541	1-216-805-11	METAL CHIP	47 5%	1/10W		*****	
R543	1-216-813-11	METAL CHIP	220 5%	1/10W		USB BOARD	
R544	1-216-813-11	METAL CHIP	220 5%	1/10W		*****	
R545	1-216-817-11	METAL CHIP	470 5%	1/10W		< CAPACITOR >	
R546	1-216-817-11	METAL CHIP	470 5%	1/10W	C1002	1-165-989-11	CERAMIC CHIP 10uF 10% 6.3V
		< SWITCH >			C1003	1-126-176-11	ELECT 220uF 20% 10V
S501	1-762-369-11	SWITCH, SLIDE (REC/PB)			C1004	1-164-156-11	CERAMIC CHIP 0.1uF 25V
*****					C1005	1-165-989-11	CERAMIC CHIP 10uF 10% 6.3V
		TRANS BOARD			C1006	1-126-176-11	ELECT 220uF 20% 10V
		*****			C1007	1-164-156-11	CERAMIC CHIP 0.1uF 25V
		< CAPACITOR >			C1008	1-164-156-11	CERAMIC CHIP 0.1uF 25V
C903	1-136-153-00	FILM	0.01uF 5%	50V	C1009	1-164-156-11	CERAMIC CHIP 0.1uF 25V
C904	1-136-153-00	FILM	0.01uF 5%	50V	C1010	1-162-964-11	CERAMIC CHIP 0.001uF 10% 50V
C908	1-128-576-11	ELECT	100uF 20%	63V	C1011	1-162-964-11	CERAMIC CHIP 0.001uF 10% 50V
C909	1-126-964-11	ELECT	10uF 20%	50V			
C910	1-126-968-11	ELECT	100uF 20%	50V			
C911	1-126-767-11	ELECT	1000uF 20%	16V			
C927	1-126-962-11	ELECT	3.3uF 20%	50V			
		< CONNECTOR >					
CN901	1-691-961-11	PIN, CONNECTOR (PC BOARD) 3P					
* CN907	1-764-334-11	PLUG, CONNECTOR 11P 11P					

# HCD-GTR33/GTR55/GTR77

**USB** **VOL**

Ref. No.	Part No.	Description	Remark		
C1012	1-162-910-11	CERAMIC CHIP 5PF	0.25PF	50V	
C1013	1-162-910-11	CERAMIC CHIP 5PF	0.25PF	50V	
< CONNECTOR >					
CN1000	1-819-866-11	CONNECTOR, USB (A) (REC/PLAY B)			
CN1001	1-819-866-11	CONNECTOR, USB (A) (PLAY A)			
< DIODE >					
D1000	6-502-795-01	DI 1L0351B12COMXT02			
D1002	6-503-224-01	DI 1L0351V22F0MIT01			
D1003	6-502-795-01	DI 1L0351B12COMXT02			
D1004	6-501-579-01	DIODE MC2837			
D1005	6-501-579-01	DIODE MC2837			
D1006	6-501-579-01	DIODE MC2837			
D1007	6-501-579-01	DIODE MC2837			
D1008	6-501-579-01	DIODE MC2837			
D1009	6-501-579-01	DIODE MC2837			
D1011	6-501-743-01	DIODE MAZ8068GMLS0			
D1013	6-501-743-01	DIODE MAZ8068GMLS0			
D1015	6-501-743-01	DIODE MAZ8068GMLS0			
D1017	6-501-743-01	DIODE MAZ8068GMLS0			
D1018	6-501-743-01	DIODE MAZ8068GMLS0			
D1019	6-501-743-01	DIODE MAZ8068GMLS0			
< JUMPER RESISTOR >					
JR102	1-216-296-11	SHORT CHIP 0			
JR103	1-216-296-11	SHORT CHIP 0			
< RESISTOR >					
R1001	1-216-817-11	METAL CHIP 470	5%	1/10W	
R1002	1-216-817-11	METAL CHIP 470	5%	1/10W	
R1004	1-216-823-11	METAL CHIP 1.5K	5%	1/10W	
R1005	1-216-823-11	METAL CHIP 1.5K	5%	1/10W	
R1008	1-216-817-11	METAL CHIP 470	5%	1/10W	
R1009	1-216-817-11	METAL CHIP 470	5%	1/10W	
*****					
VOL BOARD					
*****					
< CAPACITOR >					
C1301	1-162-964-11	CERAMIC CHIP 0.001uF	10%	50V	
< RESISTOR >					
R1302	1-216-833-11	METAL CHIP 10K	5%	1/10W	
R1303	1-216-835-11	METAL CHIP 15K	5%	1/10W	
R1304	1-216-837-11	METAL CHIP 22K	5%	1/10W	
< SWITCH >					
S1301	1-487-171-11	ROTARY ENCODER (MASTER VOLUME)			
S1302	1-786-289-31	SWITCH, DETECTION (DETECTION SWITCH)			
*****					

Ref. No.	Part No.	Description	Remark
MISCELLANEOUS			
*****			
59	1-797-575-11	DECK, MECHANICAL (E4)	
103	1-828-311-51	WIRE (FLAT TYPE) (9 CORE)	
104	1-836-973-11	WIRE (FLAT TYPE) (7 CORE)	
105	1-828-975-11	WIRE (FLAT TYPE) (13 CORE)	
155	1-838-059-11	FLEXIBLE FLAT CABLE (23 CORE)	
156	1-828-964-11	WIRE (FLAT TYPE) (11 CORE) (GTR55/GTR77)	
251	1-828-952-11	WIRE (FLAT TYPE) (9 CORE)	
252	1-457-369-12	CORE, FERRITE	
255	1-693-778-31	TUNER (FM/AM)	
△ 257	1-777-071-83	CORD, POWER (E2, E51, E4)	
△ 257	1-837-312-11	CORD, POWER-SUPPLY (AR)	
△ 257	1-837-344-11	CORD, POWER-SUPPLY (MX)	
△ 258	1-569-008-21	ADAPTOR, CONVERSION (E2, E51, E4)	
401	1-840-387-31	MECHANICAL, CD	
△ 405	8-820-322-04	DEVICE, OPTICAL KHM-313CAB/C2NP (Including sled motor, spindle motor)	
407	1-828-773-51	WIRE (FLAT TYPE) (24 CORE)	
M101	1-787-344-21	FAN, DC	
△ PT901	1-445-827-11	POWER TRANSFORMER (MAIN) (GTR33: MX)	
△ PT901	1-445-828-11	POWER TRANSFORMER (MAIN) (GTR33: E4)	
△ PT901	1-445-829-11	POWER TRANSFORMER (MAIN) (GTR33: E2, E51, AR)	
△ PT901	1-445-830-11	POWER TRANSFORMER (MAIN) (GTR77: MX)	
△ PT901	1-445-831-11	POWER TRANSFORMER (MAIN) (GTR77: E4)	
△ PT901	1-445-832-11	POWER TRANSFORMER (MAIN) (GTR77: E2, E51, AR)	
△ PT901	1-445-834-11	POWER TRANSFORMER (MAIN) (GTR55: MX)	
△ PT901	1-445-835-11	POWER TRANSFORMER (MAIN) (GTR55: E2, E51, AR)	
△ PT901	1-445-836-11	POWER TRANSFORMER (MAIN) (GTR55: E4)	
*****			

