

# Service Service Service

Aulika



# Service Manual

Revision 00 July 2012

Contents	Page	Contents	Page
1. Introduction		4.8. Water level detection (water tank)	6
1.1. Required documentation	1	4.9. Descaling request	6
1.2. Necessary tools and equipment	1	4.10. Water softener	7
1.3. Materials	1		
1.4. Safety cautions	1	<b>5. Fault finding</b>	
1.5. Aulika range	2	5.1. Test mode	1
1.6. Machine external hardware	3	5.2. Diagnostic mode	6
1.7. Machine internal hardware	4	5.3. Error messages	
		<b>6. Standard checks</b>	
2. Technical data		6.1. Repairs schedule	1
2.1. Technical data	1	6.2. Service schedule	1
2.2. Machine behaviour and parameters	2	6.3. Final check	2
3. User guide			
3.1. Machine warnings	1	<b>7. Disassembly</b>	
3.2. Operator guide	2	7.1. Aesthetics	1
3.3. Operation, cleaning and maintenance	7	7.2. Coffee grinder	1
		7.3. Burrs	2
4. Operating logic		7.4. Coffee grinder motor	3
4.1. Hydraulic Circuit	1	7.5. Coil, microswitch and doser door	3
4.2. Emulsifier valve assembly	2	7.6. Doser hopper	3
4.3. Cappuccinatore assembly	2	7.7. Coffee boiler and steam boiler	4
4.4. Discharge valve	3	7.8. Boiler pin	4
4.5. Coffee cycle	4	7.9. Coffee pump and steam pump	4
4.6. Single Microswitch	5	7.10. Turbine	5
4.7. Temperature sensor	5		

All parts included in this document are property of Saeco International Group

All rights reserved. The company waives all liability for any damages arising out of any errors or omissions in this document and the information contained herein, and no part of this document can be copied, used or noted down without a written authorisation or a specific contractual clause.

<b>Contents</b>	<b>Page</b>
7.11. Gearbox	5
7.12. Discharge valve	6
7.13. Solenoid valves assembly	6
7.14. Steam tube assembly	7
7.15. Dispenser assembly	7
7.16. Power Card	7
7.17. Display, keypads and CPU board	8
7.18. Assembly and disassembly of Oetiker clamps	8
7.19. Connection to the water supply system	9
<b>8. Notes</b>	
<b>9. Hydraulic diagram</b>	
<b>10. Electric diagram</b>	



# CHAPTER 1

## INTRODUCTION

### 1.1. Required documentation

For repairs, the following documents are necessary:

- User manual for the specific model
- Technical documents for the specific model (diagrams, exploded drawings)

### 1.2. Necessary tools and equipment

Besides the standard equipment, the following tools are also necessary:

Qty	Description	Notes
1	Screwdriver	Torx T 8 - T 10 - T 20
1	Screwdriver	Phillips head
1	Oetiker clamp pliers	
1	DC - A - Vdc tester	
1	Digital thermometer	End of scale >150°C
1	SSC (Saeco Service Center)	Programmer
		(for programming and diagnostic mode)

### 1.3. Materials

Description	Notes
Thermal paste	Thermal resistance > 200°C
Descaler	Saeco Descaler
Degreaser	Customer choice
Silicone grease	Food grade

### 1.4. Safety cautions

We strongly suggest to consult the machine's technical manual before working on it. Compliance with all the relevant regulations for the servicing of appliances is required.

Unplug the machine before starting repairs.

**Disconnecting the main switch alone is insufficient to avoid electrical discharges.**

The following appliance is rated Insulation class I.

after the repairs have been completed, the appliance needs to be tested for insulation and dielectric strength.

### 1.5. Aulika range



	Aulika	Aulika Mains
Display interface	<b>X</b>	<b>X</b>
Satin-finished steel details	<b>X</b>	<b>X</b>
ABS details	<b>X</b>	<b>X</b>
Removable Cappuccinatore	<b>X</b>	<b>X</b>
Stored dispensed coffee quantity	<b>X</b>	<b>X</b>
Stored dispensed milk quantity	<b>X</b>	<b>X</b>
Automatic shutdown (after 30' of inactivity)	<b>X</b>	<b>X</b>
Automatic descaling cycle	<b>X</b>	<b>X</b>
Connection to the water supply system		<b>X</b>
Conical steel burrs	<b>X</b>	<b>X</b>

**1.6. Componenti macchina esterni**

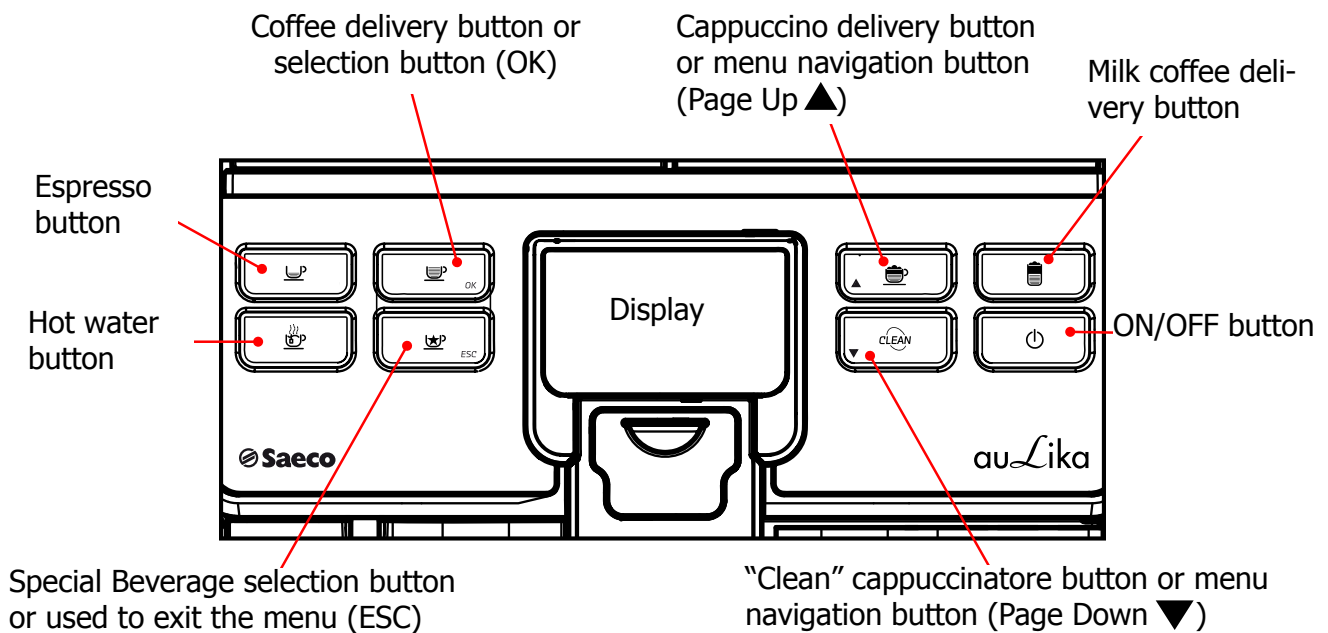
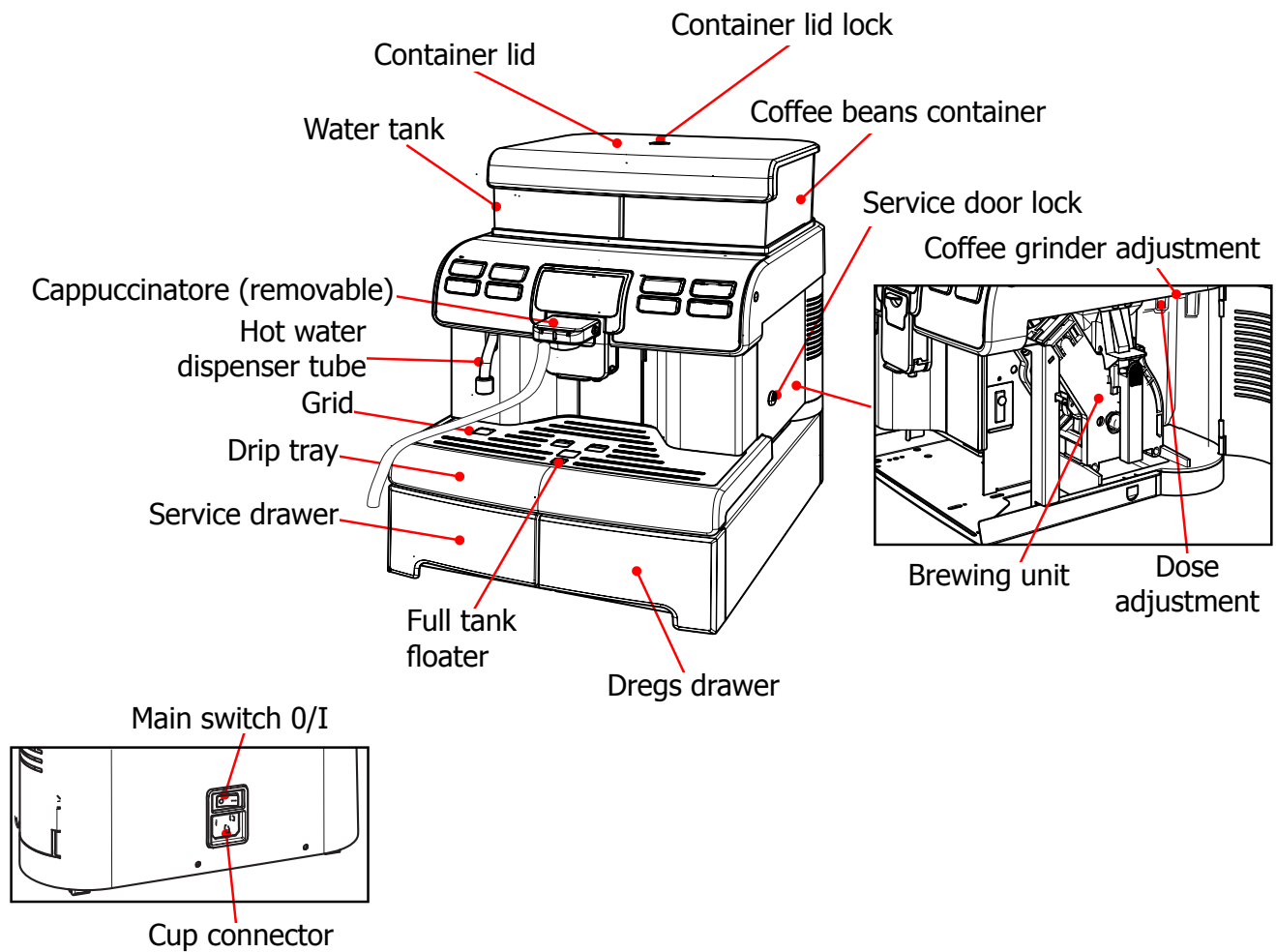

### 1.7. Machine internal hardware

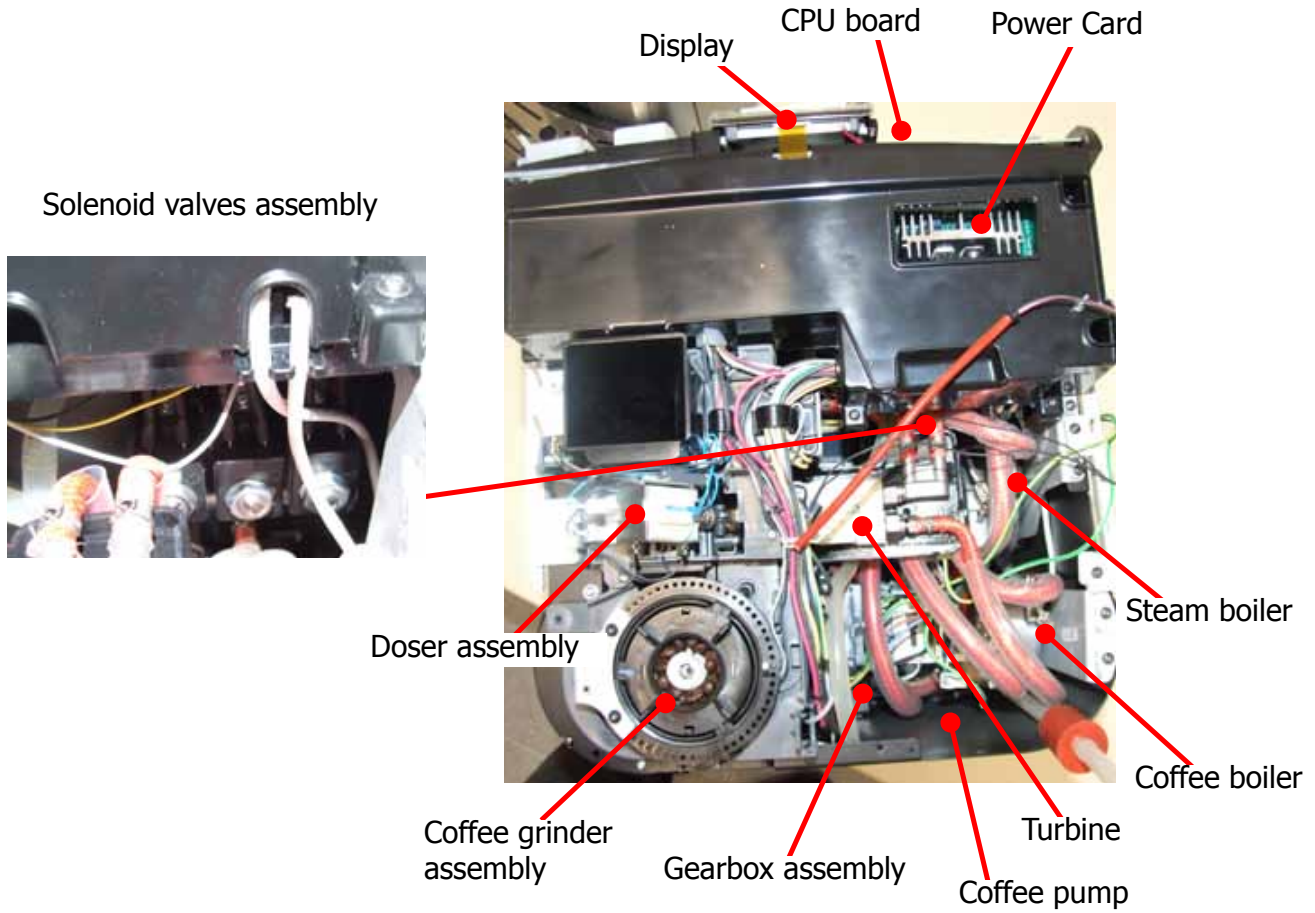



# CHAPTER 2

# TECHNICAL DATA

**2.1. Technical data**

Power supply and absorption power	240 V~ 50 Hz 1500 W - 230 V~ 50/60 Hz 1400 W
Temperature control:	Variable resistance sensors (NTC) sends the values to the electronic card
Safety cautions:	2 thermostats one shot at 190°C
Coffee heat exchanger power: Stainless steel	(230 V~) 1300 W for coffee delivery
Steam heat exchanger power: Stainless steel	230 V~) 1300 W for water/steam delivery
Gearbox:	2 rotation directions 24VC power supply
Coffee pump	Ulka Type EP5/S GW ca. 13-15 bar reciprocating with thermal 120°C 48 W, 230V, 50 Hz,
Steam pump	Ulka HF reciprocating 230V, 50 Hz with thermal 120°C - 22W
Excess pressure valve: (multiple-way valve)	Opens at ca. 19-23 bar
Water connections (only the version connected to the water supply system)	maximum pressure 8 bar minimum pressure 1.5 bar
Water filter:	In the tank
Coffee grinder:	DC motor with conical steel burrs
Absorption:	In the heating phase - ca. 5.6 A
Absorption in Stand-BY	< 0,3 W
Measurements: l x h x d in mm	336 x 555 x 450 mm
Weight:	23 kg
Water tank capacity:	4 l.
Coffee container capacity	1000 gr beans
Grounds capacity	40
Heat exchanger capacity:	Ca. 10 cc
Water circuit charging time:	Ca. 50 sec. max upon first charging, including rinsing
Heating time:	Ca. 25 sec. max in stand-by
Delivery temperature:	Ca. 75°± 5°
Grinding time:	ca. 4 - 7 sec.

## 2.2. Machine behaviour and parameters

<b>Default menu values</b>	
<b>1. CREDIT MENU</b>	
1.1 Add Credit	
1.2 Clear Credit (OK/ESC)	
1.3 Display Credit = OFF	
1.4 Check Credit = OFF	
<b>2. DRINK MENU</b>	
<b>2.1. Espresso</b>	<b>2.6. Special drinks *</b>
2.1.1. Pre-infusion = Low	<b>2.6.1. Caffè lungo</b>
2.1.2. Coffee temperature = Normal	2.6.1.1. Pre-infusion = Low
2.1.3. Coffee quantity = 35 g	2.6.1.2 Coffee temperature = Normal
2.1.4. Default (OK/ESC)	2.6.1.3. Coffee quantity = 130 g
<b>2.2. Coffee</b>	2.6.1.4. Default (OK/ESC)
2.2.1. Pre-infusion = Low	<b>2.6.2. Hot milk</b>
2.2.2. Coffee temperature = Normal	2.6.2.1. Milk quantity = 25 sec
2.2.3. Coffee quantity = 70 g	2.6.2.2. Default (OK/ESC)
2.2.4. Default (OK/ESC)	<b>2.6.3. American Coffee</b>
<b>2.3. Cappuccino</b>	2.6.3.1. Coffee temperature = Normal
2.3.1. Pre-infusion = Low	2.6.3.2. Coffee quantity = 235 g
2.3.2. Coffee temperature = Normal	2.6.3.3. Default (OK/ESC)
2.3.3. Coffee quantity = 40 g	<b>2.7. Counters</b>
2.3.4. Milk quantity = 19.5 sec	2.7.1. Espresso = 0
2.3.5. Default (OK/ESC)	2.7.2. Coffee = 0
<b>2.4. Milk coffee</b>	2.7.3. Lungo = 0
2.4.1. Pre-infusion = Low	2.7.4. American Coffee = 0
2.4.2. Coffee temperature = Normal	2.7.5. Hot water = 0
2.4.3. Coffee quantity = 70 g	2.7.6. Cappuccino = 0
2.4.4. Milk quantity = 22 sec	2.7.7. Milk coffee = 0
2.4.5. Default (OK/ESC)	2.7.8. Hot Milk = 0
<b>2.5. Hot water</b>	2.7.9. Reset counters (OK/ESC)
2.5.1. Water quantity = 280 g	
2.5.2. Default (OK/ESC)	

**\*Activating this includes steam**

**3. MACHINE MENU**

<b>3.1 General menu</b>	<b>3.3. Water menu</b>
3.1.1. Sound = ON	3.3.1. Hardness = 4
3.1.2. Ecomode = ON	3.3.2. Filter enabl. = OFF
3.1.3. Stand-by sett. = 30 min	3.3.3. Filter Activ. (OK/ESC)
3.1.4. Self learning = OFF	3.3.4. Water mains = OFF
3.1.5. Set password	<b>3.4 Maintenance</b>
<b>3.2 Display menu</b>	3.4.1. Assembly cleaning (OK/ESC)
3.2.1. Language = Italian	3.4.2.1. Start Descaling (OK/ESC)
3.2.2. Brightness = 8th graphic level	3.4.2.2. Descaling warning = OFF
3.2.3. Contrast = 8th graphic level	<b>3.4.3. Cappuccinatore cleaning</b>
	3.4.3.1. Start Cleaning (OK/ESC)
	3.4.3.2. Cleaning warning = ON
	<b>3.5 Factory settings (OK/ESC)</b>

PRODUCTS QUANTITY	Minim. quantity (Sett.)	Default quantity (Sett.)	Maxim. quantity (Sett.)	User programming	Production/Service programming
<b>Espresso</b>	90	130 - 170 *	200	Yes	No
<b>Coffee</b>	100	200 -280*	600	Yes	No
<b>Caffè lungo</b>	70	330 - 440 *	600	Yes	No
<b>American Coffee</b>	300	-	600	Yes	No
<b>Pre-ground</b>	No				
<b>Hot water</b>	Continues for 400 pulses				

\* Dipende dalla lingua selezionata dall'utente

STAND-BY	Description and values
<b>Start-up time (min - max)</b>	15 minutes - 180 minutes
<b>Start-up time (default)</b>	30 minutes
<b>User-programmed start-up time</b>	Yes
<b>Production/Service-programmed start-up time</b>	Yes
<b>Boiler temperature in stand-by</b>	Boiler OFF

<b>RINSE</b>	<b>Initial rinse</b>	<b>Final rinse</b>
When it occurs	When the machine is turned on and the boiler temperature is $\leq 50^{\circ}\text{C}$	When the machine is turned off electronically, manually by the user or automatically after 30', provided that at least one coffee has been dispensed prior to the turning off.
N° of pulses	130	100
Stoppable	Yes, by pressing any key	Yes, by pressing any key
Can be disabled by the user	No	No
Can be disabled by Production/Service	No	No
User-adjustable N° of pulses	No	No
N° of pulses adjustable by Production/Service	No	No
Pulses range (Min - Max)	No	No

<b>GROUND'S DRAWER</b>	<b>Description and values</b>
<b>Time-out on the grounds drawer</b>	5 sec.
<b>Empty grounds drawer warning after</b>	After 37 grounds
<b>Empty grounds drawer locking alarm after</b>	40 grounds
<b>(double coffee as the last product delivered)</b>	(41 grounds)
<b>Grounds counter reset</b>	Only in the presence of a warning or of the alarm, provided that the drawer is removed for at least 5 sec.

<b>WATER TANK</b>	<b>Description</b>
<b>Water reserve (pulses)</b>	200
<b>Water reserve adjustable by Production/Service</b>	No
<b>"Fill tank" alarm</b>	Yes
<b>"Tank absent" alarm</b>	No
<b>Water mains</b>	No

<b>Descaling intervals</b>			
<b>Hardness</b>	<b>Water hardness</b>	<b>Senza filtro anticalcare</b>	<b>Con filtro anticalcare</b>
<b>1</b>	Soft (up to 7°dH)	240 litres (480,000 pulses)	480 litres (960,000 pulses)
<b>2</b>	Medium (7°-14dH)	120 litres (240,000 pulses)	240 litres (480,000 pulses)
<b>3</b>	Hard (15°-21°dH)	60 litres (120,000 pulses)	120 litres (240,000 pulses)
<b>4</b>	Very hard (above 21°dH)	30 litres (60,000 pulses)	60 litres (120,000 pulses)

The default water hardness is 4. A litre of water corresponds to about 2,000 pulses.



# CHAPTER 3

# USER GUIDE

### 3.1. Machine warnings



In order for the machine to operate, close the service door

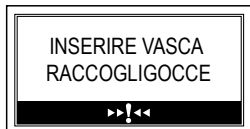

Insert drip tray



Insert grounds drawer



Close or position correctly the coffee beans container lid in order for the machine to dispense any beverage.



Extract the tank and fill it with fresh drinking water



Place the brewing unit in its seat.



The selected operation requires the delivery of milk. Place the cappuccinatore on the machine as shown in the manual.



The selected operation requires the delivery of milk. Insert the previously removed valve back in the cappuccinatore, as specified in the manual.



Fill the coffee contained with beans.

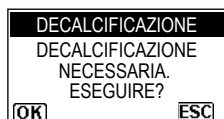

If this message is displayed after starting the machine, this means that a descaling cycle needs to be performed. Contact the operator. Please remember that damage caused by no descaling is not covered by the warranty.



The machine requests a descaling cycle. When this message appears, the machine can be used but its performance can be compromised. Please remember that damage caused by no descaling is not covered by the warranty.



The machine asks for the replacement of the "Intenza" water filter. Please replace the filter. This alarm is displayed only if the "Enable Filter" function is ON.

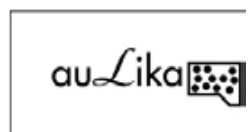

The machine signals that in a few cycles the grounds drawer shall need to be emptied. It is still possible to deliver some products.



Remove the grounds drawer and empty the grounds into an appropriate container. Note: the grounds drawer must be emptied only when the machine requests it and with the machine on. If the drawer is emptied while the machine is off, the machine cannot record this operation.

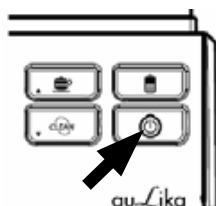

Blinking red led Machine in Stand-By. It is possible to modify the Stand-By settings (please contact the operator).



An event that requires the machine to be restarted has occurred. Please note down the code (E xx) displayed at the bottom. Turn the machine off and turn it back on again after 30 seconds. If the problem persists, call the service centre.

### 3.2. Operator guide

To enter the menu, turn the machine back on and press the following keys in sequence

- Cappuccino
- Stand-By
- Milk coffee
- Clean

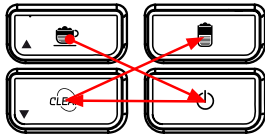

If the sequence is correct, the programming menu is accessed.

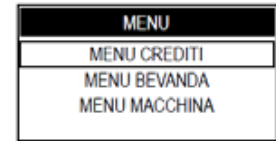

**Menus must be PASSWORD-protected.**

**The PASSWORD is not requested if it is set to the default value (0000). The password must be changed upon first starting the machine, so as to prevent access by unauthorised staff.**

#### PASSWORD SETTING

The PASSWORD shall be set by the operator, so as to prevent access by unauthorised staff, who might change the settings of the machine and cause its malfunction.

Follow these steps to set the PASSWORD:

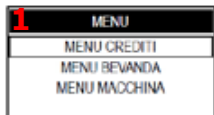

**1** Access the programming menu of the machine

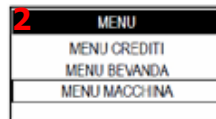

**2** To select "MACHINE MENU" press the Clean key



**3** Press the "☕" key to enter.

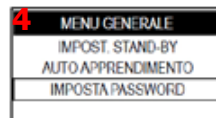

**4** Press the "☕" key to enter the "GENERAL MENU"



**5** To select "SET PASSWORD" press the Clean key.  
Press the "☕" key to enter.

**6** Now it is possible to set the desired PASSWORD

**7** Press the "Clean" key or the "☕" key to enter the desired number.

**8** Press the "☕" key to confirm the shown number and proceed to the next setting.

**9** Repeat procedures (7) and (8) to set all the chosen numbers.

**CREDIT MENU** This menu makes it possible to manage credit so as to avoid the delivery of the wrong product. Credit management does not work for hot water, hot milk and steam delivery.

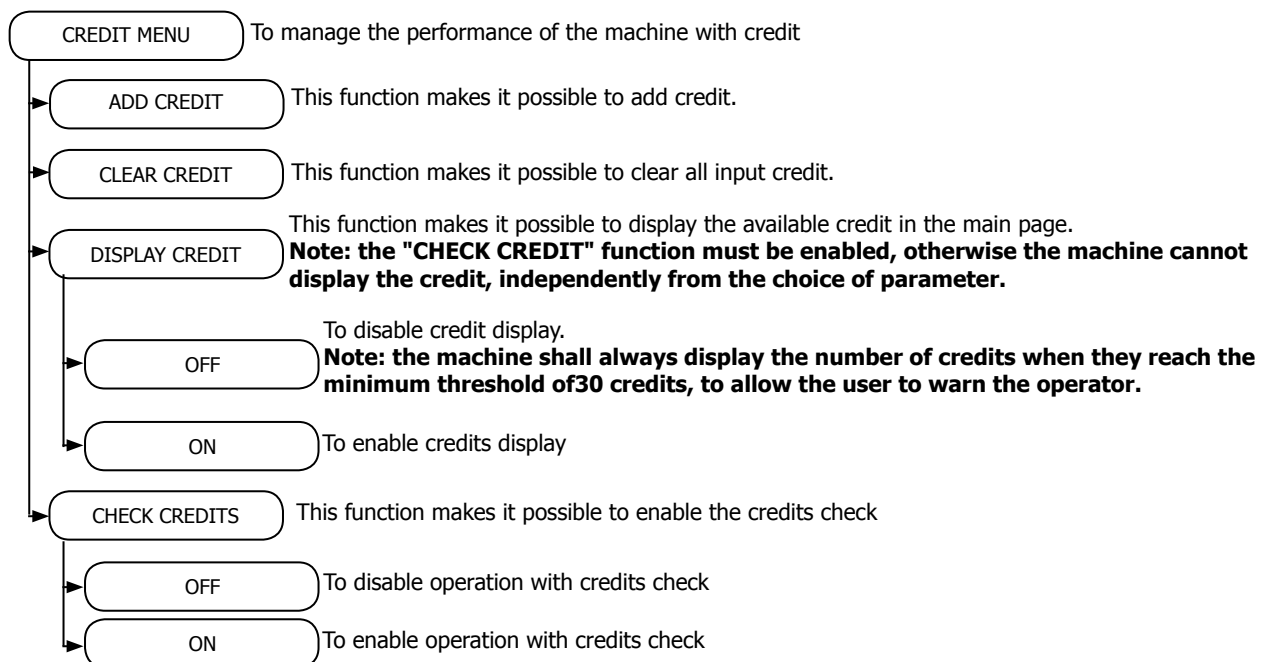

**BEVERAGES MENU** This menu makes it possible to manage and customise the settings for each beverage

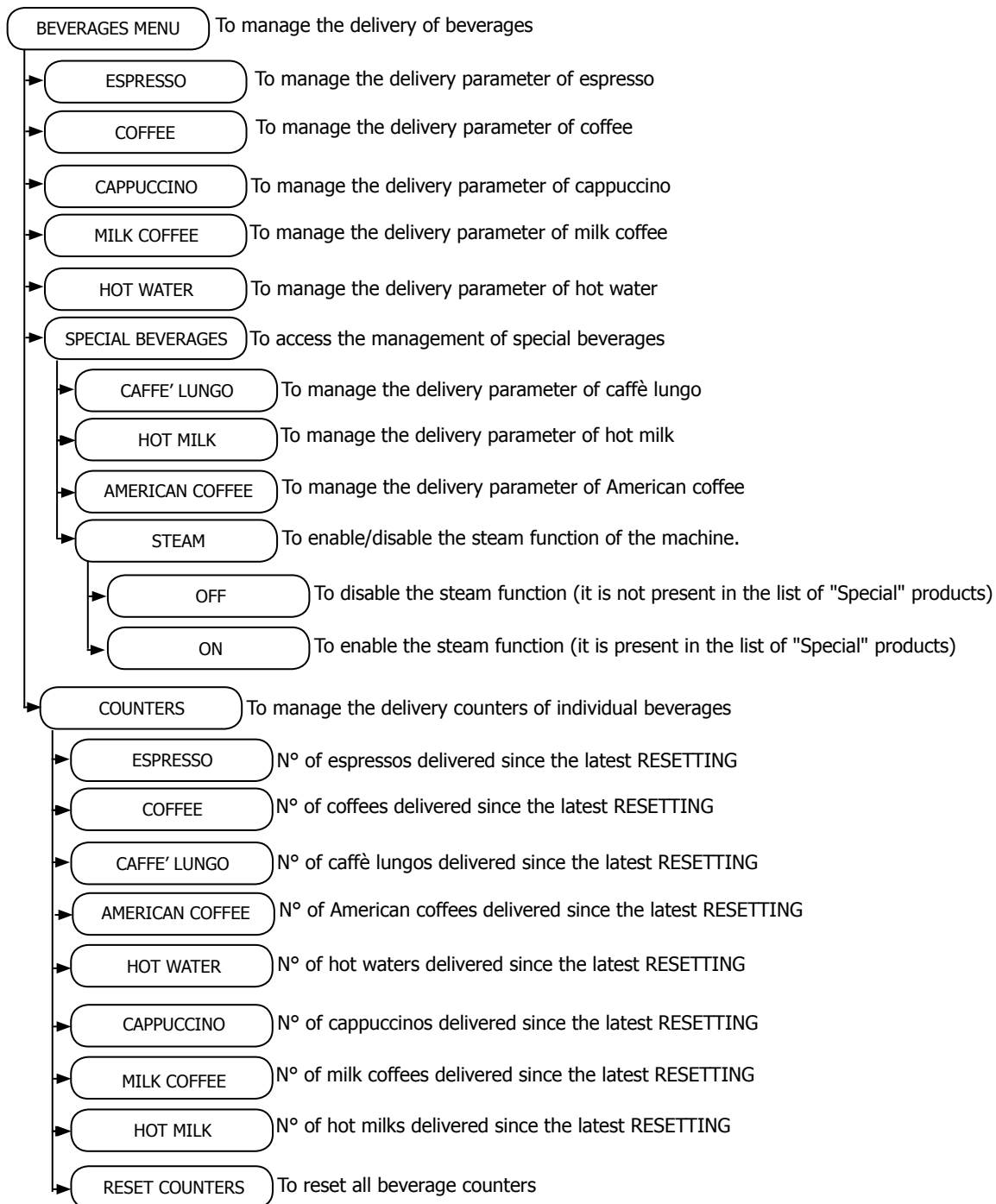

## BEVERAGE PARAMETERS

This paragraph describes the various parameters that can be changes.

**Note: not all parameters are present for all programmable items.**

### PRE-INFUSION

Pre-infusion: coffee is wet before infusion, so as to highlight the full aroma of coffee, with excellent results. OFF: pre-infusion does not occur.  
LOW: enabled HIGH: longer, to enhance the taste of coffee.

### MILK QUANTITY

This section can be used to program the quantity of milk delivered every time the beverage is selected. The bar makes it possible to fine-tune the quantity of milk to be used **(unit of measure in seconds)**.  
**These settings are valid only to program the delivery of beverages containing milk.**

### COFFEE TEMPERATURE

This section can be used to program the coffee brewing temperature.  
LOW: low temperature  
NORMAL: standard temperature  
HIGH: high temperature

### WATER QUANTITY

This section can be used to program the quantity of water delivered every time the relevant key is pressed. The bar makes it possible to fine-tune the quantity of water to be used **(unit of measure in turbine pulses)**.  
**These settings are valid only to program the delivery of Hot water.**

### COFFEE LENGTH

This section can be used to program the quantity of coffee delivered every time the beverage is selected. The bar makes it possible to fine-tune the quantity of coffee to be used **(unit of measure in turbine pulses)**

### DEFAULT

For every beverage, it is possible to go back to the default settings, also according to the language selected.  
Once this function is selected, the customised settings for that beverage are deleted.

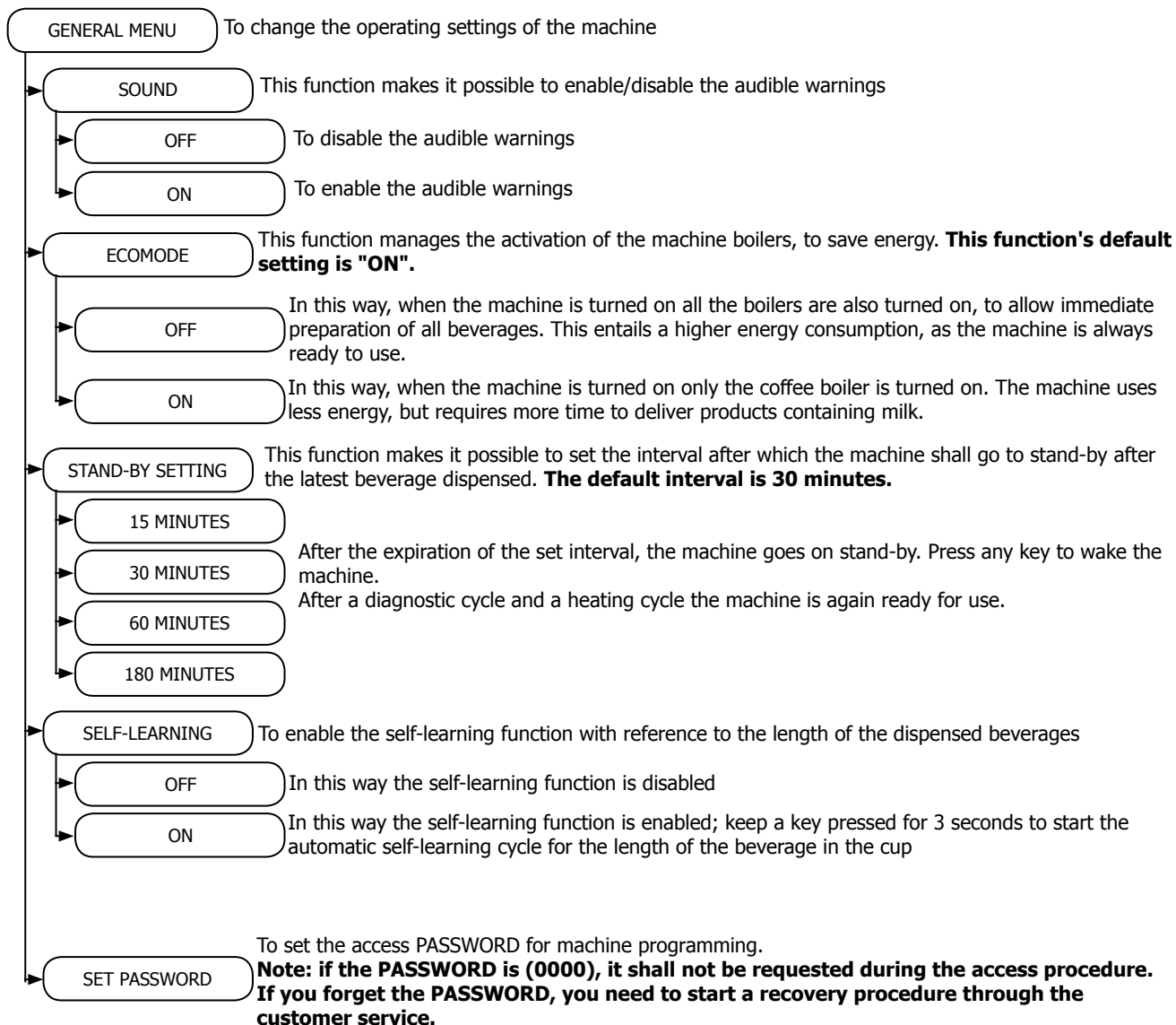
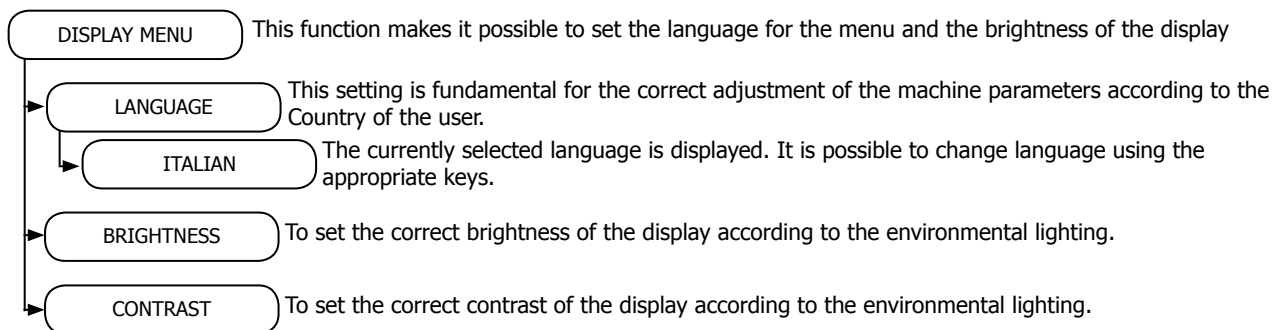
**MACHINE MENU** Makes it possible to customise the machine functions settings**DISPLAY MENU**

## WATER MENU

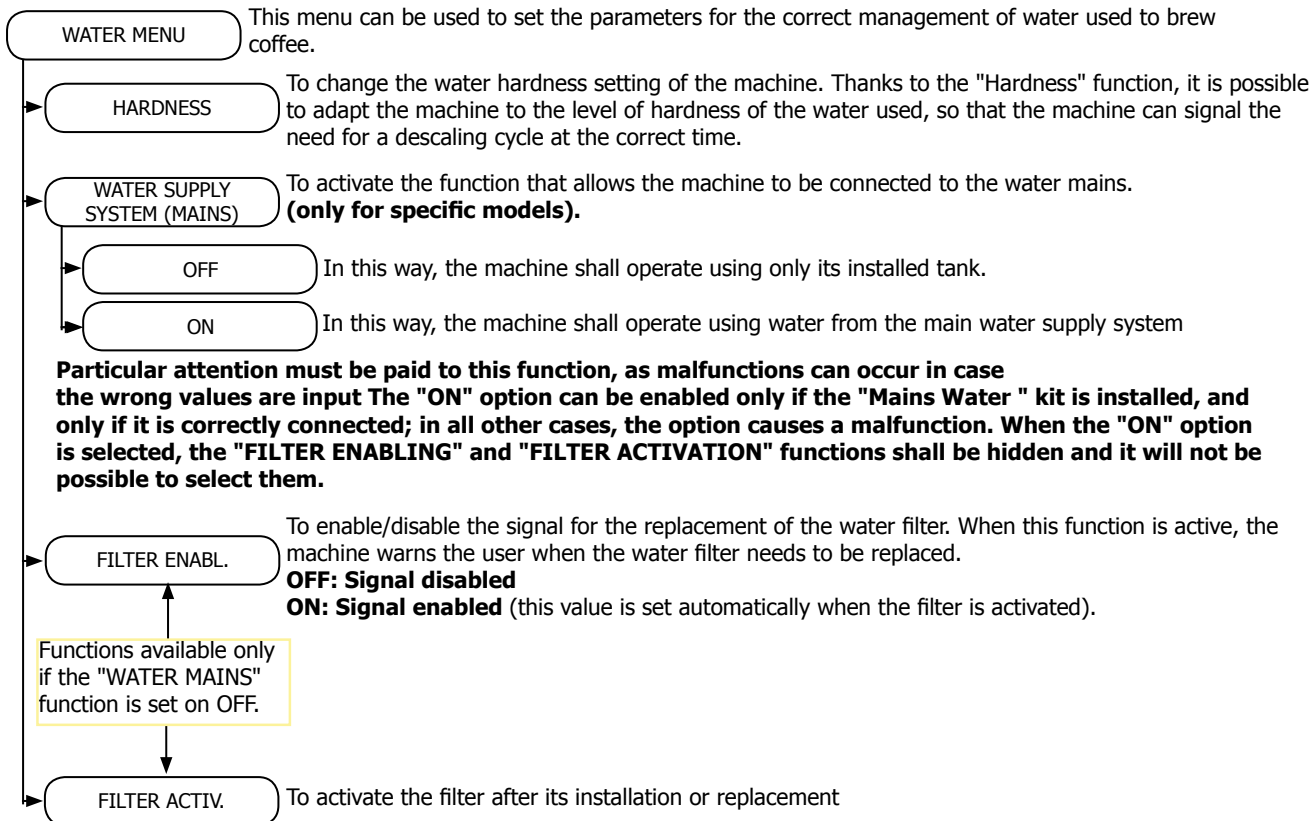

## MAINTENANCE

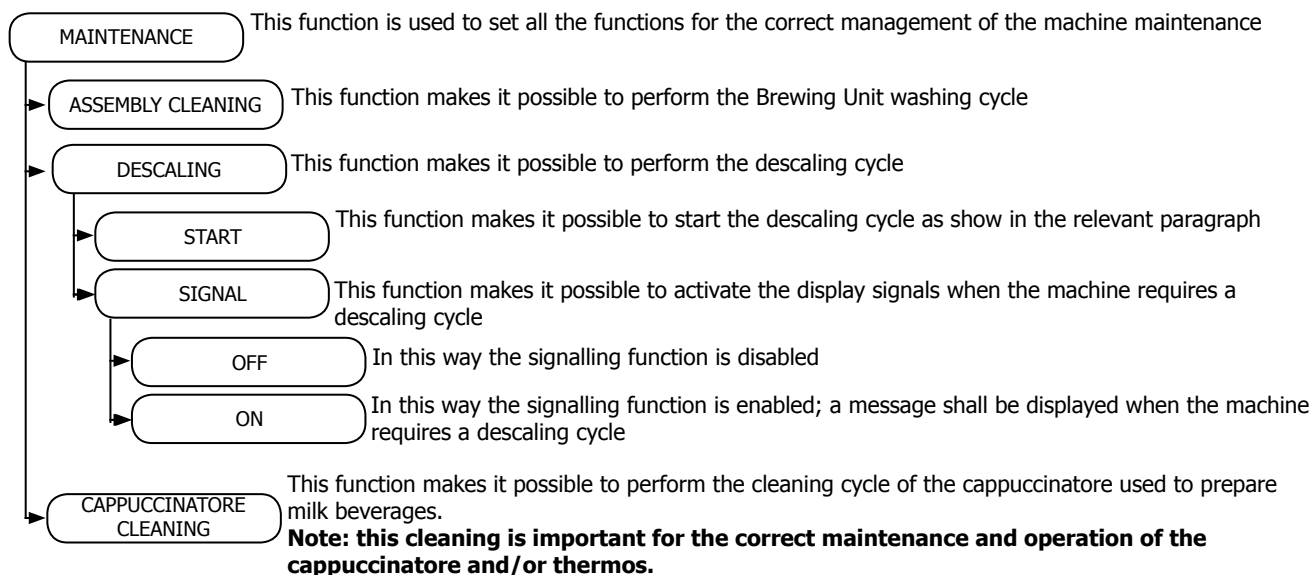

## FACTORY SETTINGS

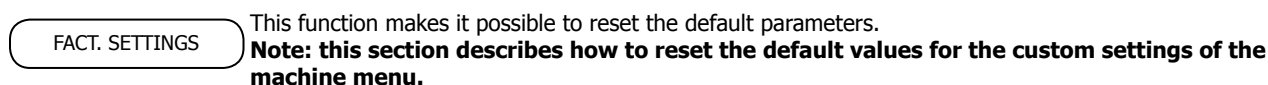

### 3.3. Operation, cleaning and maintenance

Operation		
1	Fill the water tank	
2	Fill the coffee container with beans.	
3	Turn the machine on	
4	Press the key to start the machine	
5	Select the desired language	Save it
6	Heating	The heating phase starts, please wait until it is completed.
7	Rinse	The machine performs a rinsing cycle on the internal circuits.
8	Machine ready	The machine is ready to deliver its products.

CLEANING AND TECHNICAL ASSISTANCE		
A	Empty the grounds drawer	If the signal is on
B	Empty the drip tray	If needed (floaters)
C	Clean the water tank	Once a week
D	Clean the coffee beans container.	If needed
E	Clean the chassis	If needed
F	Clean the brewing unit	Every time the beans are refilled or once a week.
	Lubricate the brewing unit	After 500 deliveries
	Brewing unit seat cleaning	Once a week
H	Descaling	If the signal is on
I	Cleaning of the cappuccinatore with a detergent	Before its return

Descaling intervals			
Hardness	Water hardness	Without water softener	With water softener
<b>1</b>	Soft (up to 7°dH)	240 litres (480,000 pulses)	480 litres (960,000 pulses)
<b>2</b>	Medium (7°-14dH)	120 litres (240,000 pulses)	240 litres (480,000 pulses)
<b>3</b>	Hard (15°-21°dH)	60 litres (120,000 pulses)	120 litres (240,000 pulses)
<b>4</b>	Very hard (above 21°dH)	30 litres (60,000 pulses)	60 litres (120,000 pulses)

The default water hardness is 4. A litre of water corresponds to about 2,000 pulses.



# CHAPTER 4

# OPERATING LOGIC

4.1. Hydraulic Circuit

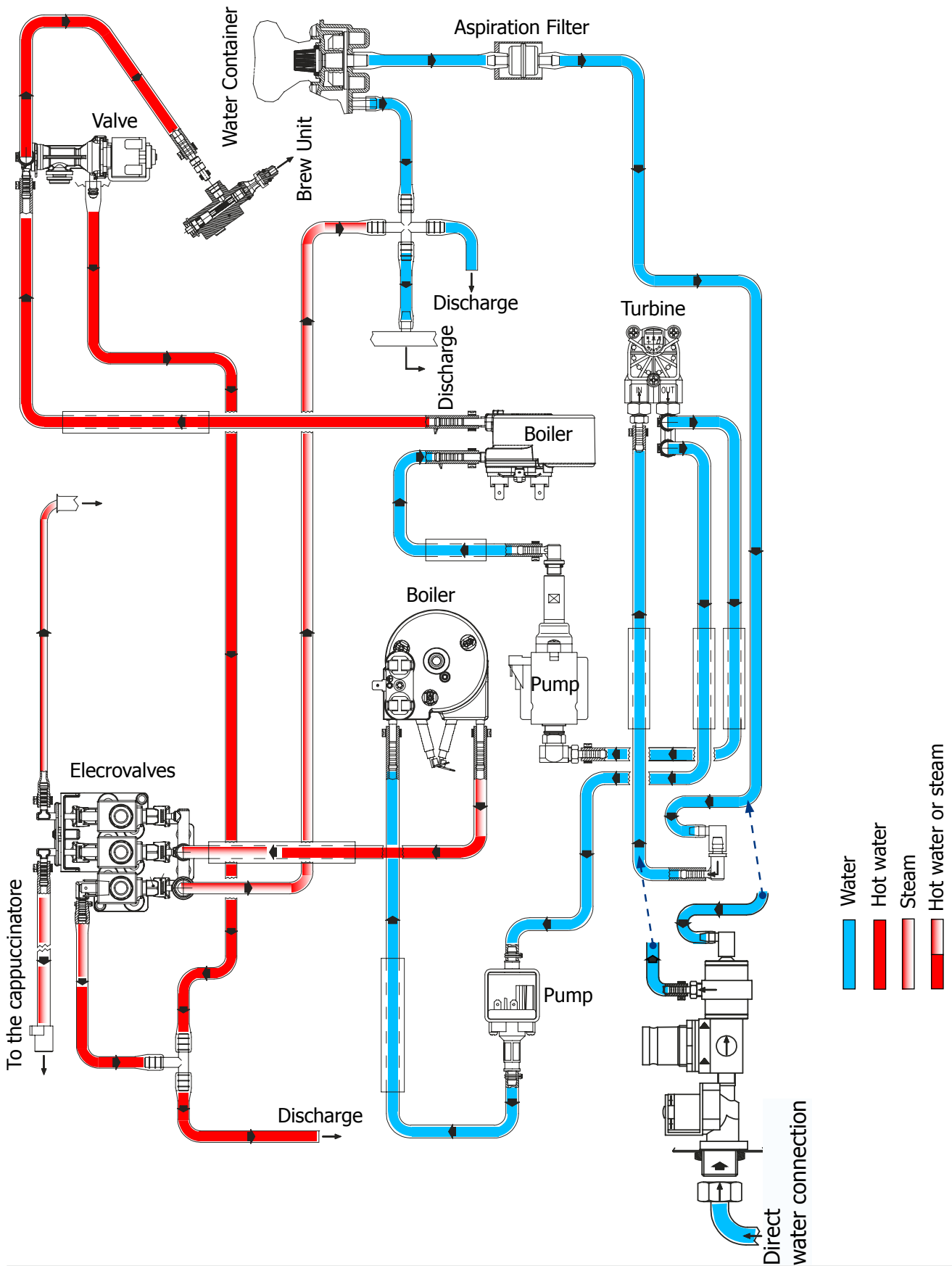

### 4.2. Emulsifier valve assembly

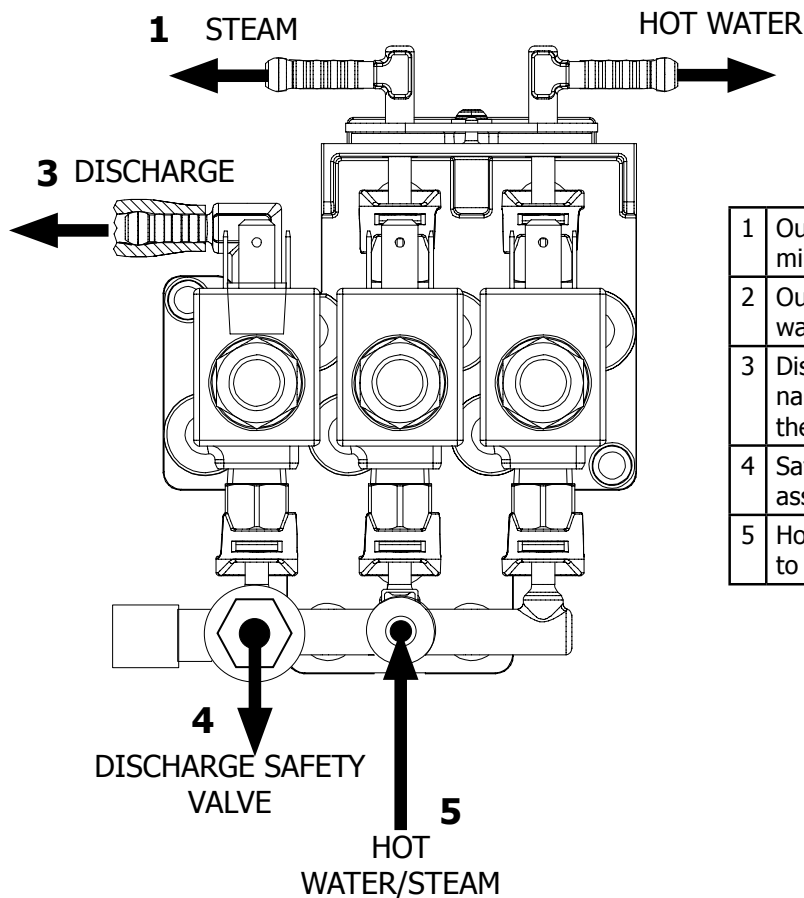

1	Output to the cappuccinatore for milk products
2	Output to the steam tube, only hot water is dispensed
3	Discharge used to reduce the internal pressure in the conduits when the product ends
4	Safety valve protecting the valve assembly
5	Hot water or steam inlet, according to the product to be delivered

### 4.3. Cappuccinatore assembly

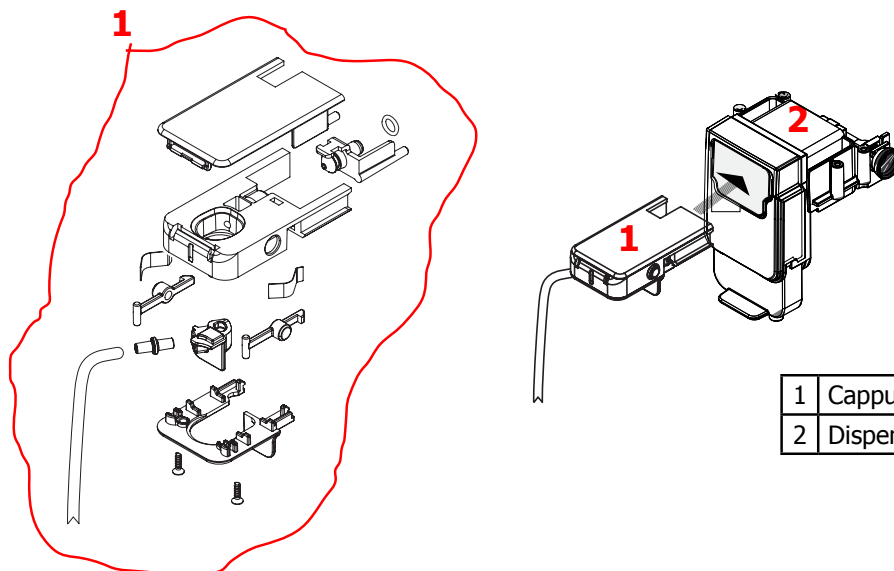

1	Cappuccinatore assembly
2	Dispenser assembly

#### 4.4. Discharge valve

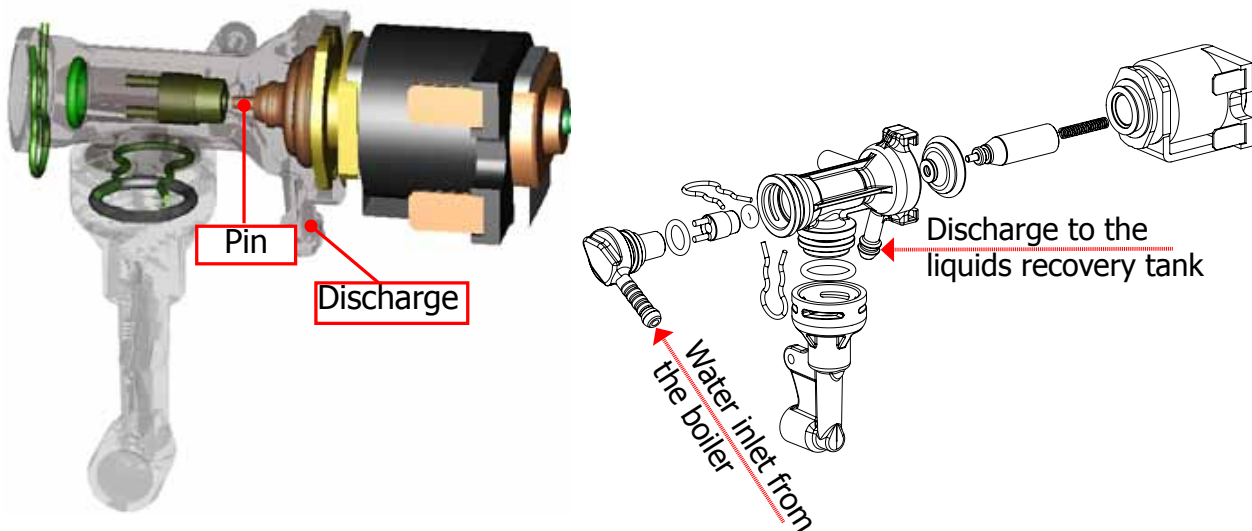

##### Functions:

**Safety valve:** serves as safety valve by opening towards the discharge when the pressure exceeds 16-19 bar.

**Circuit charging:** the solenoid valve opens (discharge position), the pump is activated and automatically recharges the circuit, discharging any air out of the conduit.

**Assembly discharge:** before the assembly comes down, it opens briefly to discharge the accumulated pressure and avoiding spraying from the assembly and keeping the plug nut drier

**Coffee product:** when a coffee product is selected, the pump briefly charges during the grinding phase, the valve goes into discharge mode to bring hot water back into the conduits.

## 4.5. Coffee Cycle

Main switch ON	START		END
Time			
Coffee grinder			Pulses (Dosing)
Heating	ca.45 sec.		
Pump			Pump activity (turbine pulses) based on the programmed product quantity
Gearbox Brewing unit			
Status	<b>Heating</b>	<b>Ready</b>	<b>Coffee cycle</b>

Notes: \* Only with pre-infusion



### Single micro gearbox

#### Start

When the machine starts, the gearbox gets back in place as follows:

- Microswitch 1 is activated (See following chapter)
- The gearbox changes the direction of rotation and goes back up for about 1-2 mm
- The boiler starts heating the water for ca. 45 sec, absorbing the whole of the heating power to attain the optimal temperature. After that, the temperature shall remain constant.

#### Ciclo caffè

1. The coffee grinder starts grinding the beans (managed by the doser microswitch)
2. The doser opens
3. The gearbox (brewing unit) goes into dispensing mode
4. Preliminary dispensing phase (brief activity of the pump, then a brief pause)
5. Product delivery (the pump activation time depends on the quantity of product delivered)
6. The gearbox goes back to the idle position (grounds are automatically expelled)

#### 4.6. Single Microswitch

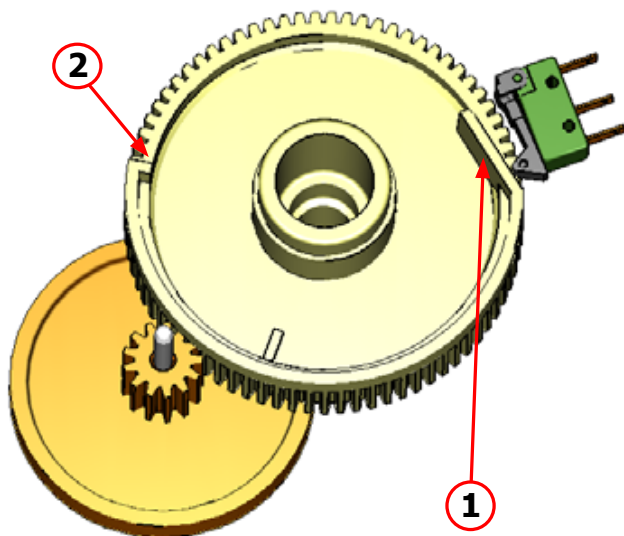

The gearbox is operated by a direct current motor that acts on the smallest double toothed wheel through a worm screw. The assembly is mounted on the axle of a large toothed wheel and, when a request for coffee must be addressed from idle mode, it moves to the delivery position and then goes back to the idling position.

- **Idling position: 1**

- **Delivery position: 2**

#### 4.7. Temperature sensor (adjustment)

Temp. (° C)	R nom (kΩ)	ΔR (+/- %)
20	61,465	8,6
50	17,599	5,9
75	7,214	4,1
80	6,121	3,7
85	5,213	3,4
90	4,459	3,1
100	3,3	2,5
125	1,653	3,9
150	0,893	5,1

The temperature sensor is an NTC which, in case of excess temperatures, reduces the resistance absorption.

The electronics recognises and regulates the actual temperature of the boiler through a voltage reduction.

**Resistance values and their corresponding temperatures:** see table

#### 4.8. Water level detection (water tank)

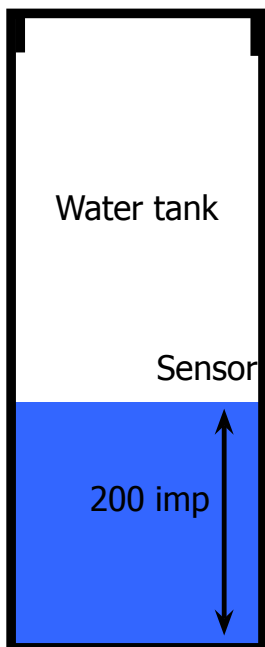

##### Lack of water alarm (water reserve)

###### Function:

The water level is monitored by a capacitive sensor placed one third from the bottom of the tank. If the sensor records a lack of water in the tank at its level, this means that a water reserve of about 200 turbine pulses is still available for the product being currently prepared. After this, the product is delivered.

If a delivery ends after the sensor has been triggered (using the reserve), the "water empty" signal continues to be displayed through the next delivery.

#### 4.9. Descaling request

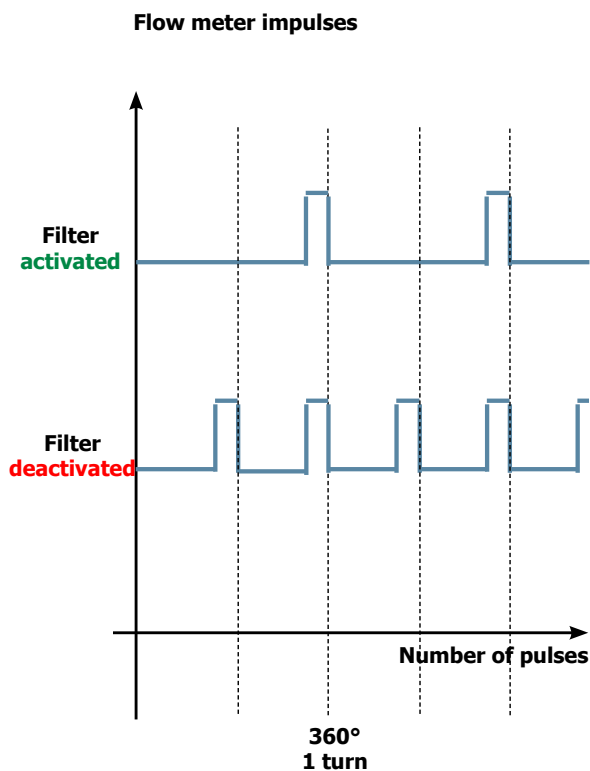

##### Descaling warning with water softener (only for models equipped with a display)

Water hardness is regulated on the basis of the analysis of regional hardness (1, 2, 3, 4).

###### Filter deactivated:

If this function is **deactivated** the electronic controller counts the turbine pulses and records **one pulse for each turn**.

###### Filter activated:

If this function is **activated** the electronic controller counts the turbine pulses and records **one pulse every two turns**.

###### Replace water softener signal.

Through the counting of the turbine pulses, the electronic controller measures the quantity of water that has flowed through, and triggers the "Replace water softener" signal after the number of litres preset on the basis of water hardness has been reached.

## 4.10. Water softener

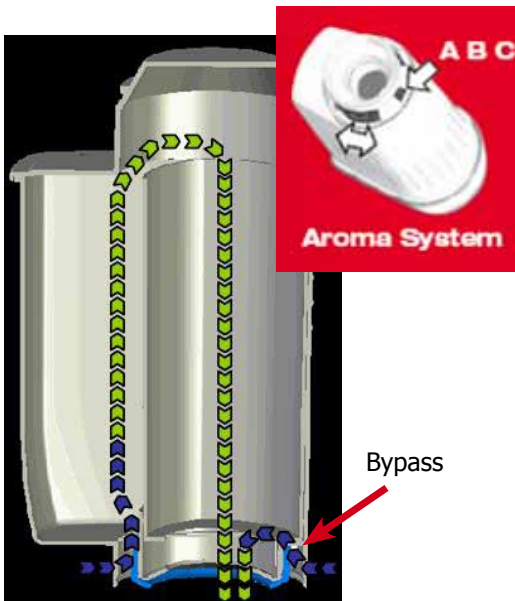

### Water softener

#### Function:

- Reduction of and delay in the formation of limescale deposits.
- Water quality improvement.
- Taste improvement by finding the ideal water hardness

#### Duration / results of descaling:

- - 10 ° dH
- 60 litres
- 2 months

In order for the operation to be as uniformly effective as possible for the whole period, water is made to flow through a three-phase (A,B,C) bypass, according to the level of hardness. See small pictur.



# CHAPTER 5

# FAULT FINDING

## 5.1. Test mode

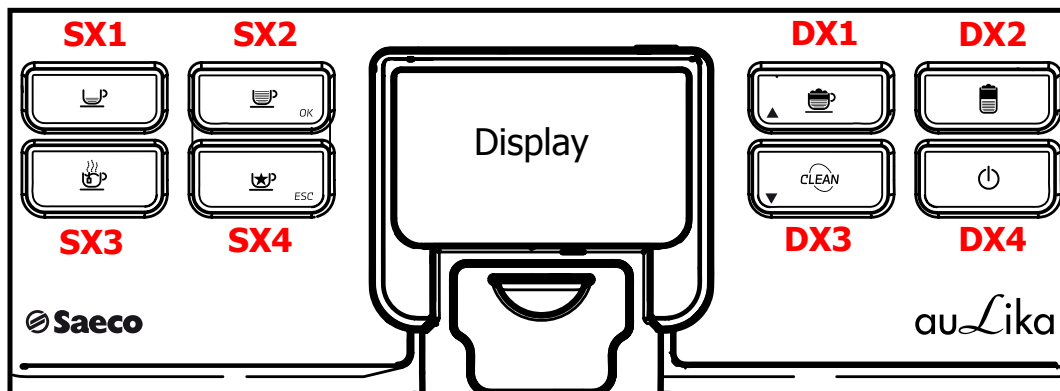

KEY	MAIN FUNCTION	SECONDARY FUNCTION
SX1	Espresso	
SX2	Coffee	
SX3	Hot water	
SX4	Access to the Special menu	
DX1	Cappuccino	Next page of the Test Mode menu
DX2	Milk coffee	
DX3	Cleaning cycle	Previous page of the Test Mode menu
DX4	Access while in Stand-by	Exit the Test Mode from page 1

### To access the Test Mode:

- Turn on the machine
- Press the four function keys in sequence (**SX4, SX1, SX2, SX3**) before the initialization bar is complete.

The Test Mode pages all have the following structure:

Title			
SX1	SX2	DX1	DX2
SX3	SX4	DX3	DX4
Info1	Info2	Info3	
Info4	Info5	Info6	Info7

- The names of the loads that can be activated with the keys shown in each sector are displayed in **yellow**.
- The sectors that provide information on the status of the sensors are displayed in **green**.
- The keys DX1 (next page) and DX3 (previous page) are shown in **white**.

Thus loads can be activated by the relevant keys SX1, SX2, SX3, SX4 from the left keypad, or by the DX2, DX4 keys from the right keypad.

**On page 2 Brew Unit there is an exception to this rule, as SX4 displays the status of a sensor, not a load that can be activated.**

## Description of the individual pages

## 1 Software



1 Software			
Swiss	Pow Off	△	Debug
W.Net S	W.Net A	▽	ESC
f	MV: xx	xx.yy.zz	
B2B	B2B RI	DF	ER

SECTOR	TYPE	DESCRIPTION
<b>Swiss</b>	FUNCTION	Swiss can be used to activate or deactivate the ECO-MODE default setting. If Swiss is active, the Eco-Mode default setting is ON, while if Swiss is inactive, the Eco-Mode default setting is OFF. The hydraulic circuit emptying function brings the ECO-MODE back to the default value. This default value, as already mentioned, is a function of the Swiss setting
<b>Pow Off</b>	FUNCTION	It shows whether the machine, once turned on with the electromechanical switch (I/O), goes in Stand-By mode; if so, the "Pow Off" words are highlighted. If it is deactivated, the machine does not go to Stand-By mode immediately after the Power On.
<b>W.Net S</b>	FUNCTION	If pressed, this key enables/disables the water net system function (if it is active, then the machine is model B2B RI, if it is inactive, then the model is B2B).
<b>W.Net A</b>	FUNCTION	If pressed, it operates the 24VDC solenoid valve of the water network system (actual activation occurs only if: - the grounds drawer and the brew unit niche drawer are assembled and the side door is closed)
<b>Debug</b>	FUNCTION	If selected, a debug window opens in user mode
<b>ESC</b>	FUNCTION	If pressed, the machine exits Test Mode
<b>f</b>	INFO	Shows the network frequency. It can take the following values: 50 Hz 60 Hz ERR when the frequency cannot be identified
<b>MV: xx</b>	INFO	shows the EEPROM Memory version
<b>xx.yy.zz</b>	INFO	shows the version of the loaded software
<b>B2B</b>	INFO	If active, it shows that the machine version is B2B
<b>B2B RI</b>	INFO	If active, it shows that the machine version is B2B connected to the water supply system.
<b>DF</b>	INFO	Gives information of the status of the memory This value must be 64
<b>ER</b>	INFO	Gives information of the status of the memory This value must be 8

Press DX1 to go to the next page

## 2 Brew Unit



2 Brew Unit			
Work	Home	▲	Dreg+
Stop	m BU Dr	▼	Dreg-
dd	m Tray	mA: xxxx	
m H/W	m Door	m Dreg	m BU

SECTOR	TYPE	DESCRIPTION
<b>Work</b>	FUNCTION	If activated, it operates the gearbox to bring the brew unit in the Work position
<b>Home</b>	FUNCTION	If activated, it operates the gearbox to bring the brew unit in the Home position
<b>Stop</b>	FUNCTION	If activated, it stops the gearbox
<b>Dreg+</b>	FUNCTION	If activated, it increases the set maximum value of grounds before the alarm is triggered
<b>Dreg-</b>	FUNCTION	If activated, it decreases the set maximum value of grounds before the alarm is triggered
<b>dd</b>	INFO	It shows the current setting of maximum grounds quantity.
<b>m Tray</b>	INFO	If active, it shows that the magnetic reed sensor showing the presence of the drip tray 
<b>mA</b>	INFO	Shows the maximum power value for the unit as average value per second.
<b>m H/W</b>	INFO	If active, it shows that the Home/Work position microswitch is pressed.
<b>m Door</b>	INFO	If active, it shows that the side door microswitch is pressed. If inactive, it shows that at least one between n Door, n Dreg and m BU is inactive, or that the side door microswitch is not pressed and/or the unit drawer is not present and/or the grounds drawer is not present (to test it individually, it is necessary to insert both drawers)
<b>m BU Dr</b>	INFO	If active, it shows that the magnetic reed sensor showing the presence of the unit tray is active  the unit drawer is present. If inactive, it means that at least one between mDreg and m BU Dr is inactive or that the unit drawer is not present and/or the grounds drawer is not present (to test it individually, it is necessary to insert the grounds drawer: this deactivates m Door too)
<b>m Dreg</b>	INFO	If active, it shows that the magnetic reed sensor showing the presence of the grounds drawer is active  the drawer is present. If inactive, it shows that m Dreg is inactive, or that the grounds drawer is not present (this deactivates also m BU Dr and m Door).
<b>m BU</b>	INFO	If active, it shows that the unit presence microswitch is pressed.

Press DX1 to go to the next page

### 3 Hydraulic Circuit

3 Hydraulic Circuit			
EVsteam	EVwater	△	Pump1
EVdisch.	EVcoffee	▽	Pump2
T1 xx	T2 yy	p/s: zz	
m Capp	m Milk	m Tank	^

SECTOR	TYPE	DESCRIPTION
<b>EVsteam</b>	FUNCTION	If activated, it operates the 24 VDC solenoid valve of the steam circuit (actual activation occurs only if: - the grounds drawer and the brew unit niche drawer are assembled and the side door is closed)
<b>EVwater</b>	FUNCTION	If activated, it operates the 24 VDC solenoid valve of the hot water circuit (actual activation occurs only if: - the grounds drawer and the brew unit niche drawer are assembled and the side door is closed)
<b>EVdisch.</b>	FUNCTION	If activated, it operates the 24 VDC solenoid valve of the steam circuit discharge (actual activation occurs only if: - the grounds drawer and the brew unit niche drawer are assembled and the side door is closed)
<b>EVcoffee</b>	FUNCTION	If activated, it operates the 230VAC solenoid valve
<b>Pump1</b>	FUNCTION	If activated, it operates pump 1 of the coffee circuit
<b>Pump2</b>	FUNCTION	If activated, it operates pump 2 of the water/steam circuit
<b>T1</b>	INFO	Shows the temperature of the coffee boiler in °C
<b>T2</b>	INFO	Shows the temperature of the water/steam boiler in °C
<b>p/s</b>	INFO	Shows the water flow in the turbine at any moment, expressed in pulses per second. When Pump 1 (coffee pump) is turned on and the 230 V solenoid valve (EVcoffee) is activated the value cannot be lower than 12p/sec. When Pump 2 (water&steam pump 2) is turned on and the discharge solenoid valve (EVdisch) is activated the value cannot be lower than 8p/sec.
<b>m Capp</b>	INFO	shows the status of the presence of the cappuccinatore unit  if turned on it is active
<b>m Milk</b>	INFO	shows the status of the presence of the milk valve in the cappuccinatore unit  if turned on it is active
<b>m Tank</b>	INFO	If active, it shows that the water presence sensor in the tank is  active and water is present at least to the level of the sensor

Press DX1 to go to the next page

### 4 Heaters & Grinder

4 Heaters & Grinder			
Heater1	Heater2	△	St. Out
Grinder	EVdose	▽	^
m Bean	m Dose	Grinder Block	
T1 xx	T2 yy	NoBean	T. 0

SECTOR	TYPE	DESCRIPTION
<b>Heater 1</b>	FUNCTION	If on it activates the coffee boiler for the duration of T.O. (8 seconds). The boiler turns on only if the coffee boiler temperature is lower than 130°C
<b>Heater 2</b>	FUNCTION	If on it activates the water/steam boiler for the duration of T.O. (8 seconds). The boiler turns on only if the water/steam boiler temperature is lower than 130°C
<b>Grinder</b>	FUNCTION	If activated, it starts the coffee grinder. The coffee grinder operates until the same activation key is pressed again, or until the coffee empty signal is triggered, or the doser chamber is filled, that is to say if the "m Dose" microswitch is not pressed. The coffee grinder does not start if the "m Bean" sensor is not active (beans lid closed)
<b>EVdose</b>	FUNCTION	It activates the doser solenoid valve for 0.5 sec. (actual activation occurs only if: - the grounds drawer and the brew unit niche drawer are assembled and the side door is closed)
<b>St.Out</b>	FUNCTION	If selected, it activates the Steam-Out function
<b>m Bean</b>	INFO	If active, it shows the closing of the bean container lid
<b>m Dose</b>	INFO	If active, it shows that the doser microswitch is pressed the doser chamber is full
<b>Grinder Block</b>	INFO	If it activates, it shows the coffee grinder safety block
<b>T1</b>	INFO	Shows the temperature of the coffee boiler in °C
<b>T2</b>	INFO	Shows the temperature of the water/steam boiler in °C
<b>NoBean</b>	INFO	If activated, it shows that the absence of coffee has been detected
<b>T. 0</b>	INFO	Shows the count of 8 seconds for the activation of the boilers

## 5.2. Diagnostic mode

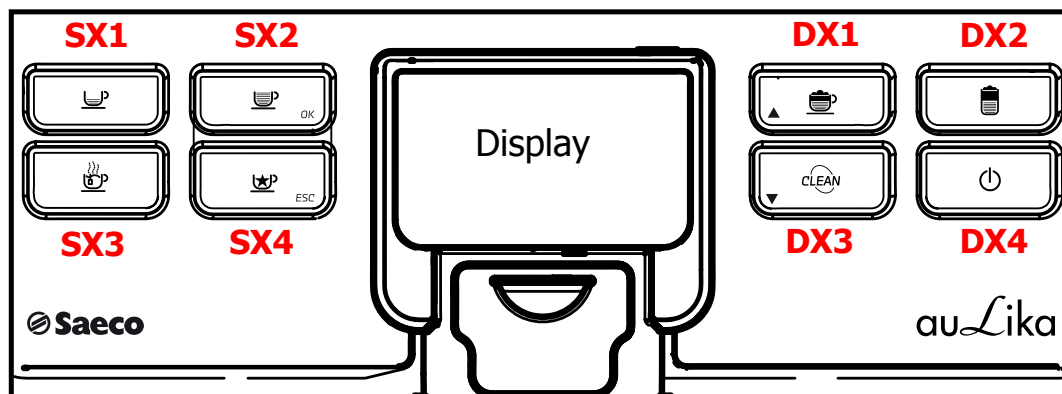

### To access the Diagnostic Mode:

- Turn on the machine
- Press the four function keys in the sequence shown below (**SX1, SX2, SX3, SX4**) before the initialization bar is complete

### Menu description in diagnostic mode

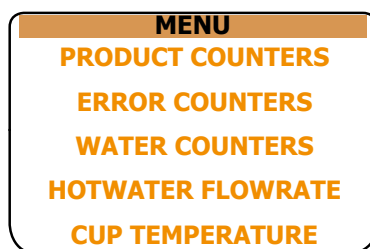

#### 1. Product counters

- Espresso
- Coffee
- Caffè lungo
- American Coffee
- Hot water
- Cappuccino
- Milk coffee
- Hot milk

#### 2. Error counters

##### 2.1. Error log

- Error code
- Error index
- Error text

##### 2.2. Errors reset

#### 3. Water counters

##### 3.1. Descaling cycle

- Since last
- Since second last
- Since third last
- Number of execution

##### 3.2. Brewing unit cleaning

- Number of execution
- Since last

##### 3.3. Since production

##### 3.4. Water filter

- Since last reset
- Number of reset

#### 4. Hotwater flowrate

- 100 ÷ 150

#### 5. Cup temperature

- 75 ÷ 85

Press the **DX1** or **DX3** keys to move the cursor over the desired product and press **SX2** to access the submenu

### 1. PRODUCT COUNTERS

• ESPRESSO (default value 0)	• n° of executions
• COFFEE (valore di default 0)	• n° of executions
• CAFFE LUNGO (valore di default 0)	• n° of executions
• AMERICAN COFFEE (valore di default 0)	
• HOT WATER (default value 0)	• n° of executions
• CAPPUCCINO (default value 0)	• n° of executions
• MILK COFFEE (default value 0)	• n° of executions
• HOT MILK (default value 0)	• n° of executions

### 2. ERROR COUNTERS

• ERRORS LOG • (default value 0)	• ERROR CODE • (default value 0)	ERROR CODE - represents the code for the type of error that has occurred (see Tab. 5.3 Error messages)
	• ERROR INDEX • (default value 0)	NUMERICAL POSITION - represents the numerical position of the error in the internal list, for a max. n° of 20
	• ERROR TEXT • (default value 0)	ERROR DESCRIPTION - represents the text description of the type of error that has occurred

• ERRORS RESET	All errors are reset
----------------	----------------------

### 3. WATER COUNTERS

• DESCALING CYCLES	• SINCE LAST • (default value 0)	This represents water consumption after the last descaling cycle.
	• SINCE SECOND LAST • (default value 0)	As above, only after the second last descaling cycle
	• SINCE THIRD LAST • (default value 0)	As above, only after the third last descaling cycle
	• NUMBER OF EXECUTION (default value 0)	Total n° of descaling cycles performed

• BREWING UNIT CLEANING	• NUMBER OF EXECUTION • (default value 0)	This represents water consumption after the last brewing unit cleaning cycle. When performed, it is reset to 0
	• SINCE LAST • (default value 0)	This represents the number of brewing unit cleaning cycles performed on the C.A.

• WATER FILTER	• SINCE LAST RESET • (default value 0)	This represents water consumption after the last filter activation cycle. When performed, it is reset to 0
	• NUMBER OF RESET • (default value 0)	Total n° of filter activation cycles performed

• WATER SINCE PRODUCT	Total water consumption in litres (default value 0)
-----------------------	---

### 6. HOTWATER FLOWRATE

100 ÷ 150 (default value 120)

### 7. CUP TEMPERATURE

75 ÷ 85 (default value 78)

### 5.3. Error messages

code	brief description	description
01	coffee grinder blocked	the coffee grinder is blocked (the burrs are stuck or the sensor does not read accurately)
03	brewing unit blocked in "work" mode	the descent time out has been exceeded
04	brewing unit blocked in "home" mode	the ascent time out has been exceeded
05	water circuit interrupted	no water flows into the turbine
06	emulsifier unit solenoid valve	short circuit of a solenoid valve in the emulsifier unit
07	doser microswitch blocked	short circuit of the doser microswitch
10	coffee boiler short-circuited	short-circuit in the temperature sensor of the coffee boiler
11	coffee boiler open circuit	open circuit in the temperature sensor of the coffee boiler
12	steam boiler short-circuited	short-circuit in the temperature sensor of the steam boiler
13	steam boiler open circuit	open circuit in the temperature sensor of the steam boiler
14	various temperature errors (of the coffee boiler)	coffee boiler temperature out of control
15	various temperature errors (of the steam boiler)	steam boiler temperature out of control
16	brewing unit short-circuited	short circuit of the brewing unit microswitch
17	not used	
18	not used	
19	zero crossing fault	no zero crossing on the card, the cause might derive from the power card
20	not used	



# CHAPTER 6

# STANDARD CHECKS

### 6.1. Repairs schedule

	<b>Activity</b>
<b>1</b>	Visual exam (transportation damage)
<b>2</b>	Machine data check (tag)
<b>3</b>	Functional check / problem analysis
<b>4</b>	Opening of the machine
<b>5</b>	Visual check
<b>6</b>	Functional tests
<b>7</b>	Elimination of defect, if any
<b>8</b>	Check for modifications (see Symptom Cure, new software, etc.)
<b>9</b>	Service activities according to the operating program
<b>10</b>	Internal cleaning
<b>11</b>	Functional test with the machine open
<b>12</b>	Assembly
<b>13</b>	Final check test
<b>14</b>	Circuit emptying (in winter)
<b>15</b>	External cleaning
<b>16</b>	Lubrication of the brewing unit with the appropriate grease
<b>17</b>	HG 701 (dielectric) insulation test
<b>18</b>	Documentation

### 6.2. Service schedule

**S** Replacement

**ES** Visual check

**D** Descaling

**CF** Functional Check

**P** Cleaning

**TR** Noise test

**R** Calibration

<b>Component</b>	<b>Activity</b>	<b>Support/tool</b>
Water filter	<b>P/S/CF</b>	
Lip gasket of the water tank	<b>S/CF</b>	
O-Ring of the boiler pin	<b>S/CF</b>	
Brewing unit	<b>ES/P/CF</b>	Degreaser / Grease
Pipes, joints and Oetiker clamps	<b>ES/CF</b>	
Coffee circuit pump	<b>ES/TR/CF</b>	
Hot water/steam circuit pump	<b>ES/TR/CF</b>	
Gearbox	<b>ES/TR/CF</b>	
Coffee grinder	<b>P/R/CF</b>	Vacuum cleaner / brush
Hydraulic Circuit	<b>D/CF</b>	Saeco Descaler
Emulsion valve unit	<b>ES/S/CF</b>	
Multiple-way valve (solenoid valve)	<b>ES/S/CF</b>	

**6.3. Final check**

<b>Test</b>	<b>Procedure</b>	<b>Support / tool</b>	<b>Standard</b>	<b>Tolerance</b>
Espresso	2-3 espressos for calibration	Measuring cup	Same quantity	15%
Coffee	2-3 coffees for calibration	Measuring cup	Same quantity	15%
Noise			Standard	
Cream quantity	Blow in the cup until the cream separates		The cream must merge back again	
Cream colour			Nocciola	
Temperature	Measuring during execution	Thermometer	75 °C	± 5 °C
Grinding	Check the granulometry of the ground coffee			
Hot water	Deliver water			
Steam	Deliver steam			
Grounds drawer absence warning	Remove the grounds drawer		Grounds drawer absence warning	
Coffee beans absent warning	Brew one coffee with the beans container empty		Coffee beans absent warning	



# CHAPTER 7

# DISASSEMBLY

### 7.1. Aesthetics



Remove the lid and the water tank, the beans container lid, the grounds drawer, the drip tray, the brewing unit, the brewing unit support plate and the coffee dispenser.



Loosen the screws shown in the picture and remove the coffee container



Loosen the screws shown in the picture

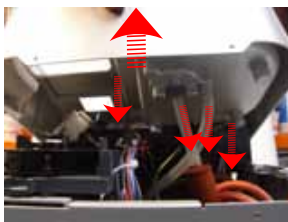

Lift the upper cover and slide out the power and hydraulic connections that prevent it from being removed completely.



Slide out the pin shown in the picture and remove the door.

### 7.2. Coffee grinder

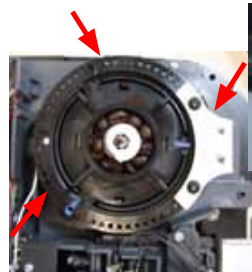

Anti vibration mount

Slide out the cover shown in the picture from the calibration lever and slide out the coffee grinder after detaching it from the anti vibration mounts shown in the picture and from the power connections.

Exploded diagram of the coffee grinder

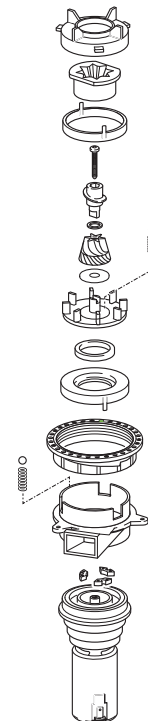

### 7.3. Burrs

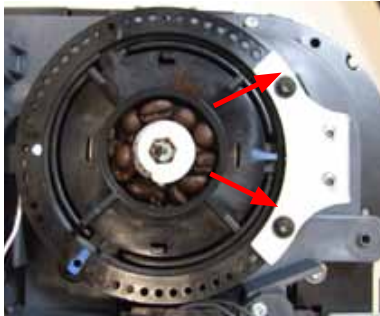

Loosen the screws shown in the picture and remove the calibration lever.

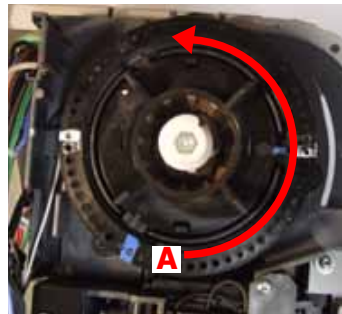

To remove the upper support of the burr, rotate the metal ring (A) counter-clockwise until it uncouples.

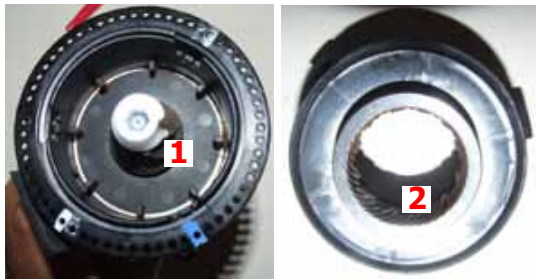
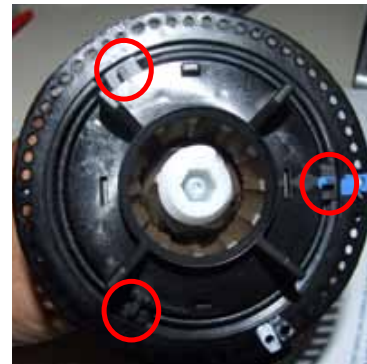

Lower burr (1) and upper burr (2)

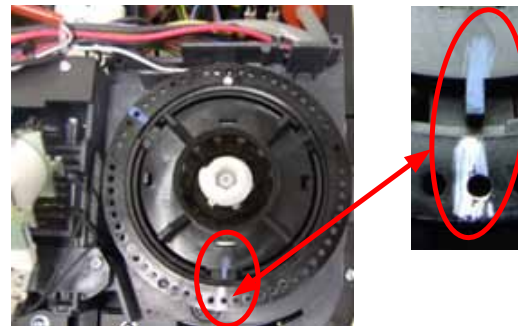

In replacing the burrs, take care that the two references shown in the picture are aligned



Loosen the screw shown in the picture and remove the lower burr. In the assembly, pay attention to replace the three springs and the three spheres correctly.



Removed the cover of the upper burr by pressing on the blades shown in the picture (A) and remove the burr uncoupling it from the stops shown in the picture.

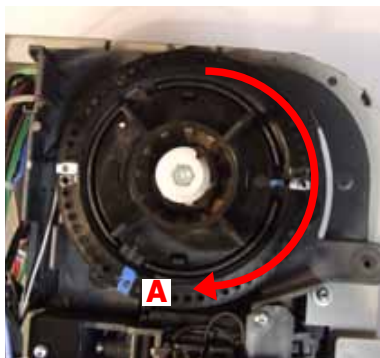

**To adjust the distance between the burrs**  
 - reconnect the coffee grinder and turn it on  
 - rotate the metal ring (A) clockwise carefully, until the two burrs brush against each other  
 - rotate the metal ring (A) back counter-clockwise by one notch

#### 7.4. Coffee grinder motor



Remove the spheres shown in the picture and the springs underneath and lift the burr support

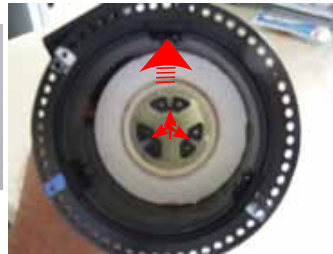

Remove the three burr dampers and the felt ring



Unlock the motor support by lifting the stops shown in the picture and replace the motor.

#### 7.5. Coil, microswitch and doser door

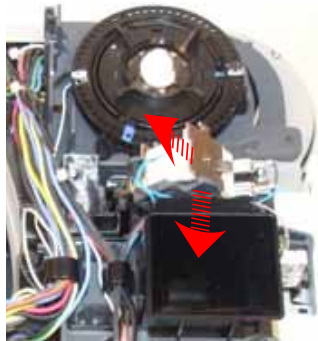

Loosen the stop shown in the picture and lift the coil

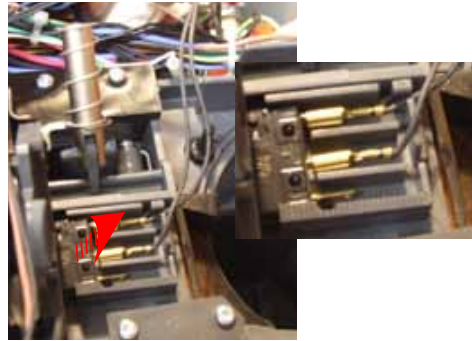

Remove the power connections and slide out the microswitch

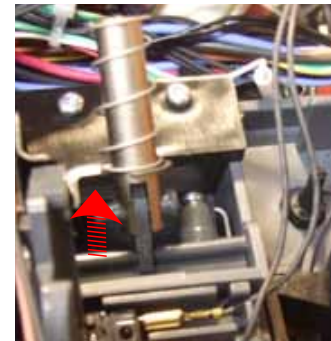

Lift the pin of the doser door with a lever and slide it out

#### 7.6. Doser hopper

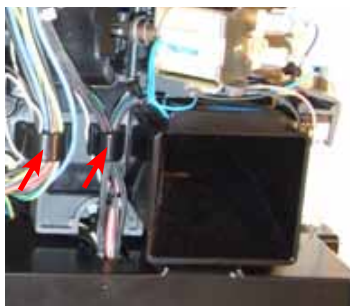

Remove the cables from the cable ties shown in the picture

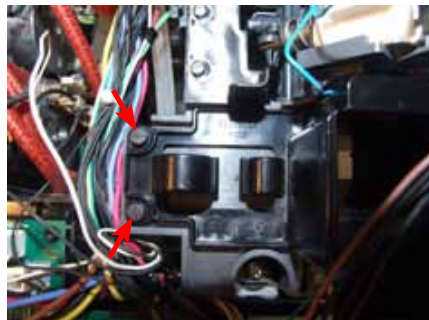

Lift the hopper and separate it from the rubber fastenings shown in the picture

### 7.7. Coffee boiler and steam boiler

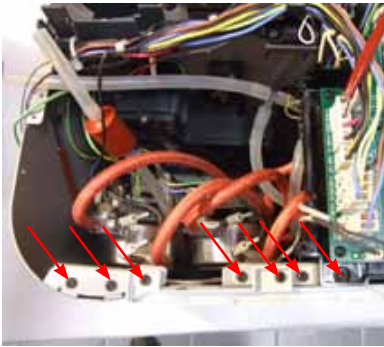

Loosen the screws shown in the picture and remove the boiler support

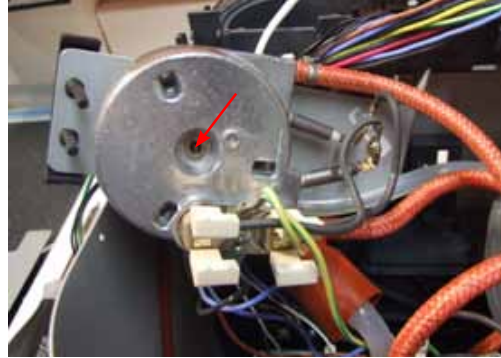

Loosen the screw shown in the picture, remove the boiler support and slide the power and hydraulic connections out

### 7.8. Boiler pin



Loosen the screws shown in the picture and remove the cover of the boiler pin

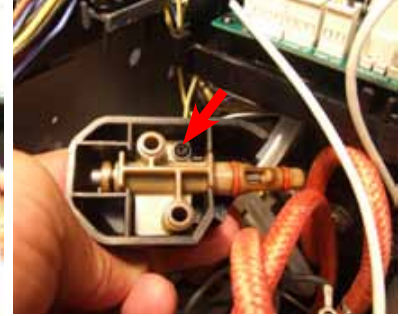
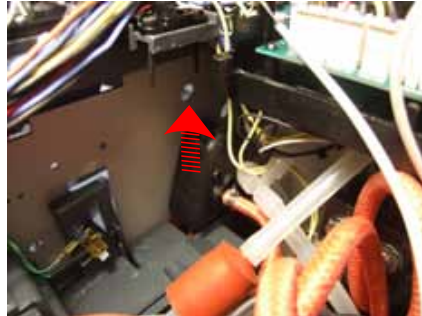

Slide the pin support out and loosen the screw shown in the picture

### 7.9. Coffee pump and steam pump



Remove the boiler support, slide the pump out of its stays and disconnect the power and hydraulic connections.



Remove the boiler support, slide the pump out of its stays and disconnect the power and hydraulic connections.

### 7.10. Turbine

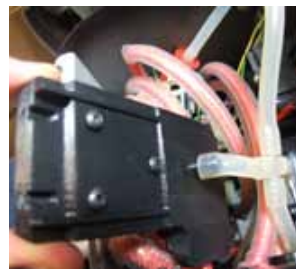

to replace the turbine, loosen the screws inside the brewing unit niche shown in the picture

to replace the turbine, loosen the screws inside the brewing unit niche shown in the picture

### 7.11. Gearbox

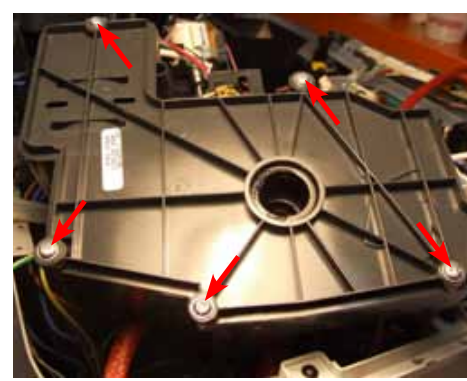
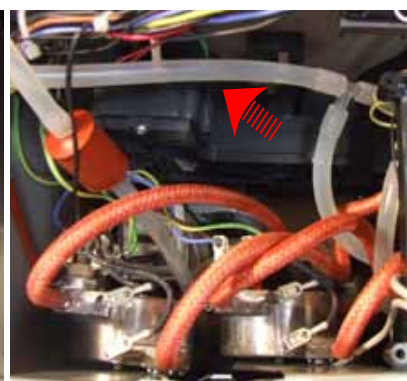
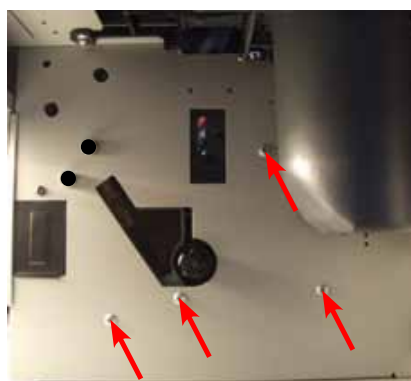

Loosen the screws shown in the picture and remove the gearbox assembly

Loosen the screws shown in the picture and remove the gearbox lid

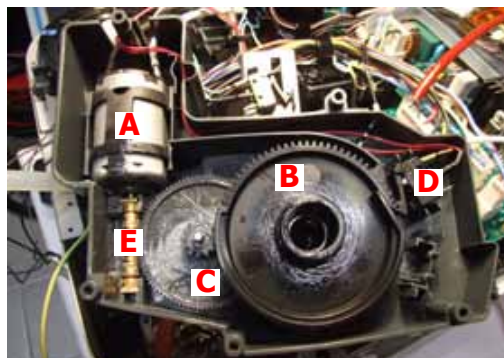

- Inside the compartment protected by the casing there are:
- the electric motor (A) with the gears (B) and (C) that operate the gearbox and the timing of the brewing unit.
- The Microswitch (D) intercepting both the idle phase and the execution phase of the brewing unit.
- Slide out the big gear (B)
- Slide out the gear (C) that meshes with the drive shaft of the motor
- Remove the motor (A) together with its drive shaft (E)

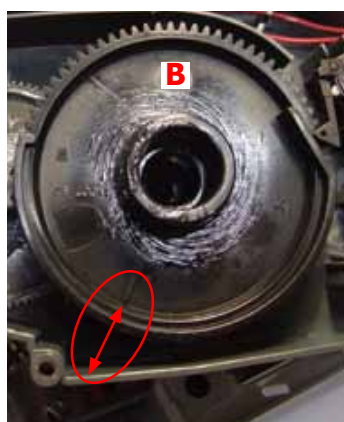

**When reassembling the gear (B), pay attention that the arrow sign is in the same position as shown in the picture**



When reassembling the motor and drive shaft, pay attention that the tracks (L) are slid back in their proper seats. Grease the drive shaft abundantly and uniformly.

### 7.12. Discharge valve

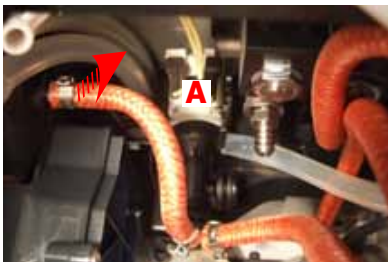

To remove the discharge valve (A), loosen the screws that fasten the cover of the boiler pin and remove the valve.



Loosen the screws shown in the picture to remove the base and access the screw located under the chassis of the machine

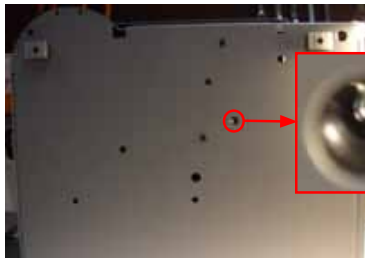

Loosen the screw located under the machine and shown in the picture



Disconnect the power and hydraulic connections

### 7.13. Solenoid valves assembly



Remove the front cover of the chassis as follows:

- loosen the screw shown in the picture (A)
- Move the cover towards the left to unlock the stops (B)
- lift the bottom part of the cover to remove the stop (C)
- pull outwards

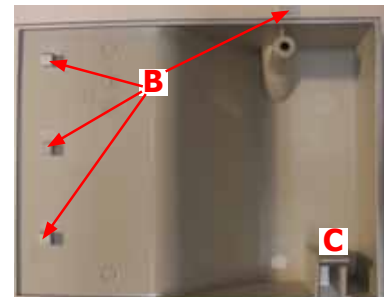

Loosen the screws shown in the picture and remove the card support for easier access to the solenoid valves assembly



Loosen the screws under the front cover of the chassis as shown in the picture



Slide out the power and hydraulic connections



Loosen the screws

**7.14. Steam tube assembly**



Loosen the screws shown in the picture and remove the card support for easier access to the steam tube assembly



Loosen the screws shown in the picture and remove the yoke spring

**7.15. Dispenser assembly**



Loosen the screws shown in the picture and remove the card support for easier access to the dispenser



Loosen the screws shown in the picture, remove the display assembly and the dispenser assembly

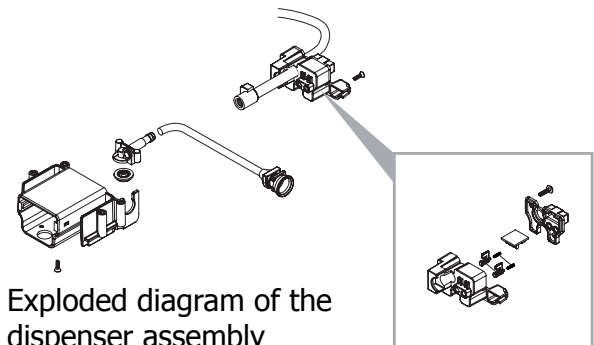

Exploded diagram of the dispenser assembly

**7.16. Power Card**

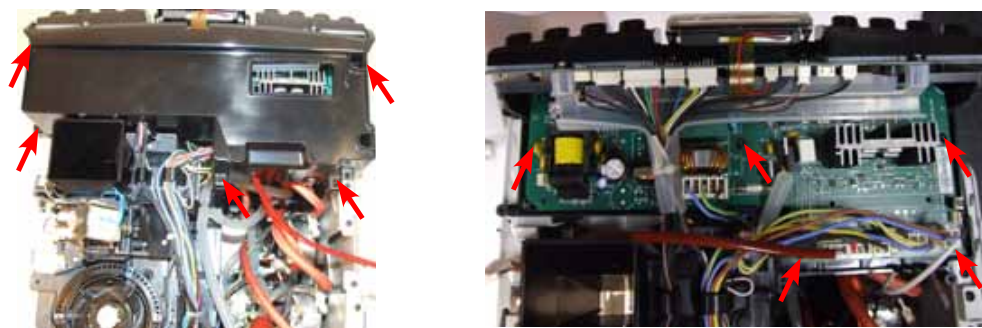

Loosen the screws shown in the picture and remove the cards cover

Loosen the screw shown in the picture, remove the card cover and disconnect the power connections

### 7.17. Display, keypads and CPU Board



Loosen the screws shown in the picture, disconnect the power connections and remove the display assembly

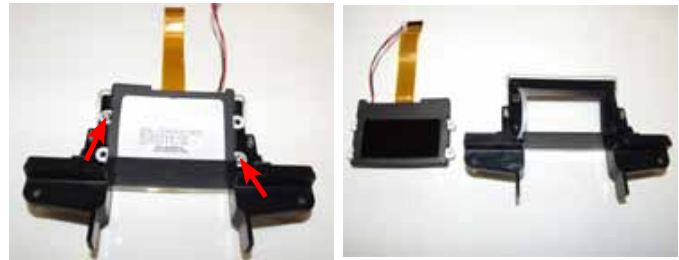

Loosen the screws shown in the picture from the back of the display assembly



Loosen the screws shown in the picture and remove the keypads



Loosen the screws shown in the picture and disconnect the power connections

### 7.18. Assembly and disassembly of Oetiker clamps

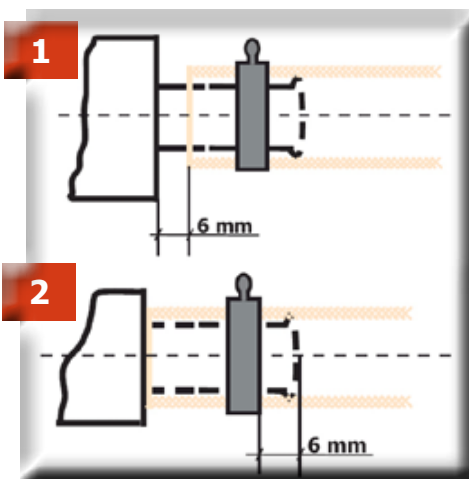

1) Boiler connection

2) Other connections



To remove the clamp use appropriate pliers, as shown in the picture



Fasten the clamp as shown

**7.19. Connection to the water supply system**



Loosen the screws shown in the picture and remove the back panel



Loosen the screw shown in the picture and remove the back panel



Disconnect the power and hydraulic connections shown in the picture and connect them to the kit (see picture below)

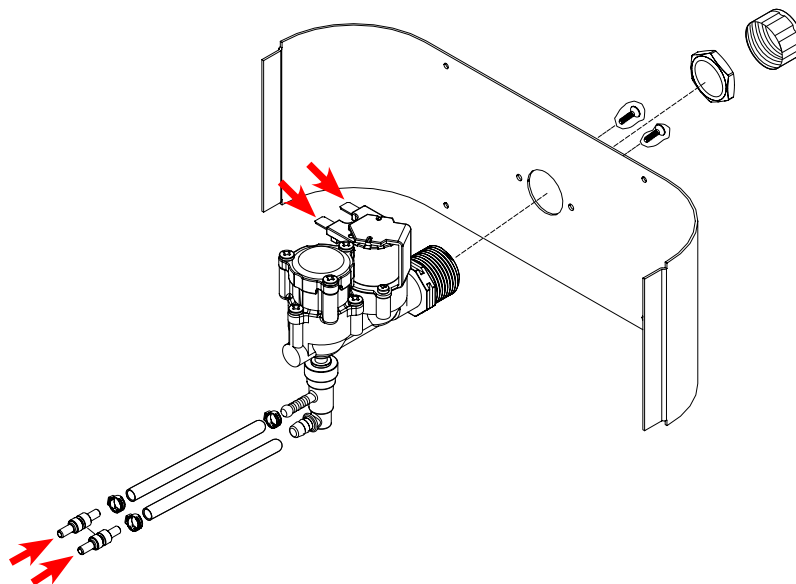



# CHAPTER 8

# NOTES





# CHAPTER 9

# HYDRAULIC DIAGRAM





# CHAPTER 10

# ELECTRIC DIAGRAM

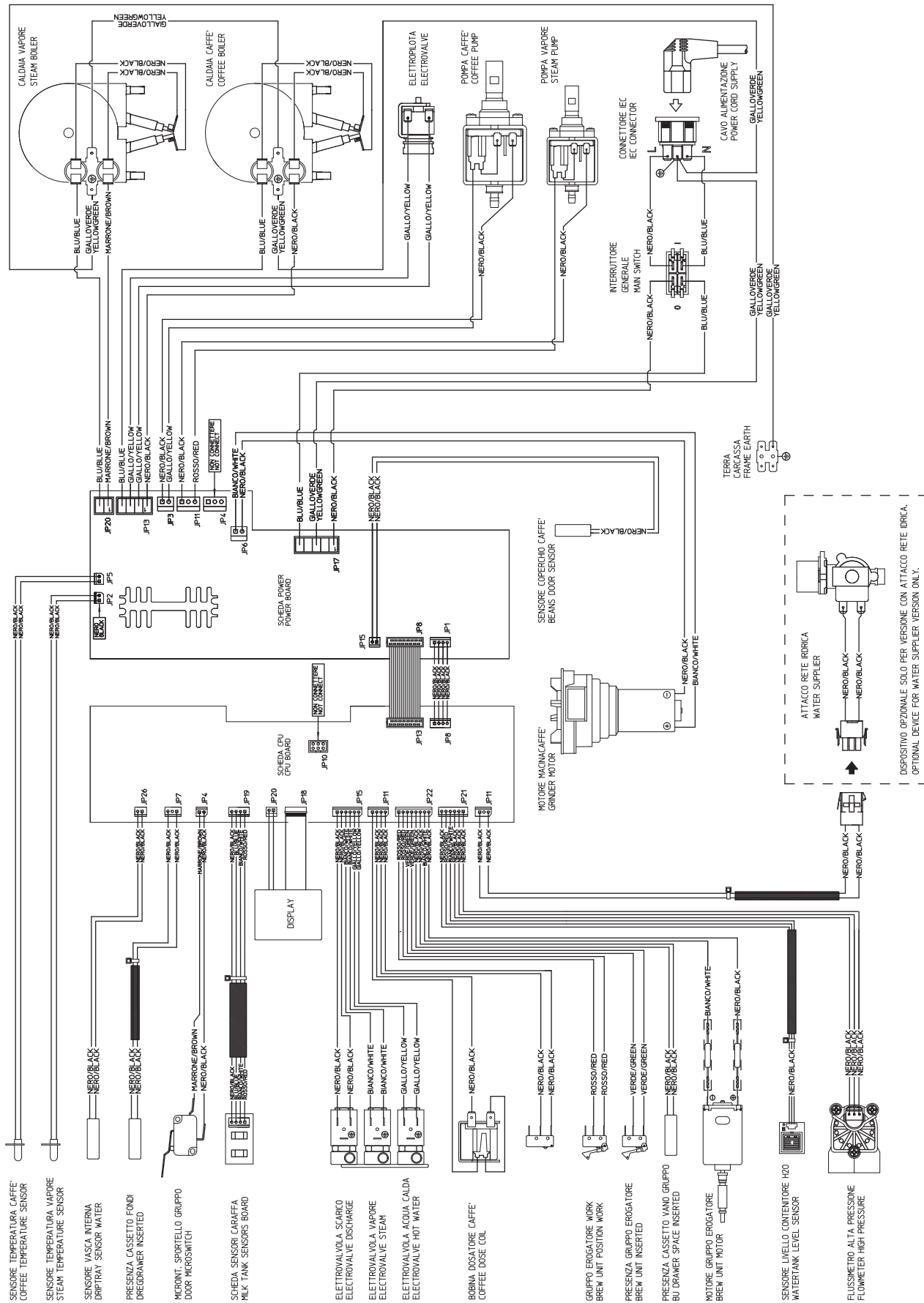

- SENSORE TEMPERATURA CAFFÈ / COFFEE TEMPERATURE SENSOR
- SENSORE TEMPERATURA VAPORE / STEAM TEMPERATURE SENSOR
- SENSORE VASCA INTERNA DRIPTRAY / SENSOR WATER
- PRESENZA CASSETTO FONDI DREGRAWER INSERTED
- MICROINT. SPORTELLINO GRUPPO DOOR MICROSWITCH
- SCHEDA SENSORI CARAFFA MILK TANK SENSORS BOARD
- ELETTROVALVOLA SCARICO / ELECTROVALVE DISCHARGE
- ELETTROVALVOLA VAPORE / ELECTROVALVE STEAM
- ELETTROVALVOLA ACQUA CALDA / ELECTROVALVE HOT WATER
- BOBINA DOSATORE CAFFÈ / COFFEE DOSE COIL
- GRUPPO ERGATORE WORK BREW UNIT POSITION WORK
- PRESENZA GRUPPO ERGATORE BREW UNIT INSERTED
- PRESENZA CASSETTO VANO GRUPPO BU DRAMER SPALLE INSERTED
- MOTORE GRUPPO ERGATORE BREW UNIT MOTOR
- SENSORE LIVELLO CONTENITORE H2O / WATERTANK LEVEL SENSOR
- FLUSSIMETRO ALTA PRESSIONE / FLOWMETER HIGH PRESSURE