

SHARP SERVICE INFORMATION

Issued: August 2011

LED LCD COLOUR TELEVISION

MHP, CONNECTED TV / DVB-T / DVB-C (HDTV) / DVB-S/S2, PAL_{B/G, I} / SECAM_{B/G, D/K, L/L'} / NTSC SYSTEM COLOUR TELEVISION



MODELS

LC-60LE635E/RU

LC-60LE638E

In the interests of user safety (required by safety regulations in some countries) the set should be restored to its original condition and only parts identical to those specified should be used.

CONTENTS

ELECTRICAL SPECIFICATIONS	2
IMPORTANT SERVICE SAFETY PRECAUTIONS.....	4
OPERATION MANUAL	7
DIMENSIONS	13
REMOVING OF MAJOR PARTS	14
SERVICE ADJUSTMENTS	16
SOFTWARE UPDATING	37
TROUBLESHOOTING TABLE	38
MAJOR ICs INFORMATION	59
CHASSIS LAYOUT	60
WIRING DIAGRAMS	65
BLOCK DIAGRAMS	67
SCHEMATIC DIAGRAMS	68
PRINTED WIRING BOARDS	99
REPLACEMENT PARTS LIST	108
CABINET AND MECHANICAL PARTS	121
ACCESSORIES AND PACKING OF THE SET	123

ELECTRICAL SPECIFICATIONS

Specifications

Item		LCD COLOUR TV (60"/152 cm), LC-60LE635E LC-60LE635RU	
LCD panel		152 cm (60") X-Gen panel	
Resolution		1,920 x 1,080 x 3 dots	
Video colour system		PAL/SECAM/NTSC 3.58/NTSC 4.43/PAL 60	
TV function	TV-standard	Analogue	CCIR (B/G, I, D/K, L/L')
		Digital (635 series)	DVB-T (2K/8K OFDM), DVB-C, DVB-S/S2
	Receiving channel	Digital (636 series)	DVB-T (2K/8K OFDM), DVB-T2 (1K/2K/4K/8K/16K/32K OFDM), DVB-C
		VHF/UHF	IR A ch–E69 ch (Digital), E2–E69 ch, F2–F10 ch, I21–I69 ch, IR A–IR J ch
		CATV	Hyper-band, S1–S41 ch
TV-tuning system	Satellite (635 series only)	950–2150 MHz*1	
	Auto Preset 999 ch (non-Nordic [DTV]), Auto Preset 9999 ch (Nordic [DTV]), Auto Preset 99 ch (ATV), Auto Label, Auto Sort, Auto Preset 9999 ch (SAT [635 series only])		
Stereo/Bilingual		A2/NICAM	
Audio amplifier		10 W x 2	
Speaker		(150 mm x 32 mm) x 2	
Terminals	Antenna	VHF/UHF	75 Ω Din type (analogue & digital)
		Satellite (635 series only)	75 Ω F type (DVB-S/S2)
	RS-232C	D-sub 9 pin male connector	
	EXT 1	SCART (AV input, Y/C input, RGB input, TV output)	
	EXT 2	RCA pin (AV input/AUDIO L/R)	
	EXT 3	Component (AV input/Audio L/R)	
	PC	mini D-sub 15 pin	
	HDMI 1 (EXT 4)	HDMI (ARC)	
	HDMI 2 (EXT 5)	HDMI	
	HDMI 3 (EXT 6)	HDMI	
HDMI 4 (EXT 7)	HDMI		
USB 1	USB		
USB 2 (HDD)	USB		
USB 3 (WIRELESS LAN)	USB		
ETHERNET (10/100)	Network connector		
HDMI 2/PC AUDIO (L/R)	Ø 3.5 mm jack*2		
DIGITAL AUDIO OUTPUT	Optical S/PDIF digital audio output		
C. I. (Common Interface)	EN50221, R206001, CI Plus specification		
OUTPUT/Headphones	RCA pin (AUDIO L/R)/Ø 3.5 mm jack (audio output)		
SD CARD (VIDEO STORE)	SD card		
OSD language		Czech, Danish, Dutch, English, Estonian, Finnish, French, German, Greek, Hungarian, Italian, Latvian, Lithuanian, Norwegian, Polish, Portuguese, Russian, Slovak, Slovene, Spanish, Swedish, Turkish, Ukrainian, Romanian	
Power requirement		AC 220–240 V, 50 Hz	
Power consumption (method IEC62087)		168 W 0.1 W standby*3	
Weight		XX.X kg (without stand) XX.X kg (with stand)	
Operating temperature		0 °C to + 40 °C	

*1 The satellite channel's frequency may vary according to satellites and antennas.

*2 The HDMI 2 and PC terminals can both use the same audio input terminal.

*3 Standby power consumption applies when the TV is set to not receive EPG data.

• As a part of our policy of continuous improvement, SHARP reserves the right to make design and specification changes for product improvement without prior notice. The performance specification figures indicated are nominal values of production units. There may be some deviations from these values in individual units.

Item		LCD COLOUR TV (60"/152 cm), LC-60LE638E	
LCD panel		152 cm (60") X-Gen panel	
Resolution		1,920 x 1,080 x 3 dots	
Video colour system		PAL/SECAM/NTSC 3.58/NTSC 4.43/PAL 60	
TV function	TV-standard	Analogue	CCIR (B/G, I, D/K, L/L')
		Digital	DVB-T (2K/8K OFDM), DVB-C, DVB-S/S2
	Receiving channel	VHF/UHF	IR A ch–E69 ch (Digital), E2–E69 ch, F2–F10 ch, I21–I69 ch, IR A–IR J ch
		CATV	Hyper-band, S1–S41 ch
		Satellite	950–2150 MHz*1
TV-tuning system		Auto Preset 999 ch (non-Nordic [DTV]), Auto Preset 9999 ch (Nordic [DTV]), Auto Preset 99 ch (ATV), Auto Label, Auto Sort, Auto Preset 9999 ch (SAT)	
Stereo/Bilingual		A2/NICAM	
Audio amplifier		10 W x 2	
Speaker		(150 mm x 32 mm) x 2	
Terminals	Antenna	VHF/UHF	75 Ω Din type (analogue & digital)
		Satellite	75 Ω F type (DVB-S/S2)
	RS-232C	D-sub 9 pin male connector	
	EXT 1	SCART (AV input, Y/C input, RGB input, TV output)	
	EXT 2	RCA pin (AV input/AUDIO L/R)	
	EXT 3	Component (AV input/Audio L/R)	
	PC	mini D-sub 15 pin	
	HDMI 1 (EXT 4)	HDMI (ARC)	
	HDMI 2 (EXT 5)	HDMI	
	HDMI 3 (EXT 6)	HDMI	
HDMI 4 (EXT 7)	HDMI		
USB 1	USB		
USB 2 (HDD)	USB		
USB 3 (WIRELESS LAN)	USB		
ETHERNET (10/100)	Network connector		
HDMI 2/PC AUDIO (L/R)	Ø 3.5 mm jack*2		
DIGITAL AUDIO OUTPUT	Optical S/PDIF digital audio output		
C. I. (Common Interface)	EN50221, R206001, CI Plus specification		
OUTPUT/Headphones	RCA pin (AUDIO L/R)/Ø 3.5 mm jack (audio output)		
SD CARD (VIDEO STORE)	SD card		
OSD language		Czech, Danish, Dutch, English, Estonian, Finnish, French, German, Greek, Hungarian, Italian, Latvian, Lithuanian, Norwegian, Polish, Portuguese, Russian, Slovak, Slovene, Spanish, Swedish, Turkish, Ukrainian, Romanian	
Power requirement		AC 220–240 V, 50 Hz	
Power consumption (method IEC62087)		168 W 0.1 W standby*3	
Weight		XX.X kg (without stand) XX.X kg (with stand)	
Operating temperature		0 °C to + 40 °C	

*1 The satellite channel's frequency may vary according to satellites and antennas.

*2 The HDMI 2 and PC terminals can both use the same audio input terminal.

*3 Standby power consumption applies when the TV is set to not receive EPG data.

• As a part of our policy of continuous improvement, SHARP reserves the right to make design and specification changes for product improvement without prior notice. The performance specification figures indicated are nominal values of production units. There may be some deviations from these values in individual units.

Cautions regarding use in high and low temperature environments

- When the unit is used in a low temperature space (e.g. room, office), the picture may leave trails or appear slightly delayed. This is not a malfunction, and the unit will recover when the temperature returns to normal.
- Do not leave the unit in a hot or cold location. Also, do not leave the unit in a location exposed to direct sunlight or near a heater, as this may cause the cabinet to deform and the LCD panel to malfunction. Storage temperature: –20°C to +60°C.

- As a part of our policy of continuous improvement, SHARP reserves the right to make design and specification changes for product improvement without prior notice. The performance specification figures indicated are nominal values of production units. There may be some deviations from these values in individual units.

ELECTRICAL SPECIFICATIONS (continued)

Specifications (Wireless LAN USB adapter)

Product name		Dual Band 802.11n USB2.0 adapter	
Standard		IEEE 802.11a/b/g/n	
Host interface		USB2.0	
Frequency band		2412–2484 MHz 5150–5850 MHz	
Security		Static WEP (64/128 bit, key index 1 only) WPA-PSK (TKIP) WPA2-PSK (AES)	
Modulation		DBPSK@1 Mbps DQPSK@2 Mbps CCK@5.5/11 Mbps BPSK@6/9 Mbps QPSK@12/18 Mbps 16-QAM@24 Mbps 64-QAM@48/54 Mbps and above, Rx up to 300 Mbps	
Transmit power and sensitivity	Tx output power: (Typical)	2.4 GHz	11b 17 +/- 1.5 dBm 11g 14 +/- 1.5 dBm 11n 13 +/- 1.5 dBm
		5 GHz (5150–5250 MHz, 5250–5350 MHz)	11a 14 +/- 1.5 dBm 11n 13 +/- 1.5 dBm
		5 GHz (5470–5725 MHz, 5725–5850 MHz)	11a 13 +/- 1.5 dBm 11n 13 +/- 1.5 dBm
	Rx sensitivity: (Typical)	–84 dBm@11 Mbps –72 dBm@54 Mbps –64 dBm@64-QAM, 20 MHz channel spacing –61 dBm@64-QAM, 40 MHz channel spacing	
Current Consumption (5V DC)		Tx: 2.2 W (Typical) Rx: 1.4 W (Typical)	
Weight		13 g	
Dimensions		20.0 (W) × 73.3 (D) × 8.0 (H) mm	
Operating temperature		0 °C to + 40 °C	

IMPORTANT SERVICE SAFETY PRECAUTION

Service work should be performed only by qualified service technicians who are thoroughly familiar with all safety checks and the servicing guidelines which follow:

WARNING

1. For continued safety, no modification of any circuit should be attempted.
2. Disconnect AC power before servicing.

CAUTION: FOR CONTINUED PROTECTION AGAINST A RISK OF FIRE REPLACE ONLY WITH SAME TYPE F7001 T5AH / 250V.

BEFORE RETURNING THE RECEIVER (Fire & Shock Hazard)

Before returning the receiver to the user, perform the following safety checks:

1. Inspect all lead dress to make certain that leads are not pinched, and check that hardware is not lodged between the chassis and other metal parts in the receiver.
2. Inspect all protective devices such as non-metallic control knobs, insulation materials, cabinet backs, adjustment and compartment covers or shields, isolation resistor-capacitor networks, mechanical insulators, etc.
3. To be sure that no shock hazard exists, check for leakage current in the following manner.

- Plug the AC cord directly into a 220~240 volt AC outlet. (Do not use an isolation transformer for this test).
- Using two clip leads, connect a 1.5k ohm, 10 watt resistor paralleled by a 0.15 μ F capacitor in series with all exposed metal cabinet parts and a known earth ground, such as electrical conduit or electrical ground connected to an earth ground.
 - A true RMS reading multimeter should be used for this test, especially where the equipment uses a switch mode power supply which may result in very non-sinusoidal leakage current.
 - Connect the resistor connection to all exposed metal parts having a return to the chassis (antenna, metal cabinet, screw heads, knobs and control shafts, escutcheon, etc.) and measure the AC voltage drop across the resistor.

All checks must be repeated with the AC cord plug connection reversed. (If necessary, a nonpolarized adaptor plug must be used only for the purpose of completing these checks.)

Any reading of 1.05V peak (this corresponds to 0.7 mA. peak AC.) or more is excessive and indicates a potential shock hazard which must be corrected before returning the monitor to the owner.

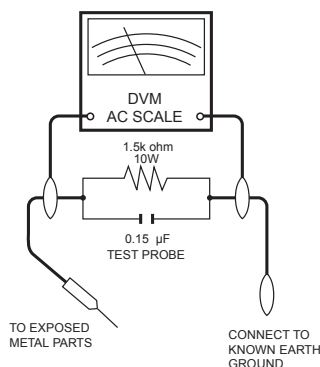

SAFETY NOTICE

Many electrical and mechanical parts in LCD television have special safety-related characteristics. These characteristics are often not evident from visual inspection, nor can protection afforded by them be necessarily increased by using replacement components rated for higher voltage, wattage, etc. Replacement parts which have these special safety characteristics are identified in this manual; electrical components having such features are identified by “ \triangle ”.

For continued protection, replacement parts must be identical to those used in the original circuit. The use of a substitute replacement parts which do not have the same safety characteristics as the factory recommended replacement parts shown in this service manual, may create shock, fire or other hazards.

PRECAUTIONS FOR USING LEAD-FREE SOLDER

1 Employing lead-free solder

“ALL PWB” of this model employs lead-free solder. The LF symbol indicates lead-free solder, and is attached on the PWBs and service manuals. The alphabetical character following LF shows the type of lead-free solder.

Example:

LFa
Sn-Ag-Cu Indicates lead-free solder of tin, silver and copper.

LFn
Sn-Ag-Ni Indicates lead-free solder of tin, silver and nickel.

2 Using lead-free wire solder

When fixing the PWB soldered with the lead-free solder, apply lead-free wire solder. Repairing with conventional lead wire solder may cause damage or accident due to cracks.

As the melting point of lead-free solder (Sn-Ag-Cu) is higher than the lead wire solder by 40°C, we recommend you to use a dedicated soldering bit, if you are not familiar with how to obtain lead-free wire solder or soldering bit, contact our service station or service branch in your area.

3 Soldering

As the melting point of lead-free solder (Sn-Ag-Cu) is about 220°C which is higher than the conventional lead solder by 40°C, and as it has poor solder wettability, you may be apt to keep the soldering bit in contact with the PWB for extended period of time. However, Since the land may be peeled off or the maximum heat-resistance temperature of parts may be exceeded, remove the bit from the PWB as soon as you confirm the steady soldering condition.

Lead-free solder contains more tin, and the end of the soldering bit may be easily corroded. Make sure to turn on and off the power of the bit as required.

If a different type of solder stays on the tip of the soldering bit, it is alloyed with lead-free solder. Clean the bit after every use of it.

When the tip of the soldering bit is blackened during use, file it with steel wool or fine sandpaper.

Be careful when replacing parts with polarity indication on the PWB silk.

Lead-free wire solder for servicing.

Part No.	★	Description	Code
ZHNDai123250E	J	φ0.3mm 250g(1roll)	BL
ZHNDai126500E	J	φ0.6mm 500g(1roll)	BK
ZHNDai12801KE	J	φ1.0mm 1kg(1roll)	BM

END OF LIFE DISPOSAL



Attention: Your product is marked with this symbol. It means that used electrical and electronic products should not be mixed with general household waste. There is a separate collection system for these products.

A. Information on Disposal for Users (private households)

1. In the European Union

Attention: If you want to dispose of this equipment, please do not use the ordinary dust bin!

Used electrical and electronic equipment must be treated separately and in accordance with legislation that requires proper treatment, recovery and recycling of used electrical and electronic equipment.

Following the implementation by member states, private households within the EU states may return their used electrical and electronic equipment to designated collection facilities free of charge*. In some countries* your local retailer may also take back your old product free of charge if you purchase a similar new one.

*) Please contact your local authority for further details.

If your used electrical or electronic equipment has batteries or accumulators, please dispose of these separately beforehand according to local requirements.

By disposing of this product correctly you will help ensure that the waste undergoes the necessary treatment, recovery and recycling and thus prevent potential negative effects on the environment and human health which could otherwise arise due to inappropriate waste handling.

2. In other Countries outside the EU

If you wish to discard this product, please contact your local authorities and ask for the correct method of disposal.

For Switzerland: Used electrical or electronic equipment can be returned free of charge to the dealer, even if you don't purchase a new product. Further collection facilities are listed on the homepage of www.swico.ch or www.sens.ch.

B. Information on Disposal for Business Users

1. In the European Union

If the product is used for business purposes and you want to discard it:

Please contact your SHARP dealer who will inform you about the take-back of the product. You might be charged for the costs arising from take-back and recycling. Small products (and small amounts) might be taken back by your local collection facilities.

For Spain: Please contact the established collection system or your local authority for take-back of your used products.

2. In other Countries outside the EU

If you wish to discard of this product, please contact your local authorities and ask for the correct method of disposal.



Pb

The battery supplied with this product contains traces of Lead.

For EU: The crossed-out wheeled bin implies that used batteries should not be put to the general household waste! There is a separate collection system for used batteries, to allow proper treatment and recycling in accordance with legislation. Please contact your local authority for details on the collection and recycling schemes.

For Switzerland: The used battery is to be returned to the selling point.

For other non-EU countries: Please contact your local authority for correct method of disposal of the used battery.

OPERATION MANUAL

Part names and functions

Remote control unit

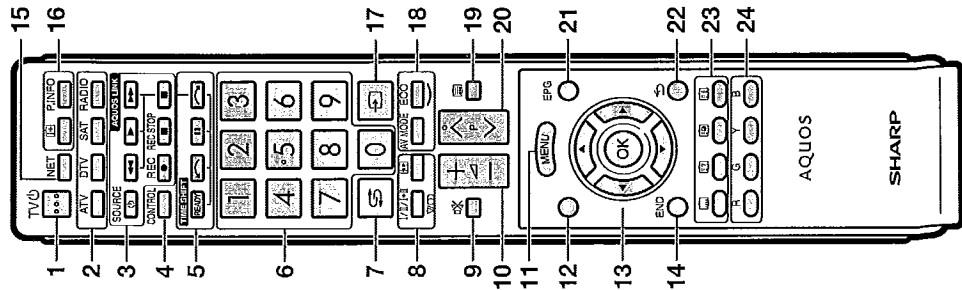

- 1 **TV/ON (Standby/On) (Page 19)**
- 2 **ATV**
Access conventional analogue TV mode.
- 3 **DTV**
Access digital TV mode.
- 4 **SAT**
Access satellite mode.
- 5 **RADIO**
DTV/SAT: Switch between radio and data mode.
• When only data broadcasting (no radio broadcasting) is transmitted by DVB, the radio broadcasting will be skipped.
- 6 **AQUOS LINK buttons (Pages 28 and 30)**
- 7 **CONTROL (Pages 47, 48, 52 and 61)**
Display a panel to operate some functions on the screen.
NET: "NET MENU" screen on/off.
- 8 **TIME SHIFT (READY) (Pages 47 and 48)**
Temporarily record a programme you are watching.
- 9 **Numeric buttons 0-9**
Set the channel. Enter desired numbers.
Set the page in teletext mode.
• When the five Nordic countries (Sweden, Norway, Finland, Denmark or Iceland) are selected in the country setting from initial auto installation (Page 14), DTV services are four digits. When another country is selected, DTV services are three digits.
- 10 **(Flashback)**
Return to the previously selected channel or external input.
- 11 **(Sound mode) (Page 20)**
Select a sound multiplex mode.
- 12 **(Wide mode) (Pages 41, 53 and 54)**
Select a wide mode.
- 13 **(Mute)**
TV sound on/off.
- 14 **+/- (Volume)**
Increase/decrease TV volume.
- 15 **MENU**
"Menu" screen on/off.
- 16 **None**
This button does not work on this model.
- 17 **▲/▼/◀/▶ (Cursor)**
Select a desired item.
OK
Execute a command.
ATV/DTV/SAT: Display "CH list" when no other "Menu" screen is running.
- 18 **END**
ATV/DTV/SAT: Exit the "Menu" screen.
NET: Return to the start page.
- 19 **NET**
Access Net TV.
- 20 **(Display information) (Page 20)**
Display the station information (channel number, signal, etc.) on the screen.
- 21 **P. INFO**
Display programme information transmitted through digital video broadcasting (DTV/SAT only).
- 22 **(INPUT) (Page 19)**
Select an input source.
- 23 **AV MODE (Page 32)**
Select audio/video settings.
ECO (Standard/Advanced/Off) (Page 35)
Select "Energy save" setting.
- 24 **(Teletext) (Page 23)**
ATV: Display analogue teletext.
DTV/SAT: Select MHEG-5 or teletext for DTV/SAT.
- 20 **P/V/V**
ATV/DTV/SAT: Select the TV channel.
NET: Scrolls pages up/down.
- 21 **EPG (Pages 21-23)**
DTV/SAT: Display the EPG screen.
- 22 **(Return)**
ATV/DTV/SAT: Return to the previous "Menu" screen.
NET: Return to the previous page (This may not function for some services).
- 23 **Buttons for useful operations**
(Subtitle) (Pages 23 and 40)
Switch subtitle languages on/off.
(Reveal hidden teletext) (Page 23)
(Subpage) (Page 23)
(Freeze/Hold) (Page 23)
Freeze a moving image on the screen.
Teletext: Stop updating teletext pages automatically or release the hold mode.
- 24 **R/G/Y/B (Colour) buttons**
The coloured buttons are correspondingly used to select the coloured items on the screen (e.g., EPG, MHEG-5, teletext).

Important information:
Satellite services are only available for the 635 model series.

Operation Manual (Continued)

Part names and functions

TV (front/side view)

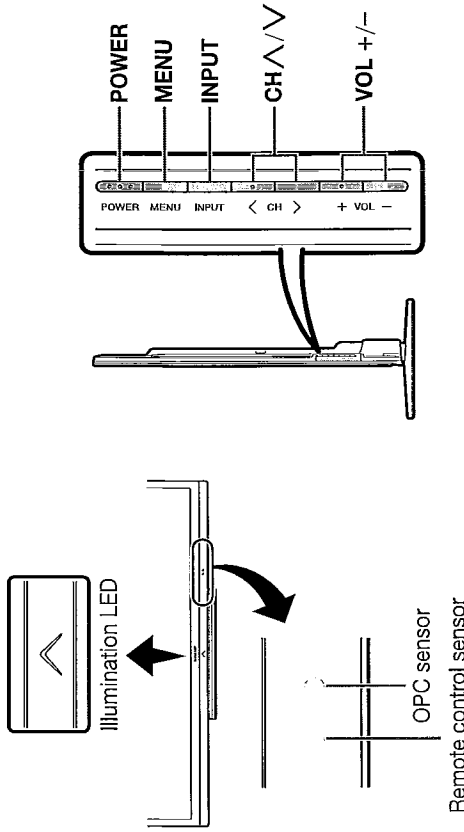

TV (rear view)

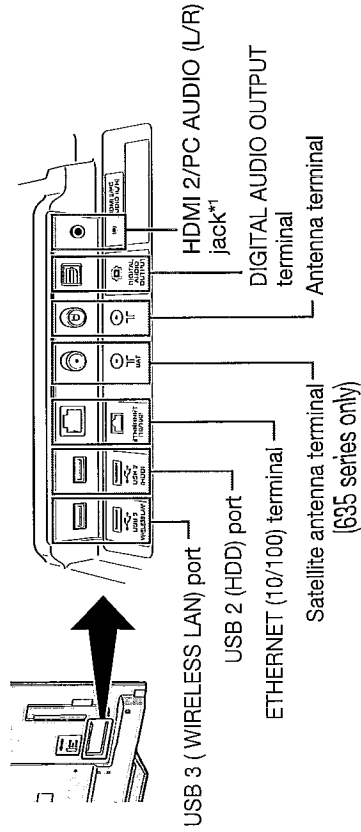

TV (rear view) — continued

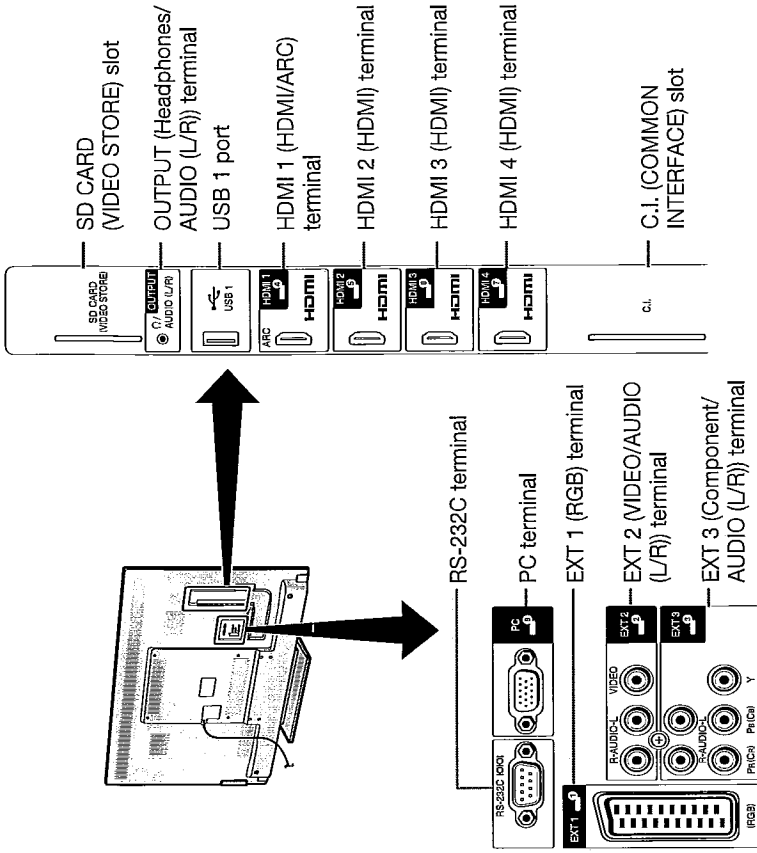

WARNING

- Excessive sound pressure from earphones and headphones can cause hearing loss.
- Do not set the volume at a high level. Hearing experts advise against extended listening at high volume levels.

Important information:

Satellite services are only available for the 635 model series.

*1 The HDMI 2 and PC terminals can both use the same audio input terminal (HDMI 2/PC AUDIO (L/R)). However, the proper item must be selected in the "Audio select" menu (refer to page 42 for details).

Connecting external devices

Introduction to connections

The TV is equipped with the terminals as shown below. Find the cable corresponding to the TV's terminal and connect the device.

- **Before connecting ...**
- Be sure to turn off the TV and any devices before making any connections.
- Firmly connect a cable to a terminal or terminals.
- Carefully read the operation manual of each external device for possible connection types. This also helps you get the best possible audiovisual quality to maximise the potential of the TV and the connected device.

Connection method for other devices

- **PC** → Page 54
- **USB device** → Page 46
- **Internet** → Pages 59 and 60

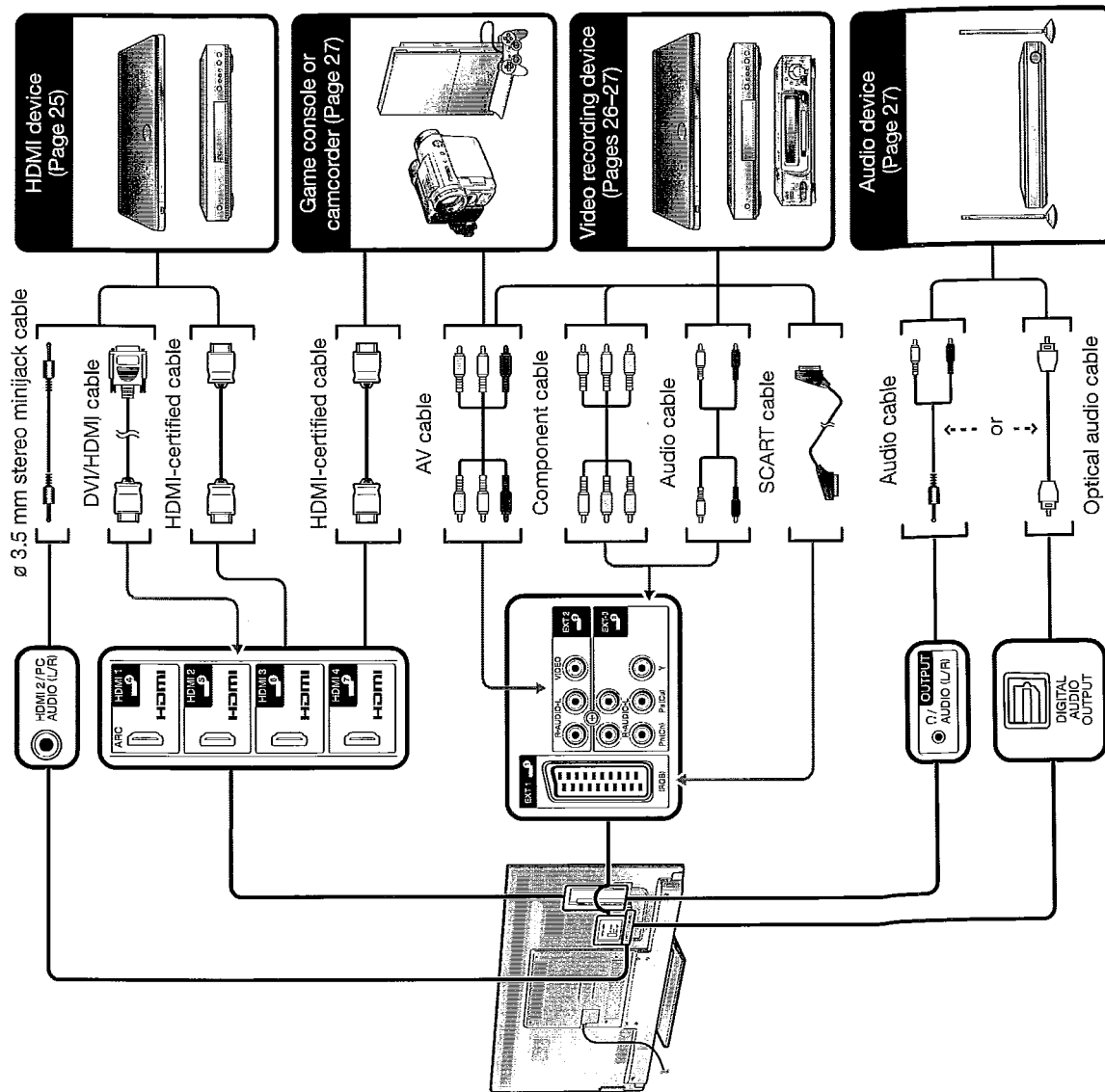

Other useful features

Using a USB device

The TV provides you some functions using a USB device. You can select which function to use after inserting a USB device in the USB port, and the TV starts the settings for each function.

USB usage

- Storage device for time shift
- USB media to enjoy photos, music and videos

Connecting a USB device

Connect a USB device to the TV as shown below.

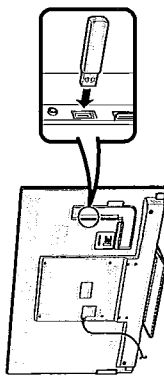

NOTE

- Some USB devices may not work properly for this function.
- Directly connect the USB storage device for time shift to the USB port.
- Do not connect and disconnect a USB device from the TV repeatedly.

Selecting USB usage

You need to select which function a USB device is used for when the USB device is inserted in the USB port.

- 1 Connect a USB device to one of the USB ports.
 - The screen prompt pops up.

NOTE

- If a USB storage device is inserted during time shift operation, a screen prompt will not pop up.
- 2 Select the function you want to use. Press **◀/▶**, and then press **OK**.



NOTE

- When you want to configure a software update, you need to press **END** to close the window.

For time shift

You need to complete the following procedure to use the USB storage device for time shift. After selecting "Time shift", the TV starts initializing the USB storage device. Follow the screen prompt to complete the setting.

- 1 Press **◀/▶** to select "Yes", and then press **OK**.
 - Reconfirm use of the USB storage device for time shift.

NOTE

- When you have inserted two or more USB storage devices in the ports, an error message appears. Insert only one USB storage device for time shift.
- You can also set the USB storage device to be used for time shift in the "Device registration" menu (Page 49).
- At least 1 GB is required for a USB storage device for time shift.
- A USB HDD cannot be used as a USB storage device for time shift.

- 2 Press **◀/▶** to select "Yes", and then press **OK**.
 - The TV starts initializing the USB storage device.
 - Delete the data in the USB storage device.

NOTE

- Do not disconnect the USB storage device when the TV is recognizing the memory for time shift.

- 3 Select "OK".
 - Press **OK**.

NOTE

- If an error message is displayed on the screen, follow the screen prompts and remove the USB storage device.

- ➔ Go to **Time shift** on page 47.

For USB media

After selecting "USB media", the TV switches to the USB media.

- ➔ Go to **USB media/Home network** on page 50.

NOTE

- Depending on the USB device, the TV may not be able to recognise the contained data.
- Use only alphanumeric characters for naming files.
- File names over 80 characters (may vary depending on the character set) may not be displayed.
- Do not disconnect a USB device or memory card from the TV while transferring files, using the slide show function, when a screen is switching to another or before you exit "USB media" from the "INPUT" menu.

Disconnecting the USB device

When you disconnect the USB device, be sure to the following steps.

For time shift

Go to "Menu" > "Setup" > "Option" > "Time shift setting" > "Device removal".

NOTE

- This menu item cannot be selected when a USB storage device for time shift is not registered.
- The USB storage device registration for time shift is cancelled in the following cases:
 - When the USB storage device is removed.
 - When another USB storage device is registered for time shift; only one USB device can be registered for time shift.

For USB media

- 1 Press **B** on the remote control unit.
 - Display "USB media menu".
- 2 Press **▲/▼** to select "USB device removal", and then press **OK**.
- 3 Press **◀/▶** to select "Yes", and then press **OK**.

Watching TV

Teletext



What is teletext?

Teletext broadcasts pages of information and entertainment to specially equipped TV. Your TV receives teletext signals broadcast by a TV network, and decodes them into graphical format for viewing. News, weather and sports information, stock exchange prices and programme previews are among the many services available.

Turning teletext on/off

- 1 Select a TV channel or external source providing a teletext programme.
- 2 Press  to display the teletext.
 - Many stations use the TOP operating system, while some use FLOF (e.g., CNN). Your TV supports both these systems. The pages are divided into topic groups and topics. After switching on the teletext, up to 2,000 pages are stored for fast access.
 - If you select a programme with no teletext signal, "No Teletext available" displays.
 - The same message displays during other modes if no teletext signal is available.







- Each time you press , the screen switches as shown above.
- Press  again to display the teletext on the right screen and the normal image on the left screen.

NOTE

- Teletext will not work if the selected signal type is RGB (Page 43).
- Teletext will not work when  is used for MHP services.

Buttons for teletext operations

Buttons	Description
	Increase or decrease the page number.
Numeric buttons 0-9	Directly select any page from 100 to 899 by using the 0-9 numeric buttons.
Colour (R/G/Y/B)	Select a group or block of pages displayed in the coloured brackets at the bottom of the screen by pressing the corresponding colour (R/G/Y/B) on the remote control unit.
 (Reveal hidden teletext)	Reveal or hide hidden information such as an answer to a quiz.
 (Freeze/hold)	Stop updating teletext pages automatically or release the hold mode.
 (Subtitle for teletext)	Display the subtitle or exit the subtitle screen. <ul style="list-style-type: none"> • Subtitles will not be displayed when the service does not contain subtitle information.
 (Subpage)	Reveal or hide subpages. <ul style="list-style-type: none"> • Move to the previous subpage (R). • Move to the following subpage (G). • These two buttons are shown on the screen by the symbols "+ " and "- ".
OK	Display the top menu. <ul style="list-style-type: none"> • The top menu will not be displayed when the service does not support top menus.

MHP application (Italy only)

If the TV is installed for Italy, MHP (Multimedia Home Platform) is active. If the channel you are currently watching provides MHP service, you can enjoy a variety of MHP services.

NOTE

- You can view some MHP content even if you do not perform "Network setup". Furthermore, "Network setup" allows you to view additional content such as interactive content from "Menu" > "Setup" > "View setting" > "Network setup".

View setting
Data service setting

Set the MHP service starting settings ("Auto", "Manual", "Off").

Go to "Menu" > "Setup" > "View setting" > "Data service setting".

NOTE

- If "Data service setting" is set to "Auto", the TV will load the MHP pages automatically.
- To avoid automatic loading, you can set to "Manual" or "Off".
- Subtitles for teletext may not display when MHP service is started. In such cases, set to "Off".



Open MHP pages

If the channel you are currently watching provides data service, you can enjoy MHP content.



When "Data service setting" is set to "Auto"

Press **R** to display the data service screen.

When "Data service setting" is set to "Manual"

- 1 Press **APP** to display the MHP application list.
- 2 Press  /  to select a desired service, and then press **OK**.
- 3 Press **R** to display the data service screen.

Using data service

- 1 Press  /  to select a desired option, and then press **OK**. The selected service will be started.

NOTE

- Operations vary depending on the MHP application.
- If a certain function appears on the screen, you can use the offered function by pressing the colour buttons.
- Text can be inputted using the numbers and letters printed on the numeric buttons on the remote control unit.

- 2 If you press **END**, data service will close.

Operation Manual (Continued)

Appendix

Troubleshooting

Problem	Possible solution
<ul style="list-style-type: none"> No power. The TV cannot be operated. Remote control unit does not operate. 	<ul style="list-style-type: none"> Is the AC cord disconnected? Check if you pressed POWER on the TV. External influences such as lightning, static electricity, etc., may cause improper operation. In this case, operate the TV after first turning off the power, or unplugging the AC cord and re-plugging it in after one or two minutes. Are batteries inserted with polarity (+, -) aligned? Are batteries worn out? (Replace with new batteries.) Are you using it under strong or fluorescent lighting? Is a fluorescent light illuminating to the remote control sensor?
Picture is cut off.	<ul style="list-style-type: none"> Is the image position correct? Are screen mode adjustments (Wide mode) such as picture size made correctly? (Pages 41, 53 and 54)
Strange colour, light colour, or dark colour, or colour misalignment.	<ul style="list-style-type: none"> Adjust the picture tone. Is the room too bright? The picture may look dark in a room that is too bright. Check the "Colour system" setting (Pages 38 and 43).
Power is suddenly turned off.	<ul style="list-style-type: none"> The TV's internal temperature has increased. Remove any objects blocking the vent or clean. Is the "Sleep timer" set? Select "Off" from the "Sleep timer" menu (Page 35). Is "No signal off" or "No operation off" activated? (Page 35)
No picture.	<ul style="list-style-type: none"> Are connections to external equipment correct? (Pages 24-29) Is the input signal type selected correctly after connection? (Page 43) Is the correct input source selected? (Page 19) Is a non-compatible signal being input? (Page 56) Is the picture adjustment correct? (Pages 32-33) Is the antenna connected properly? (Page 9) Is "On" selected in "Audio only"? (Page 35)
No sound.	<ul style="list-style-type: none"> Is the volume too low? If you do not clearly hear the sound for the visually impaired, go to "Menu" > "Setup" > "Audio" > "Audio description setting" > "Mix level", and select the upper level to turn up the volume. Make sure that headphones are not connected. Check if you pressed OK on the remote control unit.

No sound. (continued)	<ul style="list-style-type: none"> Is the proper item selected in the "Audio select" menu when connecting devices to the HDMI 2 terminal or the PC terminal? (Pages 25, 27 and 42)
The TV sometimes makes a cracking sound.	<ul style="list-style-type: none"> This is not a malfunction. This happens when the cabinet slightly expands and contracts according to changes in temperature. This does not affect the TV's performance.

Reset the PIN

- Go to "Menu" > "Setup".
- Press **▲/▼** to select "Auto installation", "Programme setup", "PIN", "Parental rating" or "Reset", and then press **OK**. The PIN input window will display.
- Press and hold both **CH/▲** and **VOL+** on the TV simultaneously until the message appears on the screen.

NOTE

- When the PIN code is reset, the default PIN code ("1234") is set.
- The PIN is also available for the Net TV function.

Reset

If complex adjustments are made so that the settings cannot be restored to normal, you can reset the settings to the factory preset values.

- Go to "Menu" > "Setup" > "View setting" > "Reset".
- Press **◀/▶** to select "Yes", and then press **OK**.
 - "Now, TV will restart automatically, OK?" displays on the screen.
- Press **◀/▶** to select "Yes", and then press **OK**.
 - "Now initialising..." displays on the screen and blinks.
 - After the reset has completed, the power shuts off and then comes back on. The screen will have returned to its original settings.

NOTE

- PIN input is required when executing "Reset". The default PIN is "1234". To change the PIN setting, refer to **Individual setting - PIN** (Page 39). To reset the PIN setting (PIN input will no longer be needed), refer to **Reset the PIN** shown above.

DIMENSIONS

Appendix

Dimensional drawings

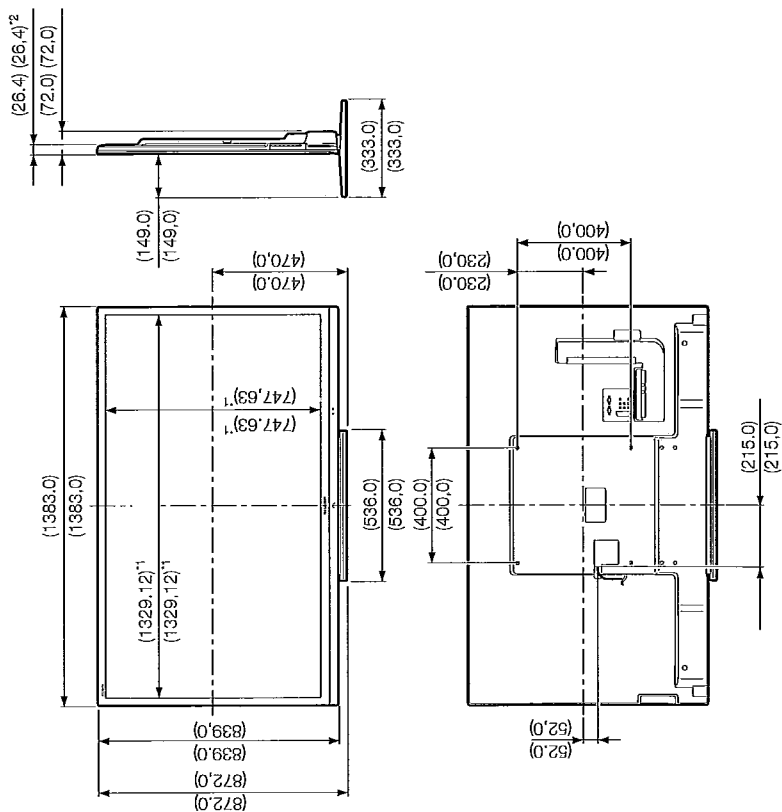

*1 Active area

*2 Thinnest part



NOTE

- Dimensions do not include protrusions such as screws and some parts.

60"

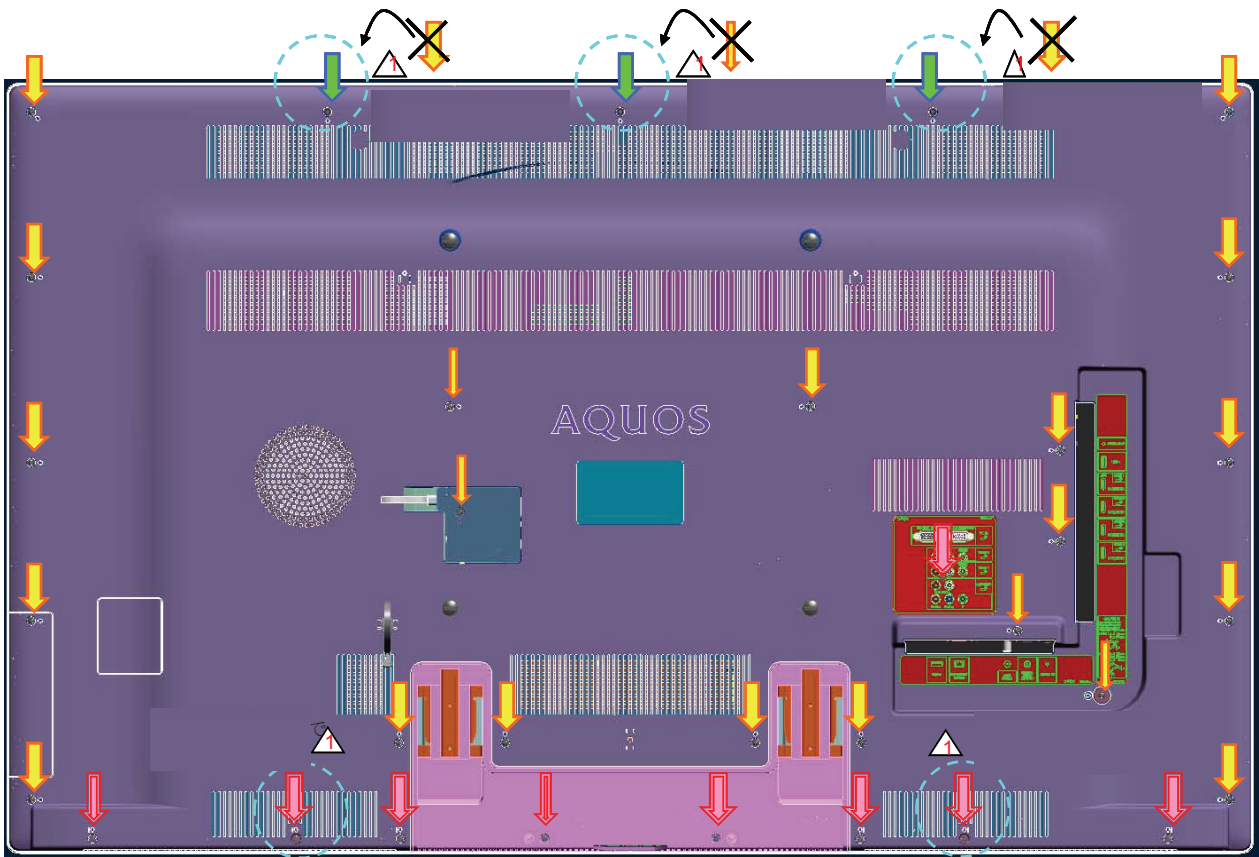
1



-  XBPS830P06WS0 21pcs
-  LX-BZA401WJN1 3pcs
-  XEBS830P12000 9pcs

2

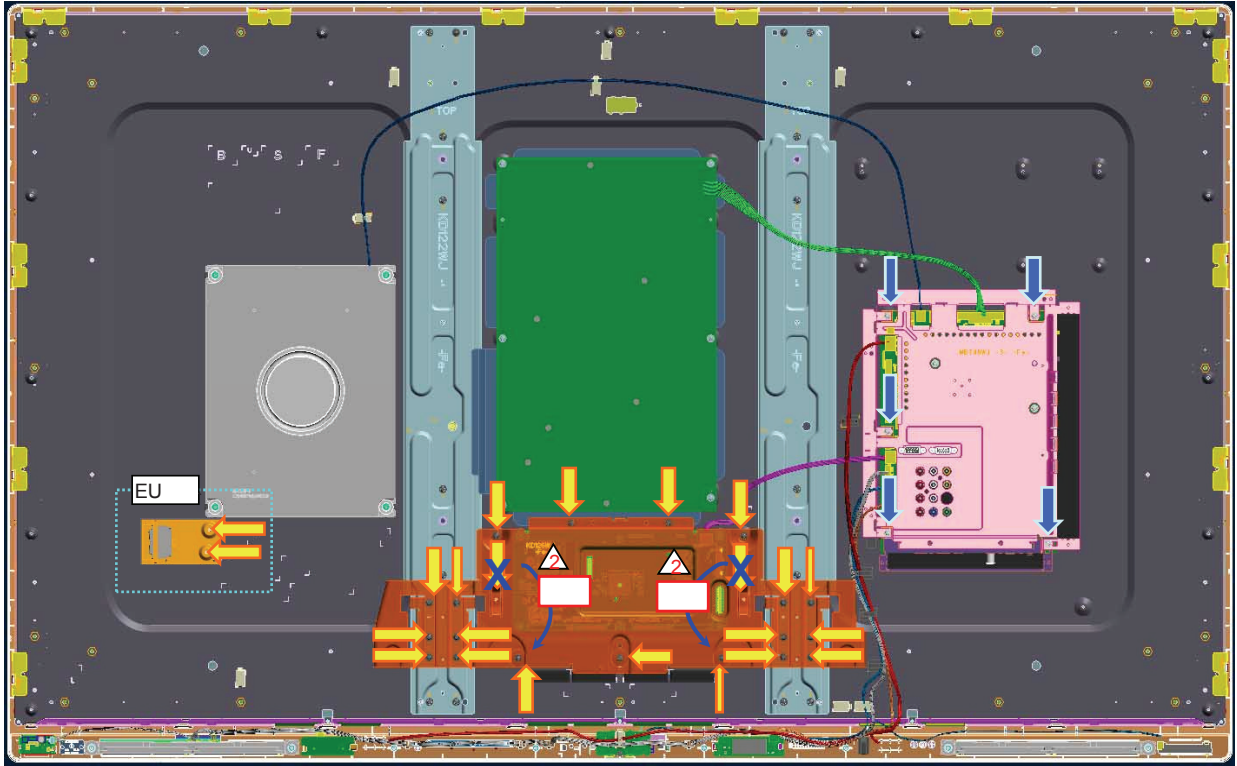

→ XBPS830P06WS0 21(EU) 19(US)

→ LX-BZA207WJF7 5pcs

3

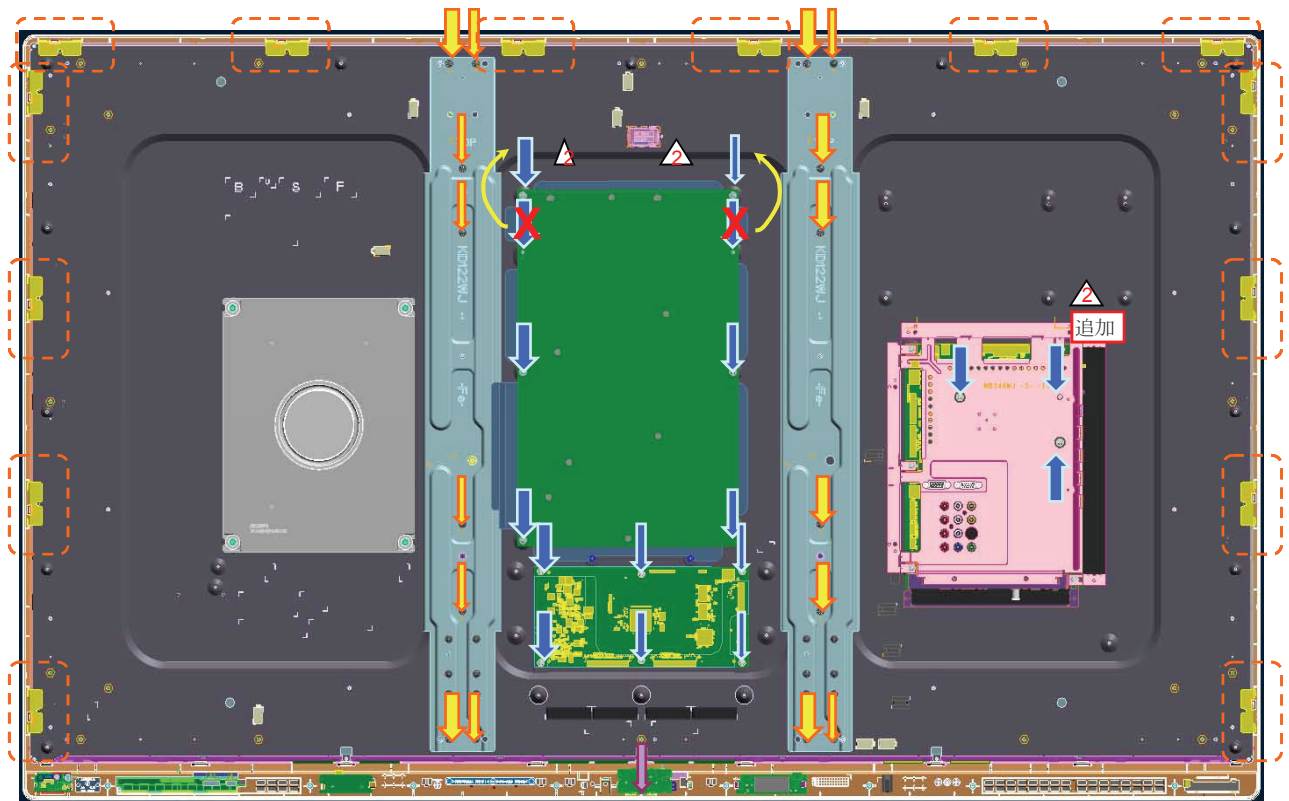

LANGKD127WJFW 14pcs

→ XBPS830P06WS0 16pcs

→ LX-BZA207WJF7 15pcs

→ XEBS830P08000 1pc

SERVICE ADJUSTMENTS

1. Adjustment method after PWB and/or IC replacement due to repair

The unit is set to the optimum performance at the time of shipment from the factory.

If any value should become improper or any adjustment is necessary due to the part replacement, make an adjustment according to the following procedure.

1.1. Procure the following units in order to replace the main unit:

MAIN UNIT **DUNTKF733FM55(LC60LE635E) / DUNTKF733FM57(LC60LE638E)**

NOTE: [Caution when replacing ICs in the main unit (IC2001, IC8401 and IC3303)]

Before replacing the relevant part, procure the following parts in which the data have been rewritten.

Ref.	Description	Parts code IC
IC2001	Monitor microcomputer	RH-IXD241WJQZQ
IC8401	Flash	RH-IXD287WJQZQ
IC3303	Main CPU	RH-IXD220WJQZQ

NOTE: HDMI ROM Writing

After replacing IC1504, execute "HDMI EDID WRITE" on the page 5/23.

Please execute it after checking MODEL NAME & INCH SIZE are correct.

If MODEL NAME & INCH SIZE are not correct, set them previously. (Refer to 2.)

The ROM data based on information of MODEL NAME & INCH SIZE

- 1) Enter the process adjustment mode in TV.
- 2) Use the cursor keys (▲/▼) and CH keys (√/∧) of R/C to select the item [HDMI EDID WRITE] on the page 5/23.
- 3) It is completed with OK displayed.

NOTE: PC ROM Writing

After replacing IC1504, execute "PC EDID WRITE" on the page 5/23.

Please execute it after checking MODEL NAME & INCH SIZE are correct

If MODEL NAME & INCH SIZE are not correct, set them previously. (Refer to 1.2.)

The ROM data based on information of MODEL NAME & INCH SIZE

- 1) Enter the process adjustment mode in TV.
- 2) Use the cursor keys (▲/▼) and CH keys (√/∧) of R/C to select the item [PC EDID WRITE] on the page 5/23.
- 3) It is completed with OK displayed.

1.2. After replacing the LCD panel or LCD control/MAIN UNIT, check MODEL NAME in the following procedure.

- 1) Enter the process adjustment mode in TV.
- 2) Use the cursor keys (▲/▼) and CH keys (√/∧) of R/C to select the item [MODEL NAME] on the page 23/23.
- 3) Verify that the Model name is displayed.
- 4) If the Model name doesn't match, select the values of the Model name with the VOL keys(+/-).
- 5) After selection in Step 4), press the OK key, and it is completed with OK displayed.
- 6) Use the cursor keys (▲/▼) and CH keys (√/∧) of R/C to select the item [PANEL_SIZE] on the page 23/23.
- 7) Verify that the panel size is displayed.
- 8) If the size doesn't match, select the values of the panel size with the VOL keys(+/-).
- 9) After selection in Step 8), press the OK key, and it is completed with OK displayed.

1.2. After replacing the LCD panel or LCD control PWB, adjust the VCOM in the following procedure.

- 1) Enter the process adjustment mode.
- 2) Use the cursor keys (▲/▼) and CH keys (∨/∧) of R/C to select the item [VCOM ADJ] on the page 10.
- 3) Press the OK key to verify that the adjustment pattern is displayed.
- 4) Use VOL keys(+/-) of R/C to adjust the flicker in the center of the screen to minimum.
- 5) When the optimal state is achieved in Step 4, press the OK key to turn the pattern to OFF.

2. Method of shuts down for Power supply

Please execute the following procedures to shut down Power supply from the state of normal operation.

- 1) Keep touching the power supply key on the set for 5 seconds from the state of watching.
The screen disappears when power supply key is touched, but Keep pushing the power supply key.
- 2) A central icon lights between 500ms when the power supply shuts down.
Please separate the finger from the power supply key when lighting of a central icon is confirmed

3. Entering and exiting the adjustment process mode.

Please execute the following procedures to enter the adjustment process mode when the power supply shuts down.

1. Press and hold "V-" and "→" keys, simultaneously and touch the power supply key on the set.
Please separate the fingers from key on the set when boot-up is confirmed with lighting of a central icon etc.
After a while, The letter "K" appears on the screen. This state is in Inspection mode.
2. Next, hold down the "VOL -" and "P -" keys on the set at once.
Multiple lines of blue characters appearing on the screen indicate that the set is now in the adjustment Process mode.
If you fail to enter the adjustment process mode (the display is the same as normal startup), retry the procedure.
3. To exit the adjustment process mode after the adjustment is done, unplug the AC power cord to force off the power.
(When the power is turned off with the remote controller, once unplug the AC power cord and plug it in again.
In this case, wait for 10 seconds or so after unplugging.)

5. Remote control key operation and description of display in adjustment process mode.

1. key operation

Remote control key	Keyboard unit	Function
CH keys (▲/▼)	CH (▲/▼)	Moving an item (line) by one (UP/DOWN)
VOL keys (+/-)	VOL (+/-)	Changing a selected item setting (+1/-1)
Cursor (▲/▼)	-	Turning a page (PREVIOUS / NEXT)
Cursor (◀/▶)	-	Changing a selected line setting (+10/-10)
	INPUT	Input source switching (toggle switching) (TV→EXT1→ etc...)
OK	-	Executing a function.
RETURN	-	Returning to a present page.

The required input mode should be switched previously to enter the Service Mode.

CAUTION: Use due care in handling the information described here lest the users should know how to enter the adjustment process mode. If the settings are tampered with in this mode, unrecoverable system damage may result.

6. Description of display

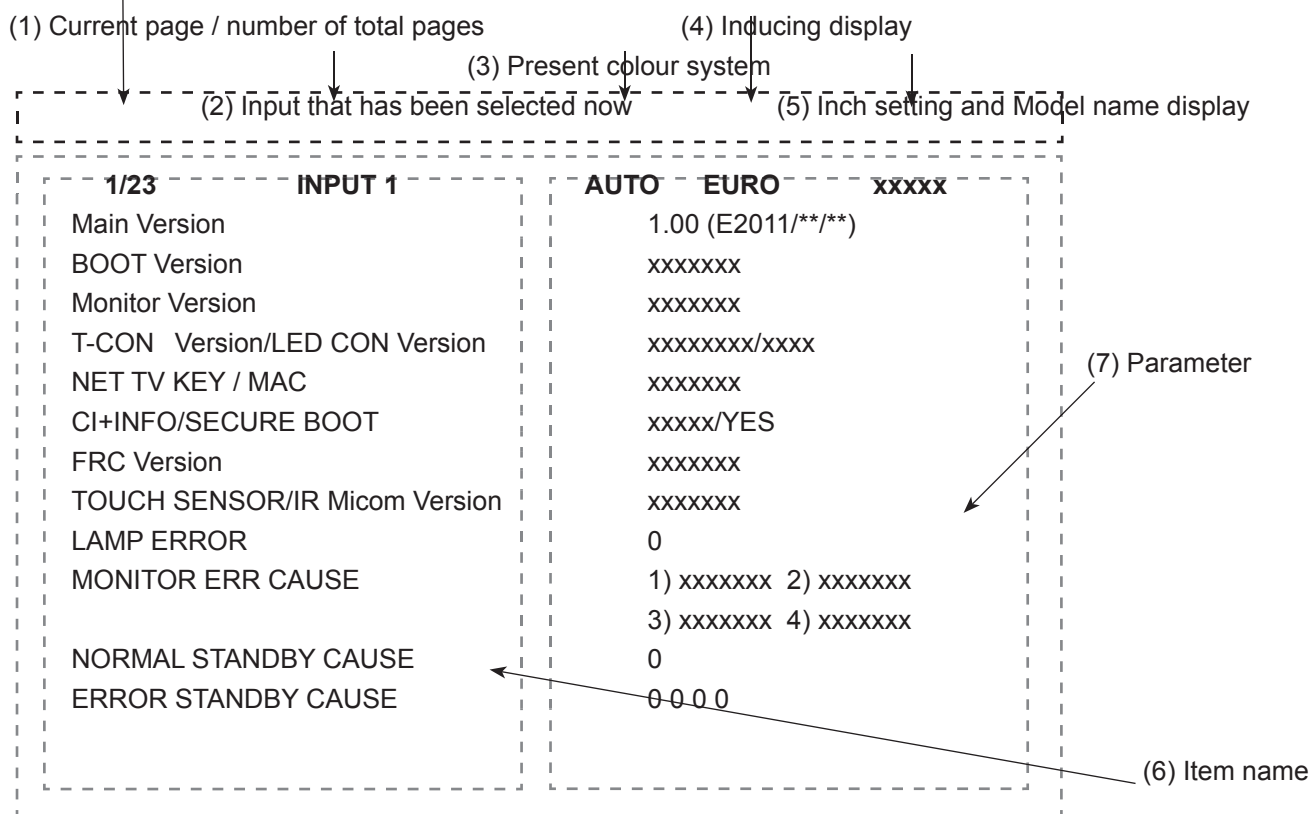

No.	Description	Display specification
(1)	Present page/number of total pages	2char/2char Decimal Number mark.
(2)	Input that has been selected now	TUNER/DTV/INPUT1/INPUT2/INPUT3/INPUT5/INPUT6/INPUT7/etc...
(3)	Present colour system	AUTO/N358/N443/PAL/SECAM/480i/580i/1080i/50 etc...
(4)	Inducing display	EUROPE / RUSSIA / SWEDEN
(5)	Inch setting and Model name display	Inch setting and Model name display
(6)	Item name	Max. 30 char
(7)	Parameter	Max. 60 char

7. Adjustment process mode menu

The character string in brackets [] will appear as a page title in the adjustment process menu header.

Page	Line	Item	Description	Remarks (adjustment detail, etc.)
1/23				
	1	MAIN Version	1xxx (xxxxx)	Main software version
	2	BOOT Version	xxxxxxx	BOOT Version.
	3	Monitor Version	xxxxxxx	Monitor software version
	4	T-CON Version/LED CON Version	xxxxxxx/xxxx	T-CON/LED CON Version
	5	NET TV KEY/MAC	xxxxxxx	NET TV KEY/MAC Address
	6	CI+INFO/SECURE BOOT	xxxxx/YES	CI+ Key Information/SECURE BOOT
	7	FRC Version	xxxxxxx	
	8	TOUCH SENSOR/IR Micom Version	xxxxxxx	
	9	LAMP ERROR	0	Number of termination due to lamp error.
	10	MONITOR ERR CAUSE	1)xxxxxx 2)xxxxxx 3)xxxxxx 4)xxxxxx	Last error standby cause.
	11	NORMAL STANDBY CAUSE	0	Situation that became standby at the end. (Excluding the error)
	12	ERROR STANDBY CAUSE	0 0 0 0	Error standby cause
2/23				
	1	INDUSTRY INIT	Enter	Initialization to factory settings execution.
	2	INDUSTRY INIT (-Public)	OFF	Initialization to factory settings execution. (Public mode is excluded)
	3	PUBLIC MODE	OFF	Public mode ON/OFF setting
	4	Center Acutime	—	Main operating hours.
	5	RESET	OFF	Main operating hours reset.
	6	Backlight Acutime	—	Backlight operating hours.
	7	RESET	OFF	Backlight operating hours reset.
	8	LAMP ERROR RESET	OFF	Lamp error reset.
	9	ADJ PARAM SET	Enter	ADJ PARAM SET
	10	VIC XPOS	0	X-coordinate setting for VIC READ
	11	VIC YPOS	0	Y-coordinate setting for VIC READ
	12	VIC SIGNAL TYPE	MAIN	Signal type setting for VIC READ
	13	VIC READ	OFF	Picture level acquisition function. (Level appears in green on the upper right)
3/23				
	1	TUNER ADJ	Enter	TUNER auto adjustment execution
	2	PAL+TUNER ADJ	Enter	PAL TUNER auto adjustment execution
	3	TUNER ADJ (SMPTE)	Enter	TUNER auto adjustment execution (SMPTE)
	4	PAL+TUNER ADJ (SMPTE)	Enter	PAL TUNER auto adjustment execution (SMPTE)
	5	TUNER ADJ (SMPTE CH57)	Enter	TUNER auto adjustment execution (SMPTE CH57)
	6	PAL+TUNER ADJ (SMPTE CH57)	Enter	PAL TUNER auto adjustment execution (SMPTE CH57)
	7	TUNER CONTRAST A_GAIN	14	TUNER signal level adjustment
	8	TUNER CONTRAST D_GAIN	2048	TUNER signal level adjustment
	9	TUNER CONTRAST OFFSET	256	TUNER signal level adjustment
4/23				
	1	PAL ADJ	Enter	PAL adjustment
	2	SECAM ADJ	Enter	SECAM adjustment
	3	N358 ADJ	Enter	N358 adjustment
	4	PAL CONTRAST A_GAIN	14	PAL contrast adjustment
	5	PAL CONTRAST D_GAIN	2048	PAL contrast adjustment
	6	PAL CONTRAST OFFSET	256	PAL contrast adjustment
	7	SECAM CONTRAST A_GAIN	14	SECAM contrast adjustment
	8	SECAM CONTRAST D_GAIN	2048	SECAM contrast adjustment
	9	SECAM CONTRAST OFFSET	256	SECAM contrast adjustment
	10	N358 CONTRAST A_GAIN	14	N358 contrast adjustment
	11	N358 CONTRAST D_GAIN	2048	N358 contrast adjustment
	12	N358 CONTRAST OFFSET	256	N358 contrast adjustment
5/23				
	1	HDMI CEC TEST	Enter	HDMI CEC test
	2	INSPECT USB TERM	Enter	Reading inspection of USB memory terminal
	3	HDMI EDID WRITE	Enter	HDMI EDID WRITING
	4	MONIDATA READ [TEMP/OPC]	OFF	MONITOR Temperature/OPC Acquisition tool.
		SD CARD TEST	Enter	SD CARD TEST
	5	CAUSE RESET	Enter	Reset of standby cause

7. Adjustment process mode menu (continued)

Page	Line	Item	Description	Remarks (adjustment detail, etc.)
6/23				
	1	COMP15K ALL ADJ	Enter	Component 15K picture level adjustment
	2	COMP15K MAIN Y GAIN	140	Y GAIN adjustment value
	3	COMP15K MAIN CB GAIN	150	Cb GAIN adjustment value
	4	COMP15K MAIN CR GAIN	150	Cr GAIN adjustment value
	5	COMP15K Y OFFSET	64	Y OFFSET adjustment value
	6	COMP15K CB OFFSET	128	Cb OFFSET adjustment value
	7	COMP15K CR OFFSET	128	Cr OFFSET adjustment value
7/23				
	1	HDTV ADJ	Enter	HDTV video level adjustment
	2	HDTV Y GAIN	140	HDTV Y GAIN adjustment value
	3	HDTV CB GAIN	150	HDTV Cb adjustment value
	4	HDTV CR GAIN	150	HDTV Cr adjustment value
	5	HDTV Y OFFSET	64	HDTV Y OFFSET adjustment value
	6	HDTV CB OFFSET	128	HDTV Cb OFFSET adjustment value
	7	HDTV CR OFFSET	128	HDTV Cr OFFSET adjustment value
8/23				
	1	ANALOG PC ADJ	Enter	DVI ANALOG video level adjustment
	2	R OFFSET	64	R CUTOFF adjustment value
	3	G OFFSET	64	G CUTOFF adjustment value
	4	B OFFSET	64	B CUTOFF adjustment value
	5	R GAIN	44	R DRIVE adjustment value
	6	G GAIN	44	G DRIVE adjustment value
	7	B GAIN	44	B DRIVE adjustment value
9/23				
	1	SCART RGB ADJ	Enter	SCART RGB level adjustment
	2	SCART RGB ADJ (FASTSW)	Enter	SCART RGB ADJ (FASTSW) adjustment
	3	SCART R CUTOFF	64	SCART R CUTOFF adjustment value
	4	SCART G CUTOFF	64	SCART G CUTOFF adjustment value
	5	SCART B CUTOFF	64	SCART B CUTOFF adjustment value
	6	SCART R GAIN	44	SCART R GAIN adjustment value
	7	SCART G GAIN	44	SCART G GAIN adjustment value
	8	SCART B GAIN	44	SCART B GAIN adjustment value
10/23				
	1	VCOM ADJ (2D)	0	Common bias adjustment (2D)
11/23				
	1	R GAIN (LO)	0	R DRIVE adjustment value
	2	G GAIN (LO)	0	G DRIVE adjustment value
	3	B GAIN (LO)	0	B DRIVE adjustment value
	4	R GAIN (HI)	0	R DRIVE adjustment value
	5	G GAIN (HI)	0	G DRIVE adjustment value
	6	B GAIN (HI)	0	B DRIVE adjustment value
12/23				
	1	MONITOR TIME OUT	ON	Monitor and the main communication time-out setting
	2	MONITOR MAX TEMP	45	MONITOR MAX temperature setting
	3	MONITOR EEP READ/WRITE	WRITE	MONITOR EEPROM READ/WRITE Setting/execution
	4	MONITOR EEP ADR	0x 0	MONITOR EEPROM arbitrary addressing
	5	MONITOR EEP DATA	0x 0	MONITOR EEPROM arbitrary data specification
13/23				
	1	LCD TEST PATTERN	OFF	Pattern with built-in LCD controller display
	2	LCD TEST PATTERN1	OFF	
	3	LCD TEST PATTERN2	OFF	
	4	LCD TEST PATTERN3	OFF	
	5	LCD TEST PATTERN4	OFF	
14/23				
	1	TCON Version EXT.1	xxxxx	
	2	TCON Version EXT.2	xxxxx	
	3	TCON Version EXT.3	xxxxx	
	4	TCON Version EXT.4	xxxxx	

7. Adjustment process mode menu (continued)

Page	Line	Item	Description	Remarks (adjustment detail, etc.)
15/23				
	1	3DHDMI FPGA Version	xxxxx	
	2	2D→3D FPGA Version	xxxxx	
	3	3D IR EMITTER CONTROL	xxxxx	
16/23				
	1	POWER LED BRIGHTNESS	0	
	2	MENU LED BRIGHTNESS	0	
	3	INPUT LED BRIGHTNESS	0	
	4	CH UP LED BRIGHTNESS	0	
	5	CH DOWN LED BRIGHTNESS	0	
	6	VOL UP LED BRIGHTNESS	0	
	7	VOL DOWN LED BRIGHTNESS	0	
	8	LOGO LED BRIGHTNESS	99	
	9	ICON LED BRIGHTNESS	99	
	10	ICON LED BRIGHTNESS (STANDBY)	30	
	11	3D LED BRIGHTNESS	30	
17/23				
	1	POWER KEY SENSITIVITY	0	
	2	MENU KEY SENSITIVITY	0	
	3	INPUT KEY SENSITIVITY	0	
	4	CH UP KEY SENSITIVITY	0	
	5	CH DOWN KEY SENSITIVITY	0	
	6	VOL UP KEY SENSITIVITY	0	
	7	VOL DOWN KEY SENSITIVITY	0	
18/23				
	1	KEY STRENGTH GET MODE	Enter	
	2	POWER KEY STRENGTH		
	3	MENU KEY STRENGTH		
	4	INPUT KEY STRENGTH		
	5	CH UP KEY STRENGTH		
	6	CH DOWN KEY STRENGTH		
	7	VOL UP KEY STRENGTH		
	8	VOL DOWN KEY STRENGTH		
19/23				
	1	CROSSTALK ADJ MODE	Enter	
	2	CROSSTALK TH1		
	3	CROSSTALK TH2		
	4	CROSSTALK TH3		
	5	CROSSTALK TH4		
	6	CROSSTALK GAIN1		
	7	CROSSTALK GAIN2		
	8	CROSSTALK GAIN3		
20/23				
	1	READ/WRITE	READ	Read/Write
	2	SLAVE/ADDRESS	SLAVE0	Slave address
	3	REGISTER ADDRESS	0x 0 0x 0	Register address
	4	WRITE DATA	0x 0 0x 0	Writing data
	5	READ DATA	0x 0 0x 0	Reading data
21/23				
	1	RF AGC BG	6	RF-AGC BG adjustment execution
	2	RF AGC DK	5	RF-AGC DKG adjustment execution
	3	RF AGC I	6	RF-AGC I adjustment execution
	4	RF AGC L/L'	4	RF-AGC L/L' adjustment execution
22/23				
	1	ERROR STANDBY CAUSE1	NO RECORD	ERROR STANDBY CAUSE
	2	ERROR STANDBY CAUSE2	NO RECORD	
	3	ERROR STANDBY CAUSE3	NO RECORD	
	4	ERROR STANDBY CAUSE4	NO RECORD	
	5	ERROR STANDBY CAUSE5	NO RECORD	
	6	STANDBY CAUSE RESET	OFF	Reset stand by cause.

8. Special features

Page	Line	Item	Description	Remarks (adjustment detail, etc.)
23/23				
	1	EEP SAVE	OFF	Writing setting values to EEPROM.
	2	EEP RECOVER	OFF	Reading setting values from EEPROM.
	3	MONITOR ERROR CAUSE RESET	OFF	Reset of monitor error cause
	4	MODEL NAME	LE830E	MODEL NAME
	5	PANEL SIZE	52	Panel size setting.
	6	PANEL LIMIT	ON	PANEL LIMIT
	7	PANEL RANGE LIMIT	xxx	PANEL RANGE LIMIT
	8	SHORT CHECK MODE	Enter	Check LED Back light
	9	SHORT CHECK CURRENT	60	
	10	CURRENT SW	LOW	
	11	PRODUCT EEP ADR	0x 0	Don't touch when serving (for producer of factory)
	12	PRODUCT EEP DATA	0x 0	Don't touch when serving (for producer of factory)
	13	PRODUCT FACTORY	1	Don't touch when serving (for producer of factory)

8. Special features

1. NORMAL STANDBY CAUSE (Page 1/23)

Display of a cause (code) of the last standby.

The cause of the last standby is recorded in EEPROM whenever it is possible.

Checking this code will be useful in finding a problem when you repair the troubled set.

2. EEP SAVE (Page 23/23)

Storage of EEP adjustment value

3. EEP RECOVER (Page 23/23)

Retrieval of EEP adjustment value from storage area.

4. MONITOR ERR CAUSE (Page 1/23)

Display of a cause (code) of Error from Monitor microcomputer.

The cause of Error is recorded in EEPROM whenever it is possible.

Checking this code will be useful in finding a problem when you repair the troubled set.

1) This displays Error code and time when the error occurred.

The latest error is displayed on "1)".

The error that happens ahead of "1)" is displayed on "2)".

2) The character depends on the way how to acquire Time Information.

T: Time is acquired from digital broadcasting

This doesn't contain "Time offset" which is considered a time difference and Daylight-Saving Time, etc. ...

U: Time is acquired from analog broadcasting (teletext)

B: Accumulation time of Backlight

In the case that Time information cannot be acquired, "B" is displayed.

Example) In this example, it is shown that the error occurred 3 times.

- | | | |
|-----------------------|---|---|
| 1) 16 T07/01/01 12:03 | Error code: 16 (lamp error) | Time: 07/01/01 12:03 |
| | * It is latest Error. | |
| | * Time is acquired from digital broadcasting. | |
| | * Time is UTC which doesn't have Time offset. | |
| 2) 16 U01/01/01 04:07 | Error code: 16 (lamp error) | Time: 07/01/01 04:07 |
| | * It is Error that happens ahead of "1)". | |
| | * Time is acquired from analogue broadcasting. | |
| 3) 16 B00000004:11 | Error code: 16 (lamp error) | Accumulation time: It is displayed that 4:11 have passed after Backlight driving. |
| | * It is Error that happens ahead of "2)". | |
| 4) 00 00000000000000 | No error ("00" shows that the error is not occurred.) | |

9. Lamp Error detection

1. Function

This LCD color TV set incorporates a Lamp error detection feature that automatically turns off the power for safety under abnormal lamp or lamp circuit conditions. If by any chance anything is wrong with the lamp or lamp circuit or if the lamp error detection feature is activated for some reason, the following will result.

- 1) The power is interrupted in about 500ms after it is turned on.
(A central icon on the front of the TV flash on and off.: ON for 400ms and OFF for 1600ms.).
- 2) If the above phenomenon 1) occurs 5 times, it becomes impossible to turn on the power.
(A central icon keep flashing on/off.)

2. Measures

1) Set the lamp error detection to OFF

Enter the adjustment process mode, referring to "4. Entering and exiting the adjustment process mode."

The adjustment process mode can ignore "5 times count", so if the above phenomenon 1) occurs 1~4 times, the lamp will go out.

If Lamp Error detection pin [4pin of PD: P9602/19pin of IC2001] is "High" by a trouble with the lamp and lamp circuit, it can boot-up by the adjustment process mode.

Please execute "**Lamp Error detection off-mode**".

While holding down the "VOL (-)" and "CH (∧)" keys on the set at once, touch the power supply key on the set.

After a central icon flash off, separate the fingers from key on the set.

Then, you can check the operation to see if the lamp and lamp circuit are in trouble.

If you fail boot-up, retry the procedure.

2) Resetting the lamp error count

After the lamp and lamp circuit are improved from a trouble, reset the lamp error count.

(Because the power cannot be turned on, if a lamp error is detected 5 consecutive times)

- a) Enter the adjustment process mode, referring to "4. Entering and exiting the adjustment process mode."
- b) Using the cursor (▲/▼) key, move to the cursor to [LAMP ERROR RESET], Line 8 on adjustment process mode service page 2/23.
- c) With the cursor (◀/▶) keys, select the [LAMP ERROR RESET] value.
Finally press the cursor (OK)., the count is reset.
Check LAMP ERROR Count on adjustment process mode Page 2/23.

Table of contents of adjustment process mode Page 2/23

INDUSTRY INIT	Enter	
INDUSTRY INIT (-Publicl)	OFF	
PUBLIC MODE	OFF	
Center Acutime	—	
RESET	OFF	
Backlight Acutime	—	
RESET	OFF	
LAMP ERROR RESET	OFF	← Resetting to "0"
ADJ PARAM SET	Enter	
VIC XPOS	0	
VIC YPOS	0	
VIC SIGNAL TYPE	MAIN	
VIC READ	OFF	

10. Public Mode

1. Starting the Public Mode

- There are two following ways to display the PUBLIC Mode setting screen.

1) Method of needing password

- Turn off the power, refer to "3. Method of shuts down for Power supply"
- While holding down the "INPUT" and "Volume (+)" keys on the set at once, touch the power supply key on the set.
Please separate the finger from the power supply key when boot-up is confirmed with lighting of a central icon etc.
After a while, value of Enter password appears on the screen.
- Display the Pass Word input screen.

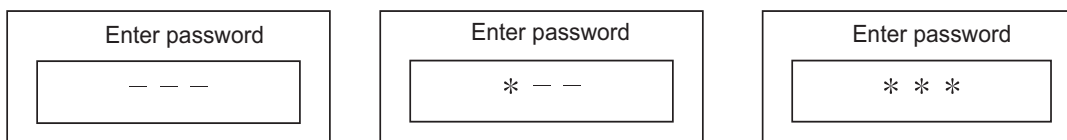

Operation procedure

- The initial input position is the digit at the left end.
- For the numeric keys "0" to "9" of R/C, key input is accepted.
Input of the other keys is prohibited.
- Change "—" to "*" by inputting the numeric key at the input position, and shift the input position rightward one digit.
- When three digits are completely input, the Pass Word is judged.

d) Check the Pass Word by inputting three digits.

If the Pass Word "0" "2" "7", it shifts to the PUBLIC Mode setting screen.

In another case, the screen is erased, and it operates in the ordinary mode.

2. Exiting the Public Mode Setting screen

- There are two following ways to exit the Public Mode setting screen.

1) Turn off the power.

2) Select "Execution" in the PUBLIC_Mode to execute it.

Activate the restart under the set content.

Here, the START input SOURCE setting is excluded since this item is referred to only when the power is turned on.

3. Set value of the Public Mode

- When the shipment setting is done, a set each value in Public Mode is initialized.
(PUBLIC MODE in the process mode Setting of a flag is also initialized)
- Separately, the shipment beginnings when all except for each set value in Public Mode is initialized are provided for a process mode. (INDUSTRY INIT (-Public))
- Only when turning on the PUBLIC MODE item, each setting is effective.
- After it decides it with EXECUTE, it AC OFF/ON it to reflect a set value.

4. Basic operation in the Public Mode

Vol (+/-) or Cursor (◀/▶)	Change or execution of the set value.
CH (+/-) or Cursor (▲/▼)	Movement to the selected item.
Decision (ok)	Excution (Used by the items "Execution" and "RESET".)

Public Mode setting screen.

Public Mode	
POWER ON FIXED	[VARIABLE]
SHUT DOWN MODE	[NORMAL]
MAXIMUM VOLUME	[60]
VOLUME FIXED	[VARIABLE]
VOLUME FIXED LEVEL	[20]
RC BUTTON	[RESPOND]
PANEL BUTTON	[RESPOND]
MENU BUTTON	[RESPOND]
AV POSITION FIXED	[VARIABLE]
ON SCREEN DISPLAY	[YES]
INPUT MODE START	[NORMAL]
INPUT MODE FIXED	[VARIABLE]
LOUD SPEAKER	[ON]
RC PATH THROUGH	[OFF]
232C POWON	[DISABLE]
PUBLIC MODE	[ON]
RESET	
EXECUTE	

10. Public Mode (continued)

5. Operation after "RESET"

Select "RESET" in the PUBLIC Mode, and it operates as follows when it is executed (refer to the basic operation).

- The set contents in the PUBLIC mode are initialized.
- It does not exit the PUBLIC mode.
- If "EXECUTE" is not executed, the content that does RESET is not reflected.

6. Setting items (* Item names and selective items are expressed in English.)

1) Power ON fixed [POWER ON FIXED]

Option	"VARIABLE", "FIXED_ALL", "FIXED_BODYKEY" or "RCRESPOND" (loop enabled)
Default	"VARIABLE"
Function	<ul style="list-style-type: none"> • VARIABLE : "POWER/RECEPTION" key on TV unit or remote control is enabled. • FIXED_ALL : "POWER/RECEPTION" key on TV unit or remote control is disabled. • FIXED_BODYKEY : Only the "MAIN POWER" key on TV unit is disabled (The remote control is enabled). • RC RESPOND : The main unit's POWER switch toggles between ON and Standby (the same operation by the remote control).
Key disabled when set other than default	• OFF TIMER (SLEEP) (*Only when setting to FIXED_ALL)
Remarks	<ul style="list-style-type: none"> • When selecting to "FIXED_ALL", function related standby factors (see below) doesn't work. and not selecting OFF TIMER (Sleep) No operation OFF No signal OFF (including the power management) * These items does not exist according to the model.

If the power button is pressed in the ordinary mode in setting to "FIXED_ALL" and "FIXED_BODYKEY", the caution is displayed for 5 seconds.

When power button on the main unit is pressed

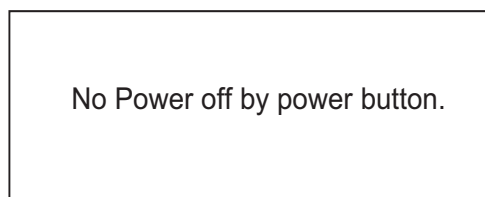

When power button on R/C is pressed

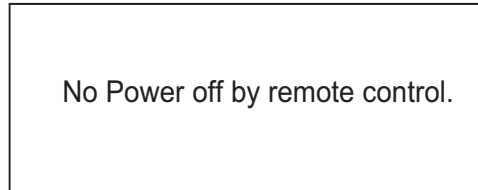

* The OSD display is an example.

If another ODS is previously displayed, the status is reset (MENU or similar).

2) Instantaneous current shutdown setting in turning off the power [SHUT DOWN MODE]

Option	"NORMAL" or "QUICK"
Default	NORMAL
Function	<ul style="list-style-type: none"> • This function decides whether scanning digital tuner is enabled or disabled when the power is standby. NORMAL : Scanning digital tuner is enabled when the power is standby. QUICK : Scanning digital tuner is disable <p>It is possible to put into the standby state instantaneously due to power off input, when the power is standby. Immediately, state is a complete standby.</p>
Remarks	<p>In selecting "QUICK", the function does not work for the following items (selection impossible.)</p> <ul style="list-style-type: none"> • ON TIMER, QUICK START, DIGITAL FIXED, etc. * These items does not exist according to the model.

3) Volume maximum level [MAXIMUM VOLUME]

Option	0~60 (loop disabled)
Default	60
Function	The volume cannot be increased more than the adjusted value (the main unit's speaker only).
Remarks	<ul style="list-style-type: none"> • When setting to 59 or less, only the figure is displayed in the normal mode; the volume bar is not displayed. • The volume of the headphones is limited. • The setting is impossible when VOLUME FIXED is set to FIXED.

10. Public Mode (continued)

4) Volume fixed [VOLUME FIXED]

Option	"VARIABLE", "FIXED", "ACCTRL" or "AC/RCCTRL" (loop enabled)
Default	"VARIABLE"
Function	<ul style="list-style-type: none"> • VARIABLE : The volume is not fixed. • FIXED : The volume is fixed to the value adjusted in the volume fixed level. • AC CTRL : The unit starts at the volume specified in the volume fixed level, when power is turned on in the case of the AC-ON only. • AC/RC CTRL : The unit starts at the volume specified in the volume fixed level, when power is turned on in any case. (AC→ON, remote control→ON, main unit's key→ON)
Exception	<ul style="list-style-type: none"> • In the adjustment process, the volume can be set to any level regardless of this setting.
Disabled key when setting to FIXED	<ul style="list-style-type: none"> • VOLUME UP/DOWN [both remote control and main unit] • MUTE * Main unit's key is enabled for operating menu.
Remarks	<ul style="list-style-type: none"> • [MAXIMUM VOLUME] has priority to [VOLUME FIXED] * When setting to FIXED, Maximum volume is fixed. • The volume of the headphones is fixed. • When setting to "FIXED", the volume is not displayed in operating Disabled key. • In menu operation, the main unit's keys (Vol (+/-)) are enabled.

5) Volume fixed level [VOLUME FIXED LEVEL]

Option	0~60 (loop disabled)
Default	20
Function	The volume is fixed to the adjusted value (the main unit's speaker only).
Exception	<ul style="list-style-type: none"> • In the adjustment process, the volume can be set to any level regardless of this setting.
Remarks	<ul style="list-style-type: none"> • When [VOLUME FIXED] is set to "VARIABLE", the setting cannot be changed.

6) Remote control operation [RC BUTTON]

Option	"RESPOND", "NORESPOND" or "LIMITED" (loop enabled)
Default	"RESPOND"
Function	<p>The operation of the remote control's keys is set.</p> <ul style="list-style-type: none"> RESPOND : The remote control's keys in the normal state are enabled. NO RESPOND : The remote control's keys in the normal state are disabled. The POWER key (RECEPTION/STANDBY key) is also disabled. LIMITED : only a part of keys (CHANNEL, etc.) is enabled and other keys are disabled.
Exception	<ul style="list-style-type: none"> • All the keys are enabled regardless of this setting while entering the adjustment process mode, inspection mode or Public Mode setting screen.
Remarks	The enable keys when setting to "LIMITED" are depended on Model.

7) Main Unit Operation [PANEL BUTTON]

Option	"RESPOND" or "NO RESPOND" (loop enabled)
Default	"RESPOND"
Function	<ul style="list-style-type: none"> • RESPOND : The main unit's keys are enabled. • NO RESPOND : The main unit's keys are disabled excluding the POWER key (RECEPTION/STANDBY key).
Exception	<ul style="list-style-type: none"> • The start operation in the adjustment process mode, inspection mode are enabled regardless of this setting. • All the keys are enabled regardless of this setting while entering the adjustment process mode, inspection mode or Public Mode setting screen. • For the models with the MENU key on the main unit, menu operation is possible regardless of the setting during the initial setting when the power is turned on for the first time.

10. Public Mode (continued)

8) Menu operation [MENU BUTTON]

Option	"RESPOND" or "NO RESPOND" (loop enabled)
Default	"RESPOND"
Function	The MENU key on the main unit and remote control is decided whether it is enabled or disabled.
Exception	<ul style="list-style-type: none"> RESPOND : The manu key is enabled. NO RESPOND : The manu key is disabled. <p>: All the keys are enabled regardless of this setting while entering the process mode, inspection mode or Public Mode setting screen.</p>
Disabled key excluding Menu key when setting to not default	All the direct transition keys to menu display (AUTO PRESET, MANUAL MEMORY and others) * These keys does not exist according to the model.
Remarks	When setting to "NO RESPOND" <ul style="list-style-type: none"> For the models with the MENU key on the main unit, menu operation is possible regardless of the setting while the initial setting when the power is turned on for the first time.

9) AV position fixed [AV POSITION FIXED]

Option	"VARIABLE" or "FIXED" (loop enabled)
Default	"VARIABLE"
Function	<ul style="list-style-type: none"> VARIABLE : AV position is not fixed. FIXED : AV position is fixed. <p>: The image/sound adjustment items in the menu are fixed in the selected state. : When receiving "AV POSITION" of the remote control, only the actual state is displayed, and setting is not changed.</p>
Remarks	<ul style="list-style-type: none"> When receiving the sound select direct keys (AV POSITION key, OPC, DOLBY key, etc.), only the actual state is displayed; no setting is changed. * These keys does not exist according to the model. The settings for the Public mode are retained after the personal data is initialized, each item for the AV position and image/sound adjustment are not initialized.

10) OSD display [ON SCREEN DISPLAY]

Option	"YES", "NO" or "LIMITED" (loop enabled) "LIMITED" is looped only in case of need (destination).
Default	"YES"
Function	<ul style="list-style-type: none"> YES : OSD is displayed NO : the following OSD is not displayed. Registration, setting, adjustment menu, channel call, volume bar, and input select LIMITED : only a part of OSD (CH call: "New Information" etc...) is not displayed.
Key which may be enabled (Example of the confusing key)	<ul style="list-style-type: none"> It is OK in the case that simple input select occur or the original state returns soon automatically.
Disabled key when setting to not default	<ul style="list-style-type: none"> When setting to "NO", the keys which is related to visibility of the screen and sound cannot be used. STILL IMAGE, SCREEN DISPLAY, OFF TIMER, AV POSITION, BRIGHTNESS SENSOR, SCREEN SIZE SELECT, AUTO PRESET, MANUAL MEMORY, IMAGE SELECT, SOUND SELECT, LANGUAGE, Closed caution * Disabled keys dependeds on the models.
Remarks	<ul style="list-style-type: none"> When setting to "NO", ON TIMER (Watching reservation) is cleared. OFF TIMER "SLEEP" is cleared. * These items does not exist according to the model. When setting to "NO", These Displays (Version-up, Public mode setting screen, Pass Word input screen of Public Mode, the adjustment process mode, K mark of inspection mode) are enabled regardless of this setting.

10. Public Mode (continued)

11)Start mode [INPUT MODE START]

Option	“NORMAL” or “Input source 1 (input selection or channel)” ... (loop enabled)
Default	“NORMAL”
Function	which kinds of input source or channel is decided when the power turning on. NORMAL : the content of the last memory is followed.
Remarks	<ul style="list-style-type: none"> When setting to not Normal, ON TIMER (Watching reservation) has priority. When setting to “NORMAL”, [INPUT MODE FIXED] is set to “VARIABLE” and [INPUT MODE FIXED] is prohibited to select. (selection impossible.)

Example of option: “NORMAL”, “TVD (002TV)”, “INPUT1”, “INPUT2”, “INPUT3”, “HDMI1”, “HDMI2”, “HDMI3”, “HDMI4”.

12)Input fixed [INPUT MODE FIXED]

Option	“VARIABLE”, “FIXED”, “ACCTRL” or “AC/RCCTRL” (loop enabled)
Default	VARIABLE
Function	<p>VARIABLE : If [INPUT MODE START] is set to Normal, input mode is not fixed.</p> <p>FIXED : when “INPUT MODESTART” is active, it is impossible to switch to another channel or input source.</p> <p>AC CTRL : when “INPUT MODESTART” is active the unit starts at the input mode which is selected when power is turned on in the case of the AC-ON only.</p> <p>AC/RC CTRL : when “INPUT MODESTART” is active the unit starts at the input mode which is selected when power is turned on in any case (AC→ON, remote control→ON, main utit's key→ON)</p>
Disabled key when setting to “FIXED”	CHANNEL (+/-), DIRECT CHANNEL buttons, FLASHBACK, INPUT SELECT, TV/VIDEO, AUTO PRESET, MANUAL MEMORY, i.LINK, DIRECTINPUTSELECT, ATV, DTV, EPG, RADIO etc...
Remarks	<ul style="list-style-type: none"> If [INPUT MODE START] is Normal, this function cannot be set. Set to “VARIABLE” automatically. When setting to “FIXED”, The item related to the channel setting and input selection in Menu are not displayed. ON TIMER (Watching reservation) is not active. * These items does not exist according to the model.

13)Speaker ON/OFF selection [LOUD SPEAKER]

Option	“ON” or “OFF” (loop enabled)
Default	ON
Function	<p>ON : The sound from the speakers is output.</p> <p>OFF : The sound from the speakers is not output even if the headphones are not used.</p>
Remarks	<ul style="list-style-type: none"> When the VOL (+/-) key is pressed, the mute icon is displayed for 4 seconds. For the MUTE key and sound-related keys, caution is displayed. For the headphones, normal operation is possible.

14)Remote control path through [RC PATH THROUGH]

Option	“OFF”, “ON: TVRCE” or “ON: TVRCD” (loop enabled)
Default	OFF
Function	<p>The item decide whether the signal received by the remote control’s light-receiving section is output to the blankpin (9pin) of RS232C.</p> <p>OFF : this function is not active.</p> <p>ON: TVRCE : this function is active, and remote control is active, too</p> <p>ON: TVRCD : this function is active, but remote control is not active</p>
Exception	<ul style="list-style-type: none"> In the case of “ON: TV RCD”, the start operation in the adjustment process mode, inspection mod are enabled regardless of this setting. In the case of “ON: TV RCD”, all the keys are enabled regardless of this setting while entering the adjustment process mode, inspection mode or Public mode setting screen.
Remarks	* Remote control path through does not exist according to the model.

10. Public Mode (continued)

15)232C power ON control [232C POWON]

Option	"ENABLE" or "DISABLE" (loop enabled)
Default	DISABLE
Function	The item decide whether Power ON by the 232C command is enabled/disabled in the standby state. The same function as 232C command "RSPW". ENABLE : POWR0001 is always enabled. DISABLE : Start-up may be impossible at POWR0001. (If the 232C command reception module is set to OFF, the command is invalid.)

16)Public mode setting [PUBLIC MODE]

Option	"OFF" or "ON" (loop enabled)
Default	OFF
Function	The item decide whether Public mode setting menu are enabled or disabled. The same item as [PUBLIC MODE] in the adjustment process menu. OFF : Public mode is not active ON : Public mode is active
Remarks	Each operation of the Public mode is impossible unless this item is set to ON.

11. Copy Mode

1. Starting the Copy Mode

- There are two following ways to display the Copy Mode setting screen.

1) Method of needing password

- Turn off the power, refer to "3. Method of shuts down for Power supply"
- While holding down the "INPUT" and "Volume (+)" keys on the set at once, touch the power supply key on the set.
Please separate the finger from the power supply key when boot-up is confirmed with lighting of a central icon etc.
After a while, value of Enter password appears on the screen.
- Display the Pass Word input screen.

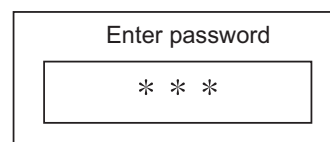
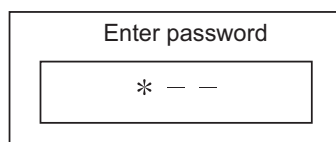
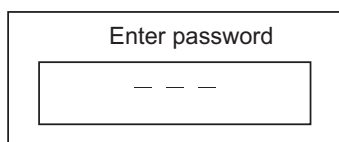

Operation procedure

- The initial input position is the digit at the left end.
- For the numeric keys "0" to "9" of R/C, key input is accepted.
Input of the other keys is prohibited
- Change "—" to "*" by inputting the numeric key at the input position, and shift the input position rightward one digit.
- When three digits are completely input, the Pass Word is judged.

d) Check the Pass Word by inputting three digits.

If the Pass Word "3" "6" "9", it shifts to the Copy Mode setting screen.
In another case, the screen is erased, and it operates in the ordinary mode.

2. Exiting the Copy Mode Setting screen

There is following way to exit the Copy Mode setting screen.

- Turn off the power (Unplug the AC power cord from the outlet to forcibly turn off the power.)

3. Basic operation in the Copy Mode

CH (+/-) or Cursor (▲ / ▼)	Movement to the selected item.
Decision (ok)	Execution

11. Copy Mode (continued)

4. Restriction of Copy Mode

- USB thumb drive should be more than 1Mbyte.
- File system of USB thumb drive should be FAT (FAT32)
- More than one USB thumb drive shouldn't be connected to TV.
- All USB terminals can be valid, but more than one USB thumb drive shouldn't be connected to TV.
- If USB device is detected by TV, focus is not appropriated to items.
- In Copy mode (TV→USB) and (USB→TV), following should be munched.

Vender Name (Fixed)

Key Information (Fixed)

USB Cline Version

Inch Size

Country setting (Factory initialization)

Model Name

Software Version

- In each TV, setup of Network and IP control should be set again.

NOTE: Copy Mode can start right there when the TV is powered on.

It is unnecessary to execute "Initial Auto Instration"

(Obviously, setting the country is also unnecessary.)

"Initial Auto Instration" can be interrupted by pressing ↵ (Return key) on remote controller

5. Copy data

Copy data is as follows;

Copy Data	Remarks
Size of Ch call	
Card slot selection Setting	
Alphabet sorts do/not	
HOME/Store Setting	
Public Setting	
Sound multiplex information in each Ch	
Administrative information for Time Shift	Vendor ID, Product ID, Serial ID for storage
Communication's information	IP address, Gateway, DNS address Kinds of Security key encryption (WiFi) Access point identifier (WiFi) Key for access point
IP control setting information	Device name, Login ID, Password, Communication port
DTV service list	Number of all services CH list Number of broadcasting on each network
Last value	Last network information (DVB-T, DVB-S, DVB-C, ATV) Last channel information Volume, wide mode, and subtitle
Local Time Information	Information that corrects ±X time against Universal Time
User Manu Data	User Menu Data don't have these information. Temporary data Message list, Reception report, EPG, Off timer, Off video, and Signal strength Peculiarity data for TV DRM information for DivX, Mac address, and Accumulated time information Connected equipment information (But the recorder selection of the AQUOS LINK setting can be copied.) physical address Category of equipment Maker Name Connected model name Data related to encrypted broadcasting (CI+) Adjustment process mode Data

11. Copy Mode (continued)

6. Operating

1) Copy mode(TV→USB))

- ① Execute start in Copy Mode setting screen.

※ If USB device is detected by TV,
focus is not appropriated to items.

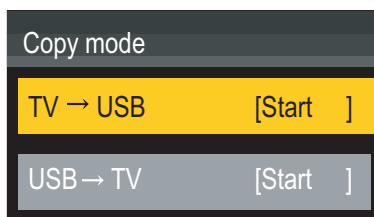

Execute

- ② [Wait···] is displayed while executing it.
When succeeding: Done is displayed
When failing: Failed is displayed.

※ Key opration is not valid in coping.

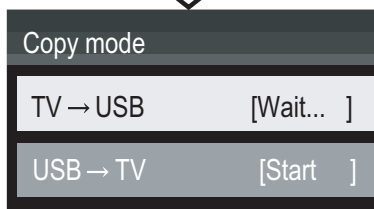

Success

Fail

- ③ After success of copy,
unplug the AC power cord from the outlet,please.

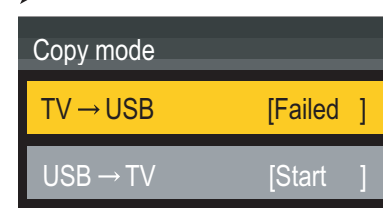
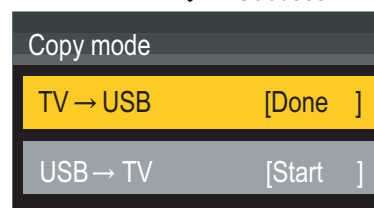

2) Copy mode(USB→TV))

- ① Execute start in Copy Mode setting screen.

※ If USB device is detected by TV,
focus is not appropriated to items.

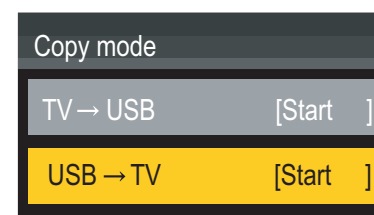

Execute

- ② [Wait···] is displayed while executing it.
When succeeding: Done is displayed
When failing: Failed is displayed.

※ Key opration is not valid in coping.

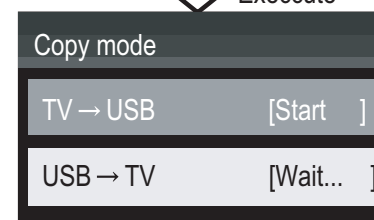

Success

Fail

- ③ After success of copy,
unplug the AC power cord from the outlet,please.

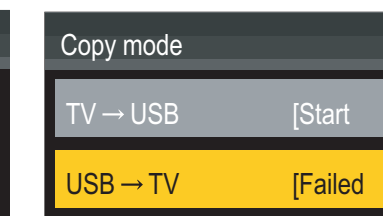
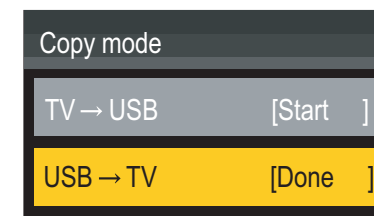

12. Video Signal Adjustment Procedure

The adjustment process mode menu is listed in Section 5.

Signal generator level adjustment check (Adjustment to the specified level)

- Composite signal PAL : 0.7Vp-p ± 0.02Vp-p (Pedestal to white level)
- 33K component signal (50 Hz) : Y level : 0.7Vp-p ± 0.02Vp-p (Pedestal to white level)
: PB, PR level : 0.7Vp-p ± 0.02Vp-p
- ANALOG PC(RGB) signal : RGB level : 0.7Vp-p ± 0.02Vp-p

12.1. Entering the adjustment process mode

Enter the adjustment process mode according to Section 4.

12.2. PAL signal adjustment

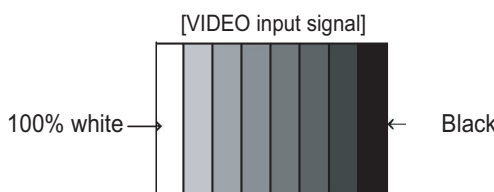
	Adjustment point	Adjustment conditions	Adjustment procedure
1	Setting	[Signal] PAL Full field colour bar composite signal [Terminal] EXT1 SCART Video (PAL) IN	<ul style="list-style-type: none"> • Feed the PAL full field colour bar signal (75% colour saturation) to EXT1 SCART IN. 
2	Auto adjustment performance	Adjustment process [PAL ADJ] page 4/23	Bring the cursor on [PAL ADJ] and press [OK]. [PAL ADJ OK] appears when finished.

* **ATTENTION:** Regarding adjustment of SECAM, add OFFSET value to the value of D_GAIN/OFFSET in PAL signal adjustment, please.
(A_GAIN should be fixed.)

	OFFSET Value
D-GAIN	-26
D-OFFSET	1

12.3. TUNER adjustment

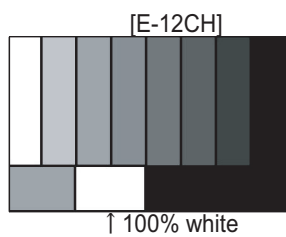
	Adjustment point	Adjustment conditions	Adjustment procedure
1	Setting	[Signal] PAL split field colour Bar RF signal UV [Terminal] TUNER	<ul style="list-style-type: none"> • Feed the PAL Split Field colour bar signal (E-12ch) to TUNER. • Make sure the PAL colour bar pattern has the sync level of 7:3 with the picture level. Signal level: 55 dB μ V ± 1dB (75 Ω LOAD) 
2	Auto adjustment performance	Adjustment process [TUNER ADJ] page 3/23	Bring the cursor on [TUNER ADJ] and press [OK]. [TUNER ADJ OK] appears when finished.

12. Video Signal Adjustment Procedure (continued)

12.4. ADC adjustment (Component 33K)

	Adjustment point	Adjustment conditions	Adjustment procedure
1	Setting	[Signal] COMP33K, 50Hz 100% Full field colour bar Signal [Terminal] EXT3 COMPONENT IN	<ul style="list-style-type: none"> Feed the COMPONENT 33K 100% full field colour bar signal (100% colour saturation) to EXT3 COMPONENT IN. 
2	Auto adjustment performance	Adjustment process [HDTV ADJ] page 7/23	Bring the cursor on [HDTV ADJ] and press [OK]. [HDTV ADJ OK] appears when finished.

* **ATTENTION:** Regarding ADC adjustment (Component 15K), add OFFSET value to the value of Component 33K, please.

	OFFSET Value
Y-GAIN	2
Cb-GAIN	8
Cr-GAIN	7
Y-OFFSET	4
Cb-OFFSET	2
Cr-OFFSET	1

12.5. PC signal adjustment (ANALOG D-Sub 15pin)

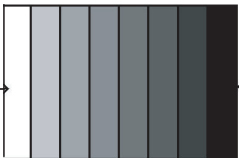
	Adjustment point	Adjustment conditions	Adjustment procedure
1	Setting	[Signal] XGA, 60Hz 100% Full Field Colour Bar Signal [Terminal] PC IN	<ul style="list-style-type: none"> Feed the XGA 60Hz 100% full field colour bar signal (100% colour saturation) to PC IN. 
2	Auto adjustment performance	Adjustment process [ANALOG PC ADJ] menu page 8/23	Bring the cursor on [ANALOG PC ADJ] and press [OK]. [ANALOG PC ADJ OK] appears when finished.

* **ATTENTION:** Regarding SCART adjustment, add OFFSET value to the value of PC signal adjustment, please.

	OFFSET Value
R-CUTOFF	3
G-CUTOFF	3
B-CUTOFF	8
R-GSIN	10
G-GAIN	8
B-GAIN	11

13. White Balance Adjustment

For white balance adjustment, adjust the offset values on pages 11/23.

[Condition of the unit for inspection] : Modulated light (+16)

AV MODE: DYNAMIC

Active Backlight: OFF

OPC: OFF

Asing Time: Min, 60 minute

[Input signal condition] : HDMI 1080i 15IRE (LO), 78IRE (HI)

[Adjustment reference device] : Minolta CA-210

[Adjustment procedure]

1) Display the current adjustment status at R/G/B_GAIN (HI). (Page 11/23 of process adjustment)

The signal of 78IRE is input.

2) Read the value of the luminance meter. $x=0.272$, $y=0.277$

3) Change R_GAIN (HI)/ B_GAIN (HI) (Adjustment offset value) on page 11/23 of process adjustment so that the values of the luminance meter approach $x=0.272$ and $y=0.277$.

(Basically, G is not changed. If adjustment fails with R and B, change G. When G is lowered, the weaker of R or B must be fixed.)

4) Display the adjustment status of the current R/G/B_GAIN (LO).

The signal of 15IRE is input.

Change R_GAIN (LO)/ B_GAIN (LO) (adjustment offset value) on page 11/23 of process adjustment so that the values of the luminance meter approach $x=0.272$ and $y=0.277$.

5) Both HI and LO are repeating the step from 1 to 4 until becoming an aim value.

[Adjustment reference standard value]

Adjustment spec ± 0.002 Inspection spec ± 0.004 (point LO)

Adjustment spec ± 0.001 Inspection spec ± 0.002 (point HI)

6) After completing adjustments, set EEP SAVE (Page 23/23) to ON in the process menu to save the white balance adjustment value.

14. Confirmation Item

1. HDMI-CEC Inspection

After repairing the CEC function, check the operation about HDMI-CEC circuit.

2. CI card Inspection

After repairing the CI function, check that the DTV signal is received by inserting CAM.

And check the KEY certification by inserting CAM which is prepare for CI+.

3. LAN Inspection (NET)/test connectivity of SD card.

After repairing the LAN function, check the communication by connecting PC and LAN terminal.

And test connectivity of SD card.

4. 3D Check

5. IR communication Check / IR Emitter (Infrared light Output) Inspection.

15. Initialization to factory settings

CAUTION: When the factory settings have been made, all user setting data, including the channel settings, are initialized.
(The adjustments done in the adjustment process mode are not initialized.) Keep this in mind when initializing these settings.

	Adjustment item	Adjustment conditions	Adjustment procedure
1	Factory settings	Ends by turning off the MAIN POWER key. (See to below caution)	<p>[Factory setting with adjustment process mode]</p> <ul style="list-style-type: none"> • Enter the adjustment process mode. • Move the cursor to [INDUSTRY INIT] on page 2/23. • Use the R/C key to select a region from [EUROPE/RUSSIA/ SWEDEN] and press the [OK] key. • "EXECUTING" display appears. • After a while, "SUCCESS" display appears, the setting is completed. <p>When succeeding: Background color (green) When failing: Background color (red)</p> <p>The following items are initialized in the factory setting.</p> <ol style="list-style-type: none"> 1) User settings 2) Channel data (e.g. broadcast frequencies) 3) Maker option setting 4) Password data

After adjustments, exit the adjustment process mode.
To exit the adjustment process mode, unplug the AC power cord from the outlet to forcibly turn off the power.
When the power is turned off with the remote control, unplug the AC power cord and plug it back in (wait approximately 20 seconds before plugging in the AC power cord)
After completing the NET connection., execute the NET initialization (Record of the server access)

Please execute the initialized in the factory setting again when you turn on the power supply after the initialized in the factory setting is set.

SOFTWARE UPDATING

Software Updating

1. Turn on the AC power.
2. Insert the upgrading USB flash memory for upgrade into the service slot.
(After a while, an external input changes into USB automatically.)
3. Use the Menu button and cursor keys (◀/▶/▲/▼), Ch keys (∨/∧) of R/C or on the set to select Menu - Setup - Information - Software update - USB update on OSD menu.
4. The message (Insert the USB memory device contains the software update file) shows up.
Push OK when if there is no problem.

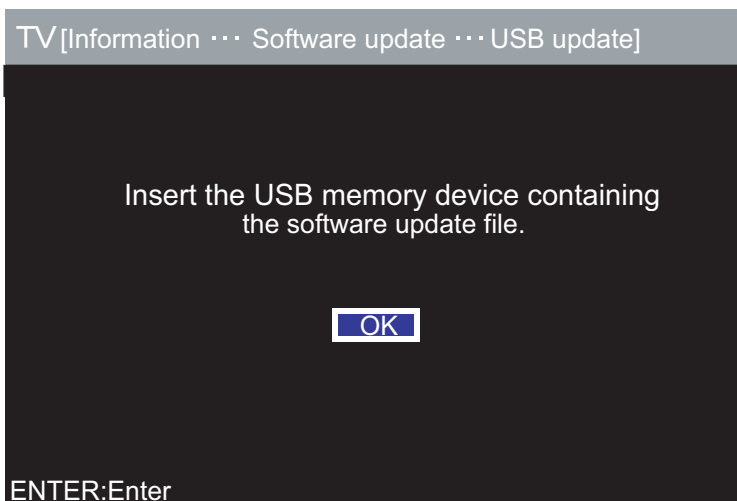

5. After a while, if software update file is detected in the USB memory device, the following screen shows up.
Select OK when if there is no problem.

NOTE: If USB memory device isn't correctly inserted in TV, caution shows up.

Please insert USB memory device and retry software update.

NOTE: If there are more than two software update files in the USB memory device, caution shows up.

Please insert one file and retry software update.

NOTE: If there is no software update file in the USB memory device, caution shows up.

Please insert the correct file and retry software update.

NOTE: If software update file in the USB memory device doesn't match this model, caution shows up.

(Because Model name is unmatched or check sum error occurs)

Please insert the correct file and retry software update.

NOTE: If software update file in the USB memory device is already installed, caution shows up.

Please reconfirm the software version and reinstall (if necessary)

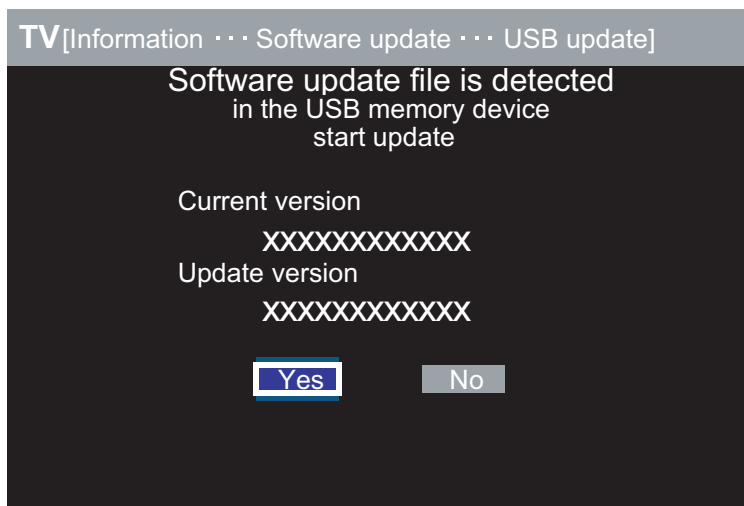

Software Updating (Continued)

6. The caution for update shows up.
- The picture will temporary go dark until the software update display apees
 - Wait several minutes and don't unplug the AC cord
- Select OK when if there is no problem.

7. Software update starts.

Please wait for a while until the bar shows 100%

NOTE: Do not take out the USB memory device during updating.

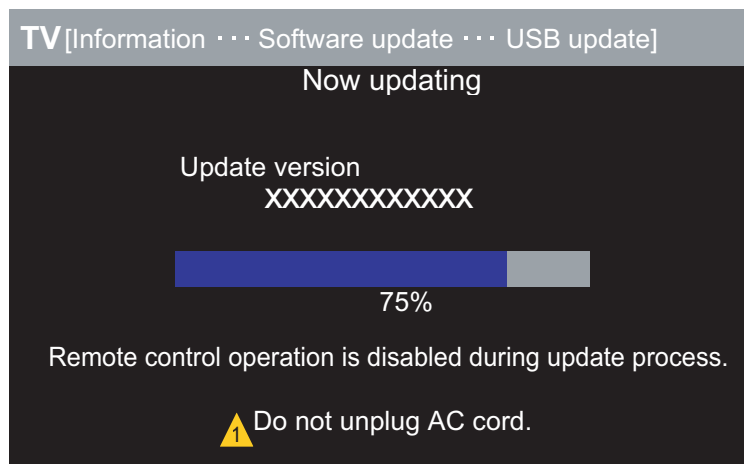

8. When all the procedures are complete, the following upgrade success screen shows up.

The new software version can be confirmed on screen.

After a while, Turn off power and boot-up automaticaly.

NOTE: TV is restarted automaticaly, the AC code need not be pulled out.

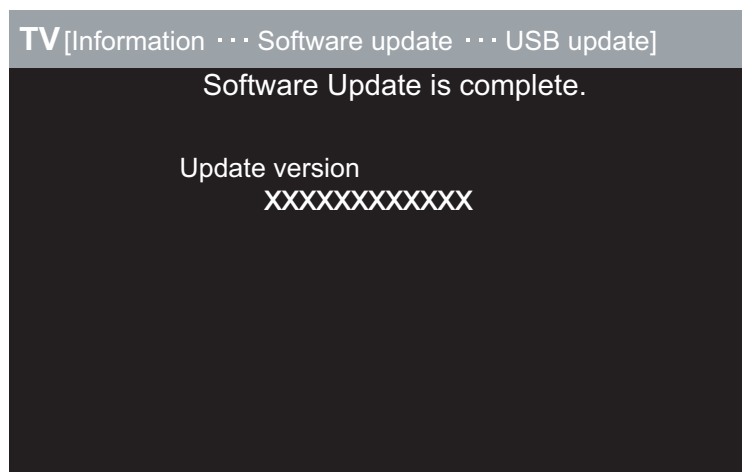

9. After boot-up, the following caution shows up.

Select OK when if there is no problem.

Software update is completed, please remove the USB memory device.

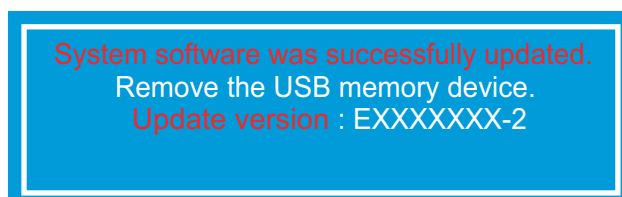

NOTE: Then get the set started and call the process adjustment screen (Top Page) to check the main software version.

TROUBLESHOOTING TABLE

No power (Central Icon LED failure to light up) or No startup (Central Icon LED is flashing)

↓			
↓	Is the AC cord connector tightly connected to the set?	NO	Reconnect the AC cord tightly and turn on the power again.
↓ YES			
↓	Are the wire harnesses and other cables properly connected to the set?	NO	Reconnect the wire harnesses and other cables properly to the set.
↓ YES			
↓	Is power supplied from pins [9/BU+5V] of [PD] P9602?	NO	Replace the power unit.
↓ YES			
↓	Is there the pins [12/PS_ON] of [PD] P9602 at "H"?	NO	Check the signal line between PS_ON and IC2001 (UCOM)/IC3303 (Digital AV decode & Main CPU).
↓ YES			
↓	Is there the pins [11/AC_DET] of [PD] P9602 at "H"?	NO	Check the power unit, and the signal line between AC_DET and IC2001/IC3303.
↓ YES			
↓	Is power supplied from pins [17~20/UR+13V] of [PD] P9602 as specified?	NO	Check the line between PS_ON and IC2001/IC3303.
↓ YES			
↓	Are the DC/DC converter outputs and the output voltages along the control lines as specified?	NO	Check the DC/DC converters and the control lines. Replace defective parts as required.
	1) BU3.3V (IC9609 etc.) 2) D5.6V (IC9608 etc.) 3) D5V (IC9603 etc.) 4) U5V (IC9602 etc.) 5) D3.3V (IC9605 etc.) 6) M1.8V (IC9607 etc.) 7) D1.5V (IC9604 etc.) 8) D1.2V (IC1509 etc.) 9) D1.1V (IC9606 etc.) 10)AT5V (IC1104 etc.) 11)IF1.8V (IC1109 etc.) 12)SAT+1.2V (IC1102 etc.) 13)STB+3.3V (Q9607 etc.) 14)SD3.3V (IC8456 etc.) 15)CPU_A+1.2V (IC3301 etc.) 16)CIIN+5V (IC4403 etc.) 17)MT5135+1.1V (IC4401 etc.)		

Troubleshooting Table (continued)

The sound is not emitted from the Speaker & Woofer though the picture has come out.		
↓		
No sound output in all modes?		
↓ YES		
Do audio signals output from pins [Y30/CPU_AOLRCK, Y31/CPU_AOBCK, V27/CPU_AOSDATA0] of IC3303 (Digital AV decode & Main CPU)?	NO →	Check IC3303 and its peripheral circuits.
↓ YES		
Do audio signals input to pins [7, 8, 9] of IC2701 (DSP)?	NO →	Check the line between IC3303 and IC2701.
↓ YES		
Do audio signals output from pins [43/AMP_BCLK, 44/AMP_LRCLK, 45/AMP_DATA_LR, 46/AMP_DATA_SW, 47/AMP_MCLK] of IC2701?	NO →	Check IC2701 and its peripheral circuits.
↓ YES		
In the case that the sound is not emitted from the Speaker, refer to (A). In the case that the sound is not emitted from the Woofer, refer to (B).		
↓ (A)		
Do audio signals input to pins [5, 6, 7, 8] of IC2703 (SP_AMP)?	NO →	Check the line between IC2701 and IC2703.
↓ YES		
Do audio signals output from pins [28/OUTML, 30/OUTPL, 12/OUTPR, 14/OUTMR] of IC2703?	NO →	Check IC2703 and its peripheral circuits.
↓ YES		
Is AMP_MUTE [pin (21)] of IC2703 at "H"?	NO →	Check the line between IC2703 and IC3303 & IC2001 (UCOM). (Q2701,D2701 etc...)
↓ YES		
Do audio signals input to pins [1&2/L-ch, 3&4/R-ch] of P2701?	NO →	P2701 terminal and the peripheral circuit (L/C filter) are checked.
↓ YES		
Check Speaker (right and left) and wire harness.		
↓ (B)		
Do audio signals input to pins [5, 6, 7, 8] of IC2702 (Woofer_AMP)?	NO →	Check the line between IC2701 and IC2702.
↓ YES		
Do audio signals output from pins [28/OUTML, 30/OUTPL, 12/OUTPR, 14/OUTMR] of IC2702?	NO →	Check IC2702 and its peripheral circuits.
↓ YES		
Is AMP_MUTE [pin (21)] of IC2702 at "H"?	NO →	Check the line between IC2702 and IC3303 & IC2001. (Q2701,D2701 etc...)
↓ YES		
Do audio signals input to pins [1/SUB (+), 2/SUB (-)] of P2702?	NO →	P2702 terminal and the peripheral circuit (L/C filter) are checked.
↓ YES		
Check Woofer and wire harness.		

Troubleshooting Table (continued)

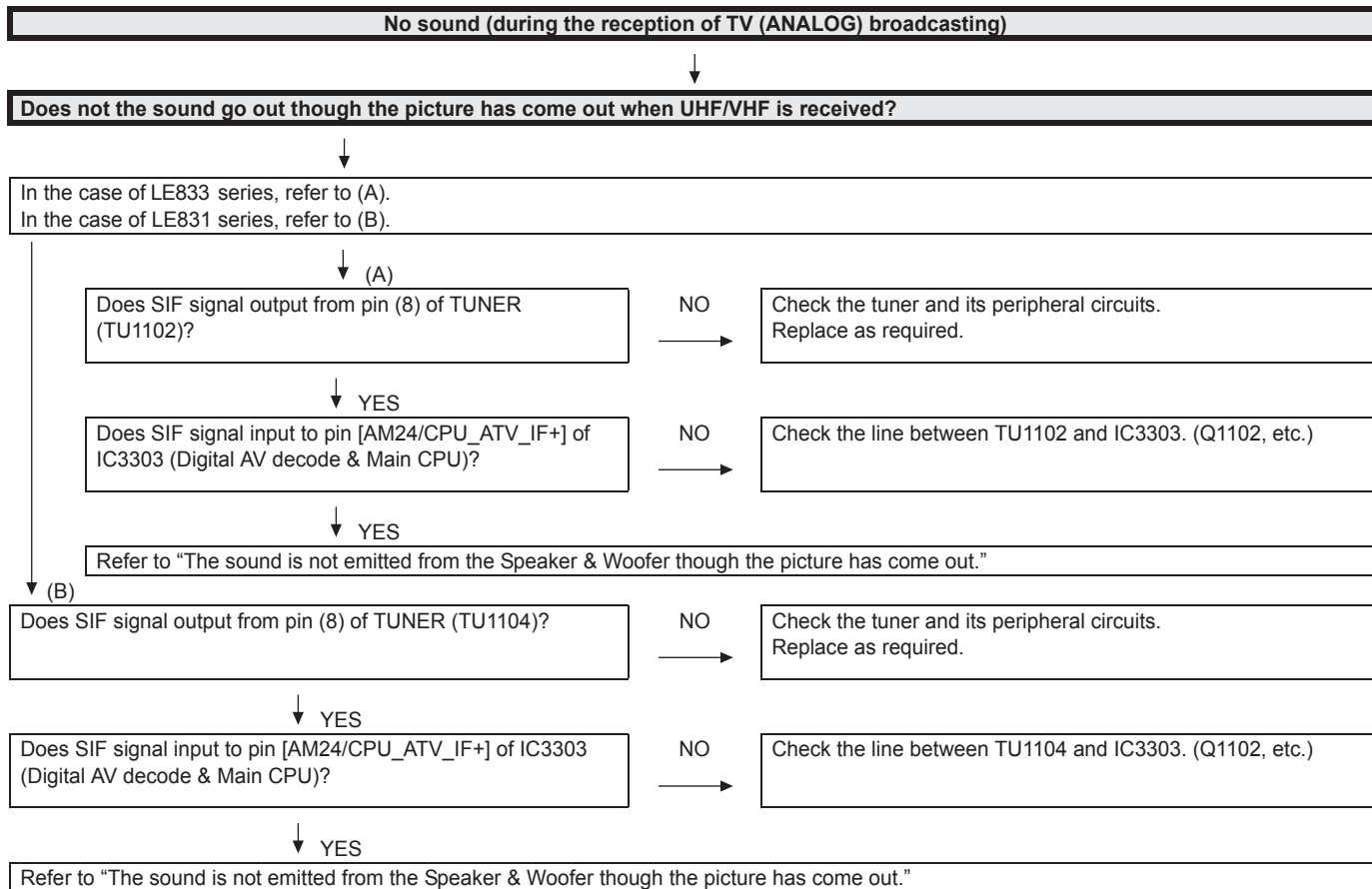

Troubleshooting Table (continued)

No sound (during the reception of TV (DIGITAL) broadcasting)

Does not the sound go out though the picture has come out when DTV is received?

In the case of LE833 series, refer to (A).
In the case of LE831 series, refer to (B).

↓ (A)

Do IF signals output to pins [10, 11] of TUNER (TU1102)?

NO

Check the tuner and its peripheral circuits.
Replace as required.

↓ YES

Do IF signals input to pins [35/IFPGA_INN, 36/IFPGA_INP] of IC4402 (CI Cont & DTB-T/C Demod)?

NO

Check the line between IC1102 and IC4402.

↓ YES

Do TS signals output to pins [15/DEMOD_TS_DATA0, 16/DEMOD_TS_SYNC, 17/DEMOD_TS_VAL, 18/DEMOD_TS_CLK] of IC4402?

NO

Check IC4402 and its peripheral circuits.

↓ YES

Do TS signals input to pins [U30/DEMOD_TSDATA0, V30/DEMOD_TSSYNC, V29/DEMOD_TSVAL, U32/DEMOD_TSCLK] of IC3303 (Digital AV decode & Main CPU)?

NO

Check the line between IC4402 and IC3303.

↓ YES

Refer to "The sound is not emitted from the Speaker & Woofer though the picture has come out."

↓ (B)

Do TS signals output to pins [19/TS_TUOUT_CLK, 17/TS_TUOUT_SYNC, 18/TS_TUOUT_VAL, 20~27/TS_TUOUT_D0~7] of TUNER (TU1104)?

NO

Check the tuner and its peripheral circuits.
Replace as required.

↓ YES

Do TS signals input to pins [45/TS_TUOUT_CLK, 46/TS_TUOUT_SYNC, 47/TS_TUOUT_VAL, 48, 51~57/TS_TUOUT_D0~7] of IC4402 (CI Cont & DTB-T/C Demod)?

NO

Check the line between TU1104 and IC4402.

↓ YES

Do TS signals output to pins [15/DEMOD_TS_DATA0, 16/DEMOD_TS_SYNC, 17/DEMOD_TS_VAL, 18/DEMOD_TS_CLK] of IC4402?

NO

Check IC4402 and its peripheral circuits.

↓ YES

Do TS signals input to pins [U30/DEMOD_TSDATA0, V30/DEMOD_TSSYNC, V29/DEMOD_TSVAL, U32/DEMOD_TSCLK] of IC3303 (Digital AV decode & Main CPU)?

NO

Check the line between IC4402 and IC3303.

↓ YES

Refer to "The sound is not emitted from the Speaker & Woofer though the picture has come out."

Troubleshooting Table (continued)

No sound (during the reception of TV (DIGITAL-Satellite) broadcasting)



Does not the sound go out though the picture has come out when DTV is received?



Do TS signals output to pins [44/TS_TUOUT_CLK, 46/TS_TUOUT_SYNC, 45/TS_TUOUT_VAL, 43~36/TS_TUOUT_D0~7] of TUNER(TU1102)?

NO
→

Check the tuner and its peripheral circuits.
Replace as required.



YES

Do TS signals input to pins [45/S2_TS_CLK, 46/S2_TS_SYNC, 47/S2_TS_VAL, 48,51~57/S2_TS_DATA0~7] of IC4402 (CI Cont & DTB-T/C Demod)?

NO
→

Check the line between TU1102 and IC4402.



YES

Do TS signals output to pins [15/DEMOD_TS_DATA0, 16/DEMOD_TS_SYNC, 17/DEMOD_TS_VAL, 18/DEMOD_TS_CLK] of IC4402?

NO
→

Check IC4402 and its peripheral circuits.



YES

Do TS signals input to pins [U30/DEMOD_TSDATA0, V30/DEMOD_TSSYNC, V29/DEMOD_TSVAL, U32/DEMOD_TSCLK] of IC3303 (Digital AV decode & Main CPU)?

NO
→

Check the line between IC4402 and IC3303.



YES

Refer to "The sound is not emitted from the Speaker & Woofer though the picture has come out."

No sound from external input devices (1)



Does not the sound of the audio signal input to EXT1 go out?



Do audio signals input to pins [2/AUDIO_IN_R, 6/AUDIO_IN_L] of EXT1 (SC505)?

NO
→

Check the setting of an external input device that connects with EXT1.



YES

Do audio signals input to pins [AM32/SC1_AINR0, AM30/SC1_AINL0] of IC3303 (Digital AV decode & Main CPU) from SC505?

NO
→

Check the line between SC505 and IC3303.



YES

Refer to "The sound is not emitted from the Speaker & Woofer though the picture has come out."

Troubleshooting Table (continued)

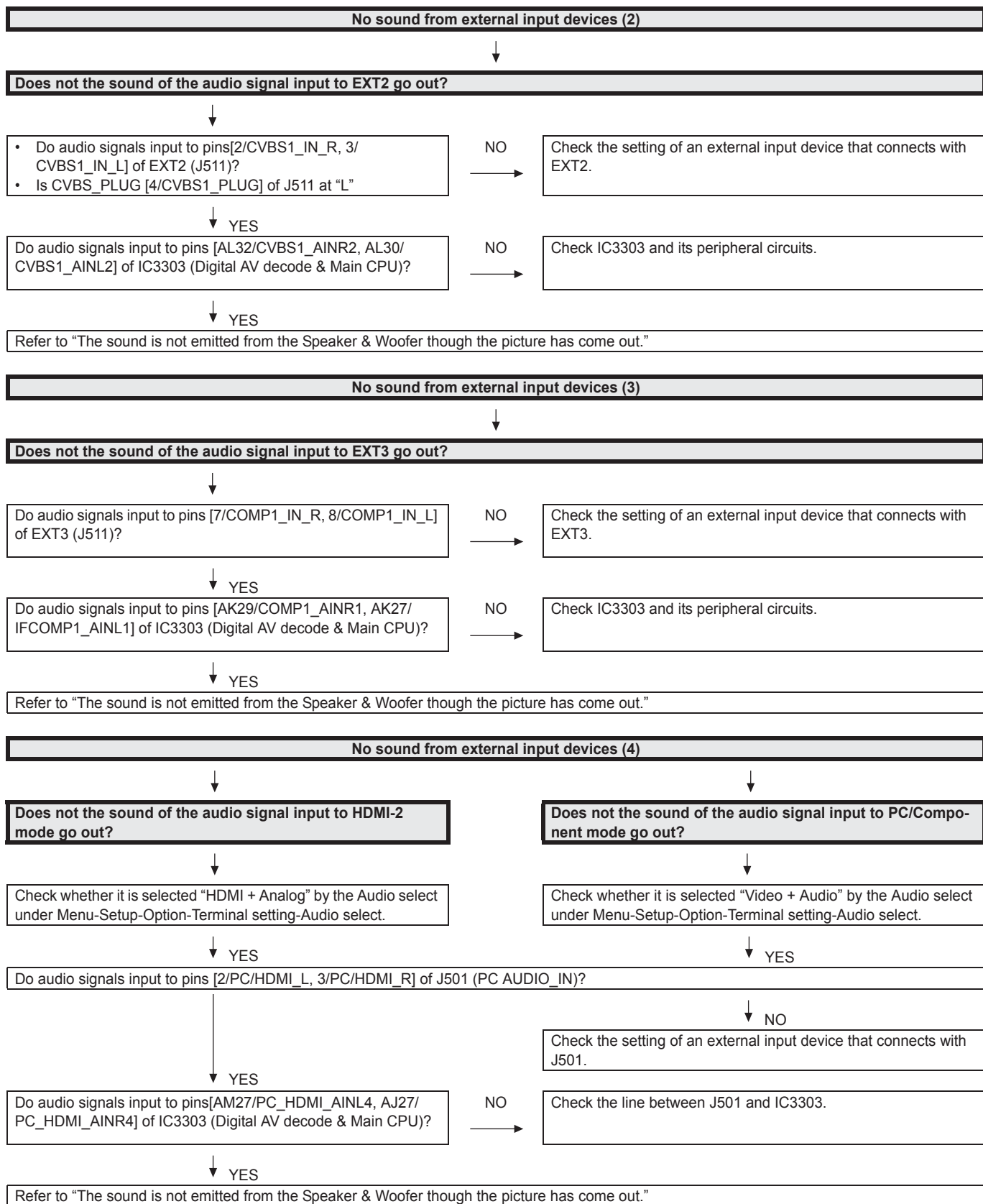

Troubleshooting Table (continued)

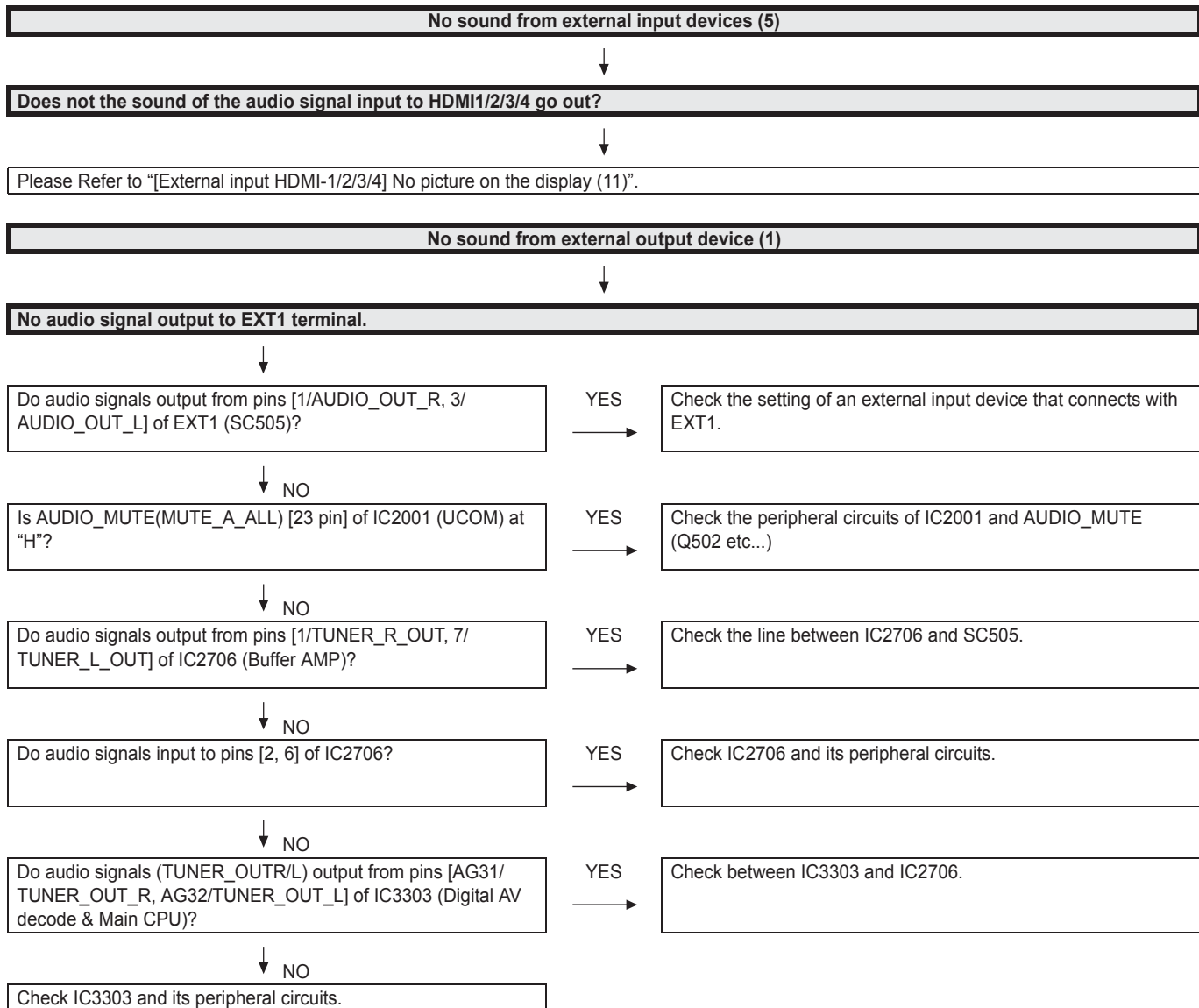

Troubleshooting Table (continued)

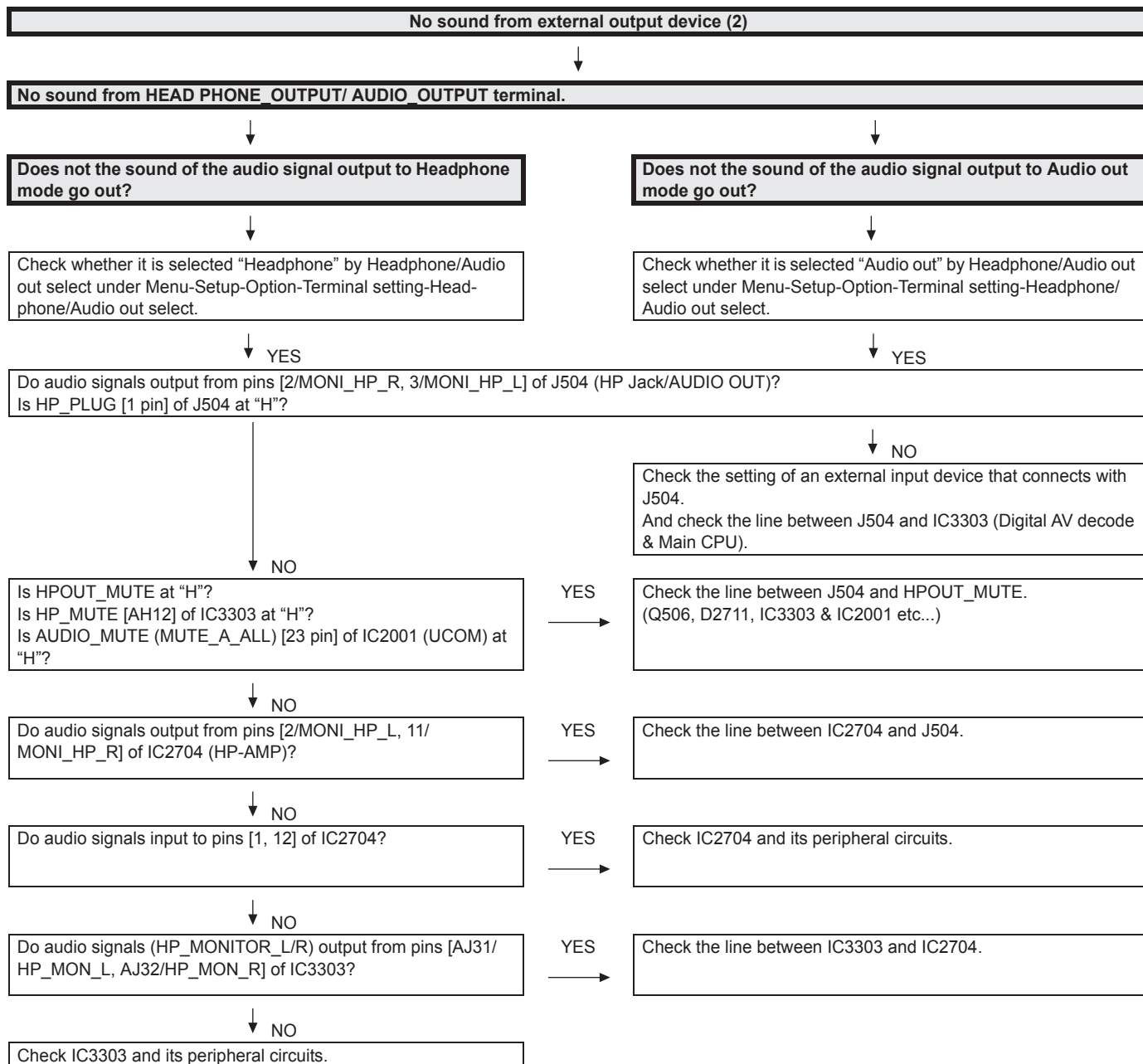

Troubleshooting Table (continued)

No sound from external output device (3)

No sound from DIGITAL AUDIO OUTPUT terminal.

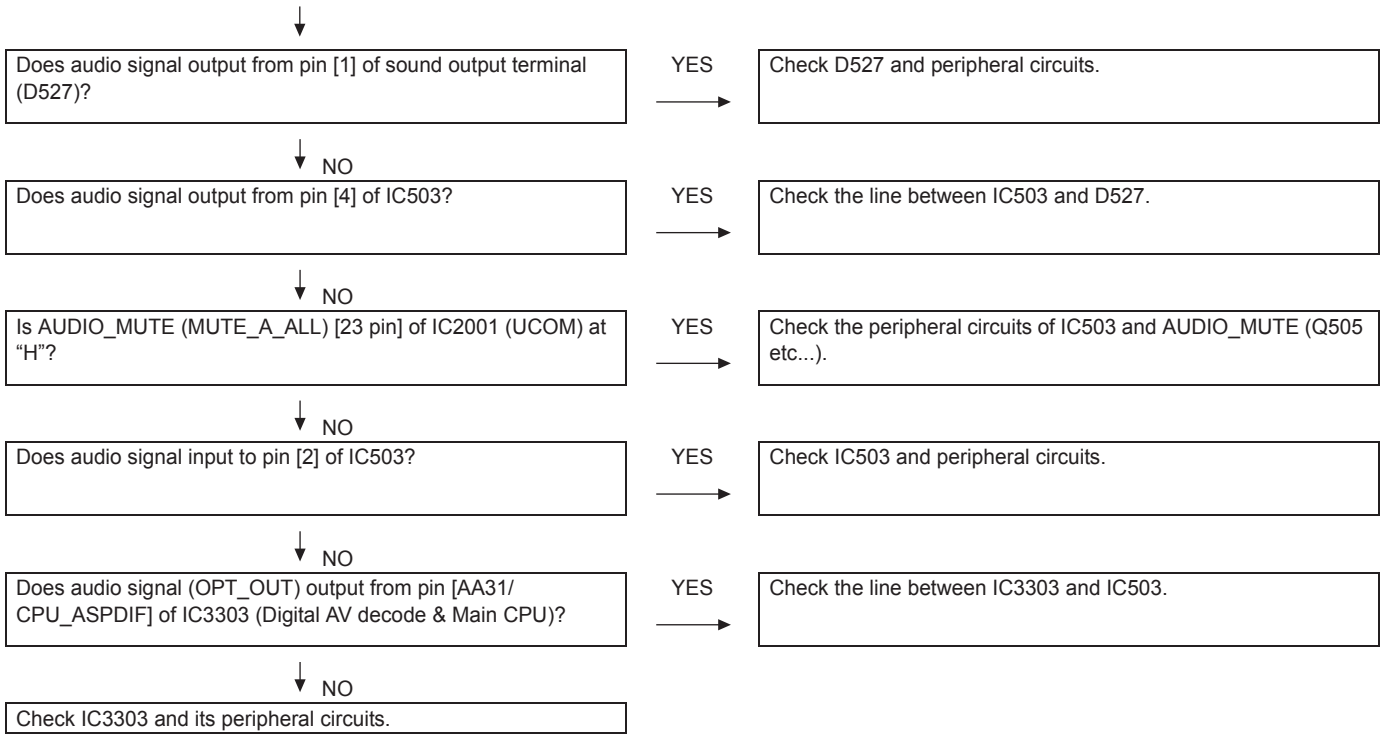

No sound from external output device (4)

Does not the sound of the audio signal output to HDMI1 go out?

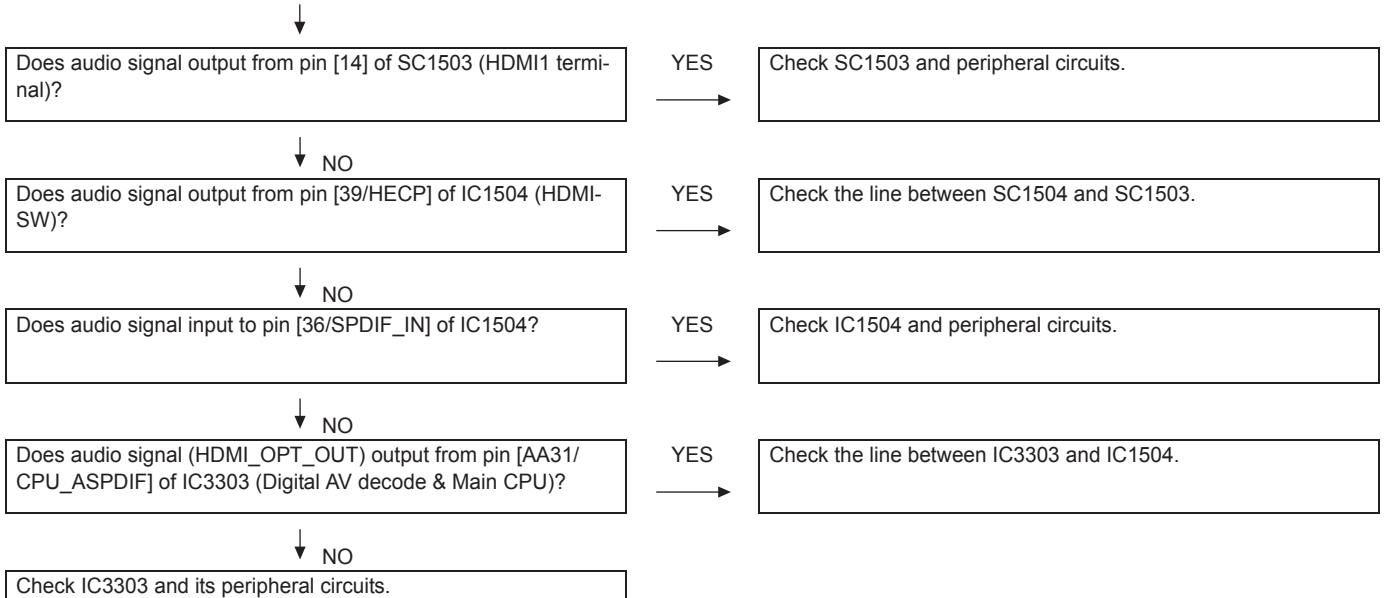

Troubleshooting Table (continued)

No picture on the display (1)

The picture doesn't appear in all modes.

Is the LVDS signal output from IC3303 (DIGITAL_AV_DECODER & MAIN_CPU) respectively?
[LVDS0_D0N/P (B15/A15), LVDS0_D1N/P (B16/A16), LVDS0_D2N/P (B17/A17), LVDS0_CLKN/P_74MHz (B18/A18), LVDS0_D3N/P (B19/A19), LVDS0_D4N/P (B20/A20), LVDS1_D0N/P (C15/D15), LVDS1_D1N/P (E15/E16), LVDS1_D2N/P (C17/D17), LVDS1_CLKN/P_74MHz (E17/E18), LVDS1_D3N/P (C19/D19), LVDS1_D4N/P (E19/E20)]

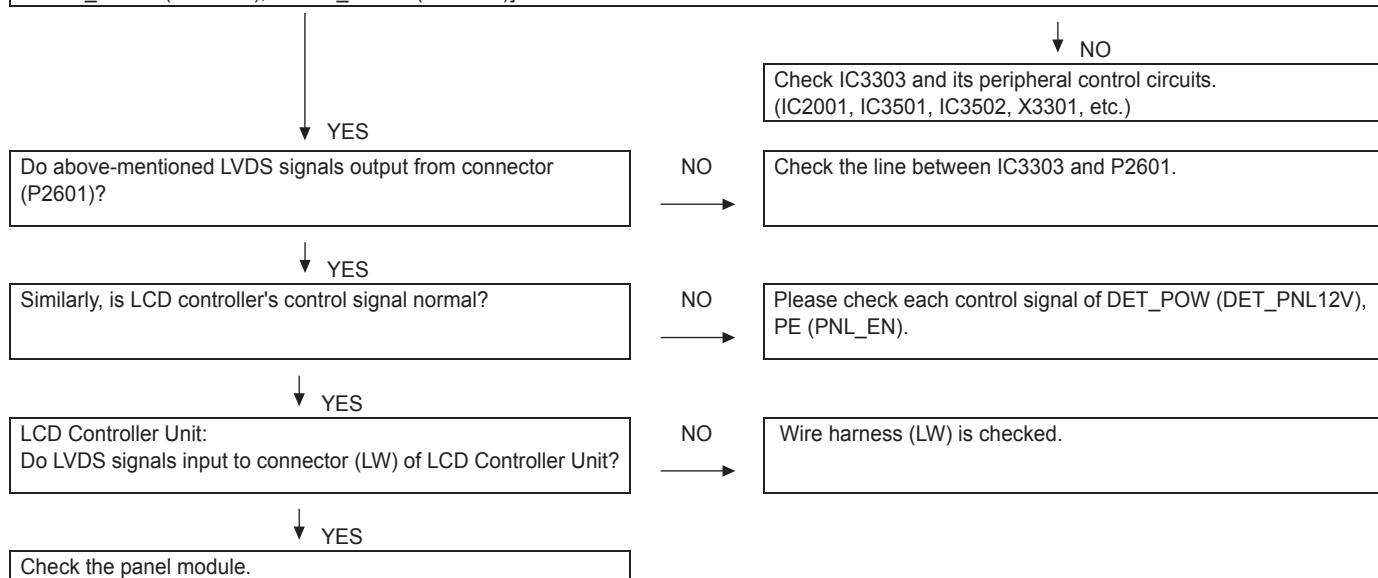

No picture on the display (2)

Does not the picture come out when VHF/UHF is received?

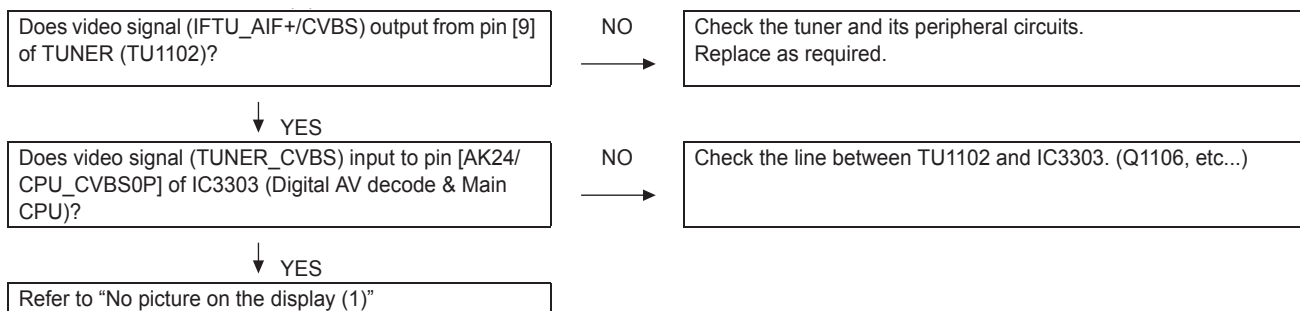

Troubleshooting Table (continued)

No picture on the display (3)



Does not the picture come out when DTV is received?



Refer to "No sound (during the reception of TV (DIGITAL) broadcasting)"

No picture on the display (4)



Does not the picture come out when DTV (Satellite) is received?



Refer to "No sound (during the reception of TV (DIGITAL-Satellite) broadcasting)"

[External input EXT1] No picture on the display (5)



Does not the picture of the CVBS signal input to EXT1 go out?



Does CVBS signal input to pin [20] of EXT1 (SC505)?

NO

Check the setting of an external input device that connects with EXT1.

↓ YES

Does CVBS signal input to pin [AK22/CPU_CVBS2P] of IC3303 (Digital AV decode & Main CPU)?

NO

Check the line between SC505 and IC3303.

↓ YES

Refer to "No picture on the display (1)"

[External input EXT1] No picture on the display (6)



Does not the picture of the Y/C video signal input to EXT1 go out?



Does Y/C video signal input to pins [20/Y, 15/C] of EXT1 (SC505)?

NO

Check the setting of an external input device that connects with EXT1.

↓ YES

Does Y/C signal input to pins [AK22/CPU_CVBS2P, AK19/SC_PR0P] of IC3303 (Digital AV decode & Main CPU)?

NO

Check the line between SC505 and IC3303.

↓ YES

Refer to "No picture on the display (1)"

Troubleshooting Table (continued)

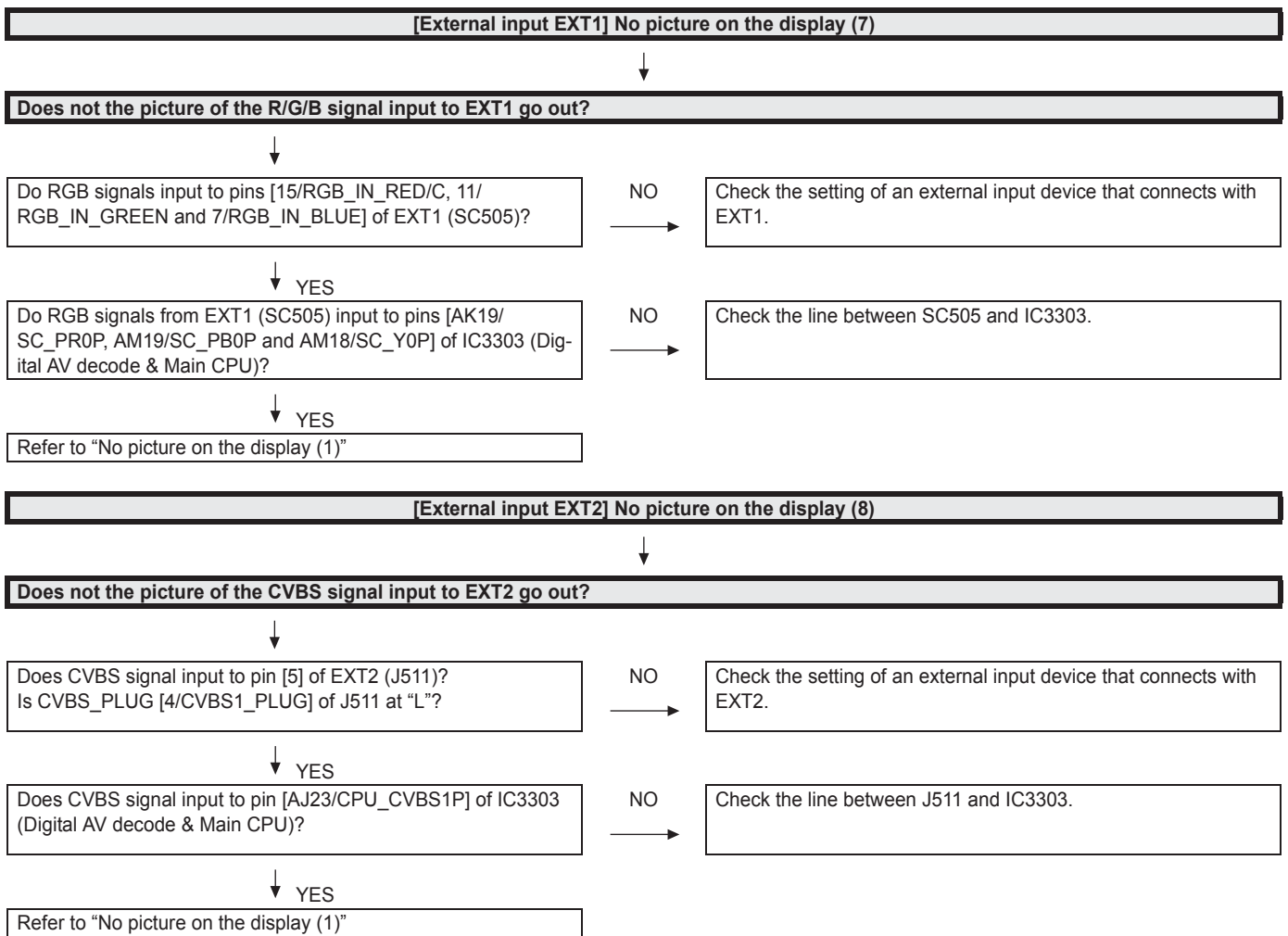

Troubleshooting Table (continued)

[External input EXT3] No picture on the display (9)



Does not the picture of the COMPONENT signal input to EXT3 go out?



Do COMPONENT signals input to pins [13/COMP1_Y, 10/COMP1_Pr, 11/COMP1_Pb] of EXT3 (J511)?

NO



Check the setting of an external input device that connects with EXT3.



YES

Do COMPONENT signals input to pins [AM16/COMP_Y1P], (AJ18/COMP_PR1P) and (AK17/COMP_PB1P) of IC3303 (Digital AV decode & Main CPU)?

NO



Check the line between J511 and IC3303.



YES

Refer to "No picture on the display (1)"

[External input PC] No picture on the display (10)



Does not the picture of the ANALOG-RGB signal input to PC_IN (15pin-D-SUB terminal) go out?



Do ANALOG-RGB and synchronized signal input to pin [(1, 2, 3)/(PC_RED, GREEN, BLUE), (14 and 13)/(PC_VSYNC, H.Sync)] of PC_IN (SC501)?

NO



Check the connection and setup with the external PC_IN devices.



YES

Do ANALOG-RGB and synchronized signal input to pins [AM15/PC_RP, AK15/PC_GP, AK13/PC_BP, and AL13/PC_HSYNC, AM13/PC_VSYNC] of IC3303 (Digital AV decode & Main CPU)?

NO



Check the line between SC501 and IC3303.



YES

Refer to "No picture on the display (1)"

Troubleshooting Table (continued)

[External input HDMI-1/2/3/4] No picture on the display (11)	
↓	
Does not the picture/sound of the HDMI signal input to HDMI-1/2/3/4 go out?	
↓	
<p>Is the Hot plug detection function output from pin [19] of the HDMI-1 (SC1503) normal?</p> <p>Is the Hot plug detection function output from pin [19] of the HDMI-2 (SC1502) normal?</p> <p>Is the Hot plug detection function output from pin [19] of the HDMI-3 (SC1501) normal?</p> <p>Is the Hot plug detection function output from pin [19] of the HDMI-4 (SC1505) normal?</p>	<p>NO → Check the line between SC1503 and pin [59] of IC1504 (HDMI-SW).</p> <p>NO → Check the line between SC1502 and pin [74] of IC1504 (HDMI-SW).</p> <p>NO → Check the line between SC1501 and pin [55] of IC1504 (HDMI-SW).</p> <p>NO → Check the line between SC1505 and pin [50] of IC1504 (HDMI-SW).</p>
↓ YES	
<p>Is EDID data pins [58/HDMI1_SCL, 57/HDMI1_SDA] of IC1504 accessed, and is it read from pins [15, 16] of a HDMI-1 (SC1503)?</p> <p>Is EDID data pins [73/HDMI2_SCL, 72/HDMI2_SDA] of IC1504 accessed, and is it read from pins [15, 16] of a HDMI-2 (SC1502)?</p> <p>Is EDID data pins [54/HDMI3_SCL, 53/HDMI3_SDA] of IC1504 accessed, and is it read from pins [15, 16] of a HDMI-3 (SC1501)?</p> <p>Is EDID data pins [49/HDMI4_SCL, 48/HDMI4_SDA] of IC1504 accessed, and is it read from pins [15, 16] of a HDMI-4 (SC1505)?</p>	<p>NO → Is access possible in the exchange of IC1504?</p>
↓ YES	
<p>Do TMDS signals input to pins [26&27/HDMI1_CLKNP_222.75MHz, 28&29/HDMI1_D0NP, 30&31/HDMI1_D1NP, 32&33/HDMI1_D2NP] of IC1504?</p> <p>Do TMDS signals input to pins [17&18/HDMI2_CLKNP_222.75MHz, 19&20/HDMI2_D0NP, 21&22/HDMI2_D1NP, 23&24/HDMI2_D2NP] of IC1504?</p> <p>Do TMDS signals input to pins [8&9/HDMI3_CLKNP_222.75MHz, 10&11/HDMI3_D0NP, 12&13/HDMI3_D1NP, 14&15/HDMI3_D2NP] of IC1504?</p> <p>Do TMDS signals input to pins [99&100/HDMI4_CLKN_222.75MHz, 1&2/HDMI4_D0NP, 3&4/HDMI4_D1NP, 5&6/HDMI4_D2NP] of IC1504?</p>	<p>NO → Check the line between HDMI-1 (SC1503) and IC1504.</p> <p>NO → Check the line between HDMI-2 (SC1502) and IC1504.</p> <p>NO → Check the line between HDMI-3 (SC1501) and IC1504.</p> <p>NO → Check the line between HDMI-4 (SC1505) and IC1504.</p>
↓ YES	
<p>Do TMDS signals output from pins [87&86/SW_TMDS_CLKNP_222.75MHz_, 85&84/SW_TMDS_D0NP_, 83&82/SW_TMDS_D1NP_, 81&80/SW_TMDS_D2NP_] of IC1504 respectively?</p>	<p>NO → Check the IC1504 and peripheral circuits.</p>
↓ YES	
<p>Do TMDS signals input to pins [AM9&AL9/SW_TMDS_CLKNP_222.75MHz, AM10&AL10/SW_TMDS_D0NP, AM11&AL11/SW_TMDS_D1NP, AM12&AL12/SW_TMDS_D2NP] of IC3303 (Digital AV decode & Main CPU)?</p>	<p>NO → Check the line between IC3303 and IC1504.</p>
↓ YES	
Refer to "Refer to "No picture on the display (1)" or "The sound is not emitted from the Speaker & Woofer though the picture has come out."	

Troubleshooting Table (continued)

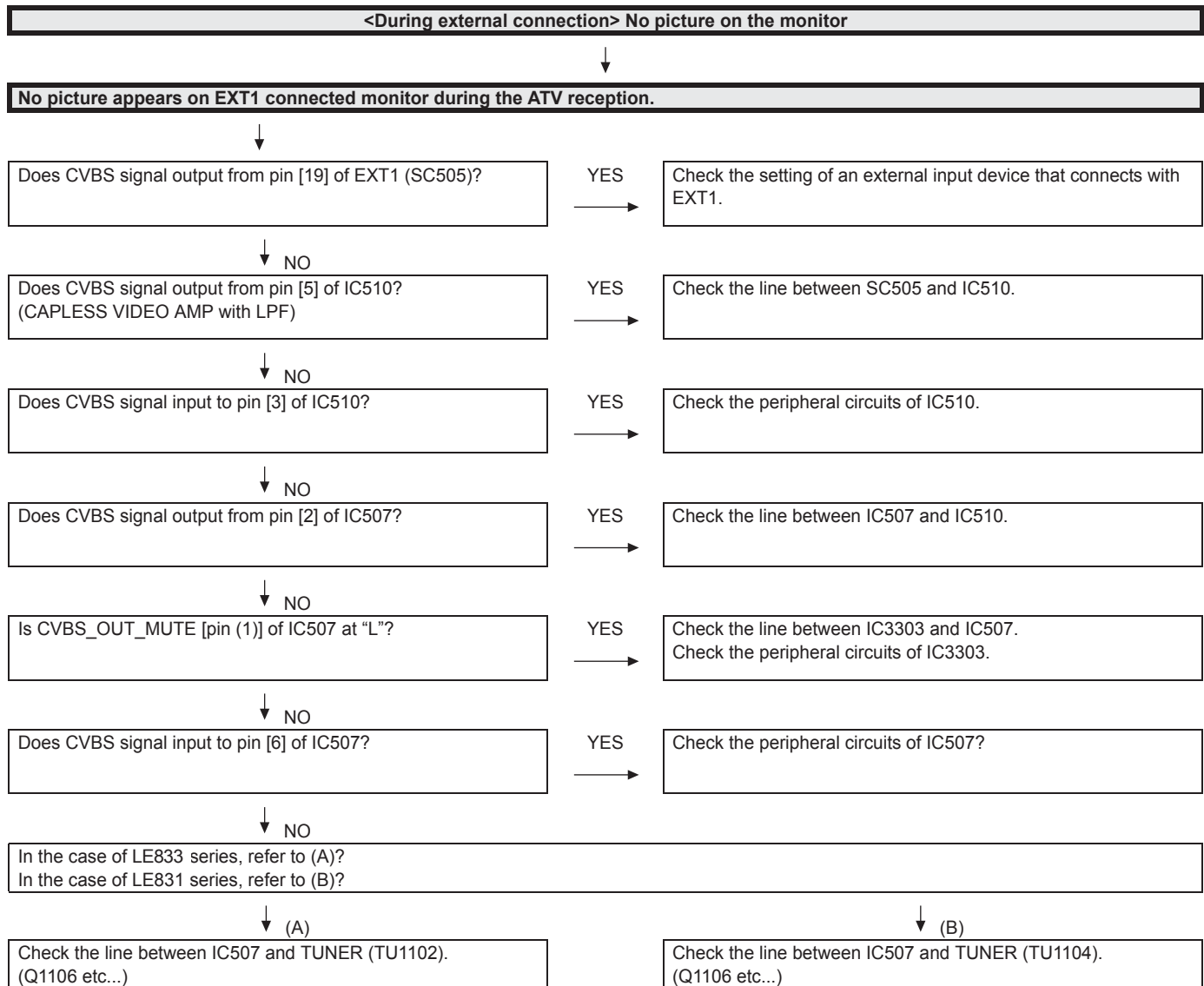

Troubleshooting Table (continued)

<During external connection> No picture on the monitor

No picture appears on EXT1 connected monitor during the DTV reception.

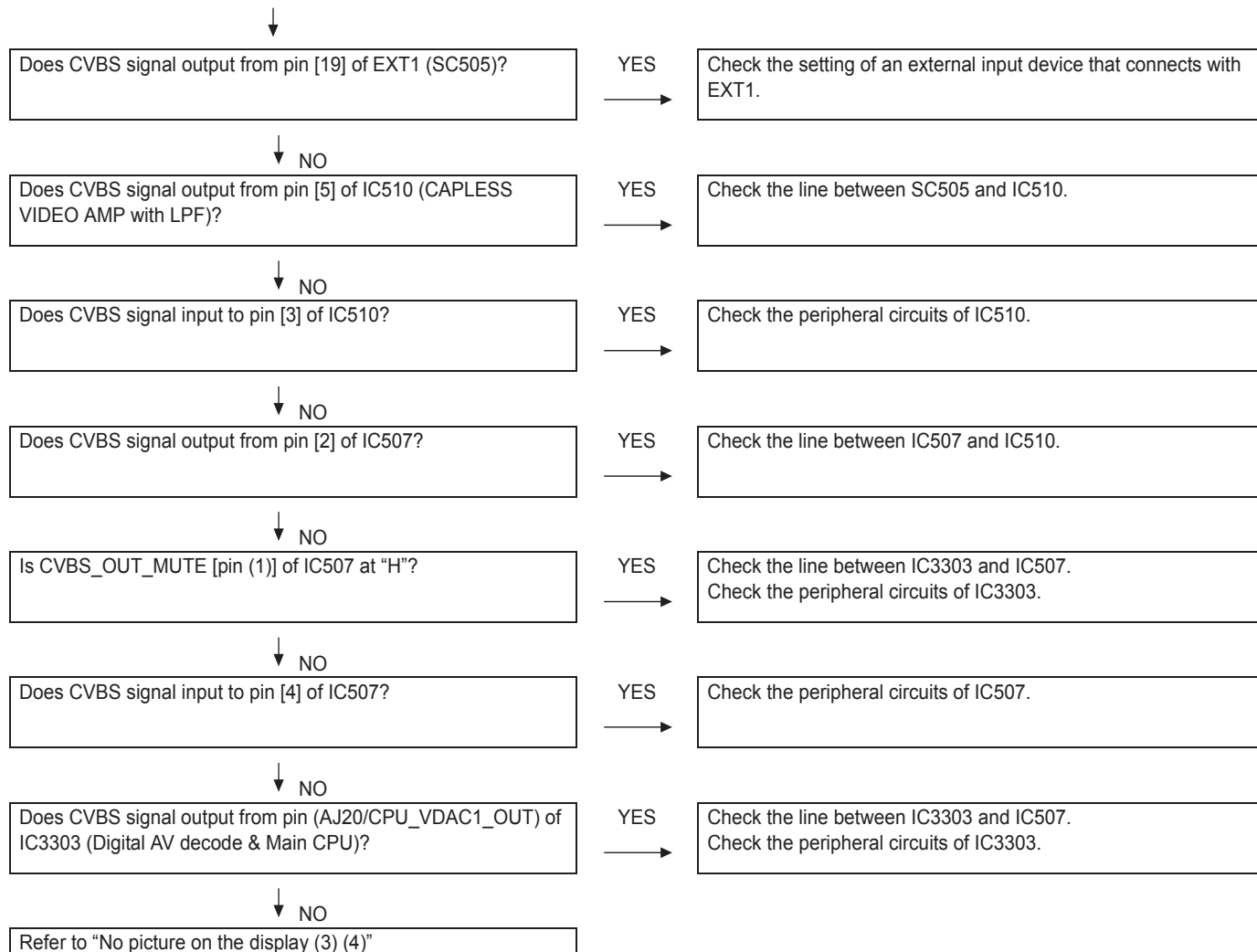

[External input Network] No picture on the display

Does not the signal input to Network go out?

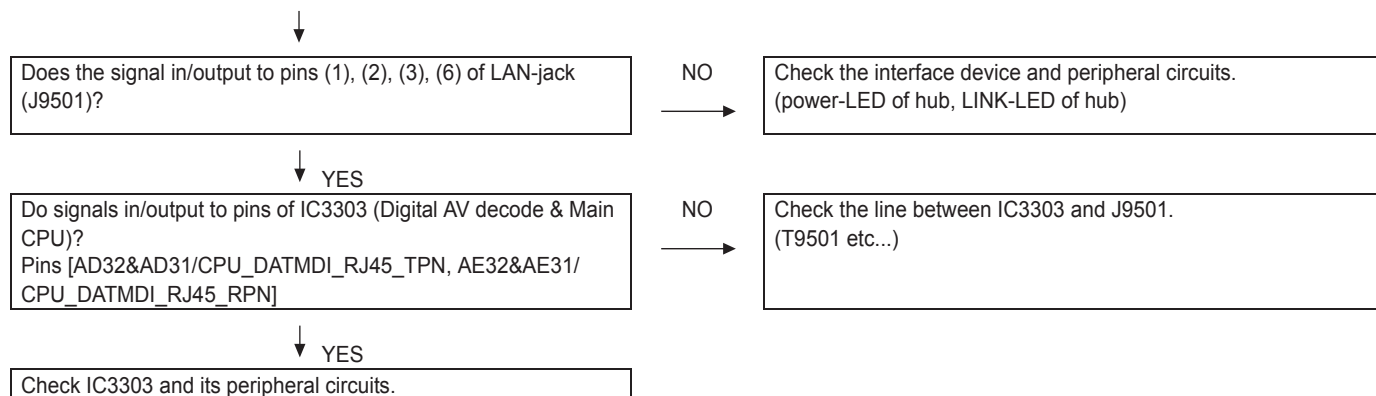

Troubleshooting Table (continued)

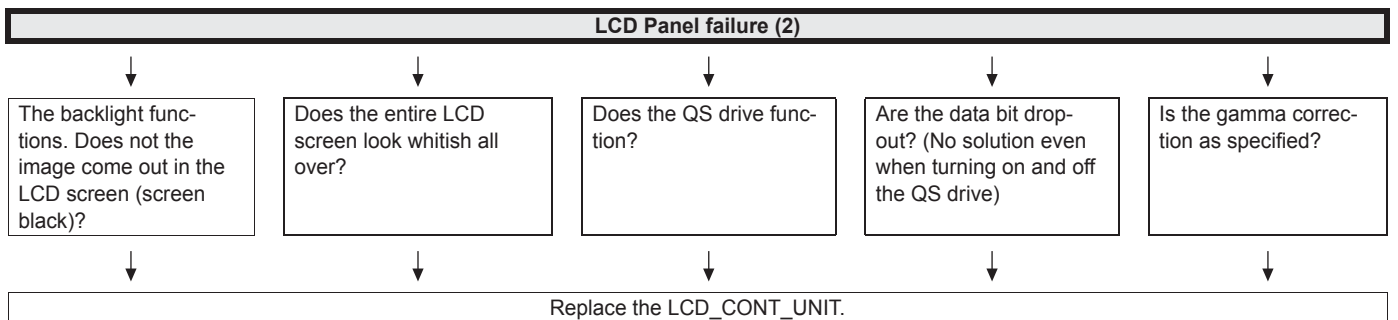
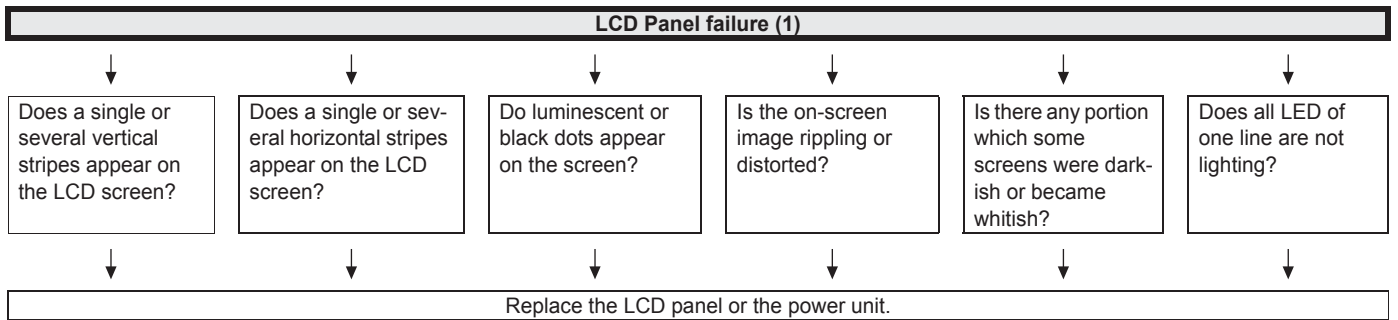
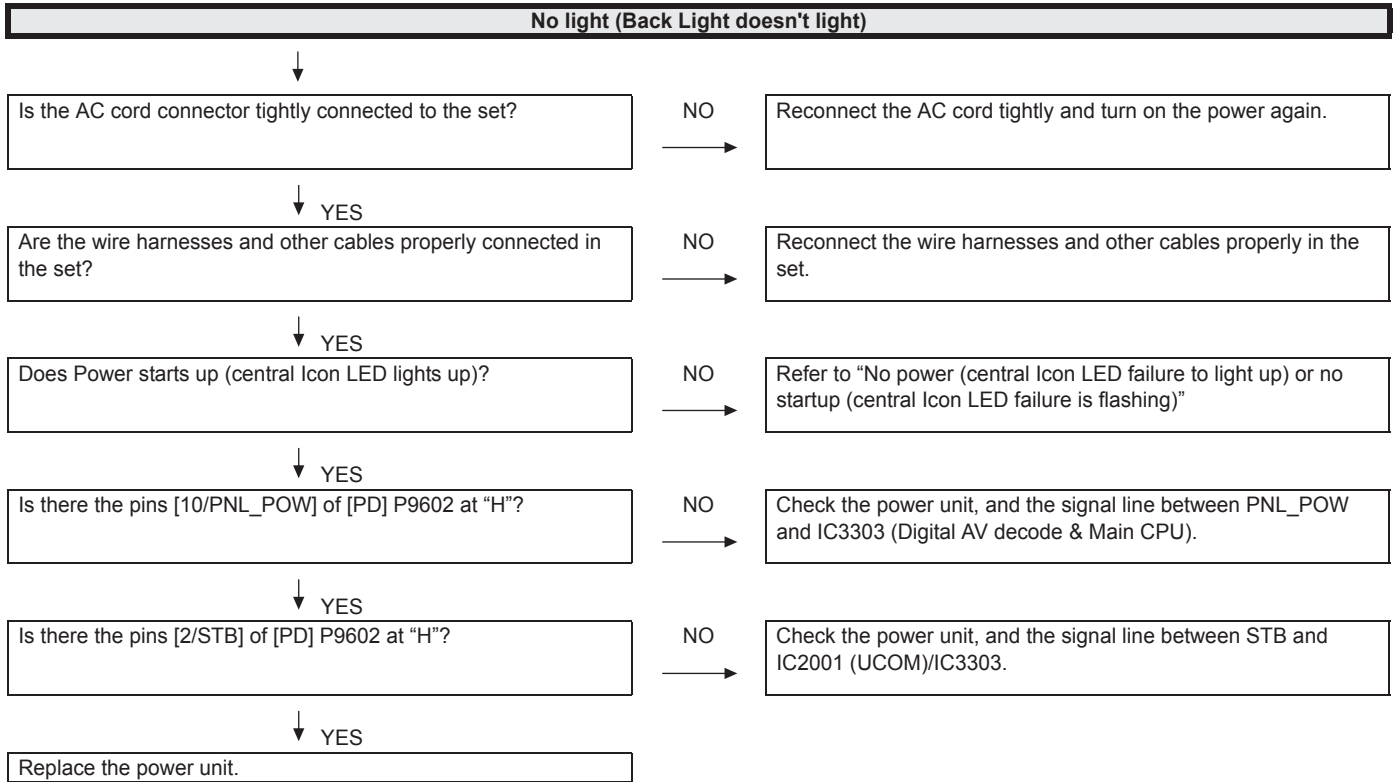

Troubleshooting Table (continued)

[2] LED flashing specification at the time of the error

Display method

- Refer to Table 1.
- LED that can be used are only one of the central icon (Emblem Unit).
This expresses the error situation by combining blinking at low speed and blinking at high speed.
- For this model, the blinking pattern displayed first is only a low-speed blinking.
This expresses **a rough content of the error**.
- For this model, details are displayed by a high-speed blinking by pushing remote control MENU key.
This expresses **details of the error**.
Details are distinguished by the blinking frequency.
- It doesn't return to the outline display again (blink at low speed) by pushing the MENU key (The toggle is not done).
Please confirm "MONITOR ERR CAUSE" of the adjustment Process mode (1/23 page), when the error doesn't reproduce by ha the error.
- The process of the upgrade is expressed by the brightness of point LED that smoothness changes.
- The upgrade completion is expressed by the LED brightness that changes in a staircase pattern.

LED flashing method

<Examination for a rough content of the error>

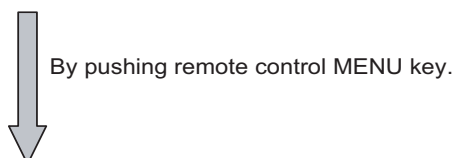
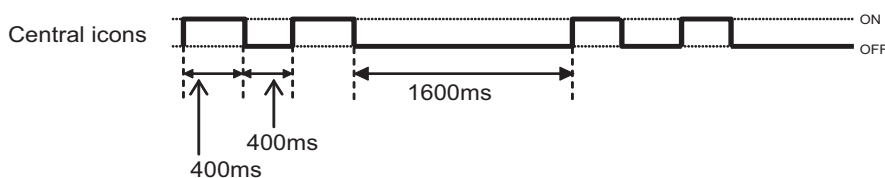

<Examination for details of the error>

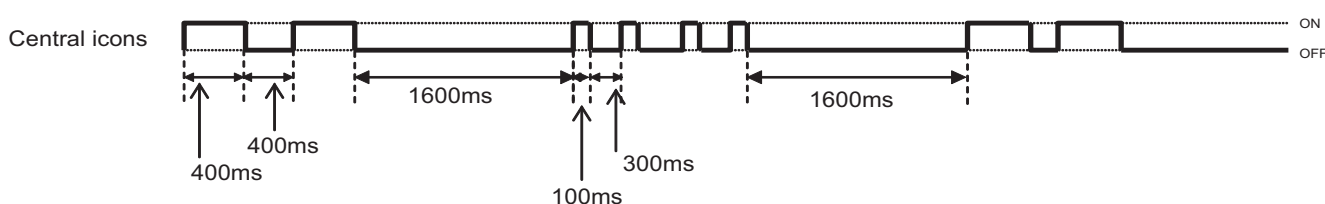

<Upgrade executing>

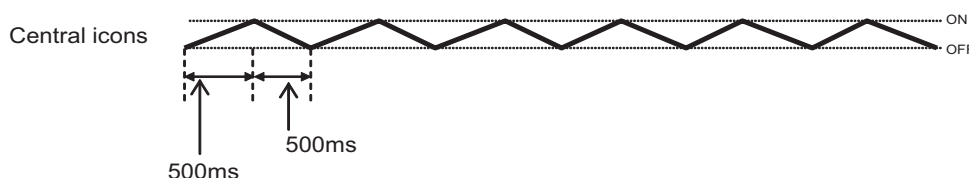

<Upgrade completion>

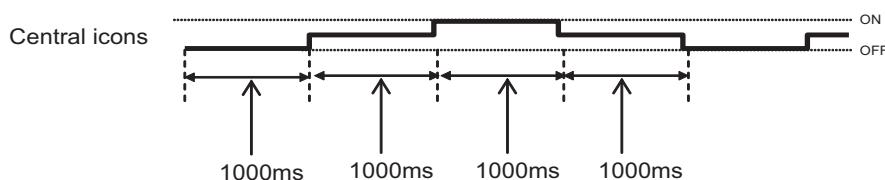

Troubleshooting Table (continued)

Table 1. Concrete flashing pattern

Item	Expression for a rough content		Expression for Details		Cause
	low-speed blinking	high-speed blinking	low-speed blinking	high-speed blinking	
Lamp system failure	Flashes once	—	Flashes once	Flashes once	Lamp error
Power PWB failure (Power failure, etc.)	Flashes twice	—	Flashes twice	Flashes once	Power Error 1 AC_DET error (*2)
				Flashes twice	Power Error 2 UR+13.5V error (*2)
				Flashes 3 times	Power Error 3 D3.3V error (*2)
				Flashes 5 times	Panel power supply error
Main PWB failure (Communication failure, etc.)	Flashes 3 times	—	Flashes 3 times	Flashes once	Initial communication error
				Flashes twice	Start-up confirmation communication error
				Flashes 3 times	Regular communication error
				Flashes 5 times	Other communication error
Others	Flashes 4 times	—	Flashes 4 times	Flashes once	Temperature error
				Flashes twice	Sync error
				Flashes 3 times	Notification from the main microprocessor (*3)
Upgrade executing	smoothness changes.	—	—	—	Version upgrading
Upgrade completion	a staircase pattern.	—	—	—	Version upgrade succeeded
Upgrade failed	—	Flashing (Continuous)	—	—	Version upgrade failed
ROM data failure	—	Flashing (Continuous)	—	—	Start-up after failing version upgrade (*4)

*2: It depends on the system. The power supply error suitable for the product is defined.

*3: For details, refer to ERROR STANDBY CAUSE on the adjustment process screen.

*4: If the boot section is abnormal, there is no flashing (flashing disabled).

MONITOR ERR STBY table

Outline: Communication/Power failure detected by the monitor microprocessor (IC2001) is stored on EEPROM, states can be confirmed in the adjustment process mode.

Location: Page (1/23) of the adjustment process mode: MONITOR ERR CAUSE "0" if there is no error. It is cleared to 0 on the page (2/23) of the adjustment process mode.

Display	Error description	
02	Start-up communication error 2	Initial communication from the main CPU is not received.
03	Start-up communication error 3	Only the initial communication is received.
04	Start-up communication error 4	Until panel information request reception
05	Start-up communication error 5	Until initialization completion reception
06	Start-up communication error 6	Until version notification transmission
07	Start-up communication error 7	Until start-up information notification transmission
08	Start-up communication error 8	Until start-up information response reception
09	Start-up communication error 9	Until time-out setting reception
0A	Communication error A	REQ time-out
0B	Communication error B	Restart time-out during the beginning of time acquisition start-up
0C	Communication error C	Ending sequence time-out
0D	Communication error D	Preset start-up time-out during completion
0E	Communication error E	Download start-up time-out
0F	Communication error F	Time acquisition time-out
11	Communication error H	Regular communication time-out
16	Panel-related error	Lamp failure
1A	Other error 2	Monitor temperature failure
1D	Power supply error 1	PS_ON (AC_DET) failure
1E	Power supply error 2	D_POW (DET_13V) failure
1F	Power supply error 3	D_POW (DET_D3V3) failure
21	Power supply error 5	Panel power failure
23	Other error 3	Error standby request from the main CPU

Troubleshooting Table (continued)

LED flashing timing chart at the time of the error



1) Low-speed blinking

Error type	Expression of Central Icon LED	
Lamp failure low-speed blinking Flashes once	H: ON L: OFF	Refer to "Lamp failure details". LOW/High blinking by pressing the [MENU] key on the remote control.
Power failure low-speed blinking Flashes twice	H: ON L: OFF	Refer to "Power failure details". LOW/High blinking by pressing the [MENU] key on the remote control.
Communication failure with main CPU low-speed blinking Flashes 3 times	H: ON L: OFF	Refer to "Communication failure details". LOW/High blinking by pressing the [MENU] key on the remote control. Communication line failure or main CPU communication failure.
Others low-speed blinking Flashes 4 times	H: ON L: OFF	Refer to "Other failure details". LOW/High blinking by pressing the [MENU] key on the remote control.

2) Lamp failure details (Low-speed blinking: Flashes once + High-speed blinking)





Error type	Expression of Central Icon LED	Note: Pins are monitor microprocessor pins unless otherwise specified (IC2001).
Lamp failure Flashes once (High speed)	H: ON L: OFF	LAMP_ERR (19pin): Abnormal H. Confirmed after 8 consecutive detections at 64ms intervals (detected only when the backlight is on). NOTE: After 5 detection counts, the lamp cannot be activated except in the monitoring process. To confirm the problem, "Lamp Error detection off-mode" is prepared. This mode compulsorily starts the set disregarding the count. Please refer to [9. Lamp Error detection (ADJUSTMENT PROCEDURE)]

3) Power failure details (Low-speed blinking: Flashes twice + High-speed blinking)



Error type	Expression of Central Icon LED	Note: Pins are monitor microprocessor pins unless otherwise specified (IC2001).
PS_ON AC_DET failure Flashes once (High speed)	H: ON L: OFF	AC_DET (28pin): Abnormal (L). If error is detected during start-up or operation, the power is turned on again by interrupt handling (instantaneous blackout processing).
SM_POW Main 13V failure Flashes twice (High speed)	H: ON L: OFF	DET_13V (32pin): Abnormal (L). Main 13V is not applied. If error is detected during start-up or operation, the power is turned on again by polling.
D_POW Digital 3.3V failure Flashes 3 times (High speed)	H: ON L: OFF	DET_D3V3 (33pin): abnormal (L). Digital 3.3V is not applied. If error is detected during start-up or operation, the power is turned on again by polling.
PANEL_POW Panel 12V failure Flashes 5 times (High speed)	H: ON L: OFF	DET_PNL12V (34pin): abnormal (L). DET_PNL12V is not applied. Detection starts after receiving command from Panel Power ON. The power is turned off by polling.

Troubleshooting Table (continued)

4) Communication failure details (Low-speed blinking: Flashes 3 times + High-speed blinking)

Error type	Expression of Central Icon LED	Note: Basically, debug print logs are analyzed or communication logs are analyzed by a bus monitor.
Initial communication reception failure Flashes once (High speed)	H: ON  L: OFF	Initial communication from the main CPU is not received. (Request for the monitor model No. is not received.) → Communication line failure or main CPU start-up failure
Start-up confirmation reception failure Flashes twice (High speed)	H: ON  L: OFF	Start-up reason confirmation from the main CPU cannot be received. (Startup communication until start-up reason notification command is not received.) → Main CPU start-up failure or monitor microprocessor reception failure
Regular communication failure Flashes 3 times (High speed)	H: ON  L: OFF	Regular communication that is performed at 1 second intervals in the normal operation is interrupted. → Main CPU operation failure or monitor microprocessor reception failure
Other communication failure Flashes 5 times (High speed)	H: ON  L: OFF	When a request (PM_REQ=H) is sent from the main microprocessor, the request command is not output from the main CPU, etc. → Main CPU operation failure or monitor microprocessor reception failure

5) Other failure details (Low-speed blinking: Flashes 4 times + High-speed blinking)

Error type	Expression of Central Icon LED	Note: Pins are monitor microprocessor pins unless otherwise specified (IC2001).
Monitor temperature failure Flashes once (High speed)	H: ON  L: OFF	If the panel temperature is 60°C or more for 15s or more in a row, CAUTION appears on the OSD (flashes in red in the lower right screen). If the panel temperature is 60°C or more for 25s or more in a row, error standby is activated. (MONITOR MAX TEMP on page (12/23) of the adjustment process: Change AD value for temperature failure): Thermistor
Main failure Flashes 3 times (High speed)	H: ON  L: OFF	Main microprocessor detection error (CPU temperature error, etc.) Details are displayed on page (1/23) of the adjustment process for the main microprocessor.

MAJOR ICs INFORMATION

1. General ICs Information

REF NO	Name	Part Code	Description
[MAIN UNIT]			
IC8401	RH-iXD287WJQZQ	Flash	This IC is 2048Mbit NAND flash memory. This IC stores the software data that processes the system of TV such as the graphic processing, the LCD controls, and backlights etc.
IC3303	RH-iXD220WJQZQ	Digital AV decode Main CPU	This IC is Video Processor & MAIN CPU. In this IC, the decode processing and the video signal processing are done. Moreover, OSD is generated here and added to a picture signal.
IC2001	RH-iXD241WJQZQ for service (RH-iXD241WJN2Q)	UCOM	The monitor microprocessor is intended to communicate with the main CPU and to operate the system. It also controls power of the entire system.
IC3501/3502	RH-iXD242WJQZQ	DDR	This IC is 2GB DDR2 SDRAM. This IC operates as a memory of IC3303 (Digital AV decode & Main CPU).
IC8455	VHiBR24S64F-1Y	64K bit E2PROM	The BR24S64W is a 64Kbit-2-wire (I2C bus type) serial EEPROM that can be programmed electrically. This IC stores the menu data and the adjustment value data of adjustment process mode etc. The data is given out by commands from the main microprocessor.
IC506	VHiM3221EiP-1Y	RS232C-DRIVER	The MAX3221E is a single driver, single receiver RS-232 solution operating from a single Vcc supply. The RS-232 pins provide IEC G1000-4-2 ESD Protection. The device meets the requirements of TIA/EIA-232-F and provides the electrical interface between an asynchronous communication controller and the serial-port connector. The charge pump and four small external capacitors allow operation from a single 3V to 5.5V supply.
IC4402	VHiMT5135AE-1Q	CI controller DTB-T/C Demodulator	This is a control IC for PCMCIA cards. This controls information on IC cards inserted into the PCMCIA card slot (SC4401) or information on software version upgrade cards saved on flash memories to transfer the data to CPUs and memories.
IC2005	VHiR24002AS-1Y	2K bit E2PROM	This is a 2Kbit-2-wire (I2C bus type) serial EEPROM that can be programmed electrically. This IC stores the menu data and the adjustment value data of adjustment process mode etc. The data is given out by commands from the main microprocessor.
IC1504	VHiSi9387+-1Q	HDMI_Port_Processor	The SiI9387 HDMI port processor is the second generation of HDMI devices that support revision 1.4 of the HDMI specification. The main feature is as follows. 1) 5-input, 1-output HDMI port processor. 2) Audio Return Channel that allows an S/PDIF uplink from HDMI sink device to an HDMI source available in one receiver port. 3) Integrated TMDS receiver and transmitter cores capable of receiving and transmitting at 2.25Gbps. 4) Supports video resolutions up to 1080p, 60Hz, 12bit or 720p/1080i, 120Hz, 12bit. 5) Receiver fully comply with DVI1.0, HDCP and several optional 3D formats described in the HDMI1.4 specifications.
IC9505	VHiPD720114-1Q	Ethernet Bus Interface	The IC is a USB 2.0 hub device that complies with the Universal Serial Bus (USB) Specification Revision 2.0 and works up to 480 Mbps. USB 2.0 compliant transceivers are integrated for upstream and all downstream ports. The IC4 works backward compatible either when any one of the downstream ports is connected to a USB 1.1 compliant device, or when the upstream port is connected to a USB 1.1 compliant host.
IC2703	VHiYDA164BZ-1Y	Audio-AMP	This IC is digital audio power amplifier with digital audio interface. The power-supply voltage is corresponded to A.5V~18V and the maximum output is 20Wx2ch.
IC1105	RH-iXC563WJQZY	LNB supply and control	It is IC for amplifying the feeble electric wave sent from satellite broadcasting on the level which can treat a decoder, and changing and processing signal.

Power Unit Layout RUNTKA847WJN1

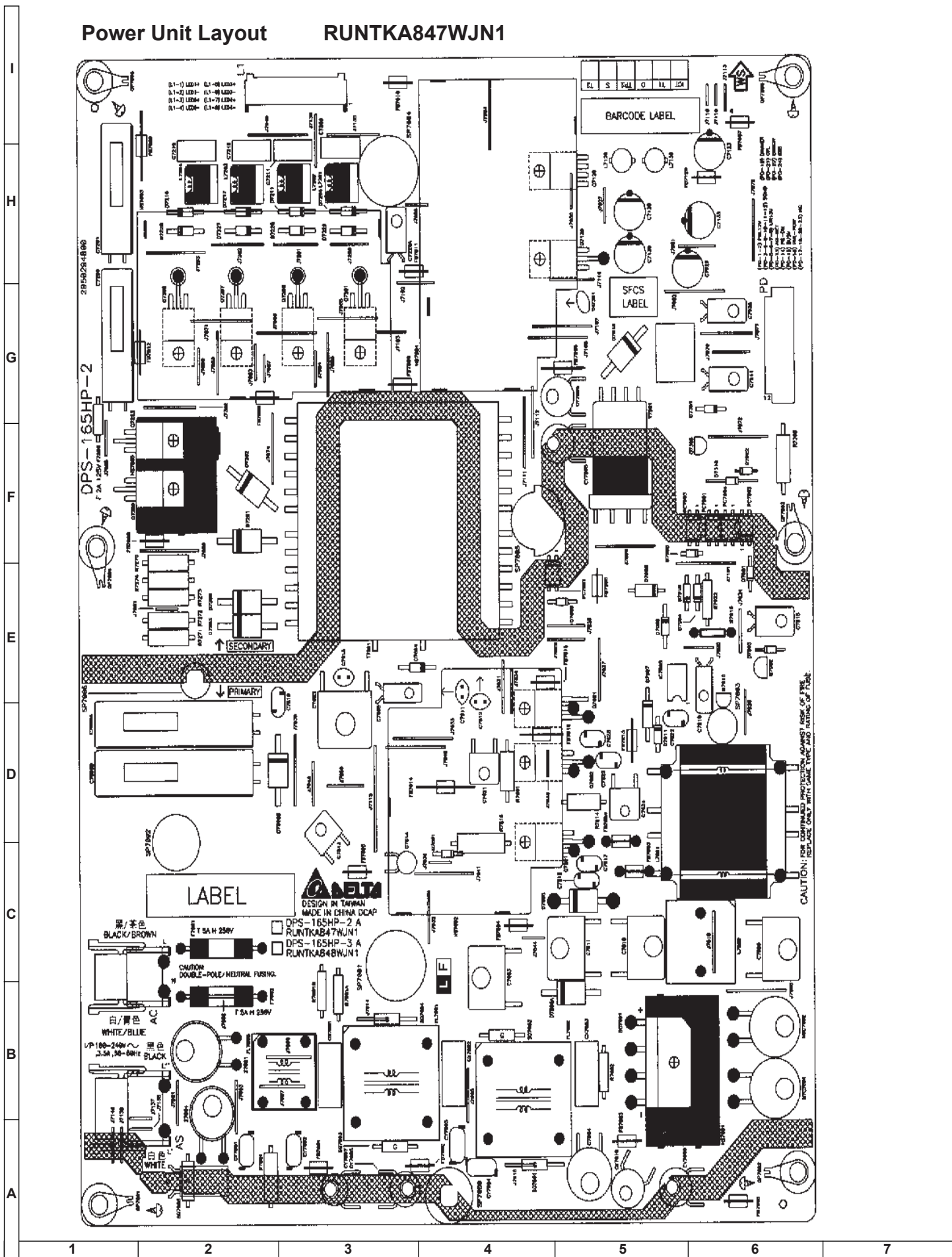

LCD Controller Unit Layout RUNTKA4910TPZ

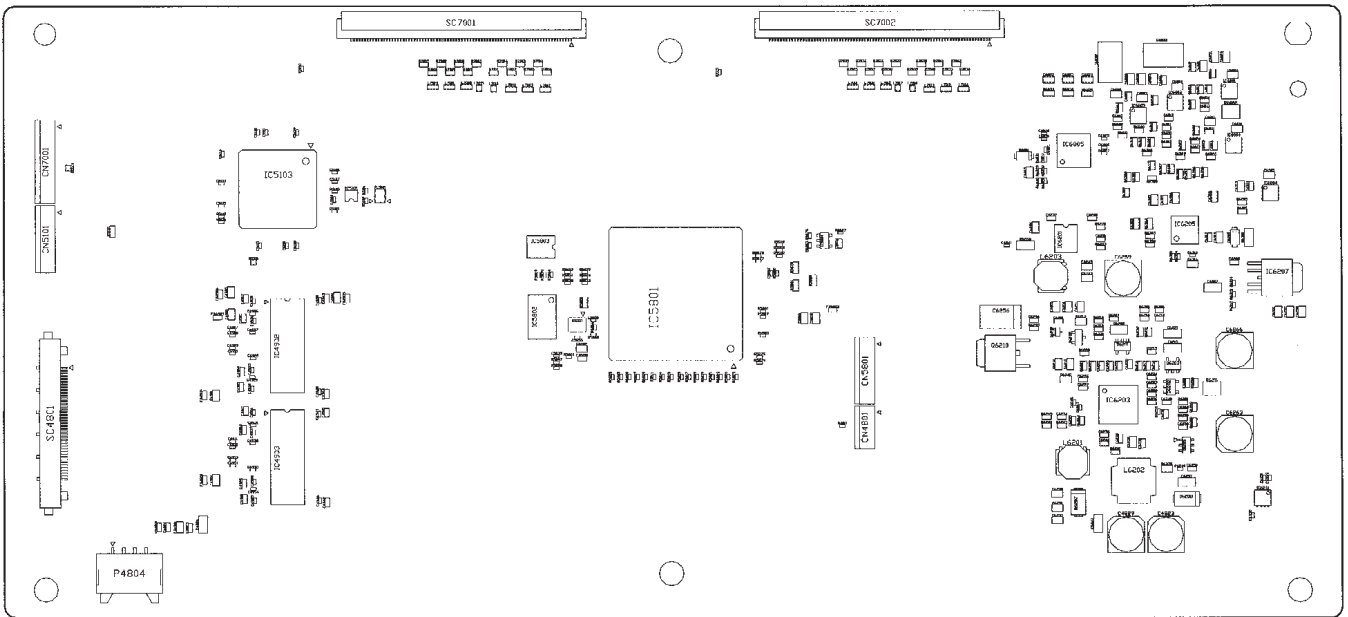

RC Unit Layout QPWBNF494WJZZ

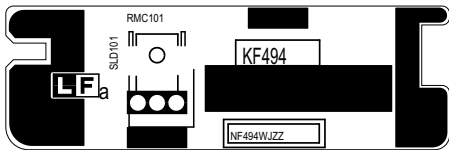

Icon Unit Layout QPWBNF770WJZZ

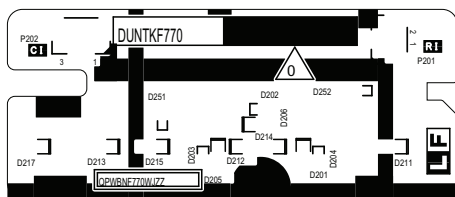

I
H
G
F
E
D
C
B
A

1 2 3 4 5 6 7

OVERALL WIRING DIAGRAM

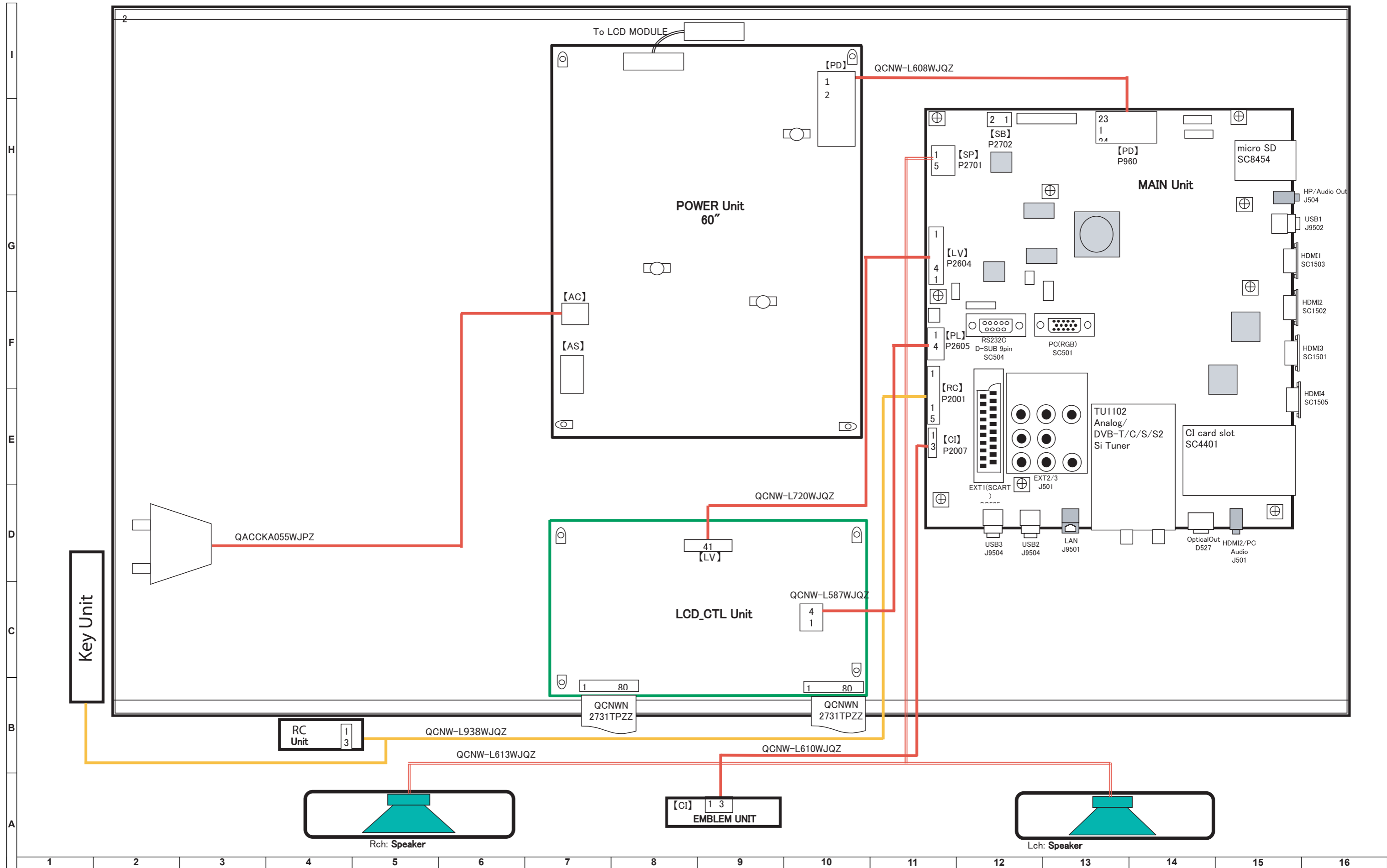

SYSTEM BLOCK DIAGRAM

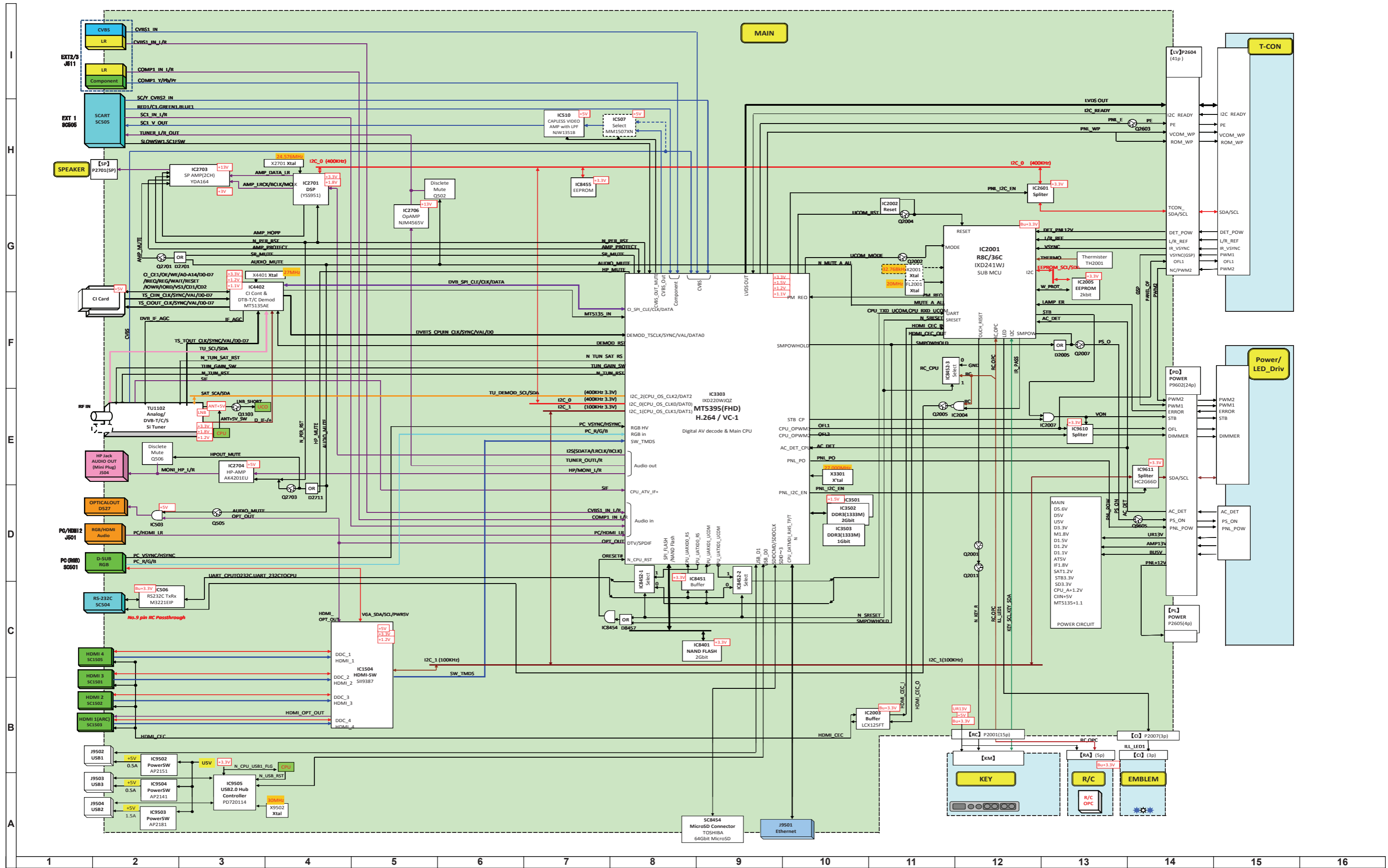

SCHEMATIC DIAGRAMS

Description:

VOLTAGE MEASUREMENT CONDITION:

1. The voltages at test points are measured on the stable supply voltage of AC 230V. Signals are fed by a color bar signal generator for servicing purpose and the above voltages are measured with a 20k ohm/V tester.

INDICATION OF RESISTOR & CAPACITOR:

RESISTOR

1. The unit of resistance "Ω" is omitted. (K=kΩ=1000 Ω, M=MΩ).
2. All resistors are ± 5%, unless otherwise noted. (J= ± 5%, F= ± 1%, D= ± 0.5%)
3. All resistors are 1/16W, unless otherwise noted.
4. All resistors are Carbon type, unless otherwise noted.

- (C): Solid (W): Cement
(S): Oxide Film (T): Special
(N): Metal Coating

CAPACITOR

1. All capacitors are μF, unless otherwise noted. (P=pF=μμ F).
2. All capacitors are 50V, unless otherwise noted.
3. All capacitors are Ceramic type, unless otherwise noted.

- (ML): Mylar (TA): Tantalum
(PF): Polypro Film (ST): Styrol

CAUTION:

This circuit diagram is original one, therefore there may be a slight difference from yours.

IMPORTANT SAFETY NOTICE:

PARTS MARKED WITH "⚠" () ARE IMPORTANT FOR MAINTAINING THE SAFETY OF THE SET. BE SURE TO REPLACE THESE PARTS WITH SPECIFIED ONES FOR MAINTAINING THE SAFETY AND PERFORMANCE OF THE SET.

RC Unit Diagram DUNTF494WE

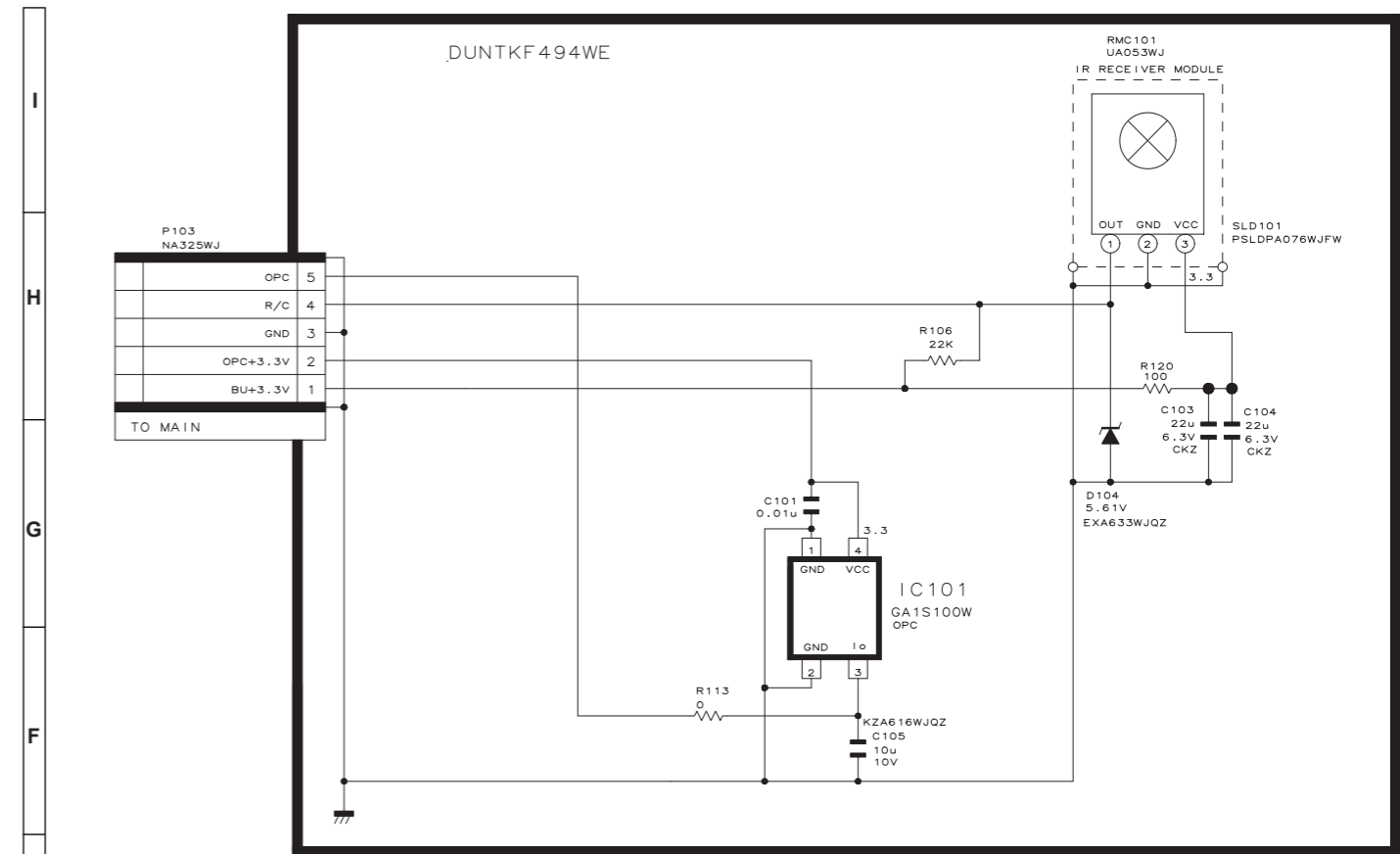

Sharp Logo Unit Diagram DUNTKF770WE53 1 / 3

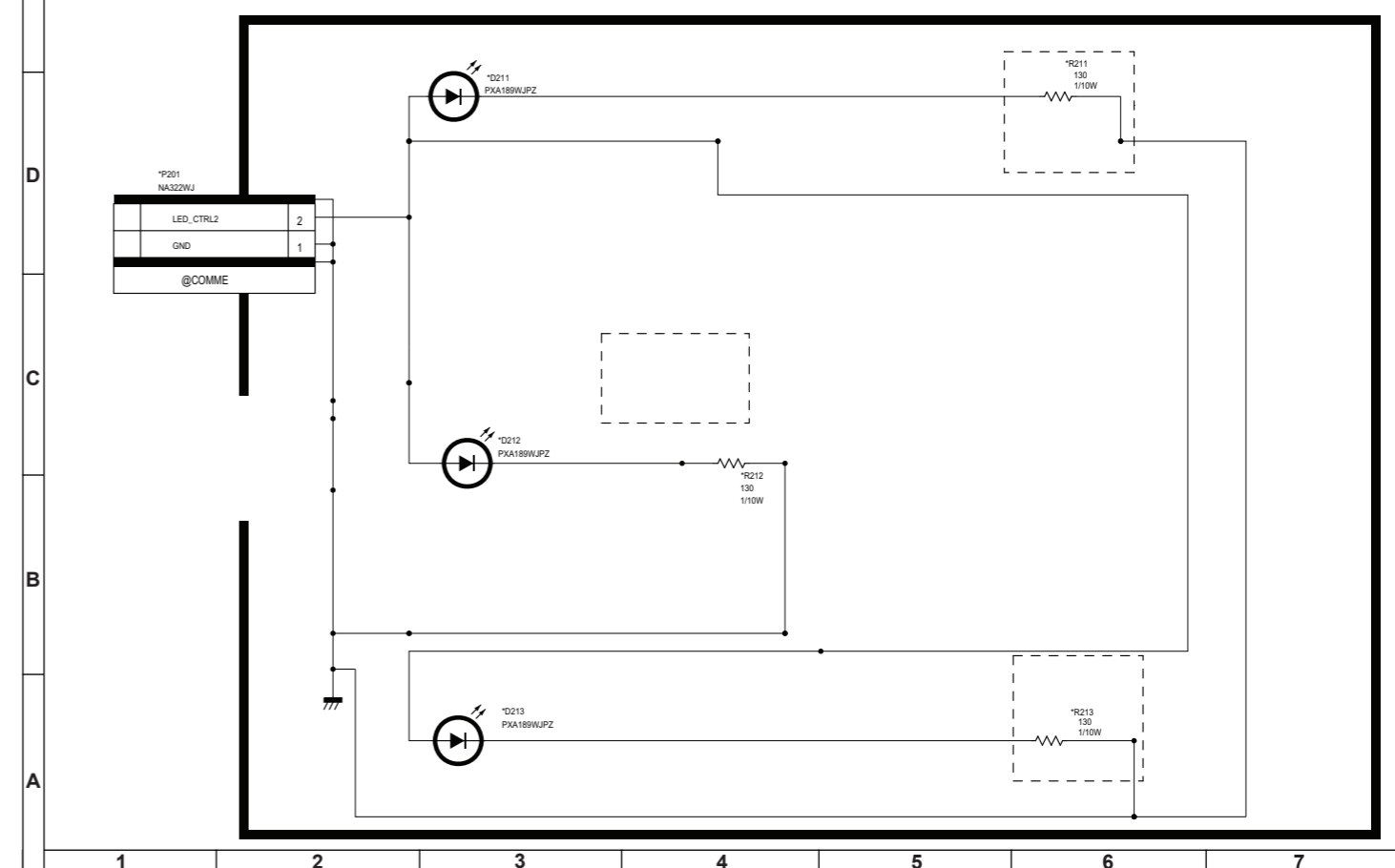

2D Center Icon Unit Diagram DUNTKF770WE53 2 / 3

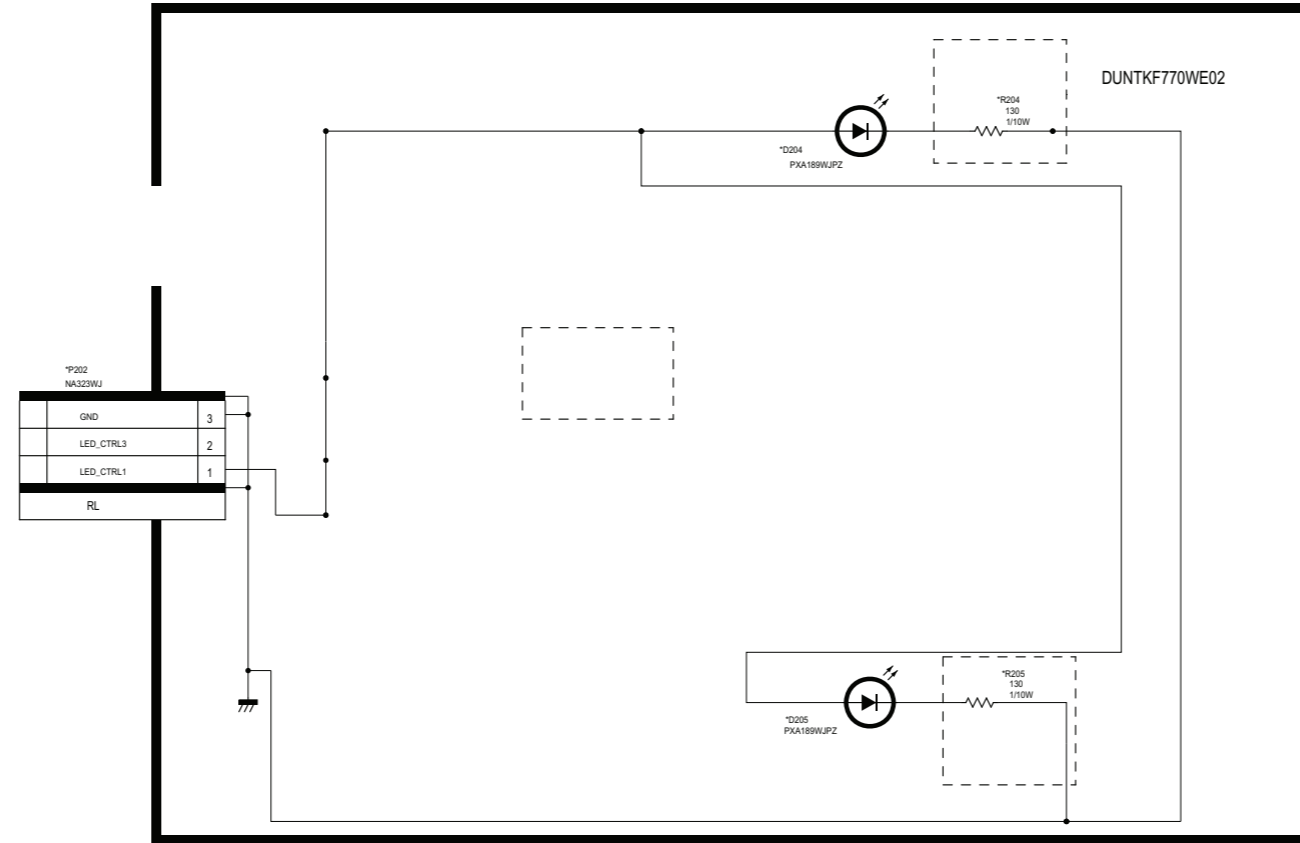

3D Center Icon Unit Diagram DUNTKF770WE53 3 / 3

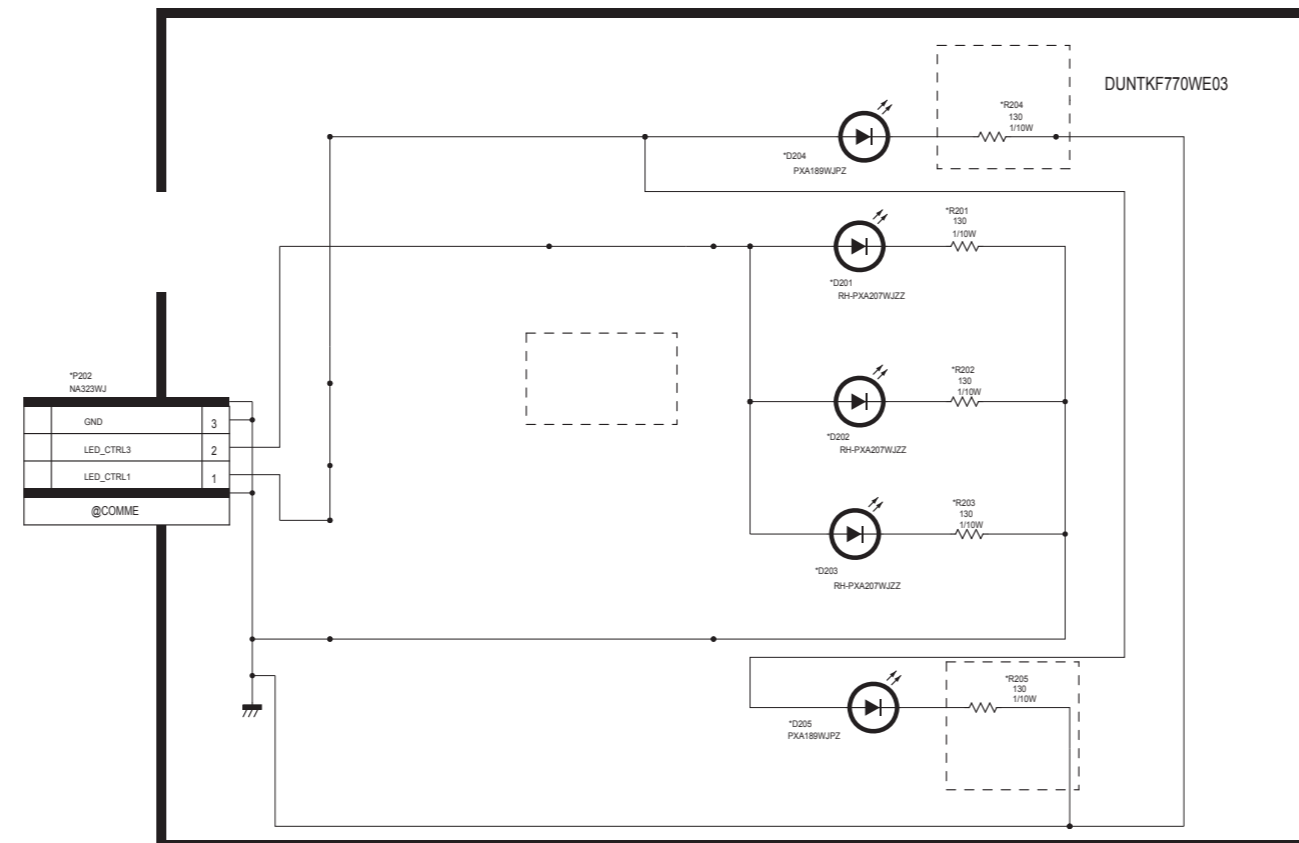

I
H
G
F
E
D
C
B
A

1 2 3 4 5 6 7 8 9 10 11 12 13 14 15 16

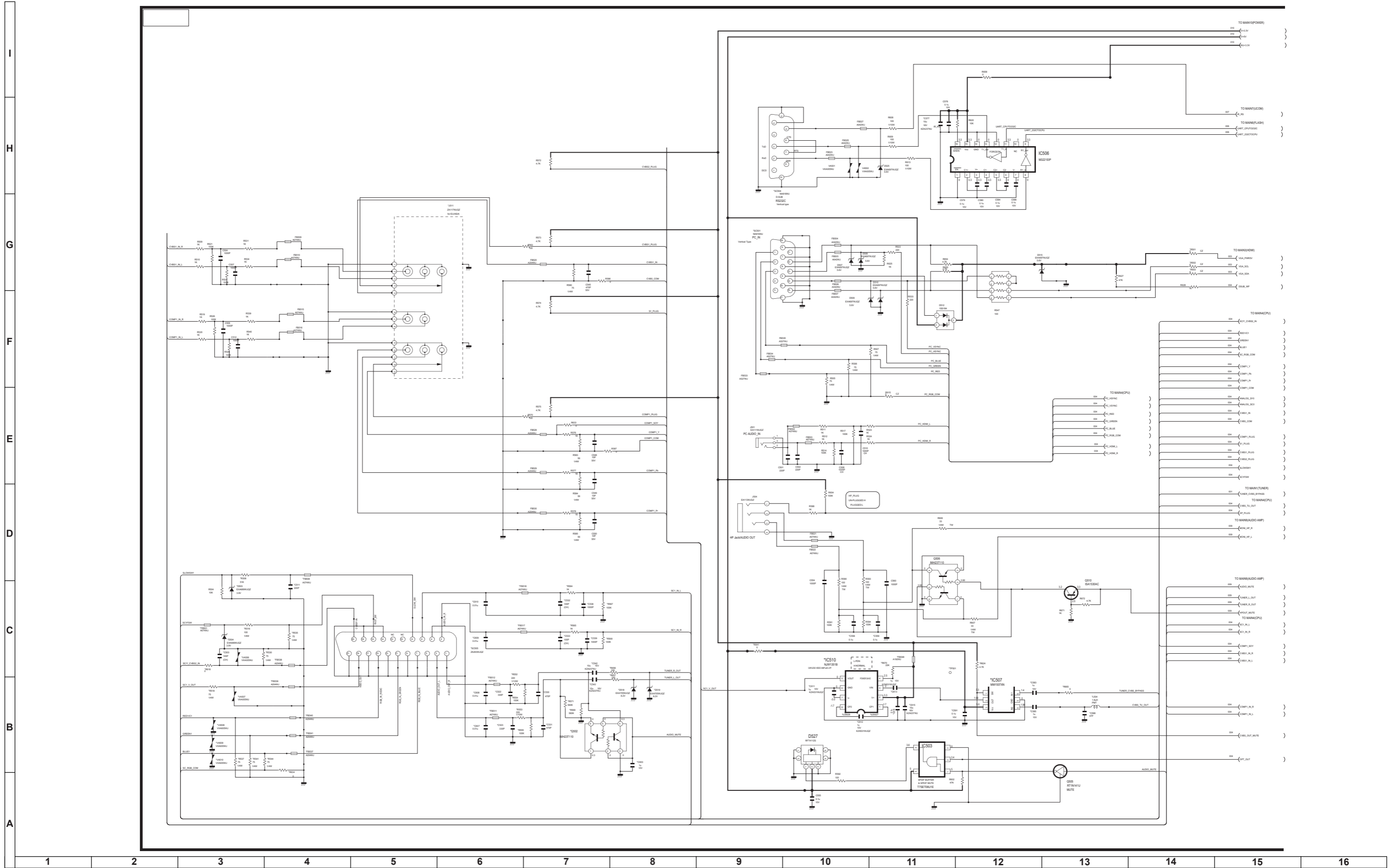

Main Unit Diagram DUNTKF733WE 3/12 (HDMI)

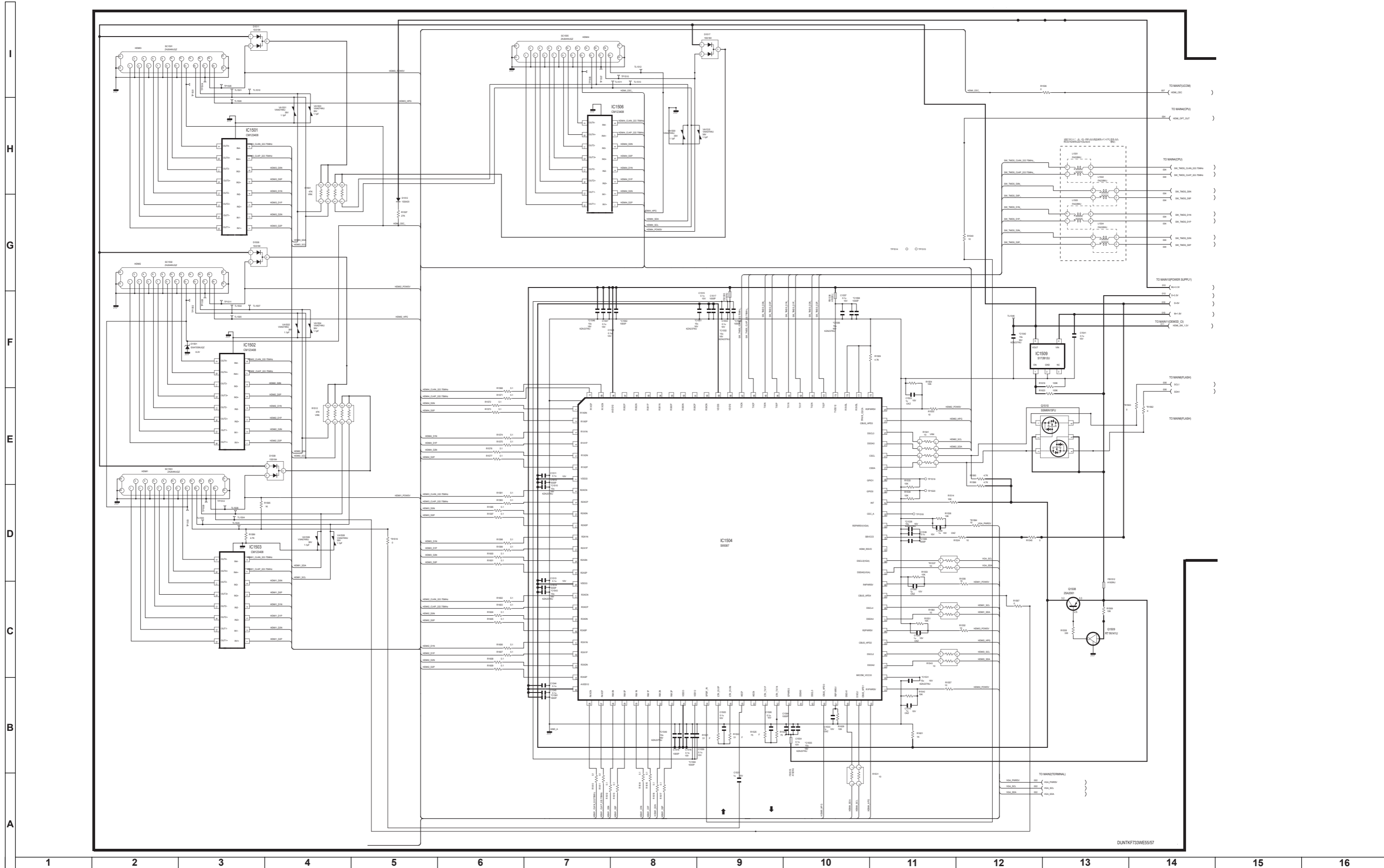

Main Unit Diagram DUNTKF733WE 6/12 (Flash)

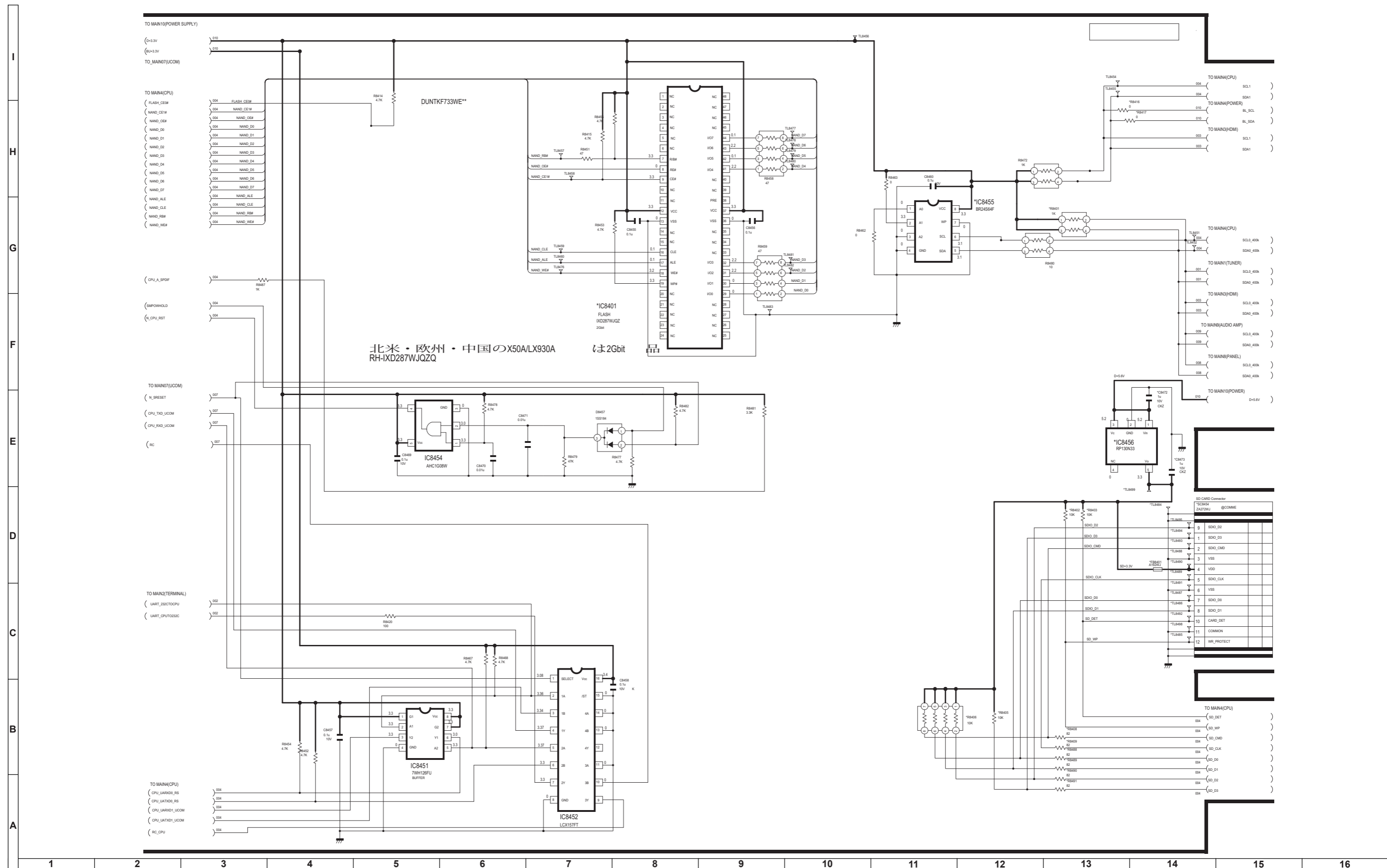

Main Unit Diagram DUNTKF733WE 7/12 (UCOM)

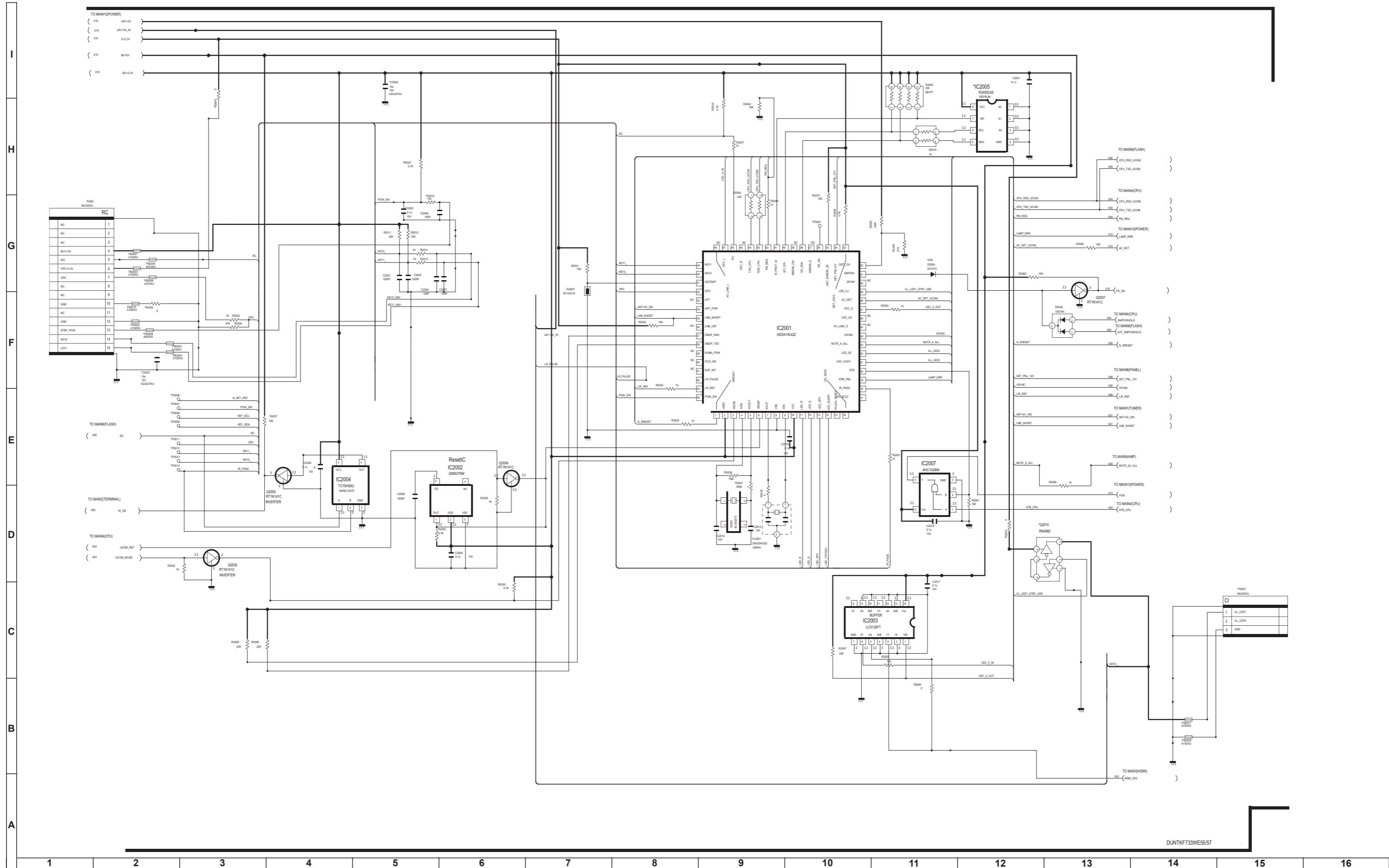

Main Unit Diagram DUNTKF733WE 9/12 (Audio Amp)

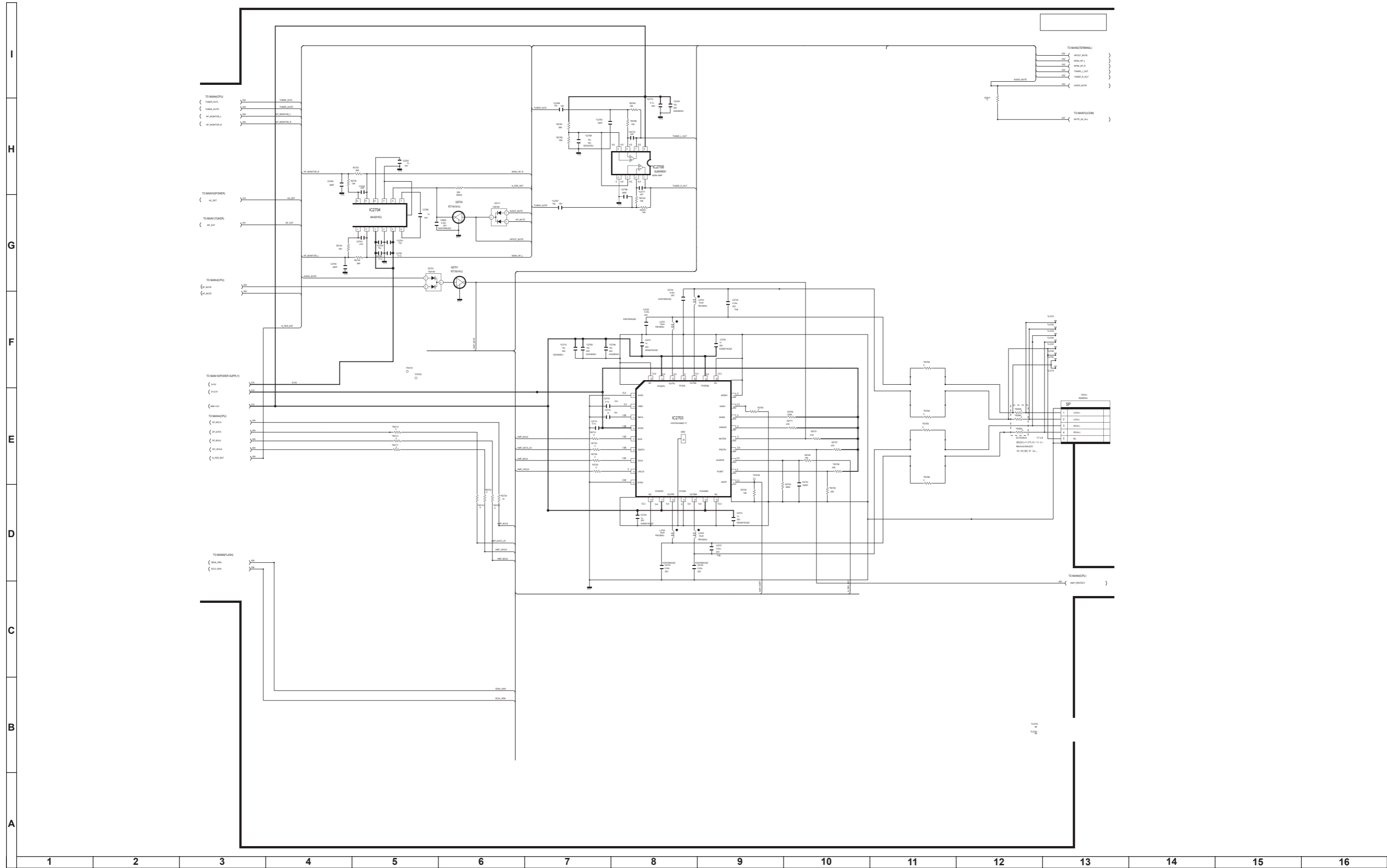

Main Unit Diagram DUNTKF733WE 10/12 (Power)

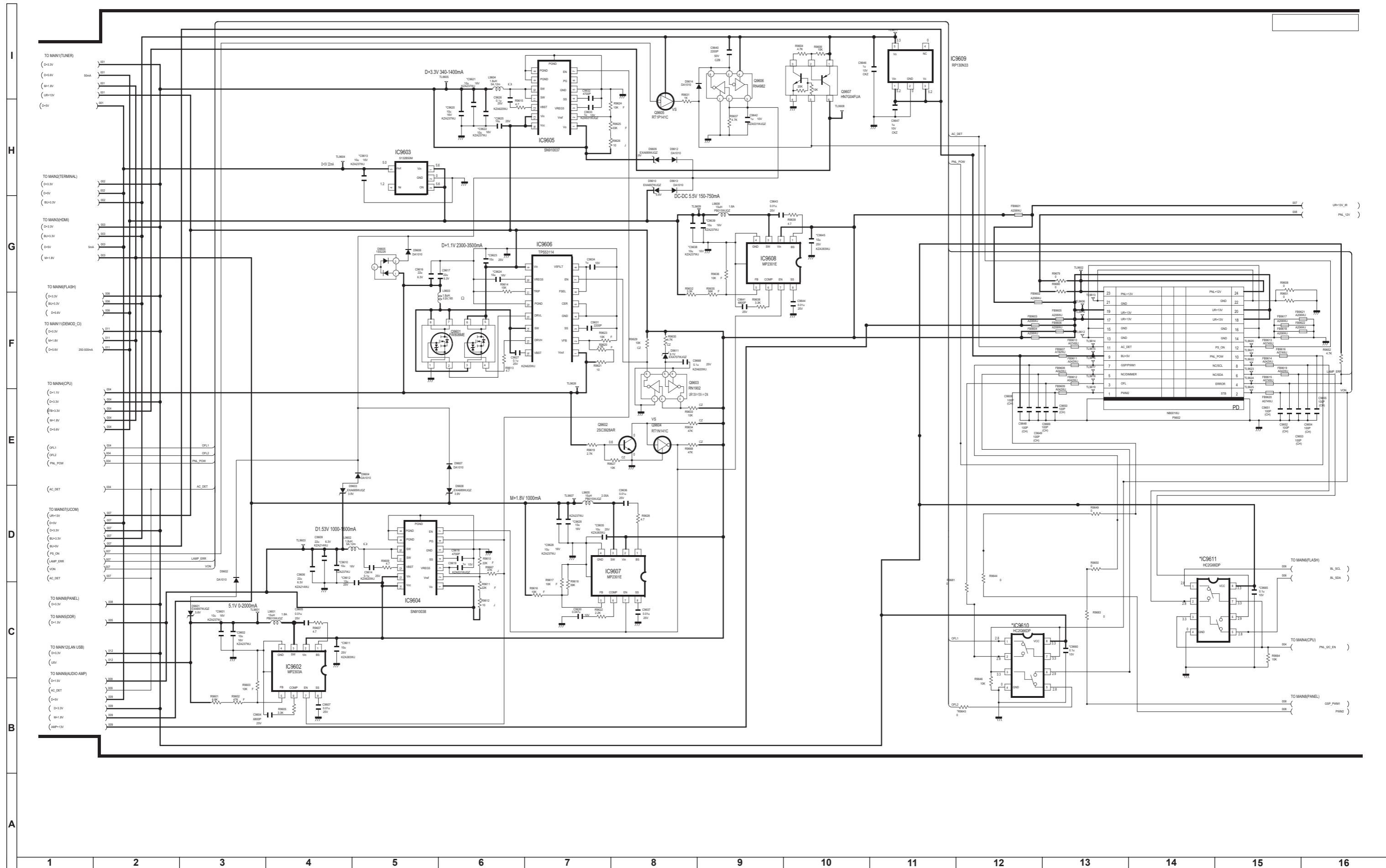

Main Unit Diagram DUNTKF733WE 12/12 (LAN_USB)

I
H
G
F
E
D
C
B
A

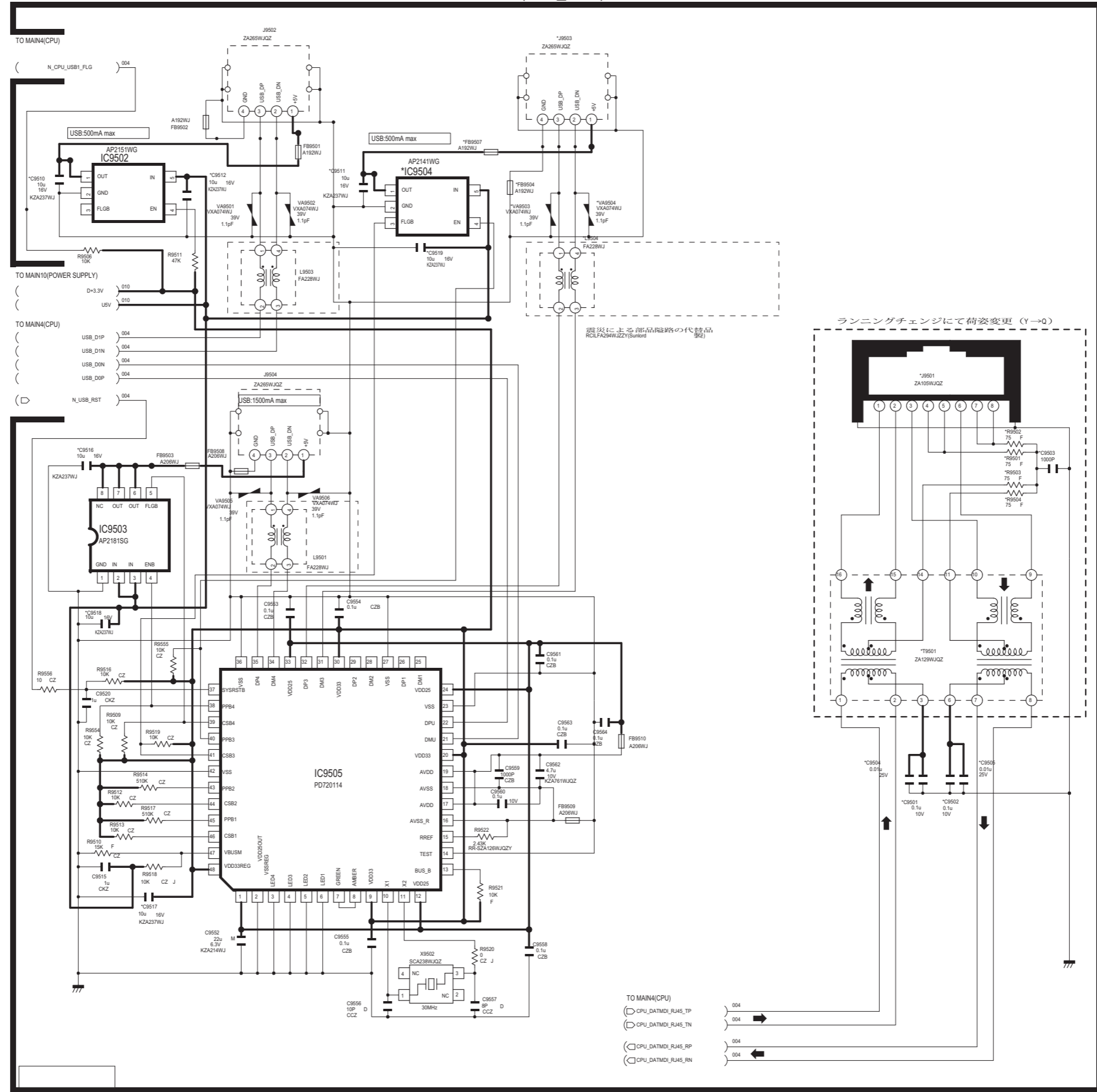

ランニングチェンジにて荷姿変更 (Y→Q)

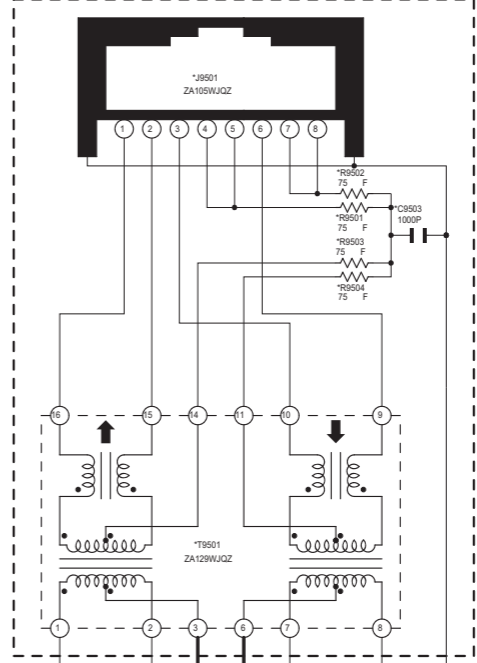

TO MAIN4(CPU)
 (▷) CPU_DATMDI_R445_TP
 (◁) CPU_DATMDI_R445_TN
 (◁) CPU_DATMDI_R445_RP
 (▷) CPU_DATMDI_R445_RN

1 2 3 4 5 6 7 8 9 10 11 12 13 14 15 16

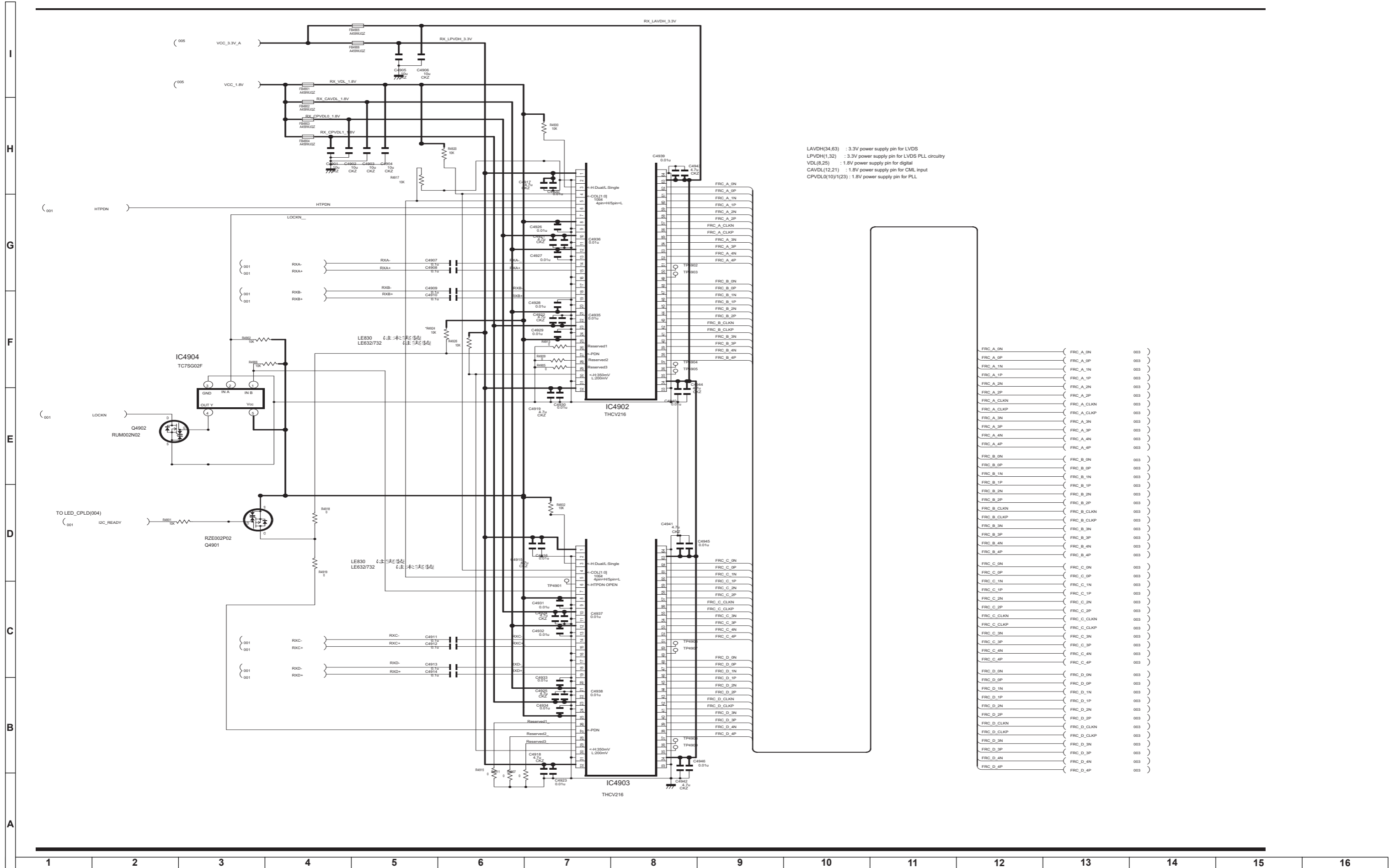

LAVDH(34.63) : 3.3V power supply pin for LVDS
LPVDH(1.32) : 3.3V power supply pin for LVDS PLL circuitry
VLDH(8.25) : 1.8V power supply pin for digital
CAVDL(12.21) : 1.8V power supply pin for CML input
CPVDL(10)(1/23) : 1.8V power supply pin for PLL

FRC_A_0N	FRC_A_0N	003
FRC_A_0P	FRC_A_0P	003
FRC_A_1N	FRC_A_1N	003
FRC_A_1P	FRC_A_1P	003
FRC_A_2N	FRC_A_2N	003
FRC_A_2P	FRC_A_2P	003
FRC_A_CLKN	FRC_A_CLKN	003
FRC_A_CLKP	FRC_A_CLKP	003
FRC_A_3N	FRC_A_3N	003
FRC_A_3P	FRC_A_3P	003
FRC_A_4N	FRC_A_4N	003
FRC_A_4P	FRC_A_4P	003
FRC_B_0N	FRC_B_0N	003
FRC_B_0P	FRC_B_0P	003
FRC_B_1N	FRC_B_1N	003
FRC_B_1P	FRC_B_1P	003
FRC_B_2N	FRC_B_2N	003
FRC_B_2P	FRC_B_2P	003
FRC_B_CLKN	FRC_B_CLKN	003
FRC_B_CLKP	FRC_B_CLKP	003
FRC_B_3N	FRC_B_3N	003
FRC_B_3P	FRC_B_3P	003
FRC_B_4N	FRC_B_4N	003
FRC_B_4P	FRC_B_4P	003
FRC_C_0N	FRC_C_0N	003
FRC_C_0P	FRC_C_0P	003
FRC_C_1N	FRC_C_1N	003
FRC_C_1P	FRC_C_1P	003
FRC_C_2N	FRC_C_2N	003
FRC_C_2P	FRC_C_2P	003
FRC_C_CLKN	FRC_C_CLKN	003
FRC_C_CLKP	FRC_C_CLKP	003
FRC_C_3N	FRC_C_3N	003
FRC_C_3P	FRC_C_3P	003
FRC_C_4N	FRC_C_4N	003
FRC_C_4P	FRC_C_4P	003
FRC_D_0N	FRC_D_0N	003
FRC_D_0P	FRC_D_0P	003
FRC_D_1N	FRC_D_1N	003
FRC_D_1P	FRC_D_1P	003
FRC_D_2N	FRC_D_2N	003
FRC_D_2P	FRC_D_2P	003
FRC_D_CLKN	FRC_D_CLKN	003
FRC_D_CLKP	FRC_D_CLKP	003
FRC_D_3N	FRC_D_3N	003
FRC_D_3P	FRC_D_3P	003
FRC_D_4N	FRC_D_4N	003
FRC_D_4P	FRC_D_4P	003

LCD Controller Unit Diagram RUNTK4910TPZT 3 / 6 (CLOVER)

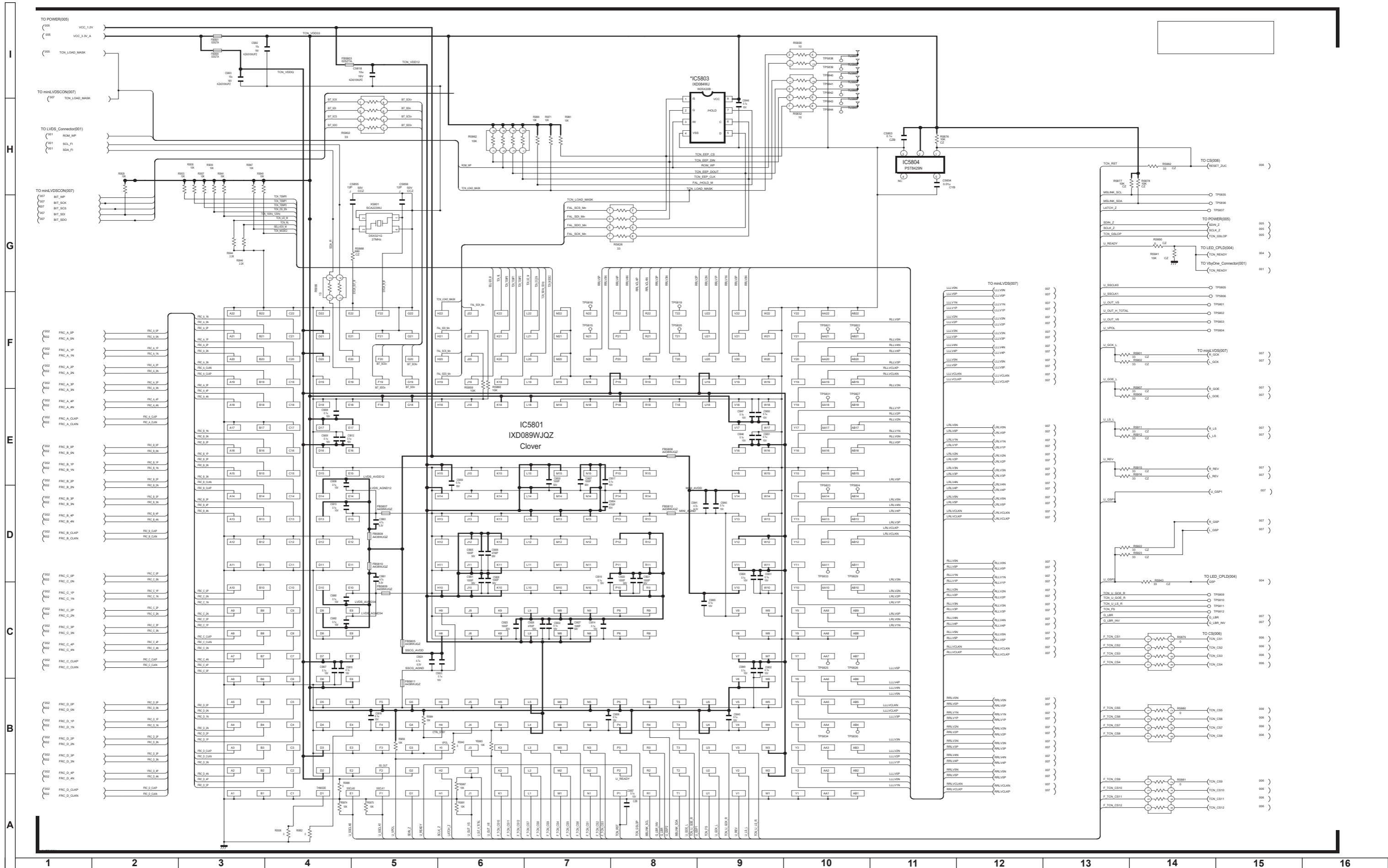

LCD Controller Unit Diagram RUNTK4910TPZT 4 / 6 (POWER)

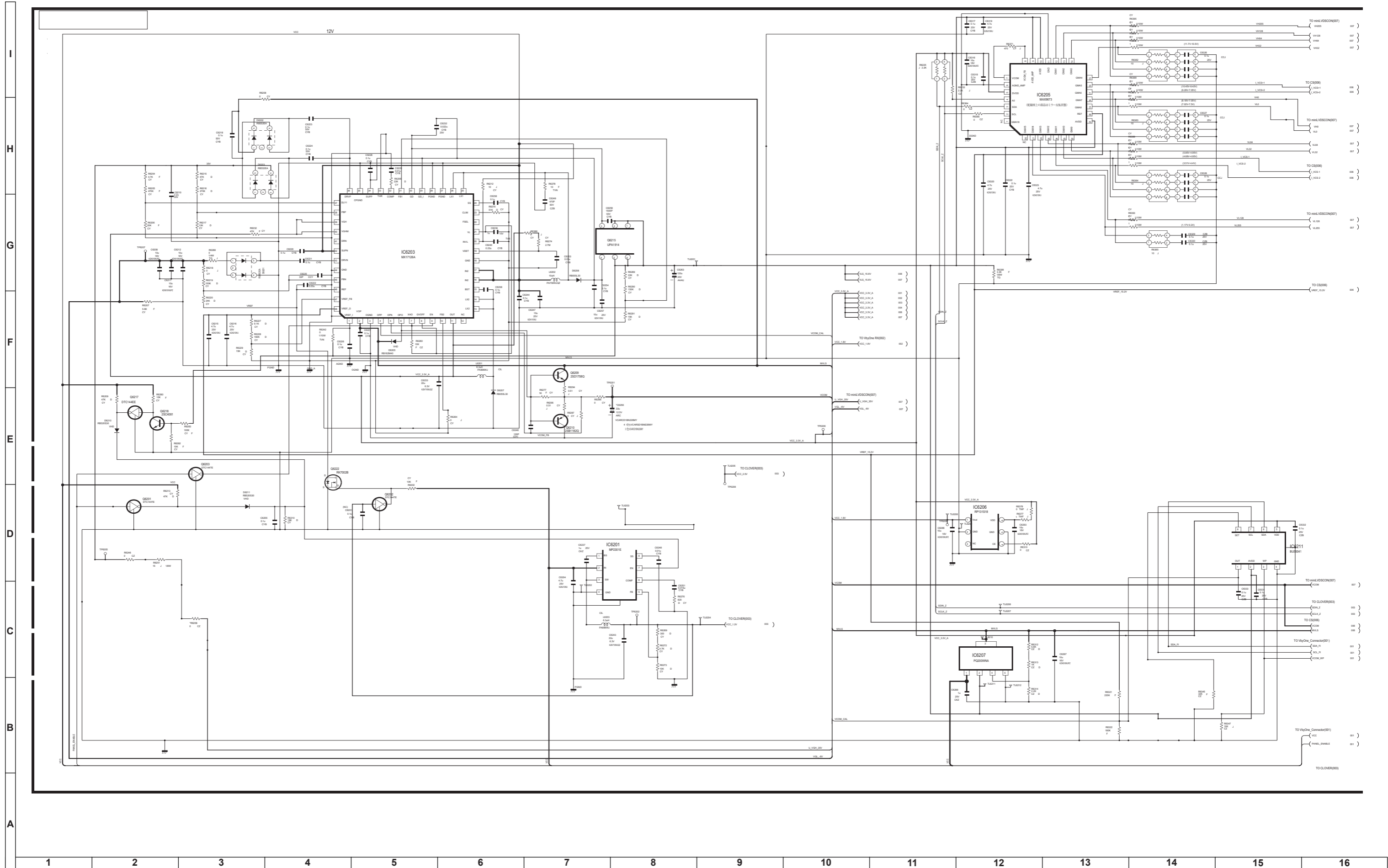

LCD Controller Unit Diagram RUNTK4910TPZT 5 / 6 (CS)

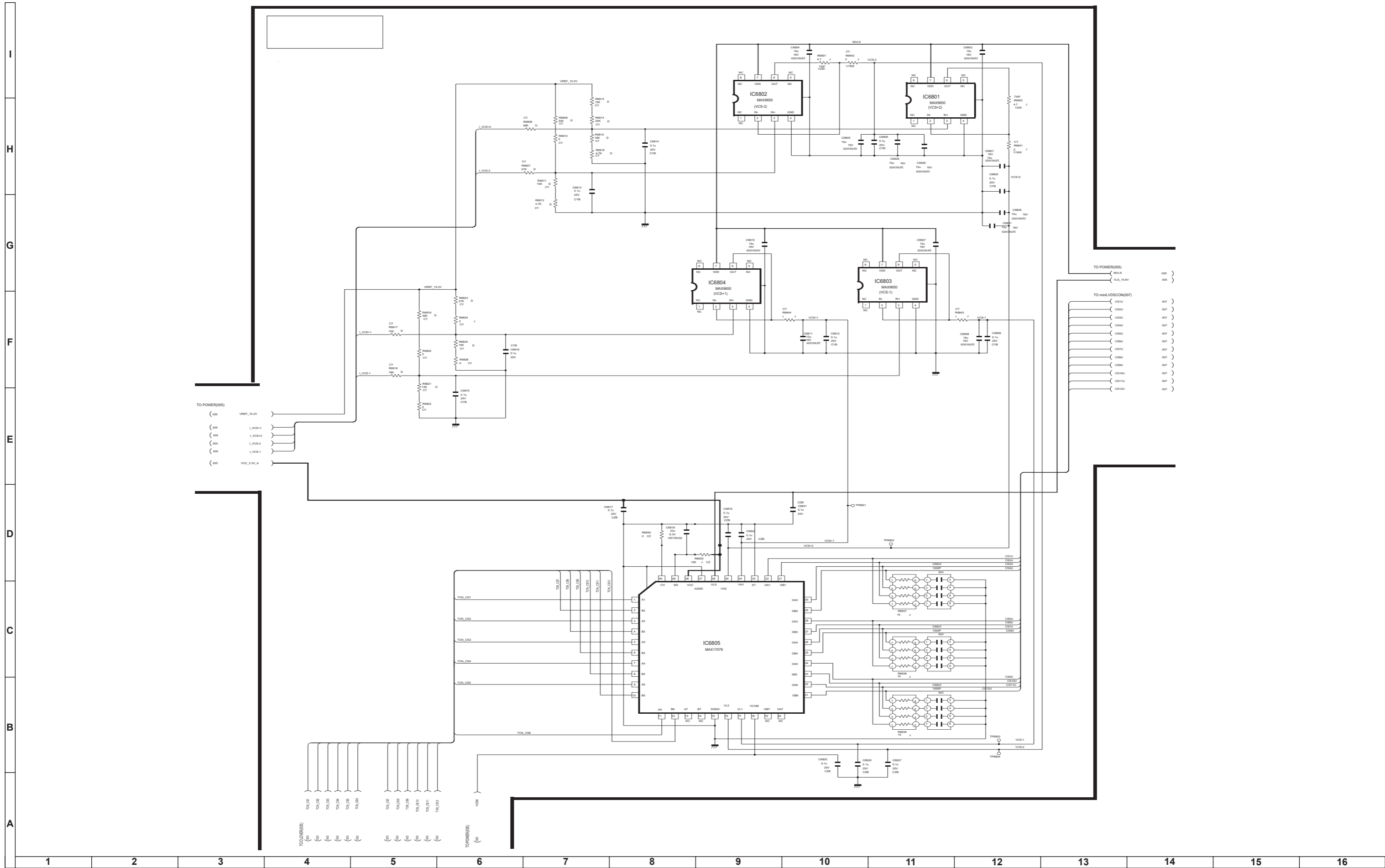

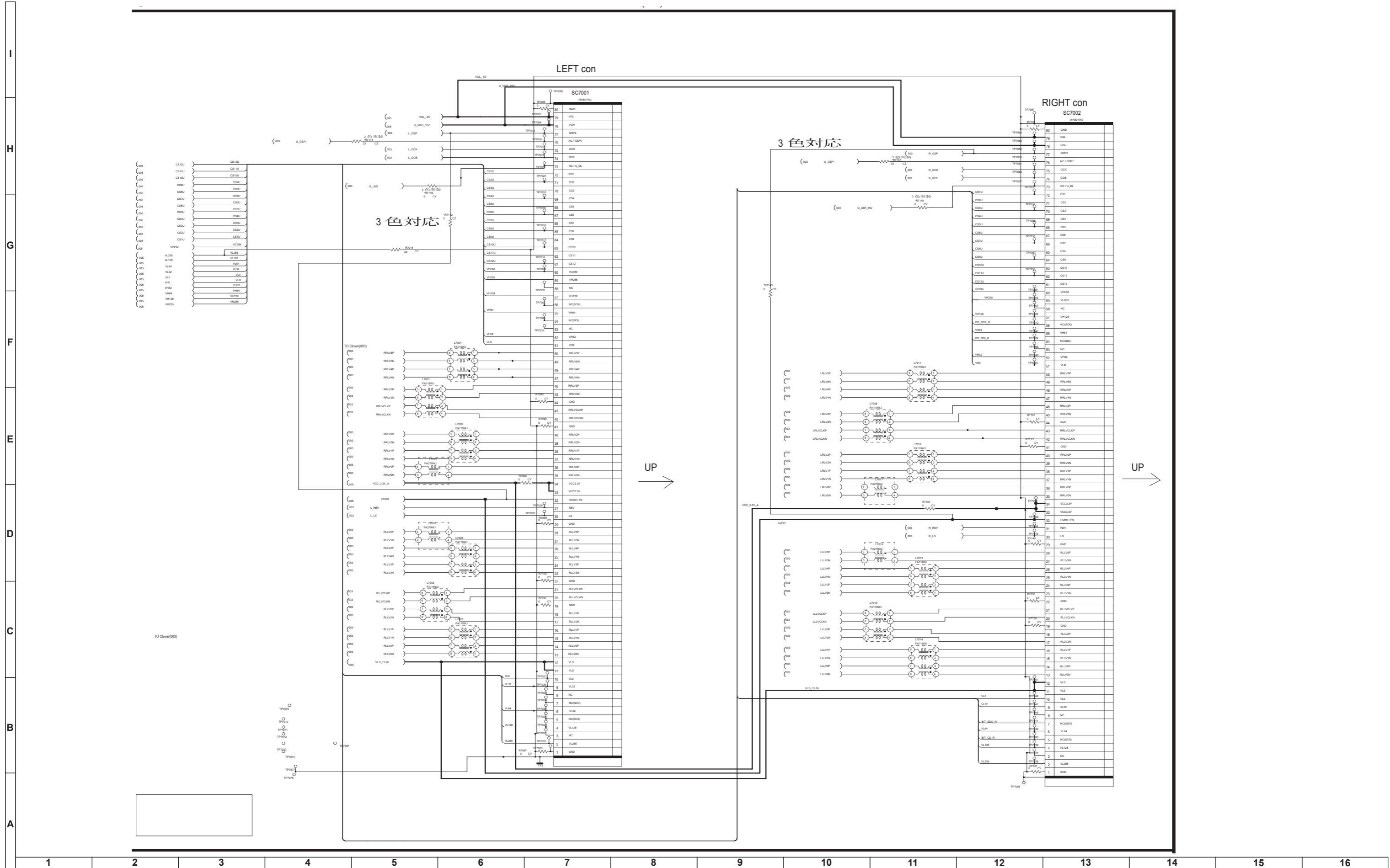

Power Unit Diagram

RUNTKA847WJN1 (1 / 3)

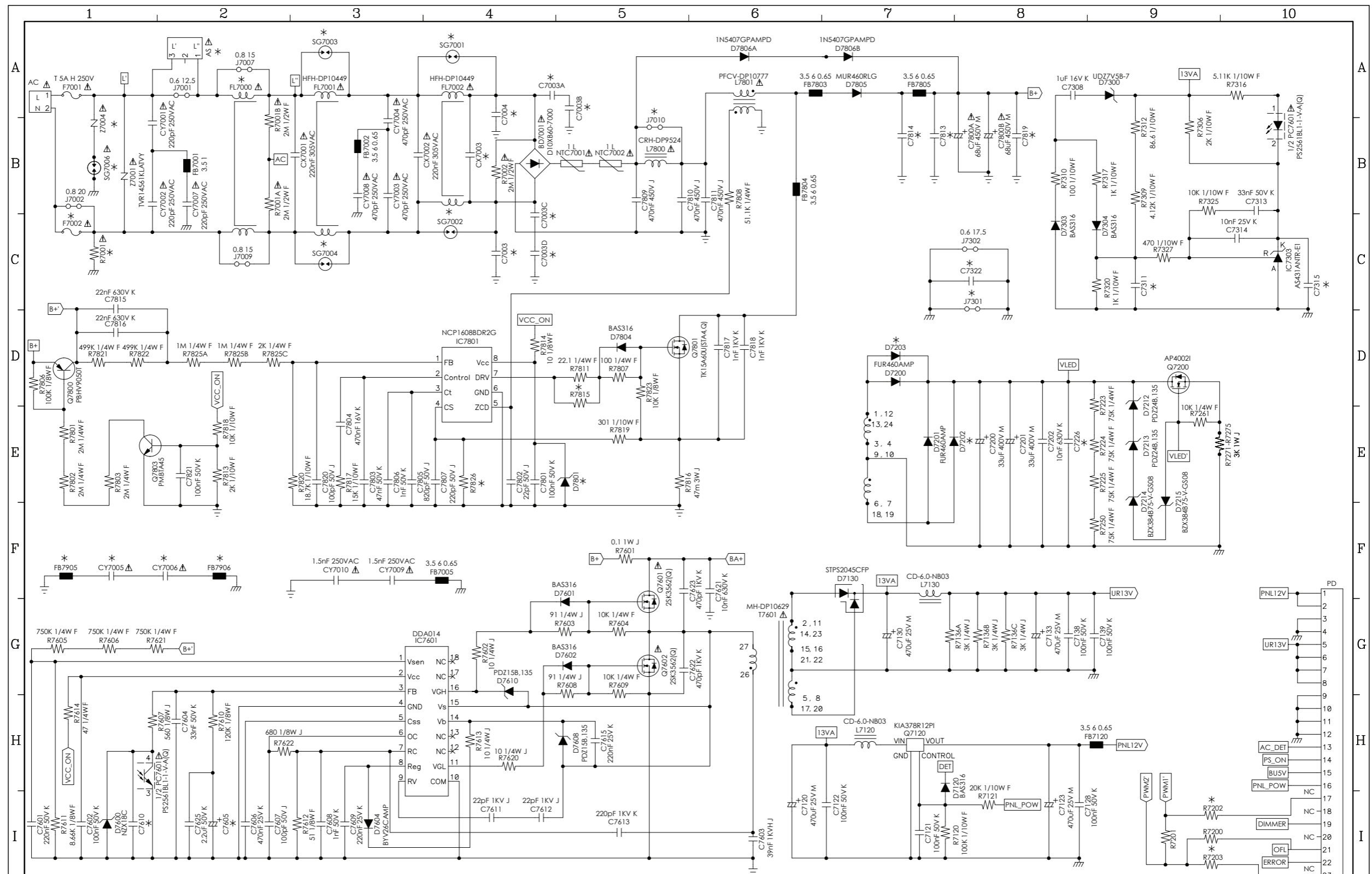

*:NO COMPONENTS

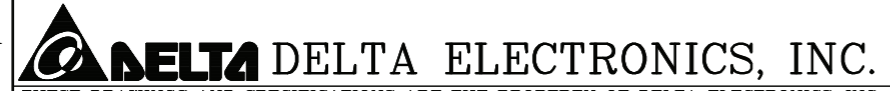

THESE DRAWINGS AND SPECIFICATIONS ARE THE PROPERTY OF DELTA ELECTRONICS, INC. AND SHALL NOT BE REPRODUCED OR USED AS THE BASIS FOR THE MANUFACTURE OR SELL OF APPARATUS OR DEVICES WITHOUT PERMISSION.

Date:06/20/11'	LY.REV: 0	Drawn:EASON	Checked	Approved	MODEL NAME	REV.	SHEET
PWB: D165HP2ROCO	FILE NAME:D165HP2RO				RUNTKA847WJN1		01 OF 03
DESCRIPTION:SCHEMATIC OF SWITCHING POWER SUPPLY					DPS-165HP-2 A		

Frame Name:DF-SCA2H-1R00.SCH

Power Unit Diagram

RUNTKA847WJN1 (2 / 3)

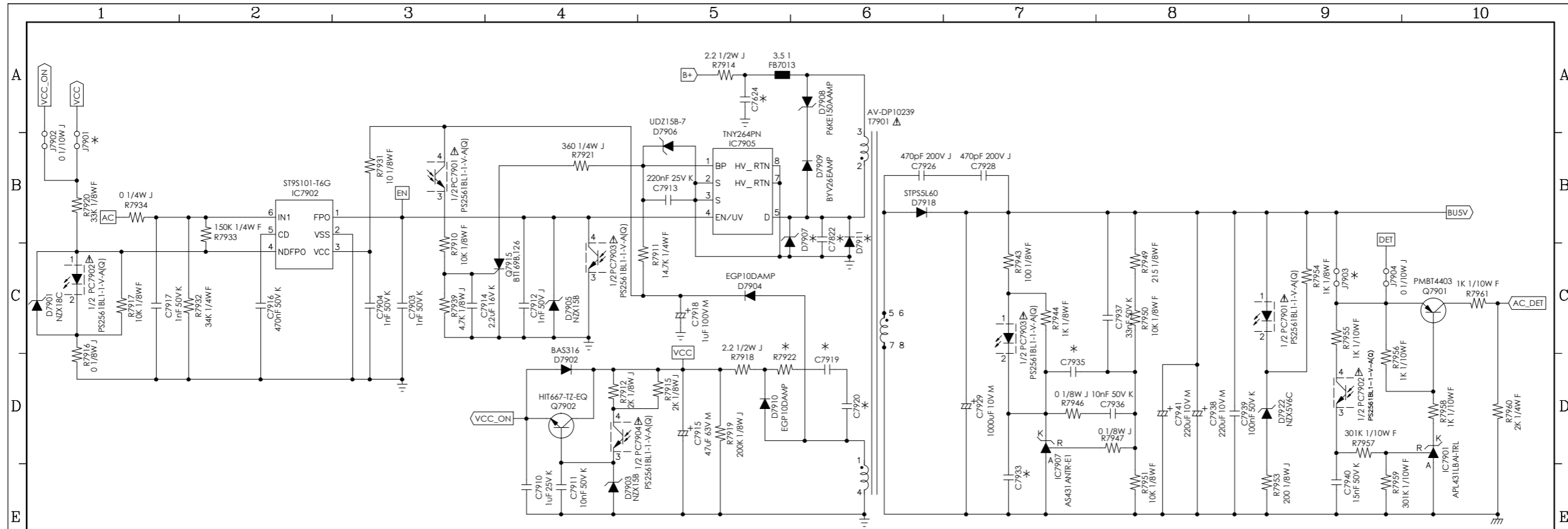

Power Table			
RefDes	UR13.2V*	SGND	UR13V**
IC7283	8	4	
IC7381		2	5

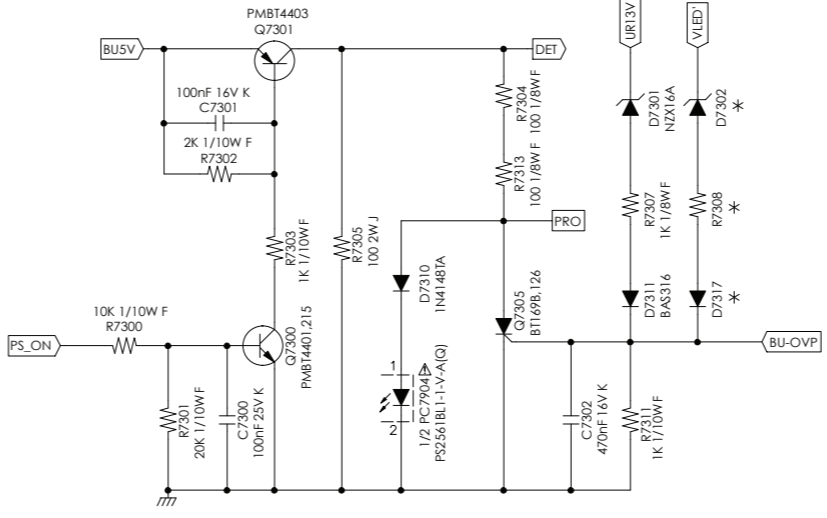
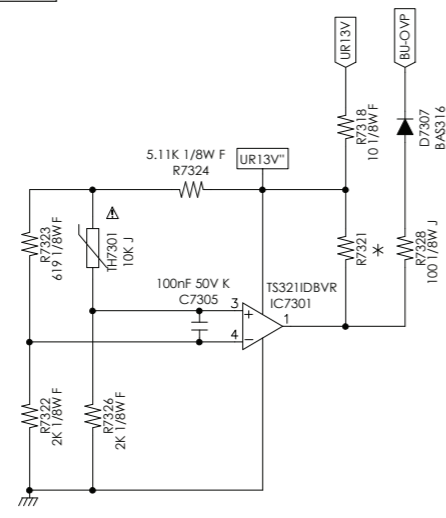

*:NO COMPONENTS

DELTA DELTA ELECTRONICS, INC.
 THESE DRAWINGS AND SPECIFICATIONS ARE THE PROPERTY OF DELTA ELECTRONICS, INC. AND SHALL NOT BE REPRODUCED OR USED AS THE BASIS FOR THE MANUFACTURE OR SELL OF APPARATUS OR DEVICES WITHOUT PERMISSION.

Date:06/20/11'	LY.REV: 0	Drawn:EASON	Checked	Approved
PWB:D165HP2R0C0	FILE NAME:D165HP2R0	DESCRIPTION:SCHEMATIC OF SWITCHING POWER SUPPLY		

MODEL NAME	REV.	SHEET
RUNTKA847WJN1 DPS-165HP-2 A		02 OF 03

Frame Name:DF-SCA2H-1R00.SCH

Power Unit Diagram

RUNTKA847WJN1 (3 / 3)

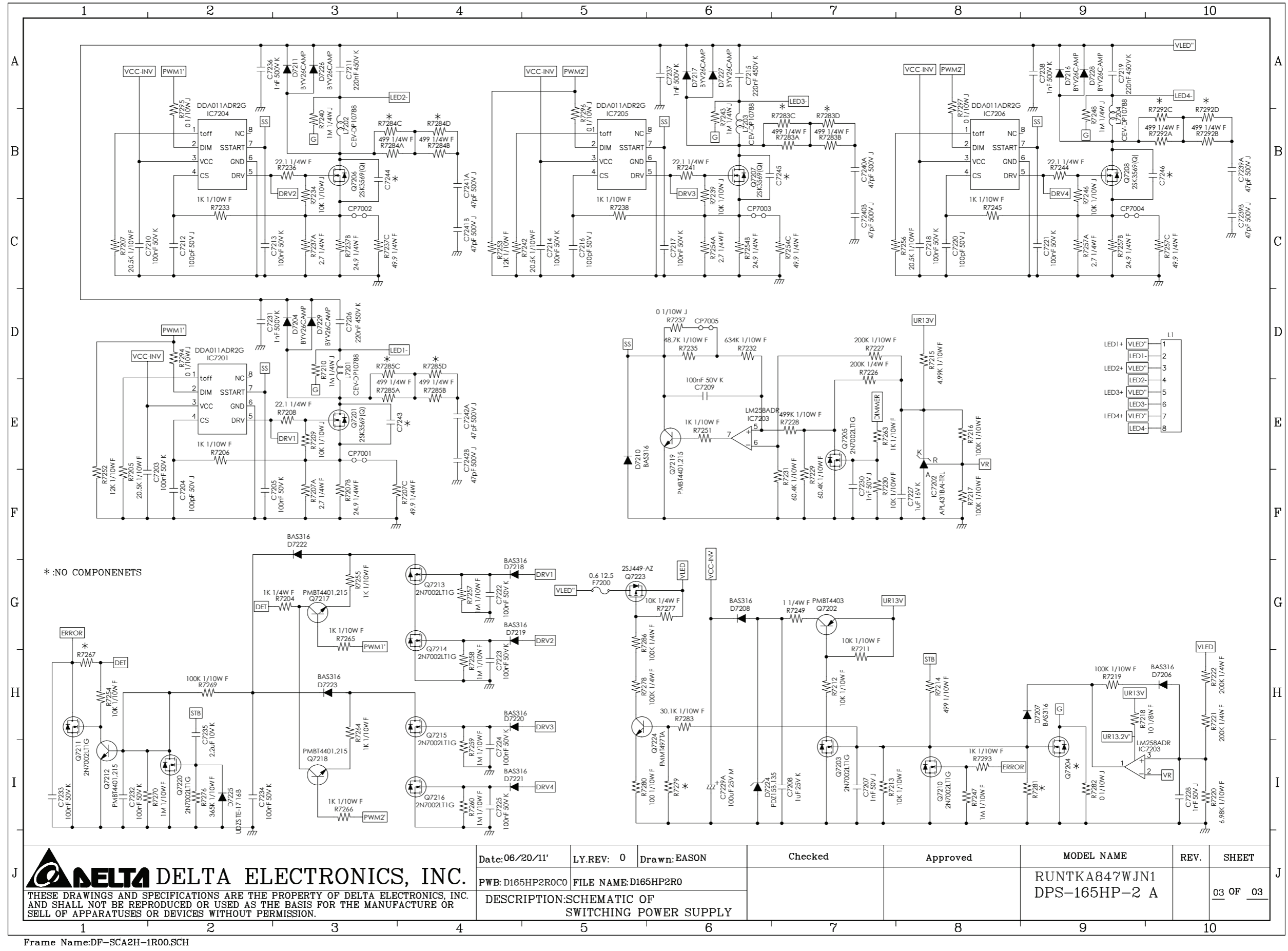

DELTA DELTA ELECTRONICS, INC.
THESE DRAWINGS AND SPECIFICATIONS ARE THE PROPERTY OF DELTA ELECTRONICS, INC. AND SHALL NOT BE REPRODUCED OR USED AS THE BASIS FOR THE MANUFACTURE OR SELL OF APPARATUS OR DEVICES WITHOUT PERMISSION.

Date:06/20/11'	LY.REV: 0	Drawn:EASON	Checked	Approved	MODEL NAME	REV.	SHEET
PWB:D165HP2ROCO		FILE NAME:D165HP2RO			RUNTKA847WJN1		03 OF 03
DESCRIPTION:SCHEMATIC OF SWITCHING POWER SUPPLY					DPS-165HP-2 A		

Frame Name:DF-SCA2H-1R00.SCH

PRINTED WIRING BOARD

Main Unit PWB (QPWBXF733WJN2)
Side A

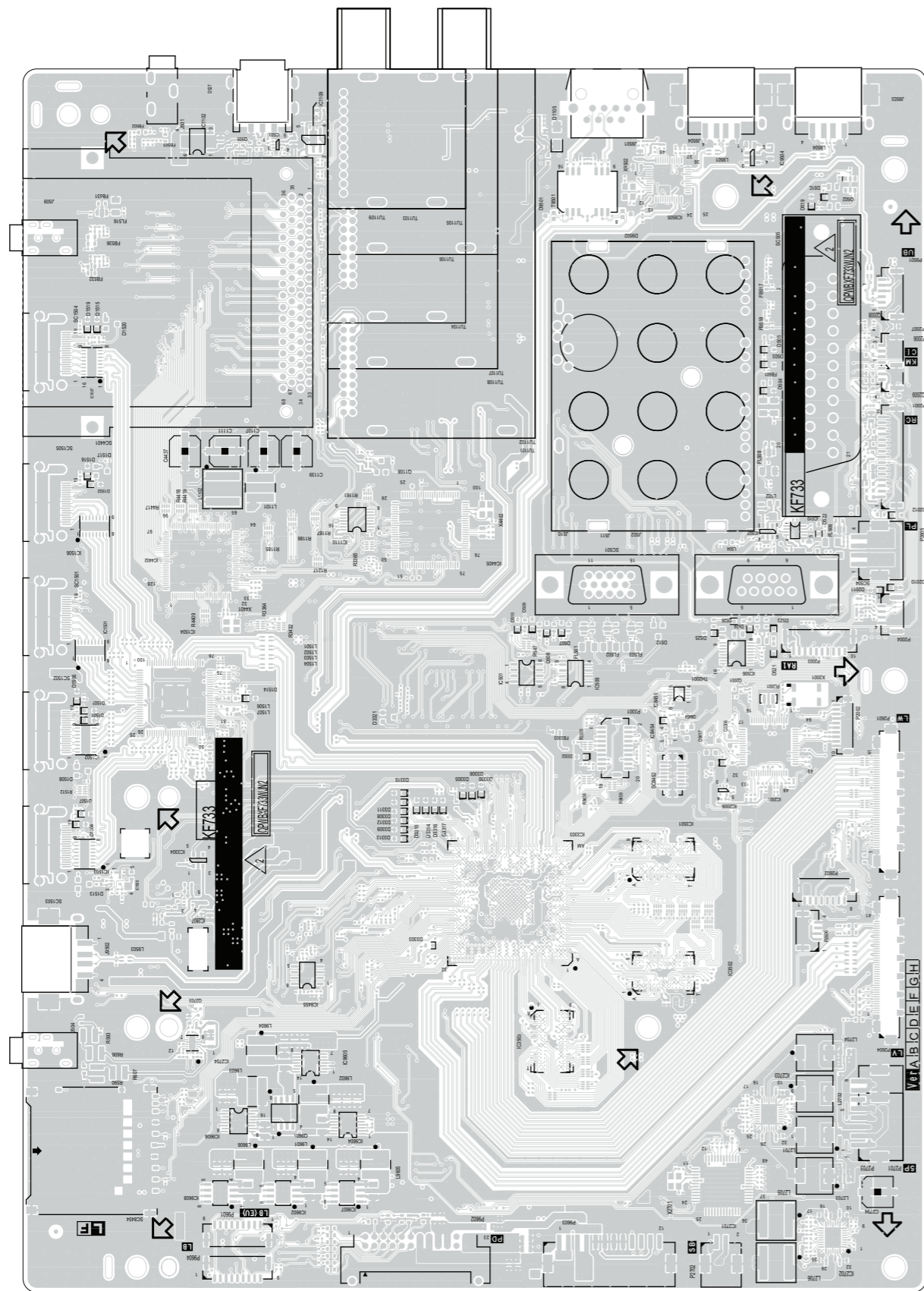

Side A Chip Parts

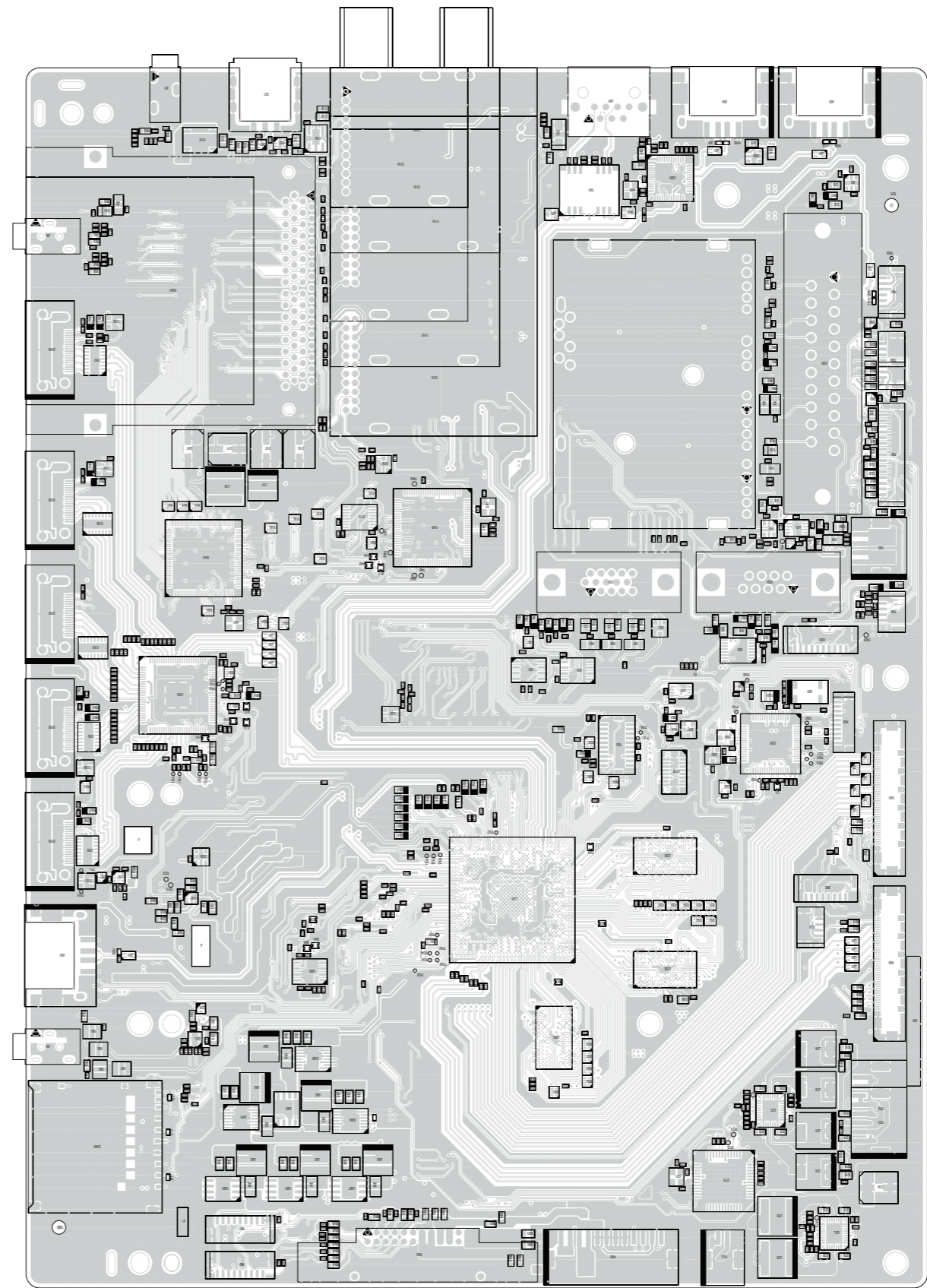

Main Unit PWB (QPWBXF733WJN2)

Side B

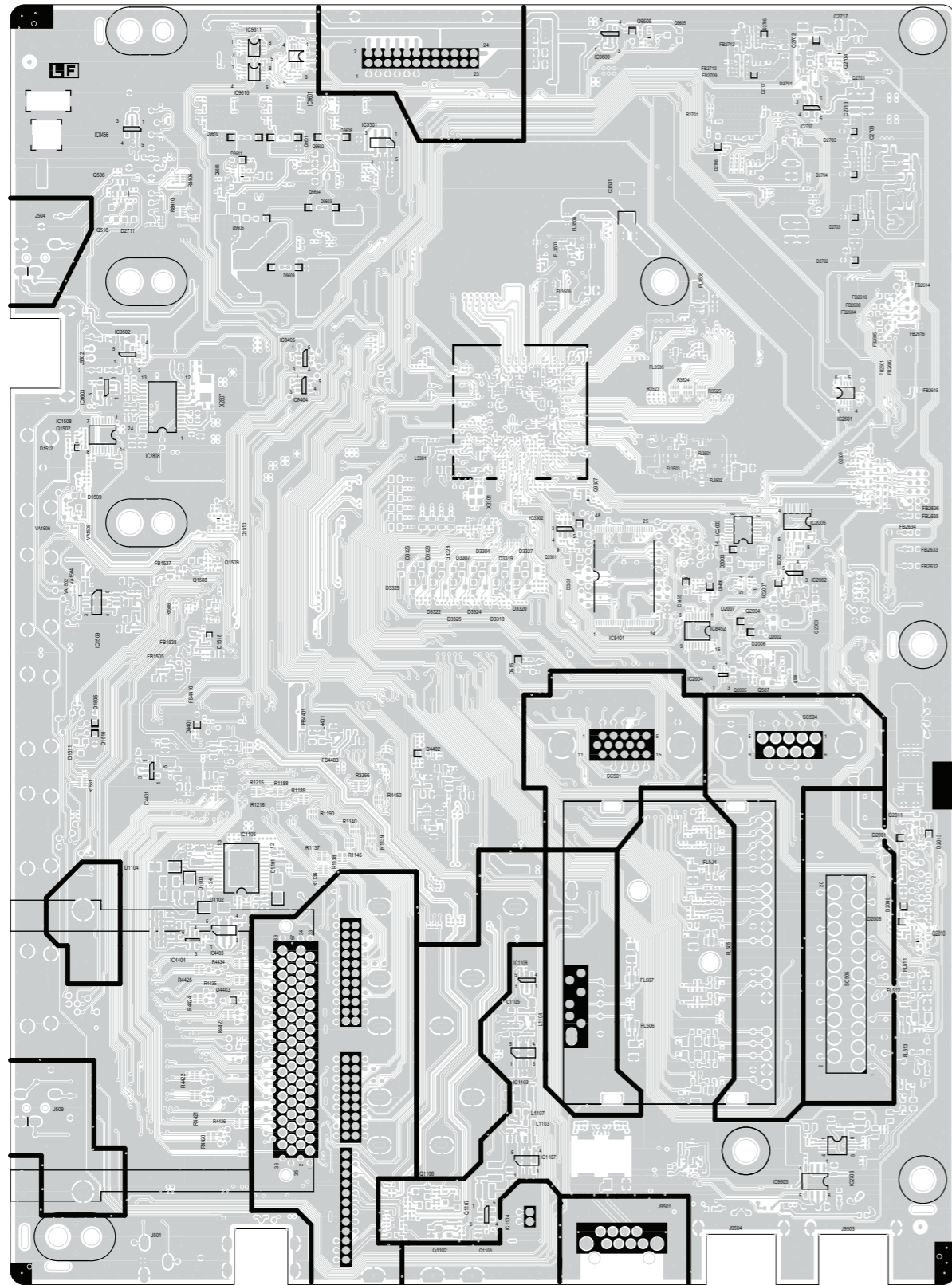

Side B Chip Parts

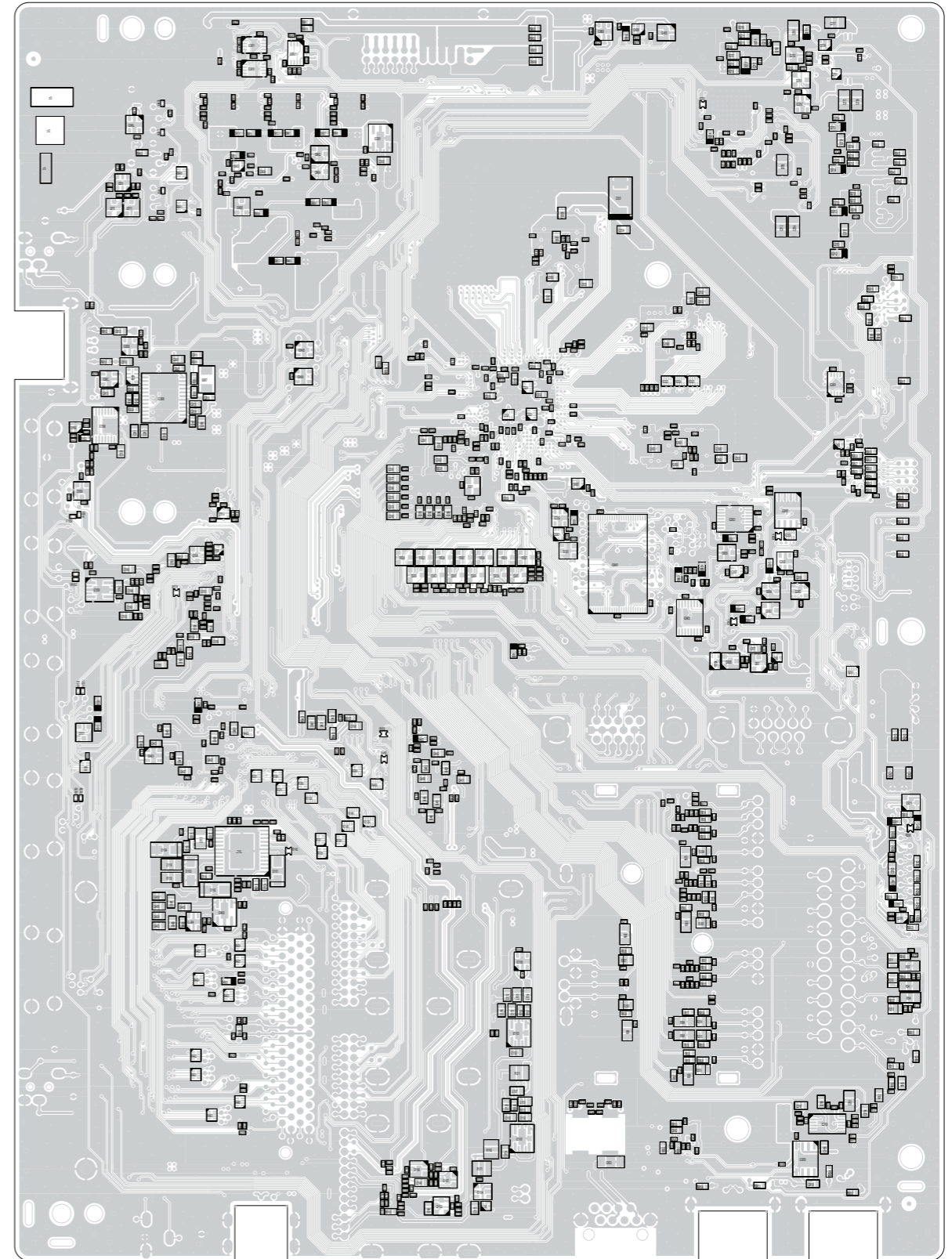

Power Unit PWB RUNTKA847WJN1

Power Unit, Side A

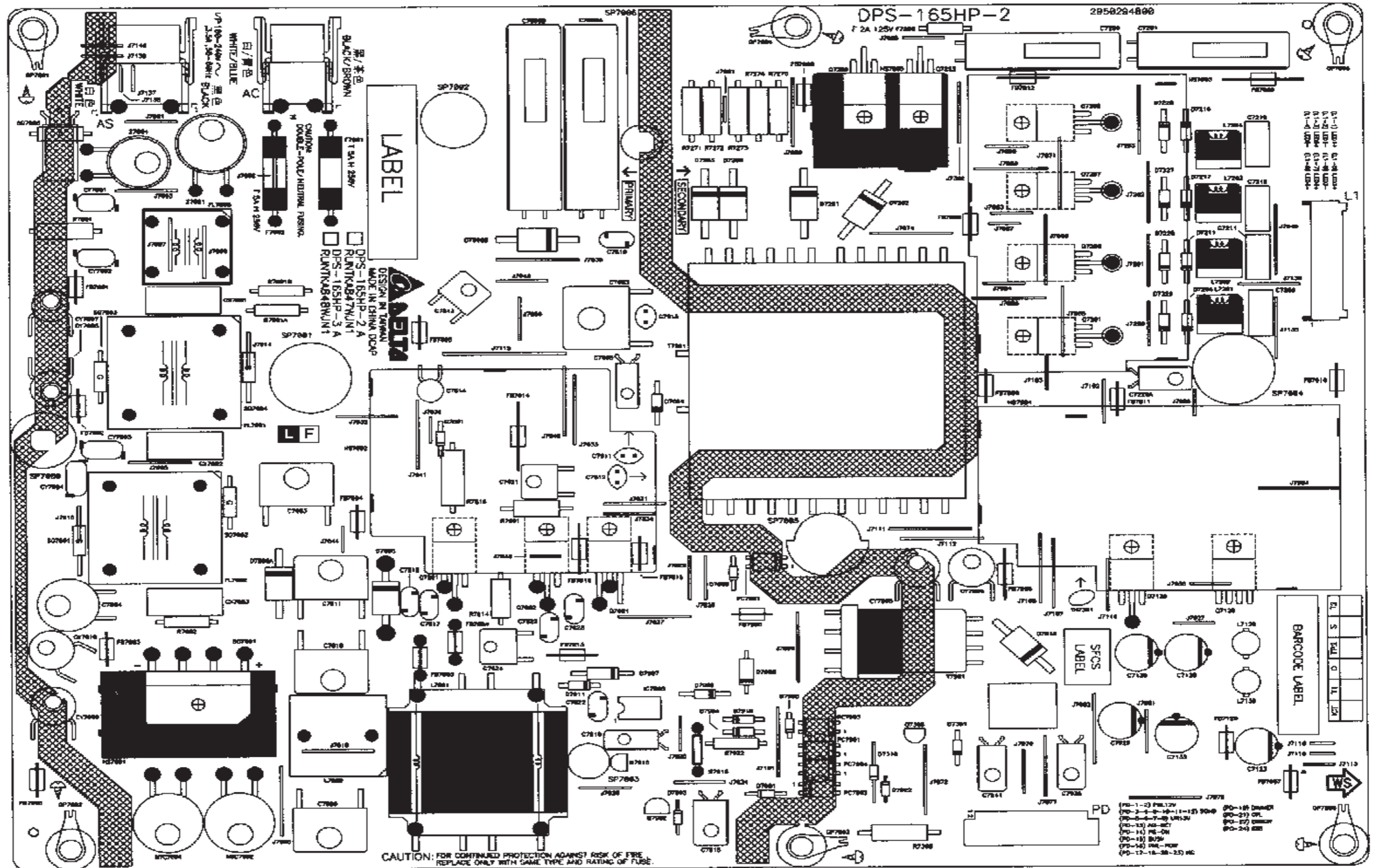

Power Unit PWB

RUNTKA847WJN1

Power Unit, Side B

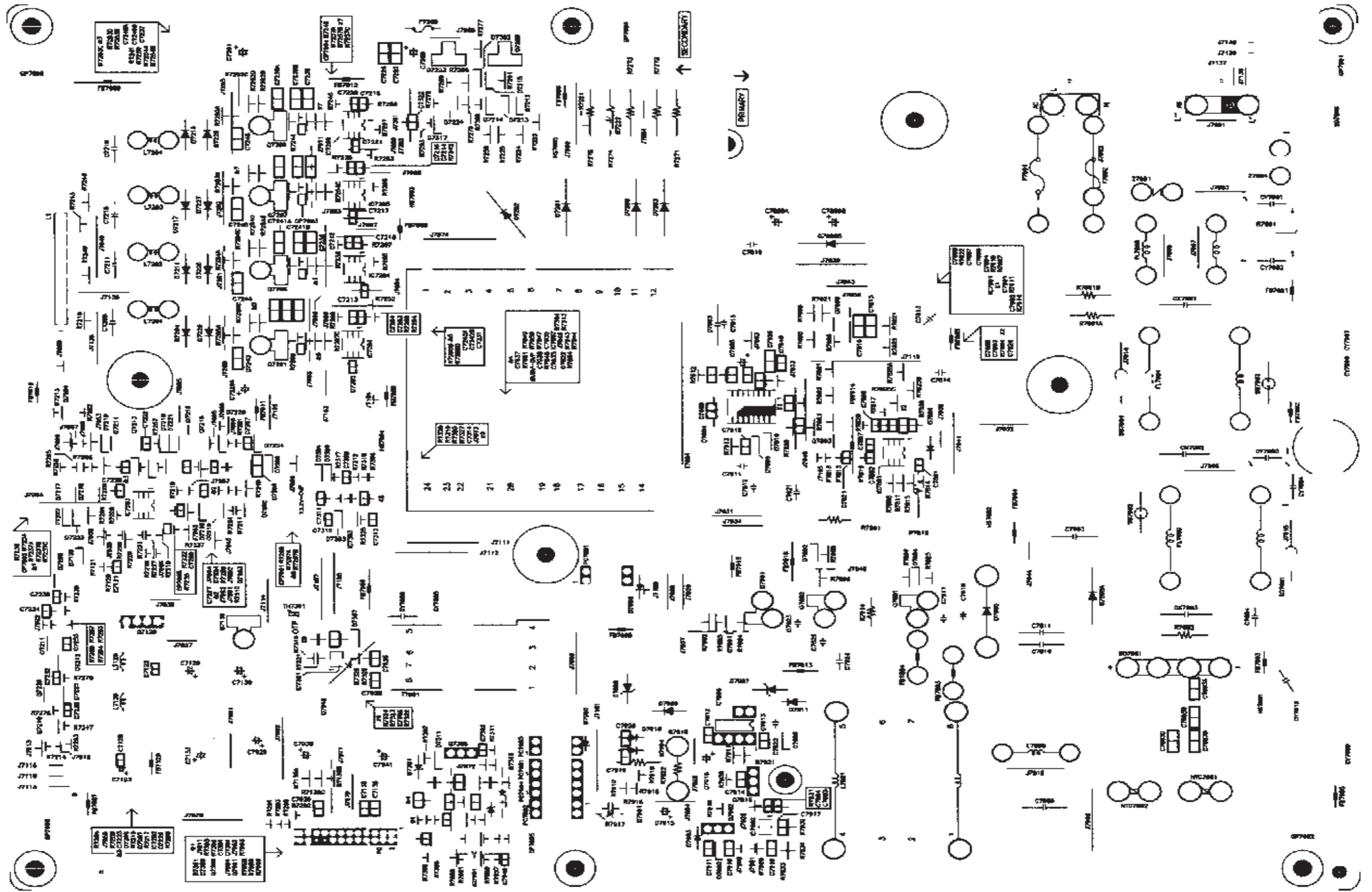

NOTES:

RC Unit PWB (QPWBNF494WJZZ)

Side A

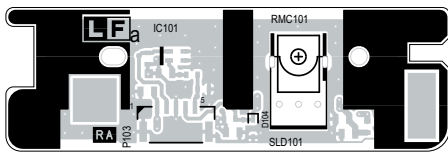

Side b

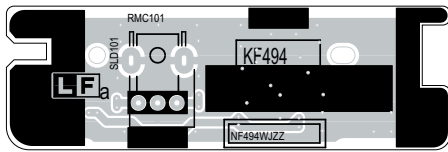

Icon Unit PWB (QPWBNF770WJZZ)

Side A

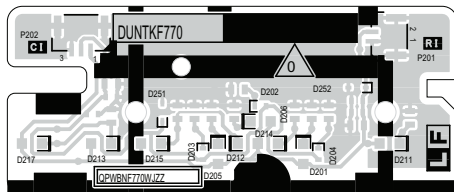

Side A Chip Parts

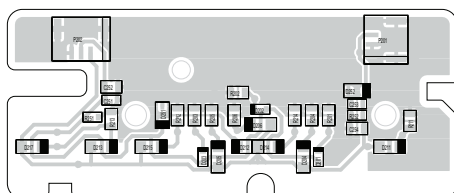

I
H
G
F
E
D
C
B
A

1 2 3 4 5 6 7

SHARP®

COPYRIGHT © 2011 BY SHARP CORPORATION

ALL RIGHTS RESERVED

No part of this publication may be reproduced, stored in a retrieval system, or transmitted in any form or by any means, electronic, mechanical, photocopying, recording, or otherwise, without prior written permission of the publisher.

SHARP CORPORATION
AV System Group

SHARP ELECTRONICA ESPAÑA S.A.
Service Manual Group
Engineering Dept.
C/ Sena, 2-10
08174 Sant Cugat del Vallès
Barcelona
Spain