



# MANUEL SAV - SAV MANUAL



SEB INTERNATIONAL SERVICE



# KRUPS

# Table of contents

1	General data .....	3
2	Technical data .....	3
2.1	Reference value: .....	3
3	Hydraulic and wiring diagrams .....	4
3.1	Wiring diagram : .....	4
3.2	Hydraulic diagram: .....	5
4	Dismantling.....	6
4.1	General dismantling .....	6
4.2	Grinder .....	10
4.3	Subassembly switch ejection .....	13
4.4	Switch ejection disassembly.....	16
5	ASS Mode .....	19
5.1	ASS mode 1 : .....	19
5.2	Scrolling ASS data : .....	19
5.3	View ASS data : .....	20
5.4	Ass Data description:.....	21
6	Process of calibration .....	23
6.1	Parts concerned : .....	23
6.2	Access to calibration program:.....	23
6.3	Calibration Cycle : .....	23
7	ASS Defect description .....	24

# 1 General data

Pisa				
	EA8150	EA8155	EA815B	EA815E
				
				
	EA8161	EA8165	EA816B	

# 2 Technical data

## 2.1 Reference value:

- Espresso temperature (50ml – strong coffee) 1st coffee : 68°C mini
- Temperature increase by steam with 125ml of water after 45s : 42°C
- Cake thickness : 12-14mm

# 3 Hydraulic and wiring diagrams

## 3.1 Wiring diagram :

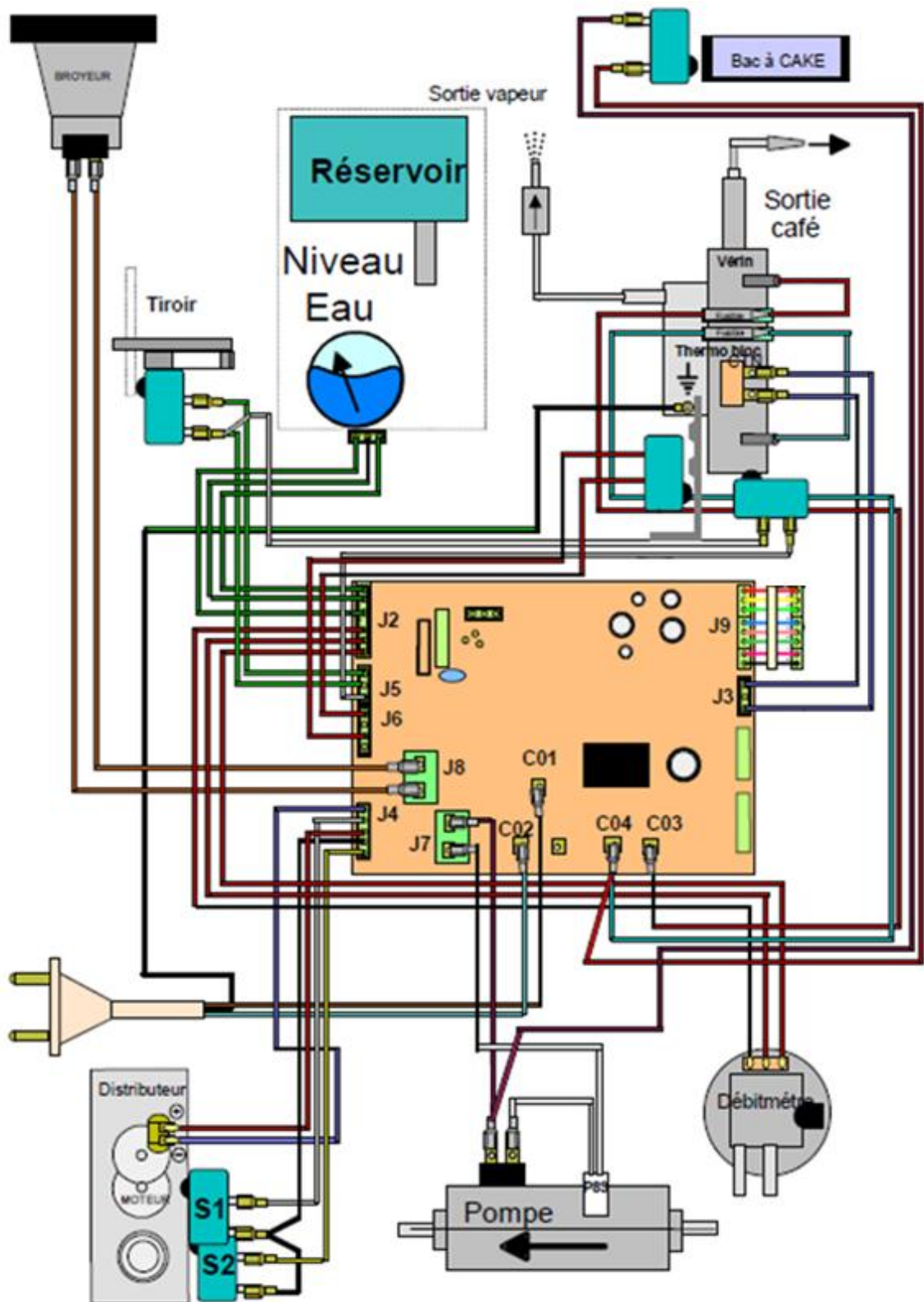

### 3.2 Hydraulic diagram:

**Position (0)**  
Jack draining  
Steam draining

**Position (1)**  
Steam + hot water

**Position (2)**  
Jack supply

**Position (3)**  
Coffee

**Position (4)**  
Coffee draining

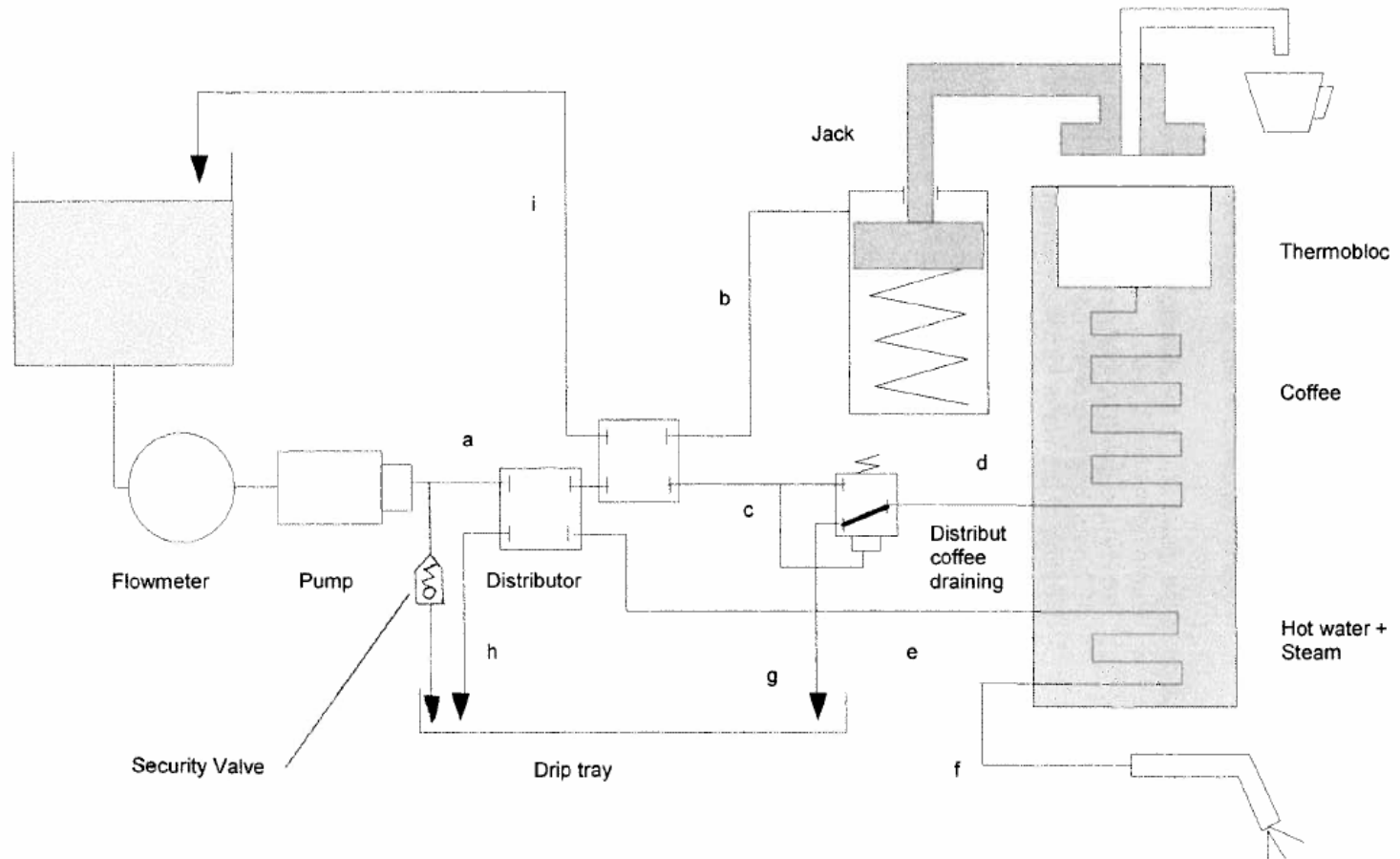
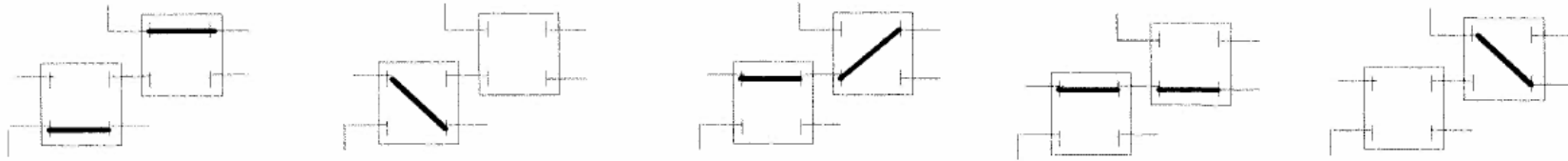

# 4 Dismantling

## 4.1 General dismantling

Tools: Torx screwdriver (T15 & T10)

Unscrews the 4 screws of the front



Unscrew the screws from the coffee bean container

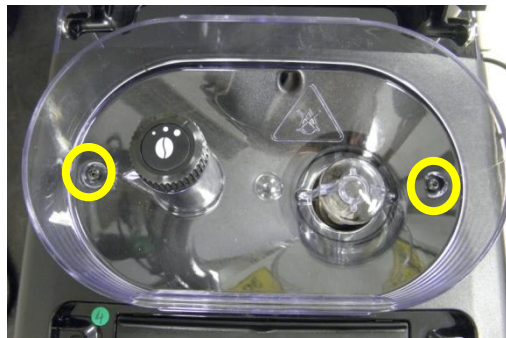

Unscrew the 3 screws from the cover of top and the screw of the cleaning tablet pipe

Remove the cover by pulling upward with your hand in place of cleaning tablet pipe

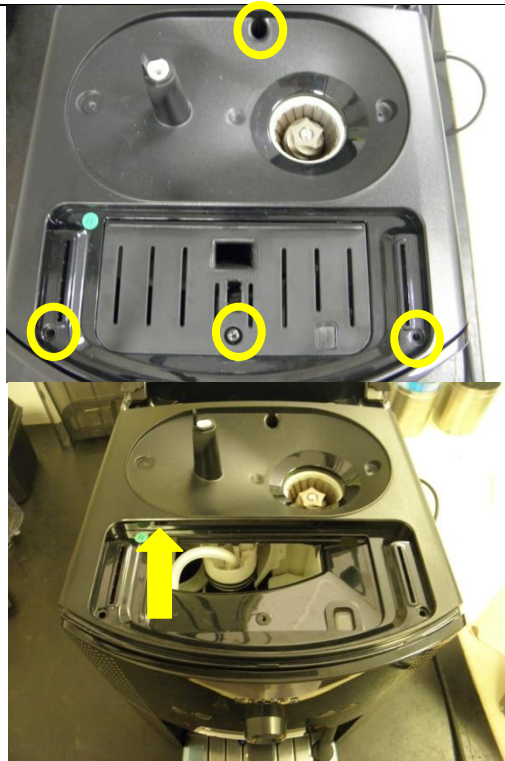

Unscrew the 2 screws of from the rear. Draw a sharp blow to dislodge this parts

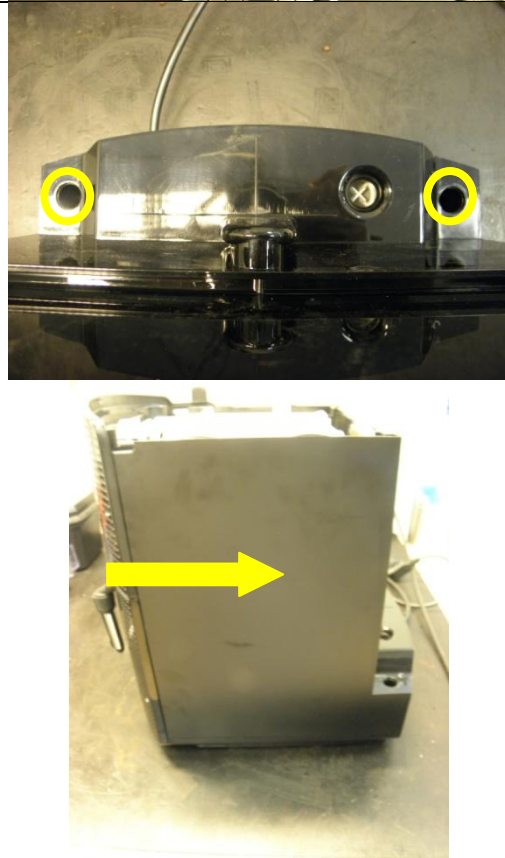

Unclip the electronic interface (2 clips on each side)

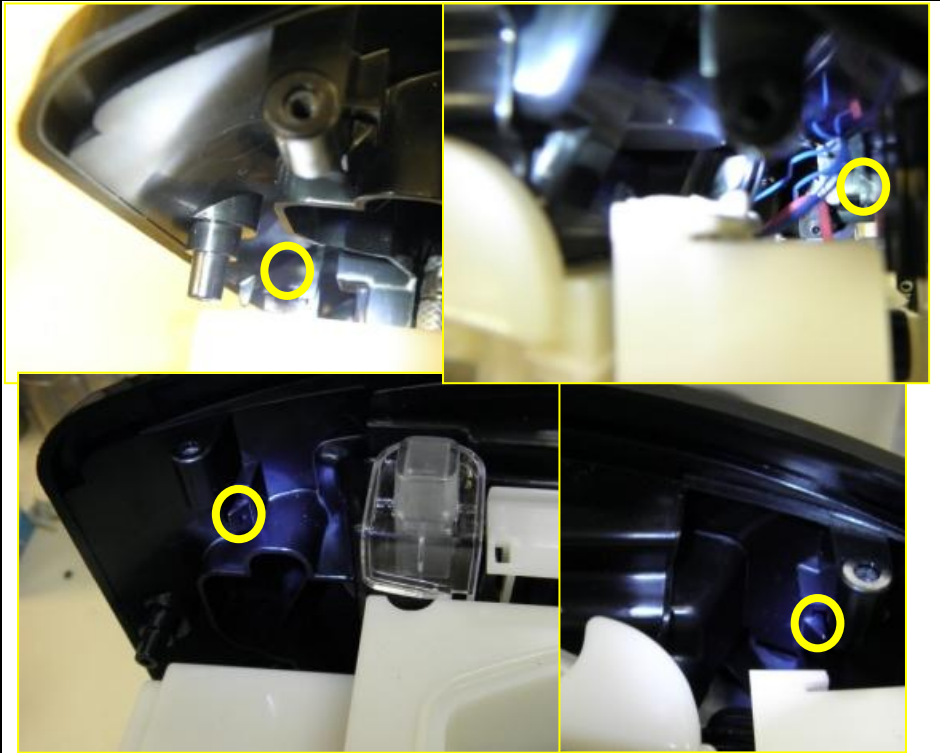

Disconnect the electronic interface



Take away the coffee pipe

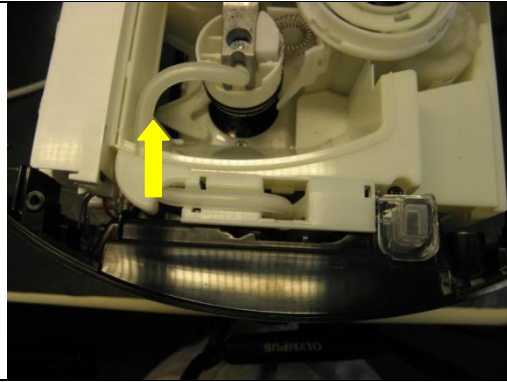

Unscrew the 2 screws in the bottom and the 2 screws in the top

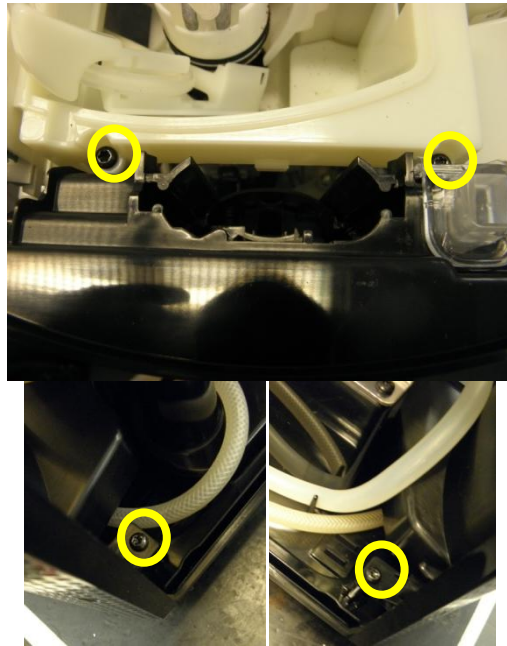



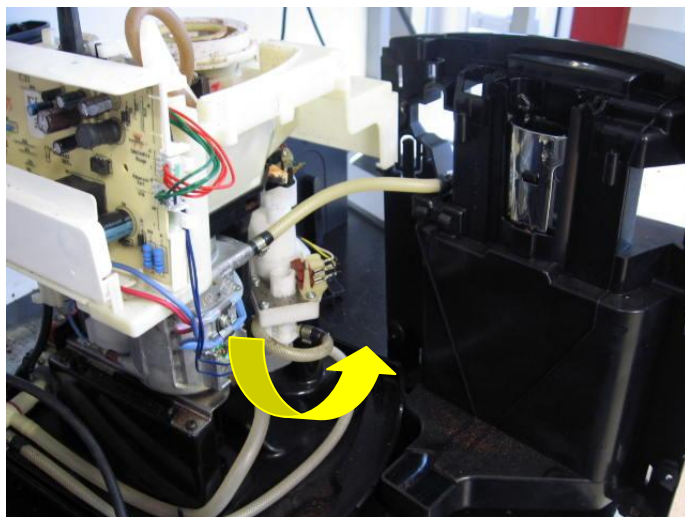

Open the panel to the right

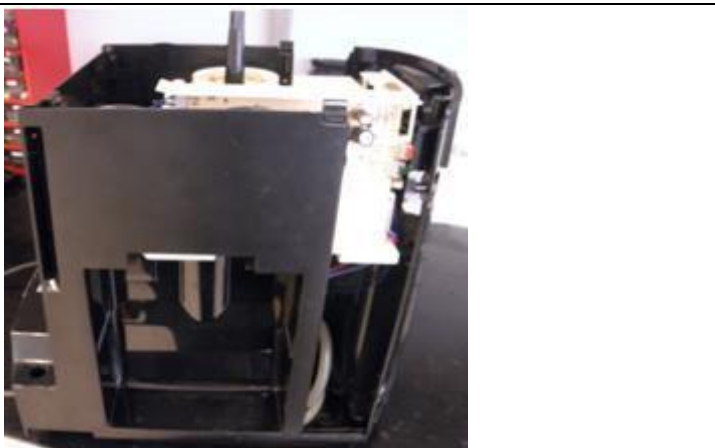

## 4.2 Grinder

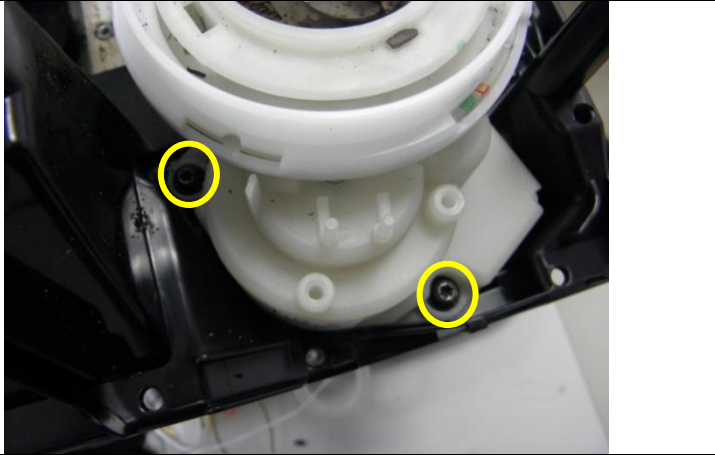
Tools: torx screwdriver (T15)

<p>Remove the protection</p>	
<p>Remove the crown who is on the grinder as the picture. A screwdriver can help</p>	
<p>Unscrew the 2 screw of the grinder</p>	
<p>Disconnect the plug of grinder (it's blacks wires)</p>	

Change the grinder

**BE CAREFUL:** the spring of the brewing unit must be in the good position.

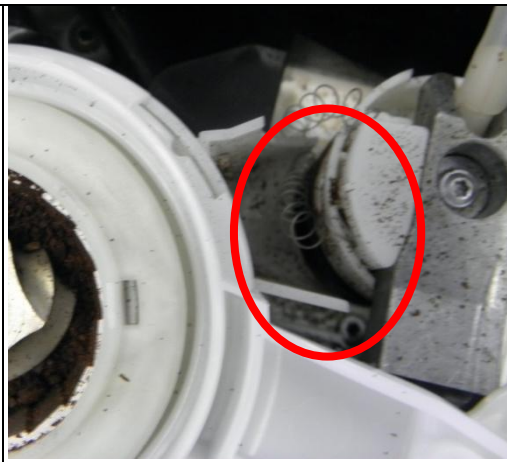

**NOK**

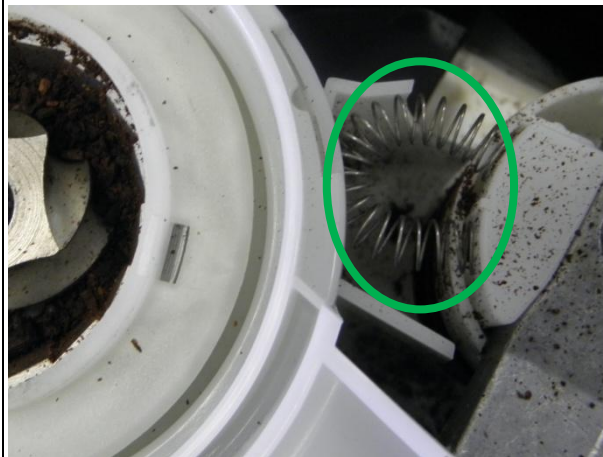

**OK**



Thread breaks mound

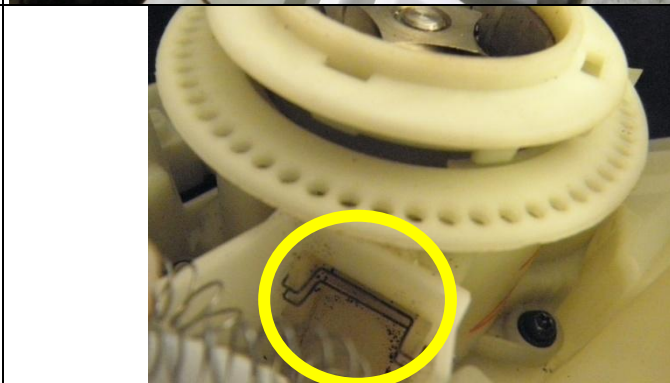

The little ball must be in the green mark, the grind drive must be in good position (like the picture). Put the crown when the two point are checked

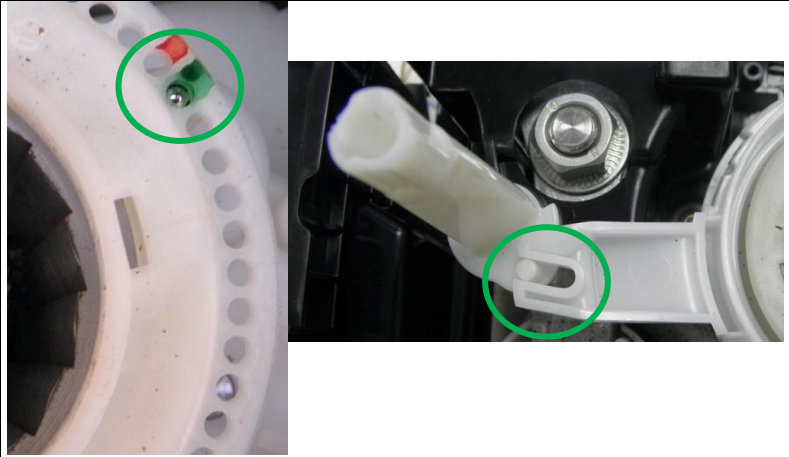

**OK**

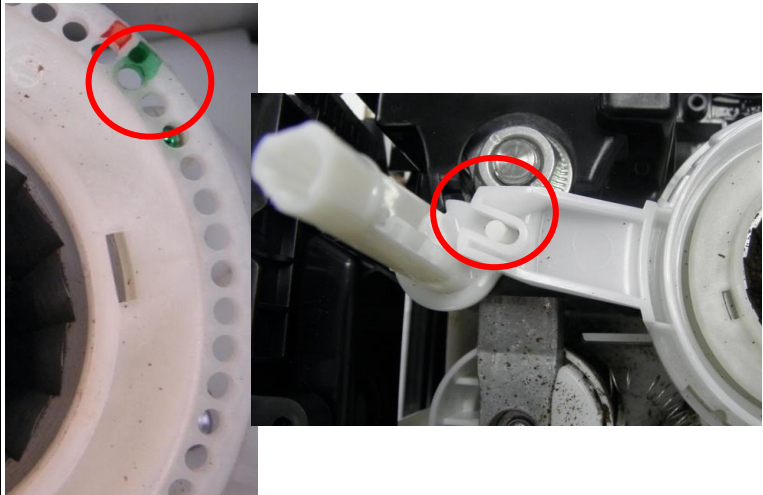

**NOK**

Connect the new grinder.  
The cables must be in good position

Put back all protections

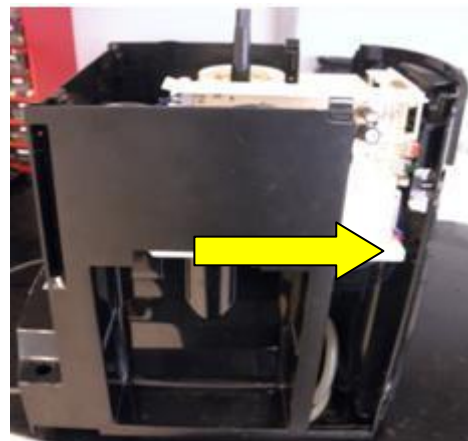

**4.3 Subassembly switch ejection**  
Tools: Torx screwdriver (T15)

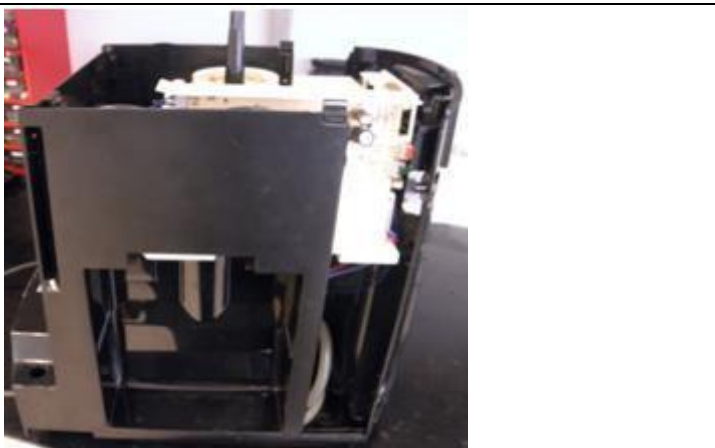
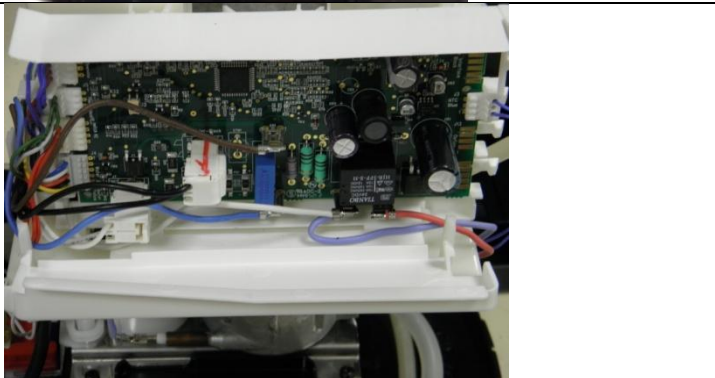
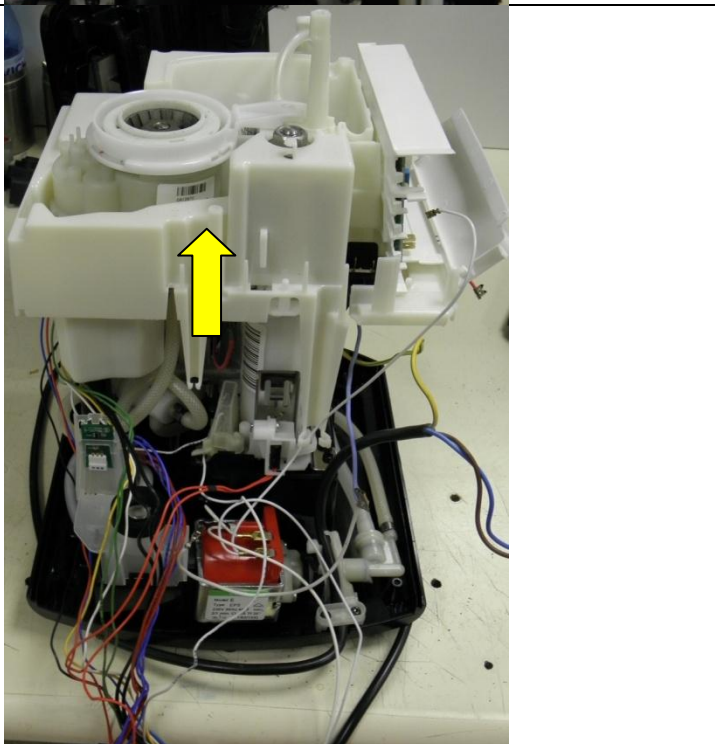
<p>Remove the protection</p>	
<p>Disconnected all wires of the power board</p>	
<p>Removed the subset grinder</p>	

Unscrew the 3 screws of thermobloc and tip up in back

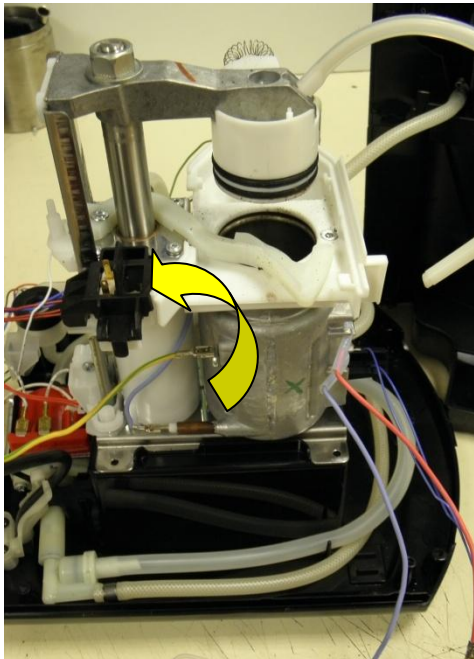
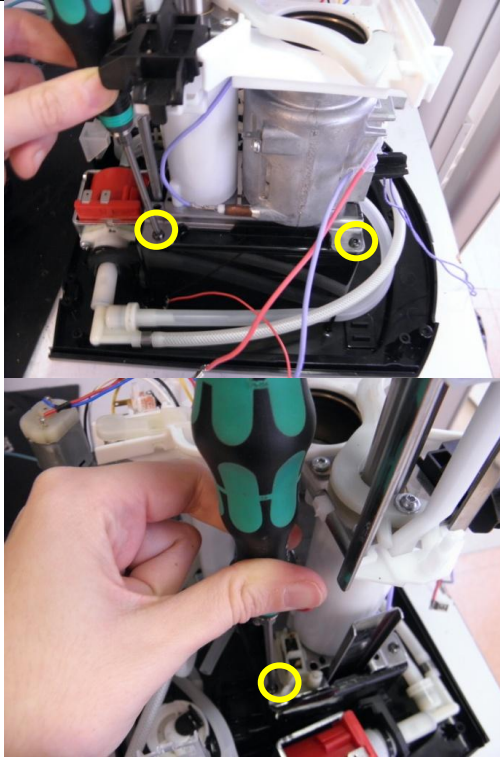

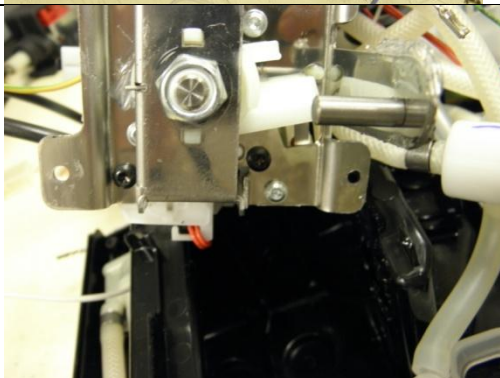

Unscrew the 2 screws of switch

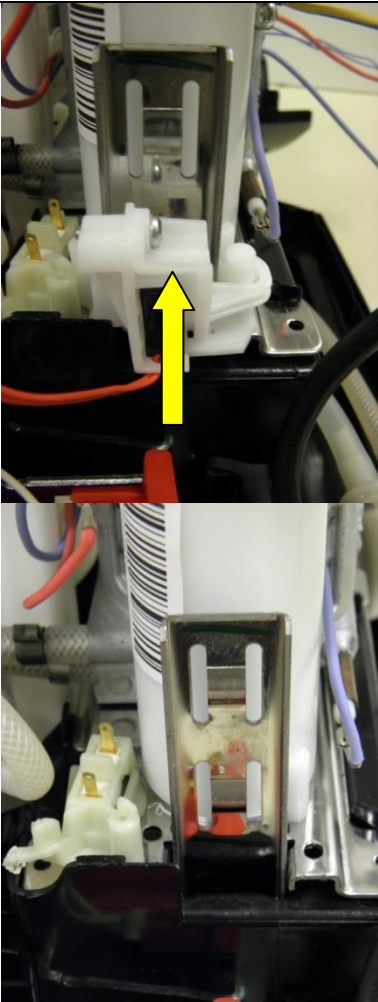

<p>Slide up the switch</p>	
<p>Change the switch and make the same actions to reassemble all the parts</p>	
<p>Perform a calibration</p>	

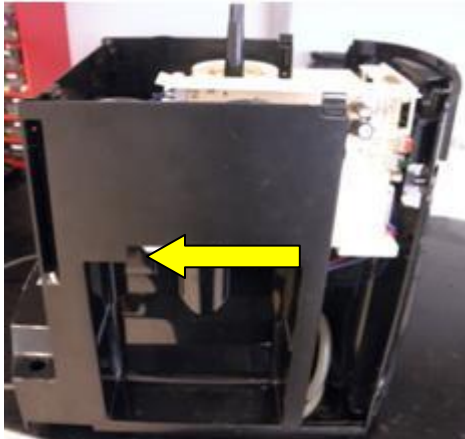
**4.4 Switch ejection disassembly**  
Tools: Torx screwdriver (T15 & T10)

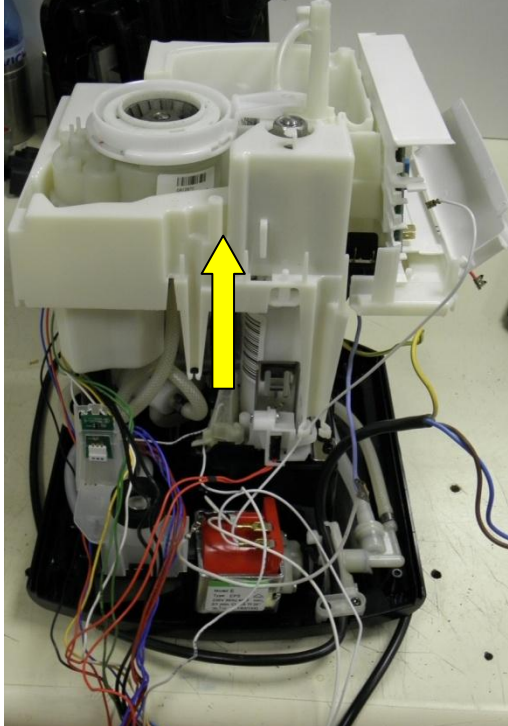
<p>Remove the protection</p>	
<p>Disconnected all wires of the power board</p>	
<p>Removed the subset grinder</p>	

Unscrew the screw



Tip over on the right the right side of switch bracket

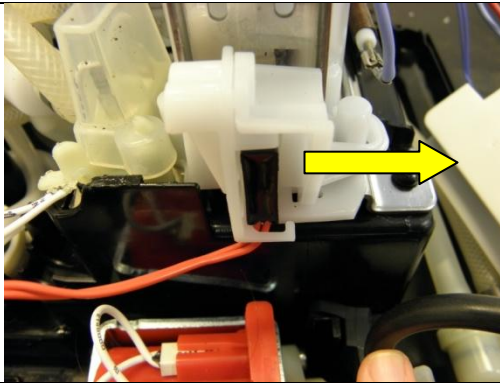

Removed the switch (help you of a screwdriver)

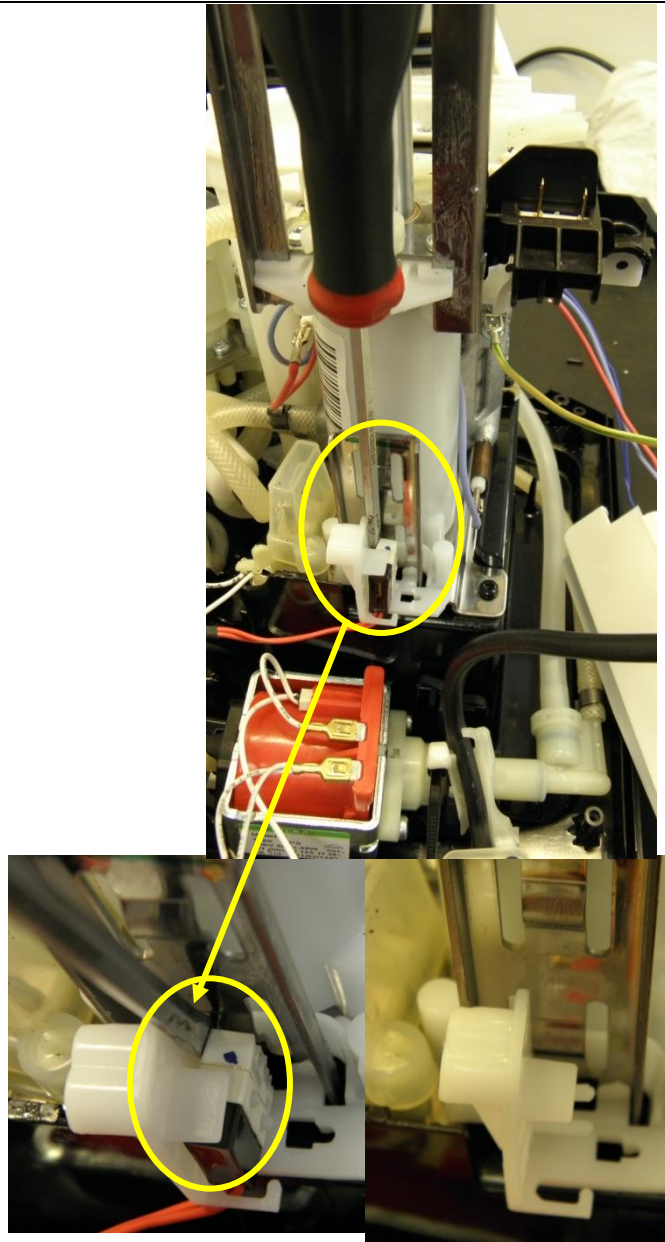

Make the same actions to reassemble all the parts

**BE CAREFUL** : put the switch in the good position (wire in the down)

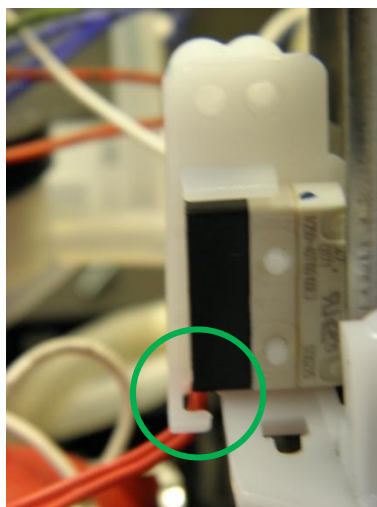

**OK**

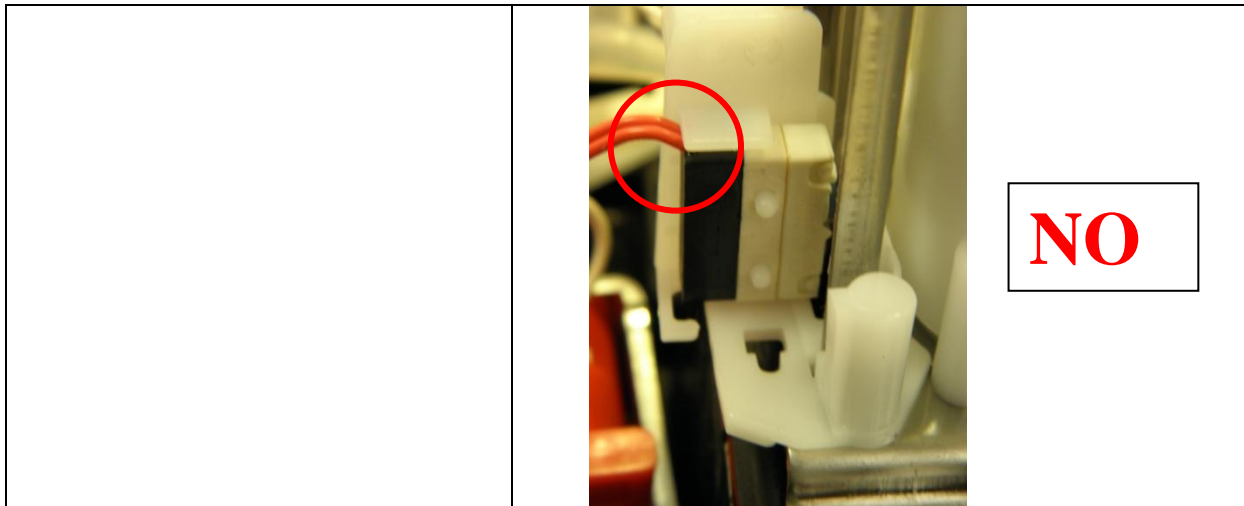

## 5 ASS Mode

### 5.1 ASS mode 1 :

Press on the same time on “SYSTEM” button + “Coffee” button + plug the coffee machine.

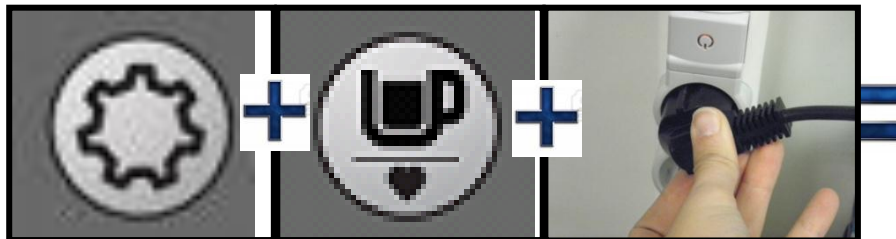

### 5.2 Scrolling ASS data :

All ASS informations will be able on the screen with 3 digits. For change function press on “+” button or “-“ button.

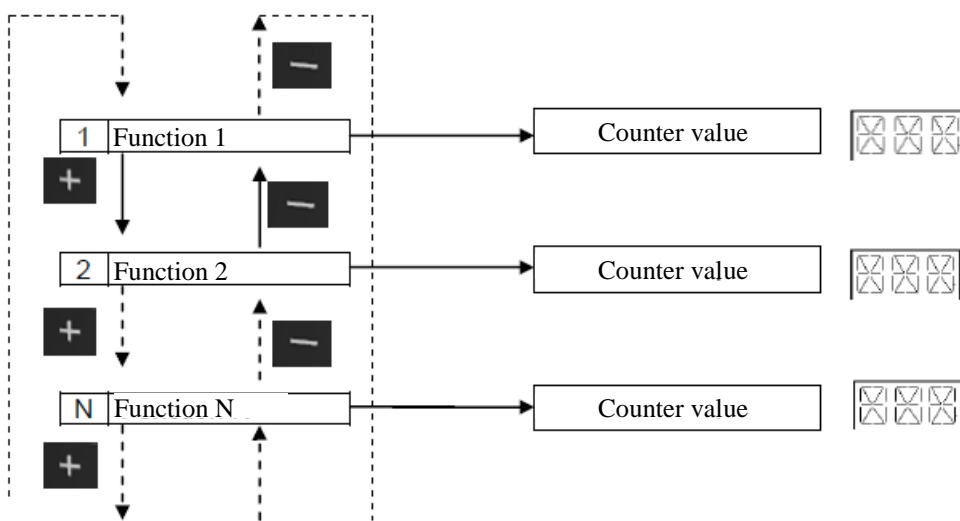

### 5.3 View ASS data :

The first two digits match the identification number of the function : Id SAV.  
The last digit will display the counter value or information. For a value of more than one digit, the value will be framed by two dashes and display will drop down (closed loop).

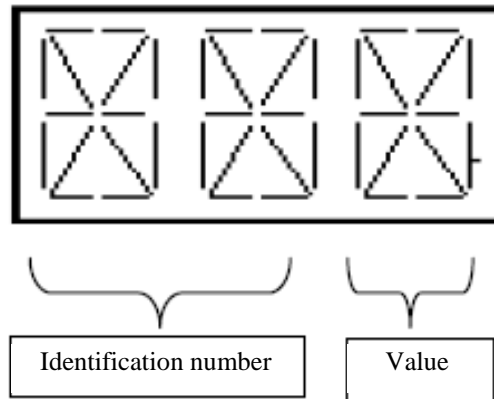

Example : Data for the line Id SAV 18 with 1500 coffees.

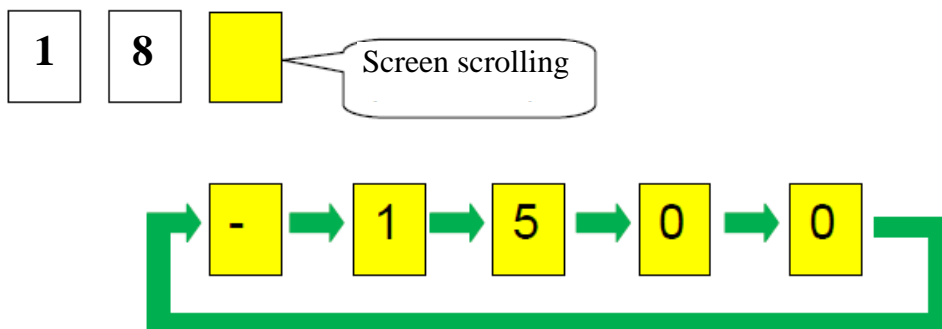

Example : Data for the line Id SAV 6 with 2 defects



#### 5.4 Ass Data description:

<b>Fonctions</b>	<b>Id SAV</b>
soft	1
list of 4 last defect	2
nbr of defect 1	3
nbr of defect 4	4
nbr of defect 5	5
nbr of defect 6	6
nbr of defect 7	7
nbr of defect 8	8
nbr of defect 9	9
nbr of defect 10	10
nbr of defect 12	11
nbr of defect 13	12
nbr of defect 14	13
nbr of defect 15	14
nbr of defect 16	15
nbr of defect 63	16
nbr of defect 64	17
nbr of coffee	18
nbr of coffee with 1 bean	19
nbr of coffee with 2 beans	20
nbr of coffee with 3 beans	21
nbr of steam	22
nbr of Cakes in the tank	23
Nbr of cycles of coffee made since the last cleaning	24
nbr of cleaning	25
Nbr of cycles of coffee made since the last descaling	26
nbr of descaling	27
nbr of rinsing	28
volum for favorit 1	29
volum for favorit 2	30
favorit strenght 1	31
favorit strenght 2	32
double cup favorit 1	33
double cup favorit 2	34
Overruns alarm Cleaning	35
Overruns alarm Descaling:	36
Activation of automatic rinse at start	37

Time for Auto Shut Off 15, 30, 45, 120 minutes (0-1-2-3-4)	38
water hardness (5 levels)	39
coffee temperature (3 levels)	40
for information	41
	42
	43
	44
	45
	46
	47
	48
	49
	50
	51
	52
	53
	54
	55
	56
	57
	58
	59
	60
	61
	62
	63
	64
	65
	66
	67
	68
	69
	70
	71
	72
	73
	74
	75

# 6 Process of calibration

## 6.1 Parts concerned :

After change the power PCB, the grinder or the heating element a calibration is necessary.

## 6.2 Access to calibration program:

All components (cake tank, tray and water tank full) ,gauge block and coffee bean must be present before start the process.



Place a container under the steam and coffee nozzle before starting the calibration.



For accessed at the calibration mode , press simultaneous on the button «START/STOP » and «NAVIGATION » and plug.



## 6.3 Calibration Cycle :

At the end of the complete calibration cycle ; if it is successful the pictogram « Disconnect / reconnect »  appear. Disconnect the product and the process is finish.

If any abnormality during the calibration cycle the ERROR message will appear on the display 3 digits (scrolling message). In this case, unplug and restart the process.

## 7 ASS Defect description

Defect	Designation	Priority	Parts to be checked
1	Distributor position issue: Time for distributor movement done and no action from distributor.	1	Distributor
4	Priming issue: Pump running=5sec & vol < 10ml	1	Claris filter
		2	Flow meter
5	Flow meter defect: Pump running and no flow	1	Flow meter
		2	Pump
		3	Pipes disconnected
6	Leakage in the water circuit during cylinder decent: Flow >50ml/min & vol measured >80ml	1	Distributor
		2	Thermoblock
		3	Pump valve
		4	Hole on the pipe
7	Actuator obstruction defect: Flow <50ml/min et vol measured <25ml	1	Claris Filter
		2	Flow meter
8	Coffee circuit blocked: After 5 seconds of disposal, flow <80ml/min	1	Thermoblock
		2	Crimped pipe
		3	Grinder (grinds are too fine)
9	CTN defect: Temperature too high or too low regarding the heating time	1	Thermoblock
		2	Compaction head gasket missing or defective
		3	Fuse KO
12	Ejection issue (4 times defect 13)	1	Thermoblock
13	Cake ejection defect: During cylinder upward, no ejection switch impulse	1	Thermoblock
14	Calibration defect: Lack of gauge or switch issue	1	No cake gauge
		2	Cake height switch

15	Calibration defect with empty tank or on the second coffee test: Wrong flow meter impulse nbr or calibration switch issue	1	Flow meter
		2	Cake heigh switch
16	Calibration defect during measure of the empty tank: Value measured with empty tank is not between 6 mm and 9.6 mm	1	Cake heigh switch
0A-10	Heating resistor issue: The heating has been actuated and the temperature has not change	1	Thermobloc
		2	Fuse wires red and/or blue
0C-0D-0E	Communication issues between Display and power boards	1	Both boards are not compatible
64	Default air jack: Default flow meter reading speed in the jack descent, the flow meter speed decreased and this for 8 seconds.	1	Remove the CLARIS cartridge and make a rince function
		2	Change flow meter
63-3F	Default air jack confirmed (after 2 default 64)	1	See defect 64