

The Harman Kardon Model Citation22 STEREO POWER AMPLIFIER

Manual 113A

Technical Manual

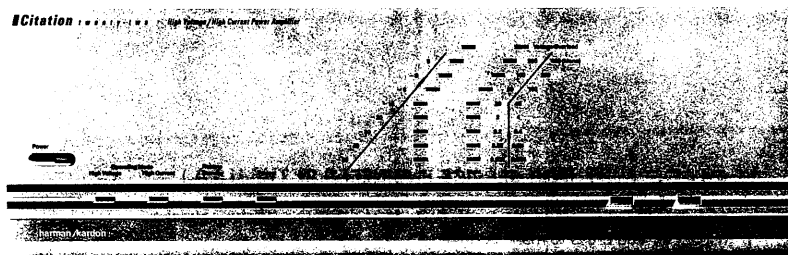

The following marks found in the parts list of this manual identify the models as follows.

- UA : North America area model
- G : General model
- N : Japan model

harman/kardon

240 Crossways Park West, Woodbury, N.Y. 11797
1112-3152113A7 P-088706 1500 Printed in Japan

SPECIFICATIONS

	Nominal	Limit		Nominal	Limit
Input Sensitivity	1.0V	$\pm 0.15V$	Power Bandwidth (1/2 rated power)	10Hz	~ 100kHz
Input Impedance at 1kHz	22k Ω	$\pm 2k\Omega$	IM Distortion Ratio at 1W	0.01%	≤ 0.08
Frequency Response	0.07Hz	~ 578kHz	Damping Factor at 1kHz	139	≥ 100
Signal to Noise Ratio	100.3dB	$\geq 90dB$	DC Balance	0mV	$\pm 60mV$
Channel Separation at 10kHz	92dB	$\geq 75dB$	Idling Current	16mV	$\pm 2mV$ (32mV \pm 3mV)
Total Harmonic Distortion			Dimensions (W x H x D)	17-3/8"	\times 6-1/8" \times 15-11/16"
20Hz	0.01%	$\leq 0.08\%$	Weight	45 lbs.	(20.5kg)
1kHz	0.006%	$\leq 0.08\%$	Power Supply		
20kHz	0.01%	$\leq 0.08\%$	North America area model	AC 120V, 60Hz	
RMS Output Power			General model	AC 220V/240V, 50/60Hz	
8 Ω , 1kHz, THD 0.08%/ch.	224W	$\geq 200W$	Japan model	AC 100V, 50/60Hz	
4 Ω , 1kHz, THD 0.08%/ch.	228W	$\geq 200W$	Power Consumption	610W	

This specification is the target of servicing.
But, there is a case that the specification is not applicable to the measurement condition and instrument.

Specifications and components subject to change without notice. Overall performance will be maintained or improved.

LEAKAGE TEST (FOR SERVICE ENGINEERS IN THE U.S.A.)

Before returning the unit to the user, perform the following safety checks:

1. Inspect all lead dress to make certain that leads are not pinched or that hardware is not lodged between the chassis and other metal parts in the unit.
2. Be sure that any protective devices such as nonmetallic control knobs, insulating fishpapers, cabinet backs, adjustment and compartment covers or shields, isolation resistor-capacity networks, mechanical insulators, etc. which were removed for servicing are properly reinstalled.
3. Be sure that no shock hazard exists; check for leakage current using Simpson Model 229 Leakage Tester, standard equipment item No. 21641, RCA Model WT540A or use alternate method as follows:

Plug the power cord directly into a 120-volt AC receptacle (do not use an Isolation Transformer for this test). Using two clip leads, connect a 1500 Ohm, 10-watt resistor paralleled by a 0.15 μ F capacitor, in series with all exposed metal cabinet parts and a known earth ground, such as a water pipe or conduit. Use a VTVM or VOM with 1000 Ohms per volt, or higher sensitivity to measure the AC voltage drop across the resistor. (See Diagram.) Move the resistor connection to each exposed metal part having a return path to the chassis (antenna, metal, cabinet, screw heads, knobs and control shafts, escutcheon, etc.) and measure the AC voltage drop across the resistor. (This test should be performed with the power switch in both the On and Off positions.)

A reading of 0.35 volt RMS or more is excessive and indicates a potential shock hazard which must be corrected before returning the unit to the owner.

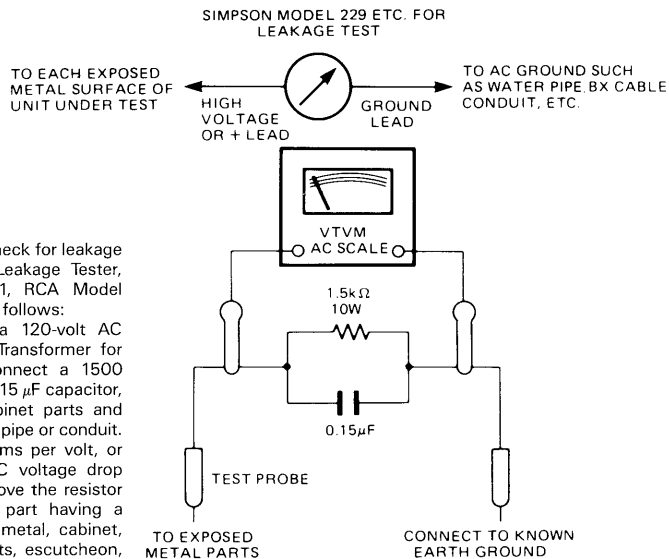

DISASSEMBLY PROCEDURES (REFER TO PAGES 5 THROUGH 10 AND 24)**1 CABINET TOP (131) REMOVAL**

Remove 10 screws (A) and then remove the Cabinet Top (131).

2 FRONT PANEL ASS'Y REMOVAL

1. Remove the Cabinet Top (131), referring to the previous step 1.
2. Remove 5 screws (B) and then remove the Front Panel Ass'y (AA).

3 CABINET BOTTOM (133) REMOVAL

1. Remove 10 screws (C) and then remove the Cabinet Bottom (133).

4 MAIN P. C. BOARD (PCB-1) REMOVAL

1. Remove the Front Panel Ass'y (AA), referring to the previous step 2.
2. Open the lid of connectors (CN1 and CN2) on the Main P. C. Board (PCB-1) and then disconnect the lead wires.
3. Open the lid of connector (CN5) on the Power Level Indicators P. C. Board (PCB-9) and then disconnect the lead wire.
4. Unsolder the lead wires connected to the Main P. C. Board (PCB-1), Power Level Indicators P. C. Board (PCB-9) and Pre Driver P. C. Board (PCB-10).
5. Remove 11 screws (D) and then remove the Main P. C. Board (PCB-1) with Heat Sinks (179, 180 and 181) and Pre Driver P. C. Board (PCB-10).

6. Remove 2 screws (E) and unsolder the connectors (CN10, CN11, CN12, CN13 and CN14) and then remove the Pre Driver P. C. Board (PCB-10) from Main P. C. Board (PCB-1).

7. Unsolder the lead wires from PT1, PT2, D409 and D410.

8. Unsolder the transistors (Q437~Q456) and remove 6 screws (F) and then remove the Heat Sinks (179, 180 and 181) with transistors, PT1, PT2, D409 and D410.

5 RELAY P. C. BOARD (PCB-12) REMOVAL

1. Remove the Front Panel Ass'y (AA), referring to the previous step 2.
2. Remove 3 screws (G) and then remove the Relay P. C. Board (PCB-12).
If necessary, unsolder the lead wires connected to the PCB-12.

6 POWER LEVEL INDICATORS P. C. BOARD (PCB-9) REMOVAL

1. Remove the Relay P. C. Board (PCB-12), referring to the previous step 5.
2. Remove 12 screws (H) and then remove the Chassis (161) with the Power Level Indicators P. C. Board (PCB-9), LED P. C. Board (PCB-13) and Power Switch P. C. Board (PCB-14).
3. Unbend 4 catches fixing the Power Level Indicators P. C. Board (PCB-9) and remove it.
If necessary, unsolder the lead wires connected to the PCB-9.

POWER CORD REPLACEMENT (FOR SERVICE ENGINEERS OTHER THAN NORTH AMERICA)

In order to prevent fire or shock hazard when replacing the power cord, follow the procedure below to replace the parts with the standard supply parts.

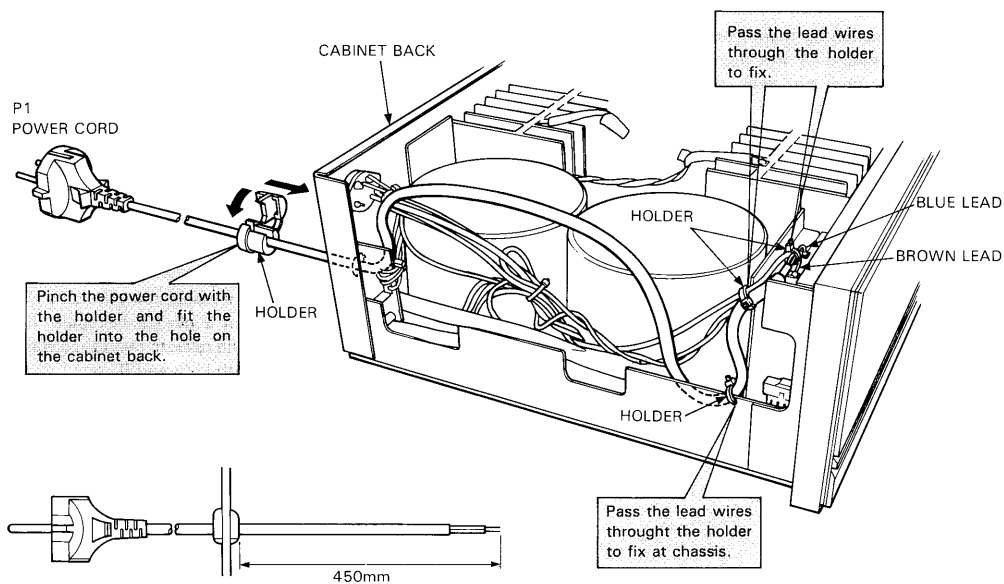

ALIGNMENT PROCEDURES (REFER TO PAGES 11 THROUGH 15 AND 23)**1. DC BALANCE ADJUSTMENT**

- Set the Speaker Operating Mode switch for both L and R channels to the 4Ω position.
- Allow 20 minutes' aging.
- Connect a Digital Voltmeter to the speaker terminal and adjust VR401 (L ch) and VR402 (R ch) so that $\pm 0\text{mV}$ DC voltage is obtained.
- Set the Speaker Operating Mode switch for both L and R channels to the 8Ω position.
- Allow 10 minutes' aging.
- Connect a Digital Voltmeter to the speaker terminal and check to make sure that DC voltage is $\pm 60\text{mV}$.

2. IDLING CURRENT ADJUSTMENT

- Connect a 100Ω resistance as shown in the figure and adjust VR403 (L ch) and VR404 (R ch) so that TP1-to-TP2 voltage and TP3-to-TP4 voltage add up to $16\text{mV} \pm 2\text{mV}$.
- After adjusting the idling current, check again to ensure that the DC balance is properly maintained.

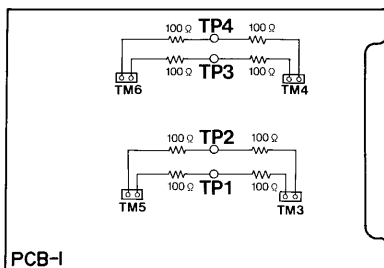
**3. POWER LEVEL METER ADJUSTMENT**

- Turn on the Display switch and set the sensitivity select switch to the 8Ω position.
- Apply a 1kHz signal so that the output becomes 100W (28.3V).
- Adjust VR101 (L ch) and VR102 (R ch) so that the third (100W) LED from the top lights.
- Adjust the input so that 0.69V output is obtained, then adjust VR103 (L ch) and VR104 (R ch) so that the second (0.02W) LED from the bottom lights.
- Adjust the input so that 100W (28.3V) output is obtained, then check to make sure that the third (100W) LED from the top lights.
- Check that the third (100W) LED from the top goes off when the input is decreased by 1dB.

CIRCUIT DESCRIPTION

- Protection circuit by thermistors PT1 and PT2**

As the temperature of the thermistors (PT1 and PT2) installed to the heat sink rises, their resistance reduces. Then Q8 turns OFF followed by Q7, Q6 and Q1 which all turn OFF, while Q2 and Q3 turn ON. As the level of Q3 collector becomes LOW in this state, Q401, Q417 (L ch) and Q402, Q418 (R ch) turn ON to mute the input signal. When in the monaural mode, the R ch is muted by Q87 and Q418.

- Remote power ON/OFF**

During stand-by, the input of the remote power is kept at LOW level, so HIGH level input is entered into 7 pin (SET) of Flip-Flop IC201 and LOW level input into 4 pin (RESET), making the level of 1 pin (Q) HIGH. And this causes Q202 to turn ON and LED's D204 and D205 to light.

When HIGH level input is entered into the input of the remote power in this state, Q201 turns ON, the level of 7 pin (SET) becomes LOW and that of 4 pin (RESET) becomes HIGH. This then makes the level of 1 pin (Q) LOW and Q202 turn OFF. As a result, the LED turns OFF. As the same time the level of 2 pin (Q) becomes HIGH and Q204 turns ON, making the relay to operate to supply power to the amplifiers of both L ch and R ch.

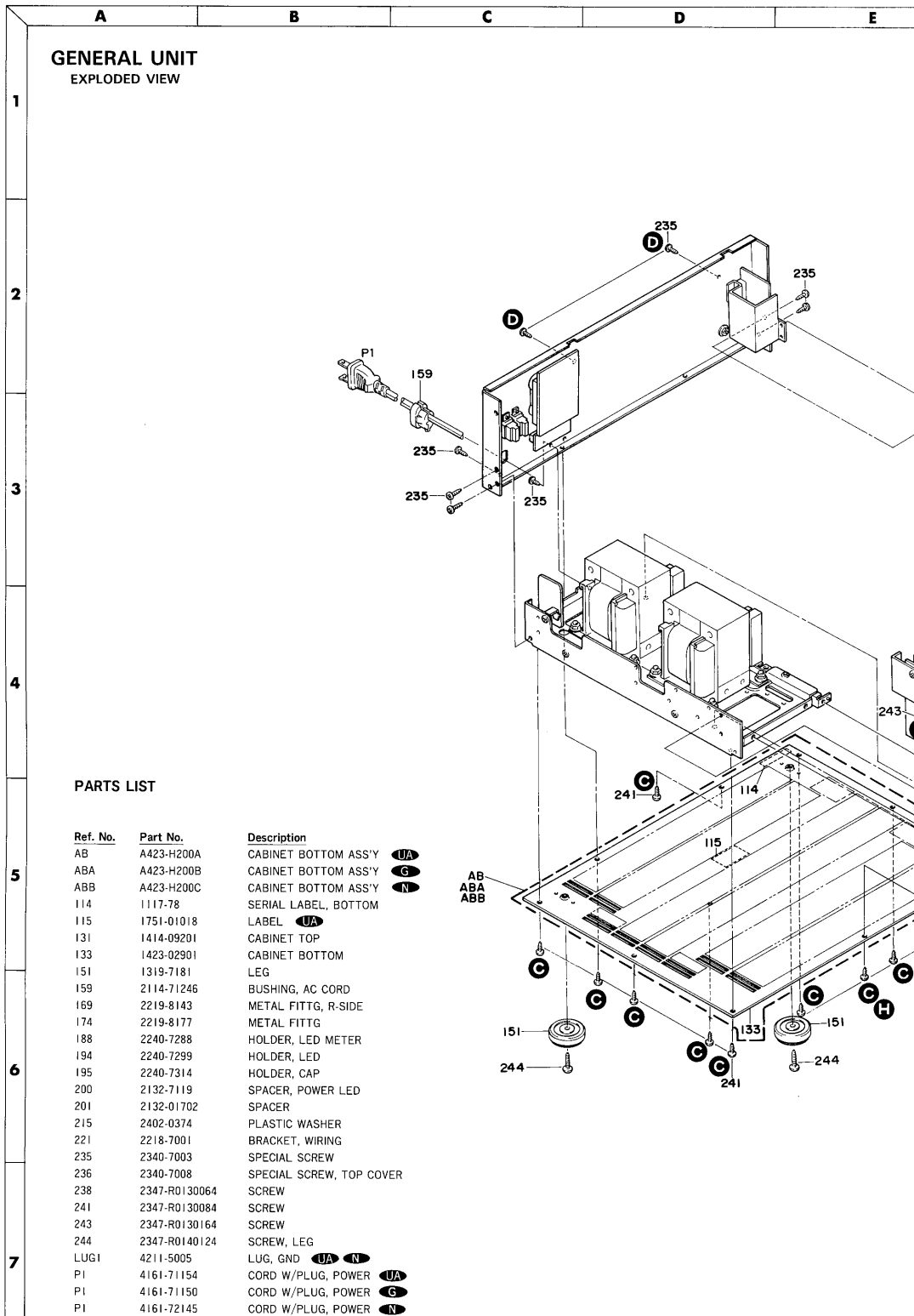

E	F	G	H	I	J
---	---	---	---	---	---

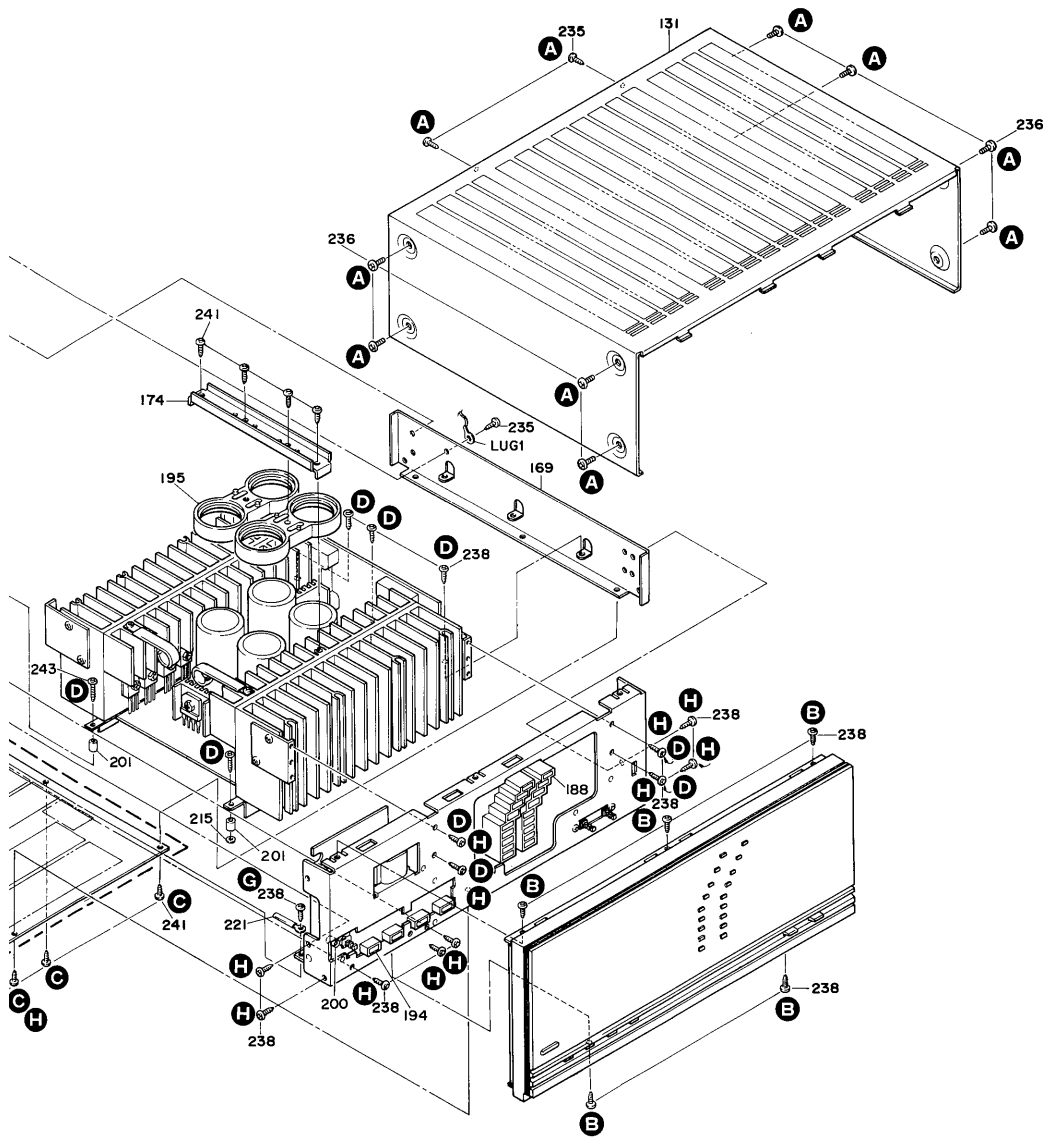

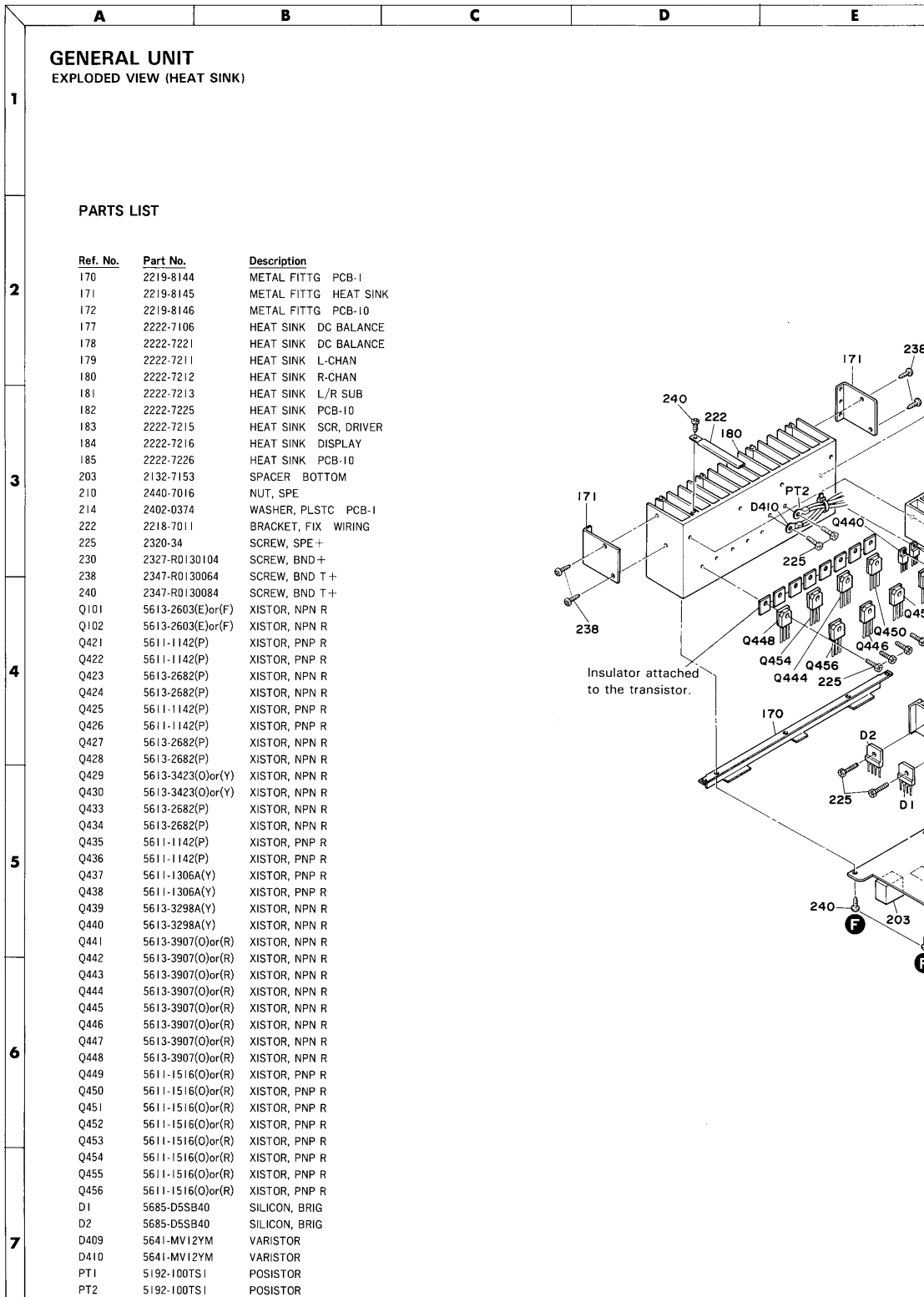

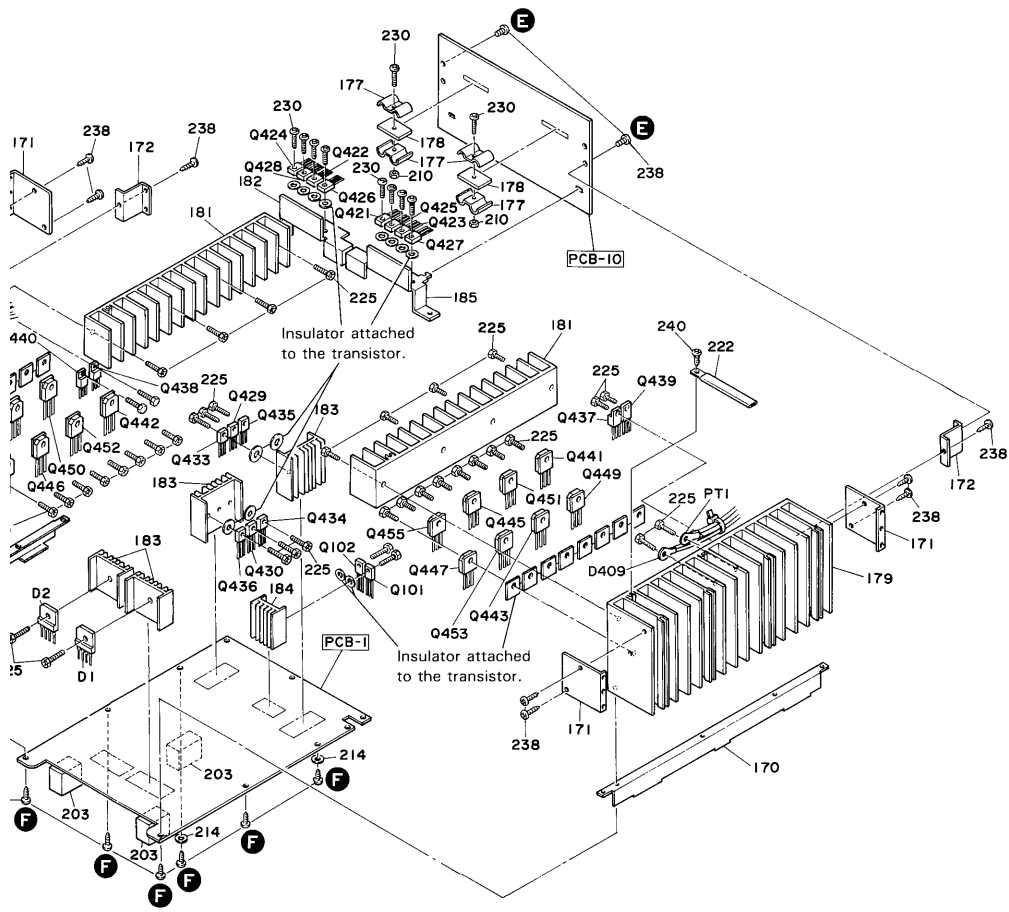

GENERAL UNIT
EXPLODED VIEW (FRONT PANEL ASS'Y)

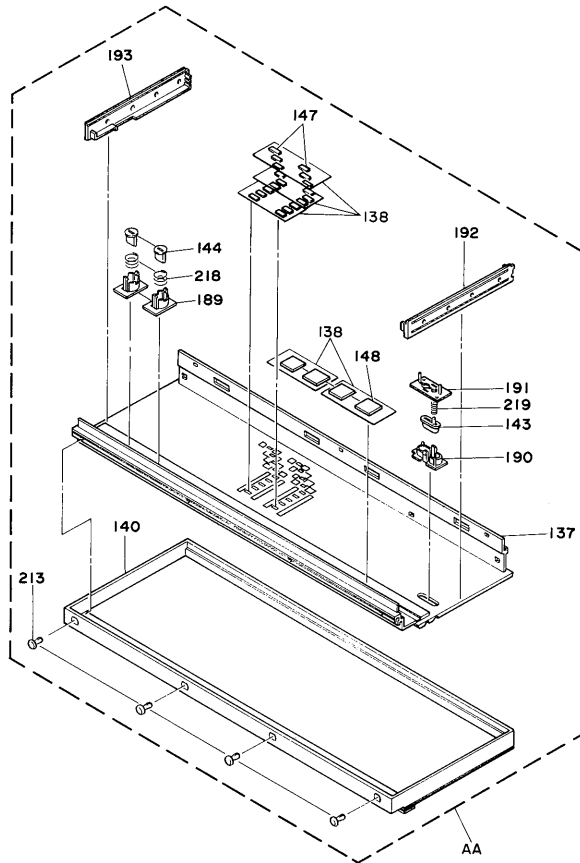

PARTS LIST

Ref. No.	Part No.	Description	Ref. No.	Part No.	Description
AA	A443-H200A	FRONT PANEL ASS'Y	189	2240-7289	HOLDER
137	1443-10601	PANEL	190	2240-7290	HOLDER, POWER
138	1223-11749	SOFT SHEET	191	2240-7291	HOLDER, POWER
140	1562-05401	FRAME	192	2240-7292	HOLDER, L-SIDE
143	1662-30401	PUSH BUTTON, POWER	193	2240-7293	HOLDER, R-SIDE
144	1662-30501	PUSH BUTTON	213	2459-3005511	PLASTIC RIVET, FRAME
147	1732-03601	INDICATOR	218	2651-2101726	SPRING
148	1732-03701	INDICATOR	219	2651-2101727	SPRING, POWER

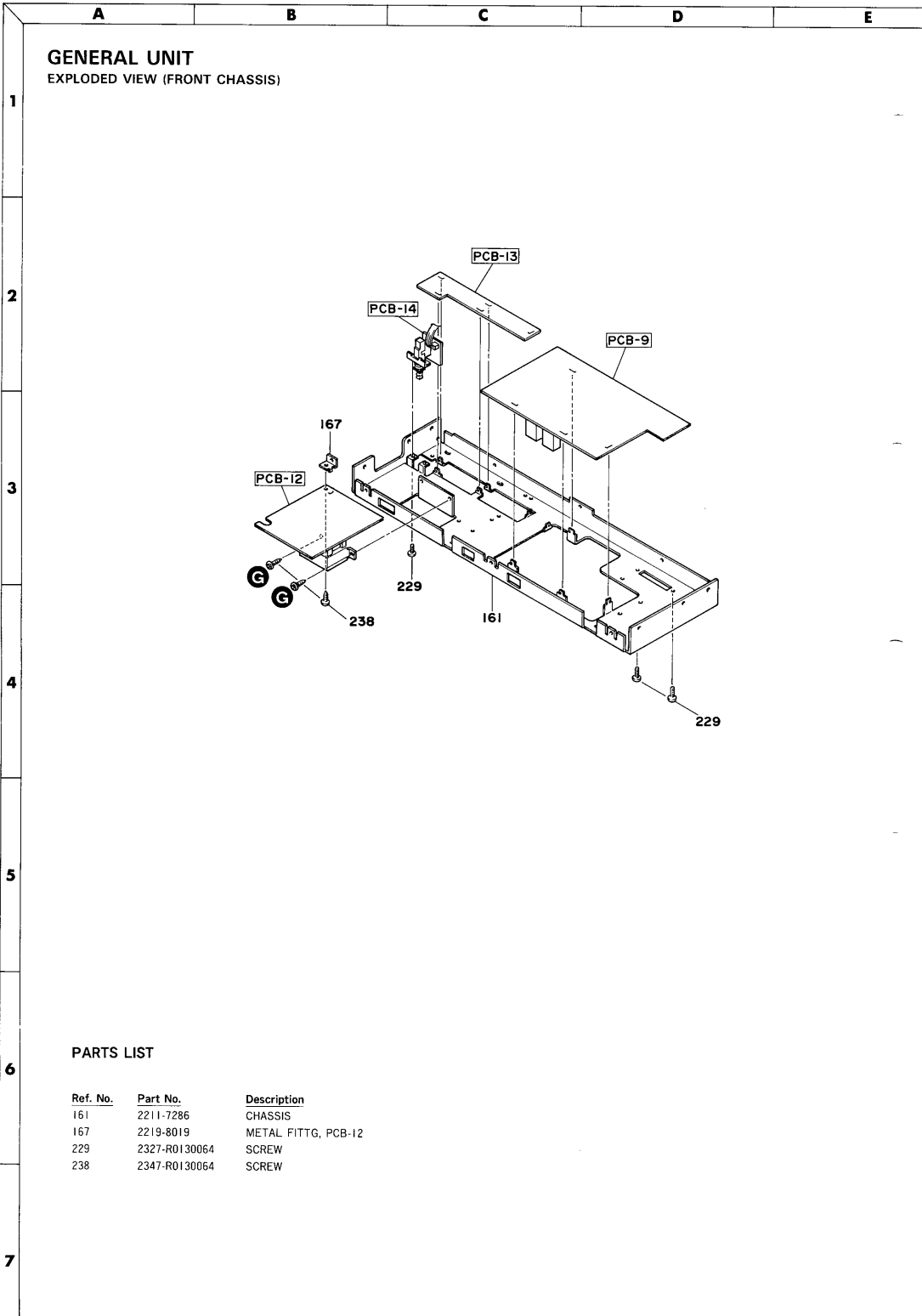

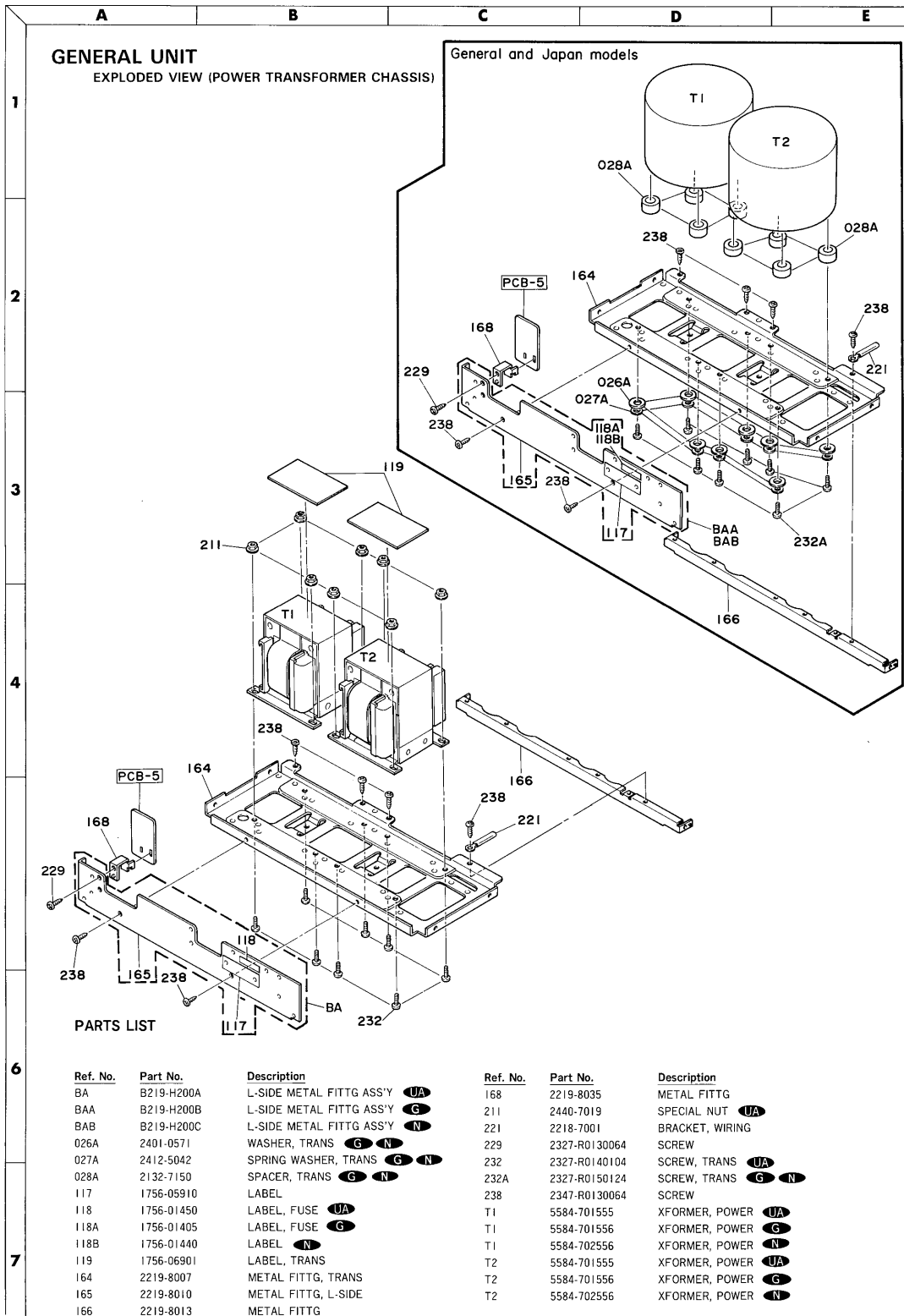

A B C D E

GENERAL UNIT
EXPLODED VIEW (CABINET BACK ASS'Y)

1

2

3

4

5

6

7

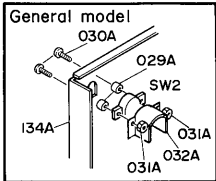
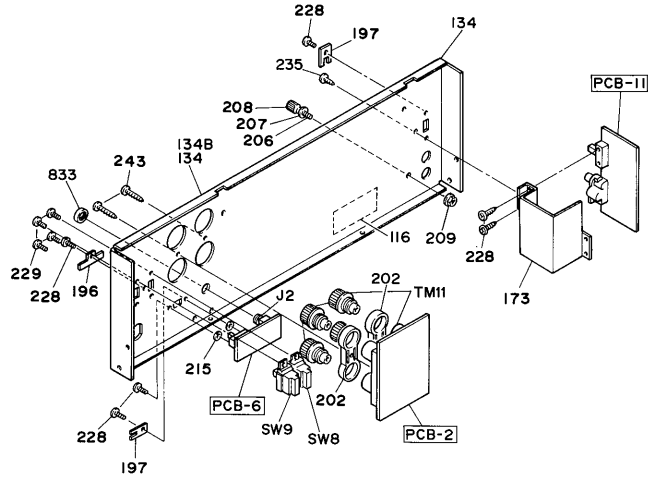

PARTS LIST

Ref. No.	Part No.	Description	Ref. No.	Part No.	Description
029A	2132-01406	SPACER, VOLT SELECT (G)	208	2440-7027	SPECIAL NUT, GND
030A	2327-R0130164	SCREW, VOLT SELECT (G)	209	2440-7016	SPECIAL NUT, GND
031A	2440-7016	SPECIAL NUT, VOLT SELECT (G)	215	2402-0374	PLASTIC WASHER
116	1756-CSA	LABEL, CSA (UA)	228	2327-260549	SCREW, SLIDE SW
134	1424-21301	CABINET BACK, REAR (UA)	229	2327-R0130064	SCREW
134A	1424-21303	CABINET BACK, REAR (G)	235	2340-7003	SPECIAL SCREW
134B	1424-21302	CABINET BACK, REAR (N)	243	2347-R0130164	SCREW
173	2219-8147	METAL FITTG, PCB-11	833	2440-7028	SPECIAL NUT
196	2240-7311	HOLDER, SW8/SW9	J2	4451-00177	JACK, IP
197	2240-7233	HOLDER	SW2	4411-1047112	SWITCH, ROTARY (G)
202	2132-7151	SPACER	SW8	4421-0227230	SWITCH, SLIDE
206	2310-7036	SPECIAL SCREW, GND	SW9	4421-0227230	SWITCH, SLIDE
207	2410-7018	SPECIAL WASHER, GND	TM11	4214-184	TERMINAL

E F G H I J

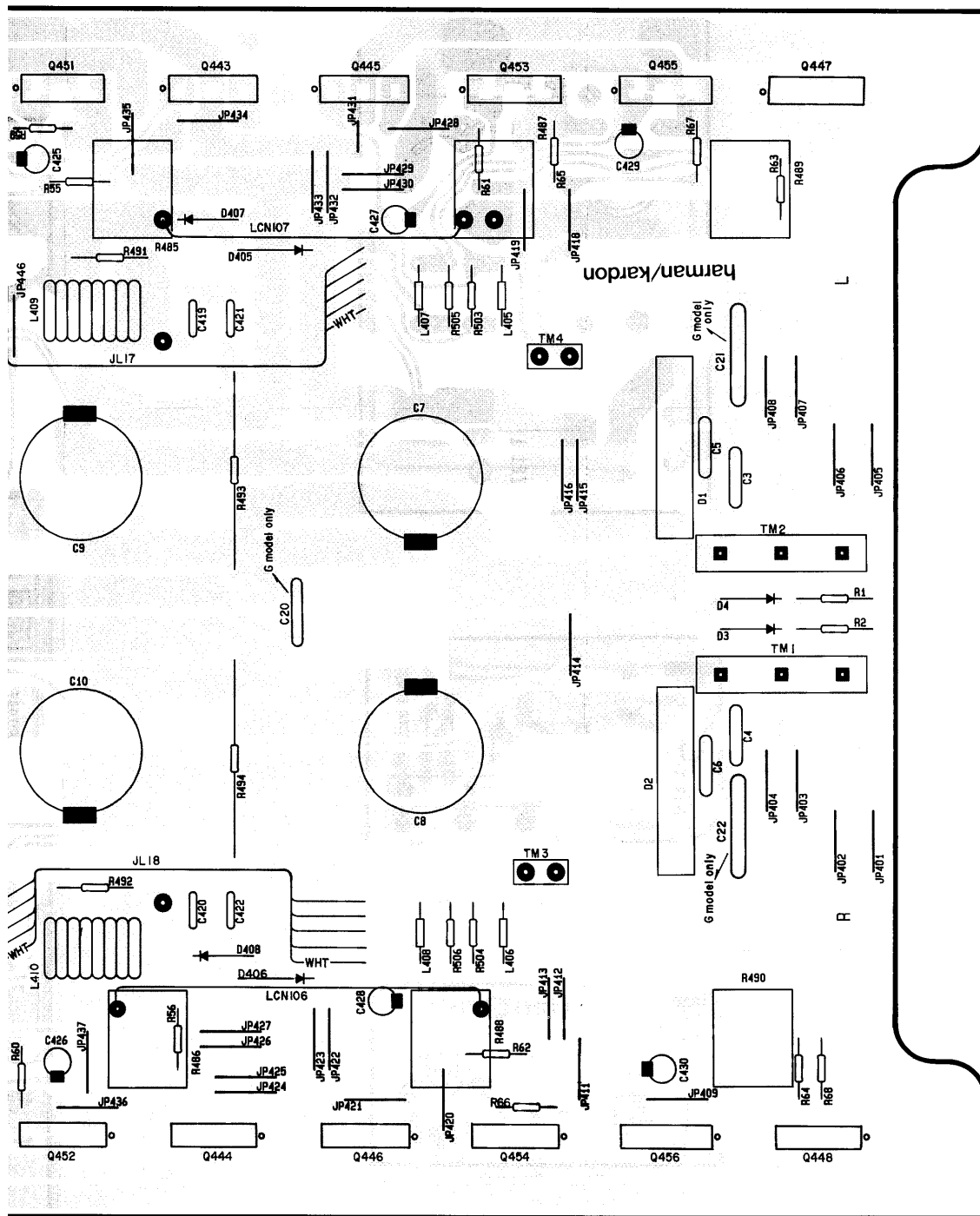

A B C D E

P. C. BOARDS

1

PCB-2 Speaker Terminal P. C. Board

2

3

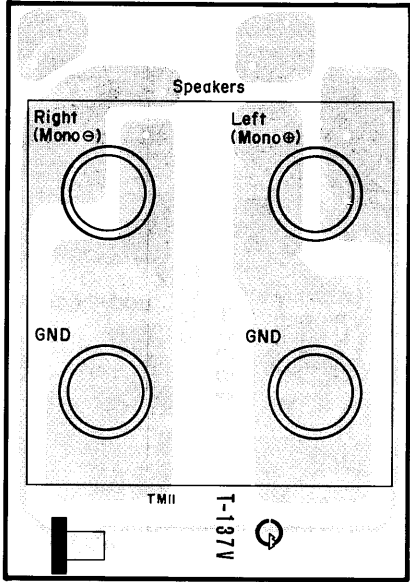

4

PCB-5 Protection P. C. Board

5

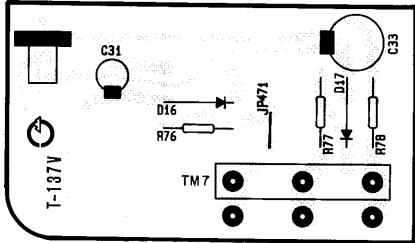

6

PCB-6 Remote Power P. C. Board

7

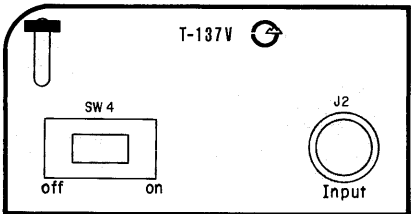

Remote Power On

PCB-9 Power Level Indicators P. C. Board

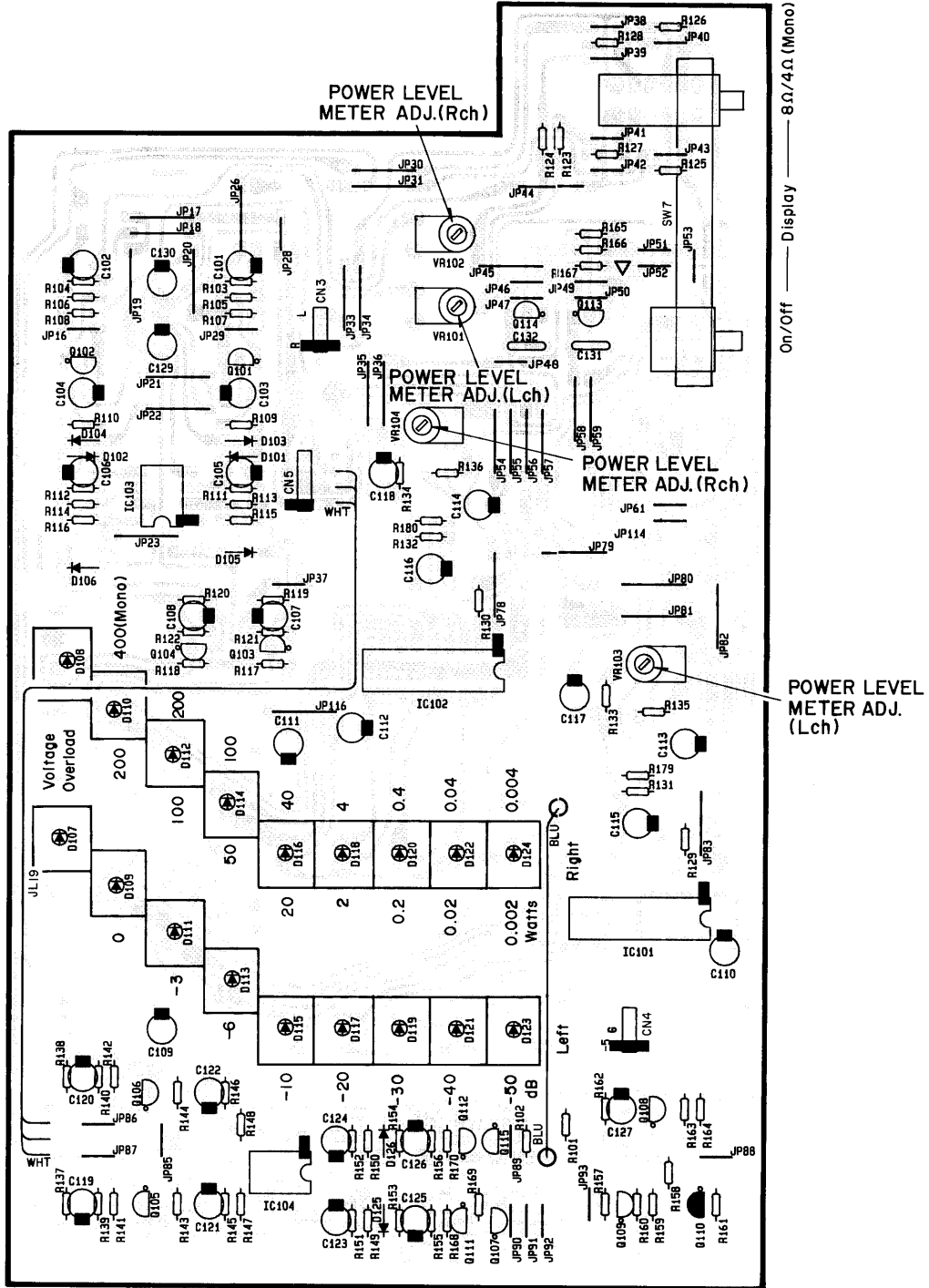

P. C. BOARDS

PCB-10 Pre Driver P. C. Board

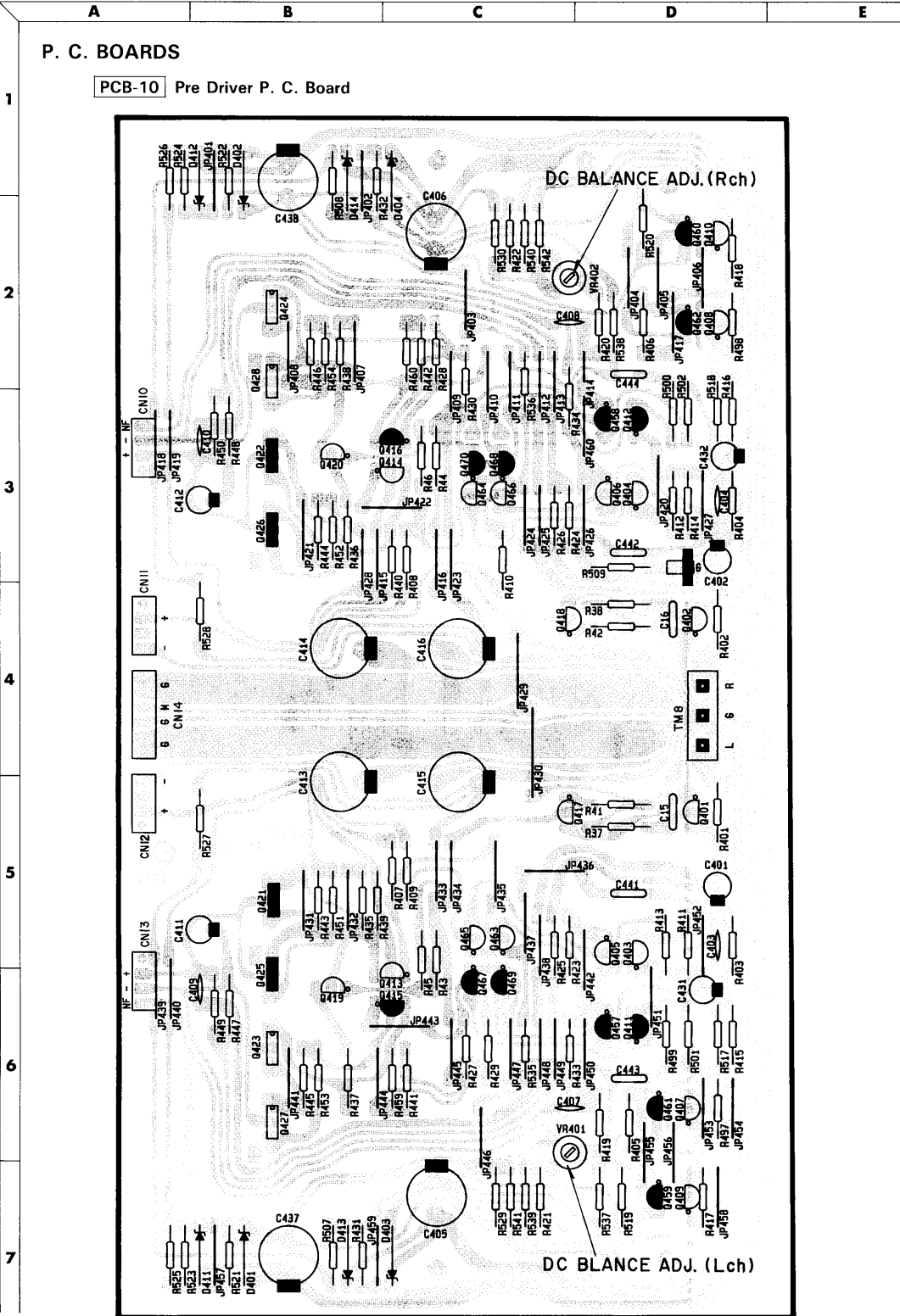

P. C. BOARDS

PCB-11 Input Jack P. C. Board

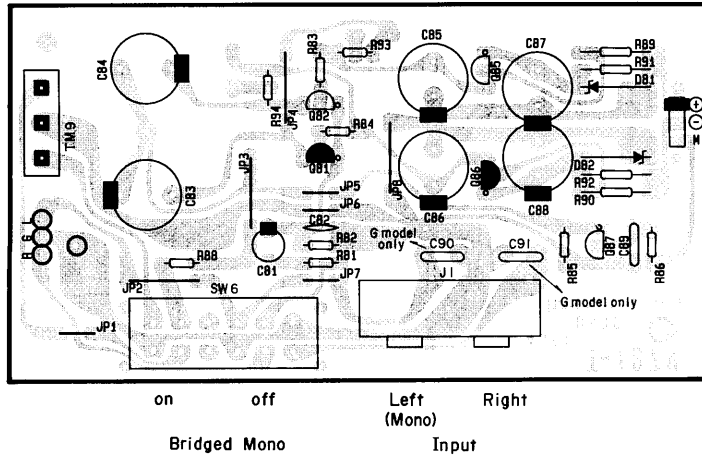

PCB-12 Relay P. C. Board

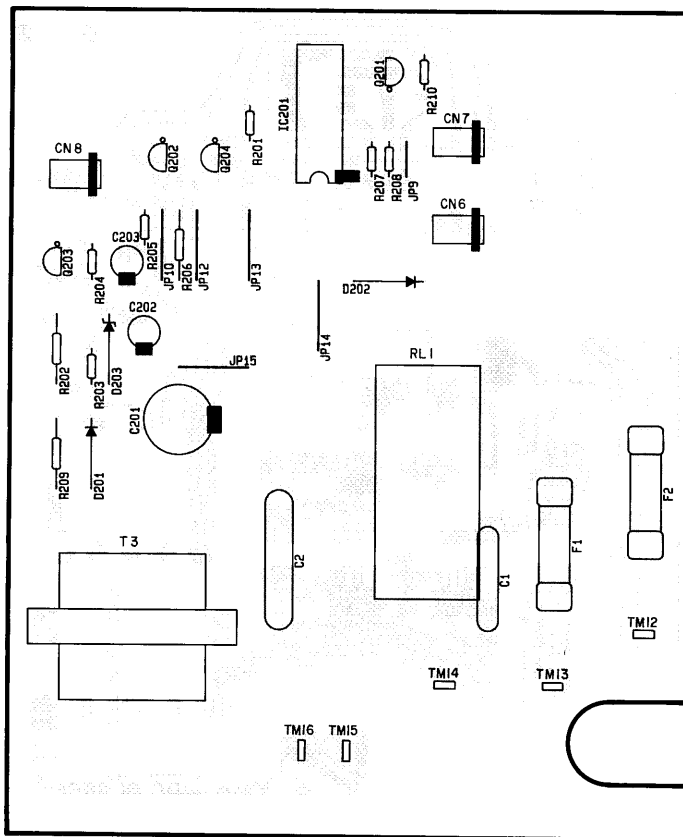

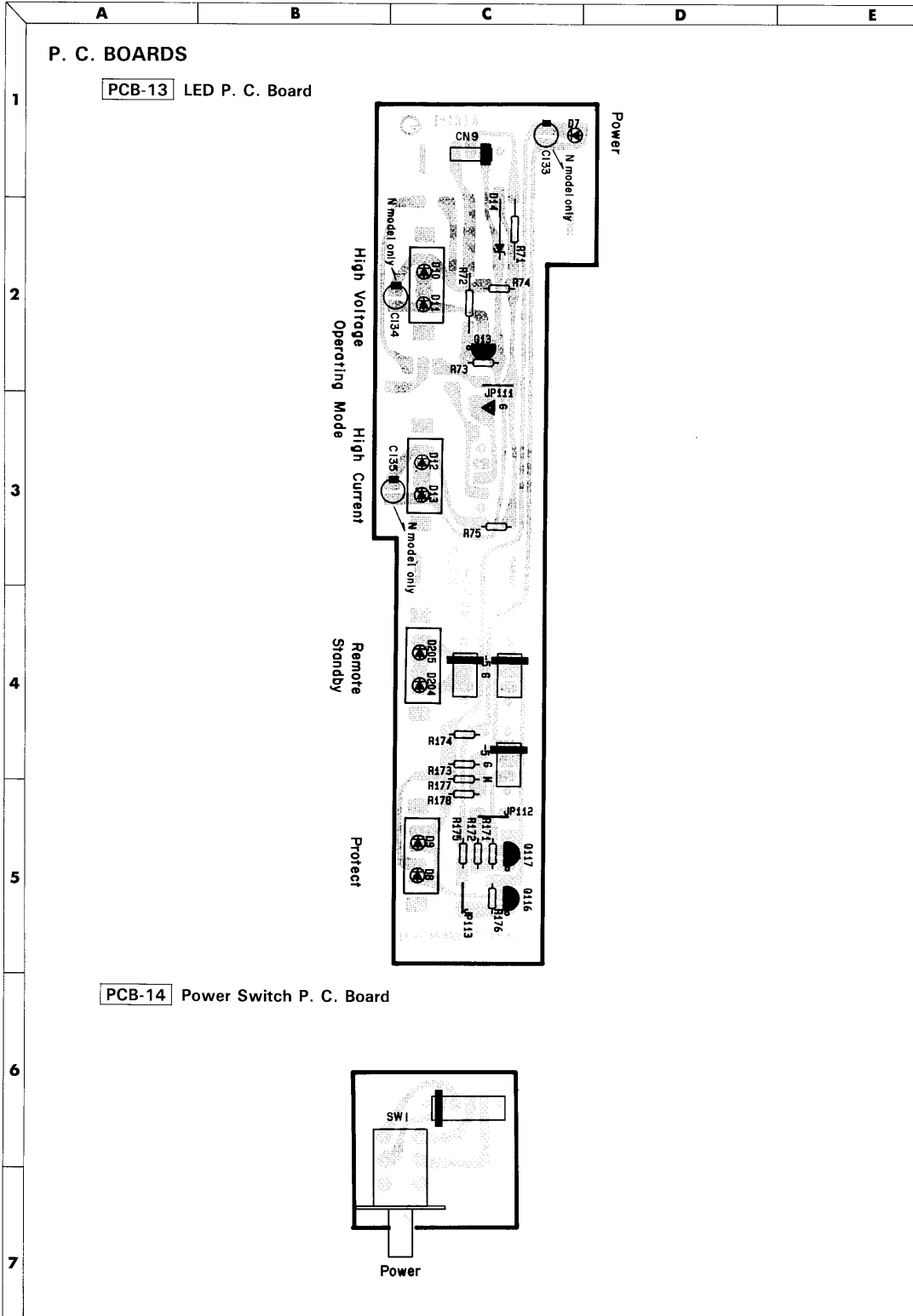

ELECTRICAL PARTS LIST

Ser. No.	Ref. No.	Part No.	Description	Ser. No.	Ref. No.	Part No.	Description
PCB-1 MAIN P.C.BOARD							
CAPACITORS							
583	C3	5352-1041957	CAP, MTL .1 μ	706	R40	5232-472J16P	RES, CBN 1/6P 4.7K
583	C4	5352-1041957	CAP, MTL .1 μ	721	R47	5232-562J16P	RES, CBN 1/6P 5.6K
583	C5	5352-1041957	CAP, MTL .1 μ	727	R48	5135-562522	RES, CBN 1/2P 5.6K
583	C6	5352-1041957	CAP, MTL .1 μ	721	R49	5232-562J16P	RES, CBN 1/6P 5.6K
798	C7	5341-109J0966	CAP, ELE 10000 μ /100V UA G	727	R50	5135-562522	RES, CBN 1/2P 5.6K
798B	C7	5341-109J0285	CAP, ELE 10000 μ /100V N	722	R51	5232-272J16P	RES, CBN 1/6P 2.7K
798	C8	5341-109J0966	CAP, ELE 10000 μ /100V UA G	722	R52	5232-272J16P	RES, CBN 1/6P 2.7K
798B	C8	5341-109J0285	CAP, ELE 10000 μ /100V N	728	R53	5135-101522	RES, CBN 1/2P 100
798	C9	5341-109J0966	CAP, ELE 10000 μ /100V UA G	728	R54	5135-101522	RES, CBN 1/2P 100
798B	C9	5341-109J0285	CAP, ELE 10000 μ /100V N	728	R55	5135-101522	RES, CBN 1/2P 100
798	C10	5341-109J0966	CAP, ELE 10000 μ /100V UA G	728	R56	5135-101522	RES, CBN 1/2P 100
798B	C10	5341-109J0285	CAP, ELE 10000 μ /100V N	728	R57	5135-101522	RES, CBN 1/2P 100
693	C11	5345-336B0951	CAP, MINI ELE 33 μ /10V	728	R58	5135-101522	RES, CBN 1/2P 100
694	C12	5345-336F041	CAP, MINI ELE 33 μ /50V	728	R59	5135-101522	RES, CBN 1/2P 100
697	C13	5354-334593	CAP, MYL .33 μ	728	R60	5135-101522	RES, CBN 1/2P 100
697	C14	5354-334593	CAP, MYL .33 μ	728	R61	5135-101522	RES, CBN 1/2P 100
698	C17	5354-104593	CAP, MYL .1 μ	728	R62	5135-101522	RES, CBN 1/2P 100
698	C18	5354-104593	CAP, MYL .1 μ	728	R63	5135-101522	RES, CBN 1/2P 100
700	C19	5354-683K1HM	CAP, MYL .068 μ	728	R64	5135-101522	RES, CBN 1/2P 100
052A	C20	5361-6820423	CAP, CER 6800p G	728	R65	5135-101522	RES, CBN 1/2P 100
051A	C21	5352-1040962	CAP, MTL .1 μ G	728	R66	5135-101522	RES, CBN 1/2P 100
051A	C22	5352-1040962	CAP, MTL .1 μ G	728	R67	5135-101522	RES, CBN 1/2P 100
692	C35	5345-105J0962	CAP, MINI ELE 1 μ /100V	728	R68	5135-101522	RES, CBN 1/2P 100
674	C181	5345-337C041	CAP, MINI ELE 330 μ /16V	696	Δ R95	5102-1014715	RES, FUSE 100
674	C182	5345-337C041	CAP, MINI ELE 330 μ /16V	677	R181	5135-223522	RES, CBN 1/2P 22K
674	C183	5345-337C041	CAP, MINI ELE 330 μ /16V	677	R182	5135-223522	RES, CBN 1/2P 22K
674	C184	5345-337C041	CAP, MINI ELE 330 μ /16V	678	R183	5173-101583	RES, MTL 2P 100
535	C417	5345-106C041	CAP, MINI ELE 10 μ /16V	678	R184	5173-101583	RES, MTL 2P 100
535	C418	5345-106C041	CAP, MINI ELE 10 μ /16V	680	Δ R185	5102-1804713	RES, FUSE 18
539	C419	5352-4731960	CAP, MTL .047 μ	680	Δ R186	5102-1804713	RES, FUSE 18
539	C420	5352-4731960	CAP, MTL .047 μ	678	R187	5173-101583	RES, MTL 2P 100
539	C421	5352-4731960	CAP, MTL .047 μ	678	R188	5173-101583	RES, MTL 2P 100
539	C422	5352-4731960	CAP, MTL .047 μ	570	R455	5135-391522	RES, CBN 1/2P 390
535	C423	5345-106C041	CAP, MINI ELE 10 μ /16V	570	R456	5135-391522	RES, CBN 1/2P 390
535	C424	5345-106C041	CAP, MINI ELE 10 μ /16V	560	R457	5174-2215Y8	RES, MTL 1/4P 220
535	C425	5345-106C041	CAP, MINI ELE 10 μ /16V	560	R458	5174-2215Y8	RES, MTL 1/4P 220
535	C426	5345-106C041	CAP, MINI ELE 10 μ /16V	551	Δ R461	5102-1005711	RES, FUSE 10
535	C427	5345-106C041	CAP, MINI ELE 10 μ /16V	551	Δ R462	5102-1005711	RES, FUSE 10
535	C428	5345-106C041	CAP, MINI ELE 10 μ /16V	551	Δ R463	5102-1005711	RES, FUSE 10
535	C429	5345-106C041	CAP, MINI ELE 10 μ /16V	551	Δ R464	5102-1005711	RES, FUSE 10
535	C430	5345-106C041	CAP, MINI ELE 10 μ /16V	550	Δ R465	5102-1014715	RES, FUSE 100
RESISTORS							
701	R1	5171-561572	RES, MTL 1P 560	550	Δ R466	5102-1014715	RES, FUSE 100
702	R2	5171-561572	RES, MTL 1P 560	550	Δ R467	5102-1014715	RES, FUSE 100
703	R5	5135-103522	RES, CBN 1/2P 10K	550	Δ R468	5102-1014715	RES, FUSE 100
702	R6	5135-221522	RES, CBN 1/2P 220	549	Δ R469	5102-3R35116	RES, FUSE 3.3
706	R7	5232-472J16P	RES, CBN 1/6P 4.7K	549	Δ R470	5102-3R35116	RES, FUSE 3.3
707	R8	5232-334J16P	RES, CBN 1/6P 330K	549	Δ R471	5102-3R35116	RES, FUSE 3.3
708	R9	5232-104J16P	RES, CBN 1/6P 100K	549	Δ R472	5102-3R35116	RES, FUSE 3.3
708	R10	5232-104J16P	RES, CBN 1/6P 100K	571	R473	5135-150522	RES, CBN 1/2P 15
705	R11	5232-103J16P	RES, CBN 1/6P 10K	571	R474	5135-150522	RES, CBN 1/2P 15
709	R12	5232-225J16P	RES, CBN 1/6P 2.2M	571	R475	5135-150522	RES, CBN 1/2P 15
710	R13	5232-684J16P	RES, CBN 1/6P 680K	571	R476	5135-150522	RES, CBN 1/2P 15
711	R14	5232-184J16P	RES, CBN 1/6P 180K	572	R477	5135-100522	RES, CBN 1/2P 10
708	R15	5232-104J16P	RES, CBN 1/6P 100K	572	R478	5135-100522	RES, CBN 1/2P 10
712	R16	5232-473J16P	RES, CBN 1/6P 47K	572	R479	5135-100522	RES, CBN 1/2P 10
713	R17	5232-223J16P	RES, CBN 1/6P 22K	572	R480	5135-100522	RES, CBN 1/2P 10
712	R18	5232-473J16P	RES, CBN 1/6P 47K	559	R481	5174-270381	RES, MTL 1/4P 27
714	R19	5232-152J16P	RES, CBN 1/6P 1.5K	559	R482	5174-270381	RES, MTL 1/4P 27
713	R20	5232-223J16P	RES, CBN 1/6P 22K	541	R483	5275-R27671	RES, CEM 5P .27
715	R21	5232-393J16P	RES, CBN 1/6P 39K	541	R484	5275-R27671	RES, CEM 5P .27
705	R22	5232-103J16P	RES, CBN 1/6P 10K	541	R485	5275-R27671	RES, CEM 5P .27
713	R23	5232-223J16P	RES, CBN 1/6P 22K	541	R486	5275-R27671	RES, CEM 5P .27
712	R24	5232-473J16P	RES, CBN 1/6P 47K	541	R487	5275-R27671	RES, CEM 5P .27
724	R26	5232-102J16P	RES, CBN 1/6P 1K	541	R488	5275-R27671	RES, CEM 5P .27
705	R27	5232-103J16P	RES, CBN 1/6P 10K	541	R489	5275-R27671	RES, CEM 5P .27
725	R28	5232-153J16P	RES, CBN 1/6P 15K	541	R490	5275-R27671	RES, CEM 5P .27
708	R29	5232-104J16P	RES, CBN 1/6P 100K	543	R491	5171-100572	RES, MTL 1P 10
708	R30	5232-104J16P	RES, CBN 1/6P 100K	543	R492	5171-100572	RES, MTL 1P 10
726	R31	5232-823J16P	RES, CBN 1/6P 82K	542	R493	5175-100571	RES, MTL 3P 10
706	R39	5232-472J16P	RES, CBN 1/6P 4.7K	542	R494	5175-100571	RES, MTL 3P 10
				573	R495	5135-221522	RES, CBN 1/2P 220
				573	R496	5135-221522	RES, CBN 1/2P 220
				572	R503	5135-100522	RES, CBN 1/2P 10
				572	R504	5135-100522	RES, CBN 1/2P 10
				572	R505	5135-100522	RES, CBN 1/2P 10

Ser. No.	Ref. No.	Part No.	Description	Ser. No.	Ref. No.	Part No.	Description
572	R506	5135-100522	RES, CBN 1/2P 10				
559	R511	5174-270381	RES, MTL 1/4P 27	562	VR403	5101-3317674	RES, SEMI FIX 330
559	R512	5174-270381	RES, MTL 1/4P 27	562	VR404	5101-3317674	RES, SEMI FIX 330
TRANSISTORS				CONTROLS			
681	Q1	5613-2603(E)or(F)	XISTOR, NPN R	861	CN1	4443-030185	CONNECTOR
682	Q2	5611-1115(E)or(F)	XISTOR, PNP R	861	CN2	4443-030185	CONNECTOR
681	Q3	5613-2603(E)or(F)	XISTOR, NPN R	844	JL5	4242-R0404351	JUMPER LEAD
682	Q4	5611-1115(E)or(F)	XISTOR, PNP R	851	JL17	4242-R0105101	JUMPER LEAD
682	Q5	5611-1115(E)or(F)	XISTOR, PNP R	851	JL18	4242-R0105101	JUMPER LEAD
682	Q6	5611-1115(E)or(F)	XISTOR, PNP R	686	PT1	5192-100TS1	POSISTOR
681	Q7	5613-2603(E)or(F)	XISTOR, NPN R	686	PT2	5192-100TS1	POSISTOR
682	Q8	5611-1115(E)or(F)	XISTOR, PNP R	855	TM1	4214-11034	TERMINAL
683	Q10	5611-970(BL)	XISTOR, PNP R	855	TM2	4214-11034	TERMINAL
683	Q11	5611-970(BL)	XISTOR, PNP R	856	TM3	4214-11021	TERMINAL
684	Q12	5613-2240(BL)	XISTOR, NPN R	856	TM4	4214-11021	TERMINAL
668	Q181	5614-669(C)	XISTOR, NPN A	856	TM5	4214-11021	TERMINAL
670	Q182	5612-649(C)	XISTOR, PNP A	856	TM6	4214-11021	TERMINAL
524	Q429	5613-3423(O)or(Y)	XISTOR, NPN R	816	LCN101	4163-0145024	CONNECTOR W/W
524	Q430	5613-3423(O)or(Y)	XISTOR, NPN R	817	LCN102	4163-0145025	CONNECTOR W/W
52 0	Q431	5611-970(BL)	XISTOR, PNP R	818	LCN103	4163-0145026	CONNECTOR W/W
520	Q432	5611-970(BL)	XISTOR, PNP R	819	LCN104	4163-0145027	CONNECTOR W/W
510	Q433	5613-2682(P)	XISTOR, NPN R	821	LCN106	4163-0110024	CONNECTOR W/W
510	Q434	5613-2682(P)	XISTOR, NPN R	821	LCN107	4163-0110024	CONNECTOR W/W
512	Q435	5611-1142(P)	XISTOR, PNP R	057A	△	4472-7122	HOLDER, FUSE 
512	Q436	5611-1142(P)	XISTOR, PNP R	PCB-2 SPEAKER TERMINAL P.C.BOARD			
514	Q437	5611-1306A(Y)	XISTOR, PNP R	847	JL3	4242-R0403651	JUMPER LEAD
514	Q438	5611-1306A(Y)	XISTOR, PNP R	838	TM11	4214-184	TERMINAL
515	Q439	5613-3298A(Y)	XISTOR, NPN R	PCB-5 PROTECTION P.C.BOARD			
515	Q440	5613-3298A(Y)	XISTOR, NPN R	CAPACITORS			
516	Q441	5613-3907(O)or(R)	XISTOR, NPN R	761	C31	5345-107D041	CAP, MINI ELE 100μ/25V
516	Q442	5613-3907(O)or(R)	XISTOR, NPN R	762	C33	5345-476C041	CAP, MINI ELE 47μ/16V
516	Q443	5613-3907(O)or(R)	XISTOR, NPN R	RESISTORS			
516	Q444	5613-3907(O)or(R)	XISTOR, NPN R	758	△R76	5102-5604715	RES, FUSE 56
516	Q445	5613-3907(O)or(R)	XISTOR, NPN R	759	△R77	5102-2204715	RES, FUSE 22
516	Q446	5613-3907(O)or(R)	XISTOR, NPN R	760	△R78	5102-5R64715	RES, FUSE 5.6
516	Q447	5613-3907(O)or(R)	XISTOR, NPN R	DIODES			
516	Q448	5613-3907(O)or(R)	XISTOR, NPN R	757	D16	5632-S5566B	DIODE, RECT
518	Q449	5611-1516(O)or(R)	XISTOR, PNP R	757	D17	5632-S5566B	DIODE, RECT
518	Q450	5611-1516(O)or(R)	XISTOR, PNP R	MISCELLANEOUS			
518	Q451	5611-1516(O)or(R)	XISTOR, PNP R	850	JL9	4242-R0403501	JUMPER LEAD
518	Q452	5611-1516(O)or(R)	XISTOR, PNP R	857	TM7	4214-11034	TERMINAL
518	Q453	5611-1516(O)or(R)	XISTOR, PNP R	822	LCN108	4163-0110022	CONNECTOR W/W
518	Q454	5611-1516(O)or(R)	XISTOR, PNP R	823	LCN109	4163-0110021	CONNECTOR W/W
518	Q455	5611-1516(O)or(R)	XISTOR, PNP R	824	LCN110	4163-0110023	CONNECTOR W/W
518	Q456	5611-1516(O)or(R)	XISTOR, PNP R	PCB-6 REMOTE POWER P.C.BOARD			
DIODES				832	J2	4451-00177	JACK, 1P
764	△D1	5685-D5SB40	SILICON, BRIDGE	852	JL6	4242-R0404451	JUMPER LEAD
764	△D2	5685-D5SB40	SILICON, BRIDGE	834	SW4	4421-0227142	SWITCH, SLIDE
687	D3	5632-S5566B	DIODE, RECT	PCB-9 POWER LEVEL INDICATORS P.C.BOARD			
687	D4	5632-S5566B	DIODE, RECT	CAPACITORS			
689	D5	5635-HZ6A-2L	DIODE, ZENER	631	C101	5345-106C041	CAP, MINI ELE 10μ/16V
690	D6	5631-ISS133	DIODE, DET	631	C102	5345-106C041	CAP, MINI ELE 10μ/16V
687	D19	5632-S5566B	DIODE, RECT	631	C103	5345-106C041	CAP, MINI ELE 10μ/16V
672	D181	5635-HZ12B2L	DIODE, ZENER	631	C104	5345-106C041	CAP, MINI ELE 10μ/16V
672	D182	5635-HZ12B2L	DIODE, ZENER	634	C105	5345-225F041	CAP, MINI ELE 2.2μ/50V
527	D405	5632-10DF2	DIODE, RECT	634	C106	5345-225F041	CAP, MINI ELE 2.2μ/50V
527	D406	5632-10DF2	DIODE, RECT	635	C107	5345-336C041	CAP, MINI ELE 33μ/16V
527	D407	5632-10DF2	DIODE, RECT	635	C108	5345-336C041	CAP, MINI ELE 33μ/16V
527	D408	5632-10DF2	DIODE, RECT	633	C109	5345-336B0951	CAP, MINI ELE 33μ/10V
528	D409	5641-MV12YM	VARISTOR	633	C110	5345-336B0951	CAP, MINI ELE 33μ/10V
529	D410	5641-MV12YM	VARISTOR	633	C111	5345-336B0951	CAP, MINI ELE 33μ/10V
COILS				633	C112	5345-336B0951	CAP, MINI ELE 33μ/10V
530	L401	5597-45502	CORE, BEADS				
530	L402	5597-45502	CORE, BEADS				
530	L403	5597-45502	CORE, BEADS				
530	L404	5597-45502	CORE, BEADS				
530	L405	5597-45502	CORE, BEADS				
530	L406	5597-45502	CORE, BEADS				
530	L407	5597-45502	CORE, BEADS				
530	L408	5597-45502	CORE, BEADS				
540	L409	5991-7175	SPRING COIL				
540	L410	5991-7175	SPRING COIL				

Ser. No.	Ref. No.	Part No.	Description	Ser. No.	Ref. No.	Part No.	Description
631	C113	5345-106C041	CAP, MINI ELE 10 μ /16V	649	R155	5232-222J16P	RES, CBN 1/6P 2.2K
631	C114	5345-106C041	CAP, MINI ELE 10 μ /16V	649	R156	5232-222J16P	RES, CBN 1/6P 2.2K
628	C115	5345-104F041	CAP, MINI ELE .1 μ /50V	645	R157	5232-103J16P	RES, CBN 1/6P 10K
628	C116	5345-104F041	CAP, MINI ELE .1 μ /50V	656	R158	5232-225J16P	RES, CBN 1/6P 2.2M
634	C117	5345-225F041	CAP, MINI ELE 2.2 μ /50V	657	R159	5232-104J16P	RES, CBN 1/6P 100K
634	C118	5345-225F041	CAP, MINI ELE 2.2 μ /50V	657	R160	5232-104J16P	RES, CBN 1/6P 100K
630	C119	5345-474F041	CAP, MINI ELE .47 μ /50V	658	R161	5232-184J16P	RES, CBN 1/6P 180K
630	C120	5345-474F041	CAP, MINI ELE .47 μ /50V	659	R162	5232-564J16P	RES, CBN 1/6P 560K
631	C121	5345-106C041	CAP, MINI ELE 10 μ /16V	660	R163	5232-394J16P	RES, CBN 1/6P 390K
631	C122	5345-106C041	CAP, MINI ELE 10 μ /16V	653	R164	5232-472J16P	RES, CBN 1/6P 4.7K
631	C123	5345-106C041	CAP, MINI ELE 10 μ /16V	655	R165	5232-105J16P	RES, CBN 1/6P 1M
631	C124	5345-106C041	CAP, MINI ELE 10 μ /16V	655	R166	5232-105J16P	RES, CBN 1/6P 1M
632	C125	5345-226C041	CAP, MINI ELE 22 μ /16V	645	R167	5232-103J16P	RES, CBN 1/6P 10K
632	C126	5345-226C041	CAP, MINI ELE 22 μ /16V	655	R168	5232-105J16P	RES, CBN 1/6P 1M
636	C127	5345-336B041	CAP, MINI ELE 33 μ /10V	666	R169	5135-562522	RES, CBN 1/2P 5.6K
631	C129	5345-106C041	CAP, MINI ELE 10 μ /16V	655	R170	5232-105J16P	RES, CBN 1/6P 1M
631	C130	5345-106C041	CAP, MINI ELE 10 μ /16V	665	R179	5232-331J16P	RES, CBN 1/6P 330
639	C131	5354-104593	CAP, MYL .1 μ	665	R180	5232-331J16P	RES, CBN 1/6P 330
639	C132	5354-104593	CAP, MYL .1 μ	INTEGRATED CIRCUITS			
RESISTORS				621	IC101	5653-BA681A	IC, LINEAR
641	R101	5232-122J16P	RES, CBN 1/6P 1.2K	621	IC102	5653-BA681A	IC, LINEAR
641	R102	5232-122J16P	RES, CBN 1/6P 1.2K	622	IC103	5653-TA75558P	IC, LINEAR
642	R103	5232-473J16P	RES, CBN 1/6P 47K	622	IC104	5653-TA75558P	IC, LINEAR
642	R104	5232-473J16P	RES, CBN 1/6P 47K	TRANSISTORS			
643	R105	5232-102J16P	RES, CBN 1/6P 1K	624	Q101	5613-2603(E)or(F)	XISTOR, NPN R
643	R106	5232-102J16P	RES, CBN 1/6P 1K	624	Q102	5613-2603(E)or(F)	XISTOR, NPN R
640	R107	5232-123J16P	RES, CBN 1/6P 12K	624	Q103	5613-2603(E)or(F)	XISTOR, NPN R
640	R108	5232-123J16P	RES, CBN 1/6P 12K	624	Q104	5613-2603(E)or(F)	XISTOR, NPN R
644	R109	5232-101J16P	RES, CBN 1/6P 100	624	Q105	5613-2603(E)or(F)	XISTOR, NPN R
644	R110	5232-101J16P	RES, CBN 1/6P 100	624	Q106	5613-2603(E)or(F)	XISTOR, NPN R
645	R111	5232-103J16P	RES, CBN 1/6P 10K	624	Q107	5613-2603(E)or(F)	XISTOR, NPN R
645	R112	5232-103J16P	RES, CBN 1/6P 10K	624	Q108	5613-2603(E)or(F)	XISTOR, NPN R
646	R113	5232-820J16P	RES, CBN 1/6P 82	624	Q109	5613-2603(E)or(F)	XISTOR, NPN R
646	R114	5232-820J16P	RES, CBN 1/6P 82	625	Q110	5611-1115(E)or(F)	XISTOR, PNP R
645	R115	5232-103J16P	RES, CBN 1/6P 10K	626	Q111	5616-2SK364(V)or(BL)	FET, N-CH
645	R116	5232-103J16P	RES, CBN 1/6P 10K	626	Q112	5616-2SK364(V)or(BL)	FET, N-CH
647	R117	5232-152J16P	RES, CBN 1/6P 1.5K	626	Q113	5616-2SK364(V)or(BL)	FET, N-CH
647	R118	5232-152J16P	RES, CBN 1/6P 1.5K	626	Q114	5616-2SK364(V)or(BL)	FET, N-CH
648	R119	5232-333J16P	RES, CBN 1/6P 33K	624	Q115	5613-2603(E)or(F)	XISTOR, NPN R
648	R120	5232-333J16P	RES, CBN 1/6P 33K	DIODES			
649	R121	5232-222J16P	RES, CBN 1/6P 2.2K	629	D101	5631-1SS133	DIODE, DET
649	R122	5232-222J16P	RES, CBN 1/6P 2.2K	629	D102	5631-1SS133	DIODE, DET
667	R123	5174-474381	RES, MTL 1/4P 470K	629	D103	5631-1SS133	DIODE, DET
667	R124	5174-474381	RES, MTL 1/4P 470K	629	D104	5631-1SS133	DIODE, DET
664	R125	5232-563J16P	RES, CBN 1/6P 56K	629	D105	5631-1SS133	DIODE, DET
664	R126	5232-563J16P	RES, CBN 1/6P 56K	629	D106	5631-1SS133	DIODE, DET
663	R127	5232-124J16P	RES, CBN 1/6P 120K	805	D107	5637-GL5HD10	LED
663	R128	5232-124J16P	RES, CBN 1/6P 120K	805	D108	5637-GL5HD10	LED
651	R129	5232-563J16P	RES, CBN 1/6P 56K	807	D109	5637-GL5HY10	LED
651	R130	5232-563J16P	RES, CBN 1/6P 56K	807	D110	5637-GL5HY10	LED
655	R131	5232-105J16P	RES, CBN 1/6P 1M	807	D111	5637-GL5HY10	LED
655	R132	5232-105J16P	RES, CBN 1/6P 1M	807	D112	5637-GL5HY10	LED
645	R133	5232-103J16P	RES, CBN 1/6P 10K	807	D113	5637-GL5HY10	LED
645	R134	5232-103J16P	RES, CBN 1/6P 10K	807	D114	5637-GL5HY10	LED
652	R135	5232-224J16P	RES, CBN 1/6P 220K	806	D115	5637-GL5EG21	LED
652	R136	5232-224J16P	RES, CBN 1/6P 220K	806	D116	5637-GL5EG21	LED
661	R137	5232-154J16P	RES, CBN 1/6P 150K	806	D117	5637-GL5EG21	LED
661	R138	5232-154J16P	RES, CBN 1/6P 150K	806	D118	5637-GL5EG21	LED
642	R139	5232-473J16P	RES, CBN 1/6P 47K	806	D119	5637-GL5EG21	LED
642	R140	5232-473J16P	RES, CBN 1/6P 47K	806	D120	5637-GL5EG21	LED
643	R141	5232-102J16P	RES, CBN 1/6P 1K	806	D121	5637-GL5EG21	LED
643	R142	5232-102J16P	RES, CBN 1/6P 1K	806	D122	5637-GL5EG21	LED
640	R143	5232-123J16P	RES, CBN 1/6P 12K	806	D123	5637-GL5EG21	LED
640	R144	5232-123J16P	RES, CBN 1/6P 12K	806	D124	5637-GL5EG21	LED
644	R145	5232-101J16P	RES, CBN 1/6P 100	629	D125	5631-1SS133	DIODE, DET
644	R146	5232-101J16P	RES, CBN 1/6P 100	629	D126	5631-1SS133	DIODE, DET
662	R147	5232-223J16P	RES, CBN 1/6P 22K	CONTROLS			
662	R148	5232-223J16P	RES, CBN 1/6P 22K	638	VR101	5101-30401933300K	RES, SEMI FIX
662	R149	5232-223J16P	RES, CBN 1/6P 22K	638	VR102	5101-30401933300K	RES, SEMI FIX
662	R150	5232-223J16P	RES, CBN 1/6P 22K	637	VR103	5101-50171920500	RES, SEMI FIX
654	R151	5232-561J16P	RES, CBN 1/6P 560	637	VR104	5101-50171920500	RES, SEMI FIX
654	R152	5232-561J16P	RES, CBN 1/6P 560	MISCELLANEOUS			
648	R153	5232-333J16P	RES, CBN 1/6P 33K	862	CN3	4443-030185	CONNECTOR
648	R154	5232-333J16P	RES, CBN 1/6P 33K	862	CN4	4443-030185	CONNECTOR

Ser. No.	Ref. No.	Part No.	Description	Ser. No.	Ref. No.	Part No.	Description
863	CN5	4443-040185	CONNECTOR	554	R423	5174-431381	RES, MTL 1/4P 430
853	JL19	4242-R0103251	JUMPER LEAD	554	R424	5174-431381	RES, MTL 1/4P 430
810	SW7	4431-02067179	SWITCH, PUSH	555	R425	5174-220381	RES, MTL 1/4P 22
PCB-10 PRE DRIVER P.C.BOARD							
CAPACITORS							
699	C15	5354-104593	CAP, MYL .1 μ	556	R426	5174-220381	RES, MTL 1/4P 22
699	C16	5354-104593	CAP, MYL .1 μ	547	Δ R427	5102-1024715	RES, FUSE 1K
531	C401	5345-107B0951	CAP, MINI ELE 100 μ /10V	547	Δ R428	5102-1024715	RES, FUSE 1K
531	C402	5345-107B0951	CAP, MINI ELE 100 μ /10V	547	Δ R429	5102-1024715	RES, FUSE 1K
536	C403	5353-680534	CAP, MCA 68p	547	Δ R430	5102-1024715	RES, FUSE 1K
055A	C403	5359-5615851	CAP, PPP 560p	566	R431	5135-222522	RES, CBN 1/2P 2.2K
536	C404	5353-680534	CAP, MCA 68p	566	R432	5135-222522	RES, CBN 1/2P 2.2K
055A	C404	5359-5615851	CAP, PPP 560p	556	R433	5174-223381	RES, MTL 1/4P 22K
532	C405	5345-337C041	CAP, MINI ELE 330 μ /16V	556	R434	5174-223381	RES, MTL 1/4P 22K
532	C406	5345-337C041	CAP, MINI ELE 330 μ /16V	568	R435	5135-273522	RES, CBN 1/2P 27K
537	C407	5353-040934	CAP, MCA 4p	568	R436	5135-273522	RES, CBN 1/2P 27K
537	C408	5353-040934	CAP, MCA 4p	564	R437	5135-223522	RES, CBN 1/2P 22K
536	C409	5353-680534	CAP, MCA 68p	564	R438	5135-223522	RES, CBN 1/2P 22K
536	C410	5353-680534	CAP, MCA 68p	557	R439	5174-222381	RES, MTL 1/4P 2.2K
538	C411	5345-476B0951	CAP, MINI ELE 47 μ /10V	557	R440	5174-222381	RES, MTL 1/4P 2.2K
538	C412	5345-476B0951	CAP, MINI ELE 47 μ /10V	557	R441	5174-222381	RES, MTL 1/4P 2.2K
534	C413	5345-477J0962	CAP, MINI ELE 470 μ /100V	557	R442	5174-222381	RES, MTL 1/4P 2.2K
534B	C413	5345-477J0266	CAP, MINI ELE 470 μ /100V	548	Δ R443	5102-1214715	RES, FUSE 120
534	C414	5345-477J0962	CAP, MINI ELE 470 μ /100V	548	Δ R444	5102-1214715	RES, FUSE 120
534B	C414	5345-477J0266	CAP, MINI ELE 470 μ /100V	548	Δ R445	5102-1214715	RES, FUSE 120
534	C415	5345-477J0962	CAP, MINI ELE 470 μ /100V	548	Δ R446	5102-1214715	RES, FUSE 120
534B	C415	5345-477J0266	CAP, MINI ELE 470 μ /100V	569	R447	5135-123522	RES, CBN 1/2P 12K
534	C416	5345-477J0266	CAP, MINI ELE 470 μ /100V	569	R448	5135-123522	RES, CBN 1/2P 12K
534B	C416	5345-477J0266	CAP, MINI ELE 470 μ /100V	569	R449	5135-123522	RES, CBN 1/2P 12K
533	C431	5345-106C041	CAP, MINI ELE 10 μ /16V	569	R450	5135-123522	RES, CBN 1/2P 12K
533	C432	5345-106C041	CAP, MINI ELE 10 μ /16V	548	Δ R451	5102-1214715	RES, FUSE 120
532	C437	5345-337C041	CAP, MINI ELE 330 μ /16V	548	Δ R452	5102-1214715	RES, FUSE 120
532	C438	5345-337C041	CAP, MINI ELE 330 μ /16V	548	Δ R453	5102-1214715	RES, FUSE 120
544	C441	5354-103K1HM	CAP, MYL .01 μ	548	Δ R454	5102-1214715	RES, FUSE 120
544	C442	5354-103K1HM	CAP, MYL .01 μ	558	R459	5174-131381	RES, MTL 1/4P 130
544	C443	5354-103K1HM	CAP, MYL .01 μ	558	R460	5174-131381	RES, MTL 1/4P 130
544	C444	5354-103K1HM	CAP, MYL .01 μ	564	R497	5135-223522	RES, CBN 1/2P 22K
RESISTORS							
575	R37	5135-105522	RES, CBN 1/2P 1M	564	R498	5135-223522	RES, CBN 1/2P 22K
575	R38	5135-105522	RES, CBN 1/2P 1M	565	R499	5135-221522	RES, CBN 1/2P 220
574	R41	5135-223522	RES, CBN 1/2P 22K	565	R500	5135-221522	RES, CBN 1/2P 220
574	R42	5135-223522	RES, CBN 1/2P 22K	565	R501	5135-221522	RES, CBN 1/2P 220
577	R43	5135-473522	RES, CBN 1/2P 47K	565	R502	5135-221522	RES, CBN 1/2P 220
577	R44	5135-473522	RES, CBN 1/2P 47K	566	R507	5135-222522	RES, CBN 1/2P 2.2K
578	R45	5135-104522	RES, CBN 1/2P 100K	553	R509	5174-181381	RES, MTL 1/4P 180
578	R46	5135-104522	RES, CBN 1/2P 100K	566	R517	5135-222522	RES, CBN 1/2P 2.2K
563	R401	5135-102522	RES, CBN 1/2P 1K	566	R518	5135-222522	RES, CBN 1/2P 2.2K
566A	R401	5135-222522	RES, CBN 1/2P 2.2K	552	R519	5174-241381	RES, MTL 1/4P 240
563	R402	5135-102522	RES, CBN 1/2P 1K	563A	R519	5135-331522	RES, CBN 1/2P 330
566A	R402	5135-222522	RES, CBN 1/2P 2.2K	552	R520	5174-241381	RES, MTL 1/4P 240
556	R403	5174-223381	RES, MTL 1/4P 22K	563A	R520	5135-331522	RES, CBN 1/2P 330
556	R404	5174-223381	RES, MTL 1/4P 22K	566	R521	5135-222522	RES, CBN 1/2P 2.2K
564	R405	5135-223522	RES, CBN 1/2P 22K	566	R522	5135-222522	RES, CBN 1/2P 2.2K
564	R406	5135-223522	RES, CBN 1/2P 22K	566	R523	5135-222522	RES, CBN 1/2P 2.2K
547	Δ R407	5102-1024715	RES, FUSE 1K	566	R524	5135-222522	RES, CBN 1/2P 2.2K
547	Δ R408	5102-1024715	RES, FUSE 1K	566	R525	5135-222522	RES, CBN 1/2P 2.2K
547	Δ R409	5102-1024715	RES, FUSE 1K	566	R526	5135-222522	RES, CBN 1/2P 2.2K
547	Δ R410	5102-1024715	RES, FUSE 1K	566	R527	5135-222522	RES, CBN 1/2P 2.2K
565	R411	5135-221522	RES, CBN 1/2P 220	566	R528	5135-222522	RES, CBN 1/2P 2.2K
565	R412	5135-221522	RES, CBN 1/2P 220	564	R529	5135-223522	RES, CBN 1/2P 22K
565	R413	5135-221522	RES, CBN 1/2P 220	564	R530	5135-223522	RES, CBN 1/2P 22K
565	R414	5135-221522	RES, CBN 1/2P 220	576	R535	5135-103522	RES, CBN 1/2P 10K
566	R415	5135-222522	RES, CBN 1/2P 2.2K	576	R536	5135-103522	RES, CBN 1/2P 10K
566	R416	5135-222522	RES, CBN 1/2P 2.2K	576	R537	5135-103522	RES, CBN 1/2P 10K
552	R417	5174-241381	RES, MTL 1/4P 240	576	R538	5135-103522	RES, CBN 1/2P 10K
563A	R417	5135-331522	RES, CBN 1/2P 330	574	R539	5135-223522	RES, CBN 1/2P 22K
552	R418	5174-241381	RES, MTL 1/4P 240	574	R540	5135-223522	RES, CBN 1/2P 22K
563A	R418	5135-331522	RES, CBN 1/2P 330	574	R541	5135-223522	RES, CBN 1/2P 22K
567	R419	5135-563522	RES, CBN 1/2P 56K	574	R542	5135-223522	RES, CBN 1/2P 22K
567	R420	5135-563522	RES, CBN 1/2P 56K	TRANSISTORS			
564	R421	5135-223522	RES, CBN 1/2P 22K	501	Q401	5616-2SK364(V)or(BL)	FET, N-CH
564	R422	5135-223522	RES, CBN 1/2P 22K	501	Q402	5616-2SK364(V)or(BL)	FET, N-CH
				502	Q403	5613-2240(BL)	XISTOR, NPN R
				502	Q404	5613-2240(BL)	XISTOR, NPN R
				502	Q405	5613-2240(BL)	XISTOR, NPN R
				502	Q406	5613-2240(BL)	XISTOR, NPN R
				503	Q407	5613-2603(E)or(F)	XISTOR, NPN R

Ser. No.	Ref. No.	Part No.	Description
503	Q408	5613-2603(E)or(F)	XISTOR, NPN R
503	Q409	5613-2603(E)or(F)	XISTOR, NPN R
503	Q410	5613-2603(E)or(F)	XISTOR, NPN R
508	Q411	5611-970(BL)	XISTOR, PNP R
508	Q412	5611-970(BL)	XISTOR, PNP R
506	Q413	5613-2320L(F)	XISTOR, NPN R
506	Q414	5613-2320L(F)	XISTOR, NPN R
507	Q415	5611-999L(F)	XISTOR, PNP R
507	Q416	5611-999L(F)	XISTOR, PNP R
508	Q417	5611-970(BL)	XISTOR, PNP R
508	Q418	5611-970(BL)	XISTOR, PNP R
509	Q419	5613-3334	XISTOR, NPN R
509	Q420	5613-3334	XISTOR, NPN R
504	Q421	5611-1142(P)	XISTOR, PNP R
504	Q422	5611-1142(P)	XISTOR, PNP R
522	Q423	5613-2682(P)	XISTOR, NPN R
522	Q424	5613-2682(P)	XISTOR, NPN R
504	Q425	5611-1142(P)	XISTOR, PNP R
504	Q426	5611-1142(P)	XISTOR, PNP R
522	Q427	5613-2682(P)	XISTOR, NPN R
522	Q428	5613-2682(P)	XISTOR, NPN R
508	Q457	5611-970(BL)	XISTOR, PNP R
508	Q458	5611-970(BL)	XISTOR, PNP R
521	Q459	5611-1115(E)or(F)	XISTOR, PNP R
521	Q460	5611-1115(E)or(F)	XISTOR, PNP R
521	Q461	5611-1115(E)or(F)	XISTOR, PNP R
521	Q462	5611-1115(E)or(F)	XISTOR, PNP R
502	Q463	5613-2240(BL)	XISTOR, NPN R
502	Q464	5613-2240(BL)	XISTOR, NPN R
502	Q465	5613-2240(BL)	XISTOR, NPN R
502	Q466	5613-2240(BL)	XISTOR, NPN R
508	Q467	5611-970(BL)	XISTOR, PNP R
508	Q468	5611-970(BL)	XISTOR, PNP R
508	Q469	5611-970(BL)	XISTOR, PNP R
508	Q470	5611-970(BL)	XISTOR, PNP R
DIODES			
526	D401	5635-HZ12B2L	DIODE, ZENER
526	D402	5635-HZ12B2L	DIODE, ZENER
526	D403	5635-HZ12B2L	DIODE, ZENER
526	D404	5635-HZ12B2L	DIODE, ZENER
525	D411	5635-HZ22-2L	DIODE, ZENER
525	D412	5635-HZ22-2L	DIODE, ZENER
525	D413	5635-HZ22-2L	DIODE, ZENER
525	D414	5635-HZ22-2L	DIODE, ZENER
CONTROLS			
561	VR401	5101-4738775 47K	RES, SEMI FIX
561	VR402	5101-4738775 47K	RES, SEMI FIX
MISCELLANEOUS			
879	CN10	4443-047175	CONNECTOR
879	CN11	4443-047175	CONNECTOR
879	CN12	4443-047175	CONNECTOR
879	CN13	4443-047175	CONNECTOR
880	CN14	4443-067175	CONNECTOR
858	TM8	4214-11031	TERMINAL

PCB-11 INPUT JACK P.C.BOARD

Ser. No.	Ref. No.	Part No.	Description
CAPACITORS			
599	C81	5345-107B0951	CAP, MINI ELE 100μ/10V
598	C82	5353-680534	CAP, MCA 68p UA N
598A	C82	5359-1025851	CAP, PPP 1000p G
600	C83	5345-228A0952	CAP, MINI ELE 2200μ/6.3V
600	C84	5345-228A0952	CAP, MINI ELE 2200μ/6.3V
613	C85	5345-337C041	CAP, MINI ELE 330μ/16V
613	C86	5345-337C041	CAP, MINI ELE 330μ/16V
613	C87	5345-337C041	CAP, MINI ELE 330μ/16V
613	C88	5345-337C041	CAP, MINI ELE 330μ/16V
597	C89	5354-104593	CAP, MYL .1μ
053A	C90	5359-4715851	CAP, PPP 470p G
053A	C91	5359-4715851	CAP, PPP 470p G
RESISTORS			
602	R81	5232-331J16P	RES, CBN 1/6P 330 UA N
602A	R81	5232-222J16P	RES, CBN 1/6P 2.2K G

Ser. No.	Ref. No.	Part No.	Description
603	R82	5232-224J16P	RES, CBN 1/6P 220K
604	R83	5232-471J16P	RES, CBN 1/6P 470
604	R84	5232-471J16P	RES, CBN 1/6P 470
605	R85	5232-104J16P	RES, CBN 1/6P 100K
606	R86	5232-105J16P	RES, CBN 1/6P 1M
607	R88	5232-221J16P	RES, CBN 1/6P 220
615	ΔR89	5102-1024715	RES, FUSE 1K
615	ΔR90	5102-1024715	RES, FUSE 1K
617	R91	5135-223522	RES, CBN 1/2P 22K
617	R92	5135-223522	RES, CBN 1/2P 22K
608	R93	5232-472J16P	RES, CBN 1/6P 4.7K
608	R94	5232-472J16P	RES, CBN 1/6P 4.7K
TRANSISTORS			
591	Q81	5611-970(BL)	XISTOR, PNP R
592	Q82	5613-2240(BL)	XISTOR, NPN R
609	Q85	5614-667(C)	XISTOR, NPN A
610	Q86	5612-647(C)	XISTOR, PNP A
595	Q87	5616-25K364(V)or(BL)	FET, N-CH
DIODES			
611	D81	5635-HZ15-1L	DIODE, ZENER
611	D82	5635-HZ15-1L	DIODE, ZENER
MISCELLANEOUS			
831	J1	4482-7135	PIN JACK, 2P
846	JL2	4242-R0403251	JUMPER LEAD
835	SW6	4421-0427226	SWITCH, SLIDE
859	TM9	4214-11031	TERMINAL
820	LCN105	4163-0125020	CONNECTOR W/W

PCB-12 RELAY P.C.BOARD

Ser. No.	Ref. No.	Part No.	Description
CAPACITORS			
789	C1	5352-1030961	CAP, MTL .01μ UA N
789A	C1	5352-1030958	CAP, MTL .01μ G
789	C2	5352-1030961	CAP, MTL .01μ UA N
789A	C2	5352-1030958	CAP, MTL .01μ G
782	C201	5345-477D041	CAP, MINI ELE 470μ/25V
783	C202	5345-227B041	CAP, MINI ELE 220μ/10V
783	C203	5345-227B041	CAP, MINI ELE 220μ/10V
RESISTORS			
791	R201	5232-102J16P	RES, CBN 1/6P 1K
785	ΔR202	5102-1004715	RES, FUSE 10
792	R203	5232-472J16P	RES, CBN 1/6P 4.7K
793	R204	5232-470J16P	RES, CBN 1/6P 47
794	R205	5232-561J16P	RES, CBN 1/6P 560
784	R206	5135-223522	RES, CBN 1/2P 22K
795	R207	5232-223J16P	RES, CBN 1/6P 22K
795	R208	5232-223J16P	RES, CBN 1/6P 22K
786	ΔR209	5102-3R35116	RES, FUSE 3.3
797	R210	5232-104J16P	RES, CBN 1/6P 100K
INTEGRATED CIRCUITS			
771	IC201	5654-TC4027BP	IC, DIGITAL
TRANSISTORS			
773	Q201	5613-2603(E)or(F)	XISTOR, NPN R
773	Q202	5613-2603(E)or(F)	XISTOR, NPN R
774	Q203	5614-667(C)	XISTOR, NPN A
774	Q204	5614-667(C)	XISTOR, NPN A
DIODES			
777	D201	5632-S5566B	DIODE, RECT
778	D202	5631-1S2473	DIODE, DET
780	D203	5635-HZ9C-2L	DIODE, ZENER
MISCELLANEOUS			
790	ΔT3	5584-702550	XFORMER, POWER UA
790A	ΔT3	5584-701550	XFORMER, POWER G
790B	ΔT3	5584-703550	XFORMER, POWER N
864	CN6	4443-030185	CONNECTOR
866	CN7	4443-040185	CONNECTOR
864	CN8	4443-030185	CONNECTOR
788	RL1	4331-20120138	RELAY, DC
796	TM12	4214-122	TERMINAL
796	TM13	4214-122	TERMINAL
796	TM14	4214-122	TERMINAL

Ser. No.	Ref. No.	Part No.	Description
796	TM15	4214-122	TERMINAL
800	△	4472-7113	HOLDER, FUSE UA N
800A	△	4472-7122	HOLDER, FUSE G

PCB-13 LED P.C.BOARD

CAPACITORS			
051B	C133	5345-106C0951	CAP, MINI ELE 10μ/16V N
051B	C134	5345-106C0951	CAP, MINI ELE 10μ/16V N
051B	C135	5345-106C0951	CAP, MINI ELE 10μ/16V N
RESISTORS			
752	R71	5135-271522	RES, CBN 1/2P 270
753	R72	5135-153522	RES, CBN 1/2P 15K
748	R73	5232-332J16P	RES, CBN 1/6P 3.3K
749	R74	5232-391J16P	RES, CBN 1/6P 390
749	R75	5232-391J16P	RES, CBN 1/6P 390
733	R171	5232-103J16P	RES, CBN 1/6P 10K
734	R172	5232-332J16P	RES, CBN 1/6P 3.3K
738	R173	5232-271J16P	RES, CBN 1/6P 270
736	R174	5232-102J16P	RES, CBN 1/6P 1K
737	R175	5232-472J16P	RES, CBN 1/6P 4.7K
739	R176	5232-122J16P	RES, CBN 1/6P 1.2K
735	R177	5232-391J16P	RES, CBN 1/6P 390
735	R178	5232-391J16P	RES, CBN 1/6P 390
TRANSISTORS			
741	Q13	5611-1115(E)or(F)	XISTOR, PNP R
729	Q116	5611-1115(E)or(F)	XISTOR, PNP R
729	Q117	5611-1115(E)or(F)	XISTOR, PNP R

DIODES			
801	D7	5637-GL5EG21	LED
802	D8	5637-GL5HD10	LED
802	D9	5637-GL5HD10	LED
802	D10	5637-GL5HD10	LED
802	D11	5637-GL5HD10	LED
802	D12	5637-GL5HD10	LED
802	D13	5637-GL5HD10	LED
744	D14	5635-HZ7B-2L	DIODE, ZENER
804	D204	5637-GL5HY10	LED
804	D205	5637-GL5HY10	LED
MISCELLANEOUS			
865	CN9	4443-040185	CONNECTOR
845	JL4	4242-R0403551	JUMPER LEAD
848	JL8	4242-R0403101	JUMPER LEAD
849	JL16	4242-R0403181	JUMPER LEAD

PCB-14 POWER SWITCH P.C.BOARD

843	JL7	4242-R0404101	JUMPER LEAD
811	△SW1	4431-A027170	SWITCH, PUSH

CHASSIS MISCELLANEOUS

799	△F1	5732-502028	FUSE UA
799A	△F1	5732-252030	FUSE G
799B	△F1	5732-602056	FUSE N
799	△F2	5732-502028	FUSE UA
799A	△F2	5732-252030	FUSE G
799B	△F2	5732-602056	FUSE N
056A	△F3	5732-632030	FUSE G
056A	△F4	5732-632030	FUSE G
056A	△F5	5732-632030	FUSE G
056A	△F6	5732-632030	FUSE G
787	△T1	5584-701555	XFORMER, POWER UA
787A	△T1	5584-701556	XFORMER, POWER G
787B	△T1	5584-702556	XFORMER, POWER N
787	△T2	5584-701555	XFORMER, POWER UA
787A	△T2	5584-701556	XFORMER, POWER G
787B	△T2	5584-702556	XFORMER, POWER N
052A	△SW2	4411-1047112	SWITCH, ROTARY G
836	SW8	4421-0227230	SWITCH, SLIDE
836	SW9	4421-0227230	SWITCH, SLIDE
841	△P1	4161-71154	CORD W/PLUG, POWER UA
841A	△P1	4161-71150	CORD W/PLUG, POWER G

Ser. No.	Ref. No.	Part No.	Description
841B	△P1	4161-72145	CORD W/PLUG, POWER N
249	LUG1	4211-5005	LUG, GND UA N
839		4442-14	PIN PLUG, SHORT PIN
905		4161-71174	CORD W/PLUG, CONNECT
187		2240-385	HOLDER, WIRING

PACKAGE PARTS LIST

021A	1756-03108	LABEL, INT G
021B	1756-03113	LABEL N
022A	1756-06303	LABEL, 220V/50Hz G
023A	1756-01443	LABEL G
025A	1119-026	ATTACH SHEET, FTZ SHEET G
105	1111-J90195	OWNER GUIDE, UL UA
106	1111-J30257	OWNER GUIDE, OG UA
106A	1111-J30256	OWNER GUIDE, OG G
106B	1111-J2034	OWNER GUIDE, OG N
107	1113-717005	OWNER CARD, REPLY CARD UA
107B	1113-OC	OWNER CARD, REPLY CARD N
108	1119-057	ATTACH SHEET, WARRANTY UA
108B	1116-GC	ATTACH SHEET, WARRANTY N
109	1119-0137	ATTACH SHEET
111	1241-C12732	POLYETHY BAG, OG UA G
111B	1241-C12729	POLYETHY BAG, OG N
122	1221-717198	CARTON BOX
123	1222-7307	CUSHION, R
124	1222-7308	CUSHION, L
125	1223-11747	SOFT SHEET, SET
126	1223-11115	SOFT SHEET, AC CORD
127	1241-C1494	POLYETHY BAG, SET

ABBREVIATIONS IN PARTS LIST

CAPACITORS	RESISTORS
CAP, MINI ELE : Electrolytic	RES, CBN 1/6P : Carbon 1/6W
CAP, CER : Ceramic	RES, FUSE : Fuse
CAP, PPP : Polypropylene	RES, CEM 5P : Cement 5W
CAP, MYL : Mylar	RES, MTL 1P : Metal 1W
CAP, MCA : Mica	2.2K : 2.2kΩ
CAP, MINI BP : Bipolar	220 : 220Ω
CAP, ELE BP : Electrolytic Bipolar	TRANSISTORS
470μ : 470μF	XISTOR : Transistor
6800p : 6800pF	FET : Field Effect Transistor
.047μ : 0.047μF	CONTROLS
	RES, V CBN : Variable Carbon Resistor

NOTE

 SAFETY RELATED COMPONENT. USE ONLY EXACT REPLACEMENT PART AS SPECIFIED.

IC BLOCK DIAGRAM

BA681A : IC101, 102

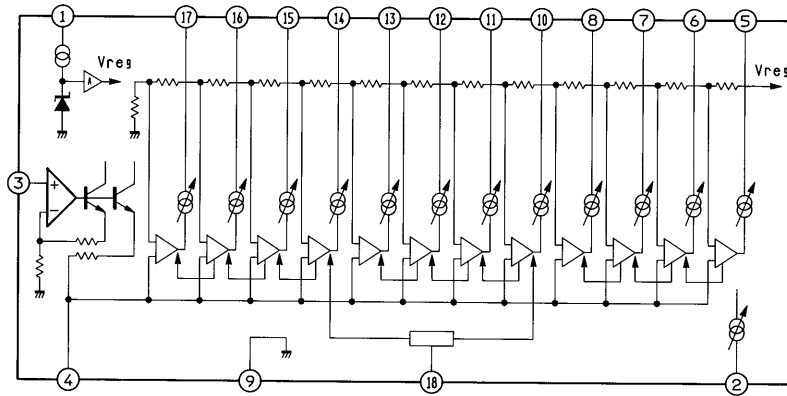

TA75558P : IC103, 104

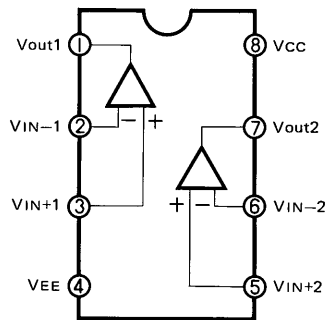

TC4027BP : IC201

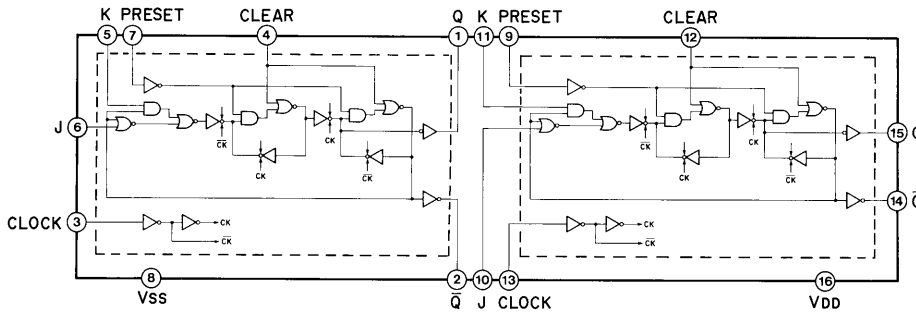

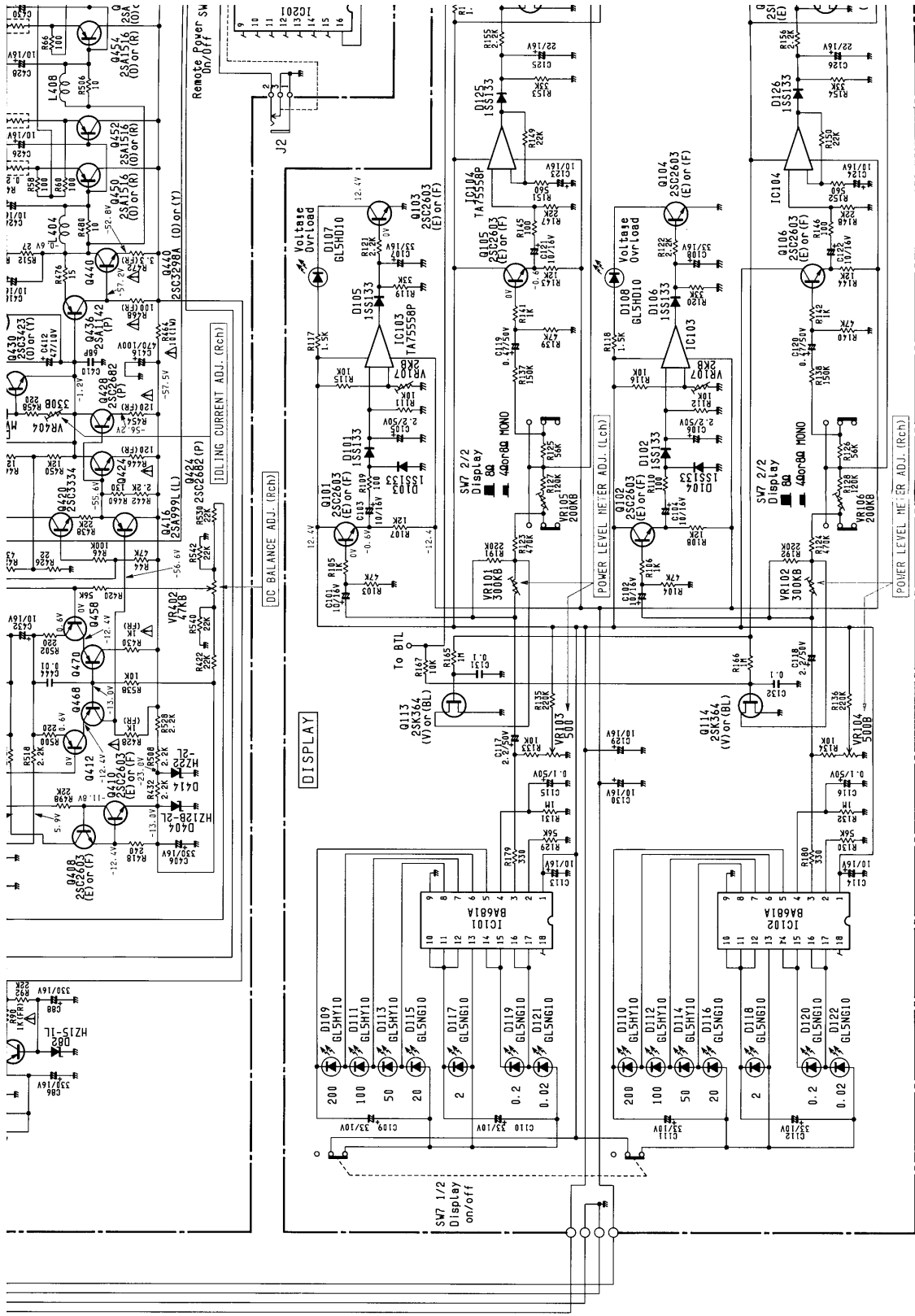

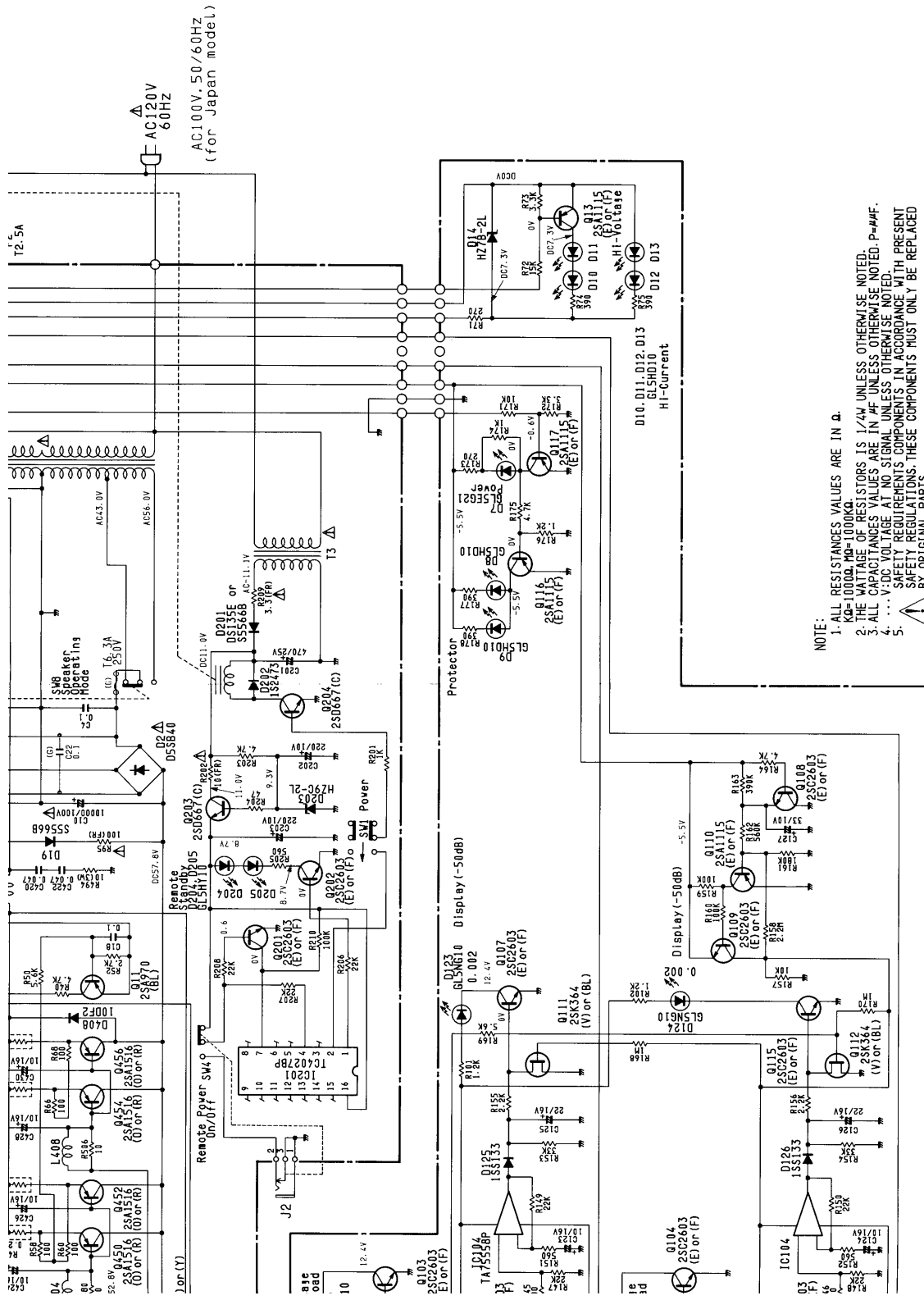

NOTE:

1. ALL RESISTANCE VALUES ARE IN Ω .
2. $K\Omega = 1000, M\Omega = 1000K\Omega$.
3. THE VOLTAGE OF RESISTORS IS 1/4W UNLESS OTHERWISE NOTED.
4. ALL CAPACITANCE VALUES ARE IN μF UNLESS OTHERWISE NOTED. P=44F.
5. ... TO BE REPLACED BY ORIGINAL PARTS.

BY ORIGINAL PARTS.

