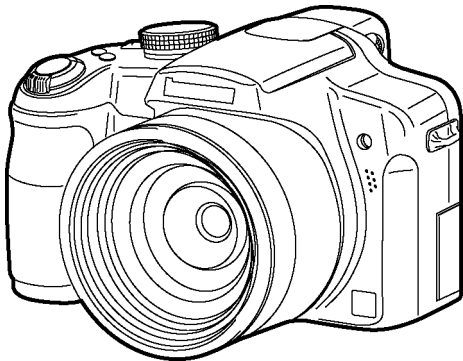


Service Manual

Digital Camera

LUMIX
LEICA
DC VARIO-ELMARIT



Model No. **DMC-FZ28P**
DMC-FZ28PC
DMC-FZ28PL
DMC-FZ28EB
DMC-FZ28EE
DMC-FZ28EF
DMC-FZ28EG
DMC-FZ28E
DMC-FZ28GC
DMC-FZ28GD
DMC-FZ28GK
DMC-FZ28GN
DMC-FZ28GT
DMC-FZ28GJ
DMC-FZ28SG

VOL.1

Colours

(S).....Silver Type (only DMC-FZ28P/PC/EB/
EE/EF/EG/E/GC/SG)
(K).....Black Type

WARNING

This service information is designed for experienced repair technicians only and is not designed for use by the general public. It does not contain warnings or cautions to advise non-technical individuals of potential dangers in attempting to service a product. Products powered by electricity should be serviced or repaired only by experienced professional technicians. Any attempt to service or repair the product or products dealt with in this service information by anyone else could result in serious injury or death.

Panasonic[®]

© 2008 Matsushita Electric Industrial Co., Ltd. All rights reserved. Unauthorized copying and distribution is a violation of law.

TABLE OF CONTENTS

	PAGE	PAGE
1 Safety Precautions	3	
1.1. General Guidelines	3	
1.2. Leakage Current Cold Check	3	
1.3. Leakage Current Hot Check (See Figure 1).....	3	
1.4. How to Discharge the Capacitor on Main PCB	4	
2 Warning	5	
2.1. Prevention of Electrostatic Discharge (ESD) to Electrostatic Sensitive (ES) Devices	5	
2.2. How to Recycle the Lithium Ion Battery (U.S. Only).....	5	
2.3. Caution for AC Cord (For EB/GC/SG)	6	
2.4. How to Replace the Lithium Battery.....	7	
3 Service Navigation	8	
3.1. Introduction	8	
3.2. General Description About Lead Free Solder (PbF)	8	
3.3. Important Notice 1:(Other than U.S.A. and Canadian Market)	8	
3.4. How to Define the Model Suffix (NTSC or PAL model)	9	
4 Specifications	13	
5 Location of Controls and Components	16	
6 Service Mode	19	
6.1. Error Code Memory Function	19	
7 Service Fixture & Tools	23	
7.1. Service Fixture and Tools	23	
7.2. Clean Box	24	
7.3. When Replacing the Main PCB	24	
7.4. Service Position	24	
8 Disassembly and Assembly Instructions	26	
8.1. Disassembly Flow Chart.....	26	
8.2. PCB Location.....	26	
8.3. Disassembly Procedure	27	
8.4. Disassembly/Assembly Procedure for the Lens	32	
8.5. Removal of the CCD Unit	36	
9 Measurements and Adjustments	37	
9.1. Matrix Chart for Replaced Part and Necessary Adjustment.....	37	
10 Maintenance	39	
10.1. Cleaning Lens, Viewfinder and LCD Panel.....	39	

1 Safety Precautions

1.1. General Guidelines

1. IMPORTANT SAFETY NOTICE

There are special components used in this equipment which are important for safety. These parts are marked by \triangle in the Schematic Diagrams, Circuit Board Layout, Exploded Views and Replacement Parts List. It is essential that these critical parts should be replaced with manufacturer's specified parts to prevent X-RADIATION, shock fire, or other hazards. Do not modify the original design without permission of manufacturer.

2. An Isolation Transformer should always be used during the servicing of AC Adaptor whose chassis is not isolated from the AC power line. Use a transformer of adequate power rating as this protects the technician from accidents resulting in personal injury from electrical shocks. It will also protect AC Adaptor from being damaged by accidental shorting that may occur during servicing.
3. When servicing, observe the original lead dress. If a short circuit is found, replace all parts which have been overheated or damaged by the short circuit.
4. After servicing, see to it that all the protective devices such as insulation barriers, insulation papers shields are properly installed.
5. After servicing, make the following leakage current checks to prevent the customer from being exposed to shock hazards.

1.2. Leakage Current Cold Check

1. Unplug the AC cord and connect a jumper between the two prongs on the plug.
2. Measure the resistance value, with an ohmmeter, between the jumpered AC plug and each exposed metallic cabinet part on the equipment such as screwheads, connectors, control shafts, etc. When the exposed metallic part has a return path to the chassis, the reading should be between $1M\Omega$ and $5.2M\Omega$. When the exposed metal does not have a return path to the chassis, the reading must be infinity.

1.3. Leakage Current Hot Check (See Figure 1)

1. Plug the AC cord directly into the AC outlet. Do not use an isolation transformer for this check.
2. Connect a $1.5k\Omega$, 10 W resistor, in parallel with a $0.15\mu F$ capacitor, between each exposed metallic part on the set and a good earth ground, as shown in Figure 1.
3. Use an AC voltmeter, with 1 $k\Omega/V$ or more sensitivity, to measure the potential across the resistor.
4. Check each exposed metallic part, and measure the voltage at each point.
5. Reverse the AC plug in the AC outlet and repeat each of the above measurements.
6. The potential at any point should not exceed 0.75 V RMS. A leakage current tester (Simpson Model 229 or equivalent) may be used to make the hot checks, leakage current must not exceed 1/2 mA. In case a measurement is outside of the limits specified, there is a possibility of a shock hazard, and the equipment should be repaired and rechecked before it is returned to the customer.

Hot-Check Circuit

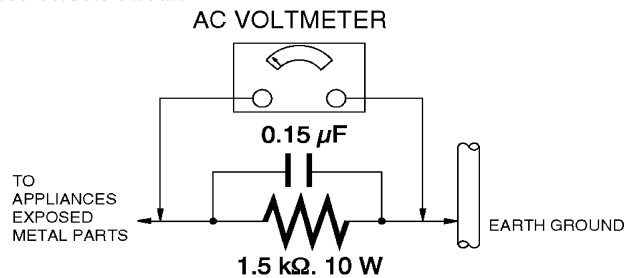


Figure 1

1.4. How to Discharge the Capacitor on Main PCB

- This unit equipped with two pieces of capacitors as flash charging capacitors.
“Either one of the capacitor discharging operation” makes discharging for others as well.

CAUTION:

1. **Be sure to discharge the capacitor on MAIN PCB.**
2. **Be careful of the high voltage circuit on MAIN PCB when servicing.**

[Discharging Procedure]

1. Refer to the disassemble procedure and remove the necessary parts/unit.
2. Put the insulation tube onto the lead part of Resistor (ERG5SJ102:1k Ω /5W).
(An equivalent type of resistor may be used.)
3. Put the resistor between both terminals of capacitor on MAIN PCB for approx. 5 seconds.
4. After discharging confirm that the capacitor voltage is lower than 10V using a voltmeter.

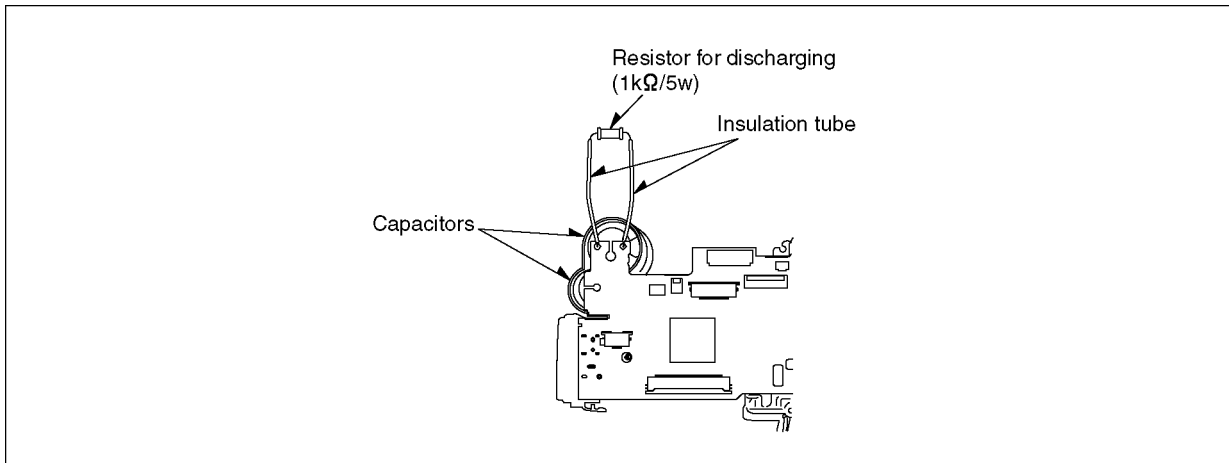


Fig. F1

2 Warning

2.1. Prevention of Electrostatic Discharge (ESD) to Electrostatic Sensitive (ES) Devices

Some semiconductor (solid state) devices can be damaged easily by static electricity. Such components commonly are called Electrostatically Sensitive (ES) Devices.

Examples of typical ES devices are CCD image sensor, IC (integrated circuits) and some field-effect transistors and semiconductor "chip" components.

The following techniques should be used to help reduce the incidence of component damage caused by electrostatic discharge (ESD).

1. Immediately before handling any semiconductor component or semiconductor-equipped assembly, drain off any ESD on your body by touching a known earth ground. Alternatively, obtain and wear a commercially available discharging ESD wrist strap, which should be removed for potential shock reasons prior to applying power to the unit under test.
2. After removing an electrical assembly equipped with ES devices, place the assembly on a conductive surface such as aluminum foil, to prevent electrostatic charge buildup or exposure of the assembly.
3. Use only a grounded-tip soldering iron to solder or unsolder ES devices.
4. Use only an antistatic solder removal device. Some solder removal devices not classified as **antistatic (ESD protected)** can generate electrical charge sufficient to damage ES devices.
5. Do not use freon-propelled chemicals. These can generate electrical charges sufficient to damage ES devices.
6. Do not remove a replacement ES device from its protective package until immediately before you are ready to install it. (Most replacement ES devices are packaged with leads electrically shorted together by conductive foam, aluminum foil or comparable conductive material).
7. Immediately before removing the protective material from the leads of a replacement ES device, touch the protective material to the chassis or circuit assembly into which the device will be installed.

CAUTION:

Be sure no power is applied to the chassis or circuit, and observe all other safety precautions.

8. Minimize bodily motions when handling unpackaged replacement ES devices. (Otherwise harmless motion such as the brushing together of your clothes fabric or the lifting of your foot from a carpeted floor can generate static electricity (ESD) sufficient to damage an ES device).

2.2. How to Recycle the Lithium Ion Battery (U.S. Only)

ENGLISH



A lithium ion/polymer battery that is recyclable powers the product you have purchased. Please call 1-800-8-BATTERY for information on how to recycle this battery.

FRANÇAIS



L'appareil que vous vous êtes procuré est alimenté par une batterie au lithium-ion/polymère recyclable. Pour des renseignements sur le recyclage de la batterie, veuillez composer le 1-800-8-BATTERY.

2.3. Caution for AC Cord (For EB/GC/SG)

2.3.1. Information for Your Safety

IMPORTANT

Your attention is drawn to the fact that recording of pre-recorded tapes or discs or other published or broadcast material may infringe copyright laws.

WARNING

To reduce the risk of fire or shock hazard, do not expose this equipment to rain or moisture.

CAUTION

To reduce the risk of fire or shock hazard and annoying interference, use the recommended accessories only.

FOR YOUR SAFETY

DO NOT REMOVE THE OUTER COVER

To prevent electric shock, do not remove the cover. No user serviceable parts inside. Refer servicing to qualified service personnel.

2.3.2. Caution for AC Mains Lead

For your safety, please read the following text carefully.

This appliance is supplied with a moulded three-pin mains plug for your safety and convenience.

A 5-ampere fuse is fitted in this plug.

Should the fuse need to be replaced please ensure that the replacement fuse has a rating of 5 amperes and it is approved by ASTA or BSI to BS1362

Check for the ASRA mark or the BSI mark on the body of the fuse.



If the plug contains a removable fuse cover you must ensure that it is refitted when the fuse is replaced.

If you lose the fuse cover, the plug must not be used until a replacement cover is obtained.

A replacement fuse cover can be purchased from your local Panasonic Dealer.

If the fitted moulded plug is unsuitable for the socket outlet in your home then the fuse should be removed and the plug cut off and disposed of safely.

There is a danger of severe electrical shock if the cut off plug is inserted into any 13-ampere socket.

If a new plug is to be fitted please observe the wiring code as shown below.

If in any doubt, please consult a qualified electrician.

2.3.2.1. Important

The wires in this mains lead are coloured in accordance with the following code:

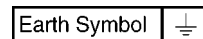
Blue	Neutral
Brown	Live

As the colours of the wires in the mains lead of this appliance may not correspond with the coloured markings identifying the terminals in your plug, proceed as follows:

The wire which is coloured BLUE must be connected to the terminal in the plug which is marked with the letter N or coloured BLACK.

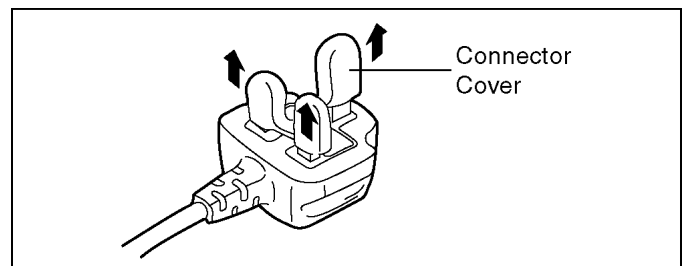
The wire which is coloured BROWN must be connected to the terminal in the plug which is marked with the letter L or coloured RED.

Under no circumstances should either of these wires be connected to the earth terminal of the three pin plug, marked with the letter E or the Earth Symbol.



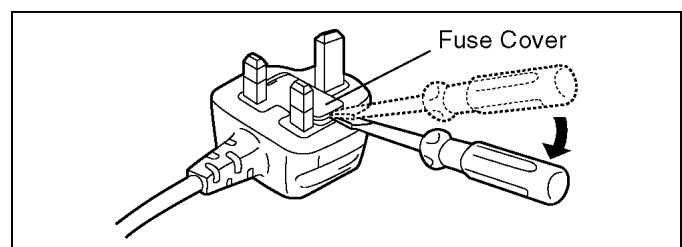
2.3.2.2. Before Use

remove the Connector Cover as follows.

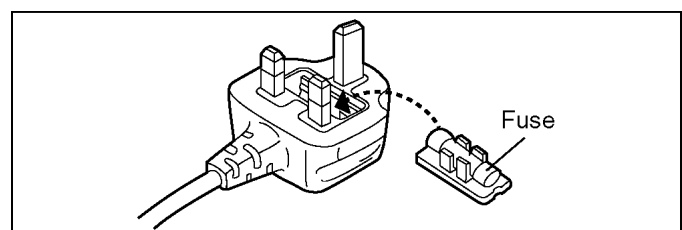


2.3.2.3. How to Replace the Fuse

1. Remove the Fuse Cover with a screwdriver.



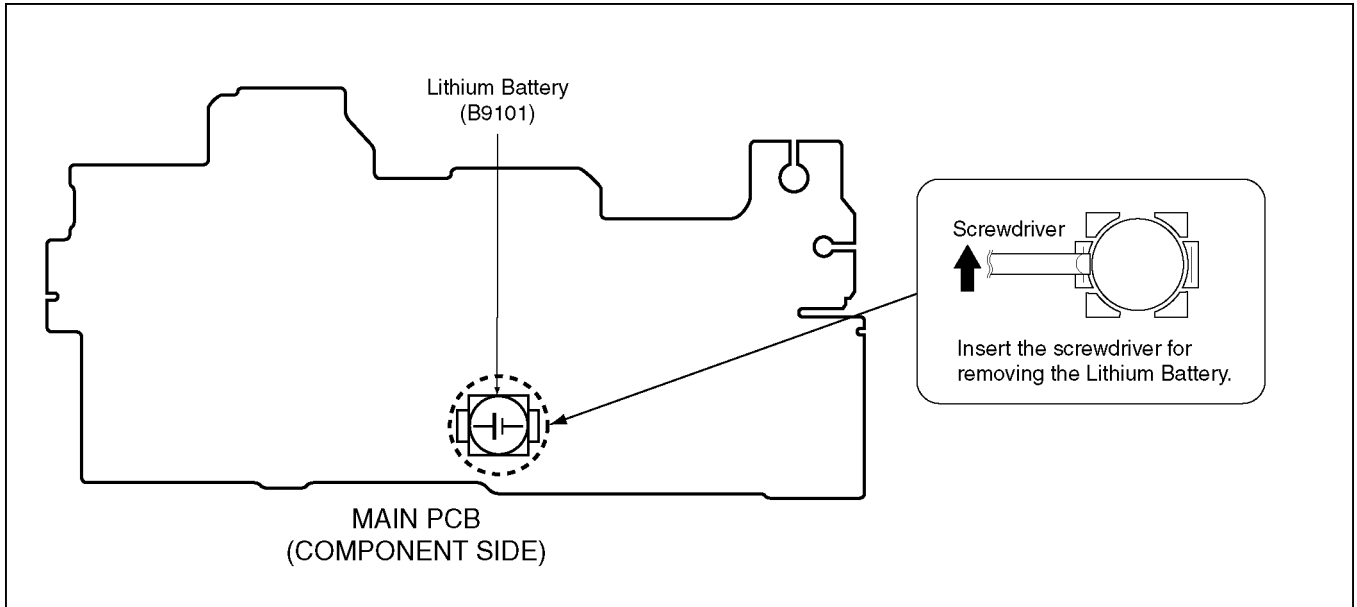
2. Replace the fuse and attach the Fuse cover.



2.4. How to Replace the Lithium Battery

2.4.1. Replacement Procedure

1. Remove the Main PCB. (Refer to Disassembly Procedures.)
2. Remove the Lithium battery (Ref. No. **B9101** at component side of Main PCB) and then replace it into new one.



Note:

The lithium battery is a critical component.

(Type No.: ML-614S/ZT **Manufactured by Matsushita Battery Industrial Co.,Ltd.**)

It must never be subjected to excessive heat or discharge.

It must therefore only be fitted in equipment designed specifically for its use.

Replacement batteries must be of the same type and manufacture.

They must be fitted in the same manner and location as the original battery, with the correct polarity contacts observed.

Do not attempt to re-charge the old battery or re-use it for any other purpose.

It should be disposed of in waste products destined for burial rather than incineration.

(For English)

CAUTION

Danger of explosion if battery is incorrectly replaced.

Replace only with the same or equivalent type recommended by the manufacturer.

Dispose of used batteries according to the manufacturer's instructions.

(For German)

ACHTUNG

Explosionsgefahr bei falschem Anbringen der Batterie. Ersetzen Sie nur mit einem äquivalentem vom Hersteller empfohlenem Typ.

Behandeln Sie gebrauchte Batterien nach den Anweisungen des Herstellers.

(For French)

MISE EN GARDE

Une batterie de remplacement inappropriée peut exploser. Ne remplacez qu'avec une batterie identique ou d'un type recommandé par le fabricant. L'élimination des batteries usées doit être faite conformément aux instructions du fabricant.

NOTE:

Above caution is applicable for a battery pack which is for DMC-FZ28 series, as well.

3 Service Navigation

3.1. Introduction

This service manual contains technical information, which will allow service personnel's to understand and service this model.

Please place orders using the parts list and not the drawing reference numbers.

If the circuit is changed or modified, the information will be followed by service manual to be controlled with original service manual.

3.2. General Description About Lead Free Solder (PbF)

The lead free solder has been used in the mounting process of all electrical components on the printed circuit boards used for this equipment in considering the globally environmental conservation.

The normal solder is the alloy of tin (Sn) and lead (Pb). On the other hand, the lead free solder is the alloy mainly consists of tin (Sn), silver (Ag) and Copper (Cu), and the melting point of the lead free solder is higher approx.30 °C (86 °F) more than that of the normal solder.

Definition of PCB Lead Free Solder being used

The letter of PbF is printed either foil side or components side on the PCB using the lead free solder. (See right figure)	PbF
--	------------

Service caution for repair work using Lead Free Solder (PbF)

- The lead free solder has to be used when repairing the equipment for which the lead free solder is used.
- (Definition: The letter of **PbF** is printed on the PCB using the lead free solder.)
- To put lead free solder, it should be well molten and mixed with the original lead free solder.
- Remove the remaining lead free solder on the PCB cleanly for soldering of the new IC.
- Since the melting point of the lead free solder is higher than that of the normal lead solder, it takes the longer time to melt the lead free solder.
- Use the soldering iron (more than 70W) equipped with the temperature control after setting the temperature at 350±30 degrees C (662±86 °F).

Recommended Lead Free Solder (Service Parts Route.)

- The following 3 types of lead free solder are available through the service parts route.
 - RFKZ03D01K------(0.3mm 100g Reel)
 - RFKZ06D01K------(0.6mm 100g Reel)
 - RFKZ10D01K------(1.0mm 100g Reel)

Note

* Ingredient: tin (Sn) 96.5%, silver (Ag) 3.0%, Copper (Cu) 0.5%, Cobalt (Co) / Germanium (Ge) 0.1 to 0.3%

3.3. Important Notice 1:(Other than U.S.A. and Canadian Market)

1. The service manual does not contain the following information, because of the impossibility of servicing at component level without concerned equipment/facilities.
 - a. Schematic diagram, Block Diagram and PCB layout of MAIN PCB.
 - b. Parts list for individual parts for MAIN PCB.When a part replacement is required for repairing MAIN PCB, replace as an assembled parts. (MAIN PCB)
2. The following category is/are recycle module part. please send it/them to Central Repair Center.
 - MAIN PCB (VEP56068A) : Excluding replacement of Lithium Battery.

3.4. How to Define the Model Suffix (NTSC or PAL model)

There are seven kinds of DMC-FZ28, regardless of the colours.









- a) DMC-FZ28 (Japan domestic model.)
- b) DMC-FZ28P/PC
- c) DMC-FZ28EB/EF/EG/E/GN
- d) DMC-FZ28EE
- e) DMC-FZ28GD
- f) DMC-FZ28GT
- g) DMC-FZ28PL/GC/SG/GK/GJ

(DMC-FZ28S is exclusively Japan domestic model.)

What is the difference is that the "INITIAL SETTINGS" data which is stored in Flash ROM mounted on Main PCB.

3.4.1. Defining methods

To define the model suffix to be serviced, refer to the nameplate which is putted on the bottom side of the Unit.

<p>a) DMC-FZ28 (Japan domestic model) , DMC-FZ28SG The nameplate for this model shows the following Safety registration mark.</p>	
	
<p>b) DMC-FZ28P/PC The nameplate for these models show the following Safety registration mark.</p>	
	
<p>c) DMC-FZ28EB/EF/EG/E/GN The nameplate for these models show the following Safety registration mark.</p>	
	
<p>d) DMC-FZ28EE The nameplate for this model show the following Safety registration mark.</p>	
	
<p>e) DMC-FZ28GD The nameplate for this model show the following Safety registration mark.</p>	
	
<p>f) DMC-FZ28GT The nameplate for this model show the following Safety registration mark.</p>	
	
<p>g) DMC-FZ28GK The nameplate for this model show the following Safety registration mark.</p>	
	
<p>h) DMC-FZ28PL/GC/GK/GJ The nameplate for these models do not show any above safety registration mark.</p>	

NOTE:

After replacing the MAIN PCB, be sure to achieve adjustment.

The adjustment instruction is available at "software download" on the "Support Information from NWBG/VDBG-PAVC" web-site in "TSN system", together with Maintenance software.

3.4.2. INITIAL SETTINGS:

When you replace the Main/Flash ROM, be sure to perform the initial settings after achieving the adjustment by ordering the following procedure in accordance with model suffix of the unit.

1. IMPORTANT NOTICE:

Before proceeding Initial settings, be sure to read the following CAUTIONS.

CAUTION 1 (INITIAL SETTINGS)

--- AFTER REPLACING THE MAIN P.C.B./FLASH ROM ---

* The model suffix can be chosen JUST ONE TIME.

(Model suffix : "E/EB/EE/EF/EG/GC/GD/GJ/GK/GN/GT/P/PC/PL/SG and NONE(JAPAN)")

* Once one of the model suffix have been chosen, the model suffix lists will not be displayed, thus, it can not be changed.

[NOTE: Only for "EG.E/EF/EB/EE" models]

* When one of the "EG.E, EF, EB, and EE" are chosen, "EG.E, EF, EB, and EE" are displayed from second times.

CAUTION 2 (Picture back up from "Built-in Memory")

This unit "Built-in Memory" for picture image data recording. (Approx. 50MB)

Be sure make picture data back up (i.e., Copying to SD memory card), before proceeding "INITIAL SETTING".

Once "INITIAL SETTING" has been carried out, all image data stored at "Built-in Memory" is erased.

2. PROCEDURES:

- Preparation. Proceed the picture back up from the unit (Refer to above "CAUTION 2")
- **Step 1. The temporary cancellation of initial setting:**
Set the REC/PLAY switch to "[Recording]".
Set the mode dial to "[P]".
While keep pressing [AF macro/Focus button] and "[UP] of Cursor button" simultaneously, turn the Power on.
- **Step 2. The cancellation of initial setting:**
Set the REC/PLAY switch to "[Playback]".
Press [AF macro/Focus switch] and "[UP] of Cursor button" simultaneously, turn the Power off.
- **Step 3. Turn the Power on:**
Set the REC/PLAY switch to "[Recording]", turn the Power on.

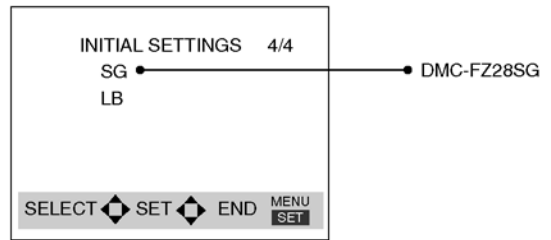
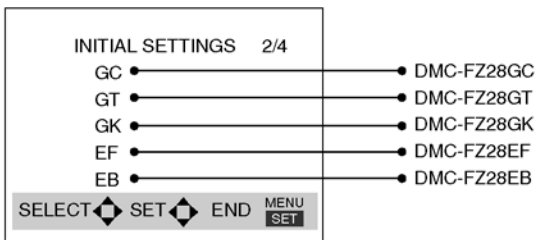
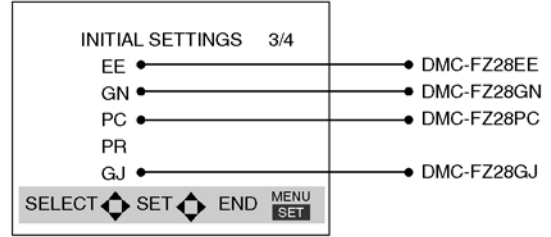
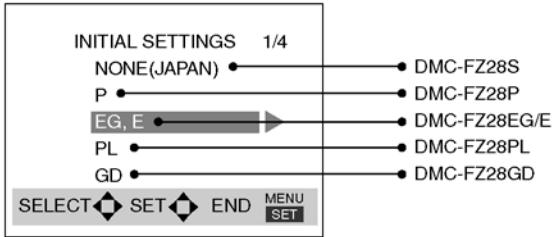
• **Step 4. Display the INITIAL SETTING:**

While keep pressing [MENU] and “[RIGHT] of Cursor button” simultaneously, turn the Power off.

When Main PCB/Flash ROM is replaced, all of the model suffix is displayed as follows.

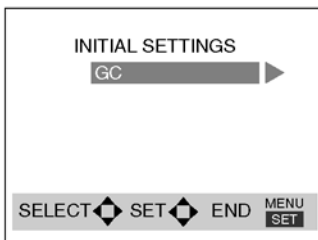
There are two kinds of “INITIAL SETTINGS” menu format.

[1. After replacing MAIN P.C.B./FLASH ROM]

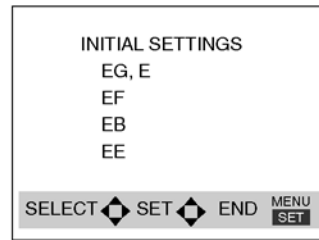


[2. Other than “After replacing MAIN P.C.B./FLASH ROM”]

<Other than "EG, E/EF/EB/EE" models>



<Only for "EG, E/EF/EB/EE" models>



• **Step 5. Set the INITIAL SETTING:** (Refer to “CAUTION 1”)

[Caution for before settings]

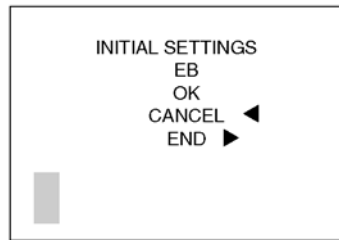
[Caution : After replacing MAIN P.C.B./FLASH ROM]

The model suffix can be chosen JUST ONE TIME.

Once one of the model suffix have been chosen, the model suffix lists will not be displayed, thus, it can not be changed.

Select the area carefully.

Select the area with pressing “[UP]/[DOWN] of Cursor button”, and then press the “[RIGHT] of Cursor button”.



The only set area is displayed, and then press the “[RIGHT] of Cursor button” after confirmation.

(The unit is powered off automatically.)

Confirm the display of “PLEASE SET THE CLOCK” in English when the unit is turned on again.

• **Step 6. CONFIRMATION:**

The display shows “PLEASE SET THE CLOCK” when turn the Power on again.

When the unit is connected to PC with USB cable, it is detected as removable media.

1) As for your reference Default setting condition is given in the following table.

• **Default setting (After “INITIAL SETTINGS”)**

	MODEL	VIDEO OUTPUT	LANGUAGE	DATE	REMARKS
a)	DMC-FZ28S	NTSC	Japanese	Year/Month/Date	
b)	DMC-FZ28P/PC/PL	NTSC	English	Month/Date/Year	
c)	DMC-FZ28EB/EG/E/GC/GN/GJ/SG	PAL	English	Date/Month/Year	
d)	DMC-FZ28EF	PAL	French	Date/Month/Year	
e)	DMC-FZ28EE	PAL	Russian	Date/Month/Year	
f)	DMC-FZ28GK	PAL	Chinese (simplified)	Year/Month/Date	
g)	DMC-FZ28GT	NTSC	Chinese (traditional)	Year/Month/Date	
h)	DMC-FZ28GD	NTSC	Korean	Year/Month/Date	

4 Specifications

Digital Camera: Information for your safety

Power Source:	DC 8.4 V
Power Consumption:	1.3 W (When recording with LCD Monitor) 1.2 W (When recording with Viewfinder) 0.6 W (When playing back with LCD Monitor) 0.5 W (When playing back with Viewfinder)

Camera effective pixels:	10,100,000 pixels
Image sensor:	1/2.33" CCD, total pixel number 10,700,000 pixels, Primary color filter
Lens:	Optical 18×zoom, f=4.8 mm to 86.4 mm (35 mm film camera equivalent: 27 mm to 486 mm)/F2.8 to F4.4
Digital zoom:	Max. 4×
Extended optical zoom:	Max. 32.1×
Focus:	Normal/AF Macro/Manual focus Face detection/Multi-area-focusing/ 1-area-focusing (High speed)/1-area-focusing/Spot-focusing/ AF Tracking
Focus range:	AF: 30 cm (0.99 feet) (Wide)/2 m (6.57 feet) (Tele) to ∞ AF Macro/MF/Intelligent auto: 1 cm (0.04 feet) (Wide)/2 m (6.57 feet) (Tele) to ∞ However, 1 m (3.28 feet) to ∞ for 11× to 18× zoom Scene mode: There may be differences in the above settings.
Shutter system:	Electronic shutter+Mechanical shutter
Motion picture recording:	1280×720 pixels (30 frames/second, only when using a Card) 848×480 pixels (30 frames/second, only when using a Card) 640×480 pixels (30 frames/second, only when using a Card) 320×240 pixels (30 frames/second, 10 frames/second) With audio
Burst recording	
Burst speed:	2.5 pictures/second (Normal), Approx. 2 pictures/second (Unlimited)
Number of recordable pictures:	Max. 5 pictures (Standard), max. 3 pictures (Fine), Depends on the remaining capacity of the built-in memory or the card (Unlimited). (Performance in burst recording is only with SD Memory Card/SDHC Memory Card. MultiMediaCard performance will be less.)

Hi-speed burst	
Burst speed:	11 pictures/second ([SPEED PRIORITY]: 3M (4:3)) 12 pictures/second ([SPEED PRIORITY]: 2.5M (3:2)) 13 pictures/second ([SPEED PRIORITY]: 2M (16:9)) 7 pictures/second ([IMAGE PRIORITY]: 3M (4:3), 2.5M (3:2) or 2M (16:9))
Number of recordable pictures:	20 to 60 ([SPEED PRIORITY]) 20 to 100 ([IMAGE PRIORITY]) (differs depending on the type of Card and the recording conditions)
ISO sensitivity:	AUTO/100/200/400/800/1600 [HIGH SENS.] mode: 1600 to 6400
Shutter speed:	60 seconds to 1/2000th of a second [STARRY SKY] mode: 15 seconds, 30 seconds, 60 seconds
White balance:	Auto white balance/Daylight/Cloudy/Shade/Flash/Incandescent lights/White set1/White set2/White balance K set
Exposure (AE):	Program AE (P)/Aperture-priority AE (A)/Shutter-priority AE (S)/Manual exposure (M) Exposure compensation (1/3 EV Step, -2 EV to +2 EV)
Metering mode:	Multiple/Center weighted/Spot
LCD monitor:	2.7" TFT LCD (Approx. 230,000 dots) (field of view ratio about 100%)
Viewfinder:	Color LCD Viewfinder (Approx. 201,000 pixels) (field of view ratio about 100%) (with diopter adjustment -4 to +4 diopter)
Flash:	Built-in pop up flash Flash range: [ISO AUTO] Approx. 30 cm (0.99 feet) to 8.5 m (27.9 feet) (Wide) AUTO, AUTO/Red-eye reduction, Forced flash ON (Forced ON/Red-eye reduction), Slow sync./Red-eye reduction, Forced flash OFF
Microphone:	Monaural
Speaker:	Monaural
Recording media:	Built-in Memory (Approx. 50 MB)/SD Memory Card/SDHC Memory Card/MultiMediaCard (Still pictures only)
Picture size	
Still picture:	When the aspect ratio setting is [4:3] 3648×2736 pixels, 3072×2304 pixels, 2560×1920 pixels, 2048×1536 pixels, 1600×1200 pixels, 640×480 pixels When the aspect ratio setting is [3:2] 3648×2432 pixels, 3072×2048 pixels, 2560×1712 pixels, 2048×1360 pixels When the aspect ratio setting is [16:9] 3648×2056 pixels, 3072×1728 pixels, 2560×1440 pixels, 1920×1080 pixels
Motion pictures:	1280×720 pixels (Only when using a Card) 848×480 pixels (Only when using a Card) 640×480 pixels (Only when using a Card) 320×240 pixels

Quality: Fine/Standard/RAW/RAW+JPEG

Recording file format

Still Picture: JPEG (based on "Design rule for Camera File system", based on "Exif 2.21" standard)/RAW, DPOF corresponding

Pictures with audio: JPEG (based on "Design rule for Camera File system", based on "Exif 2.21" standard)+ "QuickTime" (pictures with audio)

Motion pictures: "QuickTime Motion JPEG" (motion pictures with audio)

Interface

Digital: "USB 2.0" (High Speed)

Analog video/audio: NTSC (DMC-FZ28P) U.S. version
NTSC/PAL Composite (Switched by menu),
(DMC-FZ28PC) Canada version
Component
Audio line output (monaural)

Terminal

[COMPONENT OUT]: Dedicated jack (10 pin)

[DIGITAL/AV OUT]: Dedicated jack (8 pin)

[DC IN]: Type 3 jack

Dimensions: Approx. 117.6 mm (W)×75.3 mm (H)×88.9 mm (D)
[4 3/5" (W)×2 9/10"(H)×3 1/2" (D)] (excluding the projecting parts)

Mass (weight): Approx. 370 g/13.1 oz (excluding card and battery)
Approx. 417 g/14.7 oz (with card and battery)

Operating temperature: 0 °C to 40 °C (32 °F to 104 °F)

Operating humidity: 10% to 80%

Battery Charger (Panasonic DE-A43B):

Information for your safety

Input:	110 V to 240 V~50/60 Hz, 0.15 A
Output:	CHARGE 8.4 V---0.43 A

Equipment mobility: Movable

Battery Pack (lithium-ion) (Panasonic CGR-S006A):

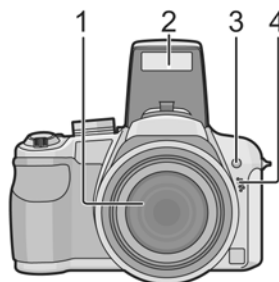
Information for your safety

Voltage:	7.2 V
-----------------	-------

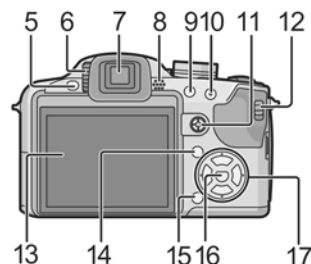
5 Location of Controls and Components

Names of the Components

- 1 Lens
- 2 Flash
- 3 Self-timer indicator
- AF assist lamp
- 4 Microphone

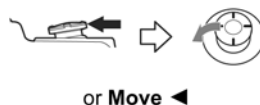


- 5 Flash open button
- 6 Diopter adjustment dial
- 7 Viewfinder
- 8 Speaker
- 9 [EVF/LCD] button
- 10 [AF/AE LOCK] button
- 11 Joystick



The joystick is operated in two different ways: it can be moved in the up, down, left and right directions to perform an operation, or it can be pressed to select. In these operating instructions, it is pictured as shown in the figure below or described with ▲/▼/◀/▶.

Example: When the joystick is moved toward ◀ (left)
Place your finger on the right side of the joystick, and move the joystick toward the left.



Push the joystick straight in.

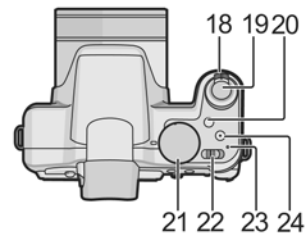


- 12 [REC]/[PLAYBACK] selector switch
 - 13 LCD monitor
 - 14 [DISPLAY] button
 - 15 Delete button/
Single or burst mode button
 - 16 [MENU/SET] button
 - 17 Cursor buttons
 - ◀/Self-timer button
 - ▼/Function button
- Assign [REC] Mode Menu to ▼ button. It is convenient to register [REC] Mode Menu that is used often.
[REVIEW]/[SENSITIVITY]/[WHITE BALANCE]/[METERING MODE]/[AF MODE]/[I.EXPOSURE]
▶/Flash setting button
▲/Exposure compensation/
Auto bracket/Color bracket/Flash output adjustment/

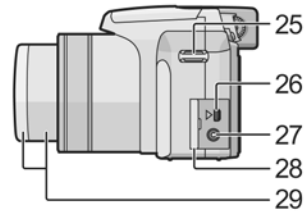
In these operating instructions, the cursor buttons are described as shown in the figure below or described with ▲/▼/◀/▶.
e.g.: When you press the ▼ (down) button



- 18 Zoom lever
- 19 Shutter button
- 20 [AF/FOCUS] button
- 21 Mode dial
- 22 Camera ON/OFF switch
- 23 Power lamp
- 24 [AF/MF] button

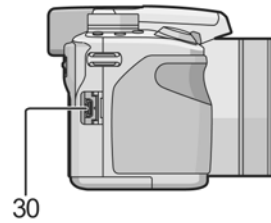


- 25 Strap eyelet
 - Be sure to attach the strap when using the camera to ensure that you will not drop it.
- 26 [DIGITAL/AV OUT] socket
- 27 [DC IN] socket
 - Always use a genuine Panasonic AC adaptor (DMW-AC7PP; optional).

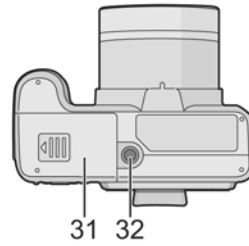


- This camera cannot charge the battery even when the AC adaptor (DMW-AC7PP; optional) is connected to it.
- 28 Terminal door
- 29 Lens barrel

- 30 [COMPONENT OUT] socket

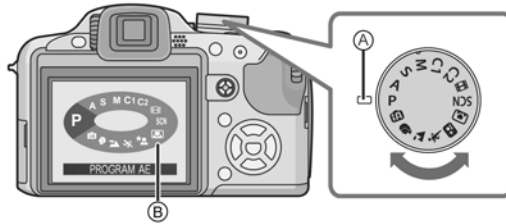


- 31 Card/Battery door
- 32 Tripod receptacle
 - When you use a tripod, make sure the tripod is stable when the camera is attached to it.



Mode Dial

- Switching the mode by rotating the mode dial.



Align a desired mode with part ①.

- Rotate the mode dial slowly and surely to adjust to each mode. (The mode dial rotates 360°)
- The screen ② is displayed on the LCD monitor/Viewfinder when the mode dial is turned.

■ Basic

Intelligent auto mode

The subjects are recorded using settings automatically selected by the camera.

Program AE mode

The subjects are recorded using your own settings.

■ Advanced

Aperture-priority AE mode

The shutter speed is automatically determined by the aperture value you set.

Shutter-priority AE mode

The aperture value is automatically determined by the shutter speed you set.

Manual exposure mode

The exposure is adjusted by the aperture value and the shutter speed which are manually adjusted.

Custom mode

Use this mode to take pictures with previously registered settings.

Motion picture mode

This mode allows you to record motion pictures.

Scene mode

This allows you to take pictures that match the scene being recorded.

■ Advanced scene mode

Portrait mode

Use this mode to take pictures of people.

Scenery mode

Use this mode to take pictures of scenery.

Sports mode

Use this mode to take pictures of sporting events, etc.

Night portrait mode

Use this mode to take pictures of night scenes and people with night time scenery.

Close-up mode

Use this mode to take picture of close-by subject.

6 Service Mode

6.1. Error Code Memory Function

1. General description

This unit is equipped with history of error code memory function, and can be memorized 16 error codes in sequence from the latest. When the error is occurred more than 16, the oldest error is overwritten in sequence.

The error code is not memorized when the power supply is shut down forcibly (when the unit is powered on by the battery, the battery is pulled out) because the error code is memorized to FLASH ROM when the unit is powered off.

2. How to display

The error code can be displayed by the following procedure:

Before perform the error code memory function, connect the AC adaptor or insert the battery.

(Since this unit has built-in memory, this error code memory function can be performed without inserting SD memory card.)

- **1. The temporary cancellation of initial setting:**

Set the REC/PLAY switch to “[Recording]”.

Set the mode dial to “[P]”.

While keep pressing [AF macro/Focus switch] and “[UP] of Cursor button” simultaneously, turn the Power on.

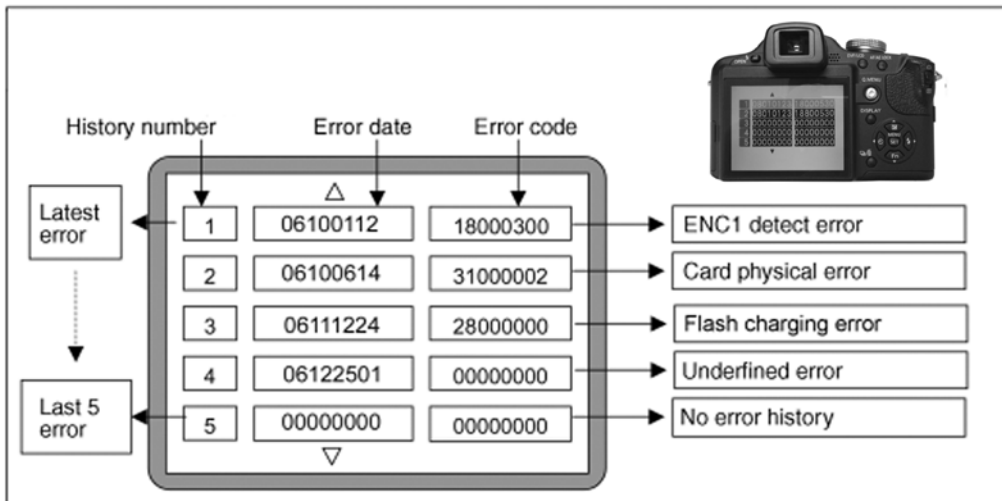
- **2. The display of error code:**

Press [AF macro/Focus switch], [MENU] and “[LEFT] of Cursor button” simultaneously with the step 1 condition.

The display is changed as shown below when the above buttons is pressed simultaneously.

Normal display → Error code display → Operation history display → Normal display →

Example of Error Code Display



Example of Error Code Display

- **3. The change of display:**

The error code can be memorized 16 error codes in sequence, however it is displayed 5 errors on the LCD.

Display can be changed by the following procedure:

“[UP] or [DOWN] of Cursor button” : It can be scroll up or down one.

“[LEFT] or [RIGHT] of Cursor button” : It can be display last 5 error or another 5 error.

- **4. How to read the error date:**

The error date code is displayed from the left in order at the year, month, day, time.

Error date information is acquired from “Clock setting” information when the error occurs.

When the clock is not setting, it is displayed as “00000000”.

• 5. How to read the error code:

One error code is displayed for 8 bit, the contents of error codes is indicated the table as shown below.

History number	Error date	Error code
1	06100112	18000300
2	06100614	31000002
3	06111224	28000000
4	06122501	00000000
5	00000000	00000000

Group	Main item	Sub item	Error code		Error Description (Upper frame)	
			Upper 4 bits	Low 4 bits	Remedy/Check point (Lower frame)	
LENS	Lens drive	OIS	18*0	1000	PSD (X) error. Hall element (X axis) position detect error in OIS unit. OIS Unit, IC7102.	
				2000	PSD (Y) error. Hall element (Y axis) position detect error in OIS unit. OIS Unit, IC7101.	
				3000	GYRO (X) error. Gyro (IC7102: X axis) detect error on Main P.C.B.. IC7102 (Gyro element) or IC6001 (VENUS 4)	
				4000	GYRO (Y) error. Gyro (IC7101: Y axis) detect error on Main P.C.B.. IC7101 (Gyro element) or IC6001 (VENUS 4)	
				5000	MREF error (Reference voltage error). IC9101 (LENS drive & SYSCON IC) or IC6001 (VENUS 4)	
				6000	Drive voltage (X) error. VENUS 4 AD value error, LENS Unit, LENS flex breaks etc.	
				7000	Drive voltage (Y) error. VENUS 4 AD value error, LENS Unit, LENS flex breaks etc.	
				Focus	0?01	HP High detect error (Focus encoder always detects High.). Mechanical lock, FP9005-(11) signal line or IC6001 (VENUS 4)
					0?02	HP Low detect error (Focus encoder always detects Low.). Mechanical lock, FP9005-(11) signal line or IC6001 (VENUS 4)
				Zoom	0?10	Collapsible barrel Low detect error (Collapsible barrel encoder always detects Low.) Mechanical lock, FP9005-(39) signal line or IC6001 (VENUS 4)
						0?20
					0?30	Zoom motor sensor error. Mechanical lock, FP9005-(2), (4) signal line or IC6001 (VENUS 4)
					0?40	Zoom motor sensor error. (During monitor mode.) Mechanical lock, FP9005-(2), (4) signal line or IC6001 (VENUS 4)
					0?50	Zoom motor sensor error. (During monitor mode with slow speed.) Mechanical lock, FP9005-(2), (4) signal line or IC6001 (VENUS 4)
		0003	MR A aspect output error FP9005-(23/25) signal line or IC6001 (VENUS 4)			
		Lens	10*3	0000	MR B aspect output error FP9005-(22/24) signal line or IC6001 (VENUS 4)	
				0000	Lens initializing error 1 Remove lens cap. Zoom Motor. Mechanical phase	
					10*8	Lens initializing error 2 (Although initializing operation is completed.) Remove lens cap. Zoom Motor. Mechanical phase
					18*1	Power ON time out error. Lens drive system
		18*2	Power OFF time out error. Lens drive system			
		Adj.History	OIS	19*0	2000	OIS adj. Yaw direction amplitude error (small)
					3000	OIS adj. Pitch direction amplitude error (small)
					4000	OIS adj. Yaw direction amplitude error (large)
					5000	OIS adj. Pitch direction amplitude error (large)
					6000	OIS adj. MREF error
					7000	OIS adj. time out error
					8000	OIS adj. Yaw direction off set error
					9000	OIS adj. Pitch direction off set error
					A000	OIS adj. Yaw direction gain error
					B000	OIS adj. Pitch direction gain error
					C000	OIS adj. Yaw direction position sensor error
					D000	OIS adj. Pitch direction position sensor error
E000	OIS adj. other error					
HARD	VENUS A/D				Flash	28*0
	FLASH ROM	FLASH ROM	2B*0	0001	EEPROM read error IC6002 (FLASH ROM & SDRAM)	
				0002	EEPROM write error IC6002 (FLASH ROM & SDRAM)	
	SDRAM Area	SDRAM Area		0008, 0009	SDRAM error IC6002 (FLASH ROM & SDRAM)	
	SYSTEM	RTC	2C*0	0001	SYSTEM IC initialize failure error	
					Communication between IC6001 (VENUS 4) and IC9101 (SYSTEM)	

Group	Main item	Sub item	Error code		Error Description (Upper frame)	
			Upper 4 bits	Low 4 bits	Remedy/Check point (Lower frame)	
SOFT	CPU	Reset	30*0	0001	NMI reset	
				I	Non Mask-able Interrupt	
	Card	Card	31*0	0007	(30000001-30000007 are caused by factors)	
					0001	SD memory card logic error
				0002	SD memory card data line or IC6001 (VENUS 4)	
					SD memory card physical error	
				0004	SD memory card data line or IC6001 (VENUS 4)	
					Write error	
				0005	SD card data line or IC6001 (VENUS 4)	
					Format error	
				39*0	0005	SD card data line or IC6001 (VENUS 4)
						Format error
	CPU, VENUS hard	Stop	38*0	0001	Camera task finish process time out.	
					Communication between Lens system and IC6001 (VENUS 4)	
				0002	Camera task invalid code error.	
					IC6001 (VENUS 4)	
				0100	File time out error in recording motion image	
					IC6001 (VENUS 4)	
				0200	File data send error in recording motion image	
					IC6001 (VENUS 4)	
0300				Single or burst recording brake time out.		
				Memory area	3A*0	0008
Operation	Power on	3B*0	0000	Turn OFF and ON the unit.		
Zoom	Zoom	3C*0	0000	FLASHROM processing early period of camera during movement.		
				Zoom lens processing is incomplete.		
			35*0	0000	Zoom lens, IC7001	
					When "BKI" and/or "WKI" adjustment is performed, this code may be registered by chance. No remedy is required.	
			35*1	0000	Software sequence error.	
					Connector is unlocked. /Flex cable is damaged.	
35*2	0000	Software sequence error.				
		Connector is unlocked. /Flex cable is damaged.				

1) About "*" indication in the above table:

The third digit from the left is different as follows.

In case of 0 (example: 18 0 01000)

When the third digit from the left shows "0", this error occurred under the condition of INITIAL SETTINGS has been completed.

It means that this error is occurred basically at user side.

In case of 8 (example: 18 8 01000)

When the third digit from the left shows "8", this error occurred under the condition of INITIAL SETTINGS has been released. (Example; Factory assembling-line before unit shipment, Service mode etc.)

It means that this error is occurred at service side.

2) About "?" indication in the above table: ("18*0 0?01" to "18*0 0?50")

The third digit from the right shows one of the hexadecimal ("0" to "F") character.

• 6. How to returned to Normal Display:

Turn the power off and on, to exit from Error code display mode.

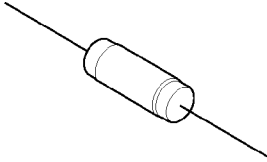
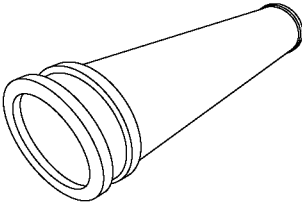
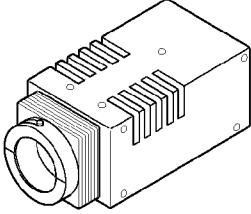
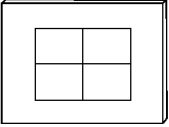
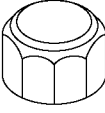


NOTE:

The error code can not be initialized.

7 Service Fixture & Tools

7.1. Service Fixture and Tools

The following Service Fixture and tools are used for checking and servicing this unit.

Resistor for Discharging ERG5SJ102	Infinity Lens (Built-in Focus Chart) RFKZ0422	LIGHT BOX VFK1164TDVLB
 <p>An equivalent type of Resistor may be used.</p>		 <p>※ with DC Cable</p>
TR Chart RFKZ0443	Dome type magnifying glass VFK1835	Grease (for focus motor) RFKZ0472
		
Lens Cleaning Kit (BK) VFK1900BK		
 <p>* Only supplied as 10 set/box.</p>		

7.2. Clean Box

7.2.1. Servicing the Lens unit.

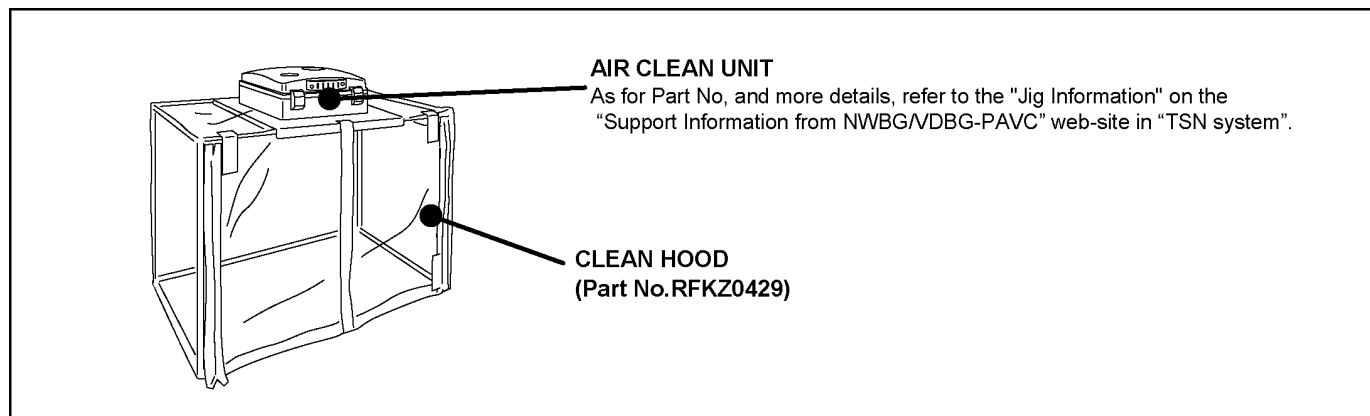
To keep dust proof environment when repairing lens unit, CLEAN BOX is recommended (less than class 10,000 Federal Standard 209D).

7.2.2. Introduction of Clean box.

One of our recommended clean box is as shown below.

It consists of "Air clean unit" and "Clean hood".

As for the "Air clean unit", refer to the "Jig Information" on the "Support Information from NWBG/VDBG-PAVC" web-site in "TSN system".



7.3. When Replacing the Main PCB

After replacing the MAIN PCB, be sure to achieve adjustment.

The adjustment instruction is available at "software download" on the "Support Information from NWBG/VDBG-PAVC" web-site in "TSN system", together with Maintenance software.

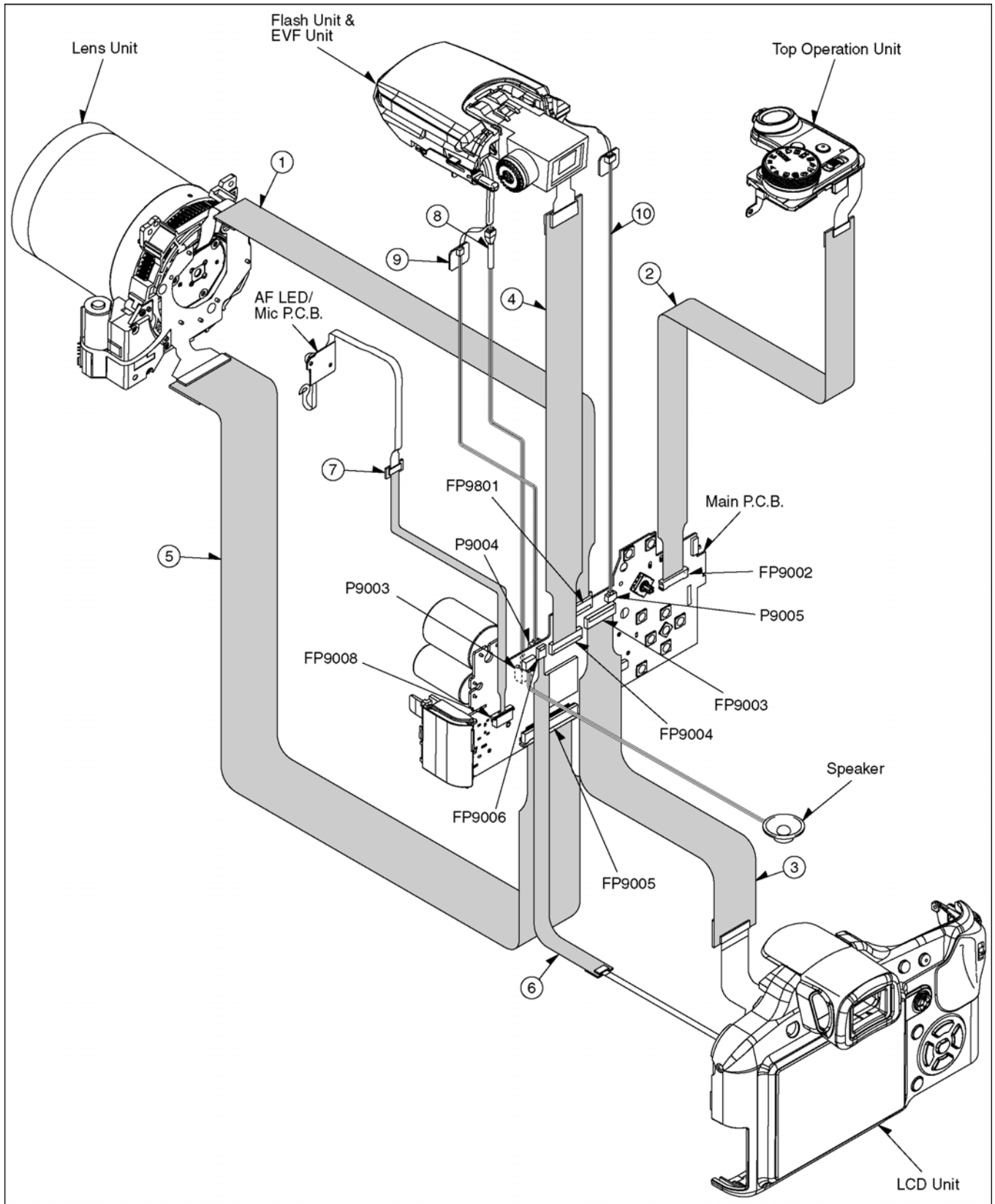
7.4. Service Position

This Service Position is used for checking and replacing parts. Use the following Extension cables for servicing.

Table S1 Extension Cable List

No.	Parts No.	Connection	Form
1	RFKZ0416	FP9801 (MAIN) - CCD UNIT	41 PIN 0.3 FFC
2	VFK1364	FP9002 (MAIN) - TOP OPERATION UNIT	14 PIN 0.5 FFC
3	RFKZ0477	FP9003 (MAIN) - LCD UNIT	45 PIN 0.3 FFC
4	VFK1282	FP9004 (MAIN) - EVF UNIT	22 PIN 0.5 FFC
5	VFK1953	FP9005 (MAIN) - LENS FPC UNIT	40 PIN 0.5 FFC
6	VFK1974	FP9006 (MAIN) - LCD UNIT	4 PIN 0.5 FFC
7	VFK1480	FP9008 (MAIN) - AF LED/MIC UNIT	6 PIN 0.5 FFC
8	RFKZ0359	P9003 (MAIN) - FLASH UNIT	2 PIN CABLE
9	VFK1576DC202	P9004 (MAIN) - FLASH UNIT	2 PIN CABLE
10	VFK1576DC202	P9005 (MAIN) - FLASH UNIT	2 PIN CABLE

7.4.1. Extension Cable Connections

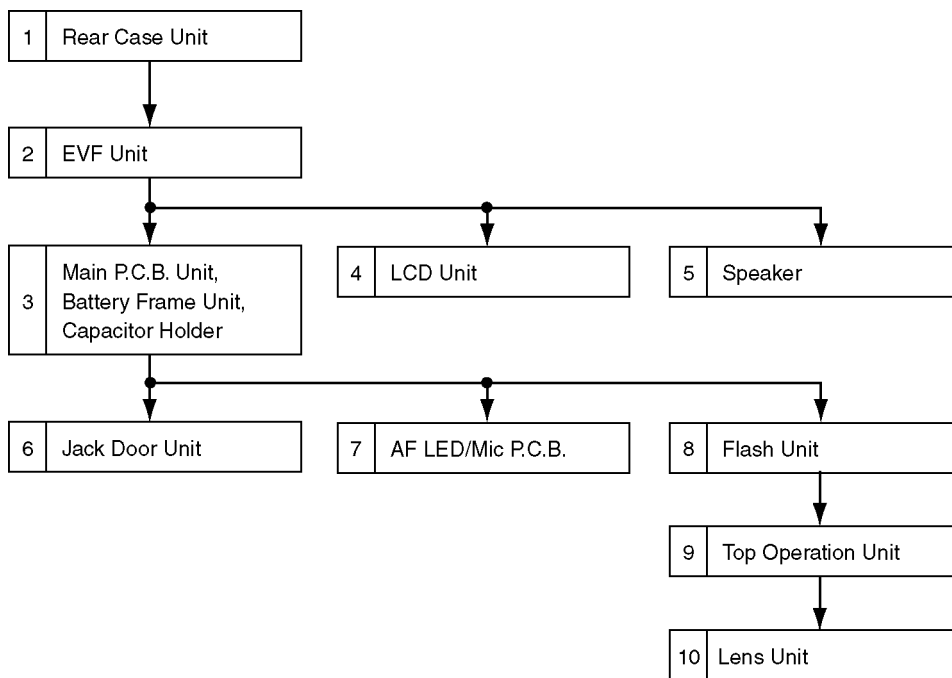


CAUTION-1. (When servicing MAIN PCB)

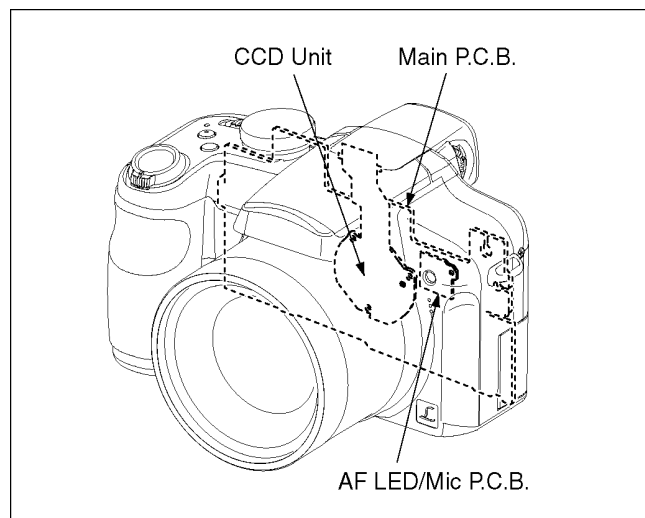
1. Be sure to discharge the capacitor on MAIN PCB.
Refer to "HOW TO DISCHARGE THE CAPACITOR ON MAIN PCB".
The capacitor voltage is not lowered soon even if the AC Cord is unplugged or the battery is removed.
2. Be careful of the high voltage circuit on MAIN PCB.
3. DO NOT allow other parts to touch the high voltage circuit on MAIN PCB.

8 Disassembly and Assembly Instructions

8.1. Disassembly Flow Chart



8.2. PCB Location



8.3. Disassembly Procedure

No.	Item	Fig.	Removal
1	Rear Case Unit	Fig. D1	Card
			Battery
			3 Screws (A)
			2 Screws (B)
			1 Screws (C)
		Fig. D2	P9001 (Connector)
			FP9003 (Flex)
			FP9006 (Flex)
			Rear Case Unit
2	EVF Unit	Fig. D3	FP9004 (Flex) EVF Unit
3	Main P.C.B. Unit, Battery Frame Unit, Capacitor holder	Fig. D4	2 Screws (D)
			1 Screw (E)
			FP9002 (Flex)
			FP9005 (Flex)
			FP9801 (Flex)
			P9003 (Connector)
			P9004 (Connector)
			P9005 (Connector)
			Main P.C.B. Unit
			Fig. D5
		6 Locking tabs	
		FP9008 (Flex)	
		Battery Frame Unit	
		Capacitor Holder	
		4	LCD Unit
5	Speaker	Fig. D7	2 Screws (H) Plate Speaker
6	Jack Door Unit	Fig. D8	1 Screw (I) Jack Door Unit
7	AF LED/Mic P.C.B.	Fig. D9	2 Locking tabs AF LED P.C.B. Holder AF LED/Mic P.C.B.
8	Flash Unit	Fig. D10	Flash Unit
9	Top Operation Unit	Fig. D11	Top Operation Unit
10	Lens Unit	Fig. D12	1 Screw (J)
			Lens Unit

8.3.1. Removal of the Rear Case Unit

NOTE:
When servicing and reassembling, remove the card and battery from the unit.

- Card
- Battery
- Screw (A) × 3
- Screw (B) × 2
- Screw (C) × 1

Screw (A) **Screw (B)** **Screw (C)**

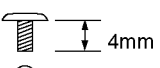
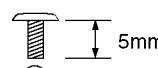
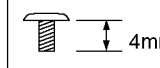
 4mm (S): SILVER (K): BLACK	 5mm (S): SILVER (K): BLACK	 4mm BLACK
--	---	---

Fig. D1

8.3.2. Removal of the EVF Unit

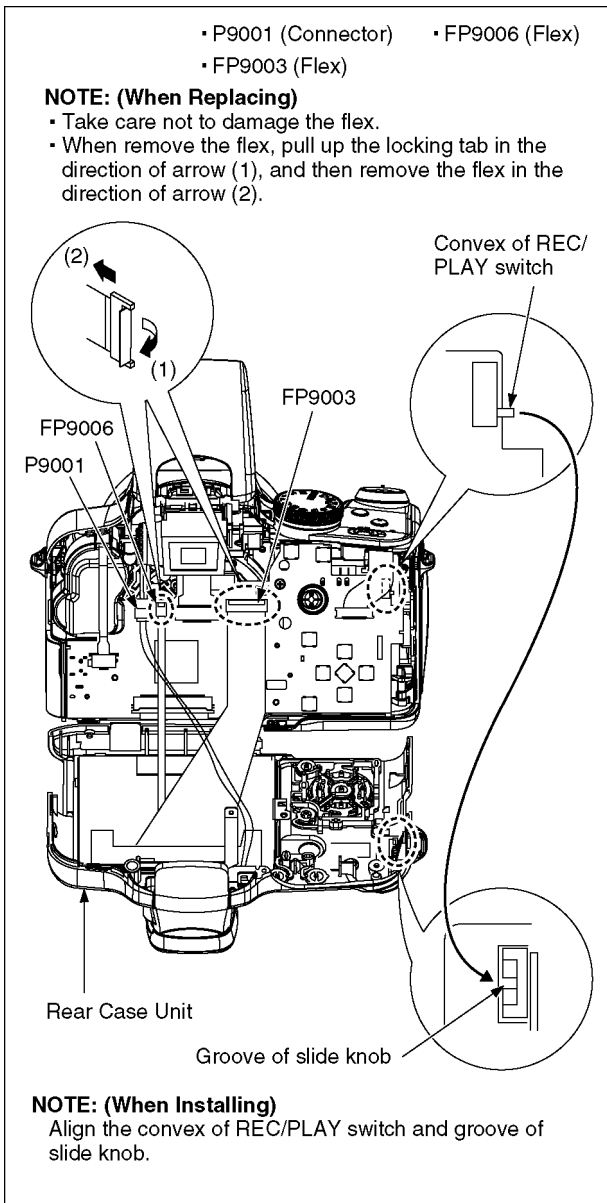


Fig. D2

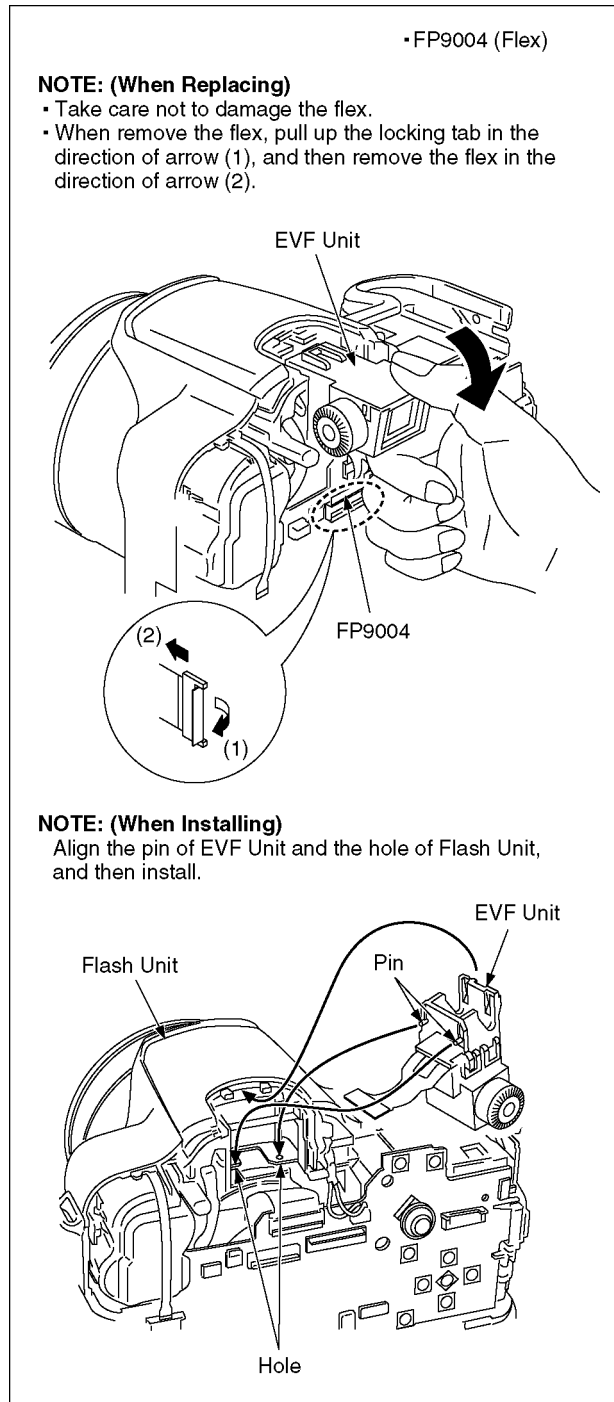


Fig. D3

8.3.3. Removal of the Main P.C.B. Unit, Battery Frame Unit and Capacitor Holder

- This unit equipped with two pieces of capacitors as flash charging capacitors.
- “Either one of the capacitor discharging operation” makes discharging for others as well.

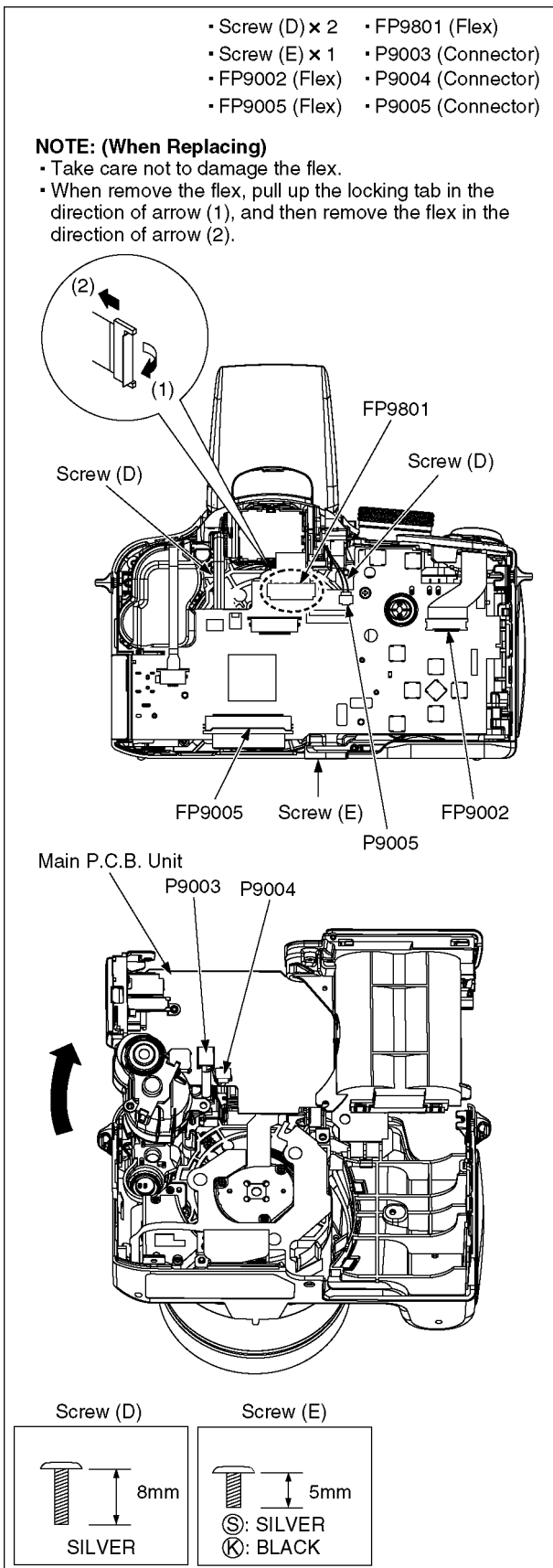


Fig. D4

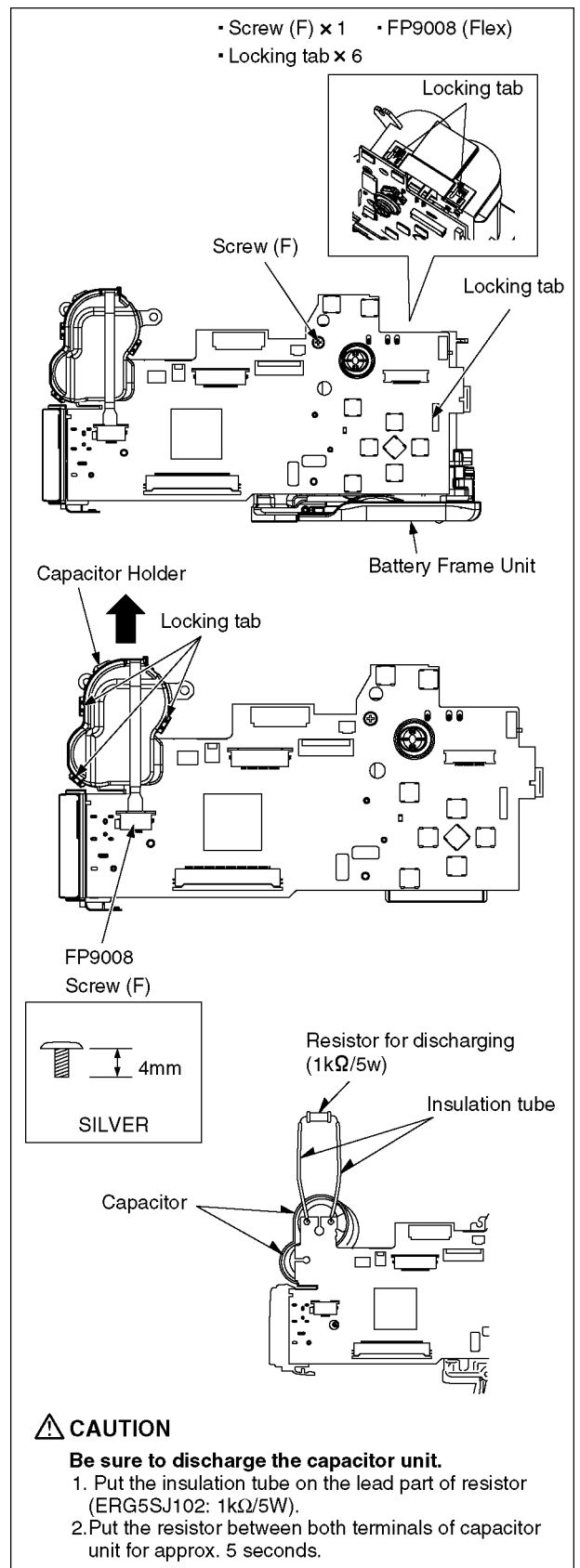


Fig. D5

8.3.4. Removal of the LCD Unit

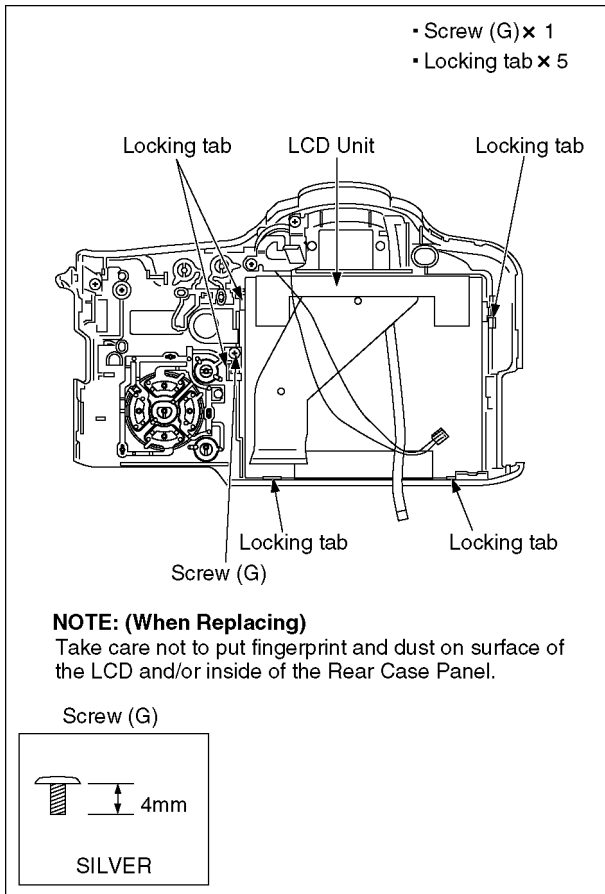


Fig. D6

8.3.5. Removal of the Speaker

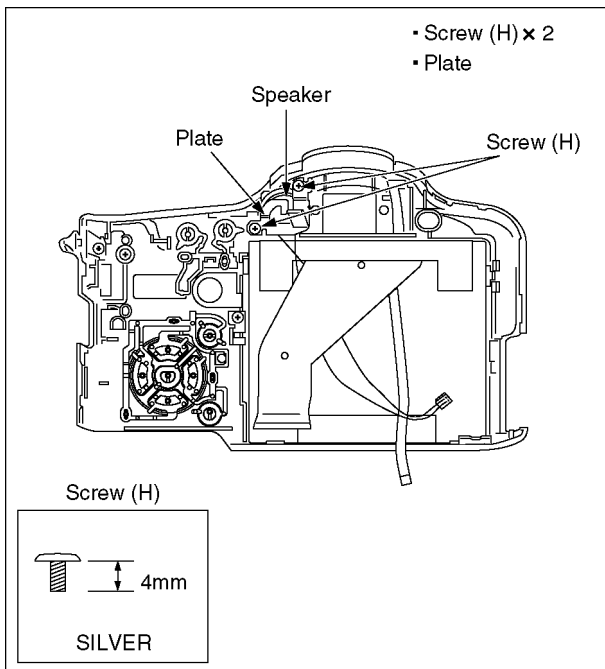


Fig. D7

8.3.6. Removal of the Jack Door Unit

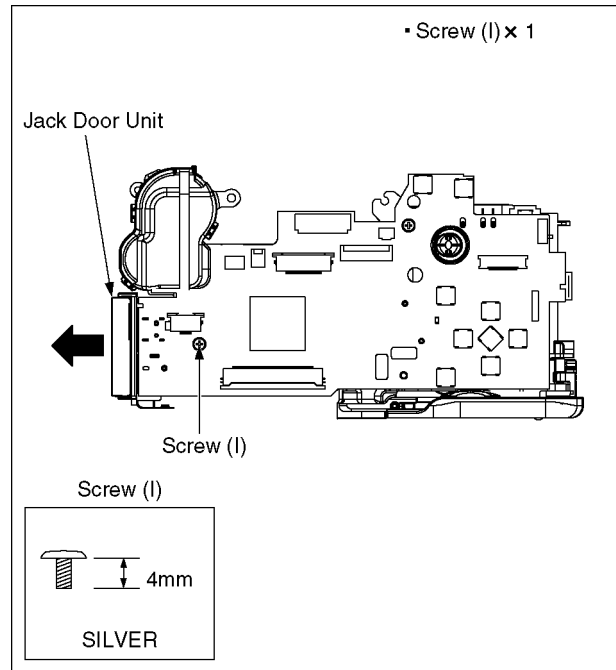


Fig. D8

8.3.7. Removal of the AF LED/Mic P.C.B.

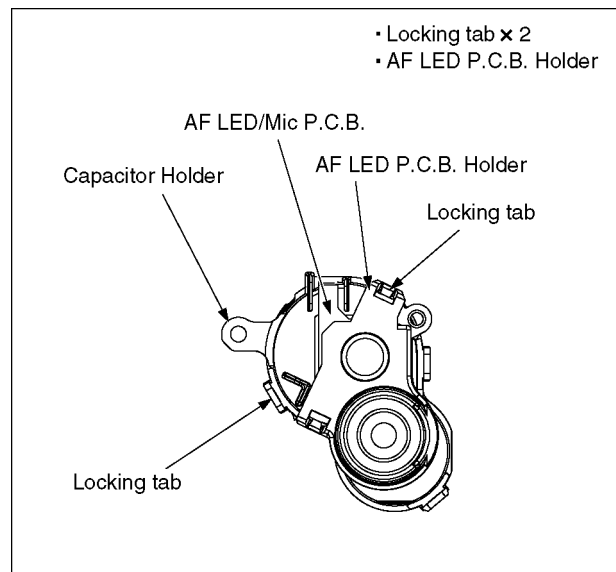


Fig. D9

8.3.8. Removal of the Flash Unit

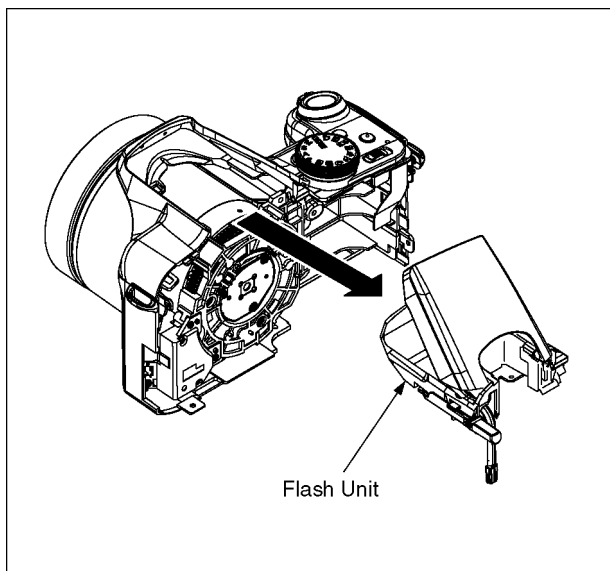


Fig. D10

8.3.9. Removal of the Top Operation Unit

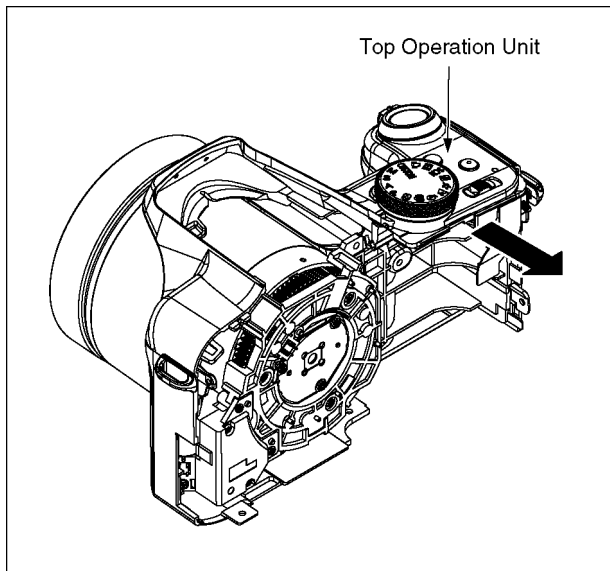


Fig. D11

8.3.10. Removal of the Lens Unit

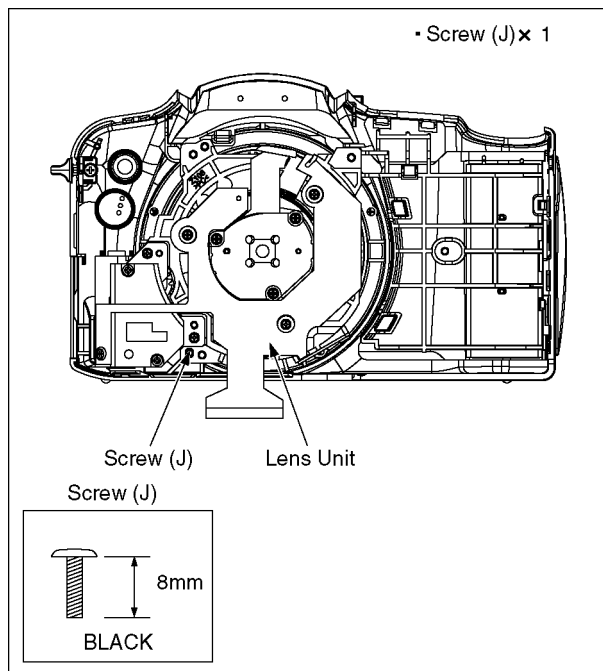


Fig. D12

NOTE: (When Assembling)

Be sure to confirm the following points when assembling.

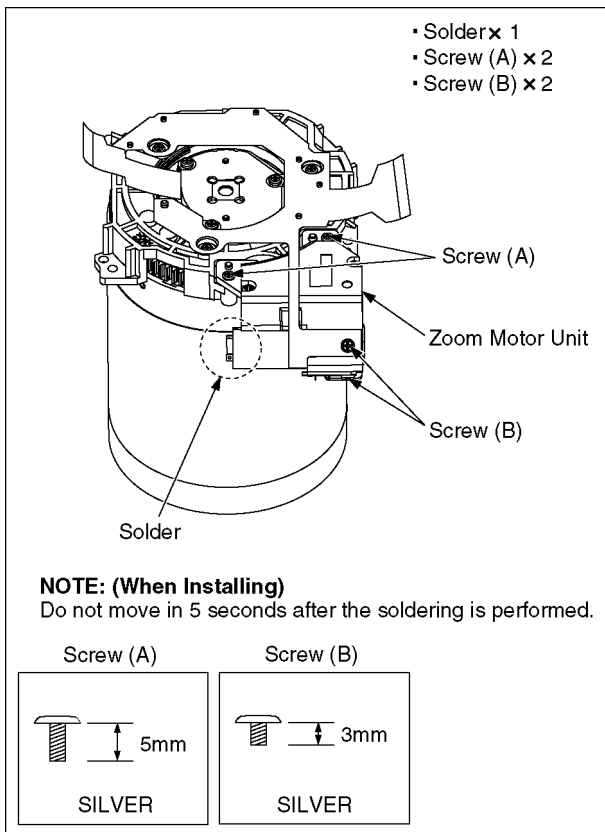
- Install the "Top operation unit" first, then install the "Flash unit & EVF unit".
- The Screw is tightened enough.
- Assembling conditions are fine. (No distortion, no illegal-space.)
- No dust and/or dirt on every Lens surfaces.
- LCD image is fine. (No dust and dirt on it, and no gradient images.)

8.4. Disassembly/Assembly Procedure for the Lens

NOTE: When Disassembling and Assembling for the Lens

1. Recommended clean level of repairing lens unit for this model is less than class 10,000. (Federal Standard 209D)
To keep maintaining the dust proof environment, it is recommended dealing with Clean box (Refer to "7.2. Clean Box" which is found in section "7. Service Fixture & Tools" of this manual.)
2. To minimize the possibility of the CCD being dirt, perform disassemble and/or assemble under the condition of the CCD is being mounted.
Disassembling procedures for the CCD unit, refer to item 8.5.
3. Take care that the dust and dirt are not entered into the lens.
In case of the dust is putted on the lens, blow off them by airbrush.
4. Do not touch the surface of lens.
5. Use lens cleaning KIT (BK)(VFK1900BK).
6. Apply the grease (RFKZ0472) to the point where is shown to "Grease apply" in the figure.
When the grease is applied, use a toothpick and apply thinly.

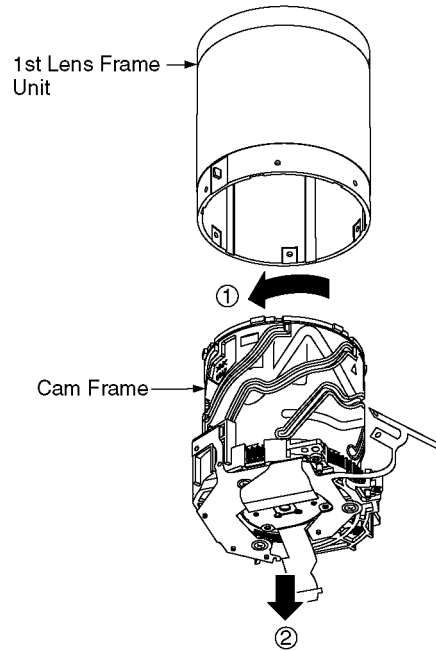
8.4.1. Removal of the Zoom Motor Unit



8.4.2. Removal of the 1st Lens Frame Unit

IMPORTANT NOTE:

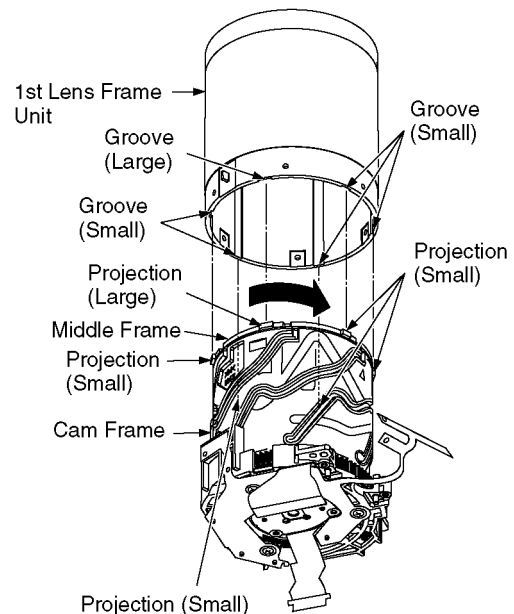
Keep face up the lens frame unit when removing/installing. Otherwise, the 2nd Lens Frame Unit may be dropped and damaged.



NOTE: (When Removing)

Remove the 1st Lens Frame Unit by rotating the Cam Frame in arrow directions.
Removal order: ①→②.

When the Cam Frame is hard to rotate, use the tweezers and rotate round gear of the Cam Frame.



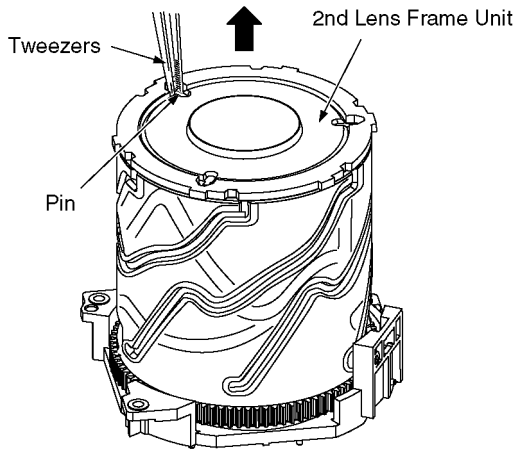
NOTE: (When Installing)

Align the groove of 1st Lens Frame Unit and the projection of Middle Frame, and then turn the Cam Frame counterclockwise fully to make retract position.

8.4.3. Removal of the 2nd Lens Frame Unit

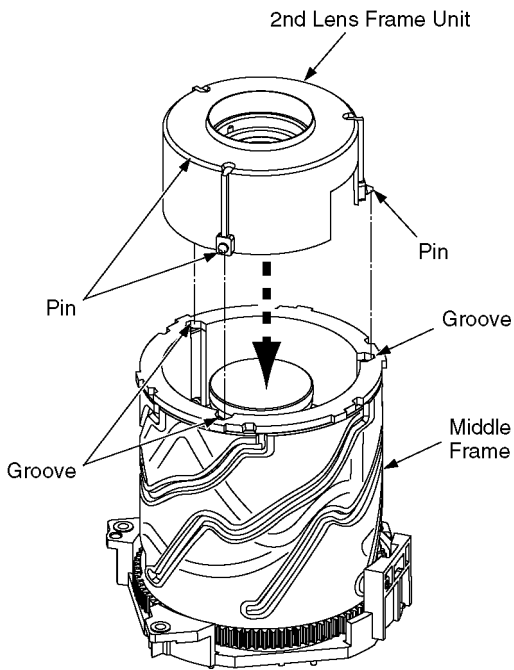
NOTE: (When Removing)

Anchor the pin of 2nd Lens Frame Unit with tweezers, then remove it in the direction of an arrow.



NOTE: (When Installing)

Align the pin of 2nd Lens Frame Unit and the groove of Middle Frame, and then install.

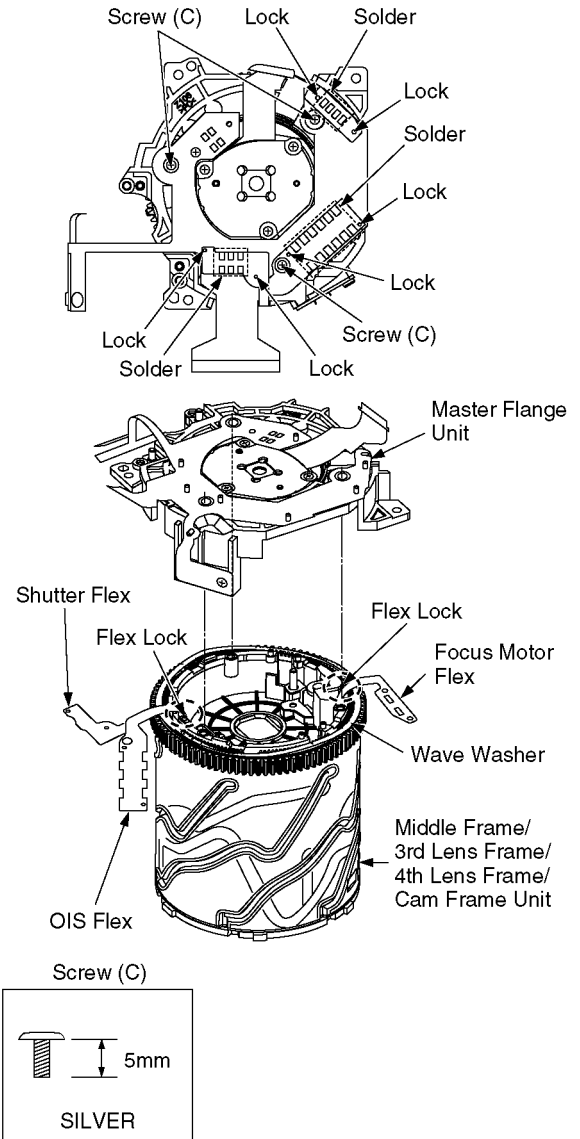


8.4.4. Removal of the Master Flange Unit

- Screw (C) × 3
- Lock × 6
- Solder × 3

NOTE: (When Removing)

When remove the Master Flange Unit, take care not to damage the OIS, Shutter and Focus Motor flex.



NOTE: (When Installing)

1. Attach the Wave Washer.
2. Fix the OIS, Shutter and Focus Motor Flex on the lock.
3. Tighten 3 screws (C).
4. Fix 6 locks on Master Flange Unit.
5. Soldered.

- ※ Do not move in 5 seconds after the soldering is performed.
- ※ Take care not to cut the OIS, Shutter and Focus Motor Flex.

8.4.5. Removal of the Cam Frame

NOTE: (When Removing)
When remove the Cam Frame, take care not to damage the OIS, Shutter and Focus Motor Flex.

NOTE: (When Installing)
Align phase mark of middle frame unit and phase mark of Cam Frame, and then install.

8.4.6. Removal of the Focus Motor Unit

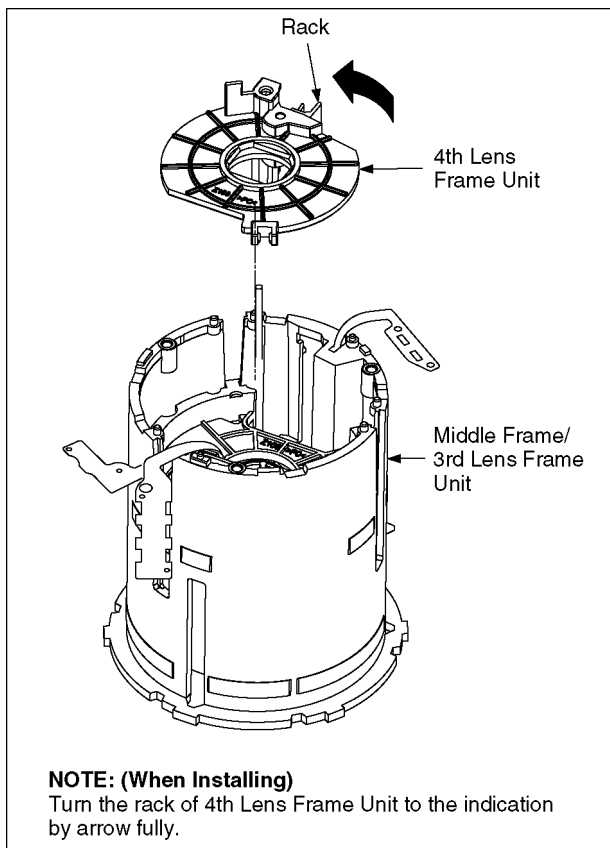
• Screw (D) × 2
• Lock × 3

NOTE: (When Removing)
When remove the Focus Motor, take care not to damage the Focus Motor Flex.

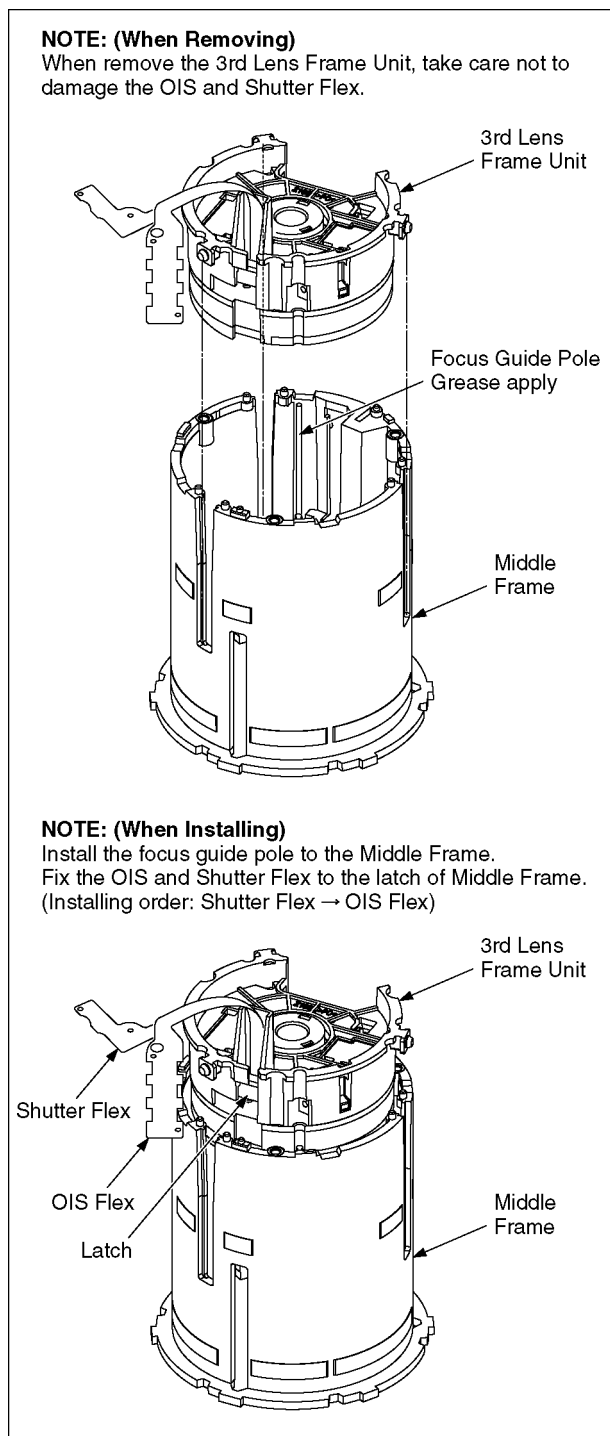
NOTE: (When Installing)

1. Insert the Focus Motor Flex to the cut of Middle Frame, and then install Focus Motor Unit.
2. Confirm the rack of 4th Lens Frame Unit is engaged with screw shaft of Focus Motor.

8.4.7. Removal of the 4th Lens Frame Unit

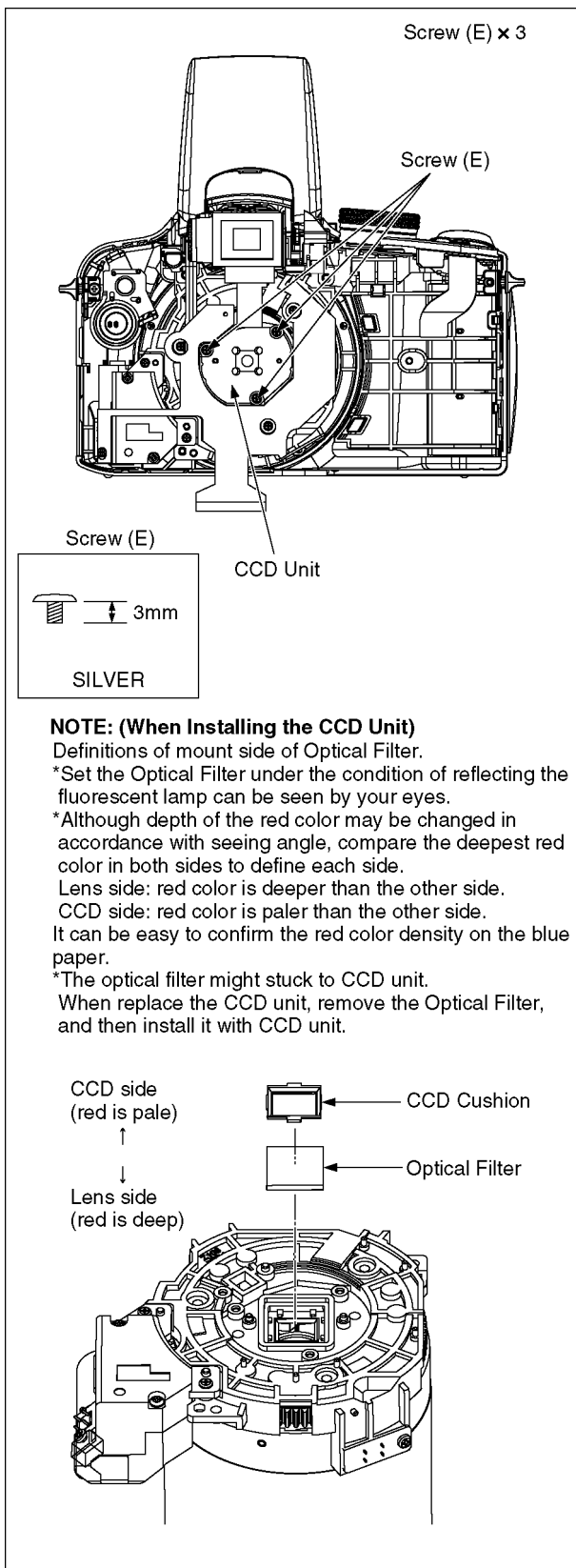


8.4.8. Removal of the 3rd Lens Frame Unit



8.5. Removal of the CCD Unit

To prevent the CCD unit from catching the dust and dirt, do not remove the CCD unit except for replacing.



9 Measurements and Adjustments

9.1. Matrix Chart for Replaced Part and Necessary Adjustment

The relation between Replaced part and Necessary Adjustment is shown in the following table.

When concerned part is replaced, be sure to achieve the necessary adjustment(s).

As for Adjustment condition/procedure, consult the "Adjustment Manual" which is available in Adjustment software.

The Adjustment software is available at "TSN Web-site", therefore, access to "TSN Web-site" at "Support Information from NWBG/VDBG-PAVC".

NOTE:

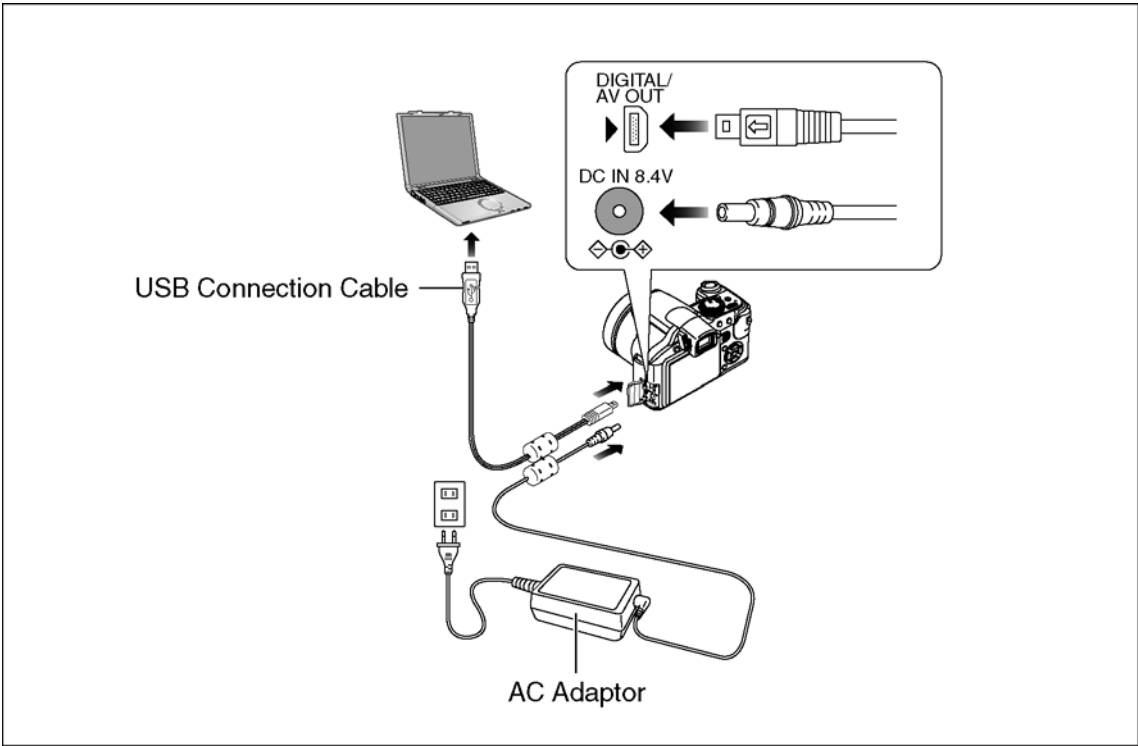
After adjustments have been terminated, make sure to achieve "INITIAL SETTINGS".

Adjustment Item		Replaced Part					
		Main P.C.B.	VENUS (IC6001)	Flash-ROM (IC6002)	Lens Part (Excluding CCD)	CCD Unit	LCD/EVF
Camera Section	OIS hall element adjustment (OIS)	○	○	○	○	-	-
	Back focus adjustment (BF)	○	○	○	○	○*1	-
	Shutter adjustment (SHT)	○	○	○	○	○	-
	ISO sensitivity adjustment (ISO)	○	○	○	○	○	-
	AWB adjustment High brightness coloration inspection (WBL)	○	○	○	○	○	-
	Linearity adjustment (LIN)	○	○	○	○	○	-
	CCD white scratch compensation (WKL)	○	○	○	-	○*1	-
	CCD black scratch compensation (BKL)	○	○	○	-	○*1	-
	IRIS adjustment (IRS)	○	○	○	○	○	-
	Venus zoom inspection (PZM)	○	○	○	-	-	-
	Monitor linearity inspection (MLN)	○	○	○	○	○	-

*1 This adjustment is necessary, not only replacing CCD unit but also removing it from the lens unit.

NOTE:

*There is no LCD and EVF adjustment in this model.



10 Maintenance

10.1. Cleaning Lens, Viewfinder and LCD Panel

Do not touch the surface of lens, Viewfinder and LCD Panel with your hand.

When cleaning the lens, use air-Blower to blow off the dust.

When cleaning the LCD Panel, dampen the lens cleaning paper with lens cleaner, and the gently wipe the their surface.

Note:

The Lens Cleaning KIT ; VFK1900BK(Only supplied as 10 set/Box) is available as Service Aid.

Service Manual

Diagrams and Replacement Parts List

Digital Camera

Model No.

DMC-FZ28P	DMC-FZ28EG	DMC-FZ28GT
DMC-FZ28PC	DMC-FZ28E	DMC-FZ28GJ
DMC-FZ28PL	DMC-FZ28GC	DMC-FZ28SG
DMC-FZ28EB	DMC-FZ28GD	
DMC-FZ28EE	DMC-FZ28GK	
DMC-FZ28EF	DMC-FZ28GN	

Vol. 1

Colour

(S).....Silver Type (only P/PC/EB/EE/EF/EG/E/GC/SG)

(K).....Black Type

Table of contents

S1. About Indication of The Schematic Diagram S-1
 S1.1. Important Safety Notice..... S-1

S2. Block Diagram..... S-2
 S2.1. Overall Block Diagram S-2

S3. Schematic Diagram..... S-3
 S3.1. Interconnection Diagram S-3
 S3.2. AF LED/Mic Schematic Diagram..... S-4
 S3.3. CCD Flex Schematic Diagram S-5
 S3.4. Lens Flex Schematic Diagram S-6

S4. Print Circuit Board S-7
 S4.1. AF LED/Mic P.C.B. S-7
 S4.2. CCD Flex P.C.B..... S-8
 S4.3. Lens Flex P.C.B..... S-9

S5. Replacement Parts List..... S-11

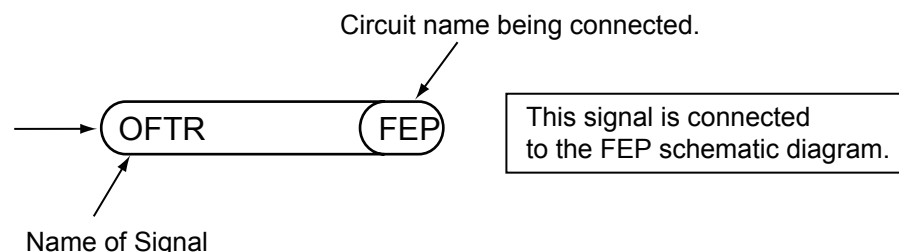
S6. Exploded View S-15
 S6.1. Frame and Casing Section (1) S-15
 S6.2. Frame and Casing Section (2) S-16
 S6.3. Packing Parts and Accessories Section..... S-17

S1. About Indication of The Schematic Diagram

S1.1. Important Safety Notice

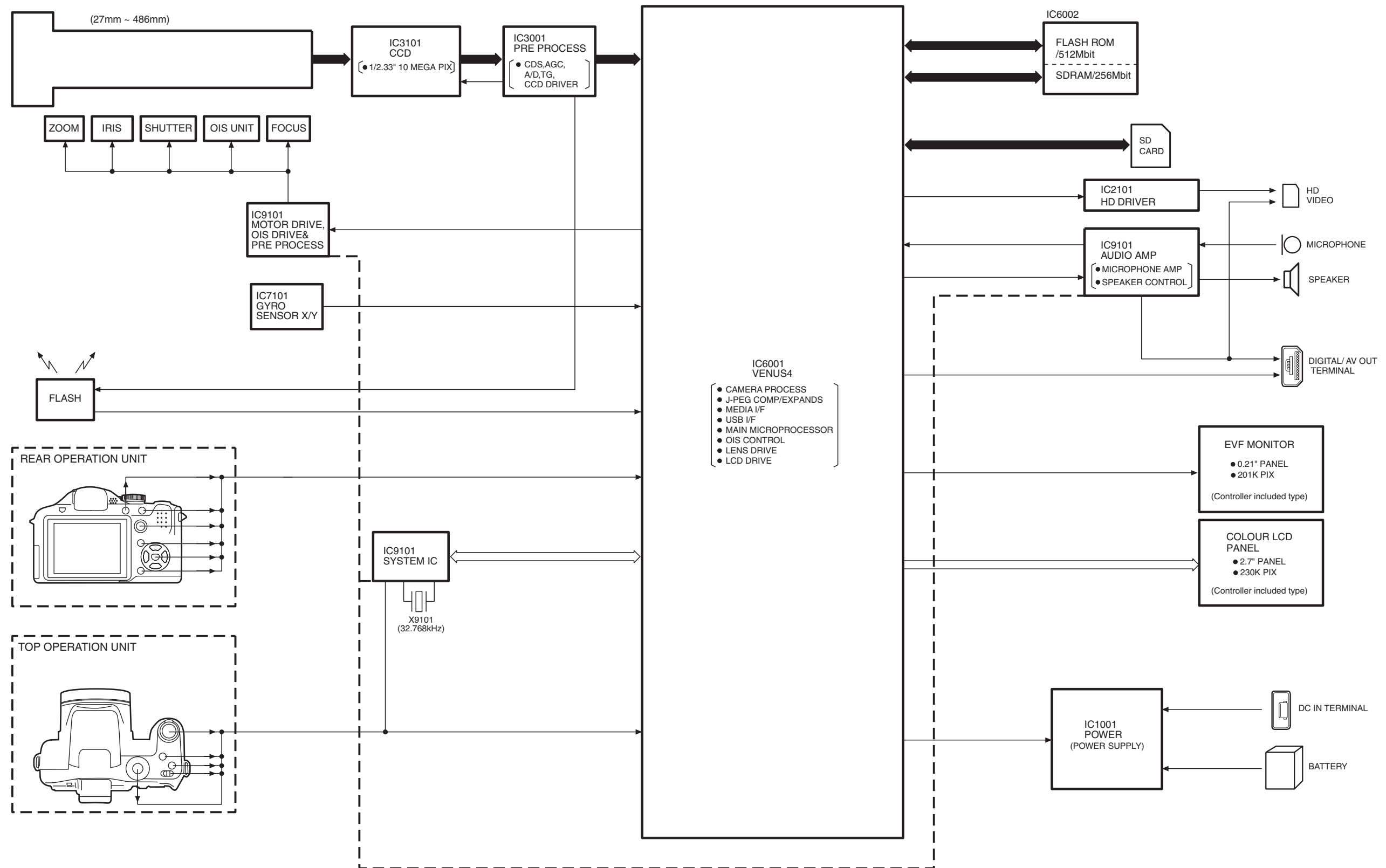
COMPONENTS IDENTIFIED WITH THE MARK \triangle HAVE THE SPECIAL CHARACTERISTICS FOR SAFETY. WHEN REPLACING ANY OF THESE COMPONENTS USE ONLY THE SAME TYPE.

1. Although reference number of the parts is indicated on the P.C.B. drawing and/or schematic diagrams, it is NOT mounted on the P.C.B. when it is displayed with "\$" mark.
2. It is only the "Test Round" and no terminal (Pin) is available on the P.C.B. when the TP (Test Point) indicated as "●" mark.
3. The voltage being indicated on the schematic diagram is measured in "Standard-Playback" mode when there is no specify mode is mentioned.
4. Although the voltage and waveform available on here is measured with standard frame, it may be differ from actual measurement due to modification of circuit and so on.
5. The voltage being indicated here may be include observational-error (deviation) due to internal-resistance and/or reactance of equipment. Therefore, handle the value indicated on here as reference.
6. Use the parts number indicated on the Replacement Parts List .
7. Indication on Schematic diagrams:



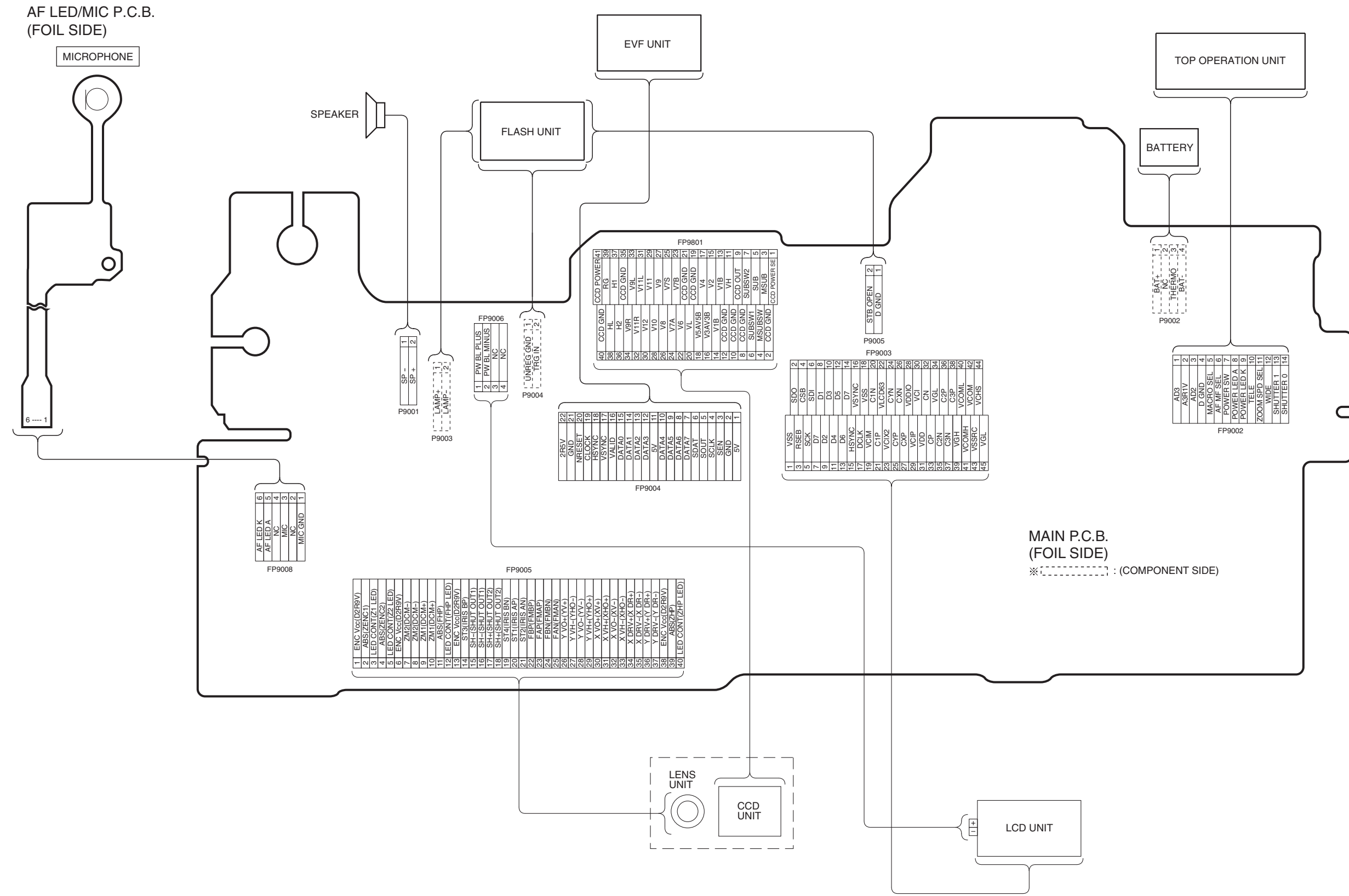
S2. Block Diagram

S2.1. Overall Block Diagram

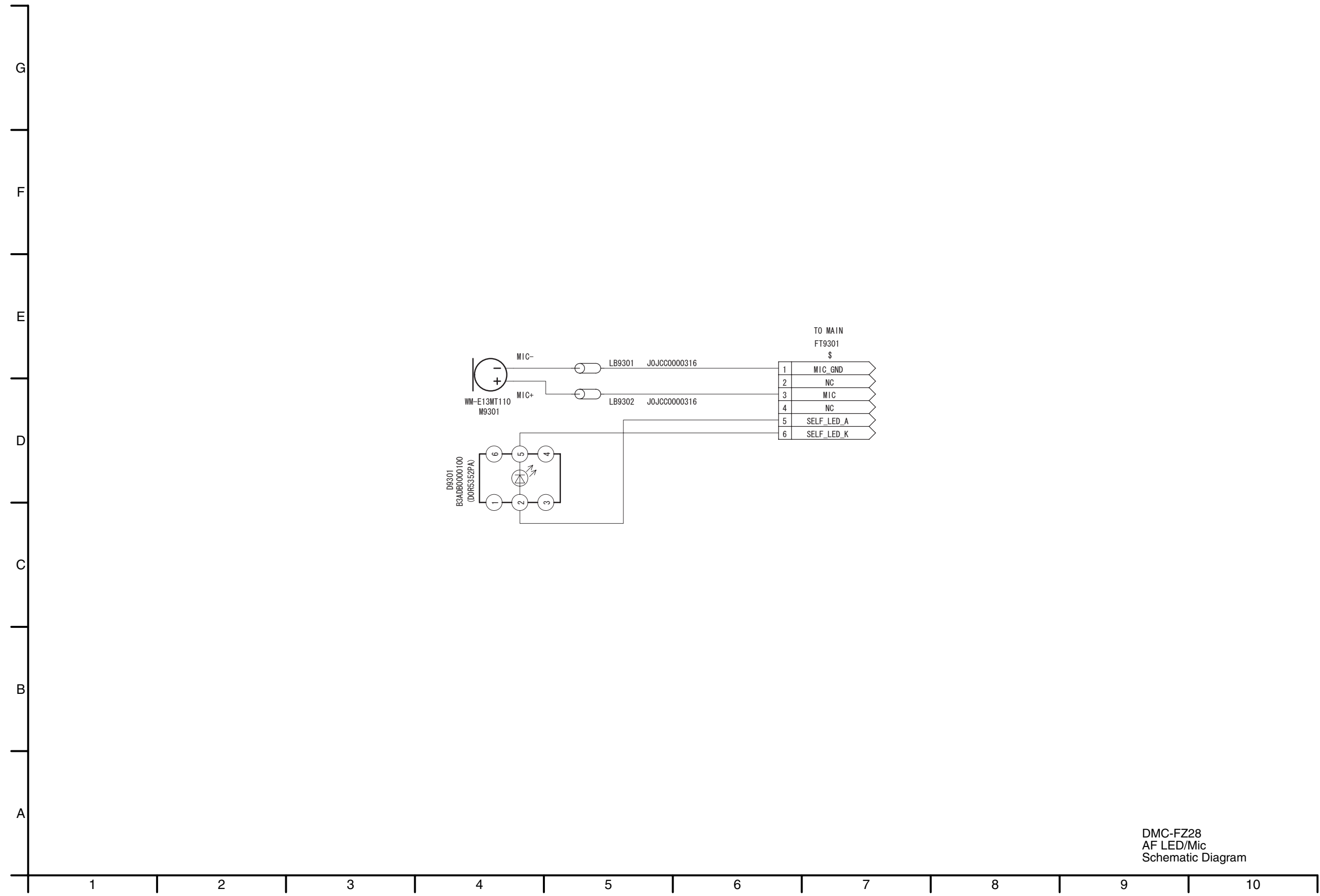


S3. Schematic Diagram

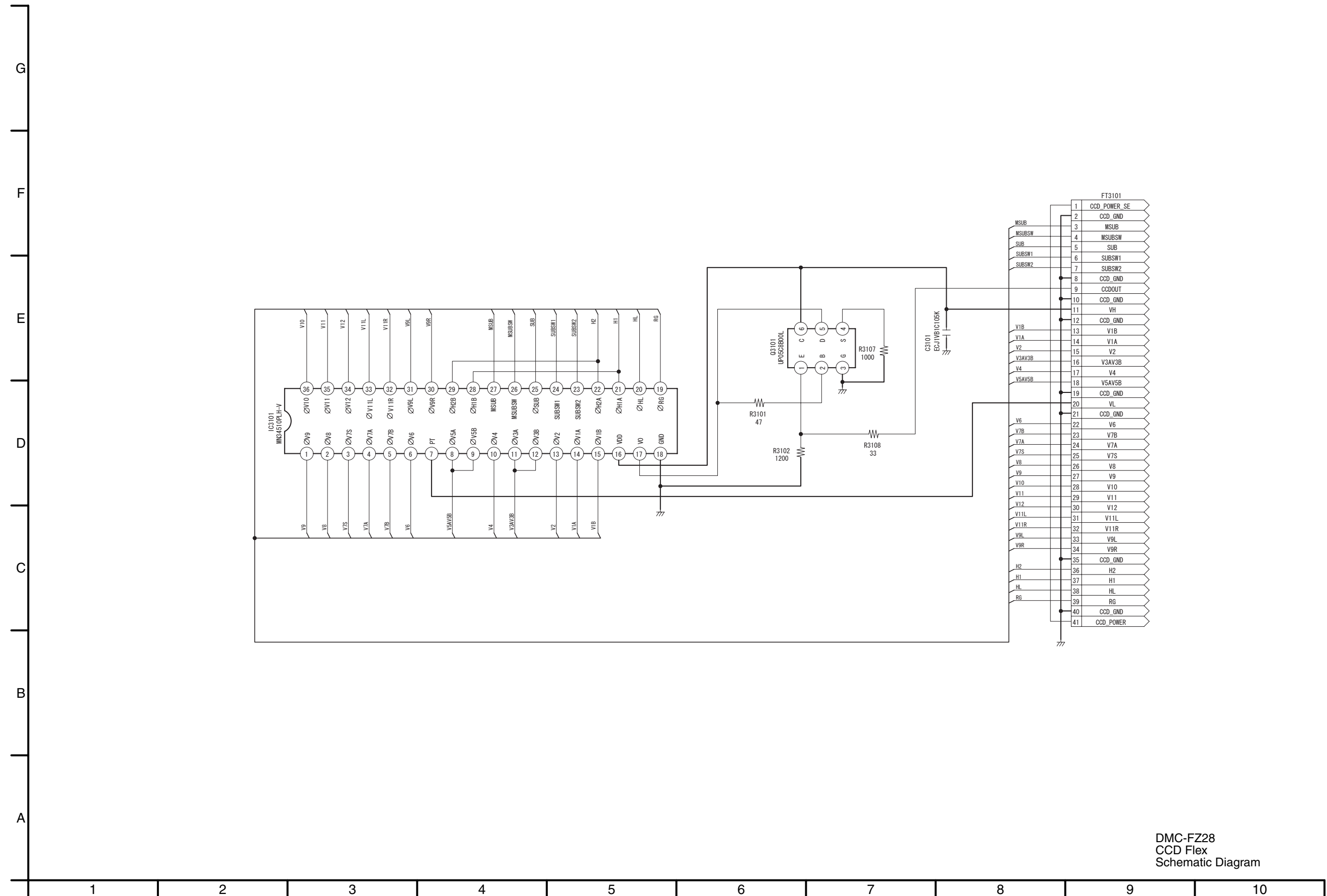
S3.1. Interconnection Diagram



S3.2. AF LED/Mic Schematic Diagram

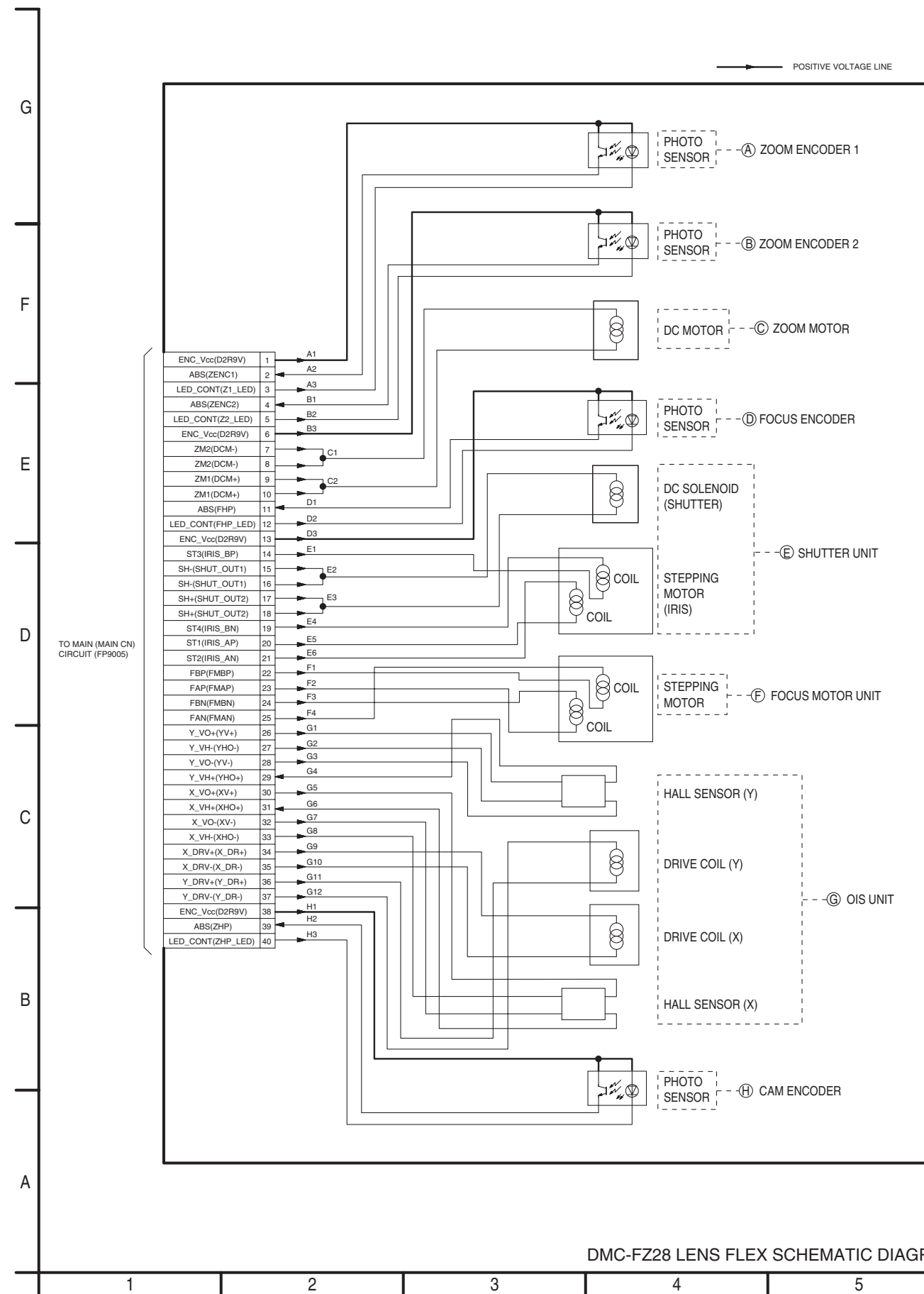


S3.3. CCD Flex Schematic Diagram



DMC-FZ28
CCD Flex
Schematic Diagram

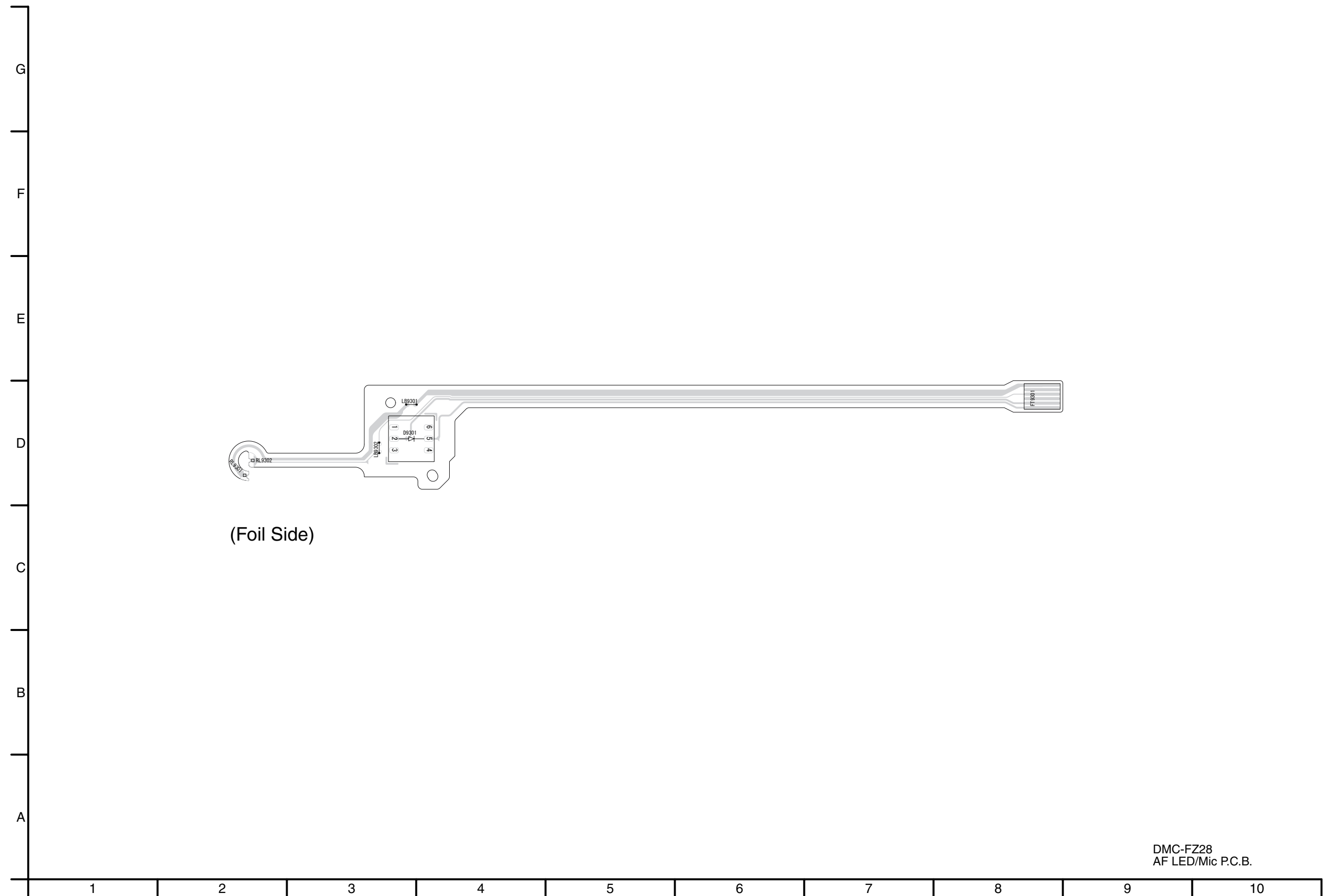
S3.4. Lens Flex Schematic Diagram



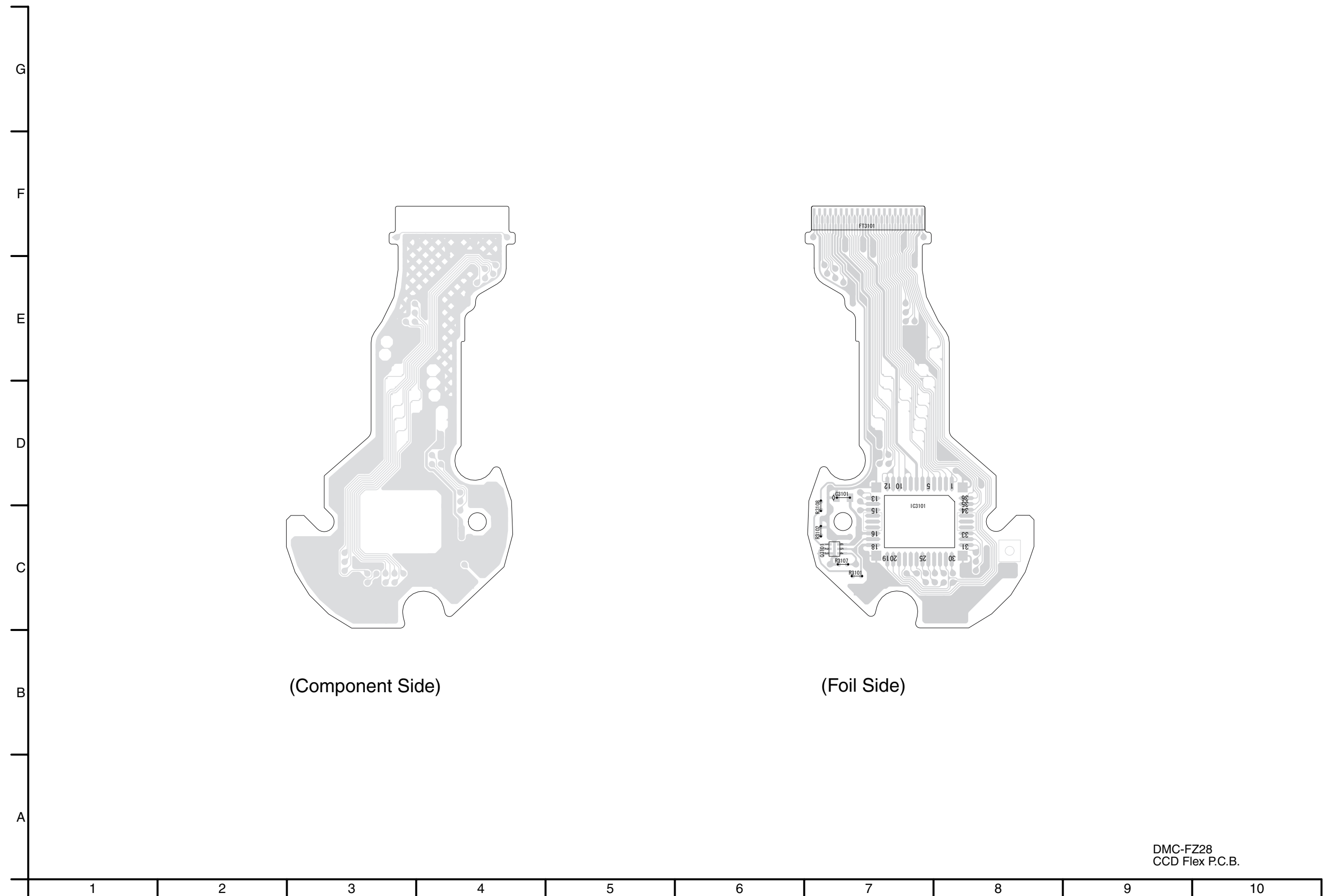
DMC-FZ28 LENS FLEX SCHEMATIC DIAGRAM

S4. Print Circuit Board

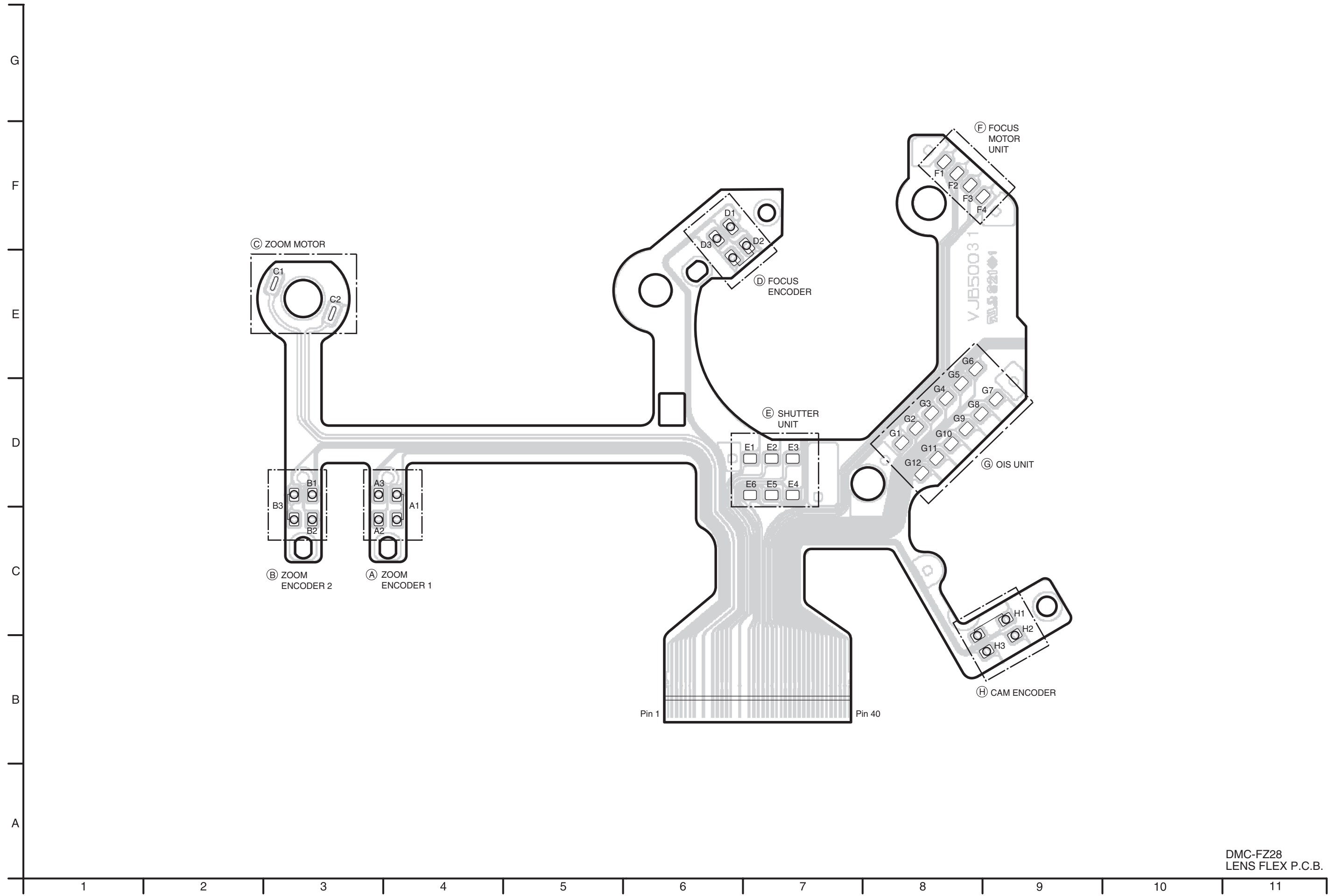
S4.1. AF LED/Mic P.C.B.



S4.2. CCD Flex P.C.B.



S4.3. Lens Flex P.C.B.



DMC-FZ28
LENS FLEX P.C.B.

S5. Replacement Parts List

- Note: 1.* Be sure to make your orders of replacement parts according to this list.
2. IMPORTANT SAFETY NOTICE
Components identified with the mark \triangle have the special characteristics for safety.
When replacing any of these components, use only the same type.
3. Unless otherwise specified,
All resistors are in OHMS, K=1,000 OHMS. All capacitors are in MICRO-FARADS (uf), P=uuF.
4. The marking (RTL) indicates the retention time is limited for this item. After the discontinuation of this assembly in production, it will no longer be available.

E.S.D. standards for Electrostatically Sensitive Devices, refer to "PREVENTION OF ELECTROSTATIC DISCHARGE (ESD) TO ELECTROSTATICALLY SENSITIVE (ES) DEVICES" section.

Definition of Parts supplier:

1. Parts marked with [MBI] in the remarks column are supplied from "Matsushita Battery Industrial Co., Ltd."
2. Parts marked with [PAVC-CSG] in the remarks column are supplied from PAVC COMPANY CS Group (PAVC-CSG).
Others are supplied from "Panasonic Shikoku Electronics Co., Ltd." (PSEC-SAIJO).

DMC-FZ28E/EB/EE/EF/EG/GC/GD/GJ/GK/GN/GT/P/PC/PL/SG

Ref.No.	Part No.	Part Name & Description	Pcs	Remarks
2	VDW1625	LENS RING FRONT	1	(-K)
2	VDW1624	LENS RING FRONT	1	(-S)
3	VGUC75	FLASH LOCK LEVER KNOB	1	(-K)
3	VGUC74	FLASH LOCK LEVER KNOB	1	(-S)
4	VYK2R26	FRONT CASE 1(U)	1	(-K)
4	VYK2R25	FRONT CASE 1(U)	1	(-S)
4-1	VGQ9469	GRIP PIECE FRONT	1	(-K) (PAVC-CSG)
4-1	VGQ9468	GRIP PIECE FRONT	1	(-S) (PAVC-CSG)
4-2	VMS7523	STRAP HOLDER	1	(PAVC-CSG)
8	VYK2S86	FLASH (1)U	1	(-K)
8	VYK2S83	FLASH (1)U	1	(-S)
8-1	VKM7553	FLASH CASE TOP	1	(-K)
8-1	VKM7213	FLASH CASE TOP	1	(-S)
8-2	VYQ3749	FLASH SW(U)	1	
10	L5EDDXE00004	EVF UNIT	1	
53	VXP2968	2ND.LENS FRAME UNIT	1	(PAVC-CSG)
54	VDW1609	MIDDLE FRAME	1	(PAVC-CSG)
55	L6HA68ZD0001	FOCUS MOTOR UNIT	1	(PAVC-CSG)
56	VXP2944	3RD.LENS FRAME UNIT	1	(PAVC-CSG)
57	VXP3057	4TH.LENS FRAME UNIT	1	(PAVC-CSG)
58	VDW1610	CAM FRAME	1	(PAVC-CSG)
59	VDW1607	MASTER FLANGE	1	(PAVC-CSG)
60	L6DA8BGD0001	ZOOM MOTOR UNIT	1	(PAVC-CSG)
61	VEK0M96	LENS FLEX.UNIT	1	(PAVC-CSG)
61-1	B3NAA0000074	PHOTO SENSOR	1	(PAVC-CSG)
61-2	B3NAA0000132	PHOTO SENSOR	1	(PAVC-CSG)
61-3	B3NAA0000132	PHOTO SENSOR	1	(PAVC-CSG)
61-4	B3NAA0000132	PHOTO SENSOR	1	(PAVC-CSG)
62	VDL2073	OPTICAL FILTER	1	(PAVC-CSG)
63	VMX3650	CCD CUSHION	1	(PAVC-CSG)
64	VEK0M50	CCD UNIT	1	(PAVC-CSG) E.S.D.
65	VXP2945	1ST.LENS FRAME UNIT	1	(-K) (PAVC-CSG)
65	VXP2941	1ST.LENS FRAME UNIT	1	(-S) (PAVC-CSG)
66	VMC2028	WASHER	1	(PAVC-CSG)
71	VMS7833	FOCUS GUIDE POLE	1	(PAVC-CSG)
72	VXW0958	LENS UNIT(W/O CCD)	1	(-K) (PAVC-CSG)
72	VXW0944	LENS UNIT(W/O CCD)	1	(-S) (PAVC-CSG)
B1	VHD1684	SCREW	1	(-K)
B1	VHD1680	SCREW	1	(-S)
B9	VHD1870	SCREW	1	
B10	VHD1839	SCREW	1	
B13	XQN16+B.J4FN	SCREW	1	(PAVC-CSG)
B14	XQN16+B.J8FN	SCREW	1	
B19	XQN16+B.J4FN	SCREW	1	(PAVC-CSG)
B20	VHD1684	SCREW	1	
B23	VHD1870	SCREW	1	(-K)
B23	VHD1940	SCREW	1	(-S)
B24	VHD1870	SCREW	1	
B25	VHD1680	SCREW	1	
B26	VHD1680	SCREW	1	
B27	VHD1680	SCREW	1	
B50	XQN14+C.J3FN	SCREW	1	(PAVC-CSG)
B51	XQN14+C.J3FN	SCREW	1	(PAVC-CSG)
B52	XQN14+C.J3FN	SCREW	1	(PAVC-CSG)
B53	XQN14+C.J3FN	SCREW	1	(PAVC-CSG)
B54	XQN14+C.J3FN	SCREW	1	(PAVC-CSG)
B55	XQN14+C.J3FN	SCREW	1	(PAVC-CSG)
B56	XQN14+C.J3FN	SCREW	1	(PAVC-CSG)
B57	XQN16+C.J5FN	SCREW	1	(PAVC-CSG)
B58	XQN16+C.J5FN	SCREW	1	(PAVC-CSG)
B59	XQN16+C.J5FN	SCREW	1	(PAVC-CSG)
B60	XQN16+C.J5FN	SCREW	1	(PAVC-CSG)
B61	XQN16+C.J5FN	SCREW	1	(PAVC-CSG)
B62	XQN16+C.J5FN	SCREW	1	(PAVC-CSG)
B63	XQN16+C.J5FN	SCREW	1	(PAVC-CSG)

Ref.No.	Part No.	Part Name & Description	Pcs	Remarks
1	K0RB02100004	TOP OPERATION UNIT	1	(-K)
1	K0RB02100003	TOP OPERATION UNIT	1	(-S)
11	K1Z200001463	BATTERY CATCHER	1	
13	VEP56068A	MAIN P.C.B.	1	(RTL) E.S.D.
14	VGQ8573	JOY COVER	1	
15	VGQ9541	CONDENSER COVER (A)	1	
16	VGQ9543	AF LED HOLDER	1	
17	VGU9911	JOY STICK KNOB	1	
18	VYK2R34	BATTERY FRAME(U)	1	(-K)
18	VYK2R33	BATTERY FRAME(U)	1	(-S)
18-1	VMB4039	BATTERY SPRING	1	(PAVC-CSG)
19	VGQ9542	CONDENSER COVER (B)	1	
20	VYQ4398	JACK DOOR (U)	1	(-K)
20	VYQ4084	JACK DOOR (U)	1	(-S)
21	VEP59048A	AF/LED MIC P.C.B.	1	(RTL) E.S.D.
22	VMT1837	MIC DAMPER	1	
24	L0AA01A00034	SPEAKER	1	
26	VMP9120	SP FIX PLATE	1	
32	VYQ4420	LCD MODULE (U)	1	
35	VYK2W78	REAR CASE(1)U	1	(-K)
35	VYK2W77	REAR CASE(1)U	1	(-S)
35-3	VMS7523	STRAP HOLDER	1	(PAVC-CSG)
38	VYQ4401	HD TERMINAL DOOR U	1	(-K)
38	VYQ4400	HD TERMINAL DOOR U	1	(-S)
B2	VHD1684	SCREW	1	(-K)
B2	VHD1680	SCREW	1	(-S)
B3	VHD1684	SCREW	1	(-K)
B3	VHD1680	SCREW	1	(-S)
B11	VHD1680	SCREW	1	
B15	XQN16+B.J8FN	SCREW	1	
B16	XQN16+B.J8FN	SCREW	1	
B17	XQN16+B.J4FN	SCREW	1	
B18	XQN16+B.J4FN	SCREW	1	
B21	VHD1870	SCREW	1	(-K)
B21	VHD1940	SCREW	1	(-S)
B22	VHD1870	SCREW	1	(-K)
B22	VHD1940	SCREW	1	(-S)
B28	XQN16+B.J4FN	SCREW	1	(PAVC-CSG)
B29	XQN16+B.J4FN	SCREW	1	(PAVC-CSG)
B30	XQN16+B.J4FN	SCREW	1	
B31	XQN16+B.J4FN	SCREW	1	

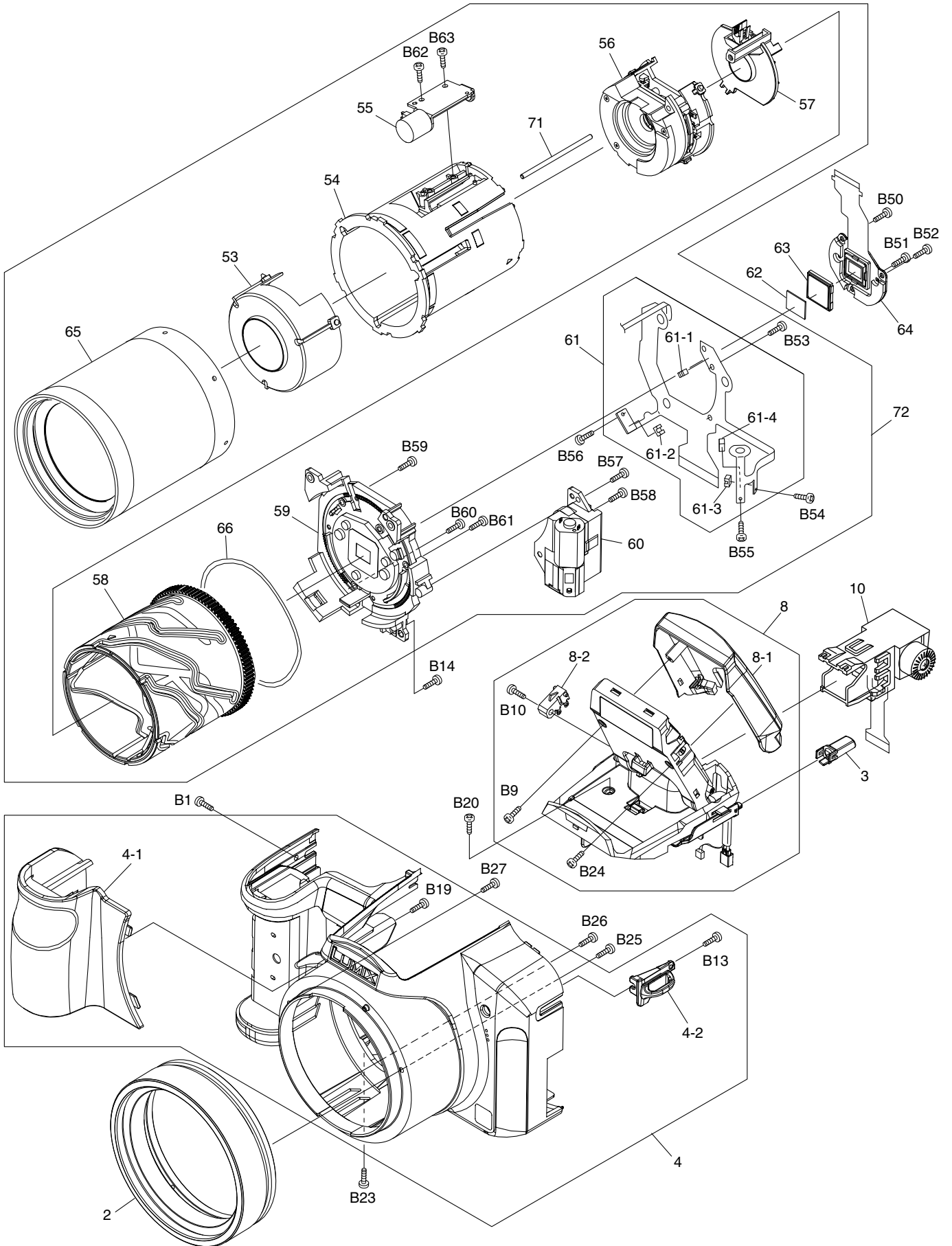
DMC-FZ28E/EB/EE/EF/EG/GC/GD/GJ/GK/GN/GT/P/PC/PL/SG

Ref.No.	Part No.	Part Name & Description	Pcs	Remarks
△ 100	-----	BATTERY PACK	1	
△ 101	DE-A44AA	BATTERY CHARGER	1	E,EB,EF,EG,GN
△ 101	DE-A44BA	BATTERY CHARGER	1	EE,GC,GD,GJ,GK,SG
△ 101	DE-A44CA	BATTERY CHARGER	1	GT
△ 101	DE-A43BA	BATTERY CHARGER	1	P,PC,PL
102	K1HA08CD0019	USB CABLE	1	(PAVC-CSG)
103	K1HA08CD0020	AV CABLE	1	(PAVC-CSG)
105	VFC4269	SHOULDER BELT	1	
106	VFF0423-S	CD-ROM	1	(EXCEPT (GK))
				(PAVC-CSG) See "Notes"
106	VFF0424-S	CD-ROM	1	(GK)
				(PAVC-CSG) See "Notes"
107	VFF0433-J	CD-ROM(O/I)	1	E,EG,GC,PL,SG
108	VPF1294	POLY BAG	1	(PAVC-CSG)
113	VYK2U93	LENS CAP U	1	
116	VYQ4122	STAR HOOD (U)	1	(-K) (PAVC-CSG)
116	VYQ4123	STAR HOOD (U)	1	(-S) (PAVC-CSG)
117	VYQ4124	HOOD HOLDER (U)	1	(PAVC-CSG)
118	VPF1166	CAMERA BAG	1	
120	VPK3622	PACKING CASE	1	(-K) E,EB,EE,EF,EG,GC,GD, GJ,GN,GT,PL,SG
120	VPK3619	PACKING CASE	1	(-S) E,EB,EE,EF,EG,GC,SG
120	VPK3623	PACKING CASE	1	(-K) GK
120	VPK3621	PACKING CASE	1	(-K) P,PC
120	VPK3618	PACKING CASE	1	(-S) P,PC
123	VPN6735	CUSHION	1	
△ 124	K2CQ2CA00006	AC CABLE	1	E,EE,EF,EG,GC,SG
△ 124	K2CR2DA00004	AC CABLE	1	E,EE,EF,EG,GC
△ 126	K2CT3CA00004	AC CABLE	1	GC,SG,EB
△ 127	K2CR2CA00003	AC CABLE	1	GD
△ 128	K2CP2YY00001	AC CABLE	1	GJ
△ 129	K2CA2CA00020	AC CABLE	1	GK
△ 130	K2CJ2DA00008	AC CABLE	1	GN
△ 131	K2CA2CA00027	AC CABLE	1	GT
132	VQT1S78	O/I SUPPLIED SOFTWARE (FINNISH/SWEDISH/DANISH/ POLISH/CZECH/ HUNGARIAN)	1	E (PAVC-CSG)
132	VQT1S80	O/I SUPPLIED SOFTWARE (ENGLISH)	1	EB,GN (PAVC-CSG)
132	VQT1S81	O/I SUPPLIED SOFTWARE (RUSSIAN/UKRAINIAN)	1	EE (PAVC-CSG)
132	VQT1S79	O/I SUPPLIED SOFTWARE (FRENCH)	1	EF (PAVC-CSG)
132	VQT1S77	O/I SUPPLIED SOFTWARE (GERMAN/FRENCH/ITALIAN/ DUTCH/SPANISH/ PORTUGUESE)	1	EG (PAVC-CSG)
132	VQT1S82	O/I SUPPLIED SOFTWARE (ENGLISH/ CHINESE(TRADITIONAL)/ ARABIC/PERSIAN)	1	GC,SG (PAVC-CSG)
132	VQT1S86	O/I SUPPLIED SOFTWARE (KOREAN)	1	GD (PAVC-CSG)
132	VQT1S83	O/I SUPPLIED SOFTWARE (THAI)	1	GJ (PAVC-CSG)
132	VQT1S85	O/I SUPPLIED SOFTWARE (CHINESE(SIMPLIFIED))	1	GK (PAVC-CSG)
132	VQT1S84	O/I SUPPLIED SOFTWARE (CHINESE(TRADITIONAL))	1	GT (PAVC-CSG)
132	VQT1S75	O/I SUPPLIED SOFTWARE (ENGLISH/CANADIAN FRENCH)	1	P,PC (PAVC-CSG)
132	VQT1S76	O/I SUPPLIED SOFTWARE (ENGLISH/SPANISH/ PORTUGUESE)	1	PL (PAVC-CSG)
△ 133	VQT1S48	OPERATING INSTRUCTIONS (ENGLISH)	1	EB (PAVC-CSG)
△ 133	VQT1S49	OPERATING INSTRUCTIONS (RUSSIAN)	1	EE (PAVC-CSG)
△ 133	VQT1S50	OPERATING INSTRUCTIONS (UKRAINIAN)	1	EE (PAVC-CSG)
△ 133	VQT1S47	OPERATING INSTRUCTIONS (FRENCH)	1	EF (PAVC-CSG)
△ 133	VQT1S57	OPERATING INSTRUCTIONS (KOREAN)	1	GD (PAVC-CSG)

Ref.No.	Part No.	Part Name & Description	Pcs	Remarks
△ 133	VQT1S53	OPERATING INSTRUCTIONS (THAI)	1	GJ (PAVC-CSG)
△ 133	VQT1S55	OPERATING INSTRUCTIONS (CHINESE(SIMPLIFIED))	1	GK (PAVC-CSG)
△ 133	VQT1S56	OPERATING INSTRUCTIONS (ENGLISH)	1	GN (PAVC-CSG)
△ 133	VQT1S54	OPERATING INSTRUCTIONS (CHINESE (TRADITIONAL))	1	GT (PAVC-CSG)
△ 133	VQT1S36	OPERATING INSTRUCTIONS (ENGLISH)	1	P,PC (PAVC-CSG)
△ 133	VQT1S37	OPERATING INSTRUCTIONS (SPANISH)	1	P (PAVC-CSG)
△ 133	VQT1S38	OPERATING INSTRUCTIONS (CANADIAN FRENCH)	1	PC (PAVC-CSG)
△ 134	VQL1G34	OPERATING LABEL (CHINESE)	1	GT-K (PAVC-CSG)
△ 134	VQL1L48	OPERATING LABEL (C.FRENCH)	1	PC-K (PAVC-CSG)
△ 134	VQL1L48	OPERATING LABEL (C.FRENCH)	1	PC-S (PAVC-CSG)
△ 135	VQT1S44	BASIC O/I (SWEDISH/DANISH)	1	E (PAVC-CSG)
△ 135	VQT1S45	BASIC O/I (POLISH/CZECH)	1	E (PAVC-CSG)
△ 135	VQT1S46	BASIC O/I (HUNGARIAN/FINNISH)	1	E (PAVC-CSG)
△ 135	VQT1S41	BASIC O/I (GERMAN/FRENCH)	1	EG (PAVC-CSG)
△ 135	VQT1S42	BASIC O/I (ITALIAN/DUTCH)	1	EG (PAVC-CSG)
△ 135	VQT1S43	BASIC O/I (SPANISH/PORTUGUESE)	1	EG (PAVC-CSG)
△ 135	VQT1S51	BASIC O/I (ENGLISH/ CHINESE (TRADITIONAL))	1	GC,SG (PAVC-CSG)
△ 135	VQT1S52	BASIC O/I (ARABIC/PERSIAN)	1	GC (PAVC-CSG)
△ 135	VQT1S39	BASIC O/I (ENGLISH/SPANISH)	1	PL (PAVC-CSG)
△ 135	VQT1S40	BASIC O/I (PORTUGUESE)	1	PL (PAVC-CSG)

S6. Exploded View

S6.1. Frame and Casing Section (1)



S6.2. Frame and Casing Section (2)

